

Universal Control Unit UC-2A

UC-2A 通用润滑系统控制器

User's Manual

用户操作指导手册

Suzhou Leetern Industry Control Department

March. 2011

Universal Control Unit UC-2 is designed for controlling and monitoring of centralized Lubrication system. It is suitable for injection lubrication control for machinery and equipment like conveyor belt and escalator etc. UC-2A stores control modes and parameters in EEPROM, which made UC-2A can store data safely for long period without backup power supply.

The control unit uses LED monitor and LED signal lights to show information. It is easy for operation.

Factory settings on UC-2A are as followings:

Pause mode:	timer
Pause time:	1 min
Lube mode:	counter
Lube impulses:	10
Electrifying time	0.2 s
Pitch adjustment	1:1
System monitoring:	Level monitoring

Without our written permission, any forms of translation, excerpt, copy, print and reproduce of this USER MANUAL and its content is prohibited. We reserve all rights to this USER MANUAL. We reserve the right to revise it without prior notice.

Manufacturer: Suzhou Leetern Industry Control Department
Address: Rm.102, Building 8, No. 22, Xiao Shi Jia Nong, Suzhou, China
Technical Support Fax: +86-512-68661838
Technical Support Email Box: support@leetern.com
Website: <http://www.leetern.com>

Contents

Safety Warning!

1. Installation
 - 1.1 Installation dimensions
 - 1.2 Electrical connection

2. Display and control panel
 - 2.1 LED monitor
 - 2.2 LED signal lights
 - 2.3 Keys
 - 2.4 Fault indicator relay SR

3. Operation guide
 - 3.1 Display operation
 - 3.2 Programming operation

4. Operation modes
 - 4.1 Timer operation
 - 4.2 Counter operation
 - 4.3 Pump's action adjustment
 - 4.4 System monitoring

5. Faults
 - 5.1 Level monitoring
 - 5.2 Fault display
 - 5.3 Fault message clearance

6. Technical data

Safety Warning!

Universal Control Unit UC-2C is designed and manufactured not only in conformity with the generally engineering standards, industrial safety and accident prevention regulations, but also in accordance with some relevant generally industrial technical acceptance standards.

Although this unit complies with relevant safety technical requirements, the use of the unit may still entail dangers leading to personal injury of the user or third parties or damage to property. Therefore, the unit must be used when it is in perfect technical condition. And the operation must strictly comply with operation manual. Errors that may affect safety must be rectified immediately.

The unit is designed for controlling and monitoring centralized lubrication systems. The user himself shall be liable for any damage caused by improper use.

Potential electrical dangers

This unit must be connected to the power supply only by trained qualified personnel in accordance with the local electric technical regulations. Improper connection may lead to serious personal injury.

UC-2C is suitable for conveyor, escalator and lubrication station, to control lubrication system that driven by single-phase AC power or similar electrical system. When it is used for any other purposes, all safety regulations should be complied with.

Note: The area that is circled by white heavy line on PCB is high voltage dangerous area. It is prohibited to touch directly with hand or with tools to avoid the danger of electric shock.

Qualified personnel

Qualified person means person trained, assigned and instructed by the operator of the equipment concerned. They are familiar with relevant safety rules or regulations and have certain knowledge and skills of safety. They are entitled to carry out the activities required in a given case and will be able to recognize and avoid possibly existing dangers.

1. Installation

Universal Control Unit UC-2A is **not** designed to work in open-air. It has to be installed in the room or in switch box to protect it from environmental influences.

Control panel component is designed with O ring seal groove. With O ring sealant and proper mounting hole, it can reach very high protection level.

If the control unit is installed at an inaccessible position, it is advisable to install additional pilot lights in operation room so that the operation situation of the system can be remote monitored.

UC-2A must be installed after Class II over-voltage electrical equipment, which supplies over-voltage protection. It is prohibited to install UC-2A directly to a bus bar or a trunk line.

1.1 Installation dimension

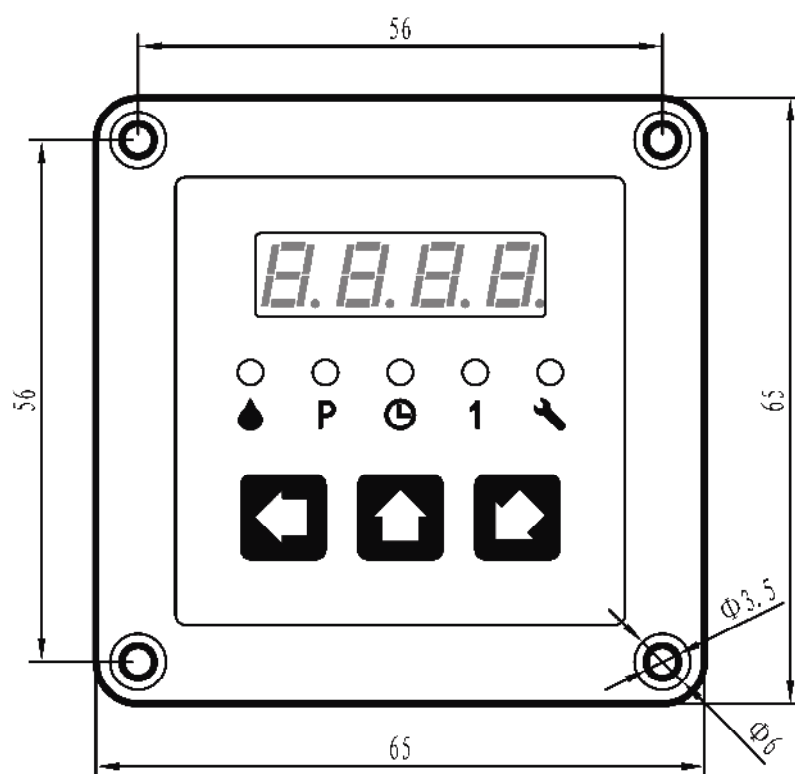

PANEL CUT-OUT diagram

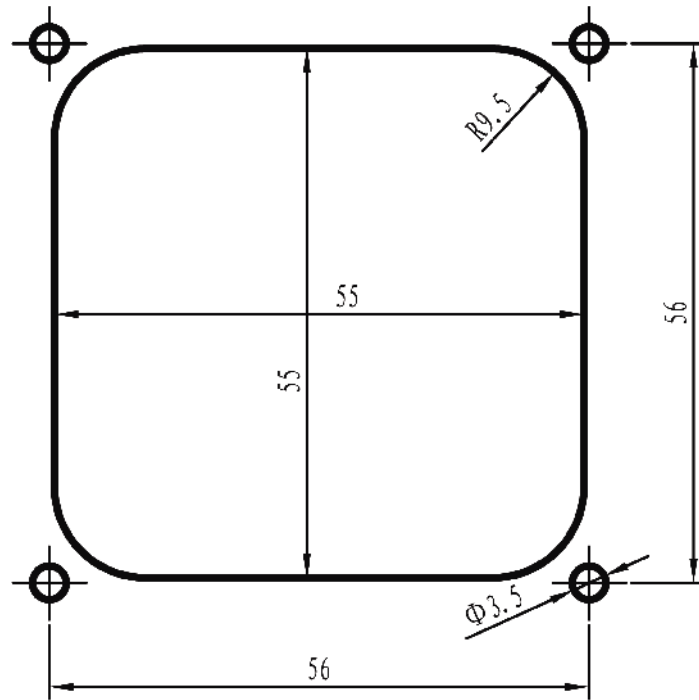

Outline dimension of control board

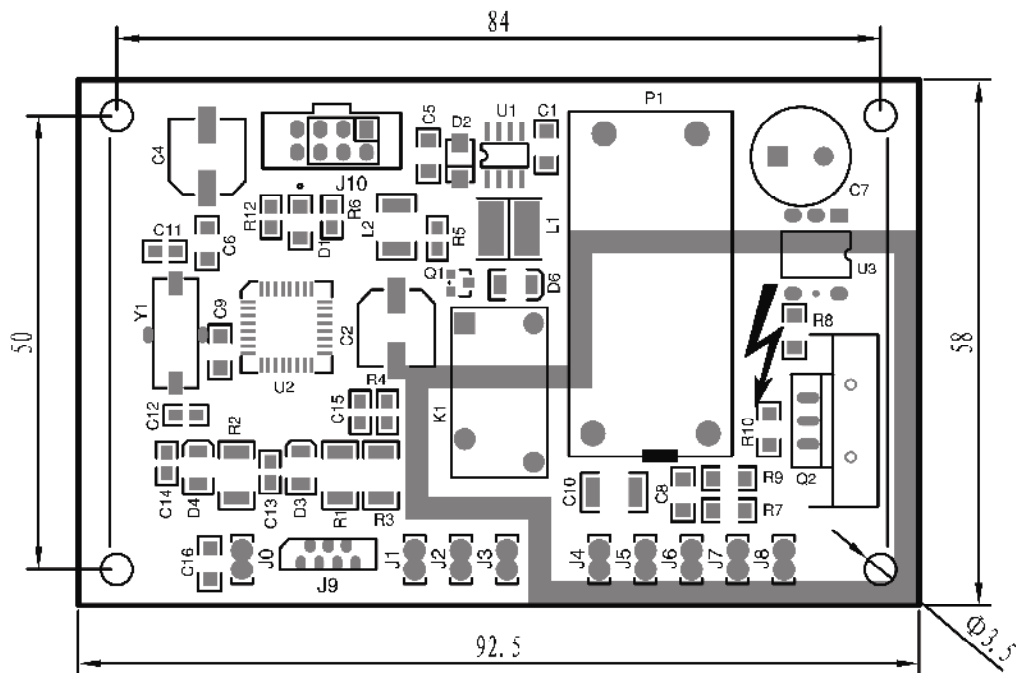

1.2 Electrical connection

J0 - GND	GND (PE)
J1 - LL	Level switch
J2 - MK	Signal input
J3 - V+	DC +24V power
J4 - SR	Status relay output
J5 - PUMP_L	Pump output _L
J6 - PUMP_N	Pump output _N
J7 - AC_N	Neutral wire (AC)
J8 - AC_L	Live wire
J9 - PANEL	To operation panel
J10 - TEST	Test interface

Electrical connection diagram

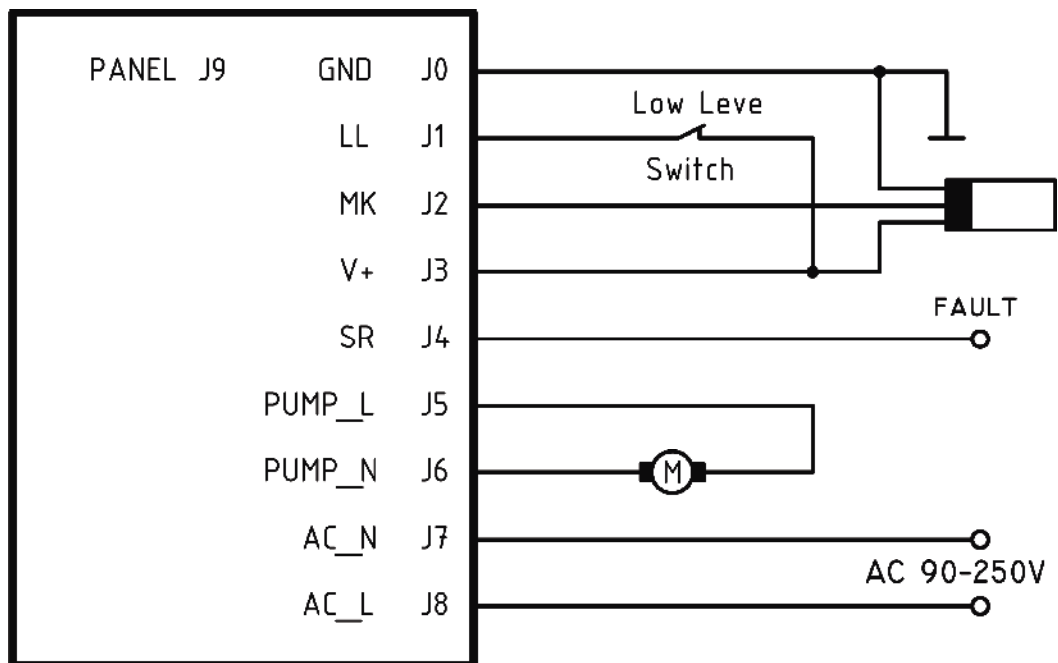

Note:

When UC-2A is in use, be sure the system voltage is within voltage limit range. Power voltage fluctuation should be in the scope of 90V~250V. Lower or higher than the voltage limit for long time will permanently damage the control unit.

If controller is installed on a metal baseboard, an 8mm (at least) net safety space between the metal baseboard and control board should be guaranteed to avoid the danger of electric shock.

2. Display and control panel

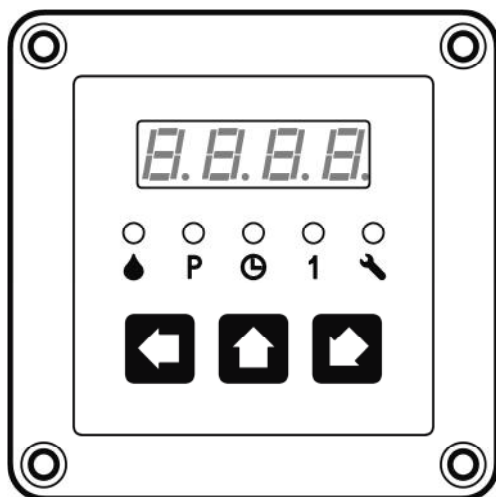

Film panel protects UC-2A from humidity and dust.

Please use soft cloth with warm water or neutral detergent to clean the film panel. Organic solvent is prohibited.

To avoid damage to the panel, do not use sharp tools/ object to touch it.

Please do not peel off the protection film before its final installation.

2.1 LED monitor



LED monitor displays operating status and parameters.

2.2 LED signal lights



PAUSE : Pause indicator light.

LED "PAUSE" is on: Power is supplied to pump and control unit. System is in PAUSE phase.

In programming, Light PAUSE on means the current programmed parameters relate to PAUSE.

"Light on" mentioned in this manual means the indicator light is a steady light. "Light flashes" means indicator light flashes by a frequency of 0.5s on and 0.5s off.



LUBE : Lubricating signal light

LED "LUBE" on: Power is supplied to pump and UC-2C. System is now in lubrication status.

In programming, Light LUBE on means the current programmed parameter relates to LUBE

 **TIMER**: TIMER mode indicator light

LED light "TIMER" on: the current phase is now in TIMER control mode. In programming, Light TIMER flashes means the control mode can be changed.

 **COUNTER** mode indicator light

LED "COUNTER" on: System is now in COUNTER control mode. In programming mode, Light COUNTER flash means the control mode can be changed.

 **FAULT**: Fault indicator light

LED "FAULT" flash means fault occurs in the lubrication system.

2.3 Keys

 **UP KEY**

With key , to increase the displayed value at cursor position by 1 in programming state. If the digit is already 9, then it will return to 0.

 **LEFT KEY**

To move left the cursor position when input parameters in programming status. If the cursor is already at the leftmost bit, then press this key, the cursor will return to the rightmost position.

 **SET KEY**

Activate programming mode. Confirm options or parameters.

When system is in FAULT state, briefly press this key to exit error state after troubleshooting.

NOTE: Programming operation can only be carried out when the system at normal condition. If the system is in FAULT state, then troubleshooting needs to be done first.

2.4 Fault relay SR

Fault relay SR is used to indicate the fault status of the controller. If controller detects error, SR will close and output AC power, to indicate that the lubrication system is now in abnormal condition.

* In programming mode, if no key operations for more than 2 minute, LED turns off automatically and quit current operation.

3. Operation guide and programming

Controller shows operational parameters and states via LED monitor and LED pilot lights. User may change the preset parameters with keys (buttons) on control panel.

If PAUSE is set as TIMER mode, the measurement unit of the figure on LED monitor is minute. If PAUSE is set as COUNTER mode, the figure on LED monitor is impulses number. Value for LUBE is fixed as counting times.

3.1 Display operation

LED pilot lights indicate current operation status and control mode. LED monitor displays the remaining value of the current status.

Example : System is now in PAUSE phase, Timer mode, and remaining value is 360 min (6 hours)

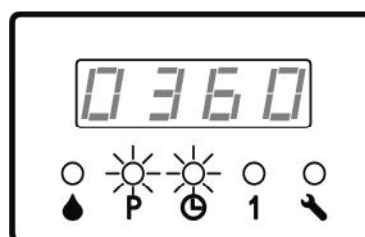

If system is in LUBE phase, the condition of control panel will be shown like the right figure.

This figure shows the remaining LUBE value is 10 impulses. And LUBE mode is fixed as COUNTER mode.

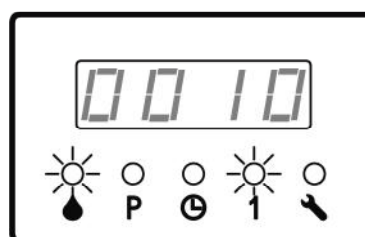

Please refer to chapter "Error status display and instruction" for details.

3.2 Programming

1. Press  longer than 2 seconds, LED monitor shows "PAU", light PAUSE on, meanwhile, indicator light TIMER or COUNTER is flashing to indicate preset PAUSE control mode.

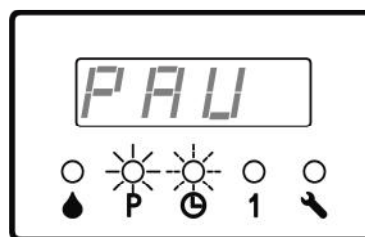

2. Use key  to change PAUSE control mode, then the relative light TIMER or COUNTER will flash accordingly

Example: Change PAUSE control mode to TIMER mode.

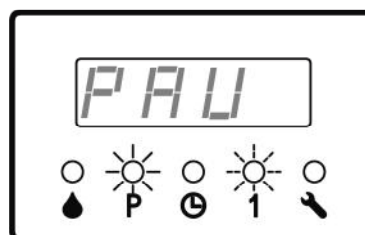

3. Press key  to confirm the new control mode. LED monitor then display preset PAUSE control value.

Example: 1 min (factory setting)

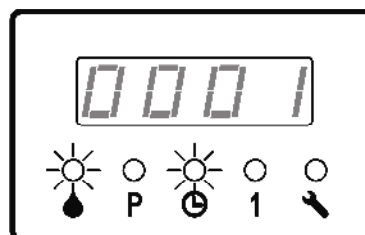

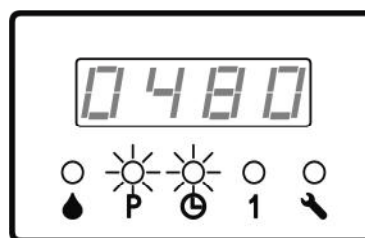

4. User may use keys   to change PAUSE value.

Example: change to 480 min (8 h)

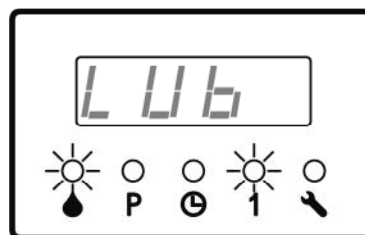

5. Press key  to confirm the new PAUSE value. LED monitor then shows "LUB", light PAUSE goes off, light LUBE on. Now user can modify LUBE parameters.



6. Press key , LED monitor displays preset LUBE parameters.

Example: 10 impulse (factory setting)

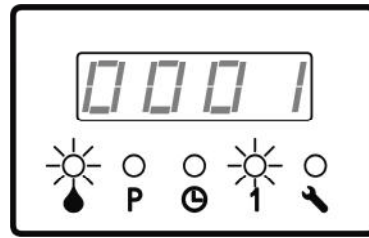

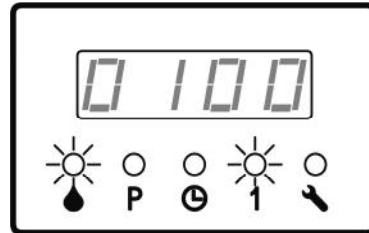

7. Use keys   to change LUBE control parameters .

Example: change to 10 impulse

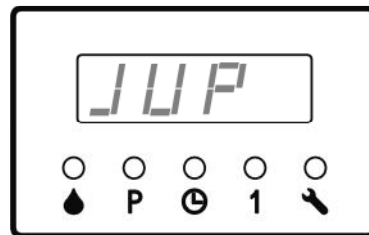

8. Press key  to confirm the new LUBE parameter. Then all lights off, LED displays JUP. User can program pitch ratio control value.



9. Press key , LED monitor displays current pitch ratio control value.

Example: 0001 (factory setting)

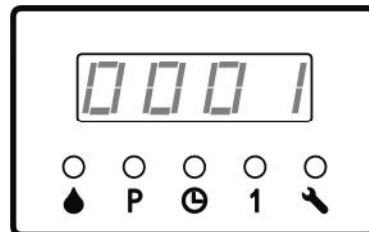

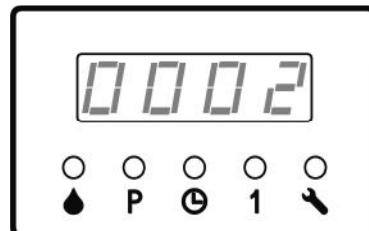

10. Use keys   to modify the pitch ratio control value.

Example: Change to 0002.

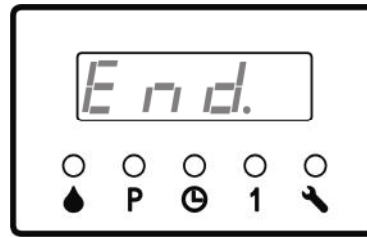

11. Press key  to confirm the new setting, LED monitor then displays 'End.', which means all setting are finish.



12. Press key  to end the setting operation and get back to display mode. The newly set parameters will be saved permanently until next change via setting.

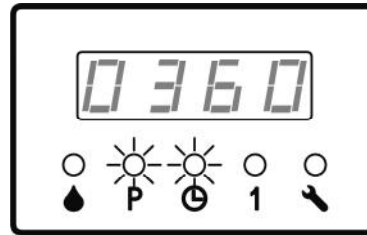

4. Operating modes

In order to meet different needs in different lubrication control applications, controller UC-2A supports multiple operating modes.

4.1 Timer operating mode

Set "TIMER" mode for PAUSE. After controller carry out the programmed PAUSE time, it begins to detect sensor impulses and carries out LUBE task based on the programmed LUBE impulses. When the programmed LUBE impulse number is reached, UC-2A goes to PAUSE timing process again and performs the cycle control of "PAUSE – LUBE – PAUSE".

4.2 Counter operating mode

If PAUSE is set as COUNTER mode, after controller carry out the programmed impulses numbers, it carries out LUBE task based on programmed LUBE impulses. When the programmed LUBE impulse number is reached, controller goes to PAUSE counting process again and performs the cycle control of "PAUSE – LUBE – PAUSE "

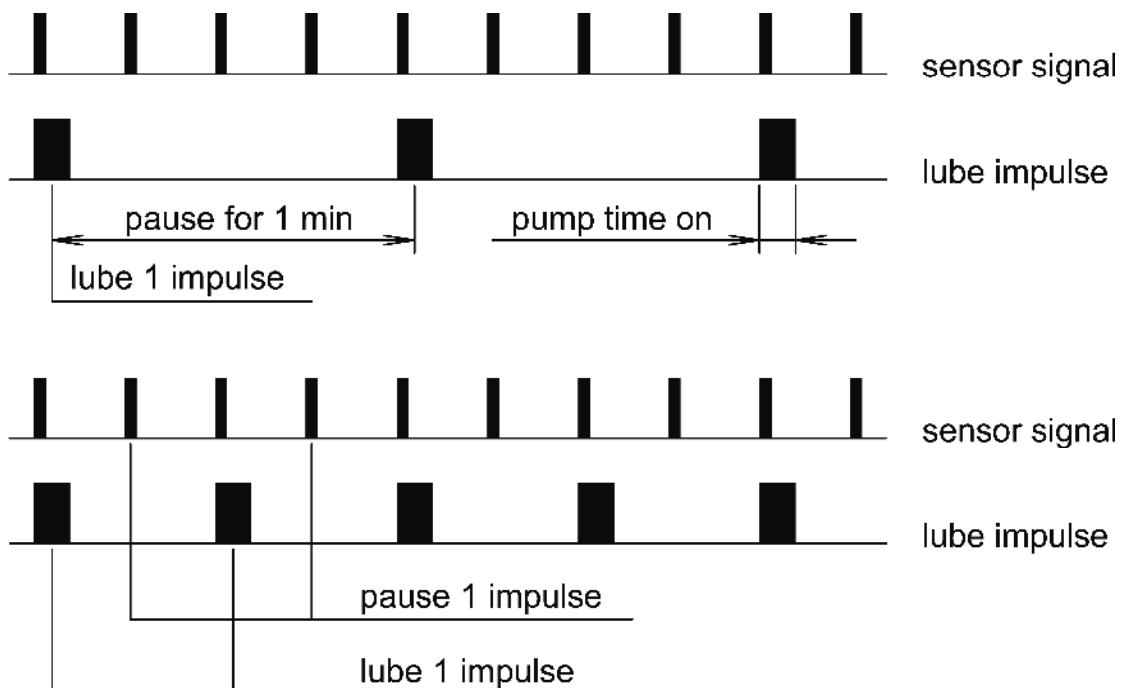

COUNTER mode is the only operation mode for LUBE.

4.3 Pitch adjustment

Oil projection action performs by tracking sensor-signal impulses. If the impulses are too dense, and pump is required to project oil by tracking each impulse, this would lead to the pump cannot track signals successfully. This result in the oil projection cannot be performed properly. Typical phenomenon is pump stay electrifying status and will not release.

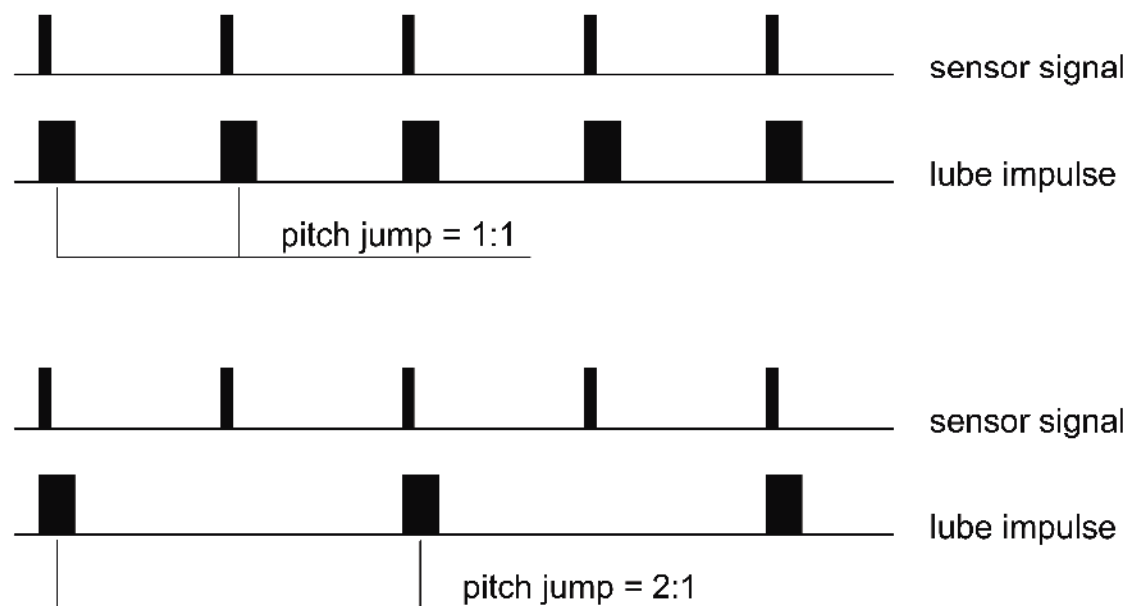

User can eliminate this phenomenon by proper pitch jump setting. After setting pitch jump value, controller performs oil projection and lubrication movement once every N pitches as show in figure above.

5. Faults

When control unit detects faults, light "FAULT" on the panel will be flashing quickly. Meanwhile, the fault indicator relay closes and outputs AC power to remind user the lubrication system is in fault condition. Control unit stops normal operation and waiting for user to handle the faults. User may check the detailed fault reason on LED monitor.

5.1 Level monitoring

Controller can monitor the level situation of the reservoir via level switch. When level is lower than a certain level, level switch will open. Once the controller detects the level switch opens, it gives alarm immediately and all LUBE channels stop at the same time.

Level monitoring function is activated all the time. It cannot be deactivated via setting. If user DOES NOT need this level monitoring function, they can short circuit terminal J1 and J3 on the control board.

5.2 Faults display

Whenever controller detects fault, LED monitor will display corresponding error code and meanwhile light FAULT on the panel flashes. The contact of the fault relay inside controller will close, and transfer the fault signal to control room or other connected control system.

When fault occurs, the information displayed on LED monitor may be as follow figures:

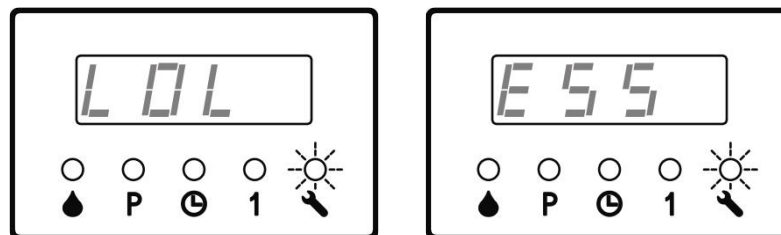

Left figure 'LOL' means **Low Oil Level** fault occurs.

Right figure 'ESS' means error occurs in the system. In this condition, please cut the power to the controller for 1 minute, if the error still exists when electrify it again, please contact manufacturer.

5.3 Clear fault messages

After the error being handled, briefly press key  on the panel to clear the error message, exit fault state and gets back to normal lubrication circle.

If the reason that causes the error still exists, this operation does not work.

6. Technical specification

Operation voltage -----	90V~250V, 45~65Hz
Max. output -----	>3A
Pump current on time -----	0.2s
LUBE counting times -----	1~9999
PAUSE time -----	0~9999 min
PAUSE counting times-----	0~9999
Pitch ratio -----	1:1~99:1
External input signal -----	10V ~30V DC, input equivalent resistance of 10k
Fault relay output -----	250V AC, 5A Max, N.O.
Operation temperature -----	-30°C ~+70°C