

USER MANUAL

KPM180H

TK180

CUSTOM[®]

CUSTOM S.p.A.
Via Berettine 2/B
43010 Fontevivo (PARMA) - Italy
Tel. : +39 0521-680111
Fax : +39 0521-610701
http: www.custom.biz

Customer Service Department:
Email : support@custom.it

© 2014 CUSTOM S.p.A. – Italy.
All rights reserved. Total or partial reproduction of this manual in whatever form, whether by printed or electronic means, is forbidden. While guaranteeing that the information contained in it has been carefully checked, CUSTOM S.p.A. and other entities utilized in the realization of this manual bear no responsibility for how the manual is used.
Information regarding any errors found in it or suggestions on how it could be improved are appreciated. Since products are subject to continuous check and improvement, CUSTOM S.p.A. reserves the right to make changes in information contained in this manual without prior notification.

The pre-installed multimedia contents are protected from Copyright CUSTOM S.p.A. Other company and product names mentioned herein may be trademarks of their respective companies. Mention of third-party products is for informational purposes only and constitutes neither an endorsement nor a recommendation. CUSTOM S.p.A. assumes no responsibility with regard to the performance or use of these products.

THE IMAGES USED IN THIS MANUAL ARE USED AS AN ILLUSTRATIVE EXAMPLES. THEY COULDN'T REPRODUCE THE DESCRIBED MODEL FAITHFULLY.

UNLESS OTHERWISE SPECIFIED, THE INFORMATION GIVEN IN THIS MANUAL ARE REFERRED TO ALL MODELS IN PRODUCTION AT THE ISSUE DATE OF THIS DOCUMENT.



The format used for this manual improves use of natural resources reducing the quantity of necessary paper to print this copy.

GENERAL SAFETY INFORMATION

Your attention is drawn to the following actions that could compromise the characteristics of the product:

- Read and retain the instructions which follow.
- Follow all indications and instructions given on the device.
- Make sure that the surface on which the device rests is stable. If it is not, the device could fall, seriously damaging it.
- Make sure that the device rests on a hard (non-padded) surface and that there is sufficient ventilation.
- When positioning the device, make sure cables do not get damaged.
- Use the type of electrical power supply indicated on the device label. If uncertain, contact your dealer.
- Make sure the electrical system that supplies power to the device is equipped with a ground wire and is protected by a differential switch.
- Do not block the ventilation openings.
- Do not insert objects inside the device as this could cause short-circuiting or damage components that could jeopardize printer functioning.
- Do not carry out repairs on the device yourself, except for the normal maintenance operations given in the user manual.
- Make sure that there is an easily-accessible outlet with a capacity of no less than 10A closely to where the device is to be installed.
- Periodically perform scheduled maintenance on the device to avoid dirt build-up that could compromise the correct, safe operation of the unit.
- Before any type of work is done on the machine, disconnect the power supply.
- Do not touch the head heating line with bare hands or metal objects. Do not perform any operation inside the printer immediately after printing because the head and motor tend to become very hot.

GENERAL INSTRUCTIONS

CUSTOM S.p.A. declines all responsibility for accidents or damage to persons or property occurring as a result of tampering, structural or functional modifications, unsuitable or incorrect installations, environments not in keeping with the equipment's protection degree or with the required temperature and humidity conditions, failure to carry out maintenance and periodical inspections and poor repair work.



THE CE MARK AFFIXED TO THE PRODUCT CERTIFY THAT THE PRODUCT SATISFIES THE BASIC SAFETY REQUIREMENTS.

The device is in conformity with the essential Electromagnetic Compatibility and Electric Safety requirements laid down in Directives 2006/95/CE and 2004/108/CE inasmuch as it was designed in conformity with the provisions laid down in the following Standards:

- EN 55022 Class B (*Limits and methods of measurements of radio disturbance characteristics of Information Technology Equipment*)
- EN 55024 (*Information Technology Equipment – Immunity characteristics – Limits and methods of measurement*)
- EN 60950-1 (*Safety of information equipment including electrical business equipment*)



GUIDELINES FOR THE DISPOSAL OF THE PRODUCT

The crossed-out rubbish bin logo means that used electrical and electronic products shall NOT be mixed with unsorted municipal waste. For more detailed information about recycling of this product, refer to the instructions of your country for the disposal of these products.

- Do not dispose of this equipment as miscellaneous solid municipal waste, but arrange to have it collected separately.
- The re-use or correct recycling of the electronic and electrical equipment (EEE) is important in order to protect the environment and the wellbeing of humans.
- In accordance with European Directive WEEE 2002/96/EC, special collection points are available to which to deliver waste electrical and electronic equipment and the equipment can also be handed over to a distributor at the moment of purchasing a new equivalent type.
- The public administration and producers of electrical and electronic equipment are involved in facilitating the processes of the re-use and recovery of waste electrical and electronic equipment through the organisation of collection activities and the use of appropriate planning arrangements.
- Unauthorised disposal of waste electrical and electronic equipment is punishable by law with the appropriate penalties.

POWER SUPPLY INFORMATION

The device is fed by a SELV power supply (Safety Extra Low Voltage).

When power supply unit is installed as accessory in the end-product, the following items must be considered:

- The power supply must be properly bonded to the main protective earthing termination.
- A suitable mechanical, electrical and fire enclosure must be provided.
- The power supply has been evaluated for use in a pollution degree 2 environment, overvoltage category II.
- An appropriate disconnect device must be provided.
- The power supply must be installed in compliance with the mounting, creepage, clearance, markings and segregation requirements of the end-use application.

WARNING: PRESENCE OF DANGEROUS VOLTAGES (POWER SUPPLY)

Risk of electric shock (accessory power supply).

WARNING: PRESENCE OF HAZARDOUS MOVING PARTS

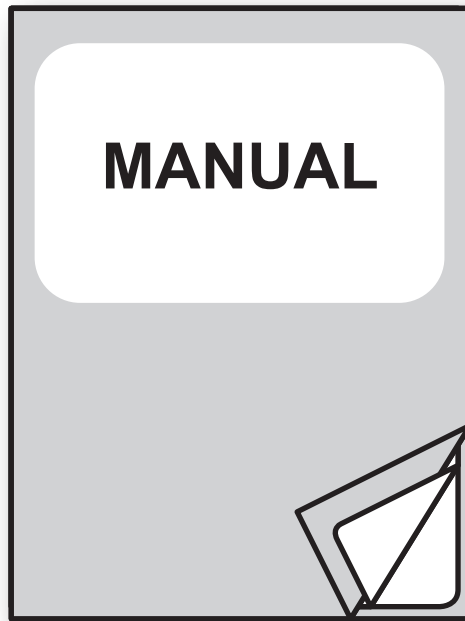

For details on the commands,
refer to the manual with code **77200000001800**

TABLE OF CONTENTS

1	INTRODUCTION	9
1.1	Document structure	9
1.2	Explanatory notes used in this manual	9
2	DESCRIPTION	11
2.1	Box contents	11
2.2	Device components: external views	15
2.3	Device components: keys and connectors panel	19
2.4	Device components: internal views	20
2.5	Product label	22
2.6	Key functions: power up	23
2.7	Key functions: standby	25
2.8	Status LED flashes	26
2.9	Display messages	27
3	INSTALLATION	29
3.1	Fastening	29
3.2	Near paper end sensor	34
3.3	Connections	36
3.4	Pinout	38
3.5	Driver and SDK	42
4	OPERATION	43
4.1	Opening cover	43
4.2	Adjusting paper width	45
4.3	Adjusting the alignment sensors	46
4.4	Switch the device ON	48
4.5	Loading the paper roll	51
4.6	Issuing ticket (models with presenter)	54
5	CONFIGURATION	59
5.1	Configuration mode	59
5.2	Setup report	60
5.3	Device status	62
5.4	Printer parameters	63
5.5	Ethernet parameters	68
5.6	Hexadecimal dump	69

6	MAINTENANCE	71
6.1	Printer paper jam	71
6.2	Cutter paper jam	72
6.3	Planning of cleaning operations	74
6.4	Cleaning	75
6.5	Upgrade firmware	79
7	SPECIFICATION	81
7.1	Hardware specifications	81
7.2	Character specifications in CUSTOM/POS emulation	84
7.3	Device dimensions	85
7.4	Device dimensions with paper roll holder	89
7.5	Dimensions of paper roll holder cod. 963GE020000003	91
7.6	Dimensions of power supply cod. 963GE020000003	92
7.7	Paper specification	93
7.8	Character sets in CUSTOM/POS emulation	95
7.9	Character sets in SVELTA emulation	97
8	CONSUMABLES	99
9	ACCESSORIES	101
10	ALIGNMENT	103
10.1	Enable alignment	104
10.2	Calibration	107
10.3	Alignment parameters	110
10.4	Printing area	114
11	TECHNICAL SERVICE	117
12	ADVANCED FUNCTIONS	119
12.1	File sharing	119
12.2	Drivers installation	119
12.3	Logos management	120
12.4	Fonts management	120
12.5	Setup	121

1 INTRODUCTION

1.1 Document structure

This document includes the following chapters:

1	INTRODUCTION	information about this document
2	DESCRIPTION	general description of device
3	INSTALLATION	information required for a correct installation of the device
4	OPERATION	information required to make the device operative
5	CONFIGURATION	description of the configuration parameters of the device
6	MAINTENANCE	information for a correct periodic maintenance
7	SPECIFICATION	technical specification for the device and its accessories
8	CONSUMABLES	description and installation of the available consumables for the device
9	ACCESSORIES	description and installation of the available accessories for the device
10	ALIGNMENT	information required for managing the paper alignment
11	TECHNICAL SERVICE	information required for contacting the technical service
12	ADVANCED FUNCTIONS	information about special functions available with the device

1.2 Explanatory notes used in this manual

NOTE:

Gives important information or suggestions relative to the use of the device

ATTENTION:

Gives information that must be carefully followed to guard against damaging the device

DANGER:

Gives information that must be carefully followed to guard against operator injury or damage

2 DESCRIPTION

2.1 Box contents

Remove the device from its carton being careful not to damage the packing material so that it may be re-used if the device is to be transported in the future.

Make sure that all the components illustrated below are present and that there are no signs of damage. If there are, contact Customer Service.

KPM180H (standard models)

1. Installation instruction sheet
2. Device
3. Reducer for paper width
4. External near paper end sensor with cable

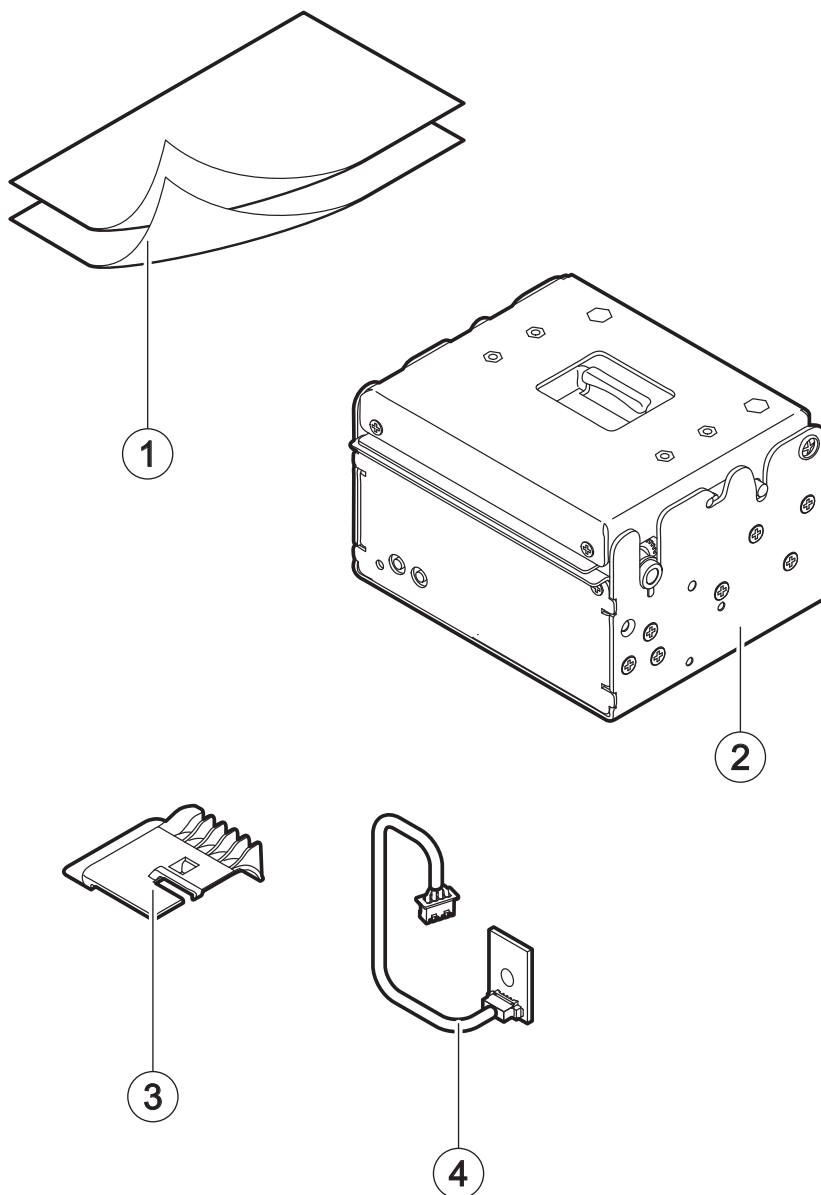

KPM180H (models with presenter)

1. Device
2. Installation instruction sheet
3. Reducer for paper width
4. External near paper end sensor with cable

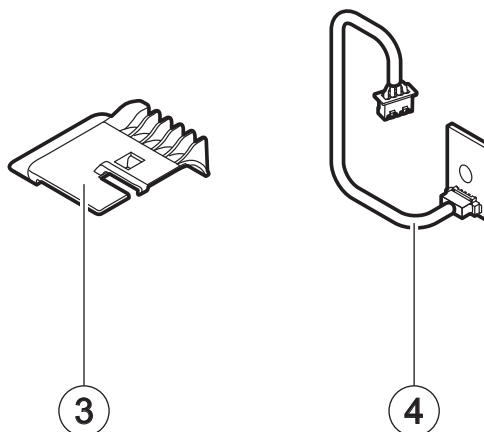
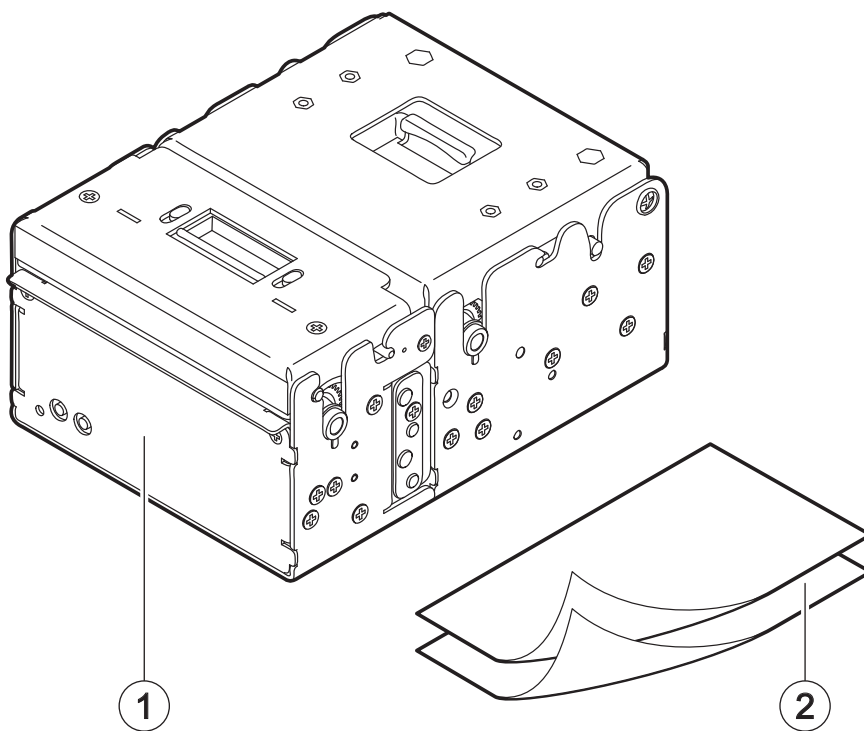

TK180 (metallic models)

1. Short guide
2. Device
3. AC adapter
4. Reducer for paper width
5. Serial cable
6. USB cable
7. External near paper end sensor with cable

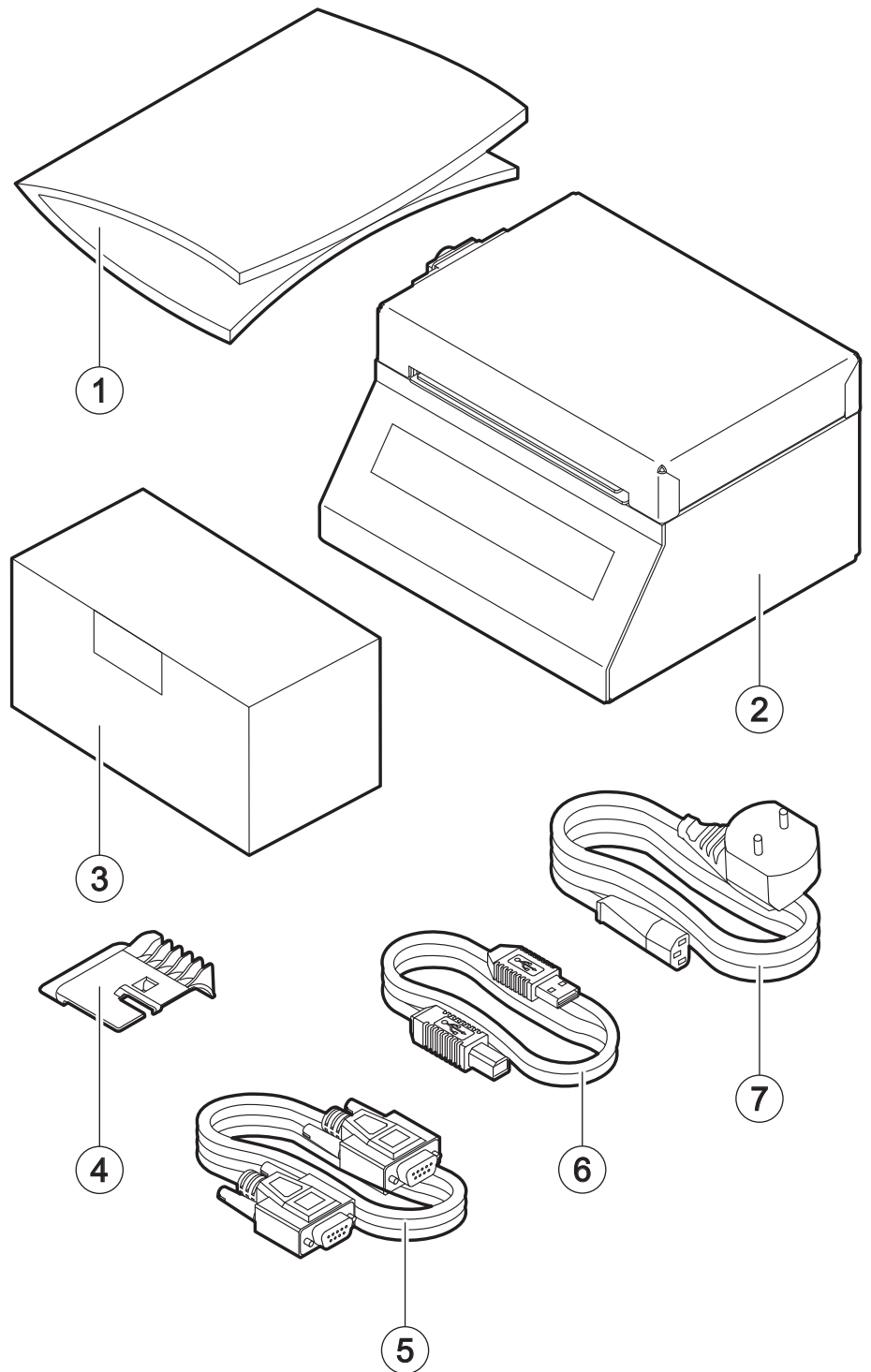

TK180 (plastic models)

1. Short guide
2. Device
3. AC adapter
4. Reducer for paper width
5. AC power cable

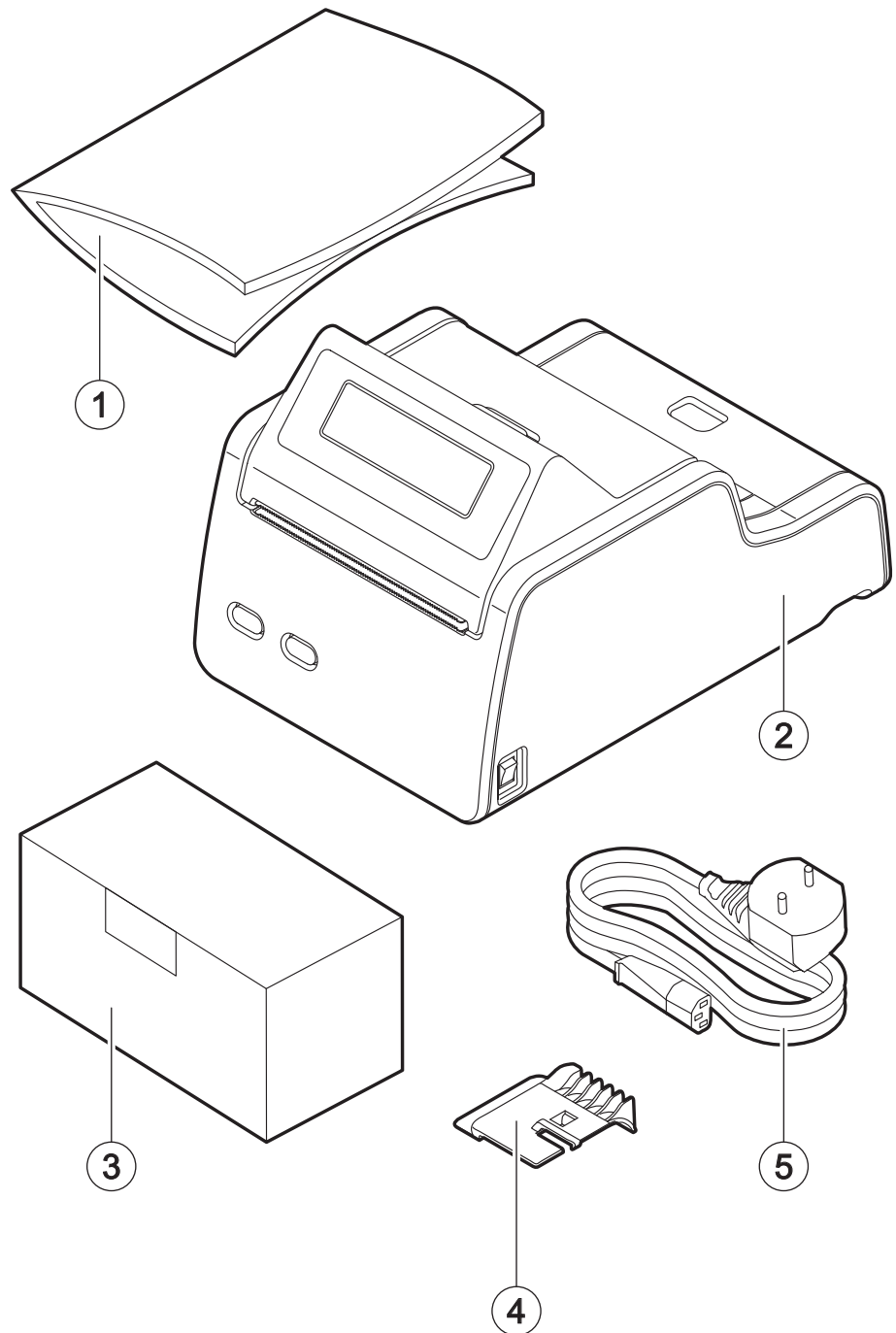

- Open the device packaging.
- Take out the device.
- Take out the rest of the content.
- Keep the box, trays and packing materials in the event the device must be transported/shipped in the future.

2.2 Device components: external views

KPM180H (standard models)

1. Device chassis
2. Device cover
3. Opening lever for device
1. Paper out
2. Status LED
3. LF LINE FEED key
4. FF FORM FEED key
5. Paper input
6. Adjustable cursor for paper in
7. Keys and connectors panel
(see following paragraphs)
8. Product label

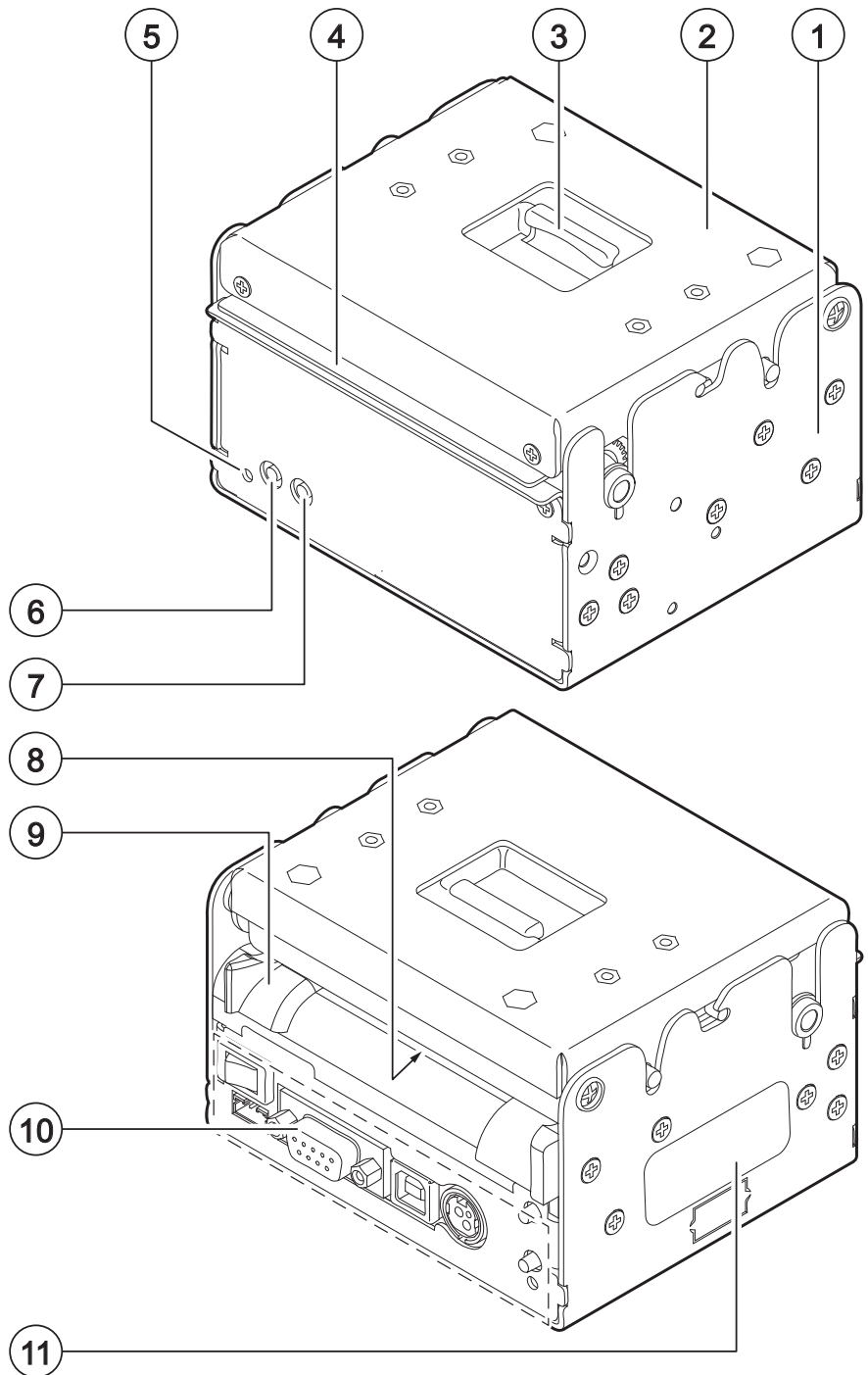

KPM180H (models with presenter)

1. Device chassis
2. Device cover
3. Opening lever for device
4. Opening lever for presenter
5. Paper out
6. Status LED
7. LF LINE FEED key
8. FF FORM FEED key
9. Presenter chassis
10. Paper input
11. Adjustable cursor for paper in
12. Keys and connectors panel
(see following paragraphs)
13. Product label

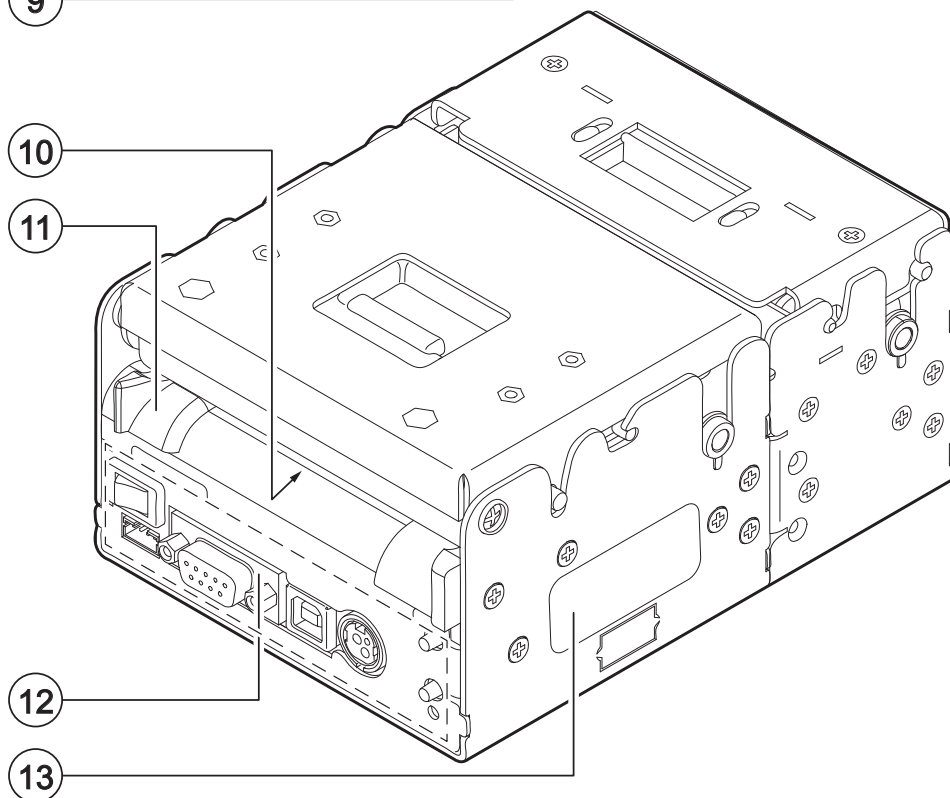
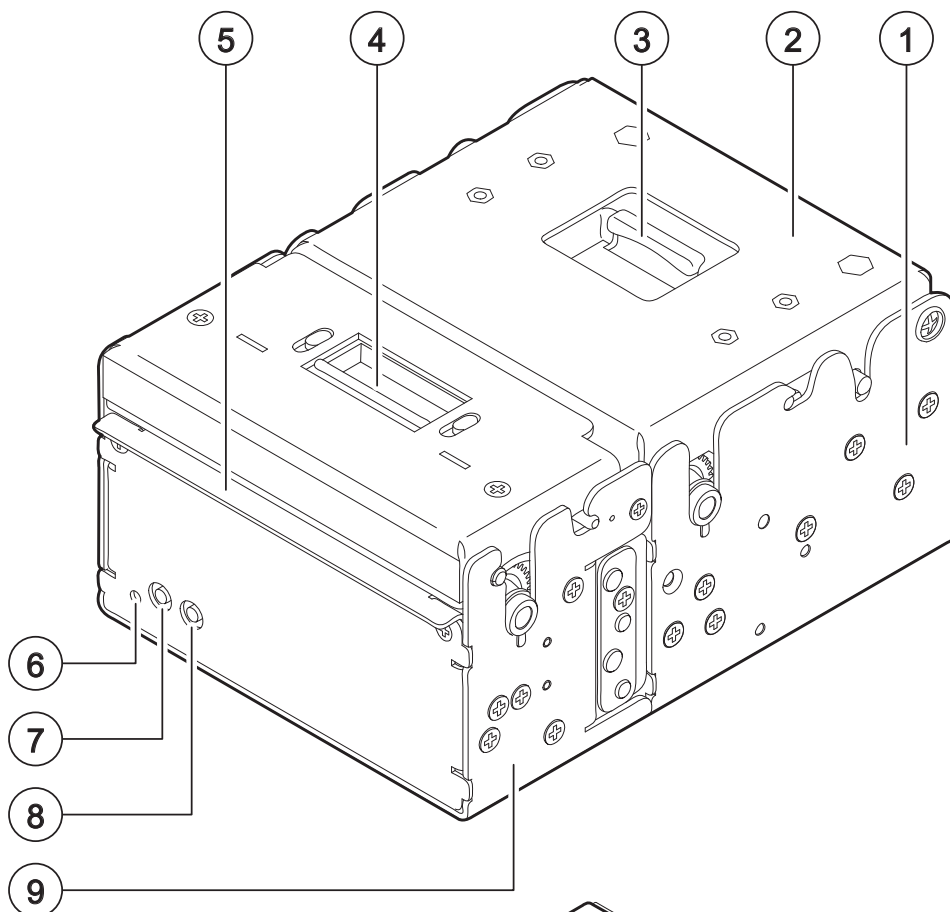

TK180 (metallic models)

1. Device chassis
2. Device cover
3. Paper out
4. Display
5. Paper input
6. Adjustable cursor for paper in
7. Keys and connectors panel
(see following paragraphs)

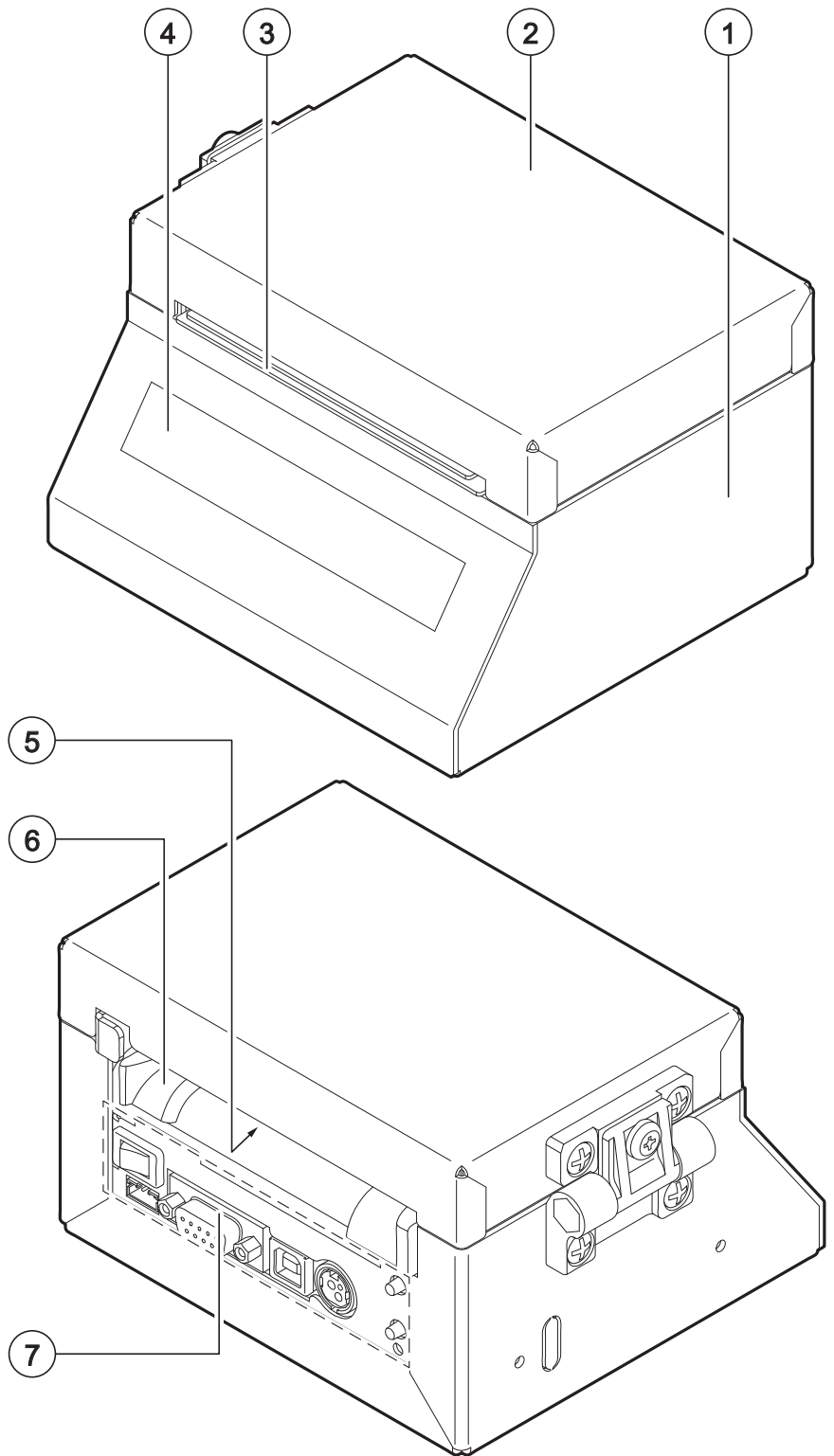

TK180 (plastic models)

1. Connectors cover
2. Display
3. Paper out
4. LF LINE FEED key
5. FF FORM FEED key
6. ON/OFF key
7. Device cover
8. Opening lever for device
9. Paper input
10. Adjustable cursor for paper in
11. Keys and connectors panel
(see following paragraphs)
12. Device chassis

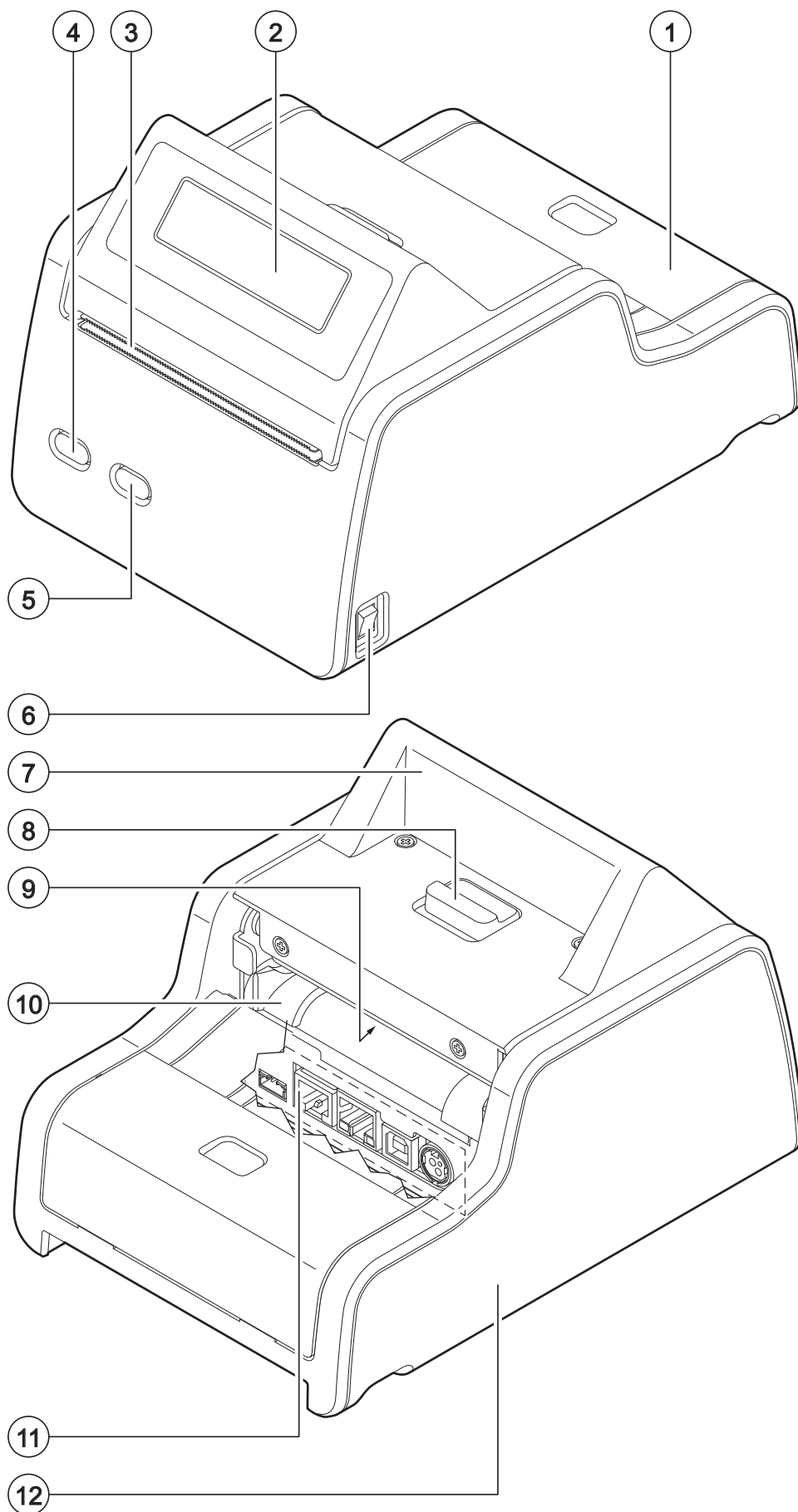

2.3 Device components: keys and connectors panel

Models without ETHERNET port

1. ON/OFF key (only for KPM180H and metallic TK180)
2. Connector for near paper end sensor (external)
3. RS232 serial port (DB9)
4. USB port
5. Power supply port
6. Status LED
7. FF FORM FEED key
8. LF LINE FEED key

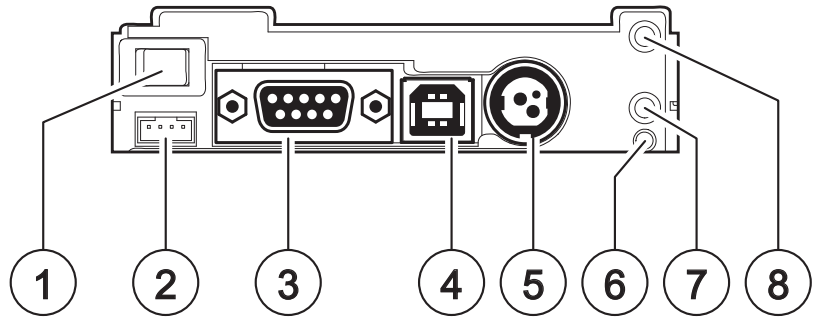

Models with ETHERNET port

1. ON/OFF key (only for KPM180H and metallic TK180)
2. Connector for near paper end sensor (external)
3. RS232 serial port (RJ45)
4. ETHERNET port
5. USB port
6. Power supply port
7. Status LED
8. FF FORM FEED key
9. LF LINE FEED key

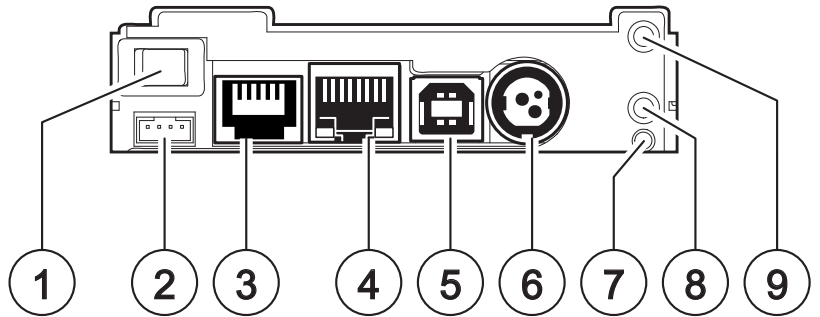

2.4 Device components: internal views

KPM180H (standard models), TK180

1. Printing head with temperature sensor
2. Upper mobile sensor for detecting black mark on the thermal side of paper or hole between tickets
3. Lower mobile sensor for detecting black mark on the thermal side of paper or hole between tickets
4. Sensors for detecting paper in presence
5. Sensor for cover opening detection
6. Sensors for detecting paper out presence

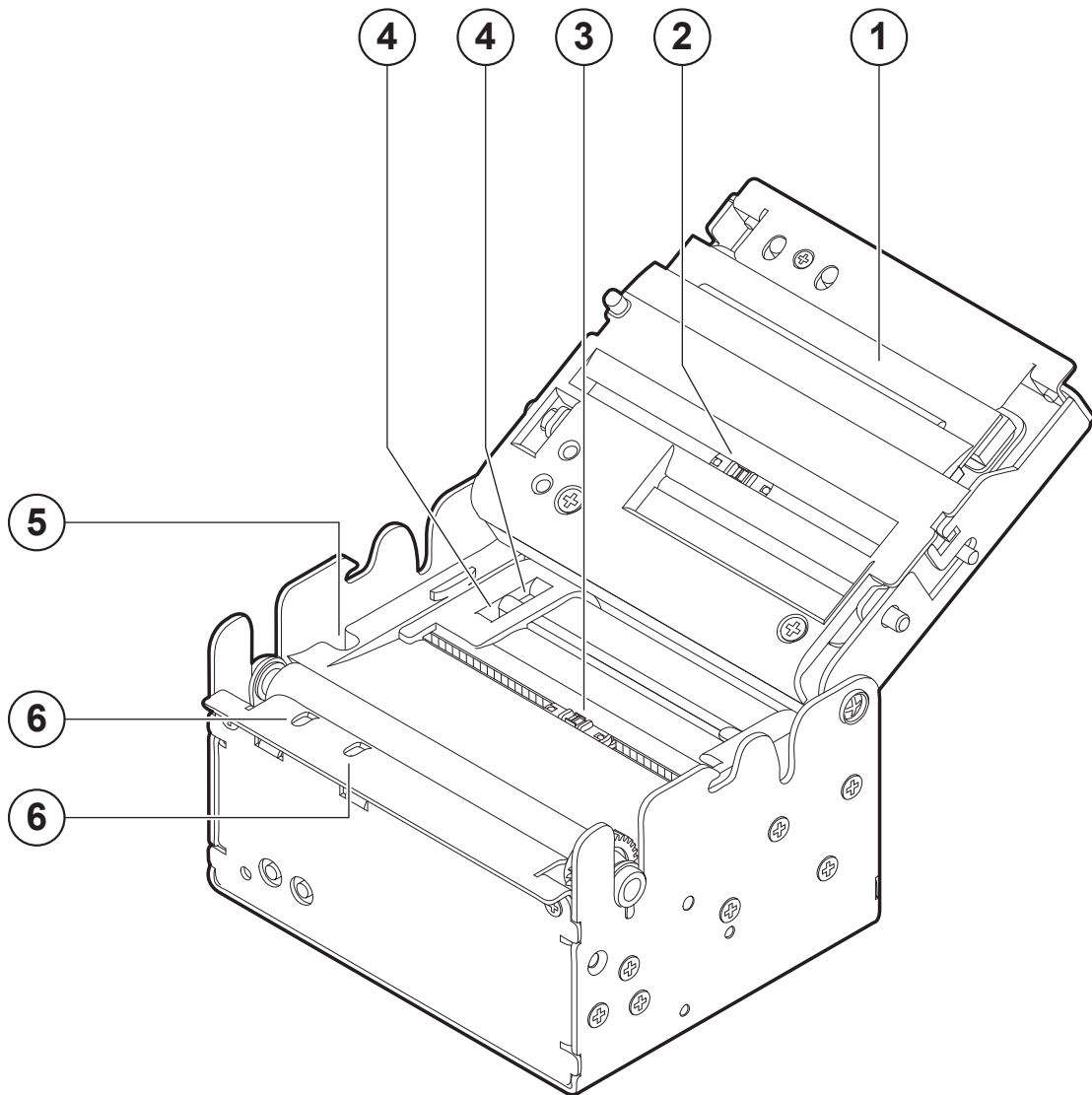

KPM180H (models with presenter)

1. Printing head with temperature sensor
2. Upper mobile sensor for detecting black mark on the thermal side of paper or hole between tickets
3. Lower mobile sensor for detecting black mark on the thermal side of paper or hole between tickets
4. Sensors for detecting paper in presence
5. Sensor for detecting the opening of device cover
6. Sensor for detecting the opening of presenter cover
7. Sensors for detecting paper out presence

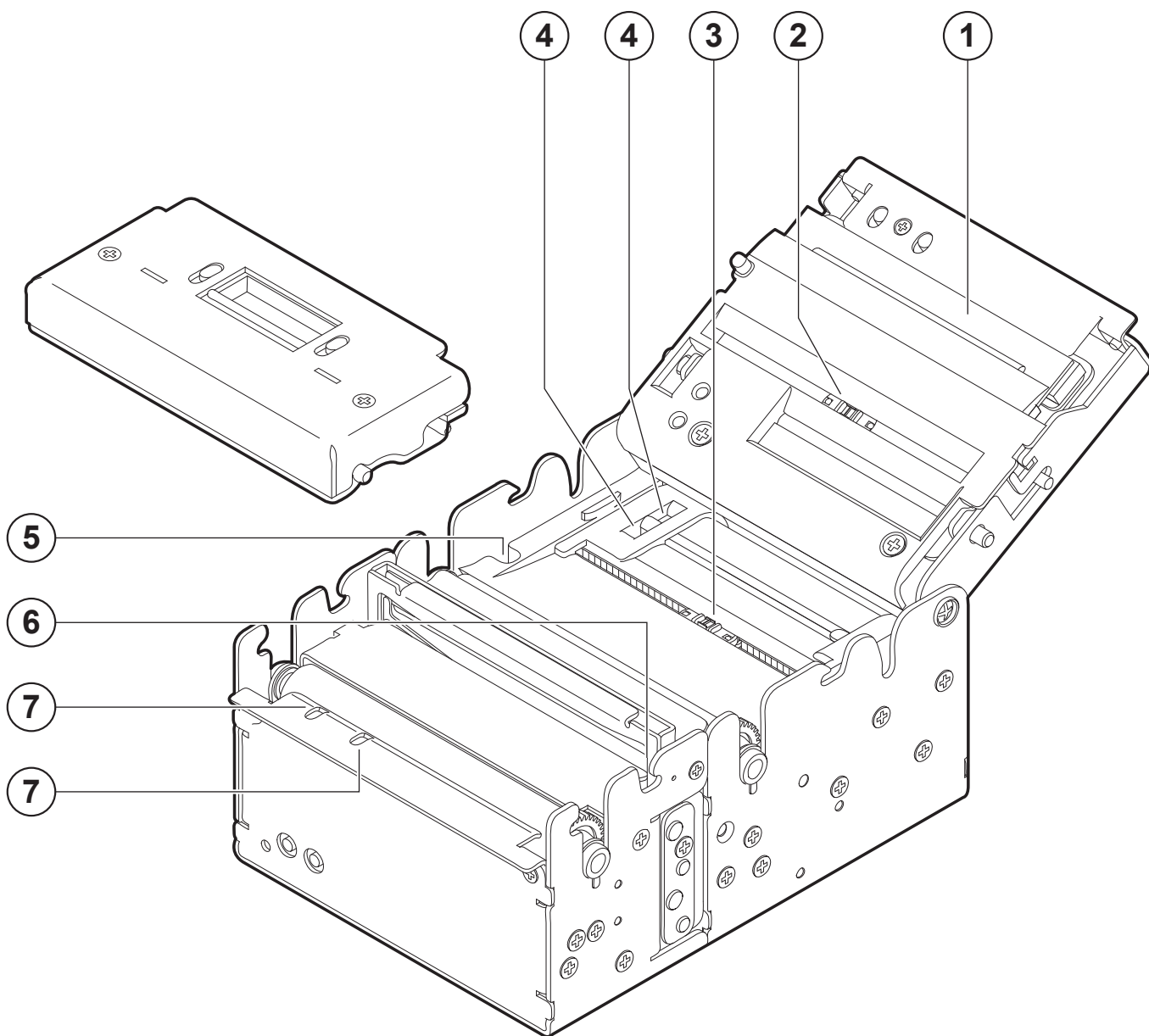

2.5 Product label

PC = Product code (14 digits)
SN = Serial number
HW = Hardware release

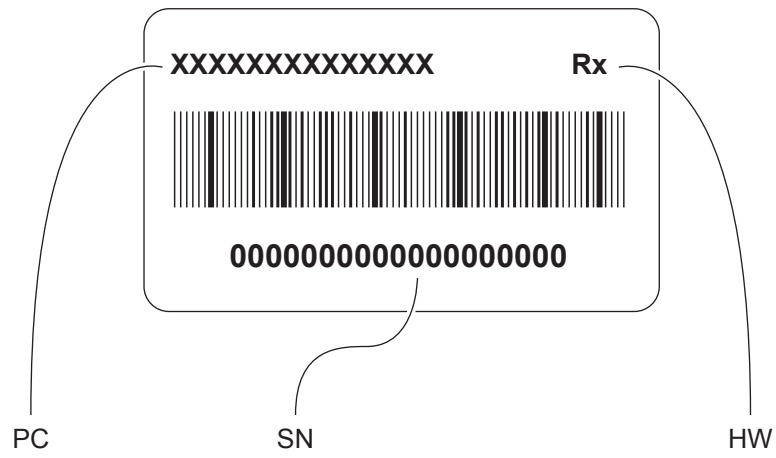

2.6 Key functions: power up

Models without ETHERNET port

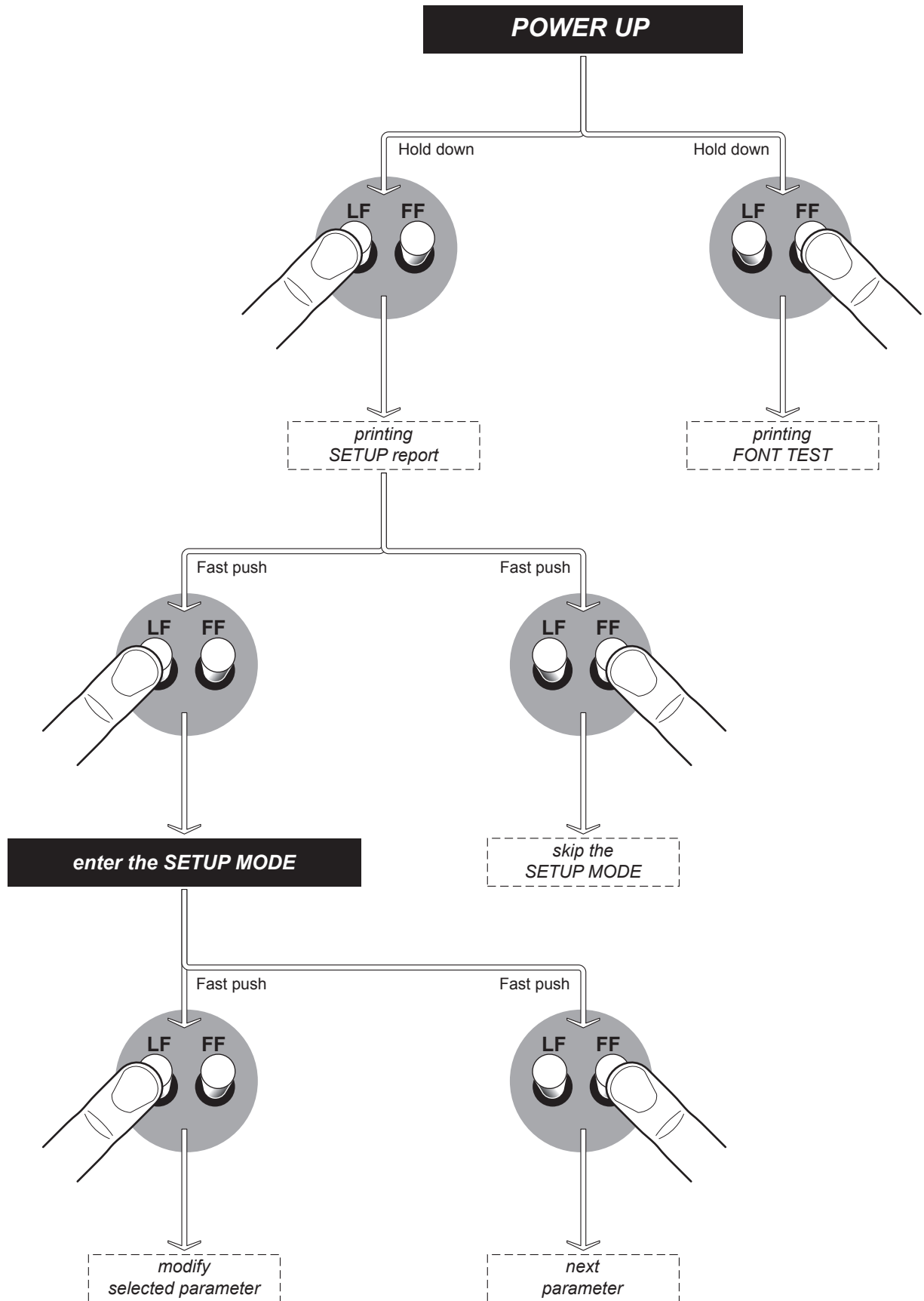

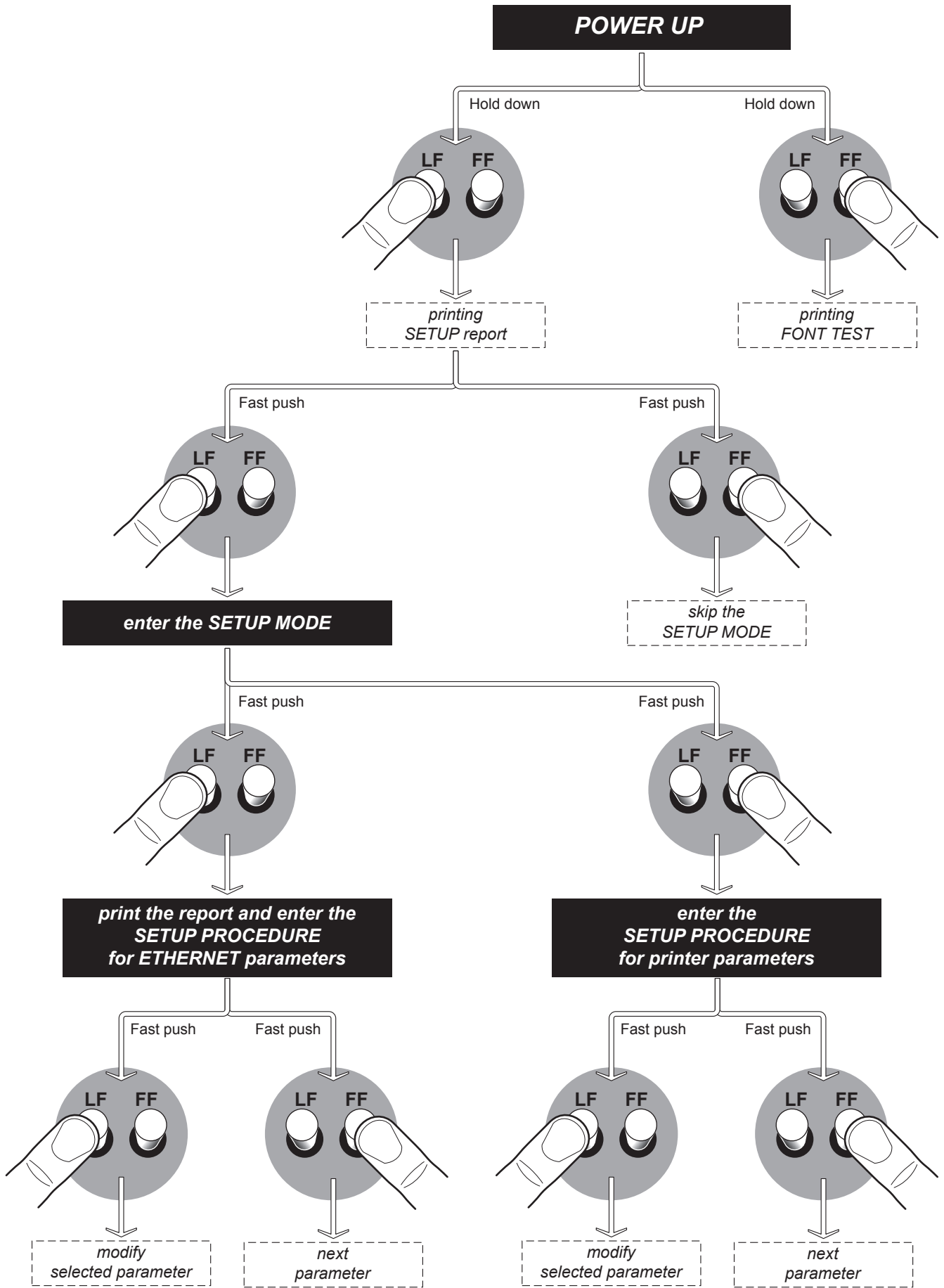



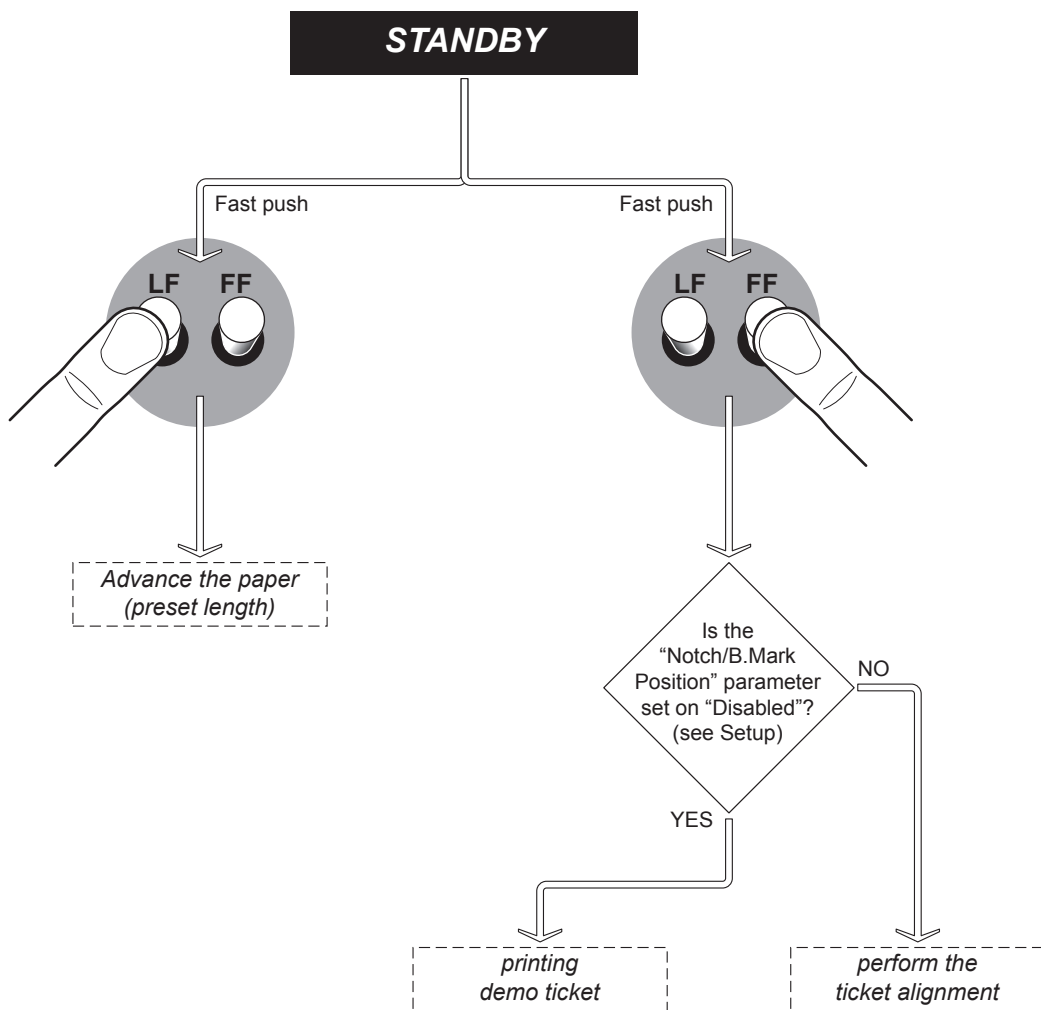

2.7 Key functions: standby



2.8 Status LED flashes

The Status LED indicates hardware status of device. Given in the table below are the various LED signals and the corresponding device status.

STATUS LED		DESCRIPTION	
-		OFF	DEVICE OFF
GREEN		ON	DEVICE ON: NO ERROR
GREEN COMMUNICATION STATUS		x 1	RECEIVE DATA
		x 2	RECEPTION ERRORS (PARITY, FRAME ERROR, OVERRUN ERROR)
		x 3	COMMAND NOT RECOGNIZED
		x 4	COMMAND RECEPTION TIME OUT
YELLOW RECOVERABLE ERROR		x 2	HEADING OVER TEMPERATURE
		x 3	PAPER END
		x 4	PAPER JAM
		x 5	POWER SUPPLY VOLTAGE INCORRECT
RED UNRECOVERABLE ERROR		x 6	COVER OPEN
		3 x	RAM ERROR

2.9 Display messages

TK180

The display indicates the hardware status of device. Given in the table below are the various display messages and the corresponding device status.

PRINTER READY Device ON: no error	RECEIVING DATA Receive data
RS232 RX ERROR Reception errors (parity, frame error, overrun error)	COMMAND ERROR Command not recognized
PRINTHEAD OVERTEMP Heading over temperature	END PAPER Paper end
PAPER JAM Paper jam	POWER VOLTAGE ERROR Power supply voltage incorrect
COVER OPEN Cover open	RAM ERROR RAM error
EEPROM ERROR EEPROM error	PRINT TICKET ERROR Notch alignment error
PRINTING DOCUMENT Printing in progress	

3 INSTALLATION

3.1 Fastening

NOTE: All the dimensions shown in following figures are in millimetres.

KPM180H (standard models)

The device is provided with four fixing holes on the bottom of device (see following figure). To fasten the device on a panel, use four M3 screws.

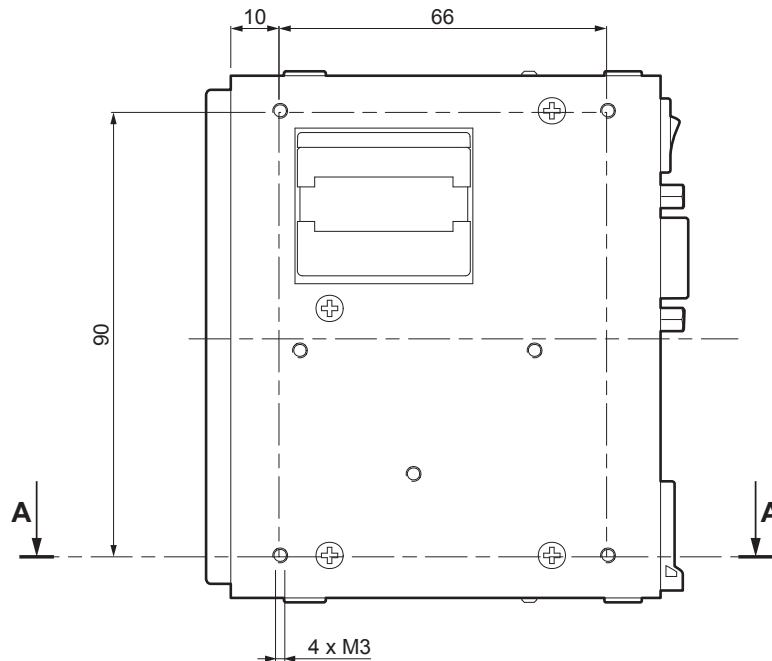

It's very important to consider the screws length not to damage the internal components placed near the fixing holes (see following figure).

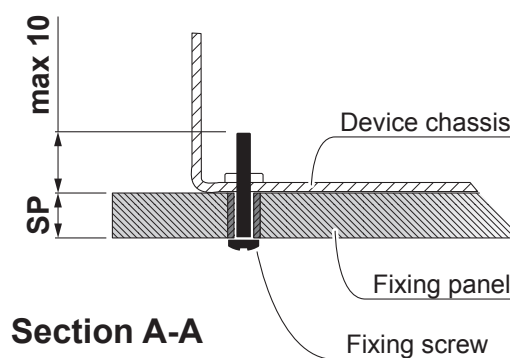

The screw length (L) will be calculated according to the thickness of the panel (Sp) on which the device is fixed, as follows:

$$L \leq 10\text{mm} + Sp$$

For example, if panel thickness is 10mm (Sp = 10mm), the maximum length for screws will be 20mm.

KPM180H (models with presenter)

The device is provided with six fixing holes on the bottom of device (see following figure). To fasten the device on a panel, use six M3 screws.

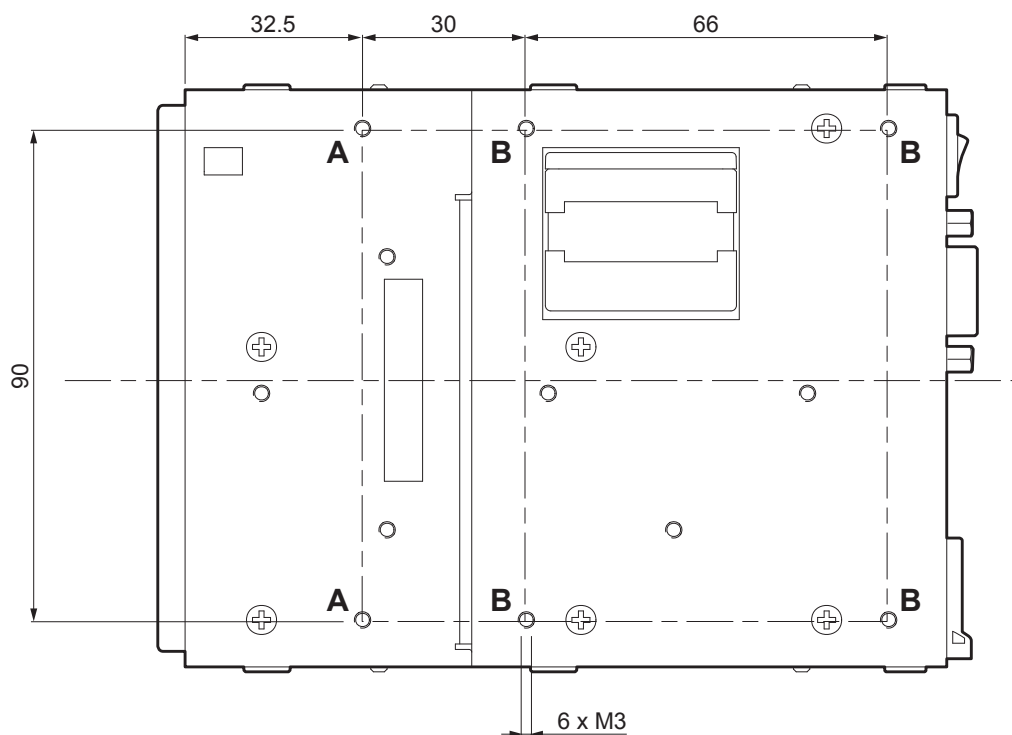

Additionally, the panel must provide an opening for dust of paper that meets the following measures (in millimetres):

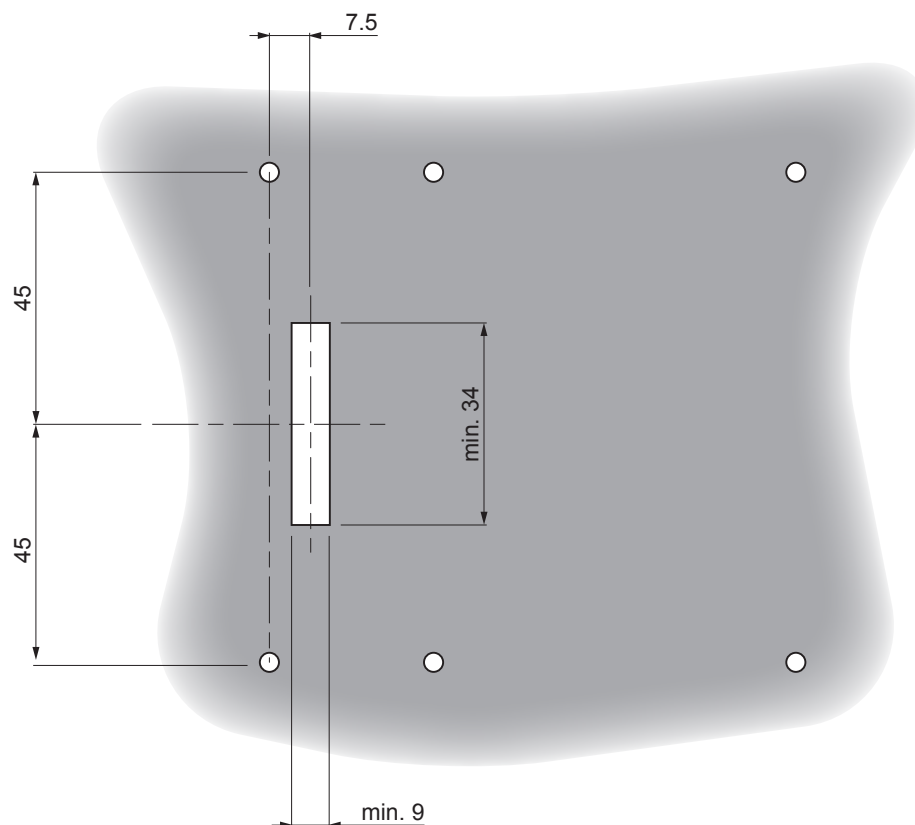

It is very important to consider the screws length not to damage the internal components placed near the fixing holes (see following figure).

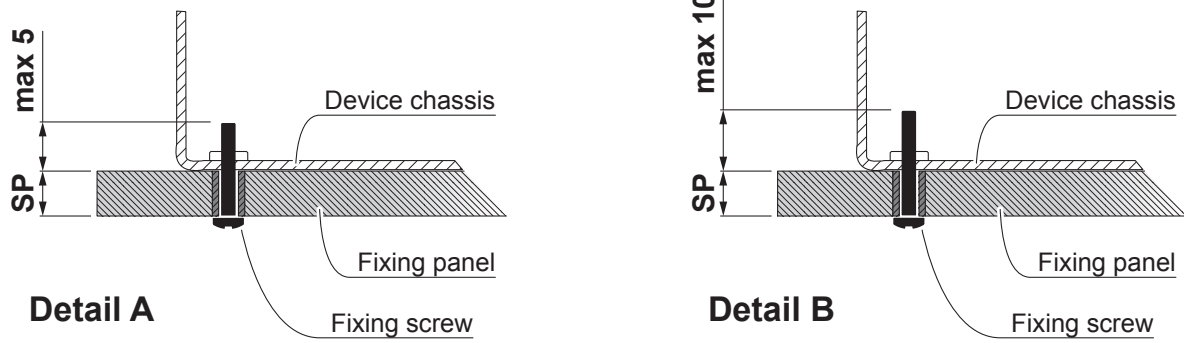

The screw length (L) will be calculated according to the thickness of the panel (Sp) on which the device is fixed, as follows:

$$L \leq 5\text{mm} + Sp \text{ (Detail A)}$$

$$L \leq 10\text{mm} + Sp \text{ (Detail B)}$$

For example, if panel thickness is 10mm (Sp = 10mm), The maximum screw length will be 15mm (detail A) or 20mm (detail B).

TK180 (plastic models)

The device is provided with two slots for the mounting of the machine on a panel.

The slots are placed at the bottom of the machine (see following figure)

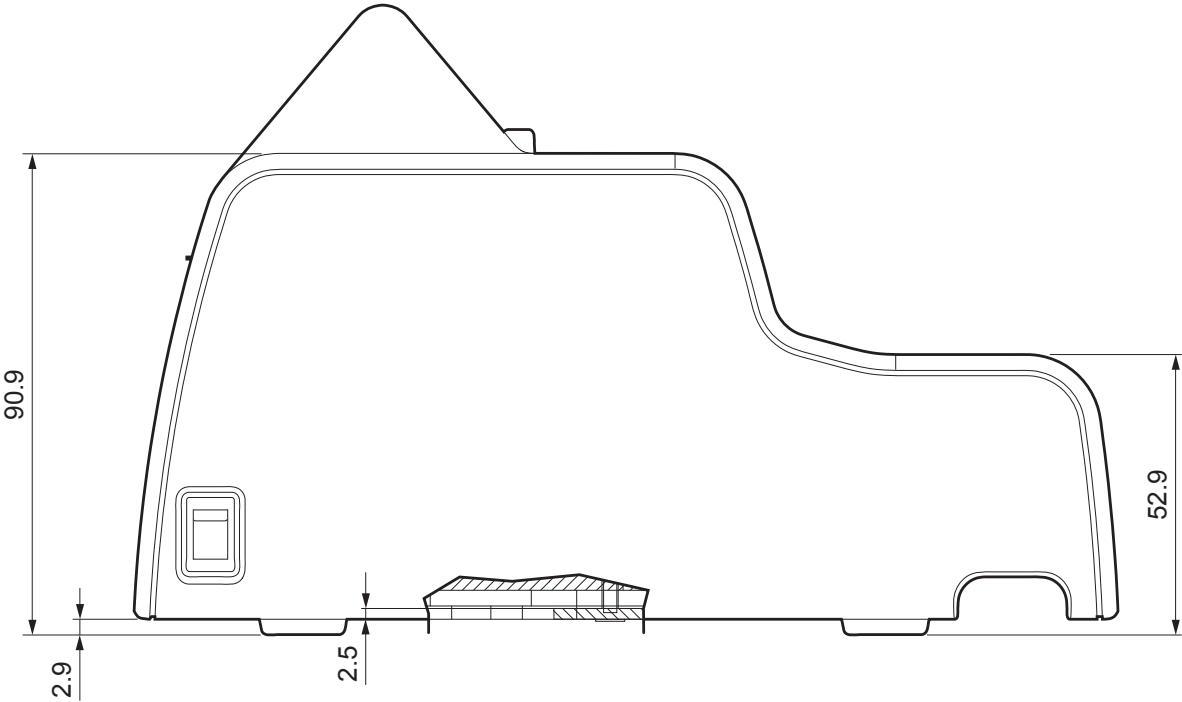
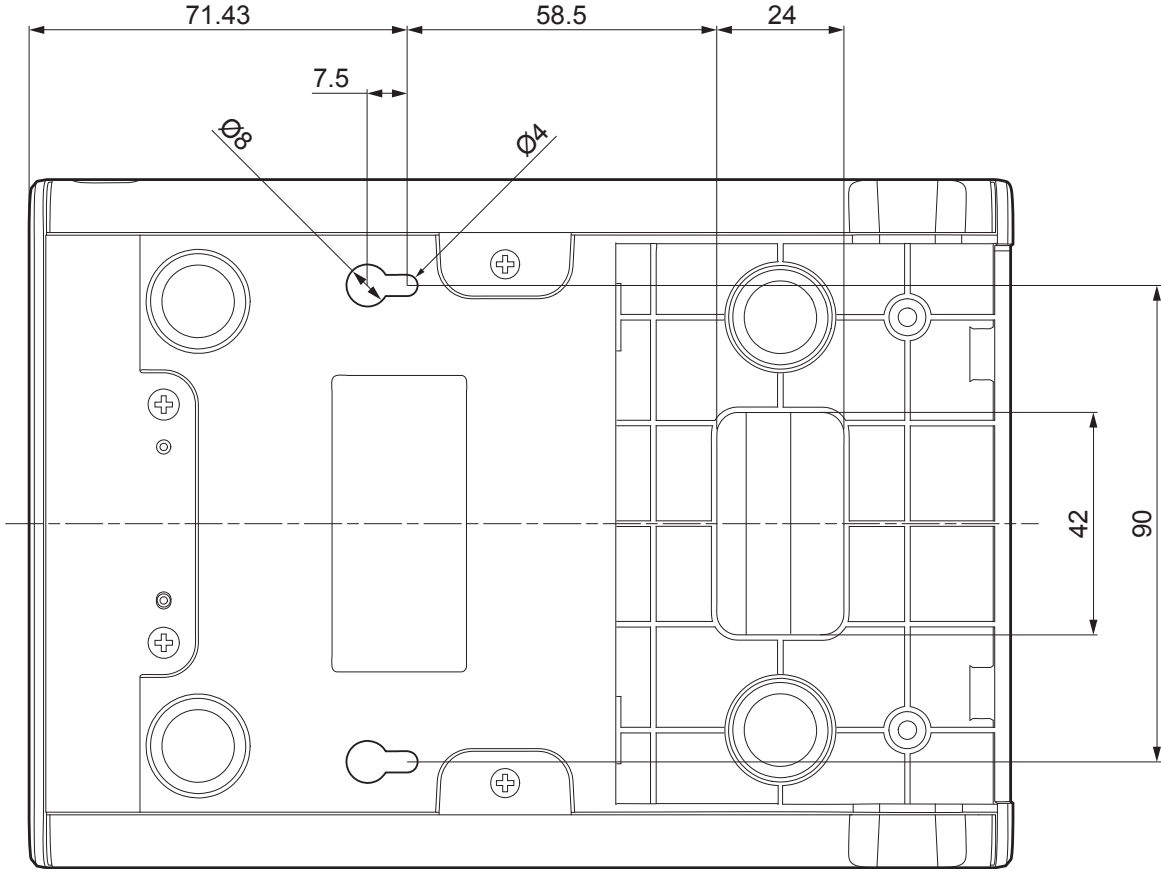

Additionally, the panel can provide an opening for the passage of the connection cables that meets the hole at the bottom of the device. The measures (in millimeters) of the opening are shown in the following figure:

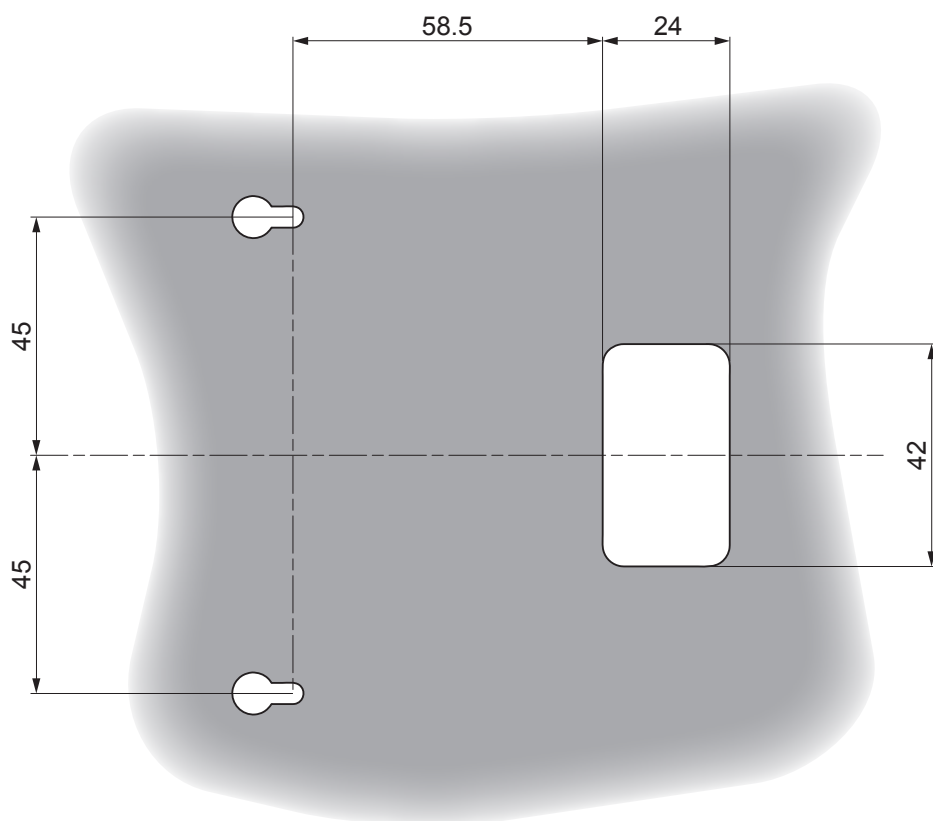

3.2 Near paper end sensor

KPM180H

The device includes a near paper end sensor with the cable (see following figure). To fix the sensor, use an M3 screw not supplied.

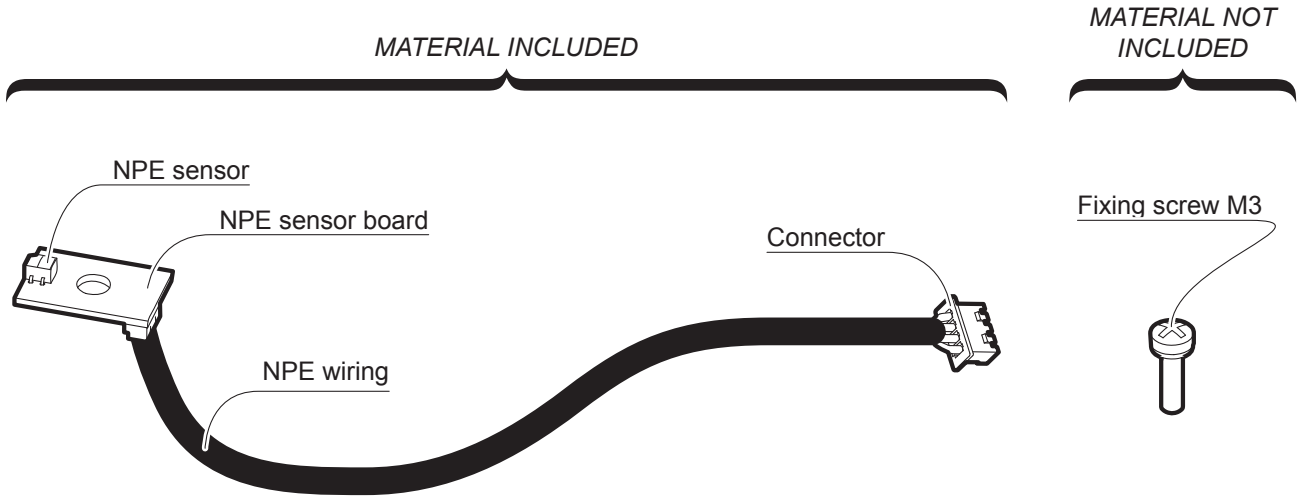

For the assembly procedure, proceed as follows:

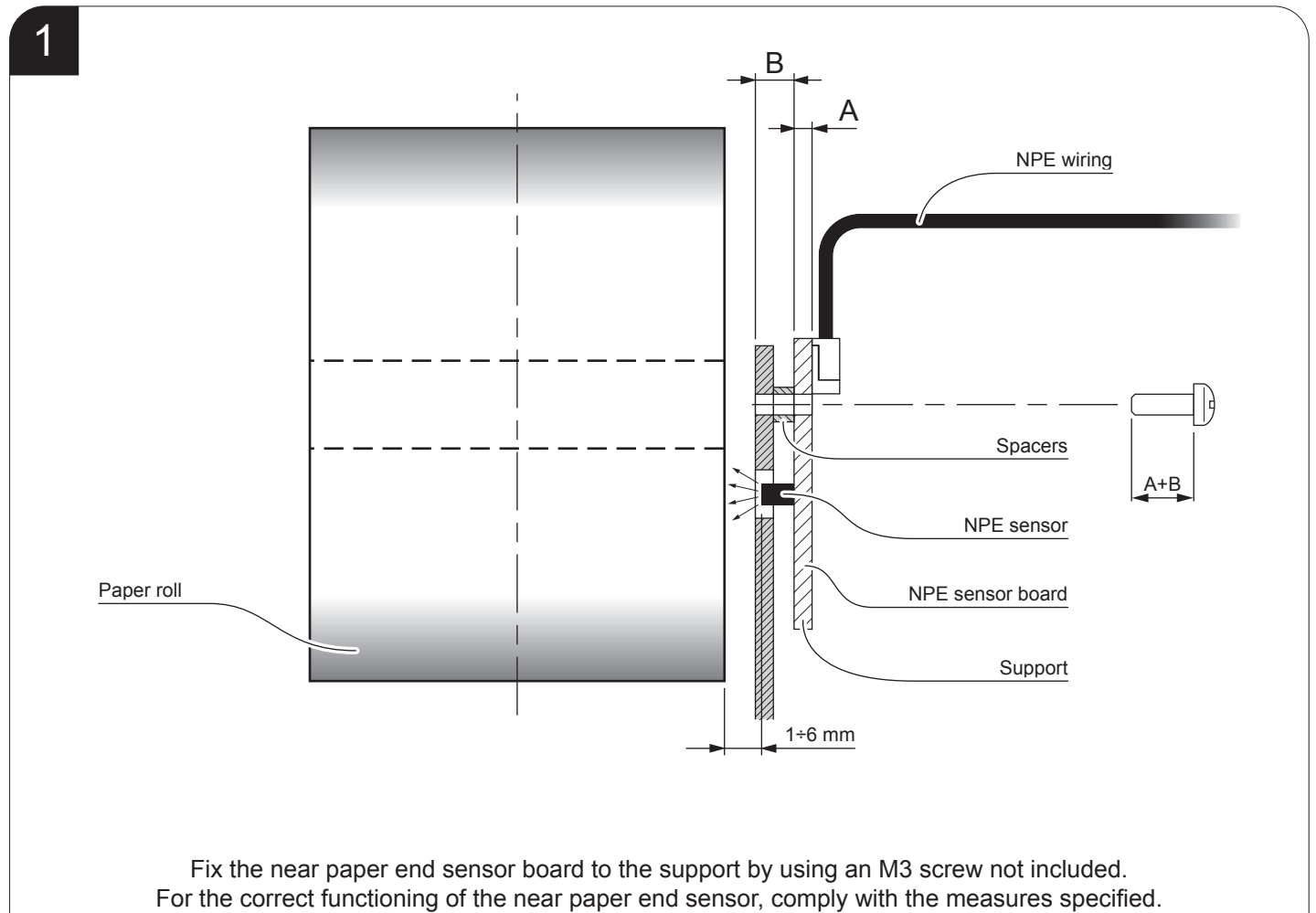

2

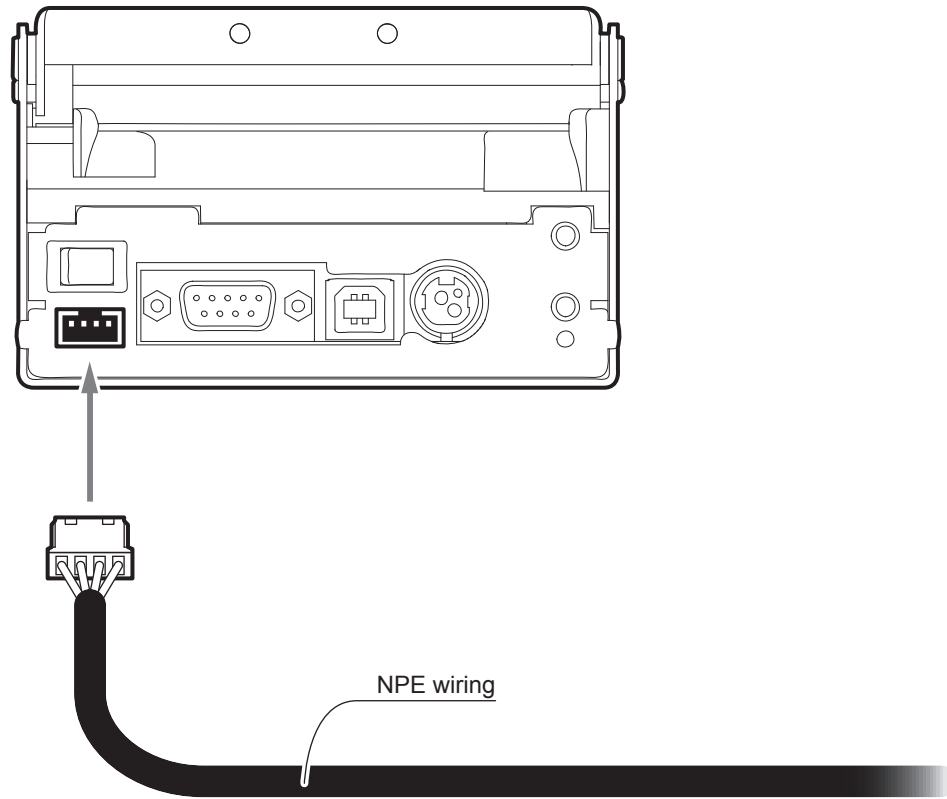

Connect the wiring coming from the near paper end sensor board at the connector shown in figure.

3.3 Connections

The following figure shows the possible connections for the device.

Models without ETHERNET port

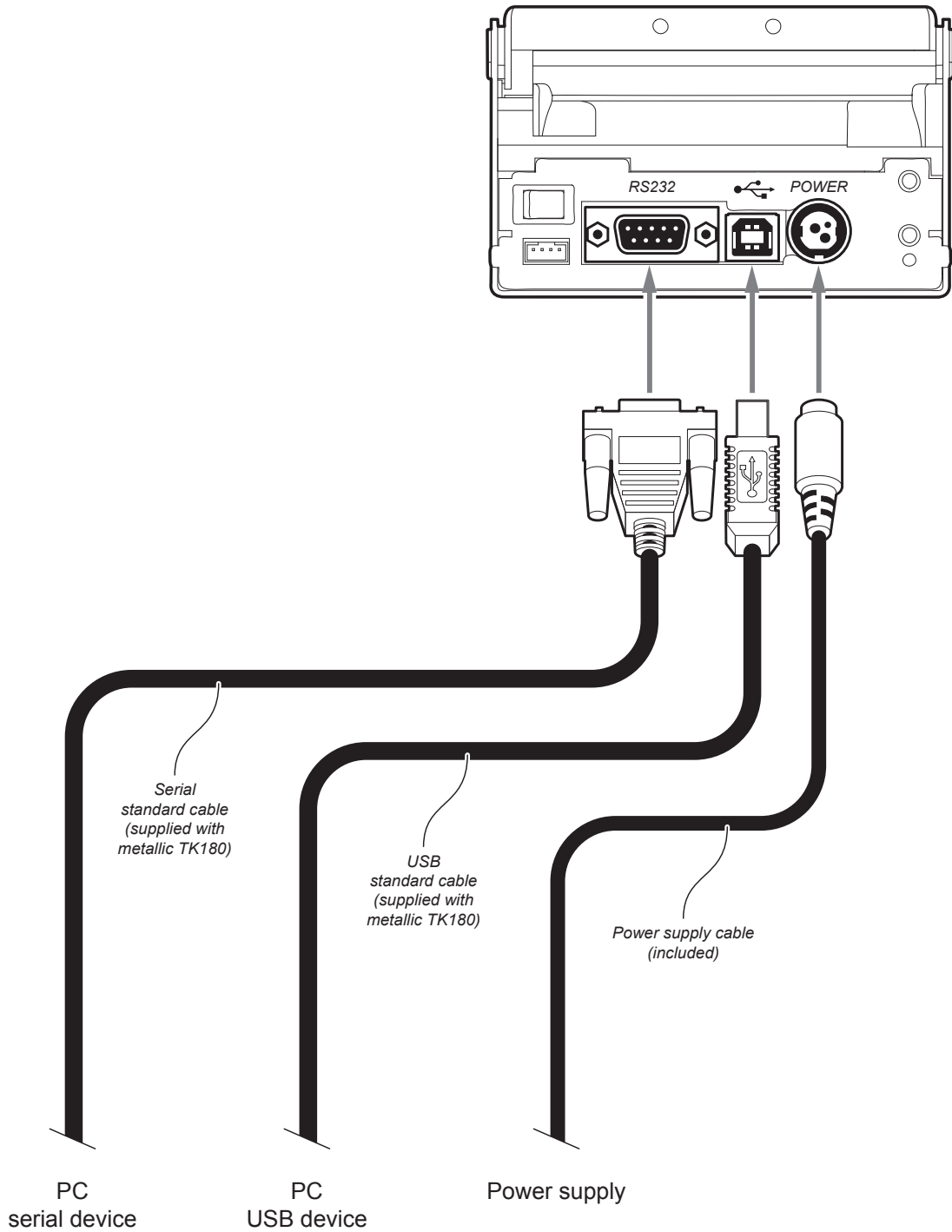

ATTENTION: In some conditions, we recommend the installation of a ferrite core on the power supply cable.

NOTES: If serial and USB connectors are inserted, communication port is USB.

For some models, only the internal printer group is represented.

Models with ETHERNET port

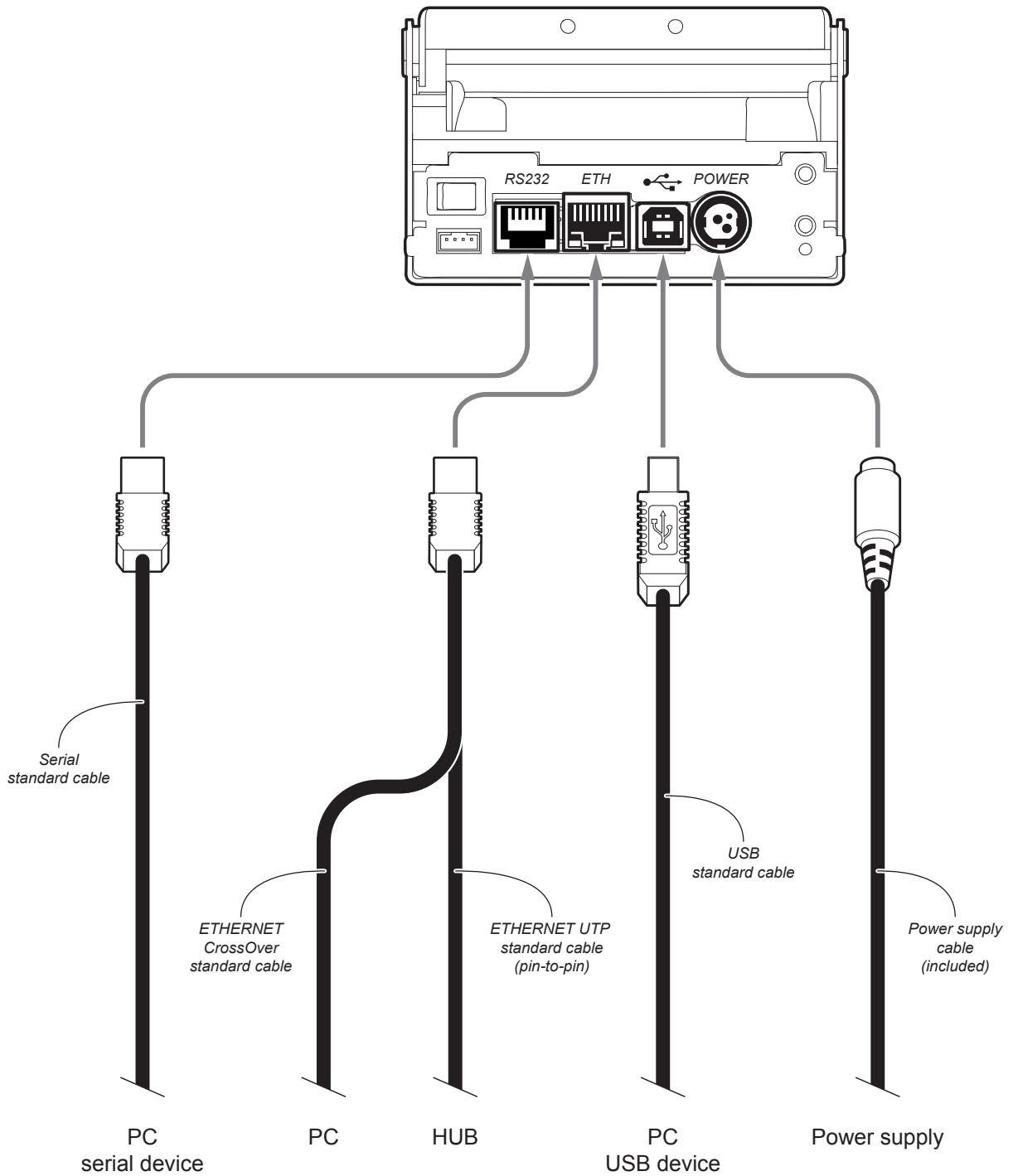

ATTENTION: In some conditions, we recommend the installation of a ferrite core on the power supply cable.

NOTES: If serial and USB connectors are inserted, communication port is USB.

For some models, only the internal printer group is represented.

3.4 Pinout



POWER SUPPLY
Tripolar female connector

J20	1	GND
	2	+24 Vdc
	3	GND
	4	Frame GND

ATTENTION:
Respect power supply polarity.

NOTE:
Power supply cable
The following figure shows the connector pinout of the power supply cable for the device:

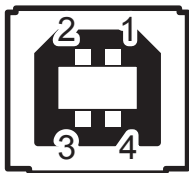
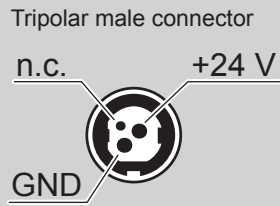
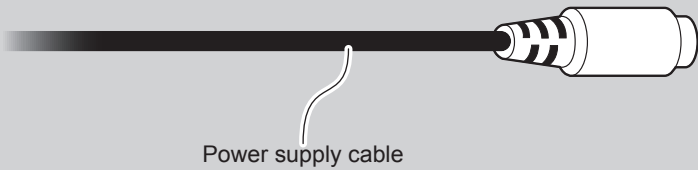

USB INTERFACE
Female USB type B connector

J2	1	USB0-VBUS (in)
	2	USB0_D- (in/out)
	3	USB0_D+ (in/out)
	4	GND
	SH1	SHIELD
	SH2	SHIELD

Models without ETHERNET port

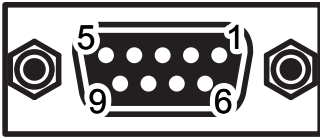

RS232 SERIAL INTERFACE
Female DB9 connector

J1	1	DTR	
	2	TX	During transmission, takes the values "0" and "1" depending on data.
	3	RX	During reception, takes the values "0" and "1" depending on data.
	4	DSR	
	5	GND	
	6	DTR	When "1", device is power on.
	7	CTS	
	8	RTS	When "1", device is ready to receive data
	9	n.c.	

NOTES:

Given the presence of the RS232 standard, logic value "0" corresponds to a voltage level of between +3Vdc and +15Vdc and logic value "1" corresponds to a voltage level of between -3Vdc and -15Vdc.

DEVICE > PC connection

The following picture shows an example of connection between the device and a personal computer using a 9 pin RS232 serial connector:

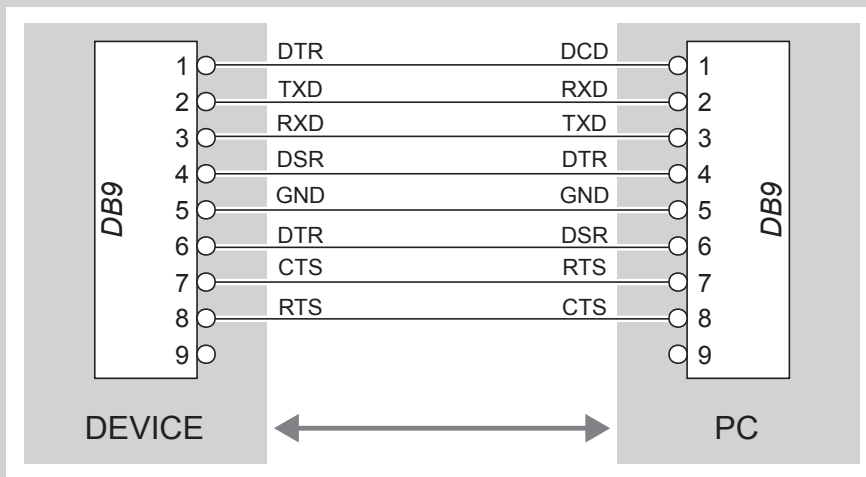

When use a serial cable, we recommend the installation of a ferrite core on the power supply cable.

Models with ETHERNET port

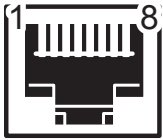

RS232 SERIAL INTERFACE
Female RJ45 connector

J1	1	DTR	
	2	TX	(out) During transmission, takes the values "0" and "1" depending on data
	3	RX	(in) During reception, takes the values "0" and "1" depending on data
	4	DR	
	5	GND	
	6	DT	When "1", device is power on
	7	CT	
	8	RTS	(out) When "1", device is ready to receive data

NOTES:

Given the presence of the RS232 standard, logic value "0" corresponds to a voltage level of between +3Vdc and +15Vdc and logic value "1" corresponds to a voltage level of between -3Vdc and -15Vdc.

DEVICE > PC connection

The following picture shows an example of connection between the device and a personal computer using an 8 pin RJ45 male and a 9 pin RS232 serial connector:

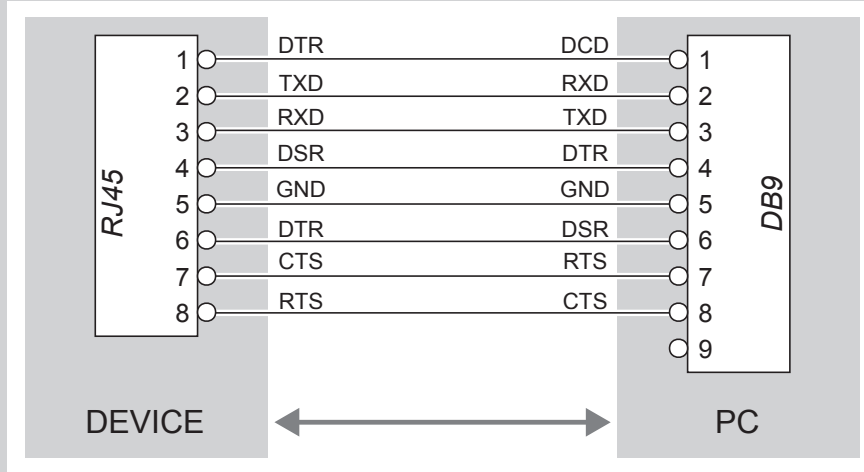

When use a serial cable, we recommend the installation of a ferrite core on the power supply cable.

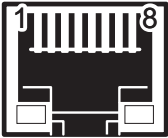

ETHERNET INTERFACE

Female RJ45 connector

J23	1	RX +1
	2	+3.3V ETH
	3	RX -1
	4	TX +1
	5	+3.3V ETH
	6	TX -1
	7	n.c
	8	GND
	9	+3.3 V
	10	LED-LNK
	11	+3.3 V
	12	LED-LAN
	13	Shield
	14	Shield

NOTES:

The functionality of two LED are specified in the following tables:

- For 10Base-T connection:

LED	FUNCTION
LED-LNK	Link (yellow color): the LED lights up when a connection is active
LED-LAN	Rx/Tx: (green color): the LED lights up when occurs a data reception or transmission

- For 10/100Base-TX connection:

LED	FUNCTION
LED-LNK	The LED light (yellow color) on when a connection is active and flashes when occurs a data reception or transmission
LED-LAN	The LED light (green color) on when occurs a 100Mbit connection and off when occurs a 10Mbit connection

The device automatically recognizes the type of connection (cross or pin-to-pin).

The pinout shown in table represents the input signals to component J23 before the isolation voltage transformer (through-hole pin).

3.5 Driver and SDK

The drivers are available for the following operating system:

OPERATING SYSTEM	DESCRIPTION	INSTALLATION PROCEDURE
Windows	Driver for Windows XP	From the START menu, press Run and type-in the path where the SW was saved on your PC, then click OK. Follow the instructions that appear on the screen to install the driver.
	Driver for Windows VISTA (32/64bit)	
	Driver for Windows 7 (32/64bit)	
	Driver for Windows 8 (32/64bit)	
Linux	(32/64bit)	Follow the instruction get back on the README.TXT file. You can find it in the software package downloaded in advance.
Android	SDK for CustomAndroidAPI	Extract the zipped folder to the destination path desired. Follow the instructions present in the software package that you downloaded on how to install and use the SDK
iOS	SDK for CustomiOSApi	Extract the zipped folder to the destination path desired. Follow the instructions present in the software package that you downloaded on how to install and use the SDK

NOTE:

All drivers can be found in the DOWNLOAD section of the web site www.custom.biz.

4 OPERATION

4.1 Opening cover

KPM180H

1

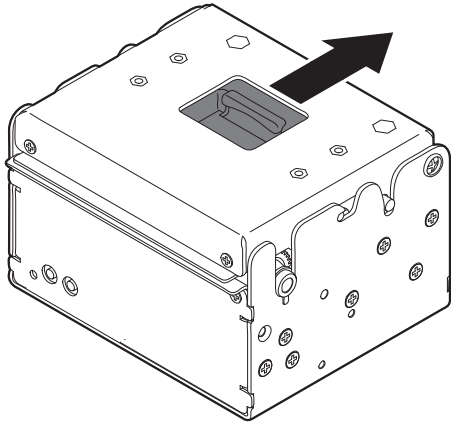

Push the release lever in the direction shown in the figure.

2

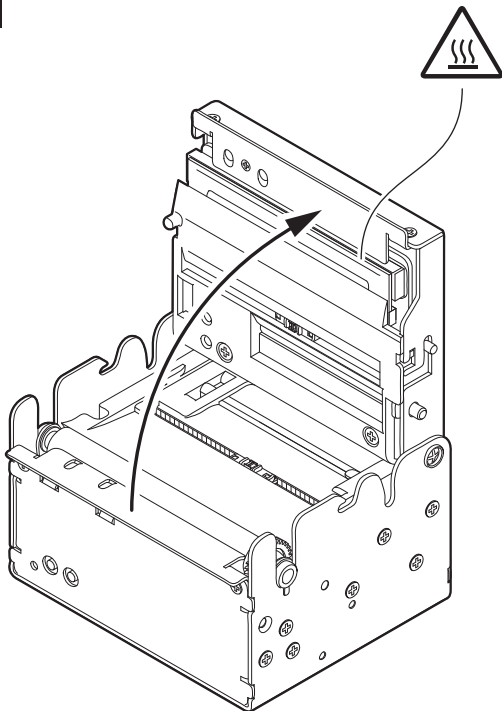

Open the device cover.

TK180 (plastic models)

1

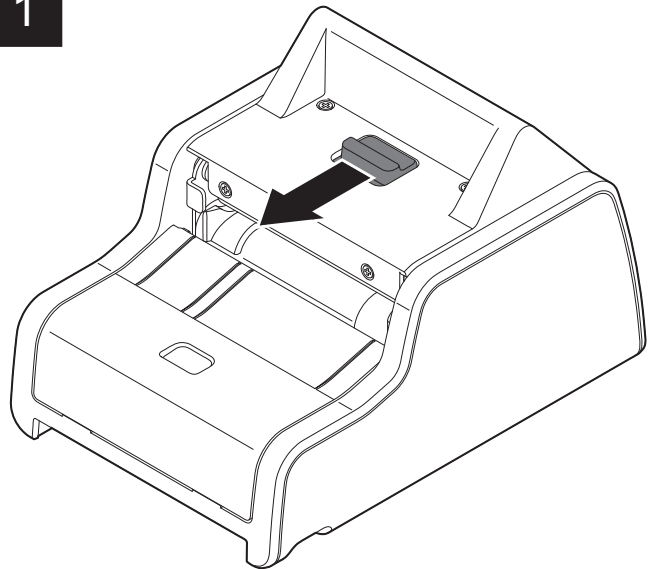

Push the release lever in the direction shown in the figure.

2

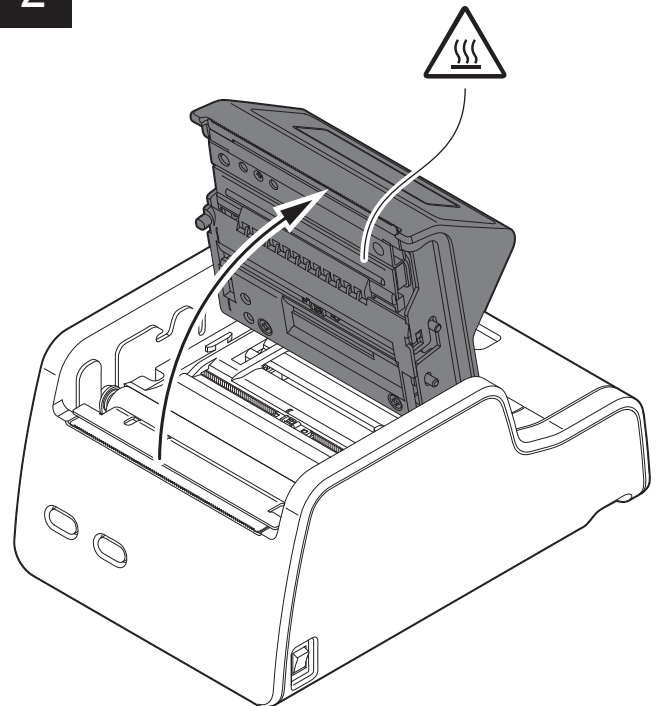

Open the device cover.

TK180 (metallic models)

1

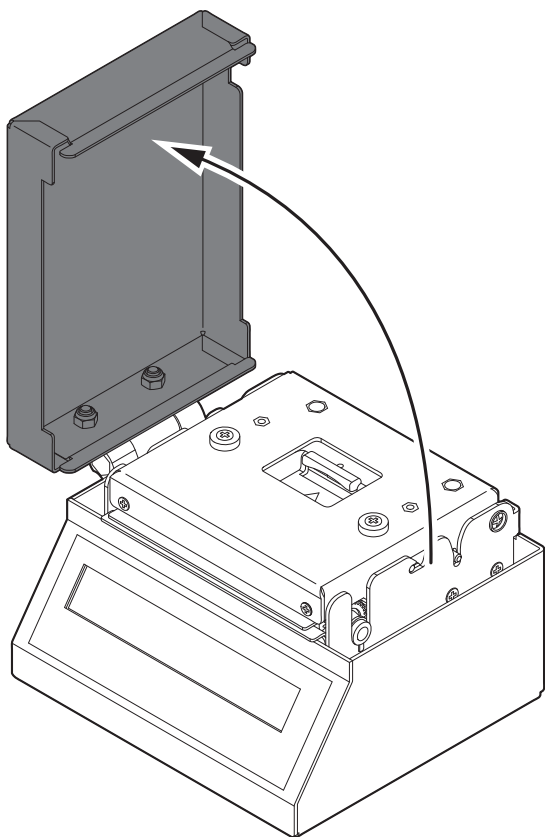

Open the metallic cover.

2

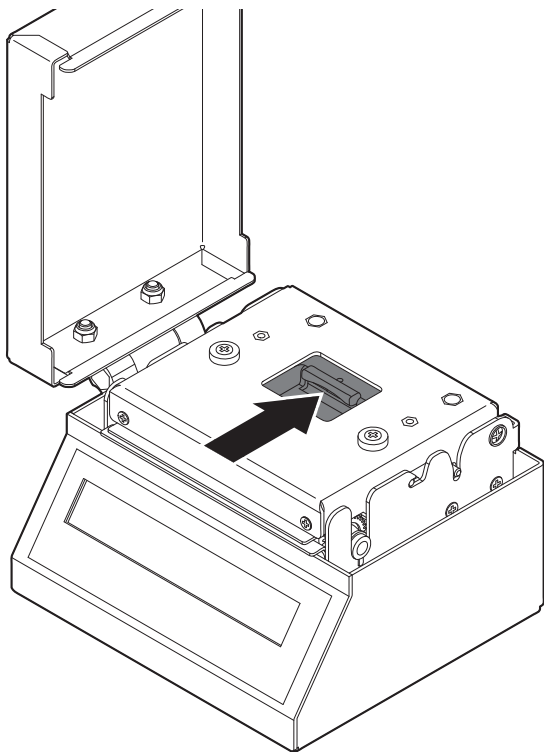

Push the opening lever shown in figure.

3

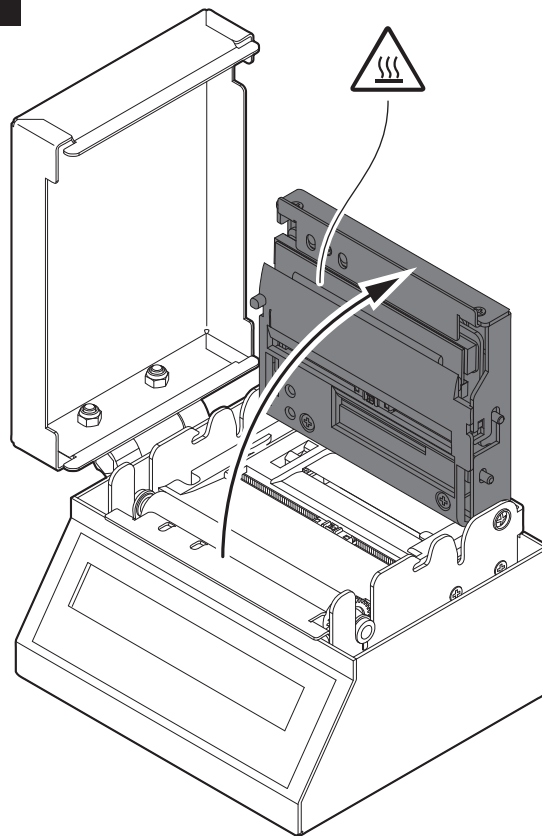

Open the device cover.

4.2 Adjusting paper width

Paper width may be adjusted from 25 mm to 82.5 mm by moving the adjustable cursor as shown in the following figure.

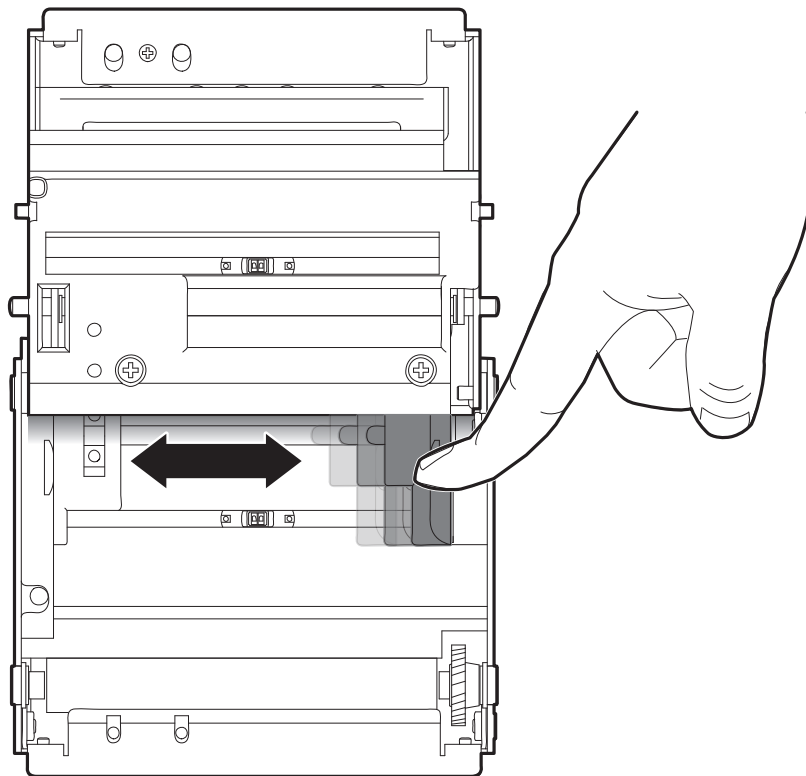

To manage paper width from 20 mm to 25 mm, apply the spacer on the mobile paper guide (see following figure), then adjust the paper width.

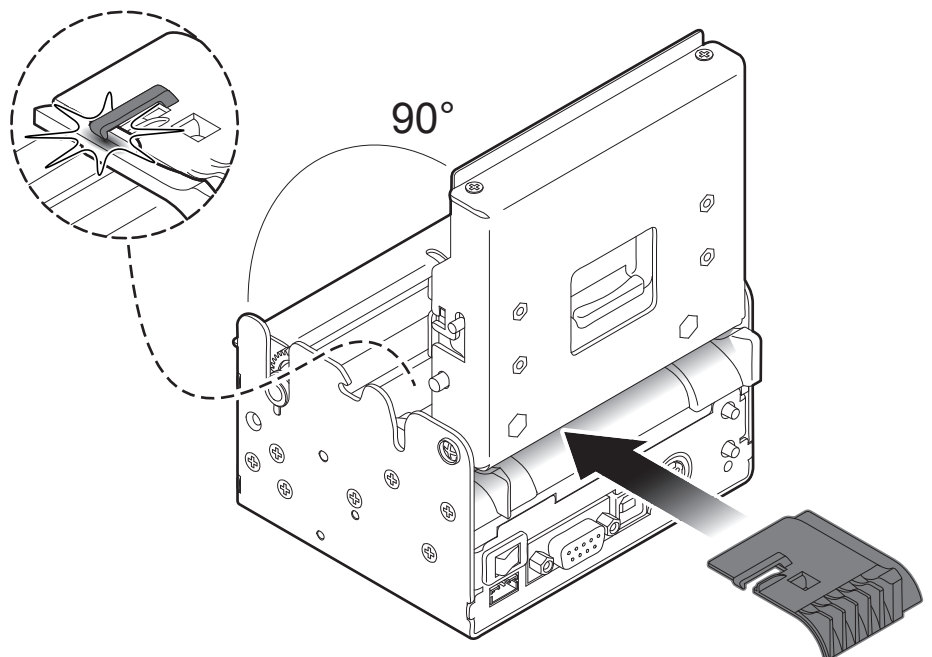

NOTE: For some models, only the internal printer group is represented.

4.3 Adjusting the alignment sensors

The device is equipped with two mobile sensors for the detection of the alignment black mark placed both on the thermal side and on the non-thermal side of paper as shown in the following figure.

The user will need to manually move these mobile sensors according to the position and the type of the black mark on the paper (see next paragraphs).

To use these sensors, you must set the "Notch/B.Mark Position" setup parameter on the correct value (see Chapter 5).

NOTE: For some models, only the internal printer group is represented.

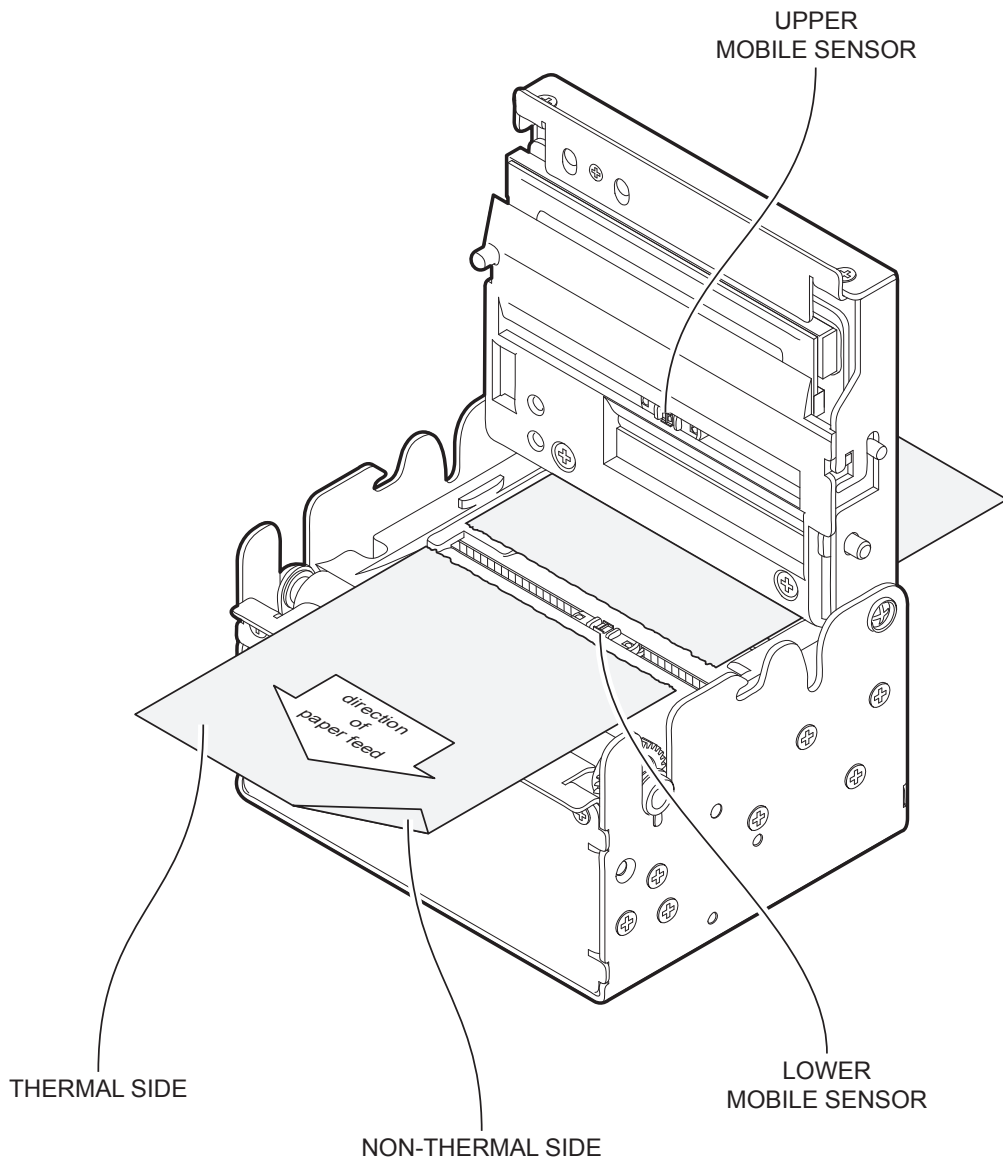

To adjust the mobile sensors position according to the black mark position and type on paper, open the device cover (see par.4.1) and move the sensors to the desired position using a small screwdriver or a pointed object.

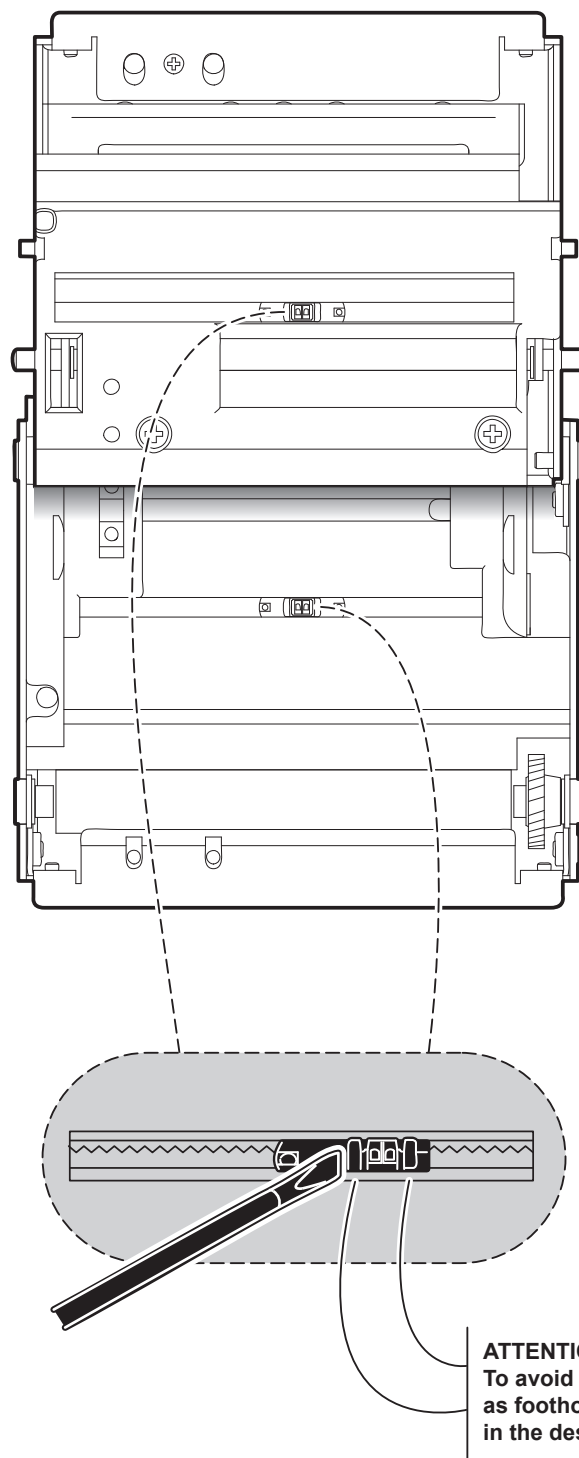

4.4 Switch the device ON

KPM180H

1

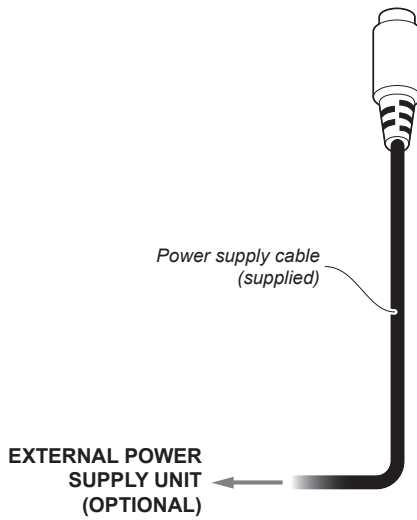

Connect the power supply cable to an external power supply unit.

2

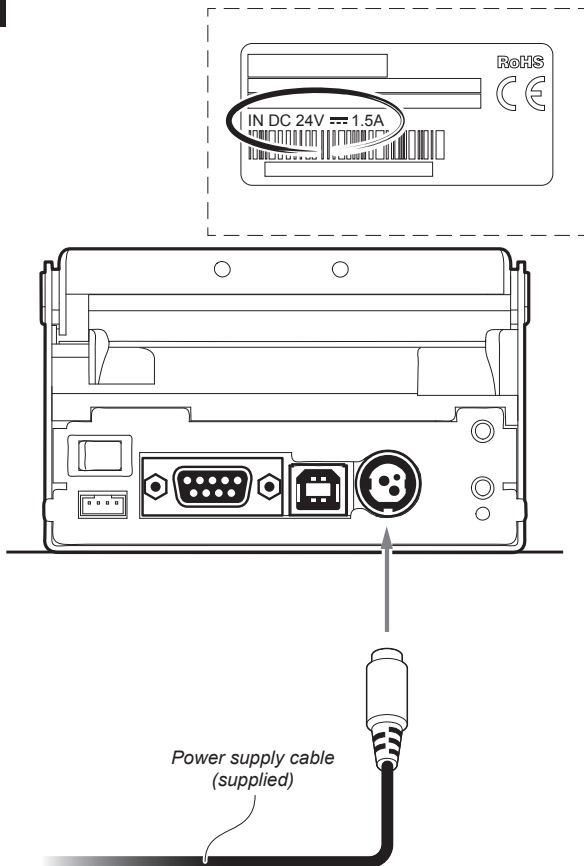

Connect the power supply cable to the device. Use the type of electrical power supply indicated on the label.

3

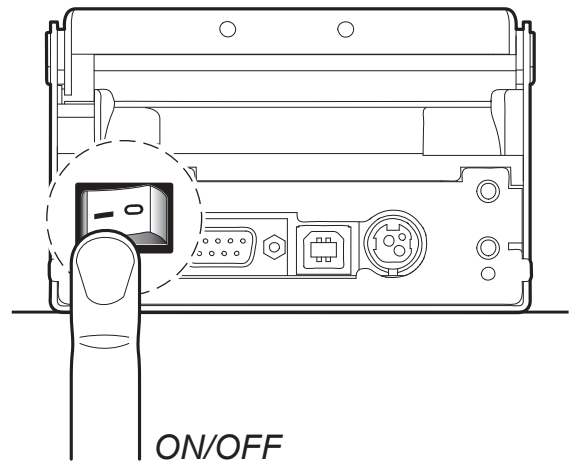

Switch device On pressing the ON/OFF key.

4

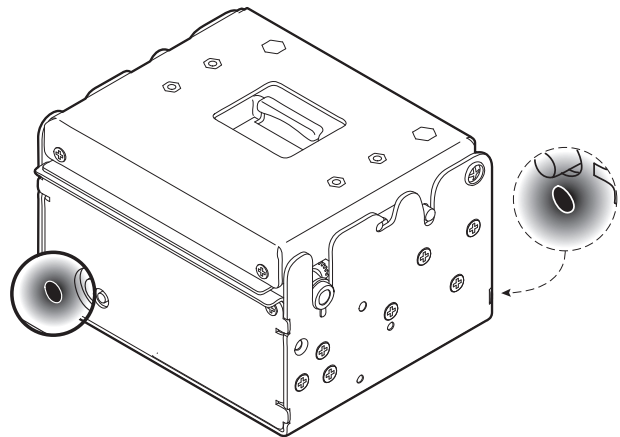

The green leds (front and rear) turn on and the device is ready.

TK180 (metallic models)

1

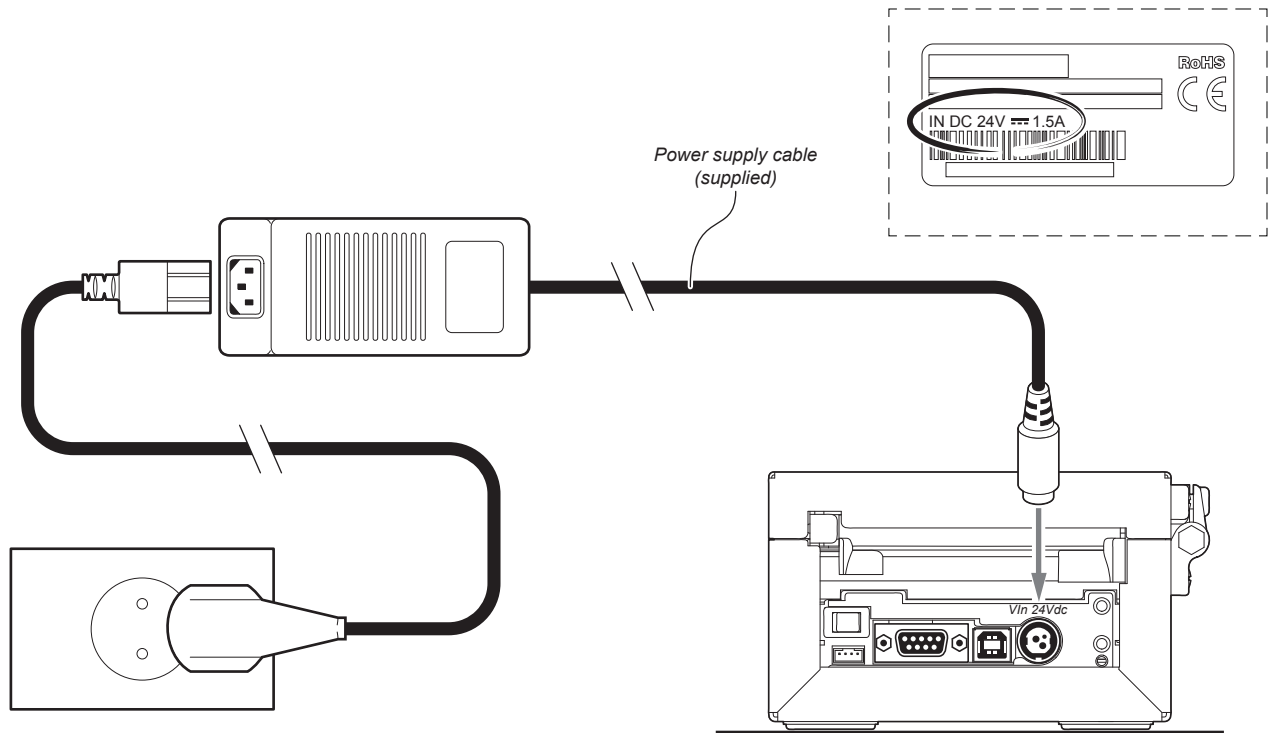

Connect the power adapter (supplied) to the device and the mains outlet.
Use the type of electrical power supply indicated on the label.

2

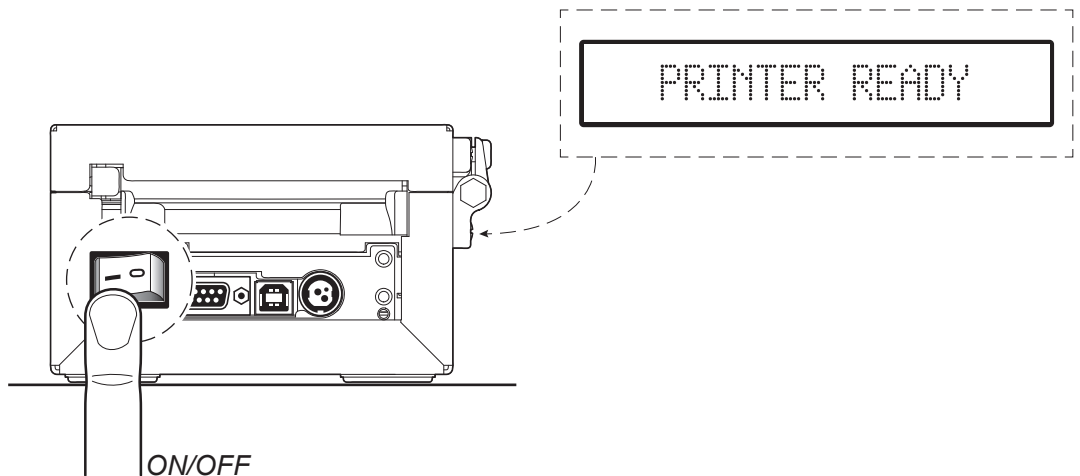

Switch device on pressing the ON/OFF key.
The display turns on and shows the message in figure.

TK180 (plastic models)

1

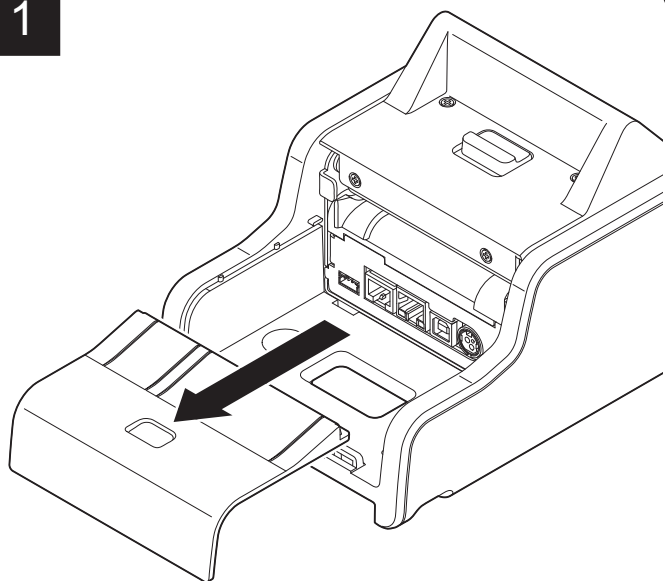

Remove the connector cover by sliding it in the direction shown.

2

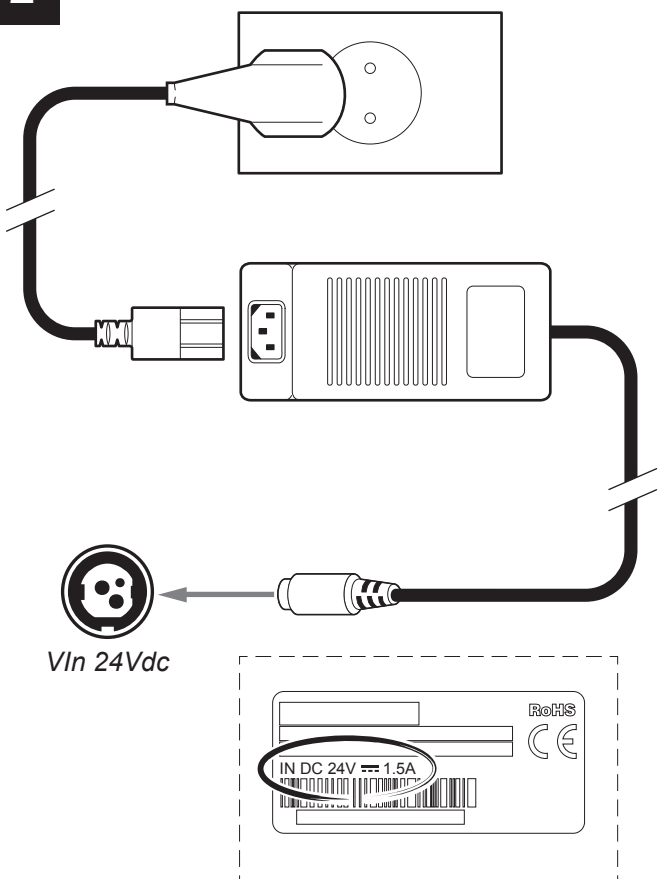

Connect the power adapter (supplied) to the device and the mains outlet. Use the type of electrical power supply indicated on the label.

3

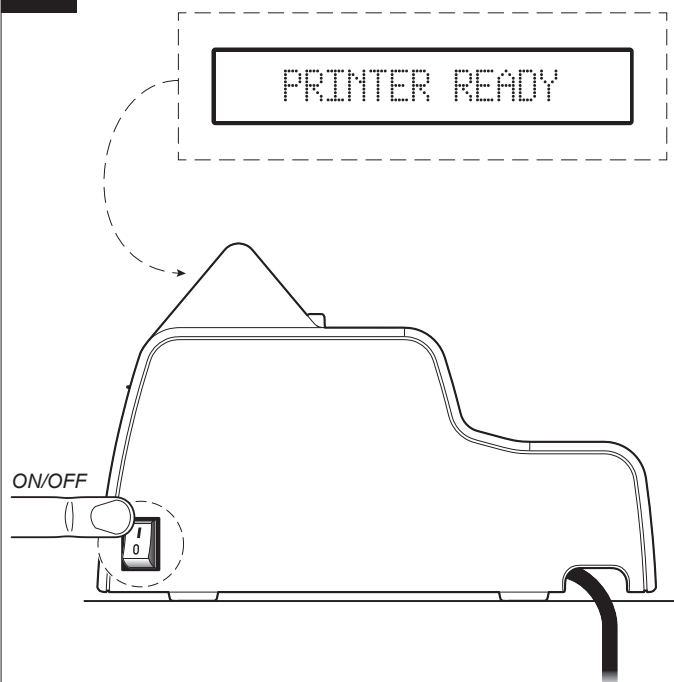

Switch device on pressing the ON/OFF key. The display turns on and shows the message in figure.

4.5 Loading the paper roll

To change the paper proceed as follows. At every change of paper, check inside the device to locate and remove any scraps of paper.

NOTE: For some models, only the internal printer group is represented.

1

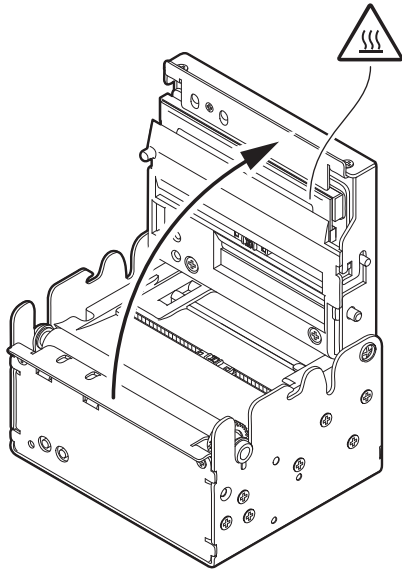

Open the device cover
(see previous paragraphs).

2

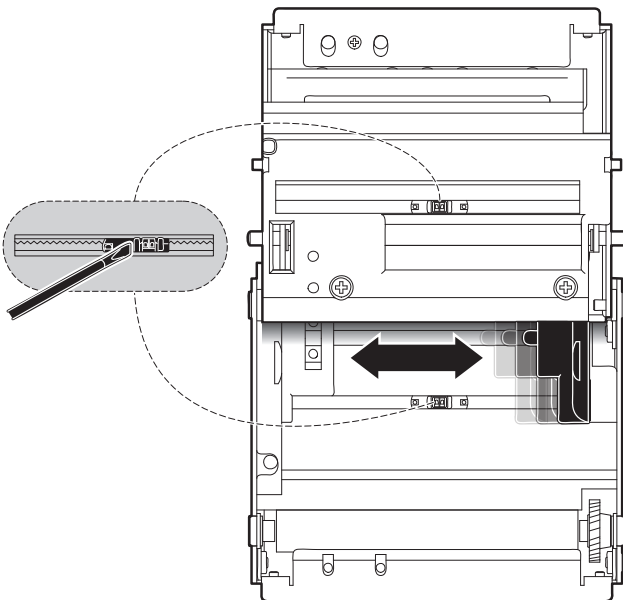

Adjust the paper width and the notch sensors
position (see previous paragraphs).

3

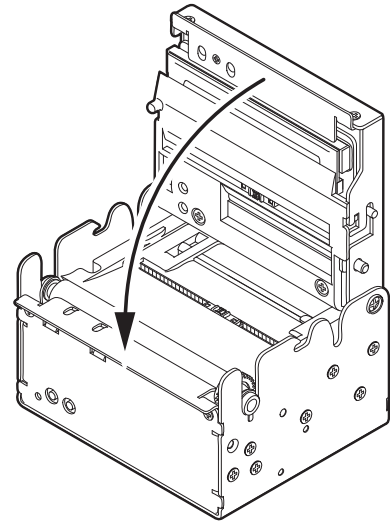

Close the
device cover.

4

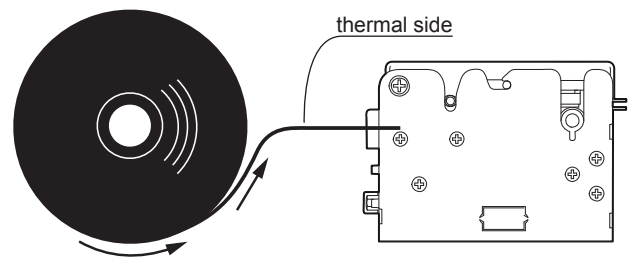
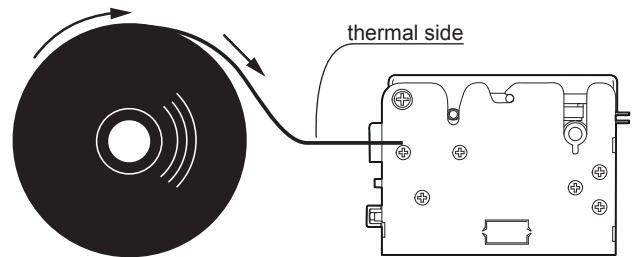

Insert the paper into the input mouth so that it unrolls
correctly. Be sure that the paper is
correctly positioned into paper guides.

6

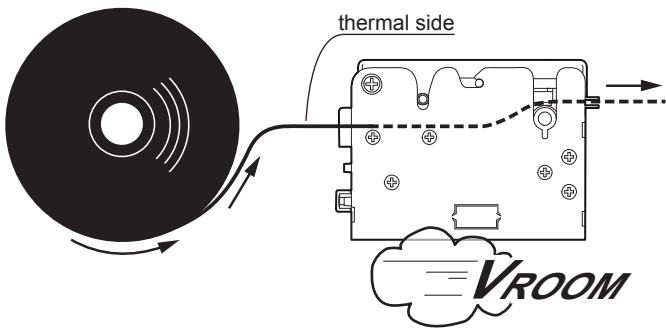
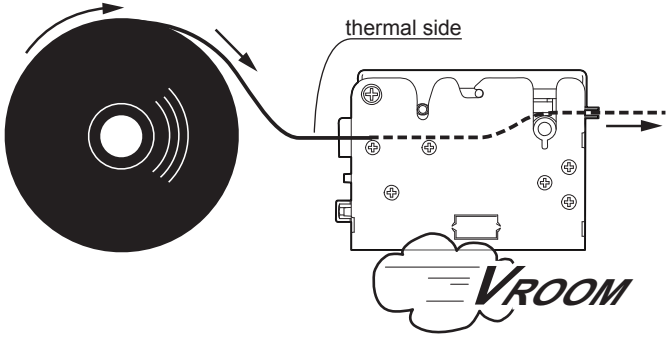

Wait until the paper is automatically loaded.

The following figure gives the limit positions of the paper roll related to the device for a correct paper loading without a paper roll holder support.

The direction of the paper will always form a maximum angle of 90° or -90° with the insertion plane of paper inside the device.

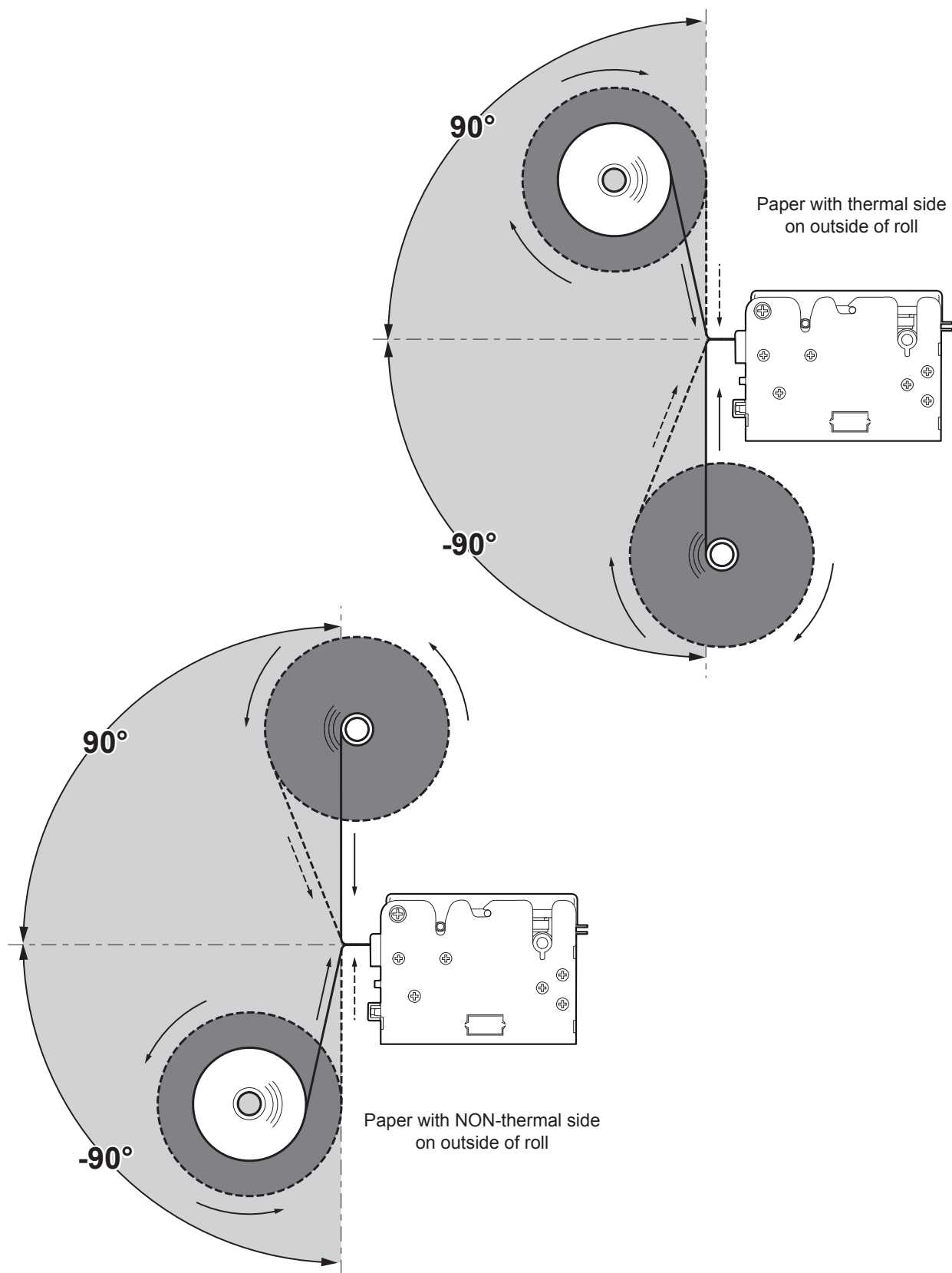

NOTE: For some models, only the internal printer group is represented.

4.6 Issuing ticket (models with presenter)

The device allows you to choose between different operating modes for the issuance of printed tickets. The operating modes shown in the following images, depend on the settings of the configuration parameters and commands sent to the device.

“EJECT” mode

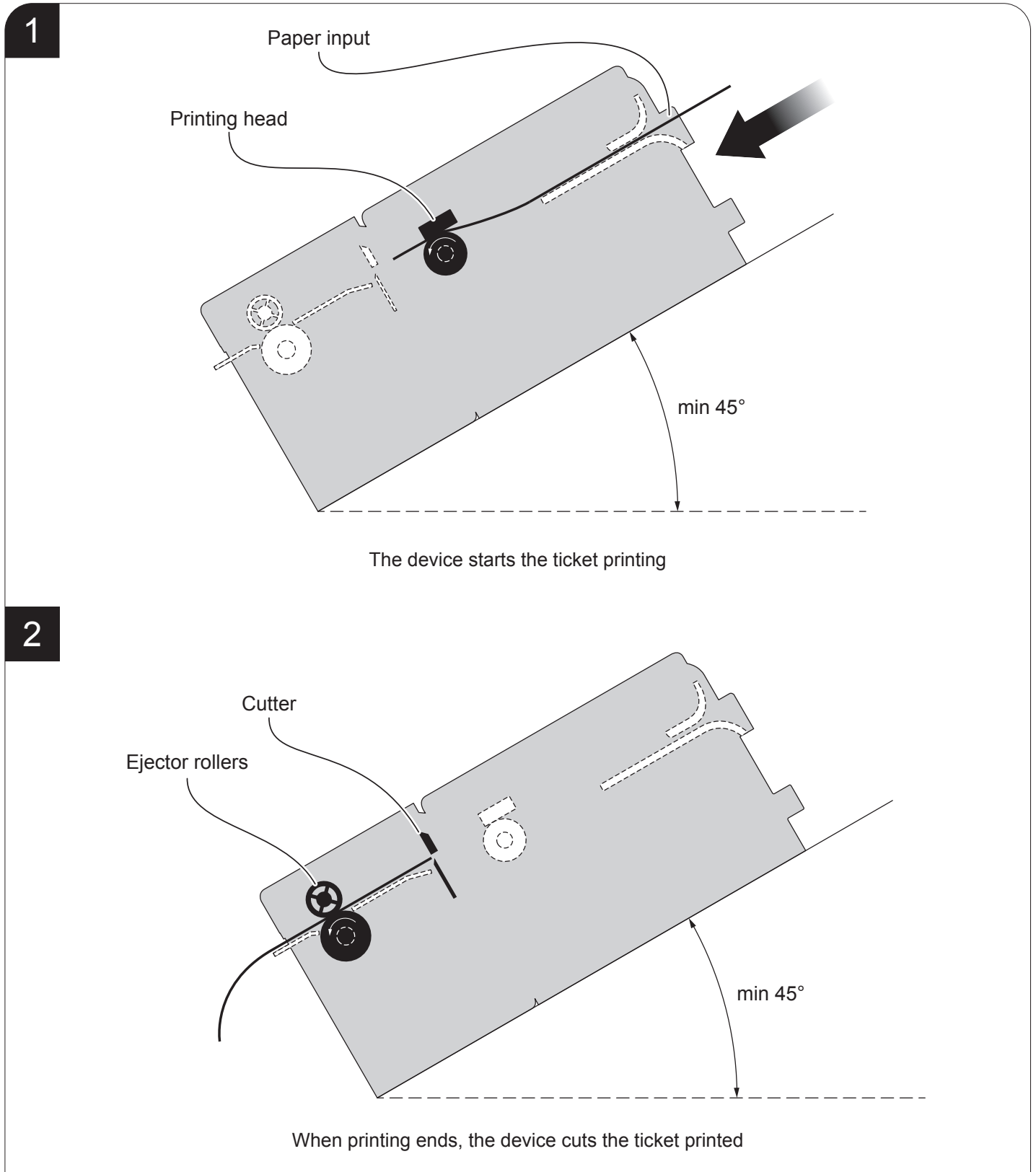

3

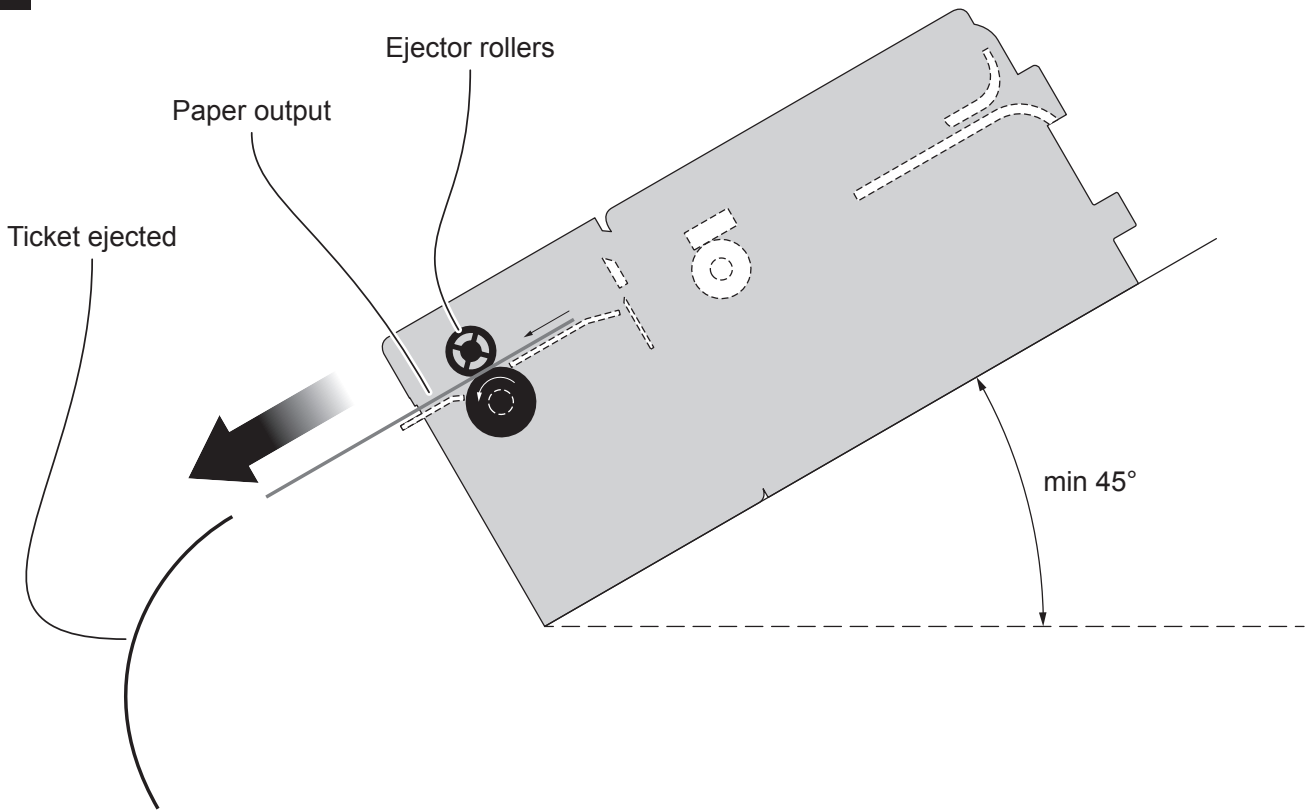

The device directly ejects the ticket

1

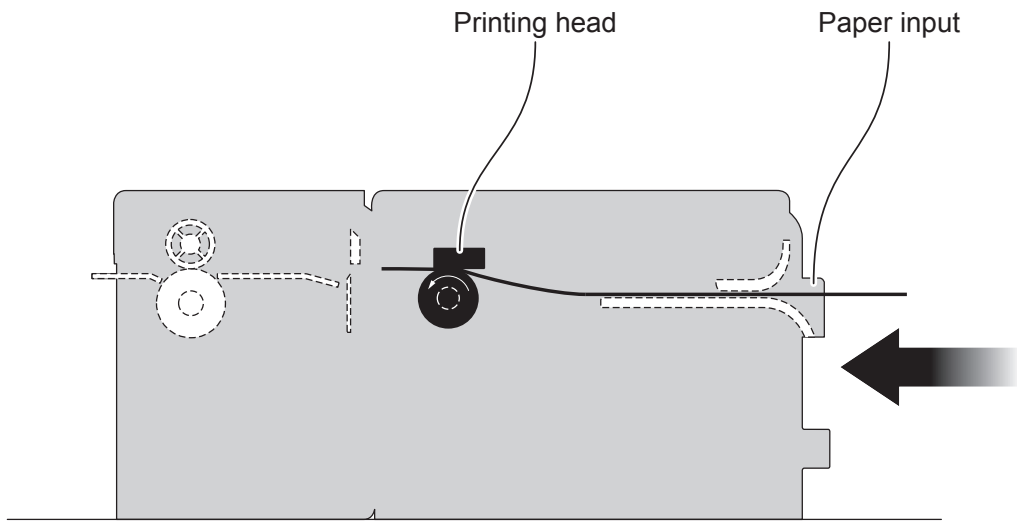

The device starts the ticket printing

2

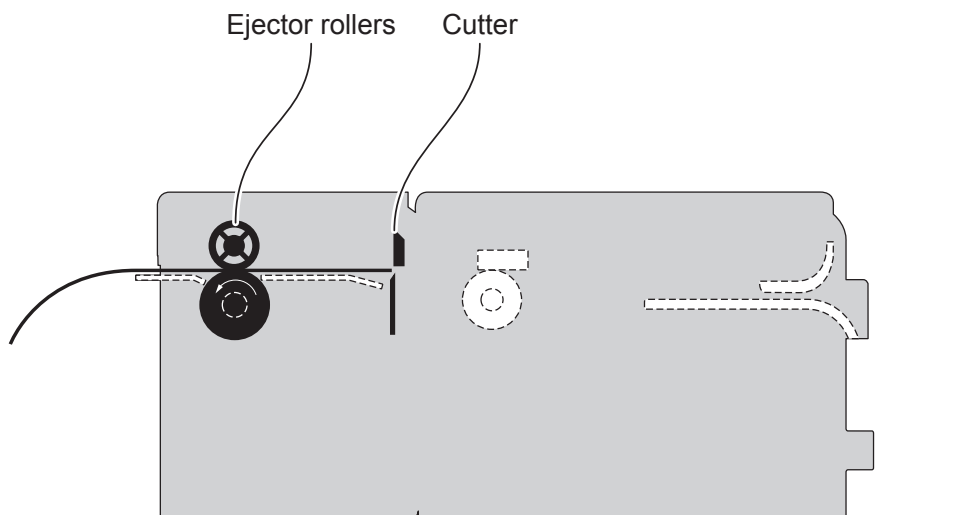

When printing ends, the device cuts the ticket printed

3

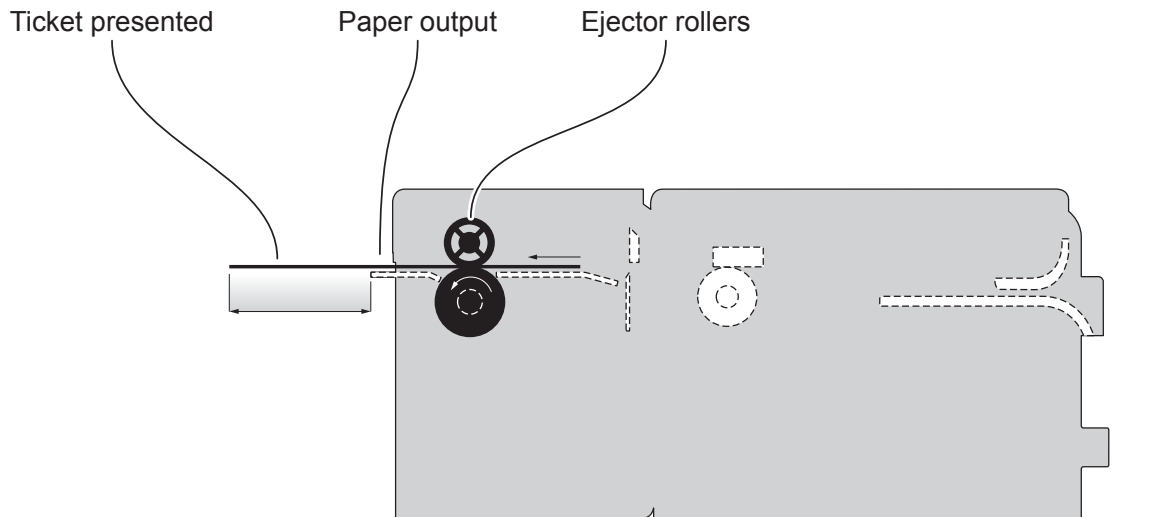

The device presents a portion of the ticket printed on the paper mouth

4

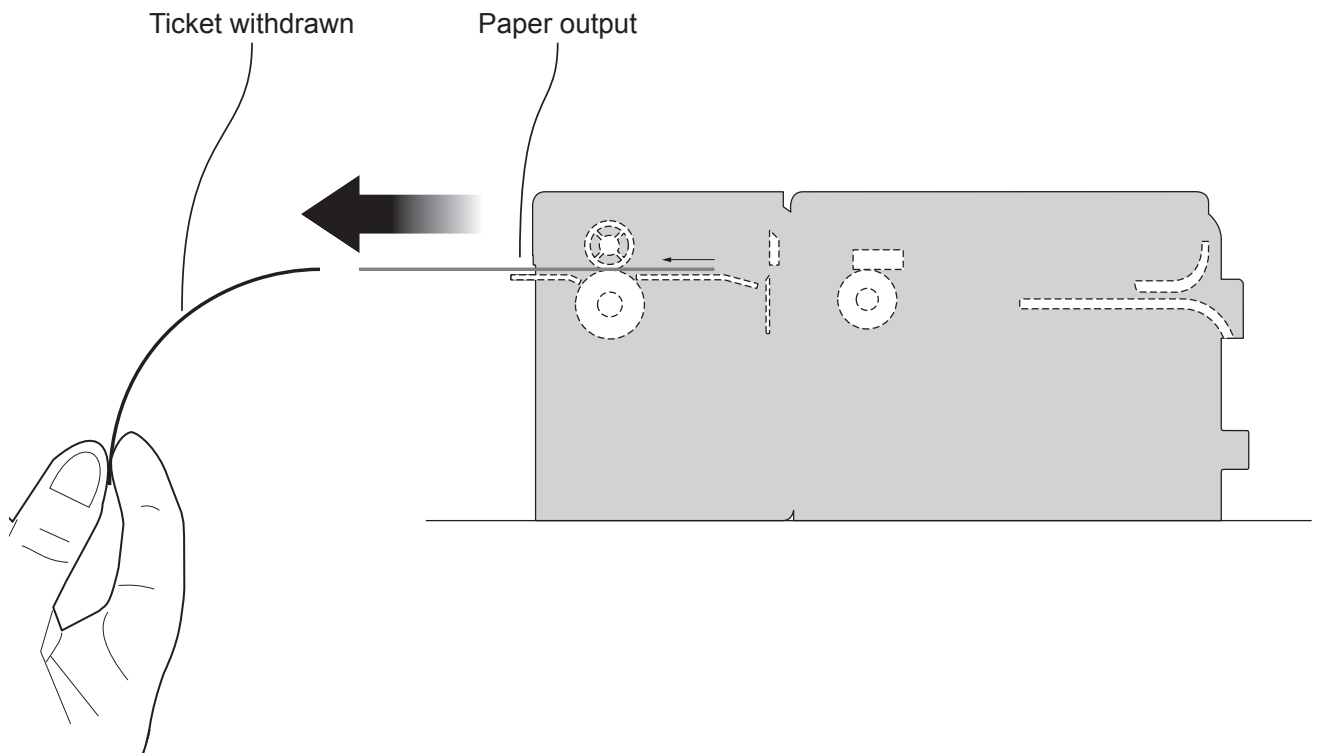

The user withdraws the ticket from the paper mouth

5 CONFIGURATION

5.1 Configuration mode

To enter the configuration mode and print a SETUP report with the operating parameters of the device, proceed as follows.

1

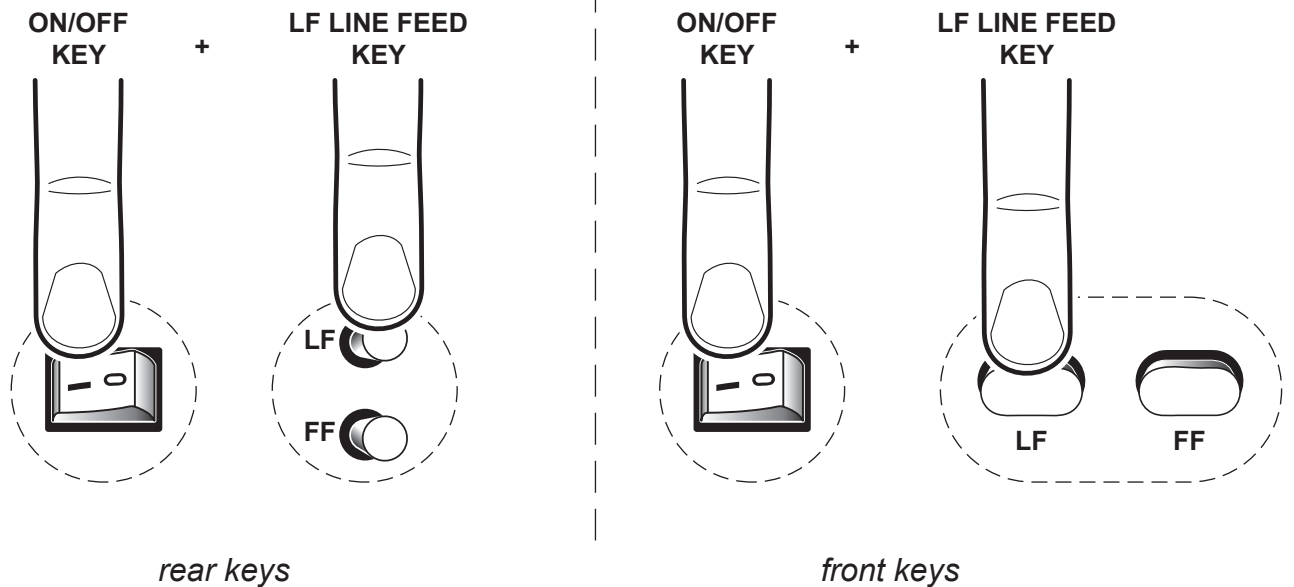

While pressing the LF LINE FEED key, switch on the device by pressing the ON/OFF key.

2



The device prints the report with the settings parameters. Follow the instruction printed on the paper or shown on display to proceed with configuration procedure.

5.2 Setup report

The following figure shows the setup report of the device. The shown values for parameters are sample values; for the list and the description of device parameters see the following paragraphs.

<p><i>DEVICE NAME and FIRMWARE MODULES RELEASE</i></p>	}	<p style="text-align: center;"><i><device name></i></p> <p>SCODE. <i><code></i> - rel 1.00 DCODE. <i><code></i> - rel 1.00 FCODE. <i><code></i> - rel 1.00</p>
<p><i>PRINTING HEAD STATUS</i></p>	}	<p>PRINTER SETTINGS</p> <p>1 «.....» 640</p> <hr style="border-top: 1px dashed black;"/> <p>PRINthead WORKING GOOD!</p>
<p><i>DEVICE STATUS</i></p>	}	<p>PRINTER TYPE<i><device model></i> PRINTING HEAD TYPE<i><head model></i> INTERFACERS232 PROGRAM MEMORY TEST.....OK DYNAMIC RAM TEST.....OK EXTERNAL MEMORY TESTOK CUTTER TEST.....OK HEAD VOLTAGE [V] = 23,37 HEAD TEMPERATURE [°C] = 25 POWER ON COUNTER = 4 PAPER PRINTED [cm] = 40 CUT COUNTER = 1</p>
<p><i>PRINTER PARAMETERS</i></p>	}	<p>Printer Emulation : CUSTOM/POS RS232 Baud Rate : 115200 bps RS232 Data Length : 8 bits/chr RS232 Parity : None RS232 Handshaking : Hardware Busy Condition : RxFull USB Mass Storage : Disabled USB Address Number : 0 USB Virtual COM..... : Disabled Print Mode : Normal Autofeed : CR Disabled Code Table [num] : 0 Chinese Font : Disabled Chars / inch : A=15 B=20 cpi Speed / Quality..... : Normal Print Width : 80 mm Paper Threshold : 40% Notch/B.Mark Position : Bottom Notch/B.Mark Threshold : 40% Notch Distance [mm] : +00.0 Notch/B.Mark Min.Width..... : 0 mm Ticket Locking..... : Disabled Ticket Management : Disabled PrintHead Test PowerOn : Disabled Casing Type..... : Plastic Print Density : 0%</p>
<p><i>KEYS FUNCTIONS</i></p>	}	<p>[LF] <i>enter Setup</i> [FF] <i>skip Setup</i></p>

Models with ETHERNET port

The following figure shows the setup report of the ETHERNET parameters. The shown values for parameters are sample values; for the list and the description of device parameters see the following paragraphs.

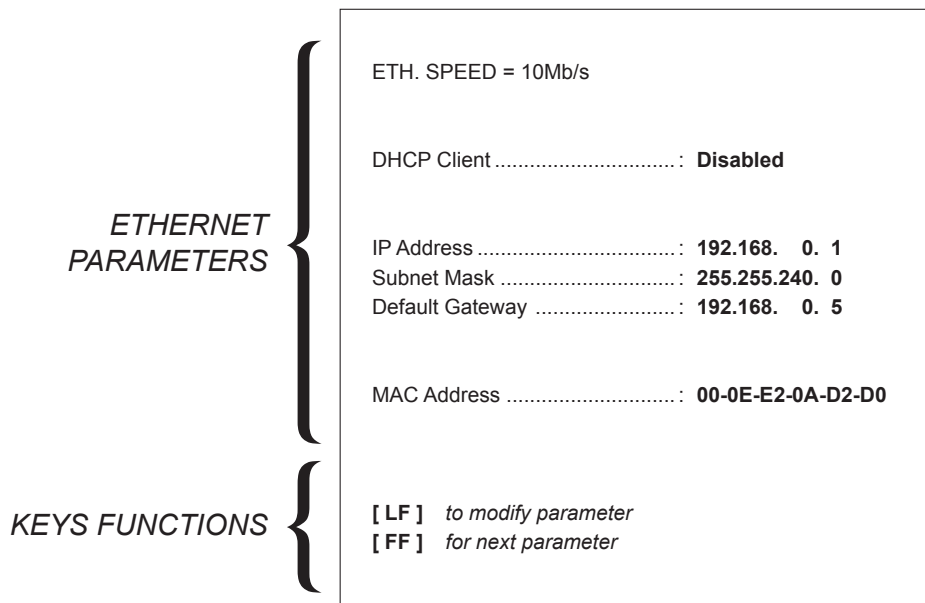

5.3 Device status

The device operating status is indicated in the configuration print-out in which, next to the name of the components displayed, the following information is given:

PRINTER TYPE	<i>device model</i>
PRINTING HEAD TYPE	<i>print head model</i>
INTERFACE	<i>interface present</i>
PROGRAM MEMORY TEST	<i>OK appears if functioning and NOT OK if faulty</i>
DYNAMIC RAM TEST	<i>OK appears if functioning and NOT OK if faulty</i>
EXTERNAL MEMORY TEST	<i>OK appears if functioning and NOT OK if faulty</i>
CUTTER TEST *	<i>OK appears if functioning and NOT OK if faulty</i>
HEAD VOLTAGE	<i>voltage of the head</i>
HEAD TEMPERATURE	<i>temperature of the head</i>
POWER ON COUNTER	<i>number of power-ups made</i>
PAPER PRINTED	<i>centimetres of paper printed</i>
CUT COUNTER *	<i>number of cuts made</i>

NOTE:

* : Only for KPM180H with presenter.

5.4 Printer parameters

The device allows the configuration of the parameters listed in the following table. The parameters marked with the symbol ^D are the default values. Settings remain active even after the device has been turned off and they are stored in non-volatile memory.

PRINTER EMULATION	<p><i>Available emulations for the device:</i></p> <p>SVELTA CUSTOM/POS ^D</p>
RS232 BAUD RATE	<p><i>Communication speed of the serial interface:</i></p> <p>115200 ^D 9600 57600 4800 38400 2400 19200 1200</p> <p>NOTE: Parameter valid only with serial interface.</p>
RS232 DATA LENGTH	<p><i>Number of bit used for characters encoding:</i></p> <p>7 bits/car 8 bits/car ^D</p> <p>NOTE: Parameter valid only with serial interface.</p>
RS232 PARITY	<p><i>Bit for the parity control of the serial interface:</i></p> <p>None ^D = parity bit omitted Even = even value for parity bit Odd = odd value for parity bit</p> <p>NOTE: Parameter valid only with serial interface.</p>
RS232 HANDSHAKING	<p><i>Handshaking:</i></p> <p>XON/XOFF = software handshaking Hardware ^D = hardware handshaking (CTS/RTS)</p> <p>NOTES: Parameter valid only with serial interface.</p> <p>When the receive buffer is full, if handshaking is set to XON/XOFF, the device sends the XOFF (0x13) on the serial port. When the receive buffer has cleared once again, if handshaking is set to XON/XOFF, the device sends the XON (0x11) on the serial port.</p>
BUSY CONDITION	<p><i>Activation mode for Busy signal:</i></p> <p>OffLine/ RXFull = Busy signal is activated when the device is both in OffLine status and the buffer is full RXFull ^D = Busy signal is activated when the buffer is full</p> <p>NOTE: Parameter valid only with serial interface.</p>

USB MASS STORAGE

Sharing mode from Mass Storage:

Disabled^D = sharing mode disabled

Enabled = sharing mode enabled

USB ADDRESS NUMBER

Numerical address code for the univocal identification of the USB device (in case of more than a USB device connected with the same PC):

<i>0^D</i>	<i>2</i>	<i>4</i>	<i>6</i>	<i>8</i>
<i>1</i>	<i>3</i>	<i>5</i>	<i>7</i>	<i>9</i>

USB VIRTUAL COM

Setting the USB port as a virtual serial port:

Disabled^D = Virtual COM disabled

Enabled = Virtual COM enabled

NOTE: To use this configuration it is necessary to install an additional driver.

PRINT MODE

Printing mode:

Normal^D = enables printing in normal writing way

Reverse = enables printing rotated 180 degrees

AUTOFEED

Setting of the Carriage Return character:

CR disabled^D = Carriage Return disabled

CR enabled = Carriage Return enabled

NOTE: The parameter is printed only with CUSTOM/POS emulation enabled.

CODE TABLE [num]

Identifier number of the character code table to use.

The numeric value of the identifier is made up with the following two parameters for the setting of two digits for the tens and the units:

Setting the digit for tens:

CODE TABLE [num x 10]

<i>0^D</i>	<i>2</i>	<i>4</i>
<i>1</i>	<i>3</i>	<i>5</i>

Setting the digit for units:

CODE TABLE [num x 1]

<i>0^D</i>	<i>2</i>	<i>4</i>	<i>6</i>	<i>8</i>
<i>1</i>	<i>3</i>	<i>5</i>	<i>7</i>	<i>9</i>

NOTE:

See the par.7.8 to learn about the character tables corresponding to the identification numbers set with this parameter.

The character tables set with this parameter are the same set with the command 0x1B 0x74 (refer to the Commands Manual of the device).

CHINESE FONT

Setting of the Chinese font:

Disabled^D = Disables the use of the Chinese extended font GB18030-2000

Enabled = Enables the use of the Chinese extended font GB18030-2000

NOTE: When the Chinese font is enabled, the selection of the character code table is suspended (parameter "CODE TABLE"). When the Chinese fonts is disabled, it returns the character code table previously in use (parameter "CODE TABLE").

CHARS / INCH

Font selection:

A = 11 cpi, B = 15 cpi

A = 15 cpi, B = 20 cpi^D

A = 20 cpi, B = 15 cpi

NOTES:

CPI = Characters Per Inch

The parameter is printed only with CUSTOM/POS emulation enabled.

SPEED / QUALITY

Setting of printing speed and printing quality:

Normal^D

High Quality

High Speed

PRINT WIDTH

Width of printing area:

<i>18 mm</i>	<i>34 mm</i>	<i>50 mm</i>	<i>66 mm</i>
<i>20 mm</i>	<i>36 mm</i>	<i>52 mm</i>	<i>68 mm</i>
<i>22 mm</i>	<i>38 mm</i>	<i>54 mm</i>	<i>70 mm</i>
<i>24 mm</i>	<i>40 mm</i>	<i>56 mm</i>	<i>72 mm</i>
<i>26 mm</i>	<i>42 mm</i>	<i>58 mm</i>	<i>74 mm</i>
<i>28 mm</i>	<i>44 mm</i>	<i>60 mm</i>	<i>76 mm</i>
<i>30 mm</i>	<i>46 mm</i>	<i>62 mm</i>	<i>78 mm</i>
<i>32 mm</i>	<i>48 mm</i>	<i>64 mm</i>	<i>80 mm^D</i>

PAPER THRESHOLD

Threshold value (in percent) for the recognition of the presence of paper by the paper presence sensor:

30% 70%

40%^D 80%

50% 90%

60%

NOTCH/B.MARK POSITION

Position of the alignment notch and choice of appropriate notch sensor:

Disabled^D = the notch alignment is not performed

Top = the notch position is detected by the upper sensor (reflection)

Bottom = the notch position is detected by the lower sensor (reflection)

Transparent = the notch is detected by the lower sensor and the upper sensor placed in front of (transparence)

NOTCH THRESHOLD

Threshold value (in percent) for the recognition of the presence of notch by the notch sensor:

30%	70%
40% ^D	80%
50%	90%
60%	

NOTE: If the "Notch/B.Mark position" parameter is disabled, this parameter is not printed.

NOTCH DISTANCE

"Notch Distance" is the minimum distance (in mm) between the upper edge of ticket and the notch (see chapter 10).

The numeric value of the distance is made up with the following four parameters for the setting of three digits (two for the integer part of the number, one for the decimal part and of the sign):

Sign setting:

NOTCH DISTANCE SIGN

+^D = positive distance
- = negative distance

Setting the digit for tens:

NOTCH DISTANCE [mm x 10]

0 ^D	2	4	6	8
1	3	5	7	9

Setting the digit for units:

NOTCH DISTANCE [mm x 1]

0 ^D	2	4	6	8
1	3	5	7	9

Setting the digit for decimals:

NOTCH DISTANCE [mm x .1]

0 ^D	2	4	6	8
1	3	5	7	9

NOTES:

For example, to set the notch distance to 15 mm, modify the parameters as follows:

Notch Distance Sign = +
Notch Distance [mm x 10] = 1
Notch Distance [mm x 1] = 5
Notch Distance [mm x .1] = 0

If the "Notch/B.Mark Position" parameter is disabled, the parameters for the "Notch Distance" are not printed.

**NOTCH/B.MARK
MIN. WIDTH**

Minimum length of the alignment notch:

<i>0 mm^D</i>	<i>6 mm</i>	<i>12 mm</i>	<i>18 mm</i>
<i>1 mm</i>	<i>7 mm</i>	<i>13 mm</i>	<i>19 mm</i>
<i>2 mm</i>	<i>8 mm</i>	<i>14 mm</i>	<i>20 mm</i>
<i>3 mm</i>	<i>9 mm</i>	<i>15 mm</i>	
<i>4 mm</i>	<i>10 mm</i>	<i>16 mm</i>	
<i>5 mm</i>	<i>11 mm</i>	<i>17 mm</i>	

NOTES:

If the "Notch/B.Mark Position" parameter is disabled, the parameter is not printed.

The parameter "Notch/B.Mark Min. Width" is used to set the notch dimensions in order to avoid that other graphics present on the ticket can be detected as a Notch/B.Mark.

TICKET LOCKING

This parameter enables/disables the block of the paper inside the device where the ticket is not cut with the cutter, but is presented for the manual tear off by the user:

Disabled^D = paper block disabled

Enabled = paper block enabled

NOTE: If the "Notch/B.Mark Position" parameter is disabled, the parameter is not printed.

TICKET MANAGEMENT

This parameter allows the ticket management:

Disabled^D = no check

Check First = before printing, the device checks the integrity of the first ticket

CASING TYPE

Type of device casing:

Plastic^D = plastic casing

Metal = metallic casing

NOTE:

The parameter is printed only for TK180 models.

**PRINTHEAD TEST
POWER ON**

Setting of the performing of the print head test:

Disabled^D = the test is performed only during the printing of the setup report

Enabled = the test is performed at each power on

PRINT DENSITY

Adjusting the printing density:

-50% -12% +25%

-37% 0^D +37%

-25% +12% +50%

5.5 Ethernet parameters

Models with ETHERNET port

These devices allow the configuration of the parameters listed in the following table.

The parameters marked with the symbol ^D are the default values.

Settings remain active even after the device has been turned off and they are stored in non-volatile memory.

DHCP CLIENT	<i>Setting of the DHCP protocol:</i> <i>Disabled ^D = protocol disabled</i> <i>Enabled = protocol enabled</i>
IP ADDRESS	<i>IP address of device; this parameter is assigned by the network administrator.</i> NOTE: Press the FEED key to modify the value of the highlighted digit. Pressing OPEN key to move the cursor on the next digit (if the cursor is on the latest digit, proceed to next parameter by pressing the OPEN key).
SUBNET MASK	<i>This parameter identifies the local network address.</i> NOTE: Press the FEED key to modify the value of the highlighted digit. Pressing OPEN key to move the cursor on the next digit (if the cursor is on the latest digit, proceed to next parameter by pressing the OPEN key).
DEFAULT GATEWAY	<i>This parameter identifies the Gateway IP address used to send applications to the external network.</i> NOTE: Press the FEED key to modify the value of the highlighted digit. Pressing OPEN key to move the cursor on the next digit (if the cursor is on the latest digit, proceed to next parameter by pressing the OPEN key).
DOMAIN NAME SYSTEM	<i>This parameter identifies the Domain Name System (DNS).</i> NOTE: This parameter is not printed on Setup Report, because it is not modifiable during the Setup procedure. To set this parameter, enter the Setup.ini file (see par.12.5).
TCP PRINTER PORT	<i>This parameter sets the TCP port number.</i> NOTE: This parameter is not printed on Setup Report, because it is not modifiable during the Setup procedure. To set this parameter, enter the Setup.ini file (see par.12.5).
MAC ADDRESS	<i>This is the number, provided by the constructor, that identifies the device; this number is univocal.</i> NOTE: This parameter can't be modified by set up.

ATTENTION: Any changes to network parameters will interrupt browser connection. If the server not responding you must reconnect to the new IP address set.

5.6 Hexadecimal dump

This function is used for the diagnosis of the characters received from the communications port. Characters are printed as hexadecimal code and the corresponding ASCII code (see below). Each line is preceded by a counter in hexadecimal that indicates the number of bytes received.

During the startup, if you hold down the FEED key, the device enters the self-test routine and print the setup report. The device remains in standby until a key is pressed or characters are received through the communication port (Hexadecimal Dump mode). For each character sent, the ticket shows the hexadecimal value and the ASCII codes (if the characters are underlined, the receive buffer is full). Shown below is an example of a Hexadecimal Dump:

HEXADECIMAL DUMP									
31	32	33	34	35	...	12345	...		
39	30	31	32	33	...	90123	...		
37	38	39	75	69	...	789ui	...		
68	6B	6A	73	64	...	hkjsd	...		
73	64	66	6B	6A	...	sdfkj	...		
66	73	64	66	6B	...	fsdfk	...		
65	69	6F	79	75	...	eioyu	...		
6F	72	69	75	77	...	oriuw	...		
6F	75	77	65	72	...	ouwer	...		
77	65	72	69	6F	...	werio	...		
72	69	6F	75	77	...	riouw	...		
6B	6C	73	64	66	...	kl sdf	...		
64	66	6B	73	64	...	dfksd	...		
73	64	66	6B	6A	...	sdfkj	...		
66	6B	F2	6A	73	...	fk>j	...		
6A	6B	6C	68			jklh			

6 MAINTENANCE

6.1 Printer paper jam

1

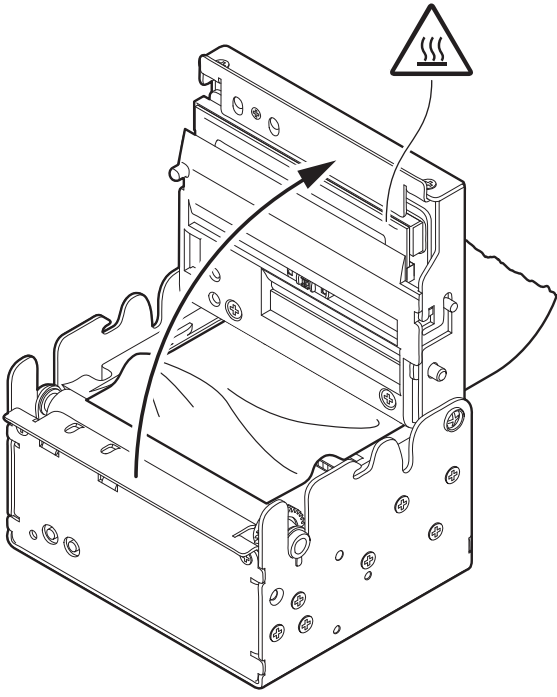

Open the device cover
(see previous paragraphs).

2

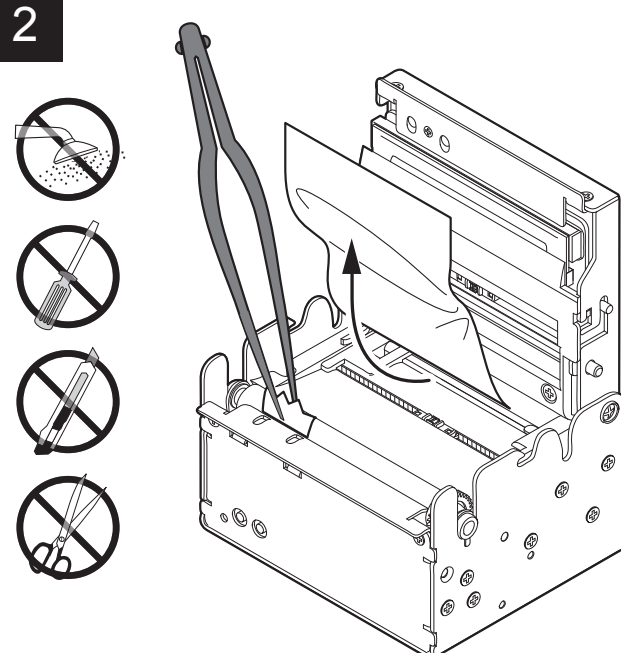

Remove the damaged paper and check the presence for paper scraps inside the device. Carefully remove all paper scraps. If necessary use tweezers.

3

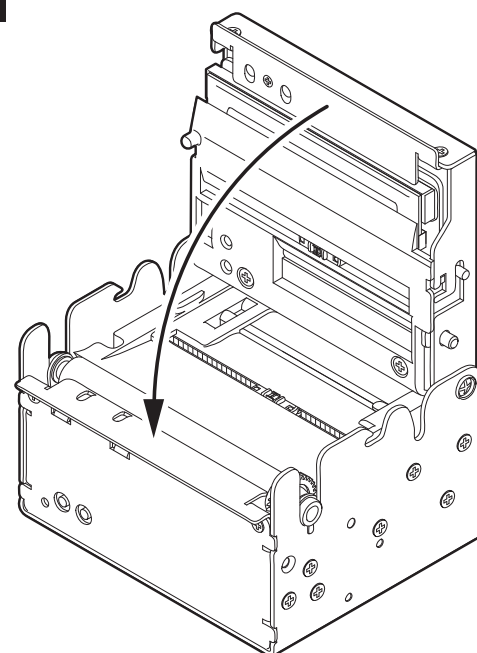

Close the device cover.

4

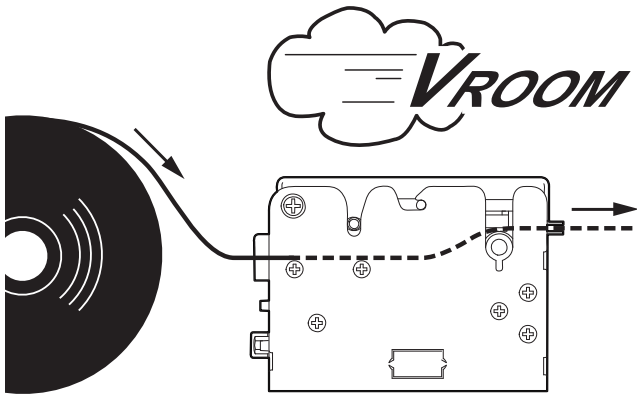

Insert the paper
(see previous paragraphs).

NOTE: For some models, only the internal printer group is represented.

6.2 Cutter paper jam

KPM180H (models with presenter)

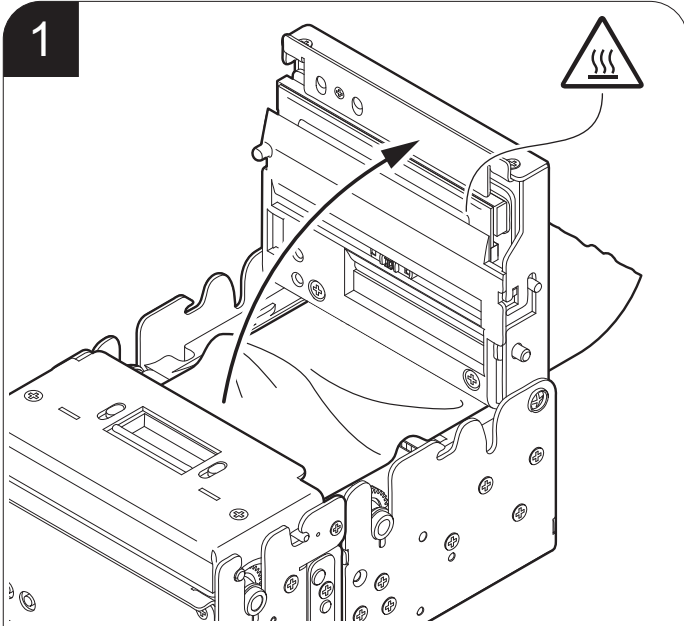

1
Open the printer cover
(see previous paragraphs).

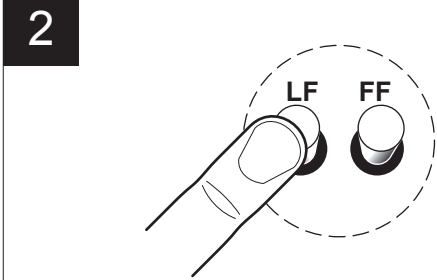

2
Start the automatic unlocking procedure
by pressing the LF LINE FEED key.

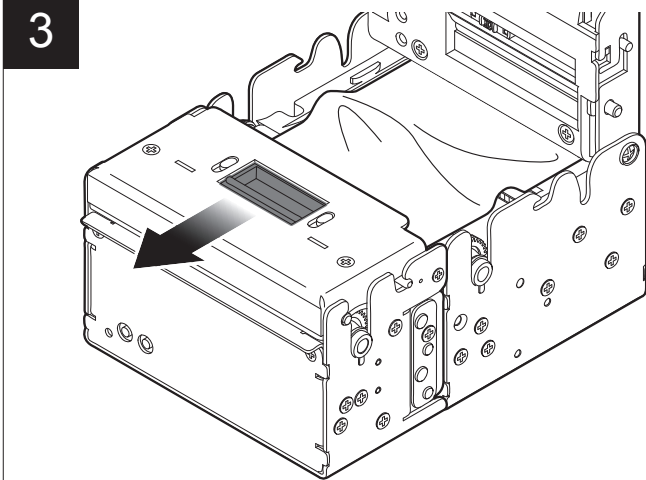

3
Push the opening lever
of the presenter.

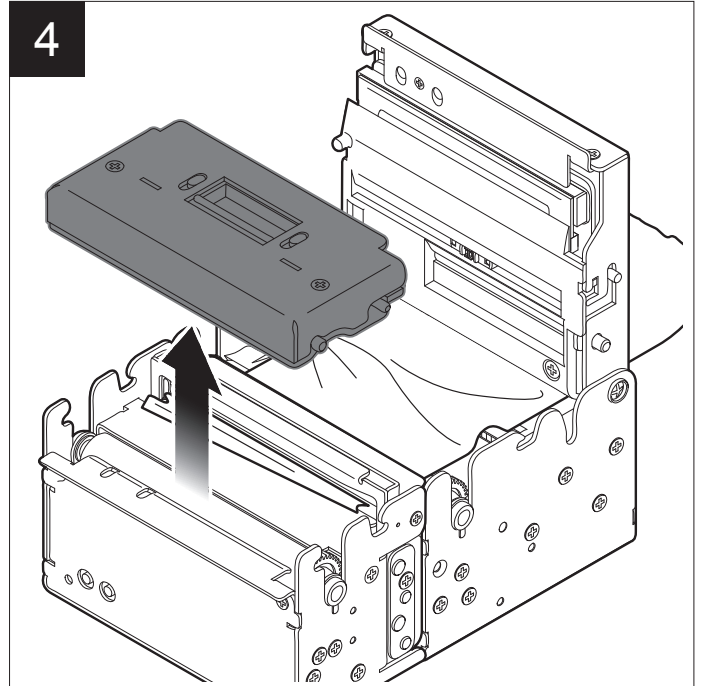

4
Lift the cover
of the presenter.

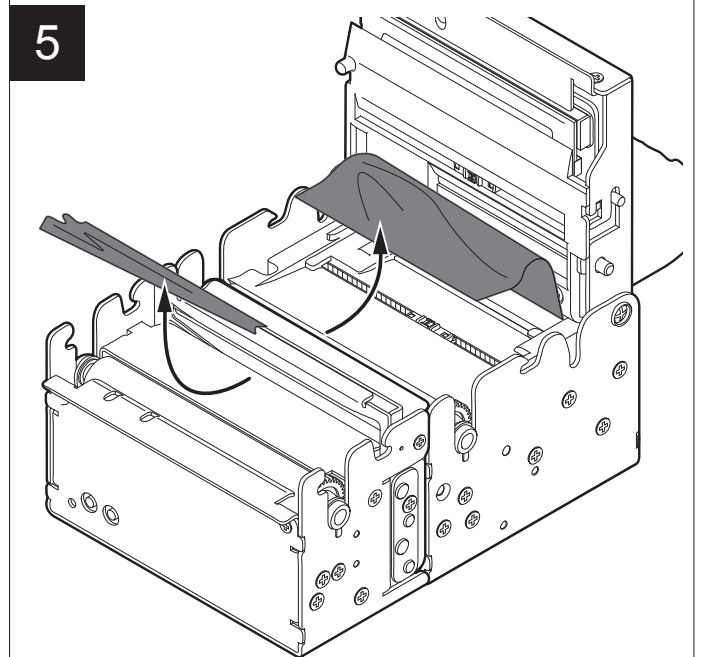

5
Try to remove the paper.
If the operation fails, see the next point.

6

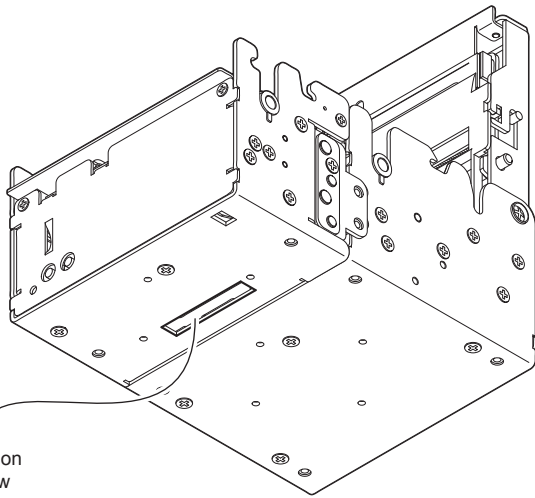

Inspection window

Locate the inspection window for the cutter placed in the bottom of the presenter

7

Blade

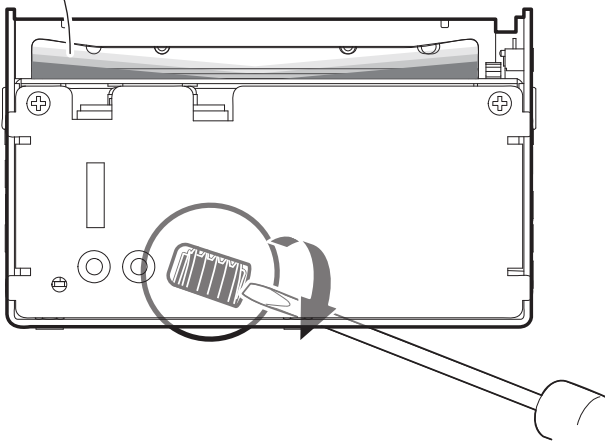

Insert a Phillips screwdriver in the inspector window and turn the worm screw to lower the cutter blade.

8

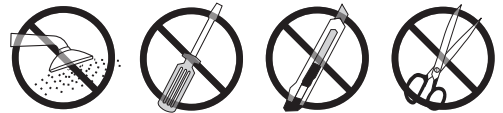
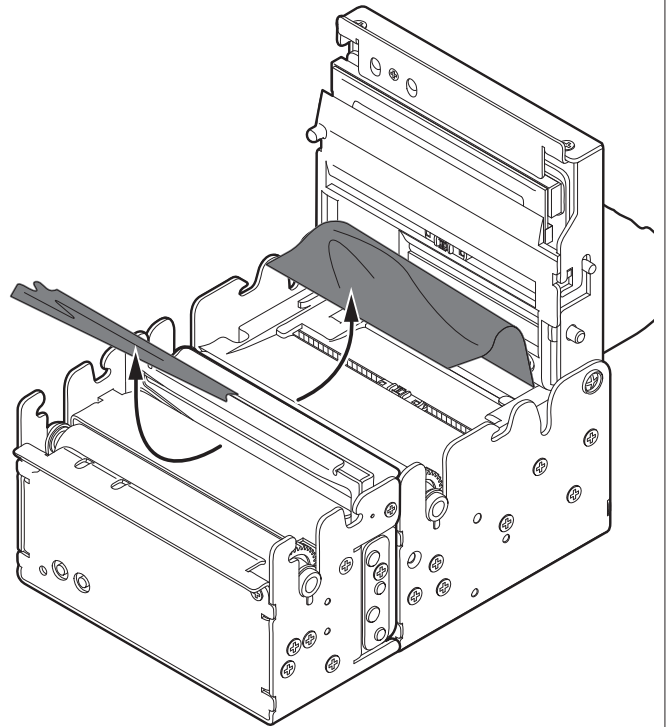

Remove the damaged paper and check the presence for paper scraps inside the printer; carefully remove all scraps of paper. If necessary, use tweezers.

6.3 Planning of cleaning operations

The regular cleaning of the device keeps the print quality and extends its life. The following table shows the recommended planning for the cleaning operations.

EVERY PAPER CHANGE	
Printing head	Use isopropyl alcohol
Rollers	Use isopropyl alcohol
EVERY 5 PAPER CHANGES	
Cutter ⁽¹⁾	Use compressed air
Paper path	Use compressed air or tweezers
Sensors	Use compressed air
EVERY 6 MONTHS OR AS NEEDED	
Display ⁽²⁾	Use compressed air or a soft cloth
Case	Use compressed air or a soft cloth

For specific procedures, see the following pages.

NOTES:

If you use the device in dusty environments, you must reduce the intervals between the cleaning operations.

For some models, only the internal printer group is represented.

(1) Only for KPM180H with presenter.

(2) Only for TK180. Don't use any ammonia-based product.

6.4 Cleaning

For periodic cleaning of the device, see the instructions below

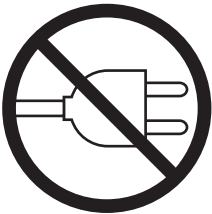

Sensors

1





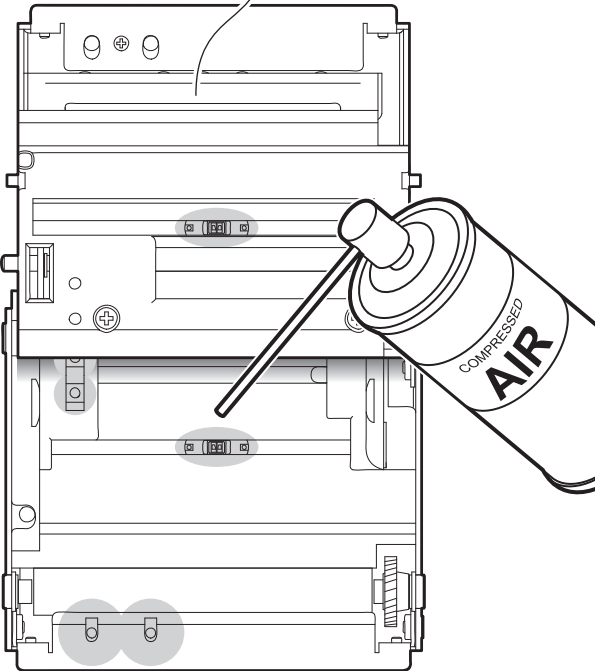

Disconnect the power supply cable and open the device cover (see par.4.1).

2



ATTENTION:
Do not use alcohol, solvents, or hard brushes.
Do not let water or other liquids get inside the device.



Clean the device sensors by using compressed air.

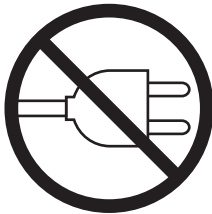

Paper path

1





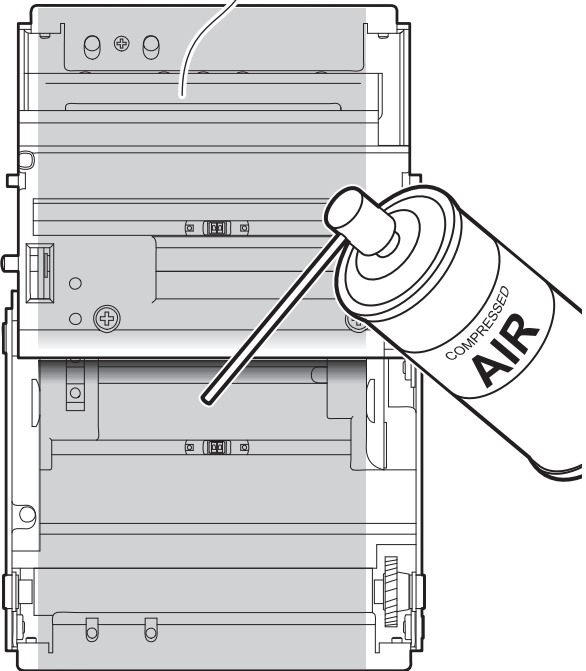

Disconnect the power supply cable and open the device cover (see par.4.1).

2



ATTENTION:
Do not use alcohol, solvents, or hard brushes.
Do not let water or other liquids get inside the device.



Clean the area involved in the passage of paper by using compressed air.

Printing head

1

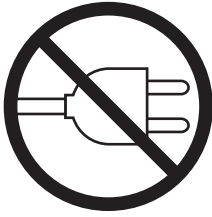

Disconnect the power supply cable and open the device cover (see par.4.1).

2

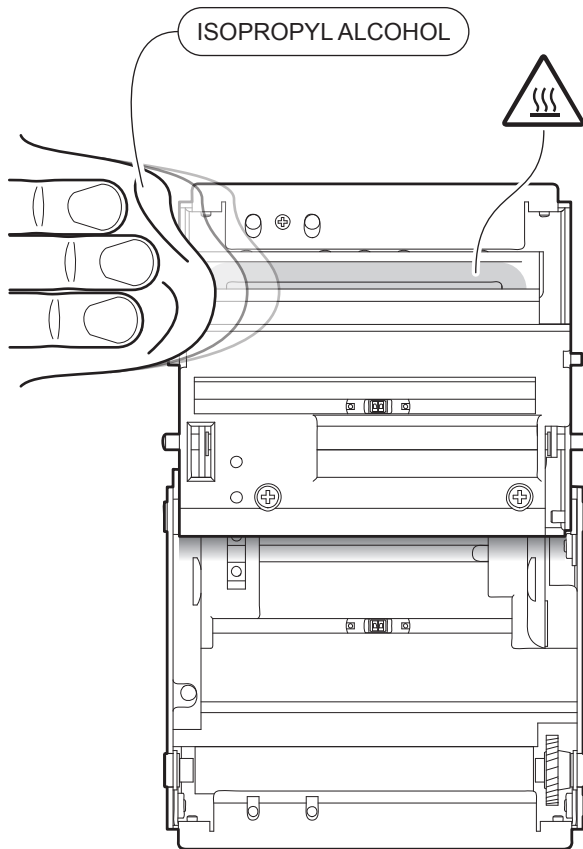

ATTENTION:

Do not use solvents, or hard brushes.
Do not let water or other liquids get inside the machine.



Clean the printing head by using a non-abrasive cloth moistened with isopropyl.

Printing roller

1

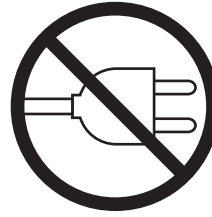

Disconnect the power supply cable and open the device cover (see par.4.1).

2

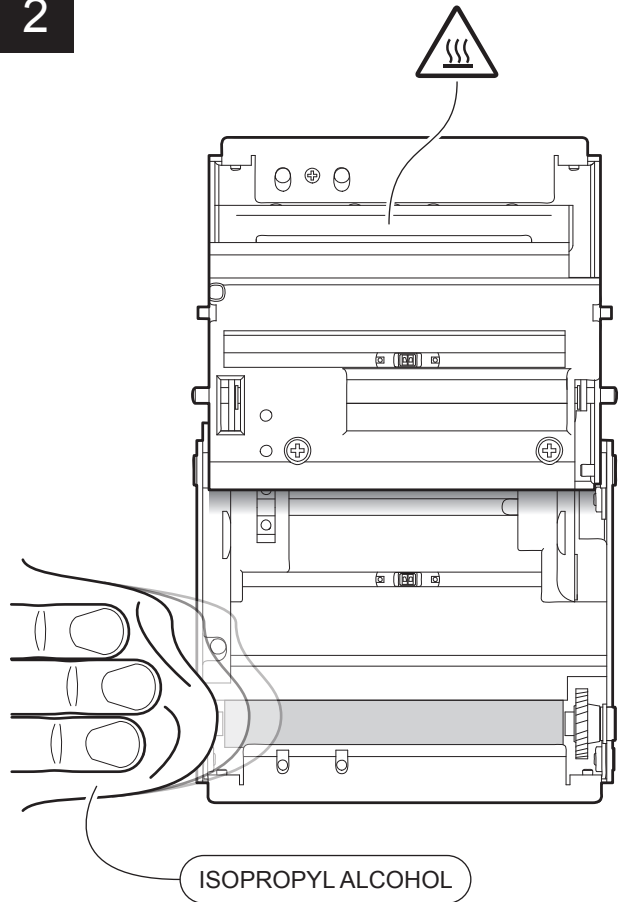

ATTENTION:

Do not use solvents, or hard brushes.
Do not let water or other liquids get inside the machine.



Clean the printing roller by using a non-abrasive cloth moistened with isopropyl.

Cutter

1

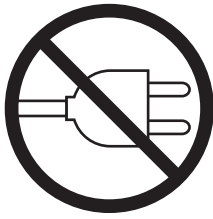

Disconnect the power supply cable and open the device cover (see par.4.1).

2

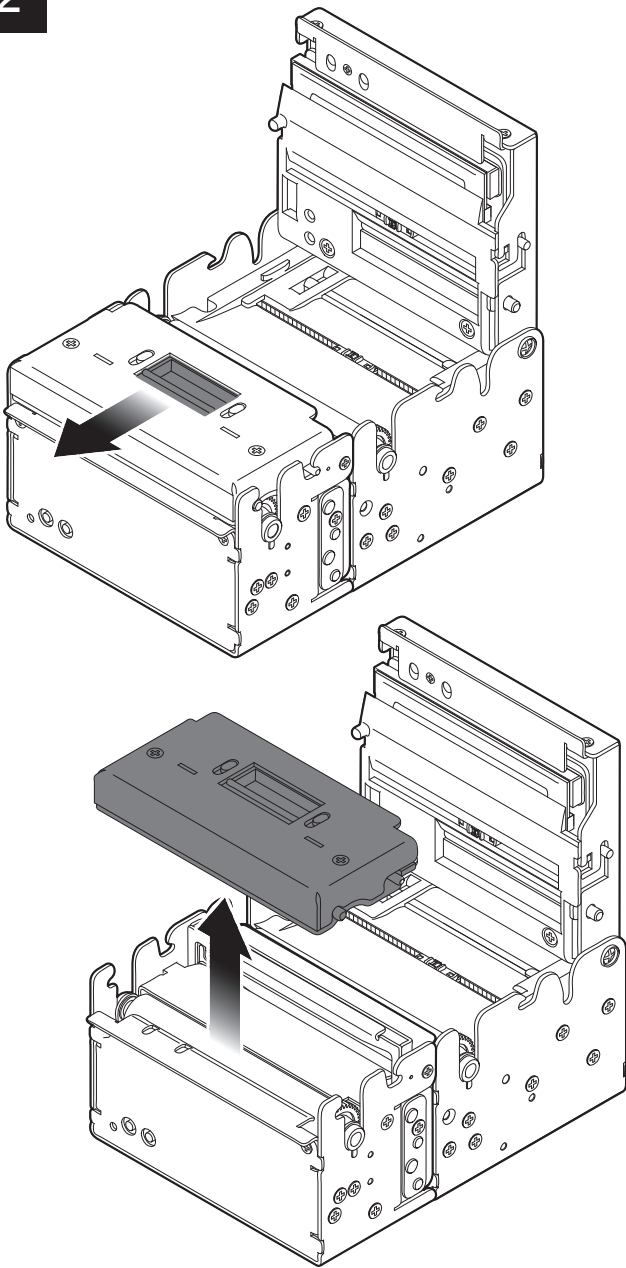

Push the opening lever and lift the presenter cover.

3

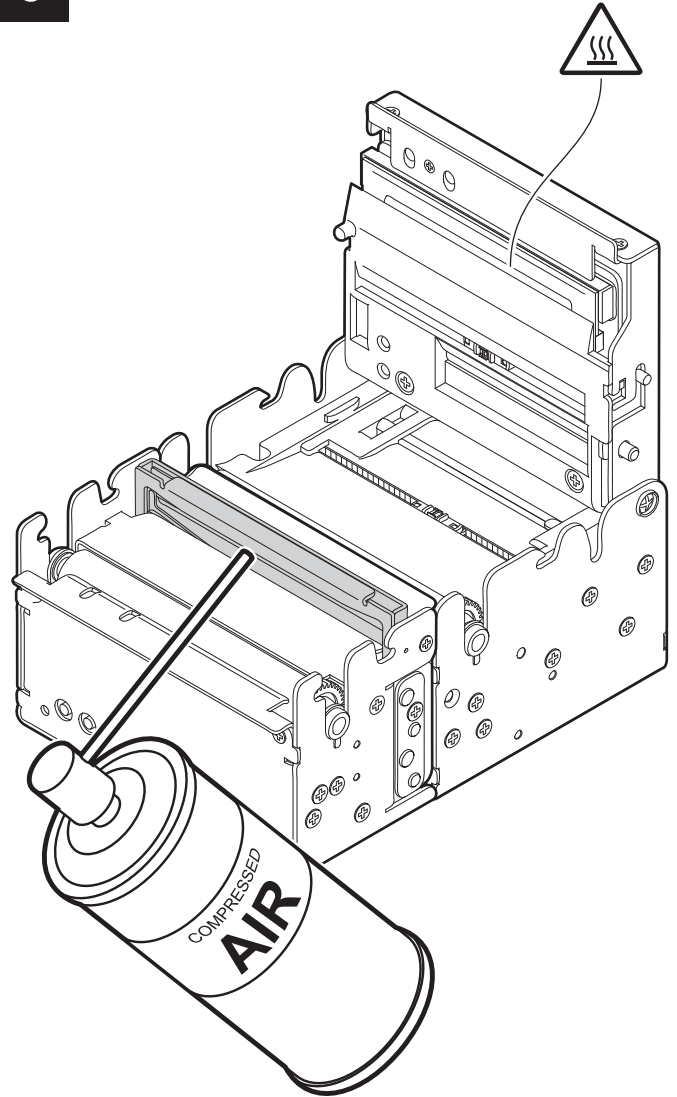

ATTENTION:
Do not use alcohol, solvents, or hard brushes.
Do not let water or other liquids get inside the device.



Clean the cutter by using compressed air.

Case

1

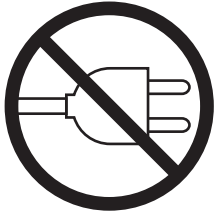

Disconnect the power supply cable.

2

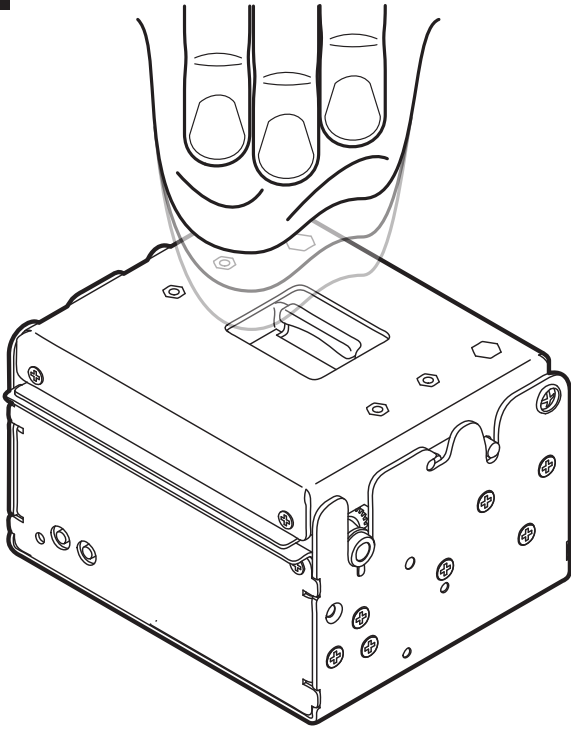

ATTENTION:

Do not use alcohol, solvents, or hard brushes.
Do not let water or other liquids get inside the device.



To clean the device,
use compressed air or a soft cloth.

Display

1

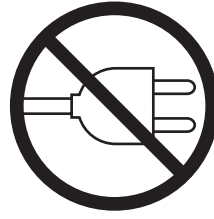

Disconnect the power supply cable.

2

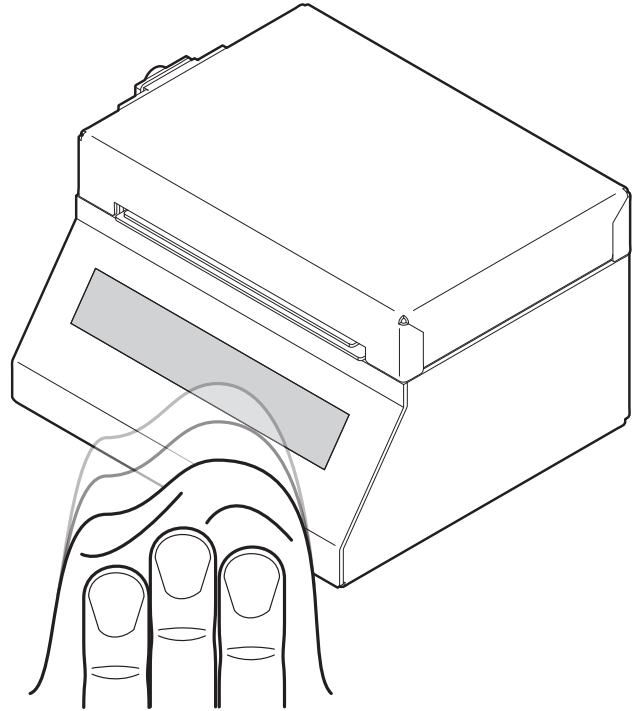

ATTENTION:

Do not use alcohol, solvents, or hard brushes.
Do not let water or other liquids get inside the machine.
Do not use ammonia-based products .



To clean the display,
use compressed air or a soft cloth.

6.5 Upgrade firmware

WARNING: During communication between PC and device for the firmware update it is strictly forbidden to disconnect the communication cable or to remove the power supply of the devices not to endanger the proper functioning of the machine.

NOTES:

The latest firmware is available in the download area of the web site www.custom.biz

Install on the PC used for device upgrading the UPG-CEPRN software available in the download area of the web site www.custom.biz.

Update via serial interface

Proceed as follows:

1. Write down the product code (14 digits) printed on the product label (see par.2.5).
2. Go to the web site www.custom.biz and download the appropriate firmware release from the DOWNLOAD area.
3. Print the SETUP report (see chapter 5).
4. Switch OFF the device.
5. Connect the device to the PC using a serial cable (see par.3.3).
6. Switch ON the device.
7. Launch the software UPGCEPRN.
8. Select the update file .PSW location:

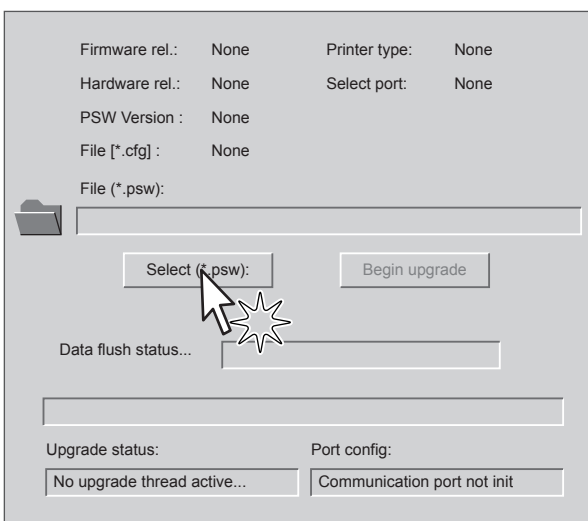

9. Select the serial communication port (e.g. COM1):

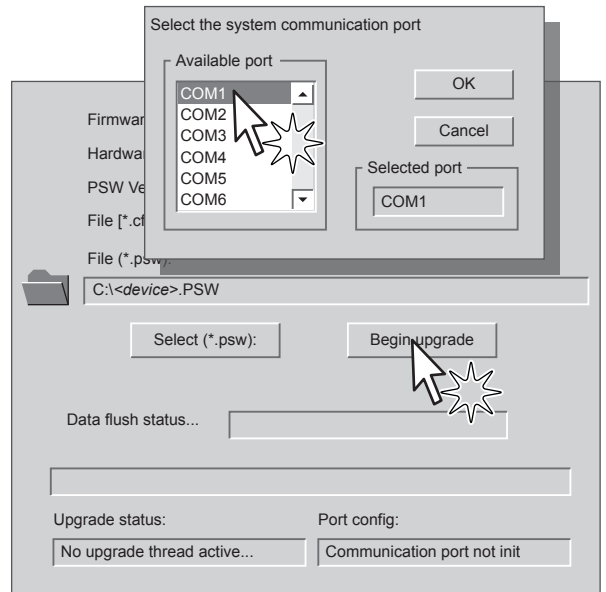

10. Detecting and setting of the parameters necessary for serial communication are performed automatically and then updating begins.
11. After a few minutes a message on the screen warns that the update is completed.

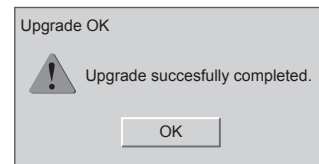

12. Print a new SETUP report to verify the new firmware release (see chapter 5).

Update via USB interface

ATTENTION:

Only during the firmware update, the connection between PC and device must be direct, without the use of HUB device.

Only during the firmware update, do not connect or disconnect other USB devices.

NOTE: For communication via USB you must install on PC the device driver available in the download area of the web site www.custom.biz.

Proceed as follows:

1. Write down the product code (14 digits) printed on the product label (see par.2.4).
2. Go to the web site www.custom.biz and download the appropriate firmware release from the DOWNLOAD area.
3. Print the SETUP report (see chapter 5).
4. Switch OFF the device.
5. Connect the device to the PC using a USB cable (see paragraph 3.3).
6. Switch ON the device.
7. Launch the software UPGCEPRN.
8. Select the update file .PSW location:

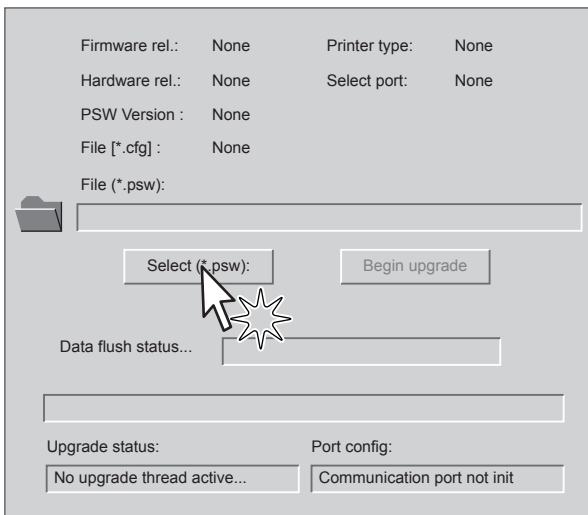

9. Select item USB and then select the USB device among those proposed (e.g. device1):

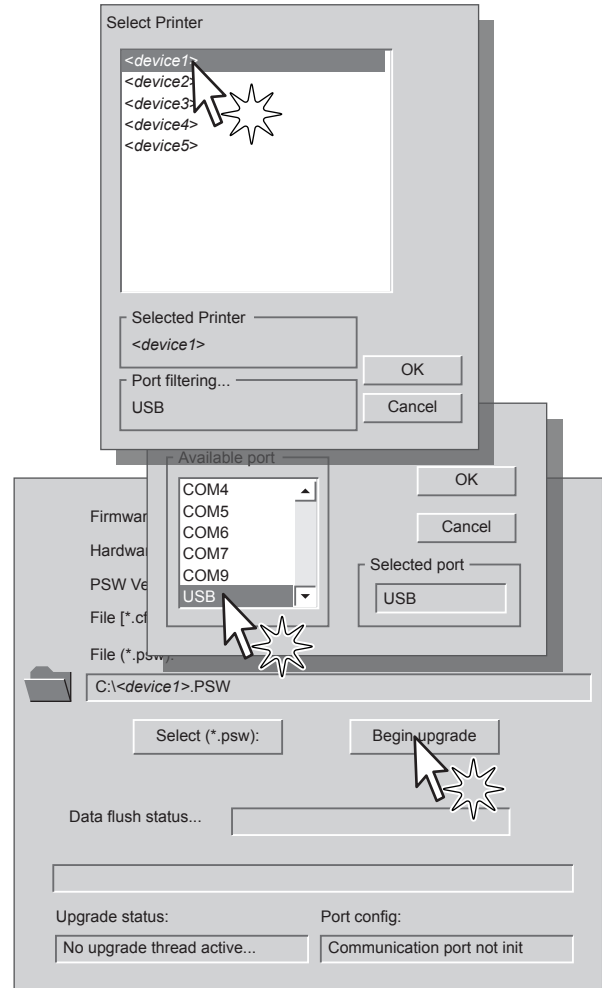

10. After a few minutes a message on the screen warns that the update is completed.

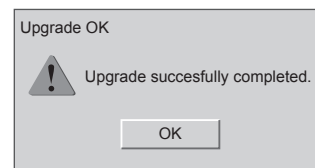

11. Print a new SETUP report to verify the new firmware release (see chapter 5).

7 SPECIFICATION

7.1 Hardware specifications

Operating temperature	
Sensors	Head temperature, paper presence, mobile detectors of black mark or translucent gap/hole (setting by software), cover open, external near paper end,
MTBF ⁽¹⁾	113 000 hours
Emulations	CUSTOM/POS, SVELTA
Printing driver	Windows XP VISTA (32/64bit) Windows 7 (32/64bit) Windows 8 (32/64bit) Linux Android iOS
INTERFACES	
USB port	12 Mbit/sec (USB 2.0 full speed)
RS232 serial port	from 1200 to 115200 bps
ETHERNET port (models with ETHERNET port)	10 Mbit/sec, 100 Mbit/sec
MEMORIES	
Receive buffer	16 Kbytes
Flash memory	1 Mbytes internal + 8 Mbytes external (of which 4Mbytes available for user)
RAM memory	128 Kbytes internal + 8Mbytes external
PRINTER	
Resolution	
200dpi models	203 dpi (8 dot/mm)
300dpi models	304 dpi (12 dot/mm)
Printing method	Thermal, fixed head

Head life ⁽²⁾	100 Km / 100M pulse
Printing width	80 mm
Printing mode	Normal, 90°, 180°, 270°
Printing format	Height/Width from 1 to 8, bold, reverse, underlined, italic
Character fonts	
CUSTOM/POS emulation	54 character code tables (see par. 7.8) 2 TrueType font ⁽³⁾ , extended chinese GB18030-2000
SVELTA emulation	20 embedded fonts, 2 TrueType font ⁽³⁾
Printable barcode	UPCA, UPCE, EAN13, EAN8, CODE39, ITF, CODABAR, CODE93, CODE128, CODE32, PDF417, DATAMATRIX, AZTEC, QRCODE
Printing speed ^{(2) (4)}	
200dpi models	High Speed = 200 mm/sec Normal = 150 mm/sec High Quality = 100 mm/sec
300dpi models	High Speed = 150 mm/sec Normal = 120 mm/sec High Quality = 90 mm/sec
PAPER	
Type of paper	Thermal rolls, heat-sensitive side on outside of roll Thermal rolls, heat-sensitive side on inside of roll Thermal fanfold module with alignment notch
Paper width	from 20 mm to 82.5 mm (2 mm step)
Paper weight	from 70 g/m ² to 255 g/m ²
Paper thickness	max 270 µm
Recommended types of paper	KANZAN KF50 and KP460 MITSUBISHI PG5075 and TL4000
External roll diameter ⁽⁵⁾	max. 200 mm
External roll core diameter	25 mm (+ 1mm)
Paper end	Not attached to roll core

Core type	Cardboard or plastic
-----------	----------------------

CUTTER (models with presenter)	
--------------------------------	--

Paper cut	Total
-----------	-------

Estimated life ⁽²⁾	1 000 000 cutter number
-------------------------------	-------------------------

DEVICE ELECTRICAL SPECIFICATIONS	
----------------------------------	--

Power supply	24 Vdc ±10% (optional external power supply)
--------------	--

Medium consumption ⁽⁴⁾	1.5 A
-----------------------------------	-------

Stand-by consumption	
----------------------	--

200dpi models	0.04 A
---------------	--------

300dpi models	0.06 A
---------------	--------

ELECTRICAL SPECIFICATIONS POWER SUPPLY cod.963GE020000003	
---	--

Power supply voltage	from 100 Vac to 240 Vac
----------------------	-------------------------

Frequency	from 50 Hz to 60 Hz
-----------	---------------------

Current (output)	2.5 A
------------------	-------

Power	60 W
-------	------

ENVIRONMENTAL CONDITIONS	
--------------------------	--

Operating temperature	from 0°C to +50°C
-----------------------	-------------------

Relative humidity	from 10% Rh to 85% Rh
-------------------	-----------------------

Storage temperature	from -20 °C to +70 °C
---------------------	-----------------------

Storage relative humidity	from 10% Rh to 90% Rh
---------------------------	-----------------------

NOTES:

(1) : Control board.

(2) : Respecting the regular schedule of cleaning for the device components.

(3) : "Veramono.ttf" and "Vera.ttf" are installed on the device. It is possible to install additional TrueType fonts (see par.12.4).

(4) : Referred to a standard CUSTOM receipt (L=10cm, Density = 12,5% dots on).

(5) : For external rolls diameter larger than Ø100mm it's recommended to use a paper pretensioning device.

7.2 Character specifications in CUSTOM/POS emulation

200dpi models

Character set		3	
Character density	11 cpi	15 cpi	20 cpi
Number of columns	35	45	64
Chars / sec	2370	3047	4266
Lines / sec	66	66	66
Characters (L x H mm)-Normal	2.25 x 3	1.75 x 3	1.25 x 3

300dpi models

Character set		3	
Character density	11 cpi	15 cpi	20 cpi
Number of columns	53	68	96
Chars / sec	4000	5142	7200
Lines / sec	75	75	75
Characters (L x H mm)-Normal	1.5 x 3	1.2 x 3	0.8 x 3

7.3 Device dimensions

KPM180H (standard models)

Length	97.5 mm
Height	67 mm
Width	108 mm
Weight	800 g

NOTE: All the dimensions shown in following figures are in millimetres.

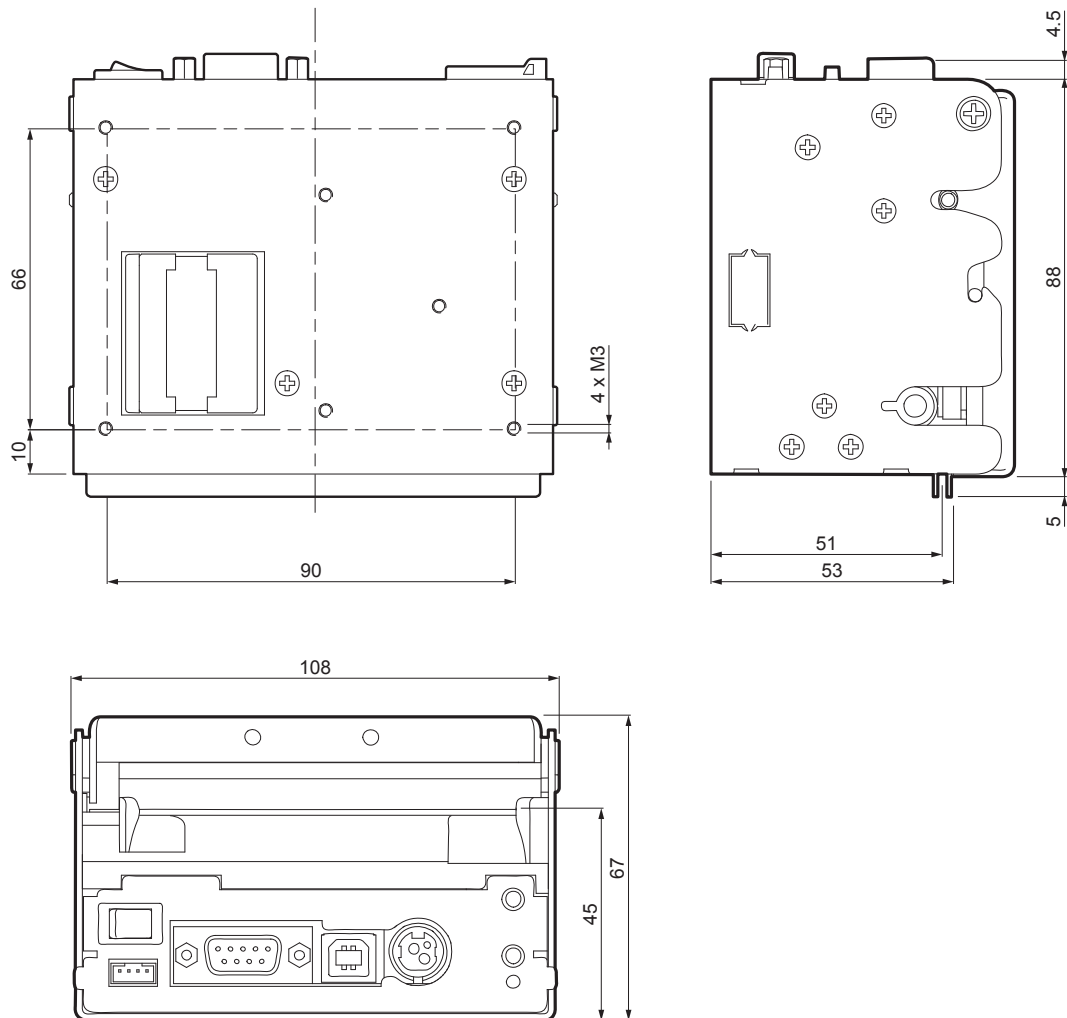

KPM180H (models with presenter)

Length	149 mm
Height	67 mm
Width	108 mm
Weight	1 500 g

NOTE: All the dimensions shown in following figures are in millimetres.

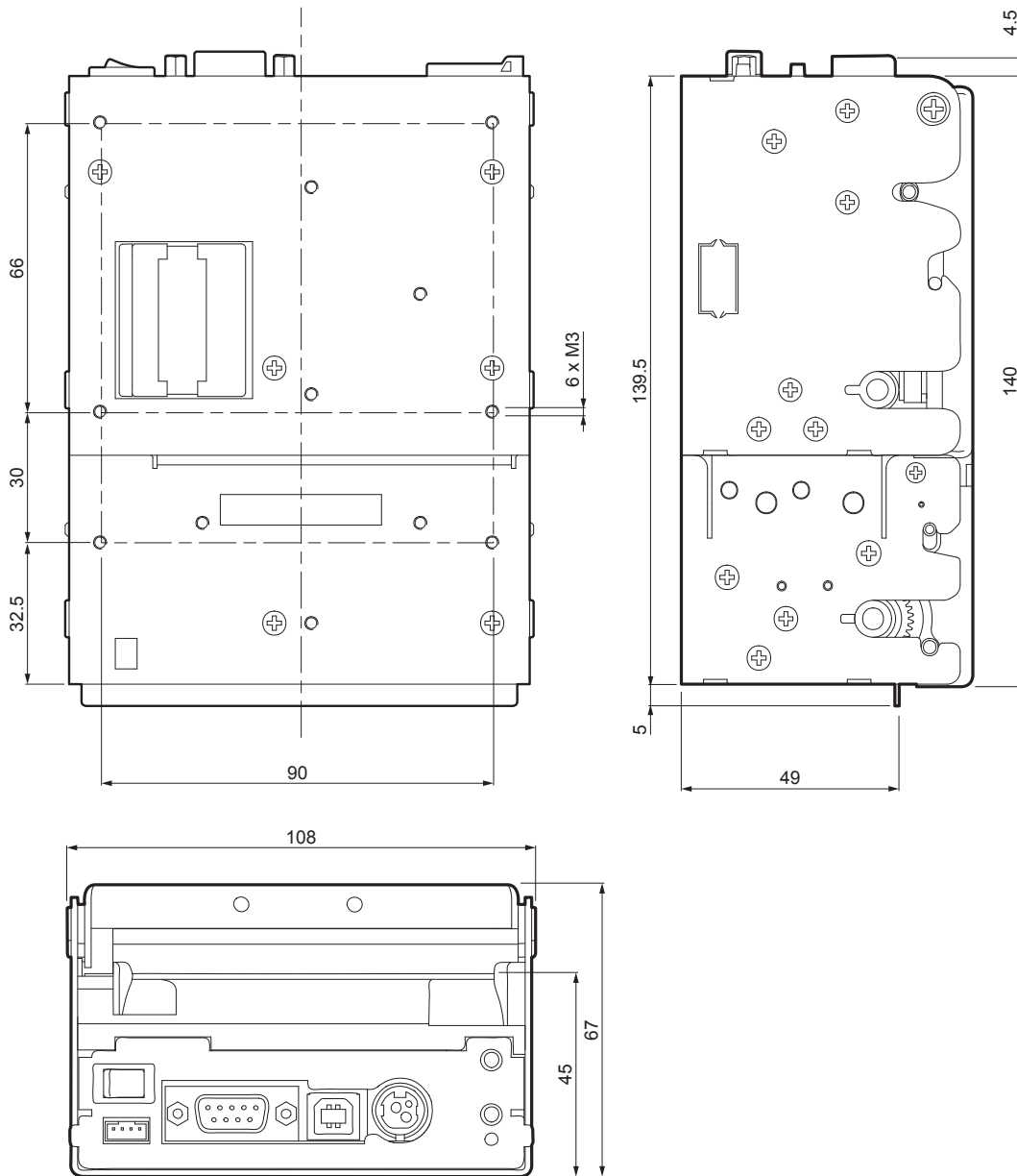

TK180 (metallic models)

Length	122.6 mm
Height	85 mm
Width	145.6 mm
Weight	2 240 g

NOTE: All the dimensions shown in following figures are in millimetres.

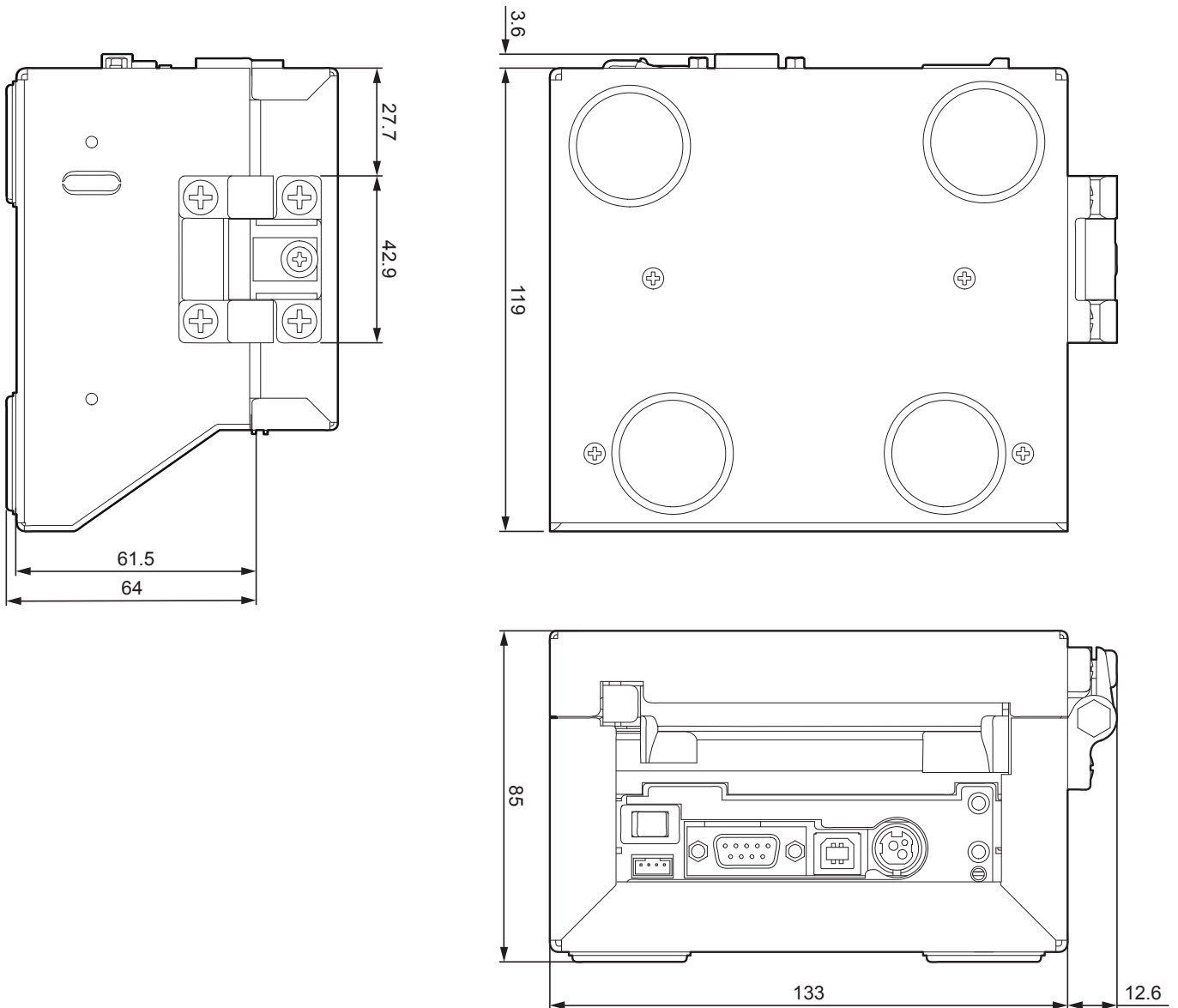

TK180 (plastic models)

Length	185.9 mm
Height	118.9 mm
Width	130 mm
Weight	1 940 g

NOTE: All the dimensions shown in following figures are in millimetres.

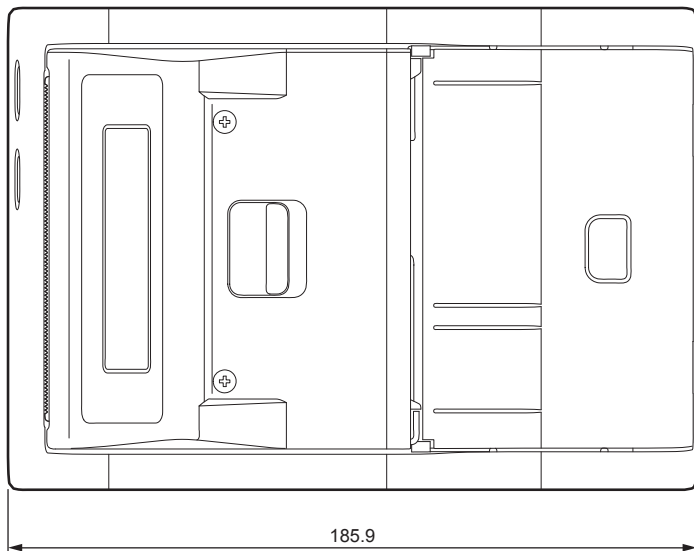
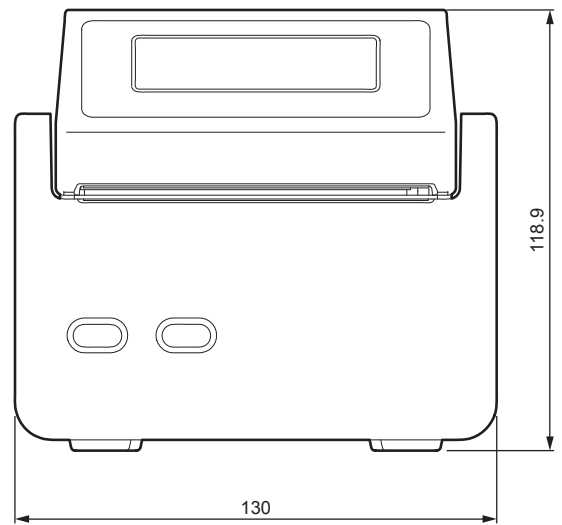
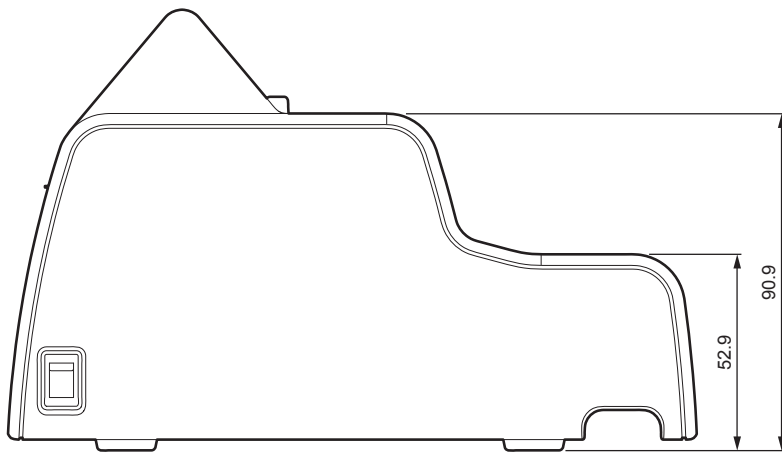

7.4 Device dimensions with paper roll holder

TK180 (metallic models)

Length	324 mm
Height	158 mm
Width	145.6 mm
Weight	3 240 g

NOTE: All the dimensions shown in following figures are in millimetres.

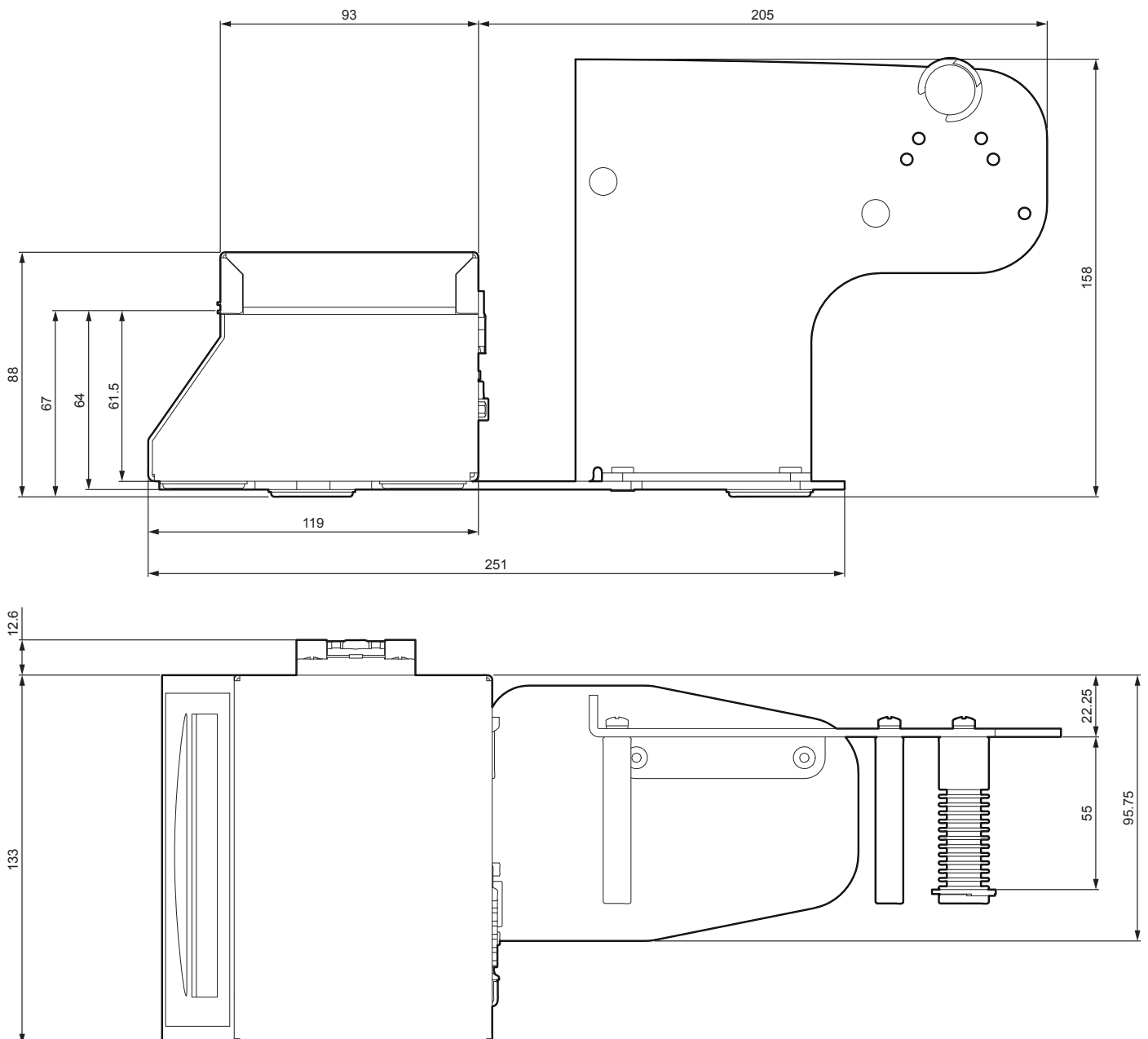

TK180 (plastic models)

Length	371.4 mm
Height	210.8 mm
Width	136.5 mm
Weight	2 840 g

NOTE: All the dimensions shown in following figures are in millimetres.

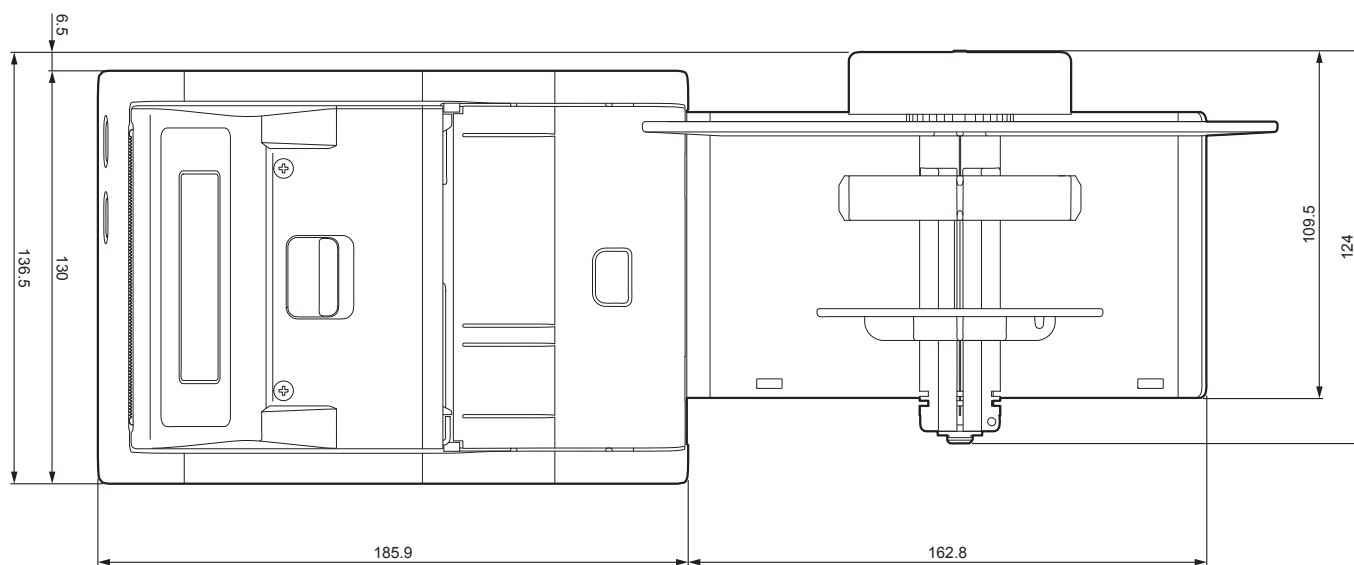
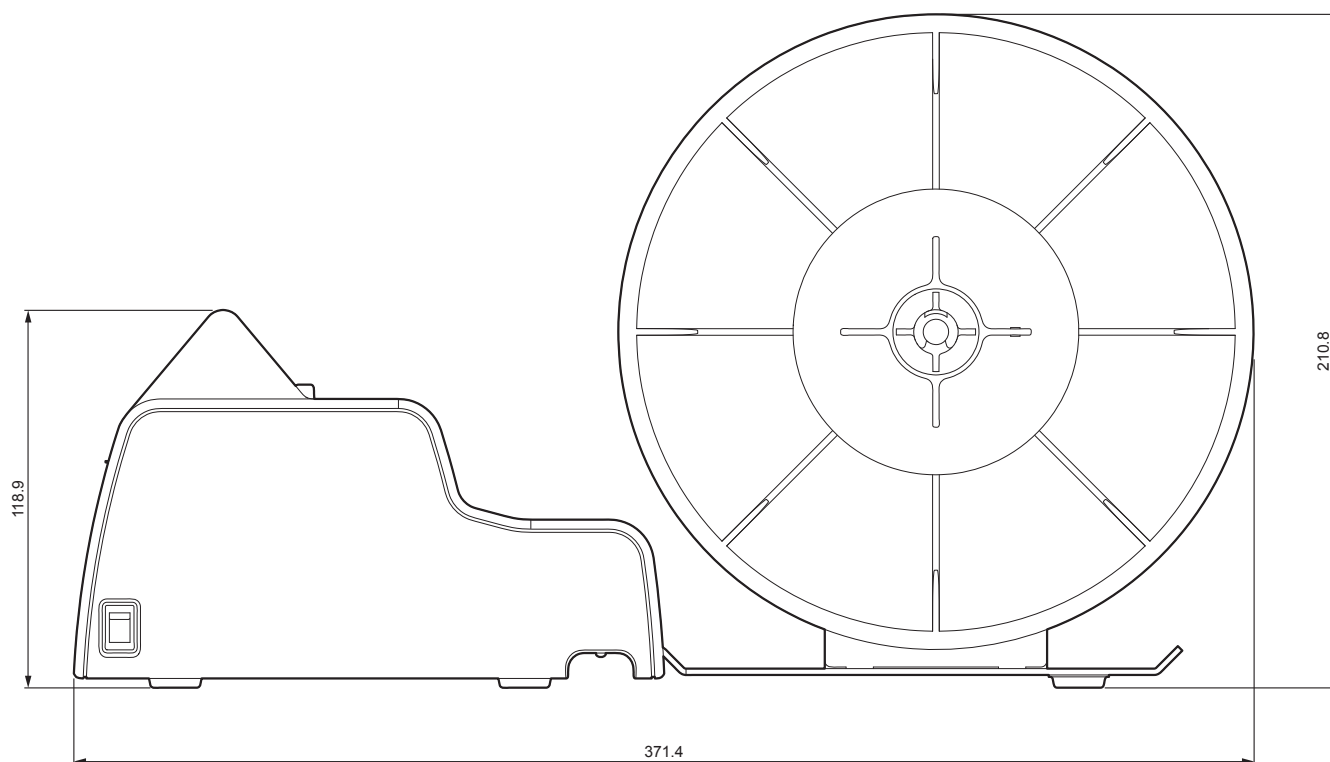

7.5 Dimensions of paper roll holder cod. 963GE020000003

KPM180H

The following figure shows the specifications for the paper roll holder provided as an accessory for the device and the dimension of the related paper roll to use.

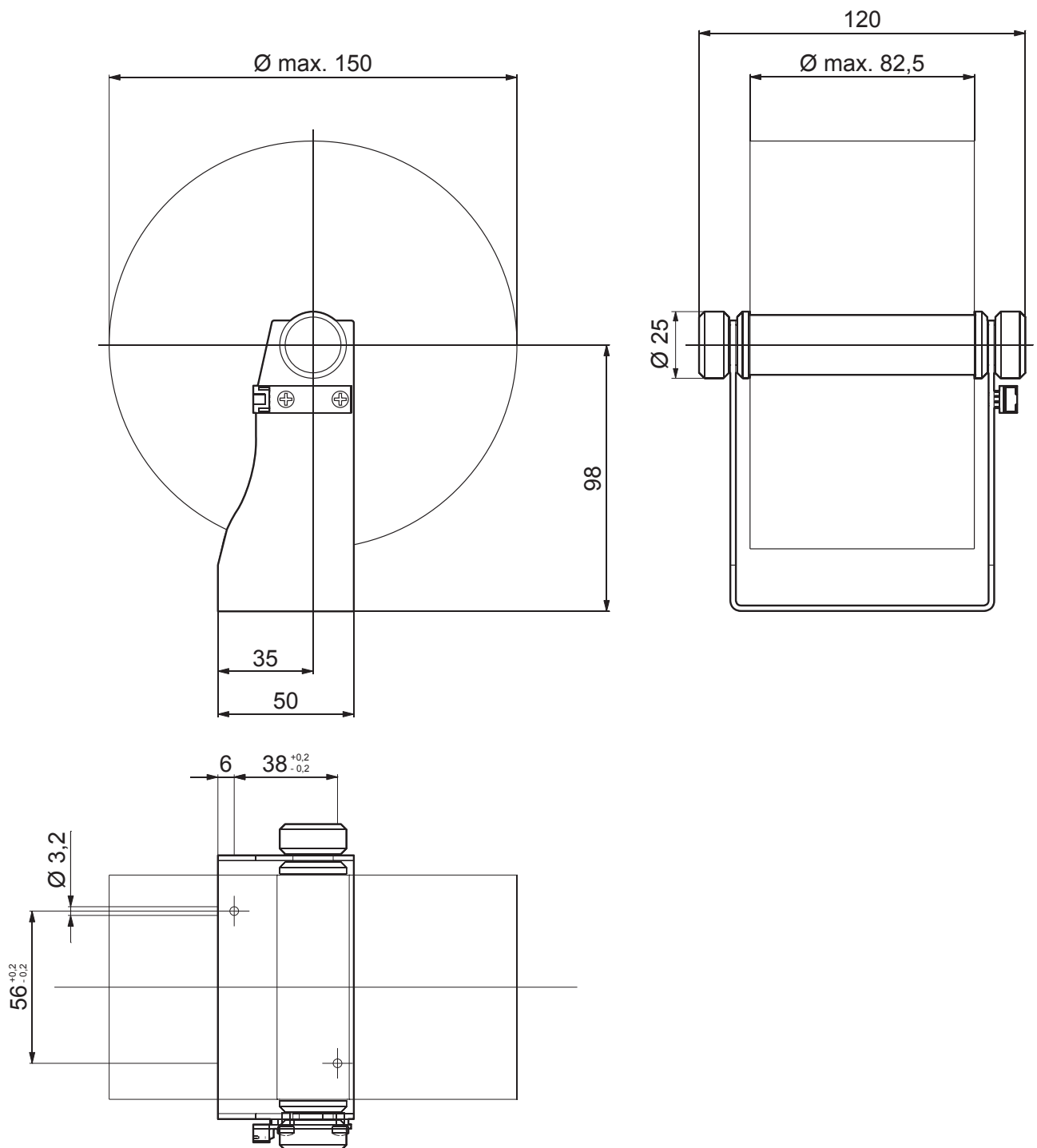

NOTES:

All the dimensions in figure are in millimetres.

For external rolls diameter larger than 100 mm it's recommended to use a paper pre-tensioning device.

7.6 Dimensions of power supply cod. 963GE020000003

Length	127 mm
Height	35.5 mm
Width	56 mm

NOTE:
All the dimensions shown in following figures are in millimetres.

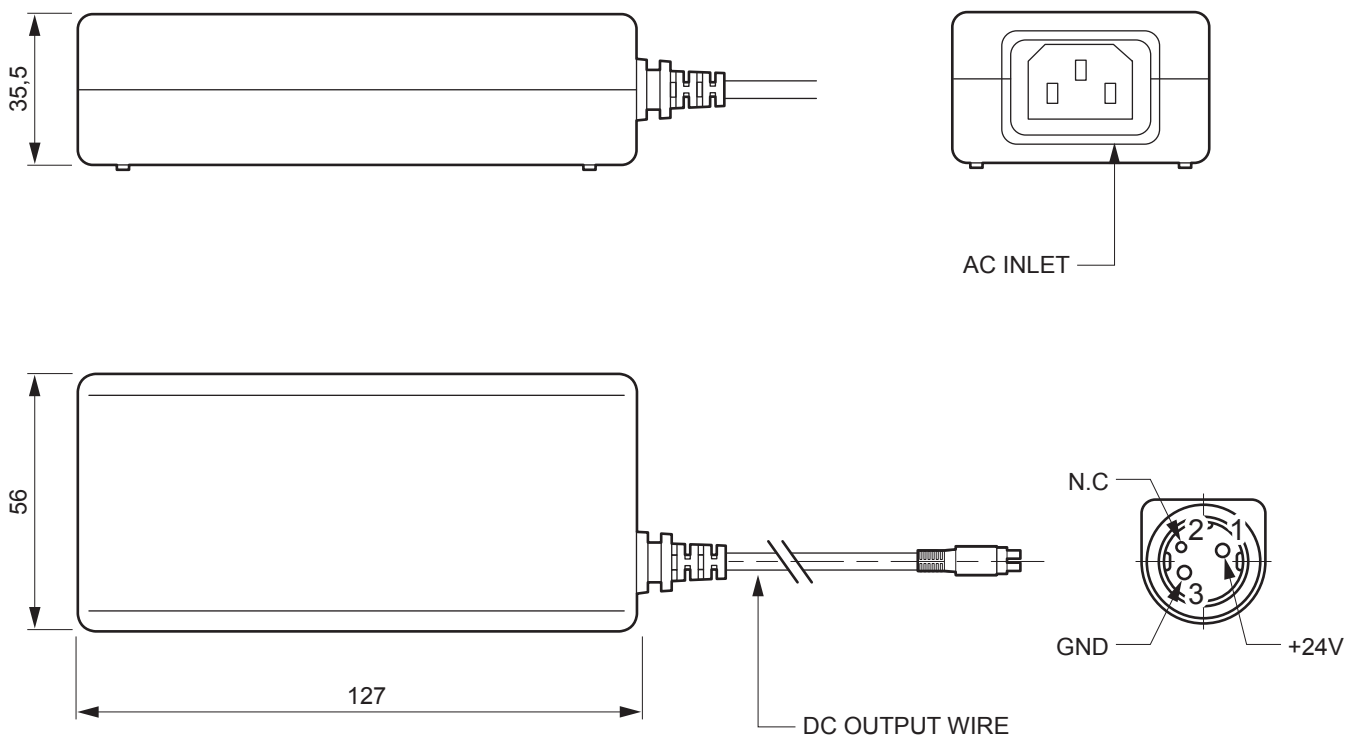

7.7 Paper specification

Paper with black mark

The following image shows the placement of the black mark on paper. The notch can be printed both on the thermal side and on the non-thermal side of paper and it can be placed anywhere on the whole width of the paper. For more information about the use of paper with black mark see Chapter 10.

NOTE:
All the dimensions shown in following figures are in millimetres.

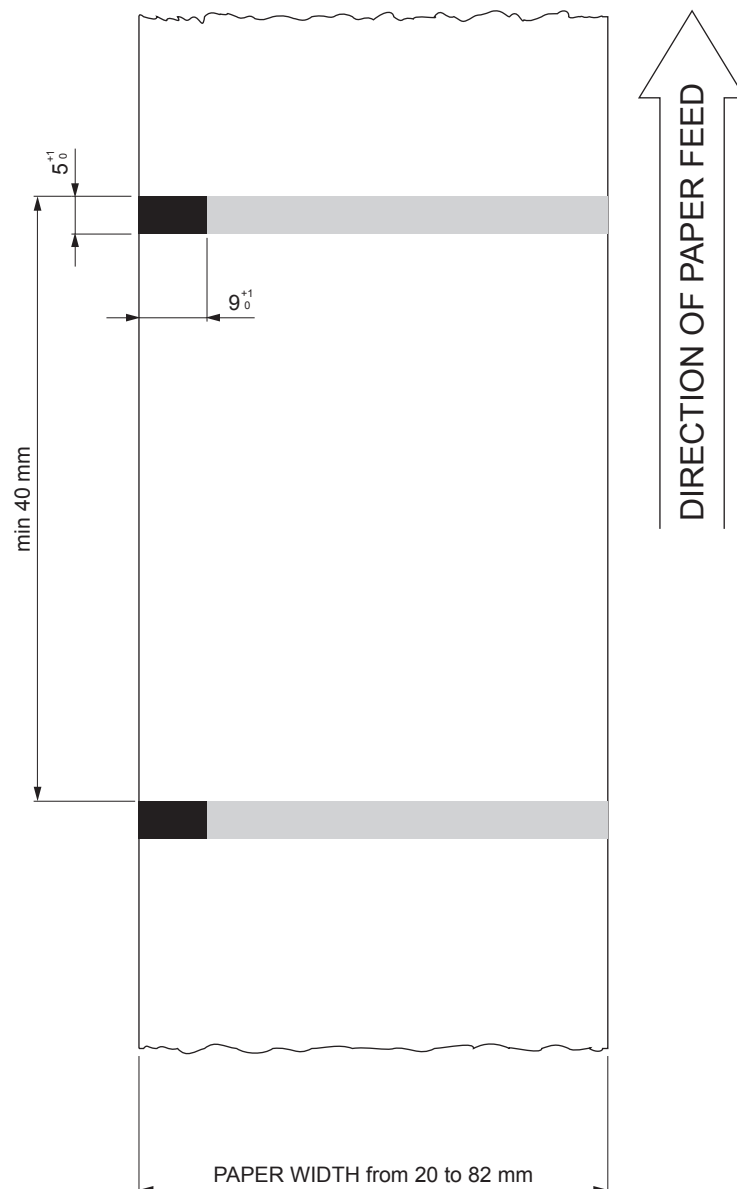

Fanfold paper with hole

The following image shows the placement of the hole on the paper. The hole can be positioned across the width of the ticket. To manage tickets with hole, set the parameter “Notch / B.Mark position” to “Transparent” (see par. 5.4). For more information about the use of paper with hole see Chapter 10.

NOTE:
All the dimensions shown in following figures are in millimetres.

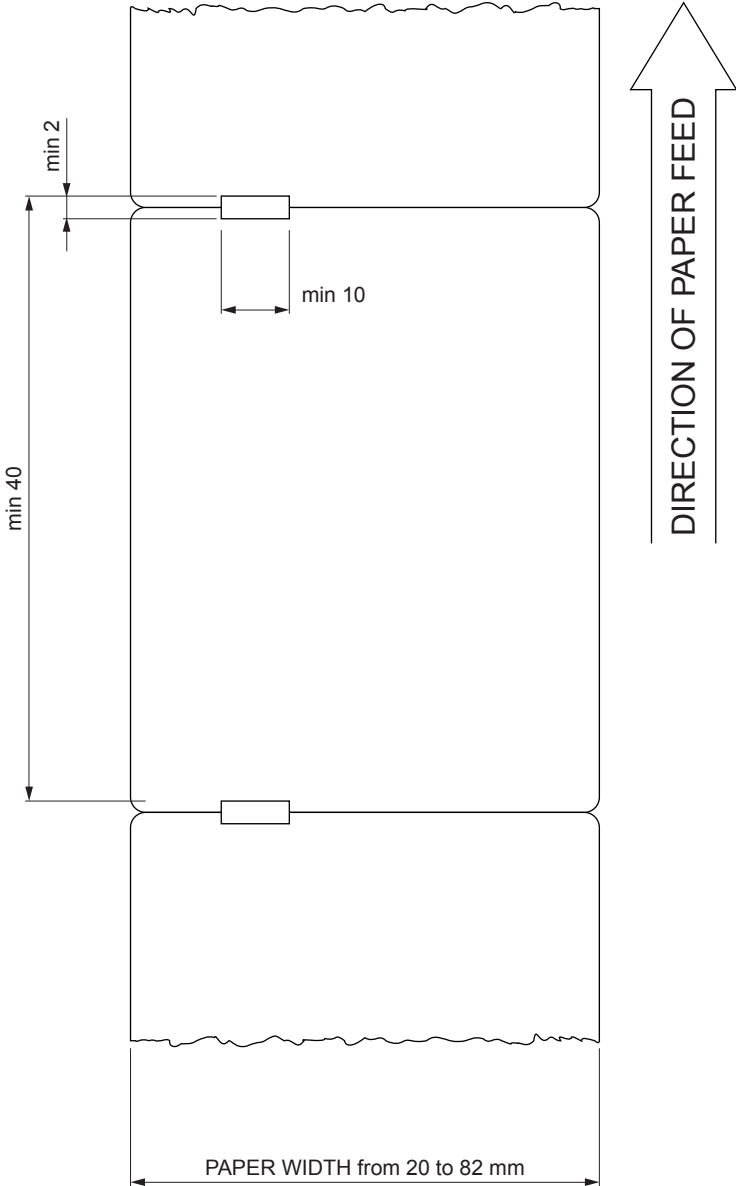

7.8 Character sets in CUSTOM/POS emulation

The device has 3 fonts of varying width (11, 15 and 20 cpi) which may be related one of the coding tables provided on the device.

To know the coding tables actually present on the device, you need to print the font test (see par.2.6).

You can set font and coding table by using the commands (see the Commands Manual of the device) or using the "Code Table" and the "Chars / Inch" parameters during the Setup procedure (see par.5.4).

The following is the full list of coding tables that can be installed on the device.

<CodeTable>	Coding table	
0	PC437 - U.S.A., Standard Europe	
1	Katakana	
2	PC850 - Multilingual	
3	PC860 - Portuguese	
4	PC863 - Canadian/French	
5	PC865 - Nordic	
11	PC851 - Greek	on request
12	PC853 - Turkish	on request
13	PC857 - Turkish	on request
14	PC737 - Greek	on request
15	ISO8859-7 - Greek	on request
16	WPC1252	
17	PC866 - Cyrillic 2	
18	PC852 - Latin 2	on request
19	PC858 for Euro symbol in position 213	
20	KU42 - Thai	on request
21	TIS11 - Thai	on request
26	TIS18 - Thai	on request
30	TCVN_3 - Vientamese	on request
31	TCVN_3 - Vientamese	on request
32	PC720 - Arabic	on request
33	WPC775 - Baltic Rim	on request

<CodeTable>	Coding table	
34	PC855 - Cyrillic	on request
35	PC861 - Icelandic	on request
36	PC862 - Hebrew	
37	PC864 - Arabic	
38	PC869 - Greek	on request
39	ISO8859-2 - Latin 2	on request
40	ISO8859-15 - Latin 9	on request
41	PC1098 - Farci	on request
42	PC1118 - Lithuanian	on request
43	PC1119 - Lithuanian	on request
44	PC1125 - Ukranian	on request
45	WPC1250 - Latin 2	
46	WPC1251 - Cyrillic	
47	WPC1253 - Greek	
48	WPC1254 - Turkish	
49	WPC1255 - Hebrew	
50	WPC1256 - Arabic	
51	WPC1257 - Baltic Rim	
52	WPC1258 - Vientamese	
53	KZ1048 - Kazakhstan	on request
255	Space page	

In CUSTOM/POS emulation, it is possible to use TrueType fonts. To be used, a TrueType font must be monospace type (every character of the font must have the same dimension). The check is made by the device when the font is selected.

TrueType fonts will be automatically scaled by the device in order to obtain the same available width for the embedded fonts (11, 15 and 20 cpi).

The quality of TrueType fonts, the correct positioning into the printable area and the available code tables, will result from the font producers and the font implementation.

For the correct printing of the code tables, it is necessary that the selected TrueType font contains all the characters in the tables. Otherwise, the '□' symbol will be printed instead the missing character. All commands for printing configuration are usable both with TrueType fonts and with embedded fonts. It is possible to address the TrueType font respects the UNICODE™ standard (see www.unicode.org), by using UTF-8 or UTF-16 encoding.

7.9 Character sets in SVELTA emulation

In SVELTA emulation, the device has 20 embedded fonts of varying width which may be accessed through control characters (see the Commands Manual of the device). The following list shows the font available and relative dimensions in dot:

- Font HEL8PT8 ^(A) Proportional Font with fixed height (H = 28 dot)
- Font HEL10PT8 ^(A) Proportional Font with fixed height (H = 34 dot)
- Font HEL14PT8 ^(A) Proportional Font with fixed height (H = 50 dot)
- Font HEL16PT8 ^(A) Proportional Font with fixed height (H = 55 dot)
- Font 18x24 (Font 18x24 in CUSTOM/POS emulation)
- Font 14x24 (Font 14x24 in CUSTOM/POS emulation)
- Font 10x24 (Font 10x24 in CUSTOM/POS emulation)
- Font 8x12 ^(B) Fixed Font
- Font 8x12-2 ^(B) Fixed Font
- Font 12x12 ^(B) Fixed Font
- Font 14x11 ^(B) Fixed Font
- Font 16x24 ^(B) Fixed Font
- Font 16x24_1 ^{(B) (C)} Fixed Font
- Font 16x24_2 ^{(B) (C)} Fixed Font
- Font 20x15 ^(B) Fixed Font
- Font 28x20 ^(B) Fixed Font
- Font 14x24_1 ^{(B) (C)} Fixed Font
- Font 16x24CN ^{(B) (C)} Fixed Font
- Font OCRB (20x32) ^(B) Fixed Font

For further information to characters representations print the Font Test ^(D).

NOTES:

- ^(A) A proportional font is a font in which different characters have different pitches (widths).
- ^(B) A fixed font is the opposite of a proportional font and is a fixed-pitch font.
- ^(C) The fonts with the same name and dimension contain different characters in different positions from theirs.
- ^(D) During power-up, if the FF FORM FEED key is held down, the device executes the FONT TEST.

In SVELTA emulation, it is possible to use TrueType fonts. True Type fonts are printable with every angle of rotation and in bold, reverse, italic and underlined mode.

It is possible to address the TrueType font respects the UNICODE™ standard (see www.unicode.org), by using UTF-8 or UTF-16 encoding.

For the correct printing of the code tables, it is necessary that the selected TrueType font contains all the characters in the tables. Otherwise, the '□' symbol will be printed instead the missing character.

8 CONSUMABLES

The following table shows the list of available consumables for device:

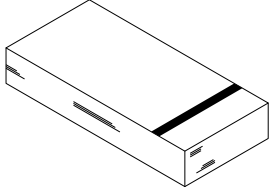
DESCRIPTION	CODE
<p>FANFOLD (100 tickets)</p> <p>weight = 140 g/m² dimensions = 152mm x 80mm</p>	<p>67A00000000304</p> 

9 ACCESSORIES

The following table shows the list of available accessories for device:

KPM180H (all models)

DESCRIPTION	CODE
-------------	------

963GE02000003

POWER SUPPLY
(for technical specifications, see the par.7.1)

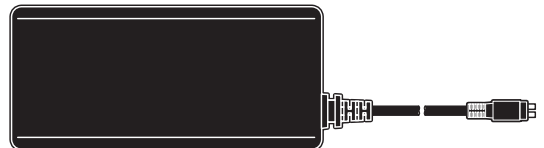

974AU010000305

PAPER ROLL HOLDER

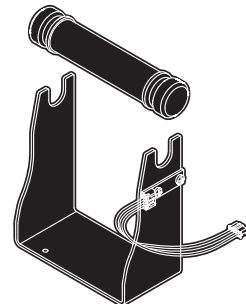

KPM180H (standard models)

DESCRIPTION	CODE
-------------	------

976AH010000001

PRESENTER MODULE + AUTOCUTTER
(for technical specifications, see the par.7.1)

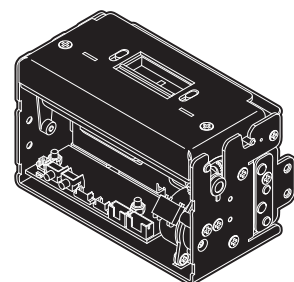

TK180 (metallic models)

DESCRIPTION	CODE
-------------	------

963GE02000003

POWER SUPPLY
(for technical specifications, see the par.7.1)



974HL01000001

PAPER ROLL HOLDER

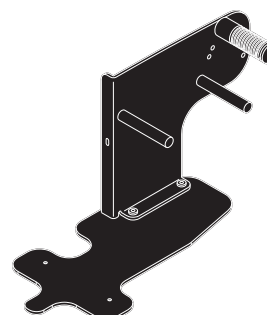

TK180 (plastic models)

DESCRIPTION	CODE
-------------	------

963GE02000003

POWER SUPPLY
(for technical specifications, see the par.7.1)



974HL02000001

PAPER ROLL HOLDER

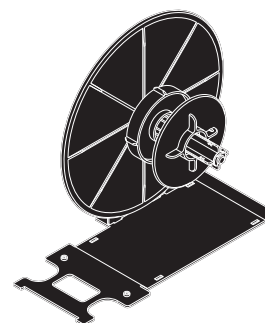

10 ALIGNMENT

Device is provided with sensors for the use of alignment notch in order to handle:

- roll of tickets with pre-printed fields and a fixed length;
- Fan-fold of tickets with pre-printed fields and a fixed length.

The alignment notch may be formed by

- black mark printed on paper (see par.7.7);
- hole between two tickets (see par.7.7);

All alignment sensors are “reflection” sensors: this kind of sensor emits a band of light and detects the quantity of light reflected to it. The presence of the notch is therefore detected by the amount of light that returns to the sensor, considering that the light is reflected by the white paper and absorbed by the black mark.

To use tickets with holes, it is possible to use the same sensors as “transparence” sensors, coupled two by two: a beam of light is emitted by the transmitter sensor and the quantity of light which reaches the opposite receiver sensor is detected. The presence of the hole is detected evaluating the amount of light that arrives to the opposite sensor, considering that the paper doesn't allow the beam of light to reach the receiver, whereas a hole lets the light to reach the receiver.

The following paragraphs show how to correctly set the configuration parameters of device in order to assure the alignment.

10.1 Enable alignment

Device is provided with two sensors for alignment, placed as follows:

- one mobile sensor on the lower flat,
- one mobile sensor on the upper flat.

To guarantee the alignment, it is necessary to correctly choose the sensor to use for the notch detection depending on the type of notch and its location on the ticket.

To do this, you must enable the parameter “Notch/B.Mark Position” during the Setup procedure (see chapter 5) and set the correct value of this parameter as described in the following table.

SENSOR USED	VALUE OF THE “NOTCH/B.MARK POSITION” PARAMETER	USING MODE OF SENSORS	NOTCH TYPE
-	Disabled	-	Alignment disabled
1	Bottom	Reflection	Black mark printed on the non-thermal side of paper
2	Top	Reflection	Black mark printed on the thermal side of paper
1 + 2	Transparent	Transparence	Hole between tickets

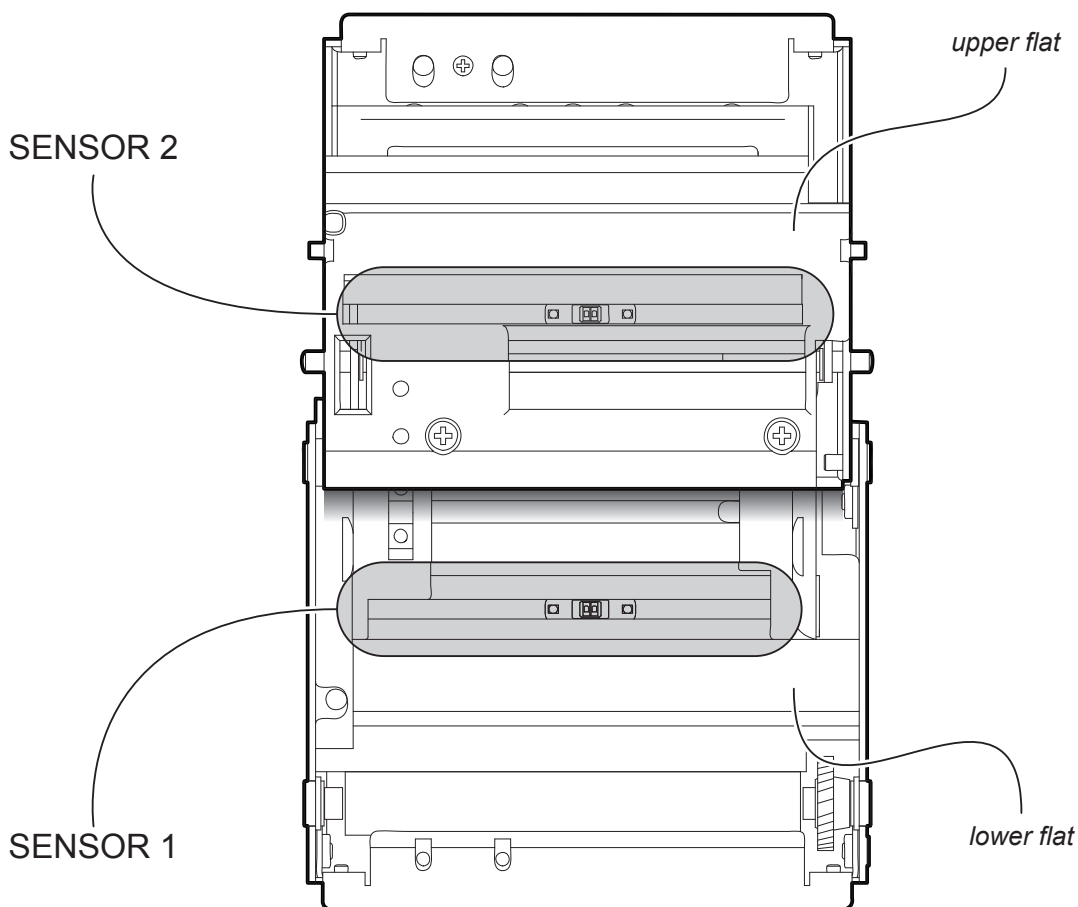

The following figures show the usable format of paper and the corresponding sensors used for alignment:

NOTE: For ease of understanding, the image shows the two flats represented in the same plane. For some models, only the internal printer group is represented.

Paper with black mark on the non-thermal side

Paper with black mark on the thermal side

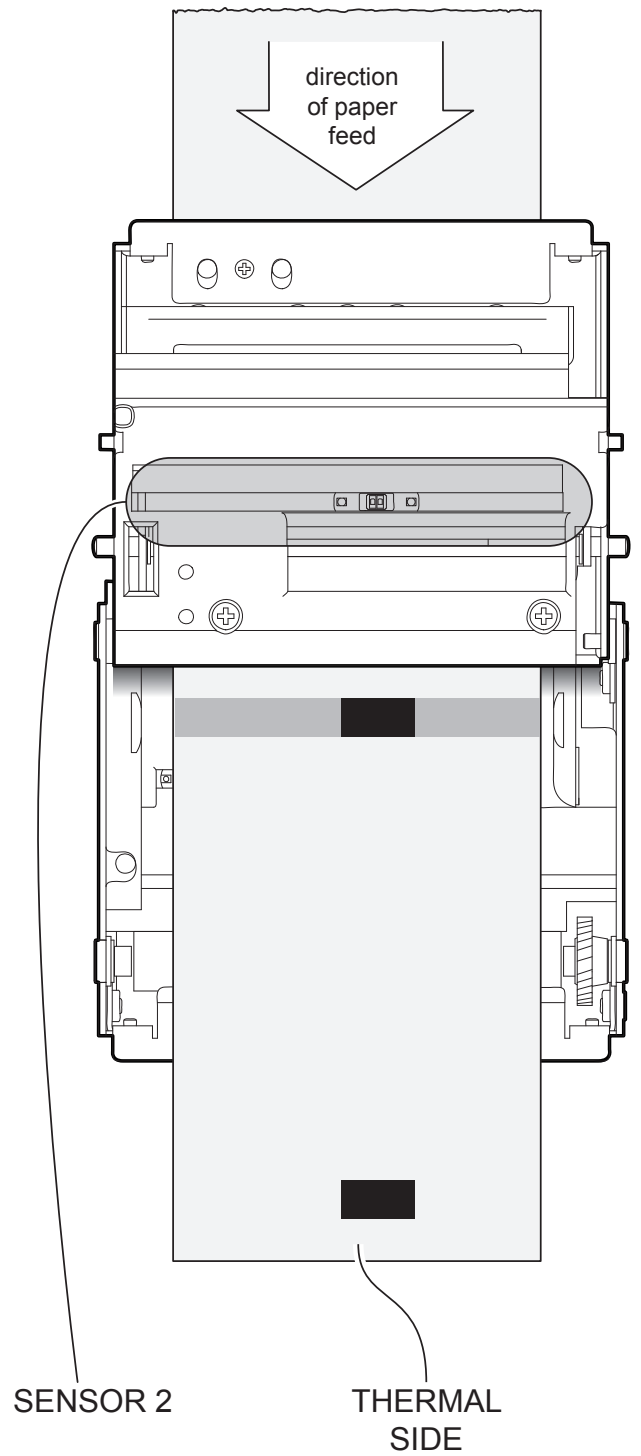
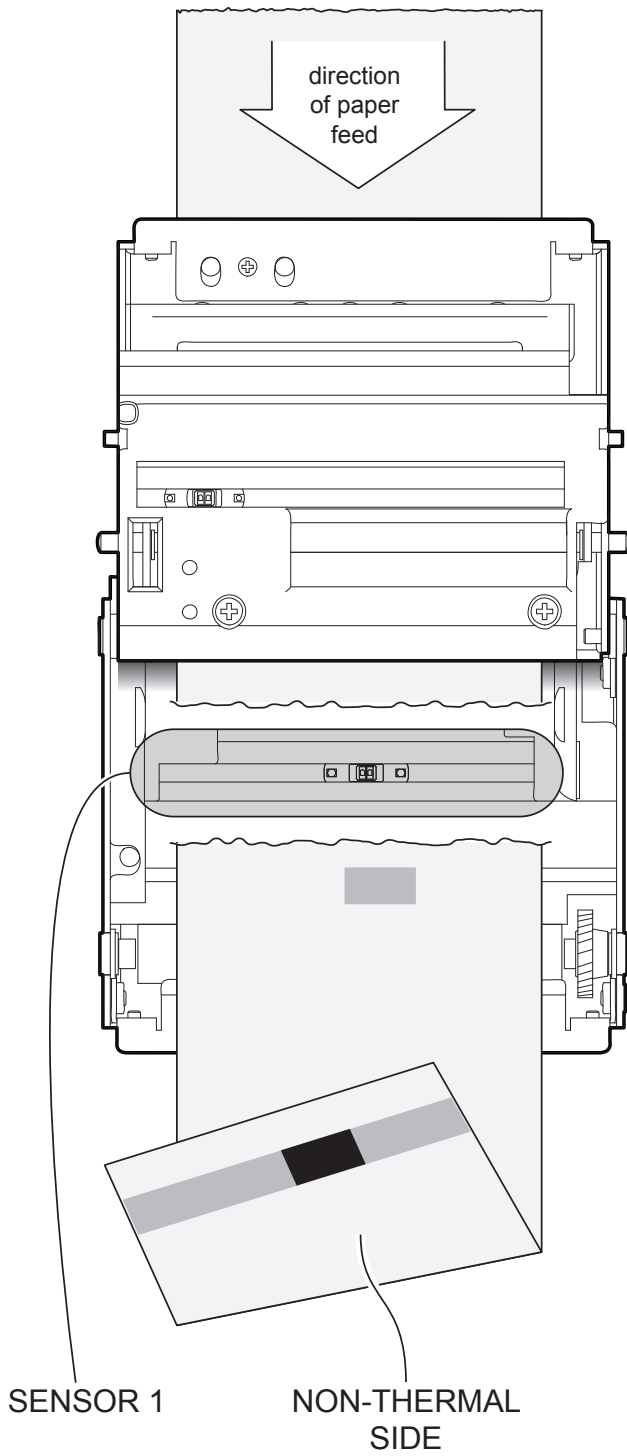

Tickets with hole

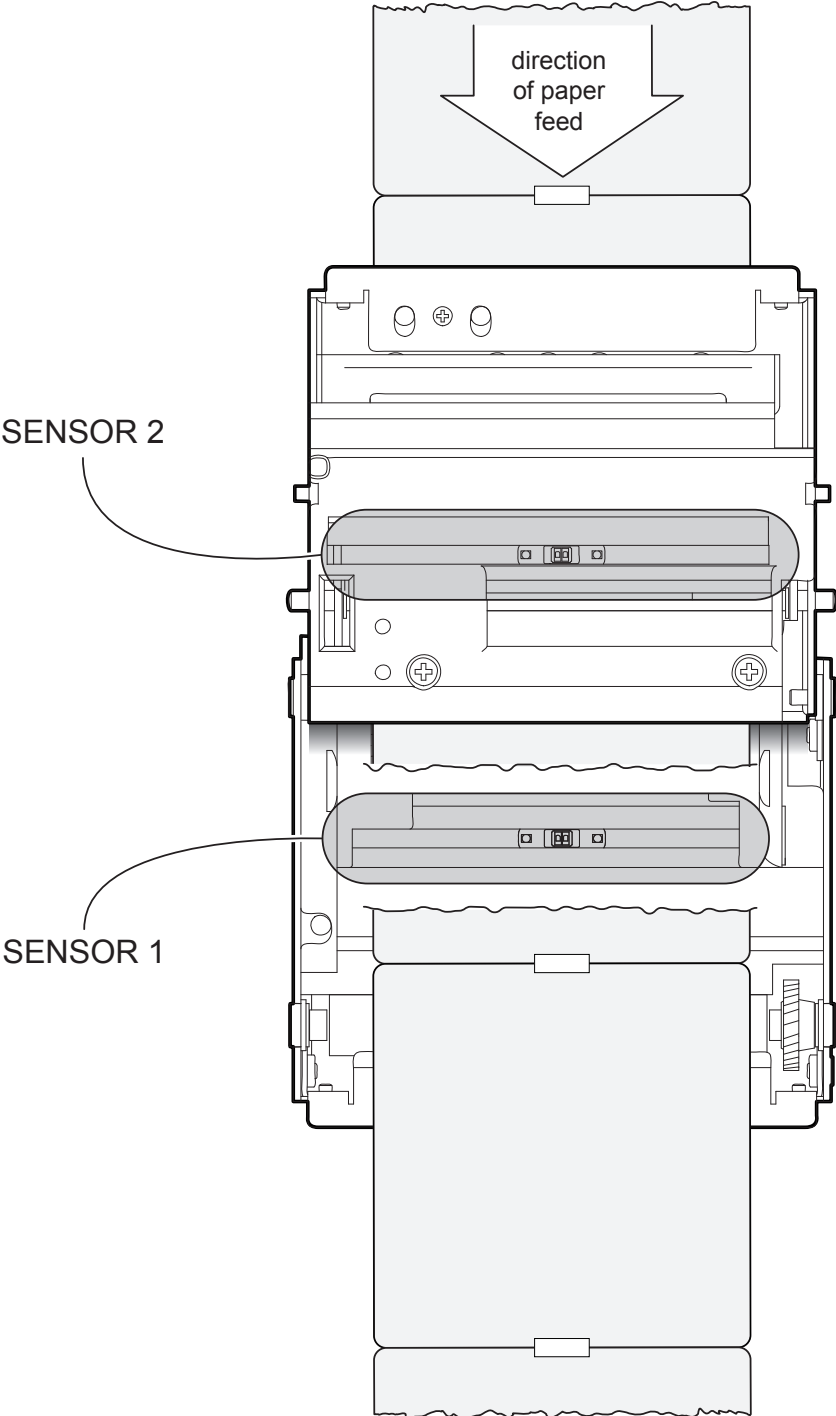

10.2 Calibration

The sensor calibration occurs automatically and consists in adjusting the quantity of light emitted to match the degree of whiteness of the paper used and the degree of black of the mark printed on paper.

The device automatically performs the self-calibration during the Setup procedure only if the “Notch/B.Mark Position” parameter is set to a value other than “Disabled” (see chapter 5).

When self-calibration starts, the device performs some paper feeds and then it prints the calibration result and the value of the PWM duty-cycle of the alignment sensor driver so that it can be perform an optimal notch detection:

Autosetting Notch : OK
PWM Duty Cycle : 85.3%

The “Autosetting Notch” parameter indicates the result of the self-calibration procedure; OK will appear if it has been successful, NOT OK will appear if the procedure has failed.

After the printing of the procedure result, the device offers the execution of the function of paper characterization “Characterize Paper” and the change of the “Notch/B.Mark Threshold” parameter which represents the detection threshold of the notch. Choosing the “Yes” value for the “Characterize Paper” parameter, the device prints a graphic representation (see following figures) of the outgoing voltage of the alignment sensor (expressed as a percentage) and the “Notch/B.Mark Threshold” value. This graphic representation is useful to set the most suitable value to assign to the “Notch/B.Mark Threshold” parameter and then to better identify the optimal threshold value which takes into account the variations of the signal and the small oscillations around zero.

The following figure shows an example of paper with the non-thermal paper printed with black marks: the outgoing voltage is constant while passing the white paper between two notches and presents a peak at each black mark. In this case, the optimal value for the “Notch/B.Mark Threshold” parameter is placed about half of the peak.

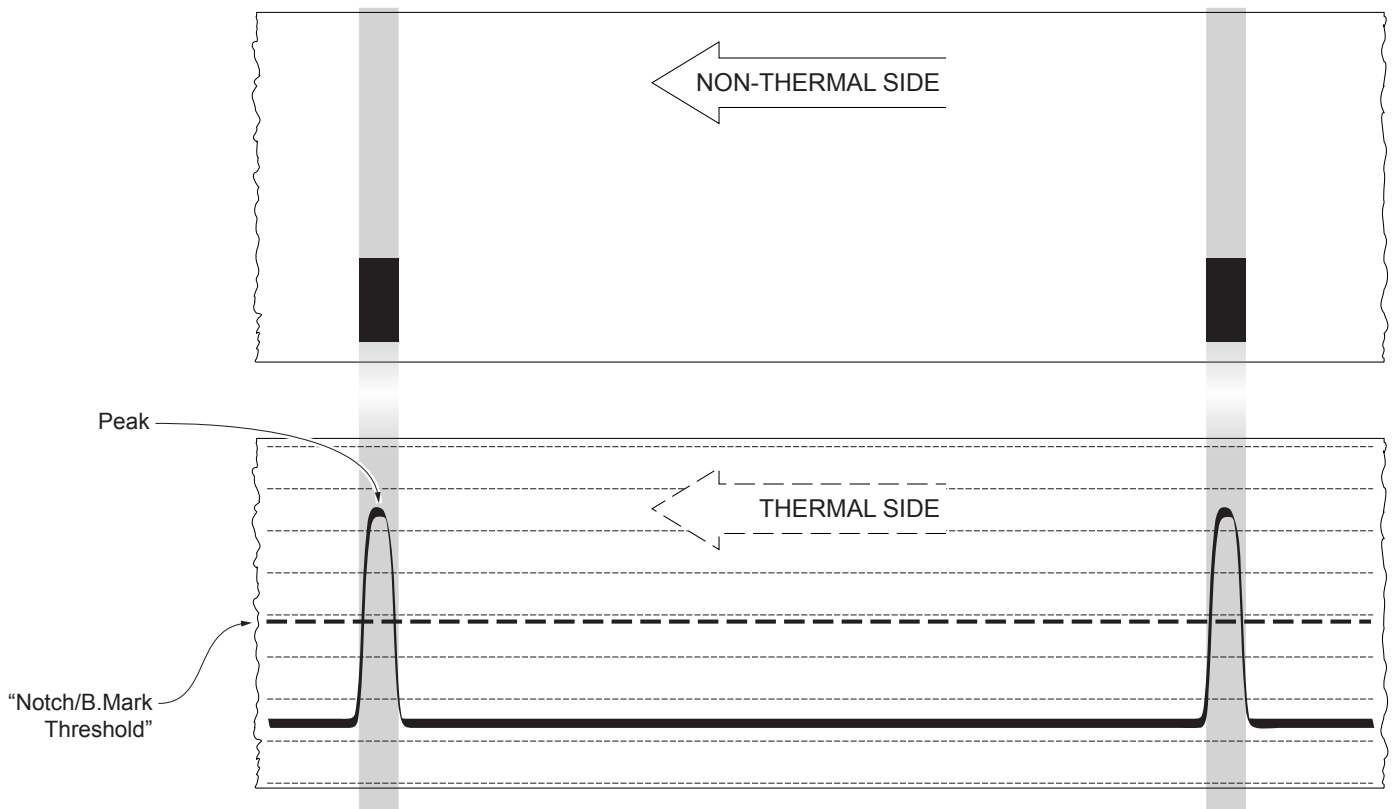

The following figure shows an example of paper with holes: the outgoing voltage is constant while passing the paper between two holes and presents a variation at each hole. In this case, the optimal value for the “Notch/B.Mark Threshold” parameter is placed about half of the variation.

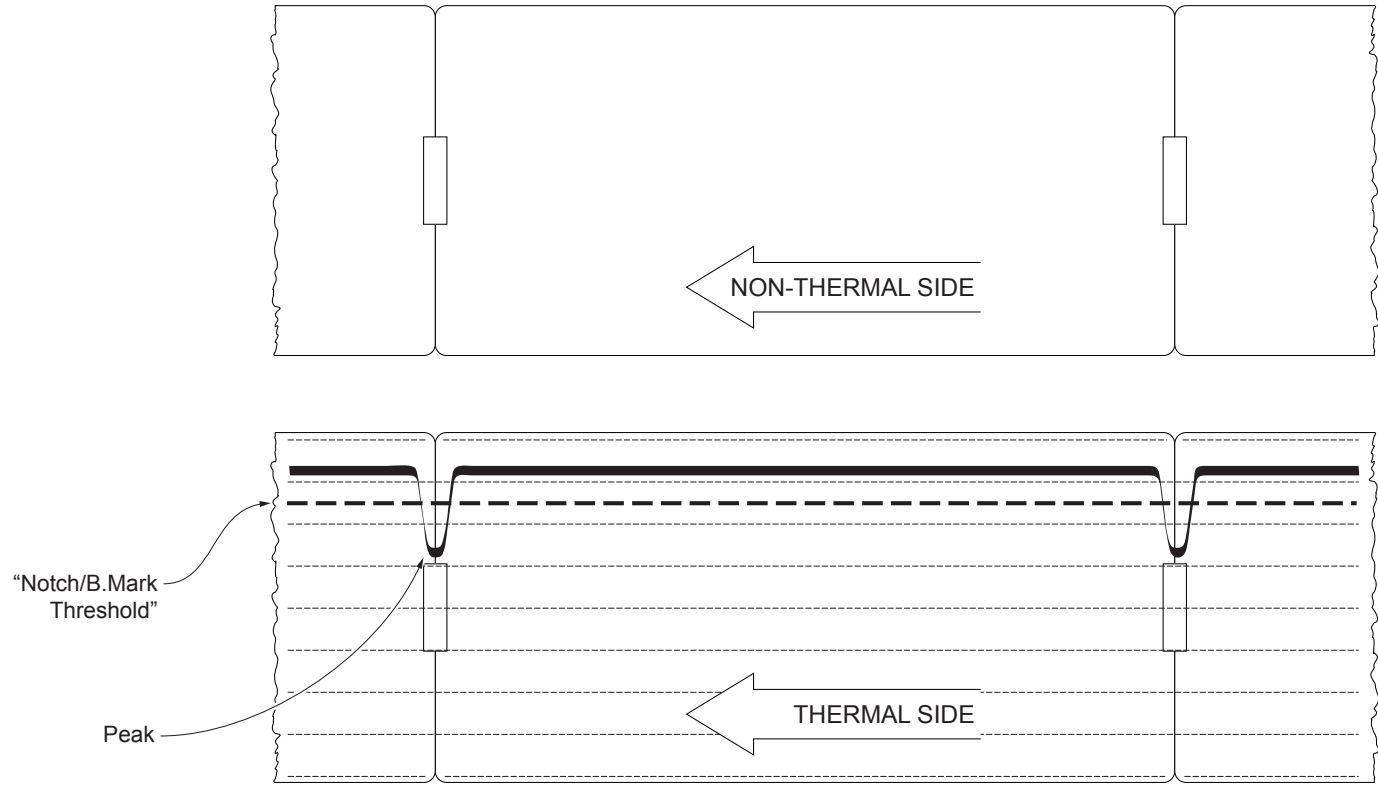

The following figure shows an example of paper with the non-thermal paper printed with black marks and other graphics (for example, a barcode): the outgoing voltage is constant while passing the white paper between two notches, presents a peak at each black mark and presents some “noise” at each barcode. In this case, the optimal value for the “Notch/B.Mark Threshold” parameter is located about halfway between the peak value and the maximum value of the “noise”.

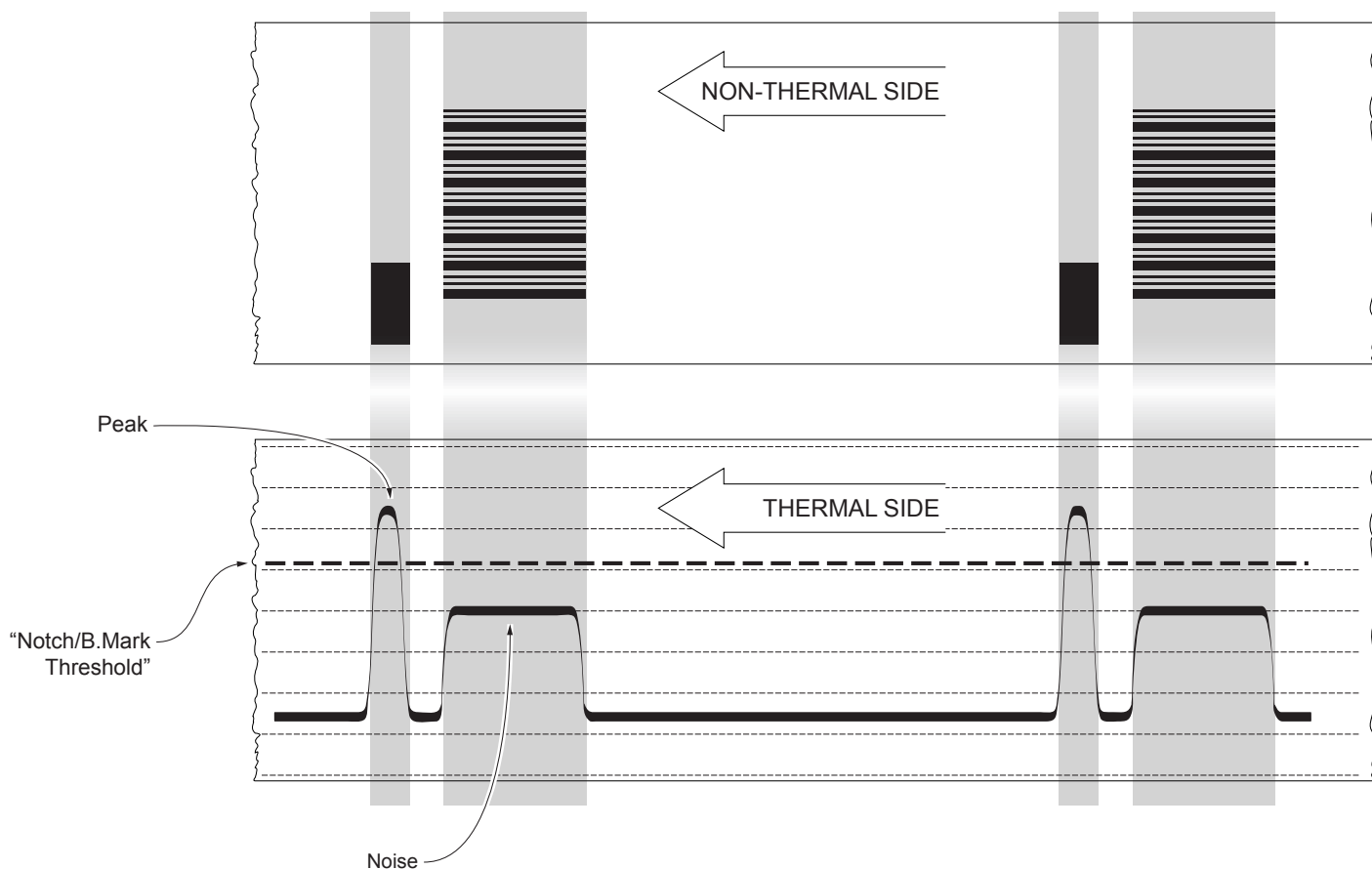

If the maximum value of “noise” read by the sensor is very close to the peak value, it might be difficult to place the value of the “Notch/B.Mark Threshold” at an intermediate point. In these cases, it is mandatory that the portion of paper between the point of printing end and the front notch is completely white (no graphics). In this way, the only next graphic detected by the sensor for alignment after the printing end will be the notch.

10.3 Alignment parameters

The “alignment point” is defined as the position inside the ticket to use for the notch alignment. The distance between the notch edge and the alignment point is defined as “Notch Distance”.

Referring to the front of the notch, the value of “Notch Distance” value varies from -5mm minimum and 99.9mm maximum.

If the “Notch Distance” value is set to 0, the alignment point is set at the beginning of the notch.

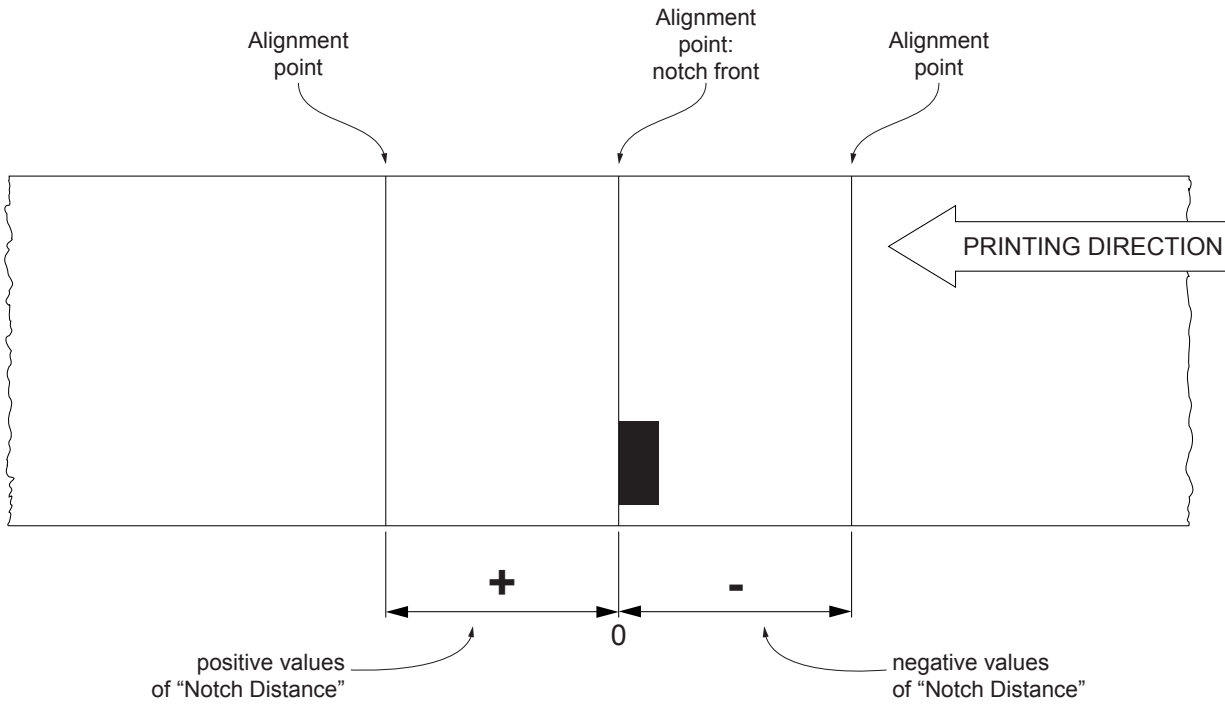

The following figure shows an example of paper with alignment point set by a positive value of “Notch Distance” (“Notch Distance” = + A):

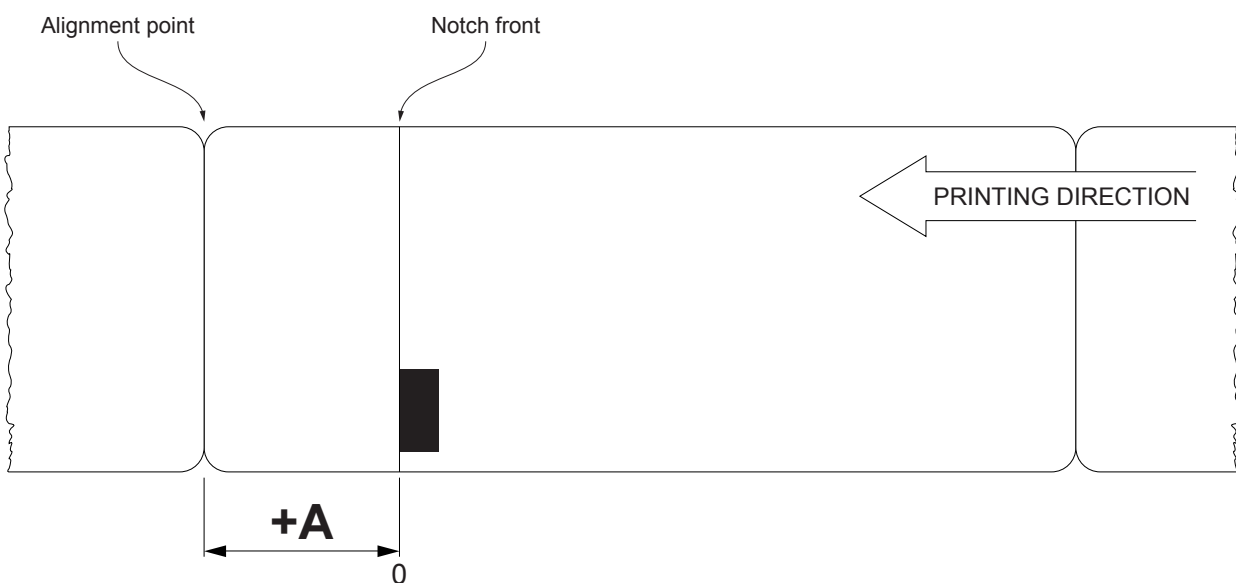

To set a negative value of the “Notch Distance” parameter is useful in cases where the alignment point refers to the notch printed on the previous ticket or where the desired cutting line is placed in the middle of the alignment notch (for example, for paper with holes or gap). In the following images, the value of “Notch Distance” parameter is set to $-A$.

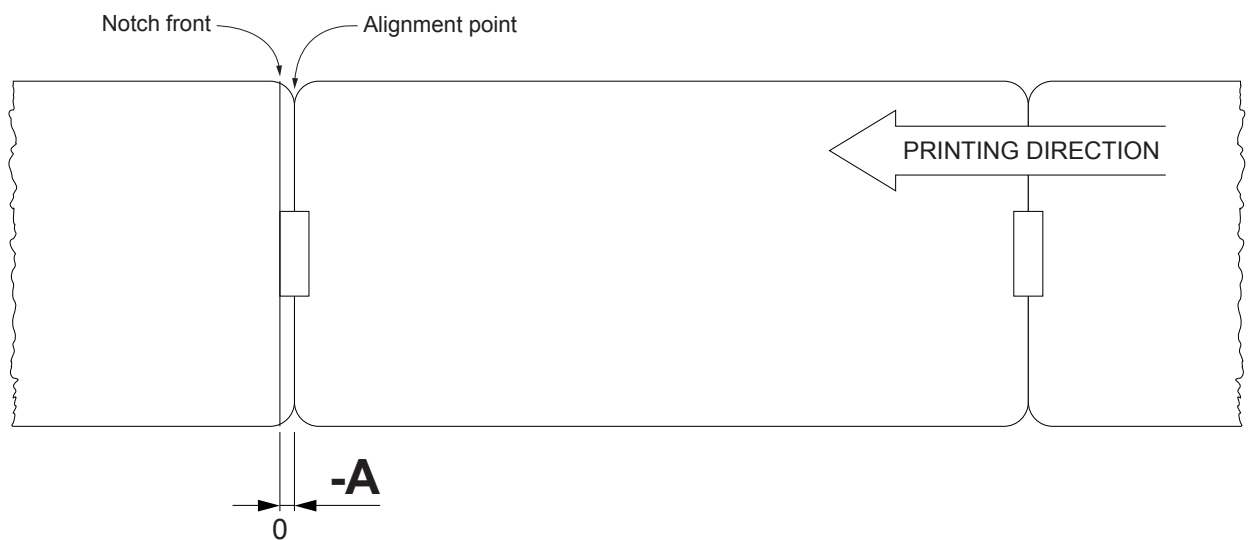
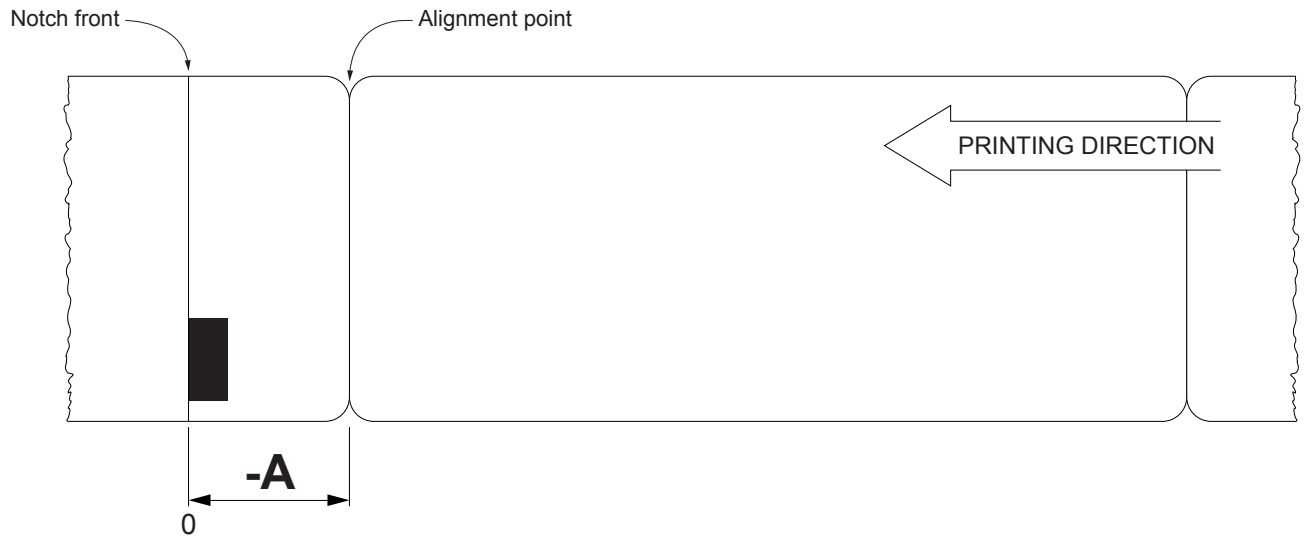

The following figures show the simplified sections of the device models with the paper path and the distances (in mm) between the alignment sensor, the print head, cutter (for models with presenter) and paper out mouth.

KPM180H (standard models), TK180

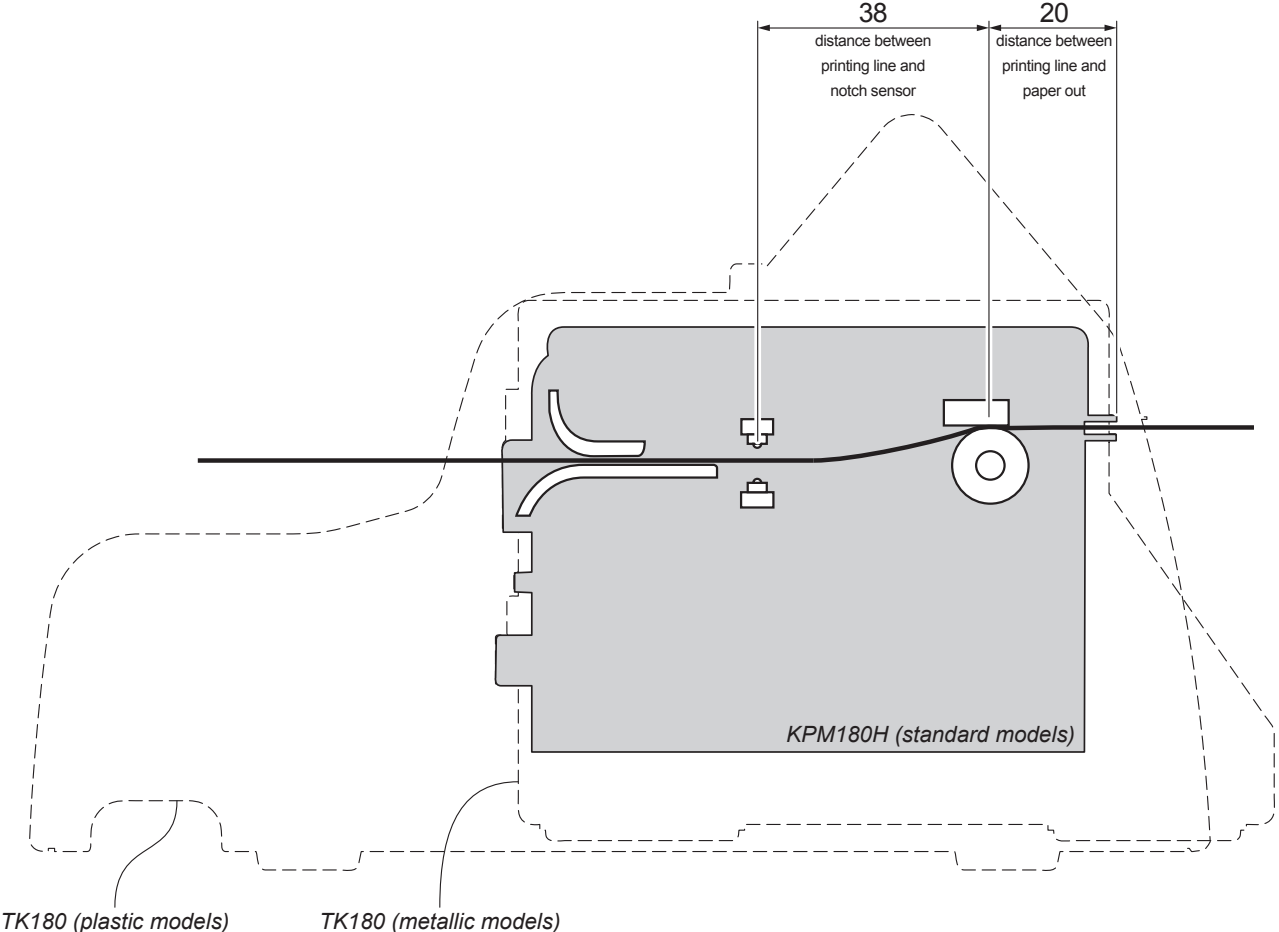

KPM180H (models with presenter)

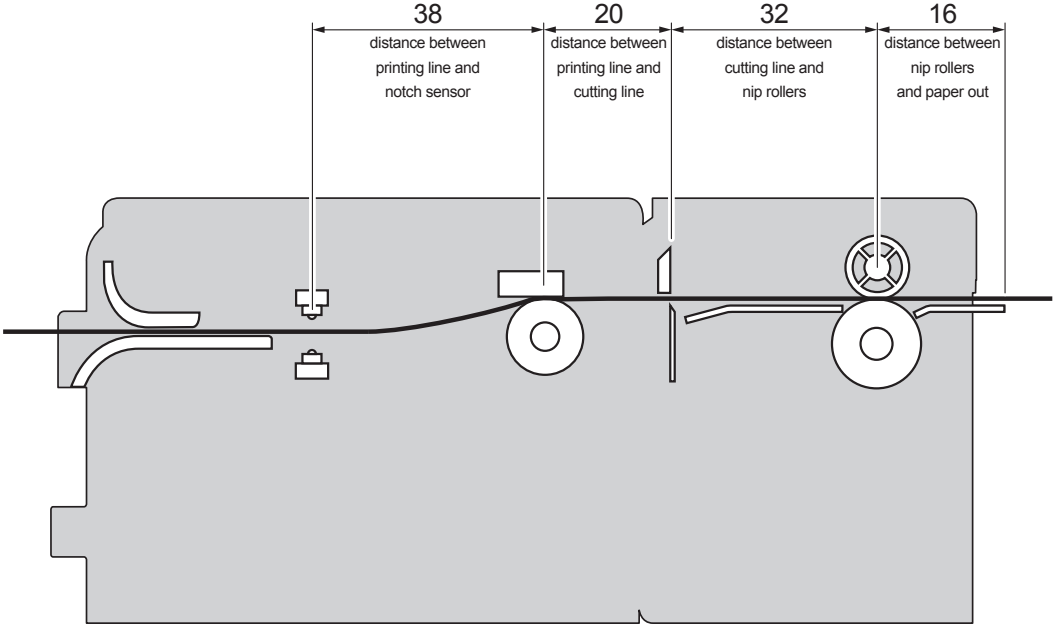

CUSTOM/POS emulation

To define the alignment point you need to set the printer parameters that compose the numerical value of the “Notch Distance” parameter. (see par.5.4).

For example, to set a notch distance of 15mm between the notch and the alignment point, the parameters must be set on the following values:

Notch Distance Sign : +
Notch Distance [mm x 10] : 1
Notch Distance [mm x 1] : 5
Notch Distance [mm x .1] : 0

The “Notch Distance” parameter, may be modified as follows:

- during the Setup procedure of the device (see chapter 5)
- by modifying the Setup.ini file (see par.12.5)
- by using the 0x1D 0xE7 command (for more details, refer to the Commands Manual)
- by driver

SVELTA emulation

The ticket features and the alignment parameters, may be modified as follows:

- by using the parameters of the <LHT> command (for more details, refer to the Commands Manual)
- by modifying the Setup.ini file (see par.12.5)
- by driver

The following figure shows the some of parameters for alignment of the Setup.ini file:

- “Ticket X Dimension”
- “Ticket Y Dimension”
- “Notch Width”
- “Notch Distance”

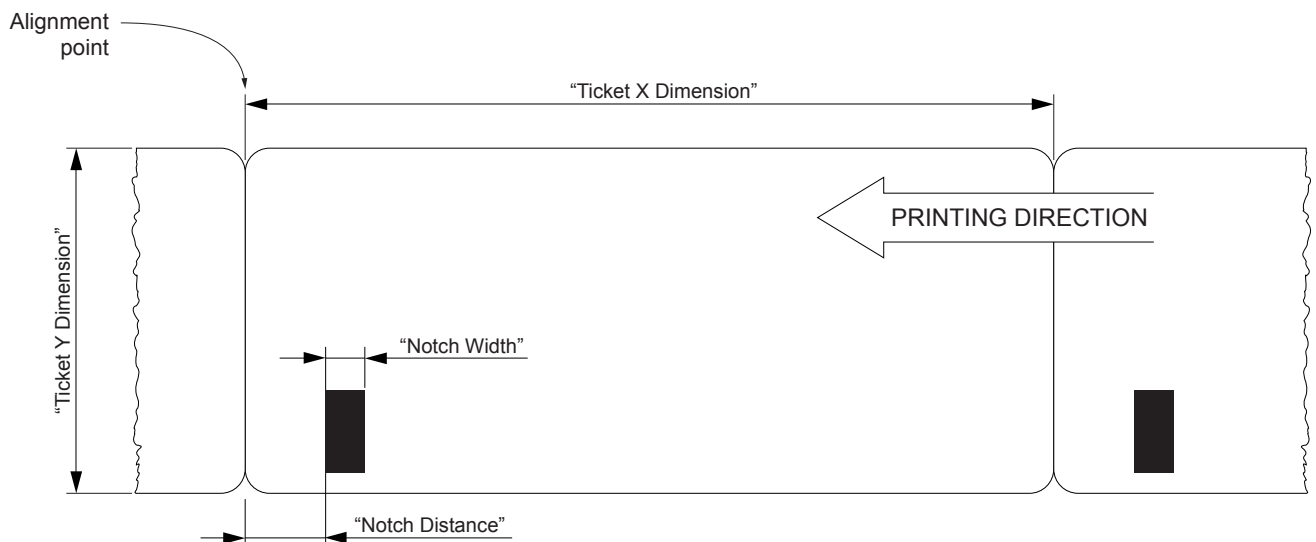

10.4 Printing area

In order to print ticket containing only one notch and to not overlay printing to a notch (that will make it useless for the next alignment), it is important to well calibrate:

- the length of the printing area of ticket according to the inter-notch distance;
- the value for the paper recovery after a cut (only for models with presenter).

KPM180H (standard models), TK180

The following figure shows an example of tickets with “Notch Distance” set to 0:

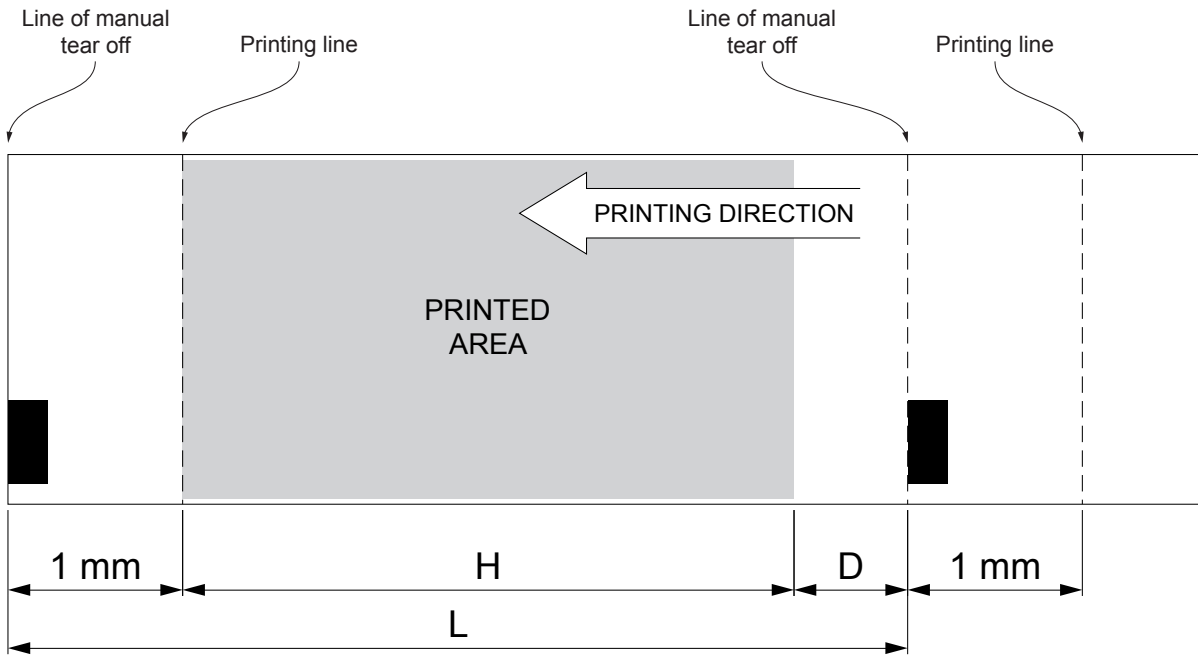

H Distance between the first and the last print line, called “Height of the printing area”.

L Distance between an edge of the notch and the next one, called “Inter-notch distance”.

D Automatic feed for alignment at the next notch.

To use all the notches on paper, you must comply with the following equation:

$$1\text{mm} + H \leq L$$

The height of the printing area (H) can be increased to make no progress on alignment (D) but no further.

KPM180H (models with presenter)

The following figure shows an example of tickets with “Notch Distance” set to 0:

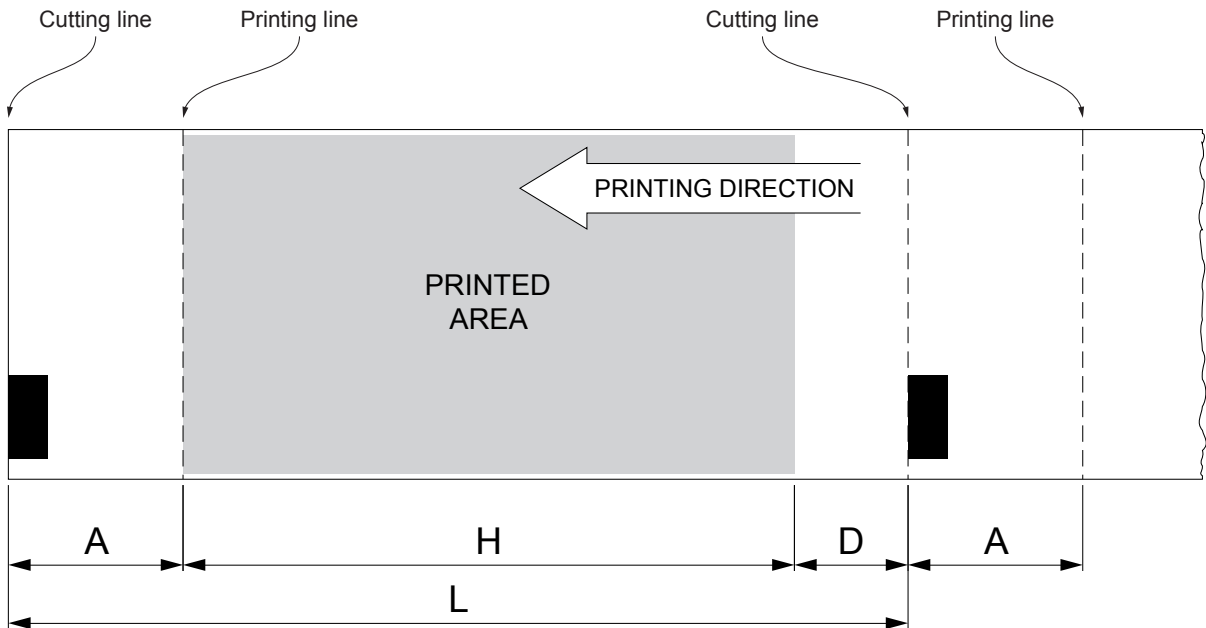

A “Non-printable area” of 1 mm generated from:

“Distance between cutter/printing head”- “Value for the paper recovery after a cut”

where:

“Distance between cutter/printing head” = 20 mm (fixed distance)

“Value for the paper recovery after a cut”= 19 mm

In CUSTOM/POS emulation use the command 0x1C 0xC1 to set the “Value for the paper recovery after a cut” (see Commands Manual).

H Distance between the first and the last print line, called “Hieght of the printing area”.

L Distance between an edge of the notch and the next one, called “Inter-notch distance”.

D Automatic feed for alignment at the next notch.

To use all the notches on paper, you must comply with the following equation:

$$H + A \leq L$$

The height of the printing area (H) can be increased to make no progress on alignment (D) but no further.

11 TECHNICAL SERVICE

In case of failure, send the 4 pieces of information listed below to our support team:

1. Product code
2. Serial number
3. Hardware release
4. Firmware release

To get the necessary data, proceed as follows:

1



Write down the data printed on the product label (see par.2.5).

2

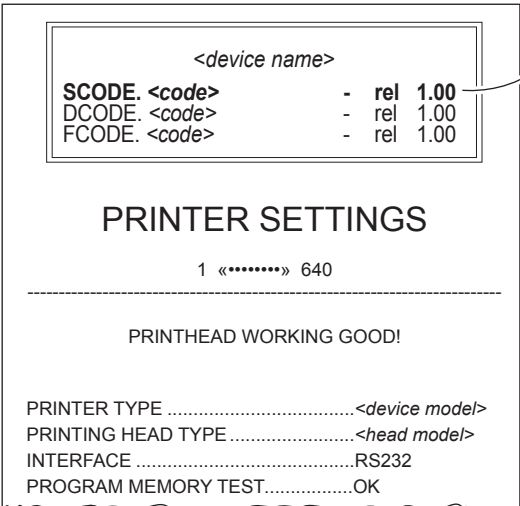

Print a Setup report (see paragraph 5.1)
The Setup report shows the firmware release.

3





Customer Service Department:

support@custom.it
 (worldwide)

or

support@customamerica.com
 (specific for North/South American customers)

Send an e-mail to the Technical Service, with the data collected.

12 ADVANCED FUNCTIONS

12.1 File sharing

The device can be connected to a PC with a USB cable.

Through this kind of connection, it is possible to manage drivers, fonts and logos of the device and configure the operating parameters by files sharing from Mass Storage.

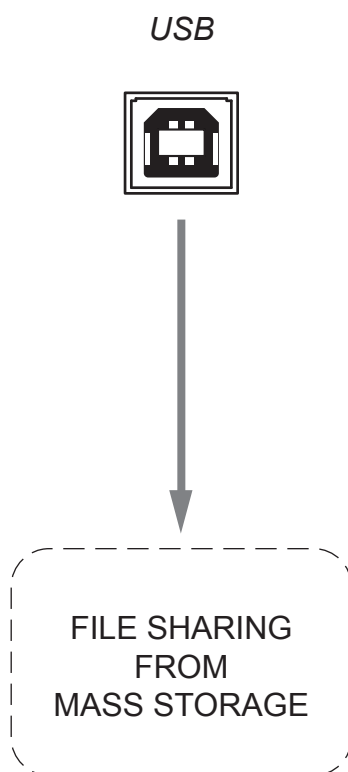

12.2 Drivers installation

TK180 (all models)

It is possible to install the new driver update directly into the folder "DRIVER" on the Flash Drive of the device.

To enter the Flash Drive by files sharing from Mass Storage you need to enable the relative parameter during the configuration process (see chapter 5).

12.3 Logos management

It is possible to store new logos in addition to default logos stored on Flash Disk. The device automatically provides to convert BMP image to the error-diffusion format in black and white.

It is possible to directly add the new logo directly into the folder “PICTURES” on the Flash Drive of the device. To enter the Flash Drive by files sharing from Mass Storage, you need to enable the relative parameter during the configuration process (see chapter 5).

After adding the logo, open the configuration file “PictList.ini” and add a new line with a number associated to the logo (to be used with device’s commands), a letter for the memory unit and the logo file name, as indicated in the instructions written inside the “PictList.ini” file.

To delete a logos stored in the device, proceed as follows:

1. delete the selected logo from the “Pictures” folder on Flash Disk;
2. in the configuration file “PictList.ini”, delete the line related to the erased logo.

The logos stored on Flash Disk and converted by the device, can be printed by using the number associated to the logo during the conversion step.

The correspondence between file-name and logo-number is warrant by the configuration file “PictList.ini” and it is verifiable with the logo test.

12.4 Fonts management

It is possible to store new font in addition to default fonts stored on Flash Disk.

You can directly add the new font directly into the folder “FONTS” on the Flash Drive of the device.

To enter the Flash Drive by files sharing from Mass Storage, you need to enable the relative parameter during the configuration process (see chapter 5).

NOTE:

Uploading the new font directly from the “Font” folder of Microsoft® Windows® directory, remember that the displayed font name into the “Font” folder may not match the real name of the font file.

12.5 Setup

It is possible to configure the default parameters for device setup by editing the "Setup.ini" file on the Flash Drive. To enter the Flash Drive by files sharing from Mass Storage, you need to enable the relative parameter during the configuration process (see chapter 5). After editing device's parameter, simply save the "Setup.ini" file to make the modifies activated.

The "Setup.ini" file is a configuration file that contains all the configurable parameters listed in text format and divided into some sections (indicated in square brackets). The available values for every parameter, are listed after the parameter name. The value marked with the symbol ' * ' is the default one. To modify printer's parameters, change the numeric value after the name of parameters. To set the parameter to the default value, change the numeric value with the symbol D.

The "Setup.ini" file permits the configuration of the following parameters:

[PRINT]

Printer Emulation	0*, 1	0 = CUSTOM/POS 1 = SVELTA		
Print Mode	0*, 1	0 = Normal 1 = Reverse		
Autofeed	0*, 1	0 = CR disabled 1 = CR enable		
Chars / inch	0, 1*, 2	0 = A=11 B=15 cpi 1 = A=15 B=20 cpi	2 = A=20 B=15 cpi	
Code Table [num]	0			
Chinese font	0*, 1	0 = Disabled 1 = Enabled		
Speed / Quality	0, 1*, 2	0 = High Quality 1 = Normal	2 = High Speed	
Paper Width	0, 1, 2, 3, 4, 5, 6, 7, 8, 9, 10, 11, 12, 13, 14, 15, 16, 17, 18, 19, 20, 21, 22, 23, 24, 25, 26, 27, 28, 29, 30, 31*	0 = 18 mm 1 = 20 mm 2 = 22 mm 3 = 24 mm 4 = 26 mm 5 = 28 mm 6 = 30 mm 7 = 32 mm 8 = 34 mm 9 = 36 mm 10 = 38 mm	11 = 40 mm 12 = 42 mm 13 = 44 mm 14 = 46 mm 15 = 48 mm 16 = 50 mm 17 = 52 mm 18 = 54 mm 19 = 56 mm 20 = 58 mm 21 = 60 mm	22 = 62 mm 23 = 64 mm 24 = 66 mm 25 = 68 mm 26 = 70 mm 27 = 72 mm 28 = 74 mm 29 = 76 mm 30 = 78 mm 31 = 80 mm
Paper Threshold	0, 1*, 2, 3, 4, 5, 6	0 = 30 % 1 = 40 % 2 = 50 %	3 = 60 % 4 = 70 % 5 = 80 %	6 = 90 %

Notch/B.Mark Position	0*, 1, 2, 3	0 = Disabled 1 = Bottom	2 = Trasparence 3 = Top	
Notch/B.Mark Threshold	0, 1*, 2, 3, 4, 5, 6	0 = 30 % 1 = 40 % 2 = 50 %	3 = 60 % 4 = 70 % 5 = 80 %	6 = 90 %
Notch Distance [mm]				
Notch/B.Mark Min.Width	0*, 1, 2, 3, 4, 5, 6, 7, 8, 9, 10, 11, 12, 13, 14, 15, 16, 17, 18, 19, 20	0 = 0 mm 1 = 1 mm 2 = 2 mm 3 = 3 mm 4 = 4 mm 5 = 5 mm 6 = 6 mm	7 = 7 mm 8 = 8 mm 9 = 9 mm 10 = 10 mm 11 = 11 mm 12 = 12 mm 13 = 13 mm	14 = 14 mm 15 = 15 mm 16 = 16 mm 17 = 17 mm 18 = 18 mm 19 = 19 mm 20 = 20 mm
Ticket Locking	0*, 1	0 = Disabled 1 = Enabled		
Ticket Management	0*, 1	0 = Disabled 1 = Check First		
Casing Type	0, 1*	0 = Metal 1 = Plastic		
PrintHead Test PowerOn	0*, 1	0 = Disabled 1 = Enabled		
Print Density	0, 1, 2, 3, 4*, 5, 6, 7, 8	0 = - 50 % 1 = - 37 % 2 = - 25 %	3 = - 12 % 4 = 0 % 5 = + 12 %	6 = + 25 % 7 = + 37 % 8 = + 50 %

[INTERFACE]

RS232 Baud Rate	1, 2, 3, 4, 5, 6, 7, 8*	1 = 1200 bps 2 = 2400 bps 3 = 4800 bps	4 = 9600 bps 5 = 19200 bps 6 = 38400 bps	7 = 57600 bps 8 = 115200 bps
RS232 Data Length	0*, 1	0 = 8 bits/chr 1 = 7 bits/chr		
RS232 Parity	0*, 1, 2	0 = None 1 = Even	2 = Odd	
RS232 Handshaking	0, 1*	0 = Xon/Xoff 1 = Hardware		

Busy Condition	0*, 1	0 = RxFull 1 = OffLine/RxFull		
USB Virtual COM	0*, 1	0 = Disabled 1 = Enabled		
USB Mass Storage	0*, 1	0 = Disabled 1 = Enabled		
USB Address Number	0*, 1, 2, 3, 4, 5, 6, 7, 8, 9	0 = 0 1 = 1 2 = 2 3 = 3	4 = 4 5 = 5 6 = 6 7 = 7	8 = 8 9 = 9

[SVELTA]

Ticket X Dimension

Ticket Y Dimension

Notch Distance

Notch Width

Barcode timeout

[NETWORK] (only for models with ETHERNET port)

DHCP Client	0*, 1	0 = Disabled 1 = Enabled
-------------	-------	-----------------------------

IP Address

Subnet Mask

Default Gateway

Domain Name System

TCP Printer Port

MAC Address

CUSTOM[®]

CUSTOM S.p.A.

World Headquarters

Via Berettine, 2/B - 43010 Fontevivo, Parma ITALY

Tel. +39 0521 680111 - Fax +39 0521 610701

info@custom.biz - www.custom.biz

All rights reserved