

USER MANUAL

Digital 'Interference Free' Wireless Range

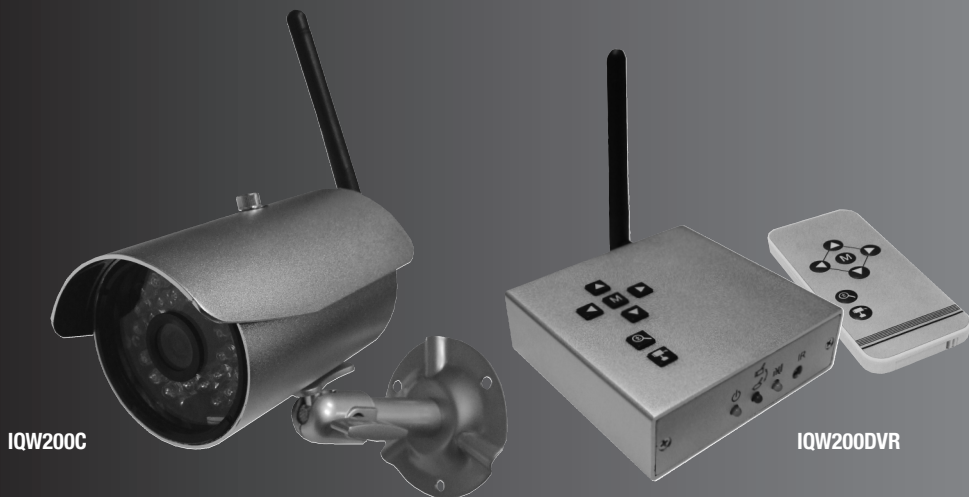

Before you begin

- Before the product is installed, please read the operation manual carefully.
- Please unpack all boxes carefully and identify that all the parts are present.
- Make sure you use only the recommended power supplies. Damage caused to the camera or receiver by incorrect voltage or wiring is not covered by the warranty.
- Cutting any cable will void the warranty.
- Do not drop, pierce or dismantle the camera or receiver.

PLEASE NOTE: Camera and Receiver units are sold separately.

RoHS
Compliant



IQW200C / IQW200DVR

IQW200C – Digital 'Interference Free' Wireless Camera

IQW200DVR – Digital 'Interference Free' Receiver & USB DVR

Index

1	PRODUCT DESCRIPTION	3
2	FEATURES	3
3	CAMERA CONTENTS	4
4	CAMERA PARTS	4
5	RECEIVER/DVR CONTENTS	5
6	RECEIVER/DVR PARTS	5
7	INSTALLATION & SETUP	6
2	8 BASIC OPERATION	7
	9 ADVANCED MENU FUNCTIONS	9
	10 USB CONNECTION TO PC	13
	11 TROUBLESHOOTING	14
	12 SPECIFICATIONS	15

1. Product Description

The IQW200 Wireless range consists of a Receiver/DVR unit which can receive video and audio from up to 4 Wireless Cameras. The Cameras work by transferring compressed video and audio data digitally via a 2Mb narrow bandwidth which offers a more efficient, secure and 'Interference Free' Wireless connection to the Receiver/DVR unit. This method of transferring images and audio eliminates the need for running cables from the cameras to the receiver and ensures installation is quick and easy.

The Receiver/DVR unit is supplied with DVR Software which will allow the unit to be connected via USB connection to a compatible Windows PC for wireless recording of up to 4 cameras on the PC.

2. Features

CAMERA FEATURES

- Offers High Resolution 420 TVL images in light levels of 0.9 lux and above
- 4.0mm Lens for a wide viewing angle of 64°
- Features IR LEDs for up to 10 metres Night Vision
- Includes a Microphone for Audio
- Unique 'Interference Free' design prevents picture quality interference associated with older analogue wireless systems by reducing the picture speed (fps) to maintain picture quality and eliminate interference.
- Designed for Wall Mounting
- Suitable for Internal or External use

RECEIVER/DVR FEATURES

- Can receive wireless signals from up to 200 metres away (in open space), through walls and ceilings the range will be 50 to 100 metres..
- Pairing function to eliminate interference and for easy camera setup.
- On Screen Display for easy selection of functions using the Menu interface.
- Allows up to 4 cameras to be auto switched or shown as Quad image
- Digital Zoom for easy viewing of areas of interest.
- Remote Control.
- AV or USB connection for viewing camera(s) on a TV/CCTV monitor (or recording to DVR) or on a PC.
- Supplied with DVR Software for wireless recording of up to 4 cameras on a Windows PC.

PLEASE NOTE: Camera and Receiver units are sold separately.

3. Camera Contents

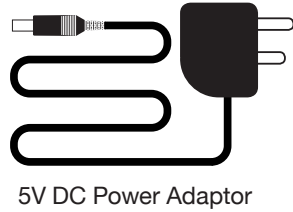
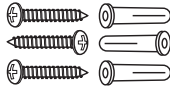
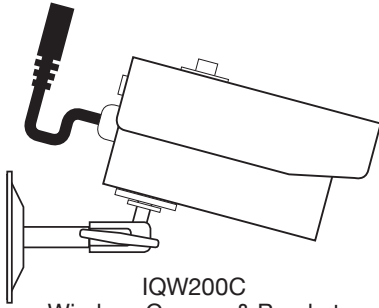

4

4. Camera Parts

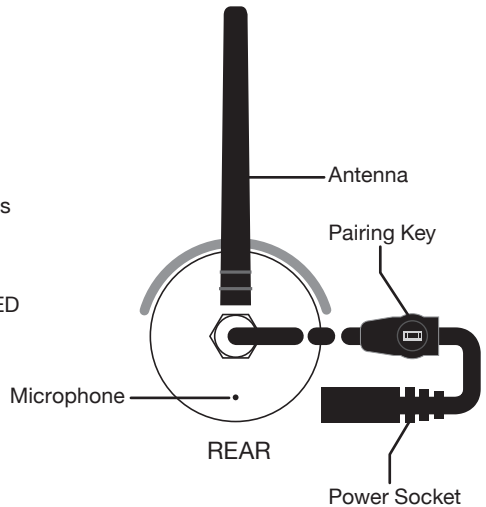
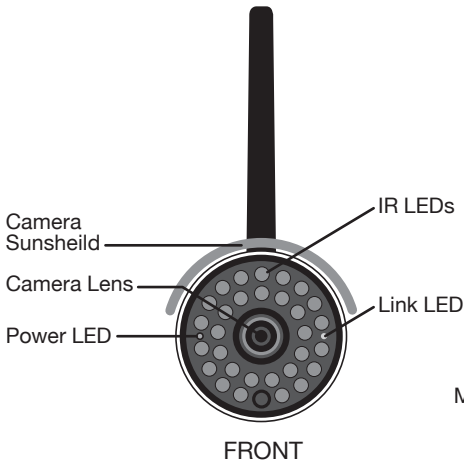

5. Receiver/DVR Contents

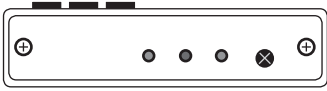

IQW200DVR
Receiver & DVR



Antenna

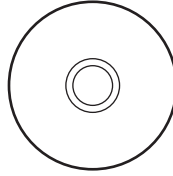

DVR Software
Installation CD

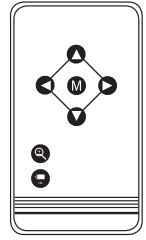

Remote Control

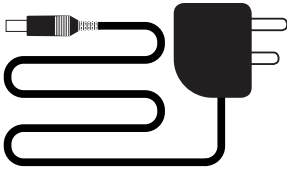

5V DC Power Adaptor

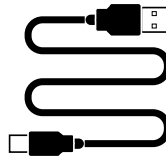

USB to USB Cable

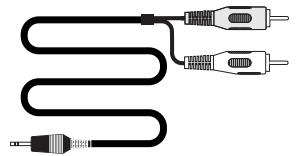

Headphone to Phono
Cable

5

6. Receiver/DVR Parts

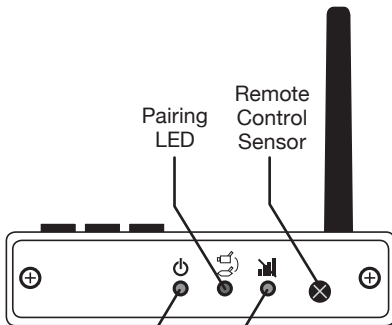

FRONT

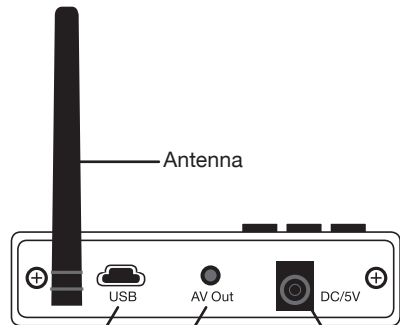

REAR

7. Installation & Setup

This section describes setting up a Wireless Camera and Receiver system to a TV.

SET UP CAMERA

1. Find a suitable place to mount the camera and fix the bracket to the wall by using the wall plugs and screws supplied
2. Loosen the thumb screw and secure the camera body to the bracket.
3. Screw on the Antenna to the rear of the camera.
4. Connect the power adaptor to the camera and plug into the mains power supply. The RED Power LED will light up. The Camera is now ready to use.

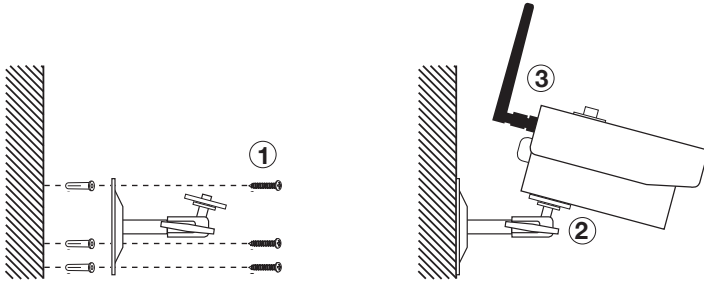

6

SET UP RECEIVER/DVR TO A TV

5. Turn on TV and switch to AV Mode
6. Connect AV cable's Audio and Video plug into the TV AV IN socket (Yellow = Video, White = Audio). To connect the receiver to a Scart socket an optional Scart to Phono Socket adaptor is required.
7. Connect the AV cable's Headphone plug into the Receiver/DVR AV OUT socket.
8. Connect the power adaptor into the Receiver/DVR DC IN socket & plug into the mains power supply. The Receiver/DVR is now ready to use.

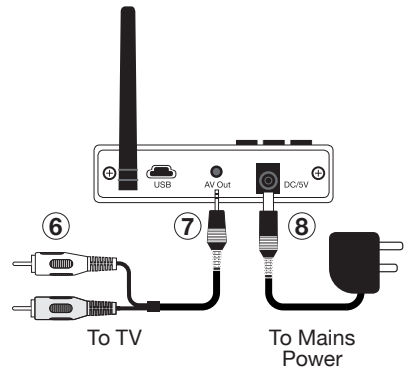

NOTE: Do not power up the Receiver/DVR using the USB Cable.

WIRELESS INDICATION

When the Camera and Receiver/DVR are connected and have a good wireless signal, the Green LED indicator on the camera and the Green Signal LED on the Receiver/DVR will light up.

8. Basic Operation

RECEIVER/DVR FUNCTION BUTTONS

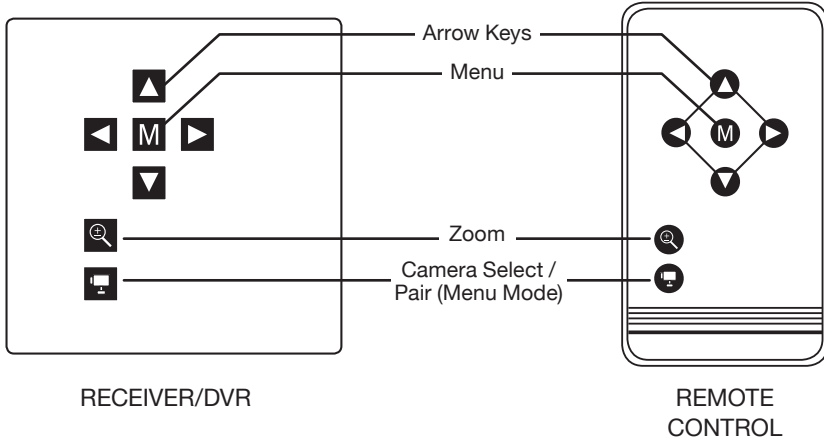

- **Arrow Keys** [Up, Down, Left, Right]

- In Zoom Mode - Pan/Tilt the camera image
- In Menu Mode - Move between the selection

- **Menu**

- Enter/Exit Menu Mode

- **Zoom** [Zoom In, Zoom Out]

- Zoom In (QVGA size - 320 × 240 resolution)
- Zoom Out (VGA size - 640 × 480 resolution)

- **Camera Select/Pair**

- In Zoom Mode - Pan/Tilt the camera image
- In Viewing Mode - manually select amongst the available camera channels
- In Menu Mode - assign and pair wireless cameras to the specified channel.

VIEW MODE

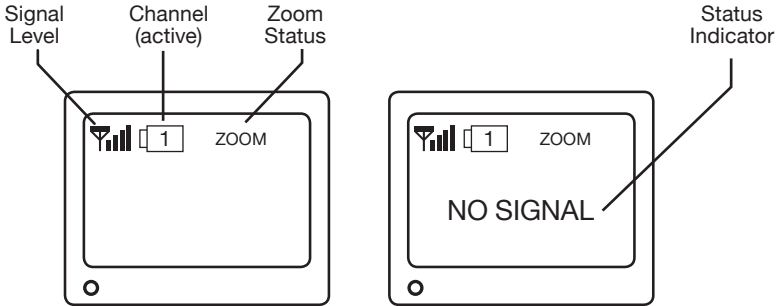

- **Signal Level** - Shows the Signal strength as follows:

Signal Level	Indicator	Data Rate	VGA (640 × 480 resolution) Frame Rate	QVGA (320 × 240 resolution) Frame Rate
Perfect		1062~1280Kbps	5~10 fps	15~25 fps
Good		725~1262Kbps	3~5 fps	12~20 fps
Fair		534~725Kbps	2~4 fps	8~15 fps
Low		250~534Kbps	0~1 fps	0~4 fps
Zero		0~250Kbps	0 fps	0 fps

- **Channel** - Shows the current camera being picked up by the Receiver/DVR.
 - By pressing you can manually switch between the available cameras in the system OR set up Auto Scan in the Menu Mode.
- **System Message (No Signal)** - Indicates Service is out of Range. Refer to Troubleshooting.
- **Zoom** - Shows the current Zoom status.

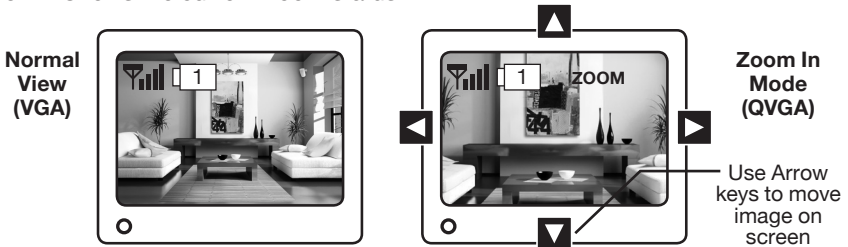

- By pressing on the Receiver/DVR you can manually switch between two resolutions.
- In Zoom mode, you can also Pan/Tilt the camera image using the arrow keys.

9. Advanced Menu Functions

Audio Vol	10
Scan Time	OFF
Camera 1	ON
Camera 2	ON
Camera 3	ON
Camera 4	ON
Pair Cam	1 2 3 4
Reset	

MENU FUNCTIONS

- By pressing **M** on the Receiver/DVR or Remote Control you can Enter or Exit Menu Mode
- Use the **◀**, **▶**, **▲** and **▼** keys to select the Menu and change their settings

● Audio [0~20]

- Use the **◀** and **▶** keys to change the volume level

● Scan Time [OFF, 5 sec, 10 sec, 15 sec, QUAD]

For setting the Auto Scan/Manual Scan Sequence for a multi camera system. The Auto Scan feature will automatically flick through the available paired camera images as set in the Menu.

Note:

The default setting is OFF

The Scan Time settings will automatically turn OFF every time the **⏏** (Camera Select button) is pressed for manual selection of cameras.





Before setting the Scan Time, ensure ALL available cameras within the system are paired to assigned channels. (See Pairing Cameras for details).

- Use the **◀** and **▶** keys to change Scan Time interval
- To skip certain channels within the sequence, simply set the camera as OFF in the Scan Time Menu as shown below:

Audio Vol	10
Scan Time	5 Sec
Camera 1	ON
Camera 2	OFF
Camera 3	ON
Camera 4	OFF
Pair Cam	1 2 3 4
Reset	



This setting will switch the camera between channels 1 and 3, every 5 seconds.

- To display the camera images as a QUAD display, set the Scan Time to QUAD. Ensure all the channels are set to ON for the display to show properly as a split screen.
- In Quad Mode, you can use the , ,  and  keys to go to a specific channel:

 = Channel 1

 = Channel 2

 = Channel 3

 = Channel 4

Audio Vol	5 Sec
Scan Time	QUAD
Camera 1	ON
Camera 2	ON
Camera 3	ON
Camera 4	ON
Pair Cam	1 2 3 4
Reset	

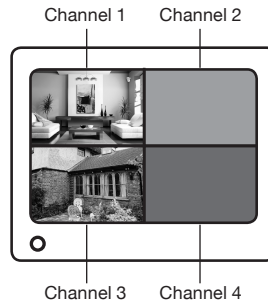

10

Note:

In Quad Mode, Speaker will be mute and Zoom and Pair button functions will be disabled

Unavailable channels will be shown as a blank screen

The Quad display will default to a one camera display every time the  (Camera Select button) is pressed for the manual selection of cameras.

Before setting the Scan Time, ensure ALL available cameras within the system are paired to assigned channels. (See Pairing Cameras for details).

● **Pair Cam ('Pairing' Cameras)**

This is used to link selected wireless cameras to the Receiver/DVR unit. We recommend you pair the cameras before any Auto Scanning is set and before the Receiver/DVR is connected to a PC.

- In the Menu, select the channel to be assigned.

Audio Vol	10
Scan Time	OFF
Camera 1	ON
Camera 2	ON
Camera 3	ON
Camera 4	ON
Pair Cam	1 2 3 4
Reset	

→ This shows how a camera is paired with Channel 3

- Press the  (Pair button). A 60 second count down will appear on screen.



- Within 60 seconds, press the Pairing Key located on the power cable of the camera.

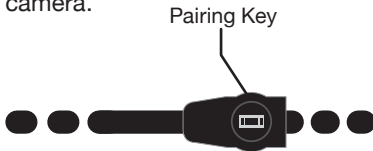

- Once Pairing is complete the screen will indicate the selected channel is active & the Receiver/DVR unit's Red Pairing LED will light up.

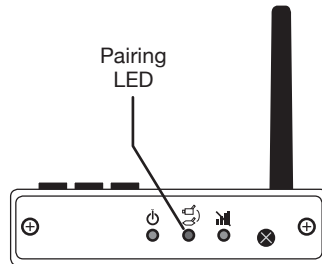
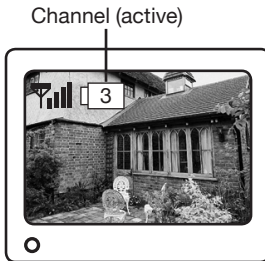

- **Reset**

- Select 'Reset' in Menu Mode
- Press the  (Pair button) to restore factory settings.

10. USB Connection to PC

This section describes setting up the Receiver/DVR to a PC to enable the recording of up to 4 channels in the wireless system.

1. Install the DVR Software provided with the Receiver/DVR unit
2. Restart the PC after installation
3. Connect the Receiver/DVR to the PC by FIRST connecting it to the PC's USB port using the USB Cable provided
4. THEN plug in the 5V DC power adaptor.
5. Launch the Guarding Software. Once connected, the system control will switch from the unit to the PC.

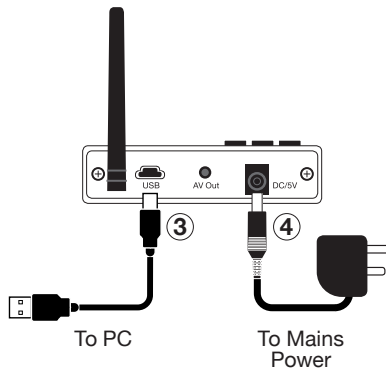

NOTE: Refer to the DVR Software Instructions (on the Installation CD) for Recording instructions and functions available with the Receiver/DVR unit.

11. Troubleshooting

Problem	Possible Causes	Solution
System Message shows 'No Signal'	No power supply connected to corresponding camera(s)	Identify the channel number to find the corresponding camera. If the power status (Red LED light) is OFF, check the power adaptor and cable connection.
	Channel is not paired with the camera.	Identify the corresponding camera and bring the camera near the receiver and pair the camera to the desired channel. See Pairing Camera(s) for details. Once pairing is complete, the Green LED status indicator will light up.
	Service is out of range	Bring the camera near the receiver.
	Signal has been blocked	If possible, remove major obstacles between the camera and receiver. Alternatively relocate the camera location.
	Camera antenna connection loss	Secure antenna to the camera body
Poor or unstable signal	Limited antenna direction	Adjust camera antenna and receiver position
	Signal has been blocked	If possible, remove major obstacles between the camera and receiver. Alternatively relocate the camera location.
	Strong radio signal nearby	Keep any WiFi routers away from the camera and receiver
	Strong electromagnetic interference near by	Keep working motors (hair dryers, fan heaters, air conditioners etc) or microwave ovens away from the camera and/or receiver.
Channel(s) disappear during Auto/Manual Scan or Quad display.	Scan channel(s) have been set to OFF.	Go to Menu and enable the channel(s). See Scan Time function (Advanced Menu Functions).
Dim or Over-bright images at night time	Low light vision distance too short / too far	Ideal low light vision distance is from 3 to 8 metres. Adjust the camera view to fit this distance.
Blank TV Screen only shows 'USB PC Camera Mode' Receiver function buttons do not respond.	USB Cable is connected	When connecting to a TV, always use 5V power adaptor to power up the receiver. Leave the USB cable unplugged <u>prior</u> to TV connection.

12. Specifications

Model:	Camera
Image Sensor	1/4" Digital CMOS
Image Resolution	420 TVL
Image Compression	MJPEG
Lens	3.6mm
Angle of View	60°
Min. Illumination	0.9 Lux
Night Vision	Up to 10 metres
Audio	Yes
Mounting	Wall/Ceiling - Internal or External use
Operating Voltage	5V DC 650mA Max.
Power Requirements	5V DC 1000mA (supplied)
Dimensions	120 x 71 x 68mm

Model:	Receiver/DVR
Maximum Channels	4
Communication Range	200 metres in open space
Compression	MJPEG
Max Recording Resolution/Speed	640 x 480 resolution at 5-10 fps* 320 x 240 resolution at 15-25 fps*
Mounting	Free Standing
Remote Control	Yes
Operating Voltage	5V DC 300mA Max.
Power Requirements	5V DC 1000mA (supplied)
Power Input	DC Socket
Audio/Video Output	AV Output (Phono Plugs) to TV USB Socket to PC
Dimensions	85 x 81 x 27mm

Minimum System Requirement for DVR Software: 1GHz or faster Processor, Microsoft Windows OS (XP or Vista), 1GB of RAM, 1.0GB Hard Drive space (minimum), Colour Monitor with 16-bit colour Video Card, 1024 x 768 monitor resolution, Microsoft DirectX 9 compatible display driver, USB Port 1.1 or above.

*Recording Speed dependant on wireless connection quality.

TECHNICAL SUPPORT:

For Technical Support please contact your local distributor.

LIMITED WARRANTY:

This product is supplied with a 1 Year warranty. The Warranty excludes products that have been misused, (including accidental damage) and damage caused by normal wear and tear. In the unlikely event that you encounter a problem with this product, it should be returned to the place of purchase.