

USER'S MANUAL AND INSTALLATION

10 and 12 SEER

Single Package Air Conditioner

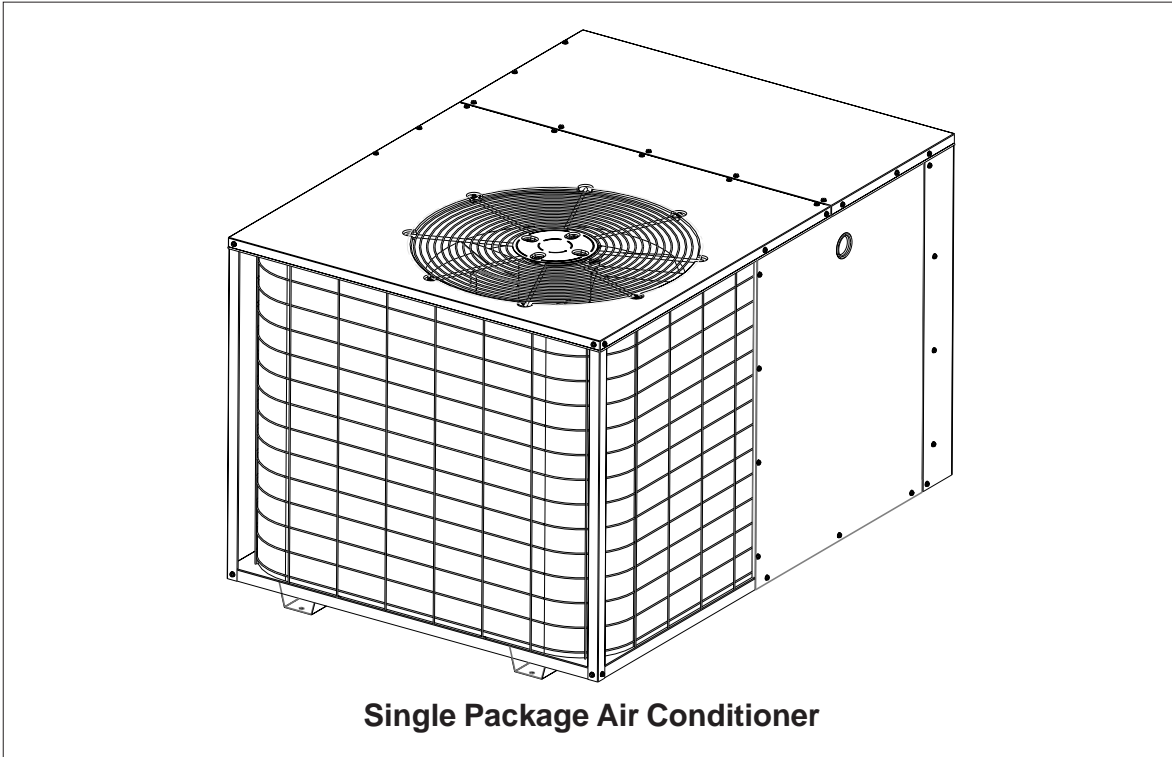

IMPORTANT

Read this owner information to become familiar with the capabilities and use of your appliance. Keep this with literature on other appliances where you have easy access to it in the future. If a problem occurs, check the instructions and follow recommendations given. If these suggestions don't eliminate your problem, call your installing contractor or distributor in your area.

INTRODUCTION

Most any air conditioner will keep you cool. Our air conditioner was designed to do it efficiently. Efficiency means less cost to you while keeping you comfortable.

WHY YOUR AIR CONDITIONER WORKS SO WELL, SO QUIETLY

1. Air is cooled by a large evaporator coil. Moisture is also removed from the air by this same coil.
2. Air is then delivered through the main duct, via registers, into your home.
3. Return air is drawn through the return register.
4. This air enters the unit, passes through the evaporator coil, is cooled and dehumidified. Then the cycle begins again.

SECTION 1. OWNER INFORMATION

OPERATING INSTRUCTIONS

To Turn On Air Conditioner

If you have a heating/cooling thermostat:

1. Set the system switch to "Cool."
2. Set the thermostat at the temperature level you desire.
3. Turn the power on. Your air conditioner should start as soon as room temperature rises above the setting on the thermostat.

If you have one thermostat for heating and another for cooling, they must be interlocked to prevent simultaneous operation (See Figure 1):

1. Turn the heating thermostat to its lowest possible setting.
2. If the cooling thermostat has an "On/Off" switch, turn it "On."
3. Set the cooling thermostat to the desired temperature.
4. Turn the power on. Your air conditioner should start when room temperature exceeds the thermostat setting.

To Shut Off Air Conditioner

If you have a heating/cooling thermostat:

1. Turn the system switch to "Heat" or "Off."
2. Turn the thermostat to the desired heating temperature setting.
3. If you are turning your air conditioner off for the winter or an extended period, shut off the power to the air conditioner.

If you have one thermostat for heating and another for cooling, they must be interlocked to prevent simultaneous operation (See Figure 1):

1. Turn your cooling thermostat "Off" or to its highest setting.
2. Turn the heating thermostat to the desired temperature.
3. If you are turning your air conditioner off for the winter or an extended period, shut off the power to the air conditioner.

BEFORE YOU CALL A SERVICEMAN

Let your serviceman check your system at the start of each air conditioning season. He will make sure it's working right, clean or change filters and make any needed adjustments.

In addition, follow these simple rules:

1. Never run your system without filter. If you do, the cooling coils will get dirty and may become clogged.
2. Set your thermostat at the comfort level you wish -- and then leave it alone. Let it control the operation of the air conditioning system. If you get chilly, turn it up a degree at a time until comfort is restored.
3. It takes longer for an air conditioner to cool your dwelling than it does for your furnace to heat it. So . . . don't turn the unit on and expect a dramatic drop in temperature, at least not right away. If your home is hot and humid, the temperature will drop slowly.
4. Check your filters every ten days in summer to see if they are dirty. To keep them clean, use a mild solution of detergent and water on washable types. Replace non washable filters.
5. Keep your outdoor condenser coil clean. You can hose it down when it gets dirty.

If your air conditioner isn't working:

1. Make sure the fuses are not blown or that your circuit breakers are on.
2. See that your thermostat is set at the desired temperature and that your system's switch is on "Cool."
3. For free air flow, make sure your return register is not covered and that the filter is clean.
4. Check the outdoor condenser coil and make sure it is clean and not clogged with grass or leaves.

If your air conditioner still isn't working, call your nearest distributor.

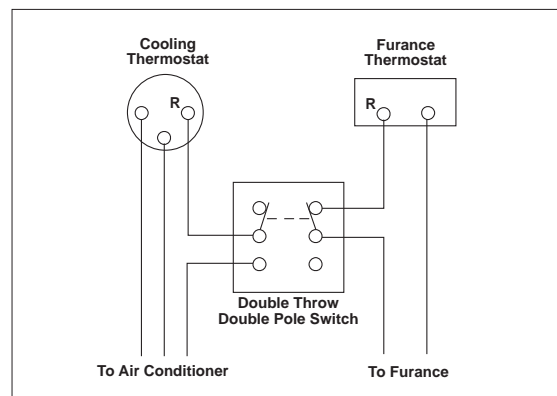

Figure 1. Thermostat Interlock System

SECTION 2. INSTALLER INFORMATION

GENERAL

Read the following instructions completely before performing the installation.

These instructions are for the use of qualified personnel specially trained and experienced in the installation of this type of equipment and related system components. Some states require installation and service personnel to be licensed. Unqualified individuals should not attempt to interpret these instructions or install this equipment.

The single packaged air conditioners are designed for outdoor installation only and can be readily connected into the high static duct system of a home. The only connections needed for installation are the supply and return ducts, the line voltage, and thermostat wiring. A complete air conditioning system typically consists of:

- Single Package Air Conditioner
- Home Fittings Kit
- Unit Fittings Kit
- Thermostat

The single package air conditioner is completely assembled, factory wired, and factory run tested. The units are ready for easy and immediate installation.

PRE-INSTALLATION CHECK

Before any installation is attempted, the cooling load of the area to be conditioned must be calculated and a system of the proper capacity selected. It is recommended that the area to be conditioned be completely insulated and vapor sealed.

The installer should comply with all local codes and regulations which govern the installation of this type of equipment. Local codes and regulations take precedence over any recommendations contained in these instructions. Consult local building codes and the National Electrical Code (ANSI C1) for special installation requirements.

The electrical supply should be checked to determine if adequate power is available. If there is any question concerning the power supply, contact the local power company.

Inspecting Equipment: All units are securely packed at the time of shipment and, upon arrival, should be carefully inspected for damage. Claims for damage (apparent or concealed) should be filed immediately with the carrier.

INSTALLATION

1. SELECT THE BEST LOCATION FOR THE AIR CONDITIONING UNIT

IMPORTANT: DO NOT PLACE UNIT UNDER THE HOME.

- Select a solid, level position, preferably on a concrete slab, slightly above the grade level, and parallel to the home.
- The hot condenser air must be discharged up and away from the home, and if possible, in a direction with the prevailing wind.
- There should be no obstructions within twelve inches of the coil which could block the movement of the condenser air.
- Do not place the unit in a confined space.
- If practical, place the air conditioner where it and the ducts will be shaded from the afternoon sun when the heat load is greatest.
- Try to select a site for the unit that is as close as possible to the proposed return grille location.
- Keep in mind that the length of the supply and return ducts should be kept to a minimum with no sharp radiused bends.

2. UNPACK THE UNIT

It is recommended that the unit be unpacked at the installation site to minimize damage due to handling.

CAUTION:

Do not tip the unit on its side. Oil may enter the compressor cylinders and cause starting trouble. If unit has been set on its side, restore to upright position and do not run for several hours. Then run unit for a few seconds. Do this three or four times with five minutes between runs.

- a. Remove the bands from around the unit.
- b. Unfold the top and bottom cap flanges.
- c. Carefully remove the top cap and tube.

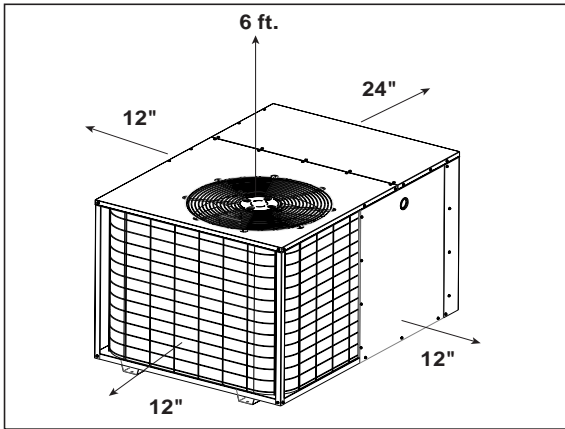

Figure 2. Minimum Unit Clearances

3. INSTALL THE RETURN AND SUPPLY AIR FITTINGS ON THE UNIT

The supply and return fittings are included with select models. If supplied, the duct fittings are shipped in the supply duct. They attach to the unit openings with a flange and bead arrangement, secured with two sheet metal screws. Note: For ease of access, install fitting before positioning unit in final location.

SUPPLY DUCT

Position the supply duct collar, if supplied, so the edge of the unit opening fits between the flange and the bead. Overlap the collar ends keeping the small screw holes underneath. Align the holes in the crimped area and install one screw.

Note: It may be necessary to loosen the four screws that hold the transition duct in order to install the supply fitting. Re-tighten when installation is complete.

Tap collar as necessary to ensure engagement with unit opening and install second screw. Tighten first screw. Rotate collar clockwise so joint is near three o'clock position.

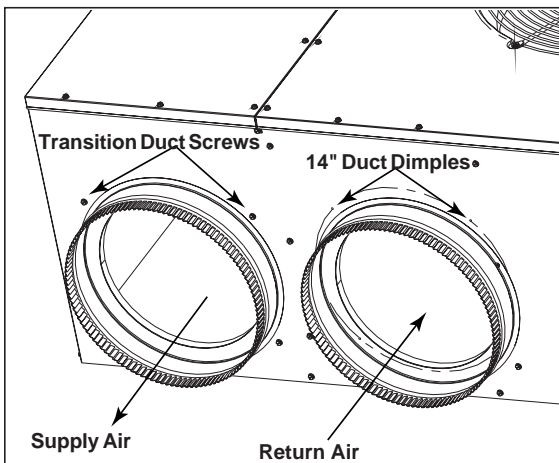

Figure 3. Return and Supply Air Fittings

RETURN DUCT

The 12" return duct is installed in the same manner as the supply duct. If the unit has a 14" return, follow these instructions.

10 SEER Model	Return Dia. (in)
2 Ton	12
2 1/2 Ton	12
3 Ton	12
3 1/2 Ton	12
4 Ton	14
5 Ton	14

12 SEER Model	Return Dia. (in)
2 Ton	12
2 1/2 Ton	12
3 Ton	12
3 1/2 Ton	14
4 Ton	14

Align the slots with the holes in the collar and install two screws. Position the collar over the opening and align the four notches in the collar with the four dimples in the panel. Using self-drilling screws (10-16x.5) attach the collar to the rear panel.

4. LOCATING AND INSTALLING THE RETURN AIR ASSEMBLY

To avoid complications, locate and install the return air assembly first. The return air box with grille and filter (Figure 4) should not be located in heavy traffic areas like hallways or center of rooms. A good spot is in a corner or under a table, if a minimum two inch clearance is available. If desired, the return opening can be located inside a closet with louvered doors that have an open area equal to or greater than the 12" x 20" grille furnished. The return air grille can be placed in the wall of a closet and the air ducted into the filter box through a boxed-in area at the closet floor level. Make sure the filter is readily accessible.

After determining the location of the return air opening, start the installation from under the home by cutting a small hole in the fiber underboard to determine how the floor joist

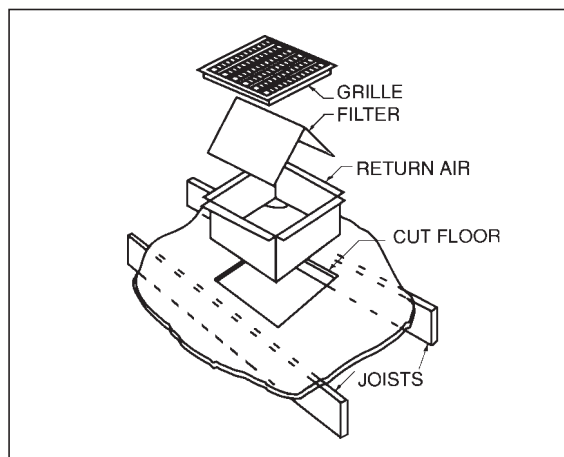

Figure 4. Return Air Box

location will affect cutting the opening needed for the box. Floor joists generally are located on 16" centers, leaving 14-3/8" between joists. After measuring the return air box (approximately 12-1/4" x 14-1/4"), cut the hole through the floor so that the box will fit between the floor joists. Care should be taken when cutting through carpeting to avoid snags. In most installations it will be necessary to cut a similar hole in the fiberboard directly under the hole in the floor. However, if the floor is more than ten inches deep, it will only be necessary to cut a hole for the collar on the return air box or for the insulated duct.

Set the box into the opening and fasten with screws or nails. Put the filter and return air grille in place.

5. LOCATING AND INSTALLING THE SUPPLY DAMPER(S)

CAUTION:

When a home is not equipped with a make-ready kit means must be provided to prevent simultaneous operation of the heating and cooling units. A heat/cool thermostat is available for this purpose.

When installing this air conditioning system in conjunction with a furnace, a damper must be installed in the furnace base assembly to prevent cold air being discharged around the heat exchanger. Damage to the heat exchanger and asphyxiation may occur if a damper is not installed.

Check with the furnace manufacturer for damper requirements. Failure to install the required furnace damper may invalidate code agency listing and limited warranty on the furnace.

When locating the supply damper(s), carefully check floor joists and frame members that could interfere with the installation of the damper or flexible duct. Ideally, the damper should be located in the bottom of the main duct, forward of center of the home, at least three feet from the

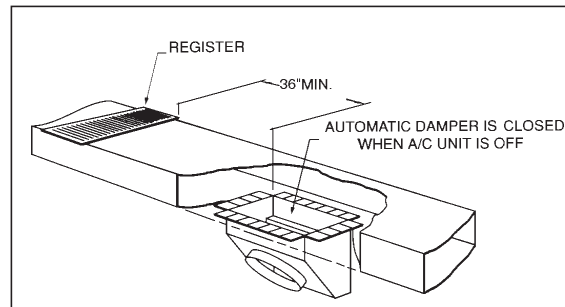

Figure 5. Supply Damper

nearest register. The round supply opening in the slanted side of the damper should face the side of the home where the air conditioner is located. To locate the center of the heat duct, first cut a small hole in the fiberboard below the duct at the desired location. After locating the duct center, cut a hole approximately 3/4" larger than the damper opening in the fiberboard. Cut a 9-1/8" x 13-1/8" hole in the duct and bend over all tabs flat on the inside of the heat duct. After inserting the damper into the duct, bend over all tabs flat on the inside of the heat duct. Seal the opening between the fiberboard and damper or flexible duct.

DUCTING SYSTEM

DUCT REQUIREMENTS

The supply duct system, including the number and type of registers, will have much more effect on the performance of an air conditioning system than any other factor. The duct must be sufficiently large to conduct an adequate amount of air to each register.

THE AIR CONDITIONING OUTPUT OF THE SYSTEM WILL NOT COOL THE HOME IF THE AIR IS LOST TO THE OUTSIDE THROUGH LEAKS IN THE DUCT SYSTEM. ALSO, DUCTS WHICH ARE COLLAPSED OR RESTRICTED BY FOREIGN OBJECTS WILL PREVENT ADEQUATE AIR FLOW.

Note: For highly resistive duct systems it may be necessary to add an additional return air duct and or supply to achieve maximum performance and prevent coil icing and refrigerant flood back.

CONNECTING THE RETURN AND SUPPLY AIR FLEXIBLE DUCTS

- a. The supply duct for all units is twelve inches in diameter. The return duct may be 12" or 14" diameter depending on unit size. (See Table on page 4).

TYPICAL APPLICATIONS

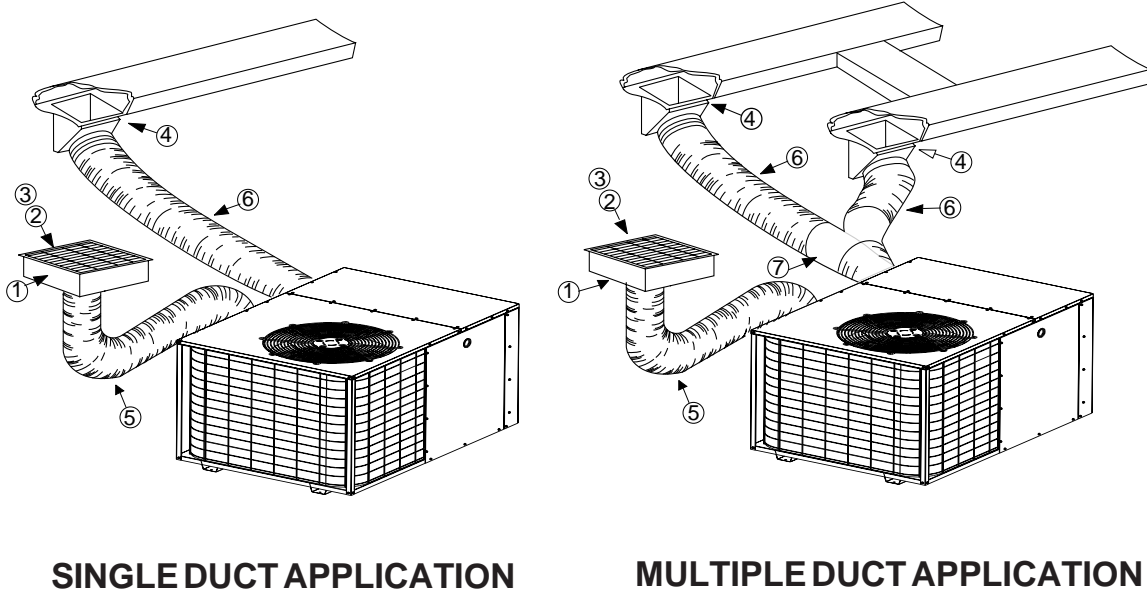

Ref. No.	Description
①	12" x 20" Return Air
②	16" x 20" Air Filter
③	12" x 20" Grille
④	Supply Damper
⑤	12" or 14" Diameter Flex Return Duct
⑥	12" Diameter Flex Supply Duct
⑦	12" x 12" x 12" "Y" Fitting

Figure 6. Typical Applications

- b. The flexible ducts can be connected to the corresponding fittings with the clamps provided with the ducts. Note: All connections should be leak tight or a loss in cooling capacity will result.
- c. The flexible ducts may be cut to the required length, see instructions packed with duct. Keep all ducts as short and straight as possible. Avoid sharp bends.
- d. Ducts may be spliced with sheet metal sleeves and clamps. (See Ducting Installation Accessories below.)
- e. Once the inner duct is connected to the proper fitting, the insulation and plastic sleeve should be pulled over the connection and clamped.
- f. For homes with multiple supply ducts or for special applications, a Y fitting is available to divide the supply air so it can be ducted to different areas of the home for more efficient cooling. Note: The Y fitting should be insulated for maximum performance.

Blower Speed — The blower speed is preset at the factory for operation at the same speed for heating and cooling. For optimum system performance and comfort, it may be necessary to change the factory set speed. To change the blower speed:

1. Disconnect all electrical power to the unit and remove the service panel.
2. See Figure 7 for wire color vs. motor speed guide.
3. Place the desired heating blower speed lead on the "NO" terminal of the blower relay. Use another wire tie (field supplied)

<u>Wire Color</u>	<u>Motor Speed</u>
Black	High
Red	Low

Figure 7. Motor Lead Connection

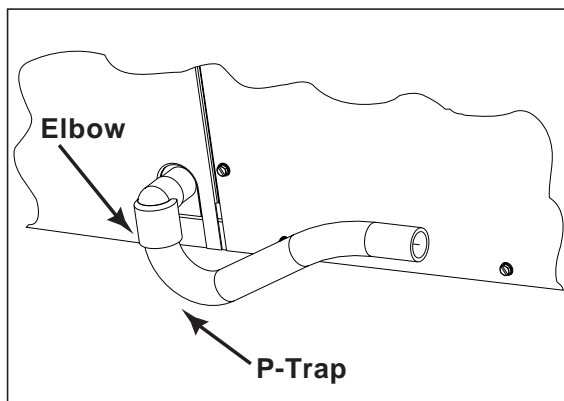

Figure 8. Drain Trap

to bundle the remaining motor lead up and out of the way.

! CAUTION:

To avoid personal injury or property damage, make certain that the motor leads cannot come into contact with any uninsulated metal components of the unit.

Check all factory wiring per the unit wiring diagram and inspect the factory wiring connections to be sure none loosened during shipping or installation.

CONDENSATE DRAIN

A 3/4" condensate fitting extends out of the side of the unit. The drain trap, shipped in the electrical compartment, must be installed to prevent water from collecting inside the unit. Thread the elbow provided with the unit into the drain connection until hand tight. Install the trap into the fitting and seal the joint. Make sure it is level. Route the condensate from the trap to a suitable drain. Any connecting tubing or hose must have the outlet below the trap level for proper drainage.

! WARNING:

Turn off electrical power before servicing controls. Severe electrical shock may result unless power is turned off. Unit must be installed in compliance with the National Electrical Code (NEC) and local codes.

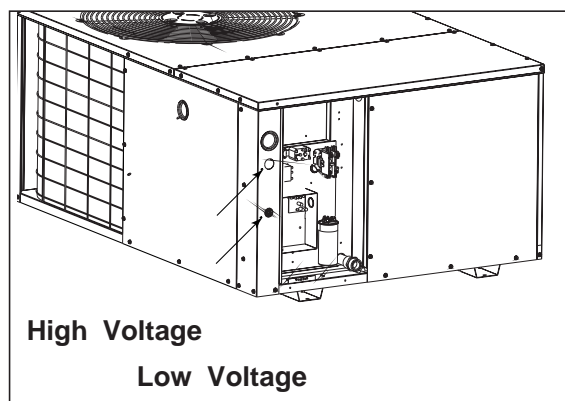

Figure 9. Power Entry

ELECTRICAL CONNECTIONS

1. ELECTRICAL SERVICE

High Voltage

- a. Install a branch circuit disconnect of adequate size per NEC. Locate the disconnect within sight of the unit.
- b. Extend leads through power wiring hole provided. Connect L1 and L2 directly to the contactor. (See Figure 9).
- c. Ground the air conditioning unit using the green grounding screw provided in the control panel.

Low Voltage

- a. Route 24v control wires through the sealing grommet near the power entrance.
- b. Connect the control wires to the leads in the low voltage area. (See Figure 10).

2. OVERCURRENT PROTECTION

In general, the best fuse or breaker for any air conditioner is the smallest size that will permit the equipment to run under normal use and service without nuisance trips. Such a device, sized properly, gives maximum equipment protection. The principal reason for specifying a time delay type is to prevent nuisance trips when the unit starts.

In the event that a fuse does blow or a breaker trips, always determine the reason. Do not arbitrarily put in a larger fuse or breaker and do not, in any case, exceed the maximum size listed on the data label of the unit.

3. LOCATING THE THERMOSTAT

Locate the thermostat away from drafts and slamming doors and place it where there is a free flow of air. Mount on an inside wall approximately five feet from the floor.

Do not locate near a lamp, kitchen range, direct sunlight, or in line with air flow from supply registers.

- a. **Connect Cooling Thermostat:** The cooling thermostat available for use with this system is equipped with a selector switch. To shut down the air conditioner, set the selector switch to the OFF position.

Connect the red and yellow wires from the unit to the R and Y terminals respectively on the thermostat subbase. Connect the green wire to the yellow wire at the unit. See the instruction sheet packed with the thermostat for detailed methods of mounting.

Note: The cooling-only thermostat must be connected to an interlock switch to prevent simultaneous operation of the furnace and the air conditioner. (See Figure 1, Page 2.)

- b. **Connect the Heat-Cool Thermostat:** The heat-cool thermostat is equipped with a system HEAT-COOL switch, which provides a positive means of preventing simultaneous operation of the heating and cooling units. The thermostat is also equipped with an ON-AUTO fan switch which allows the home owner to operate the indoor blower when air circulation is desired.

Connect the red, yellow, green and brown low voltage wires to the R or RC, Y, G and W terminals respectively on the thermostat base. The black wire is the 24 volt common required on some thermostats. See thermostat instruction sheet for more detailed information.

Refer to furnace installation instructions for required connections and proper heat anticipator setting when installing unit with an external furnace.

- c. **If two stage heating is desired, an optional outdoor thermostat may be installed:** Connect the thermostat to the orange low voltage wire and the W terminal on the indoor thermostat base (See Figure 10). See the thermostat instructions for details on setting the outdoor thermostat.

4. ELECTRIC HEAT PACKAGE (OPTIONAL)

The air conditioner is shipped without an auxiliary electric heat kit installed. If electric heat is desired, an accessory Heater Kit must be field installed. See Specifications Sheet for available kits and their applications.

- Select the correct size heat package for the installation.

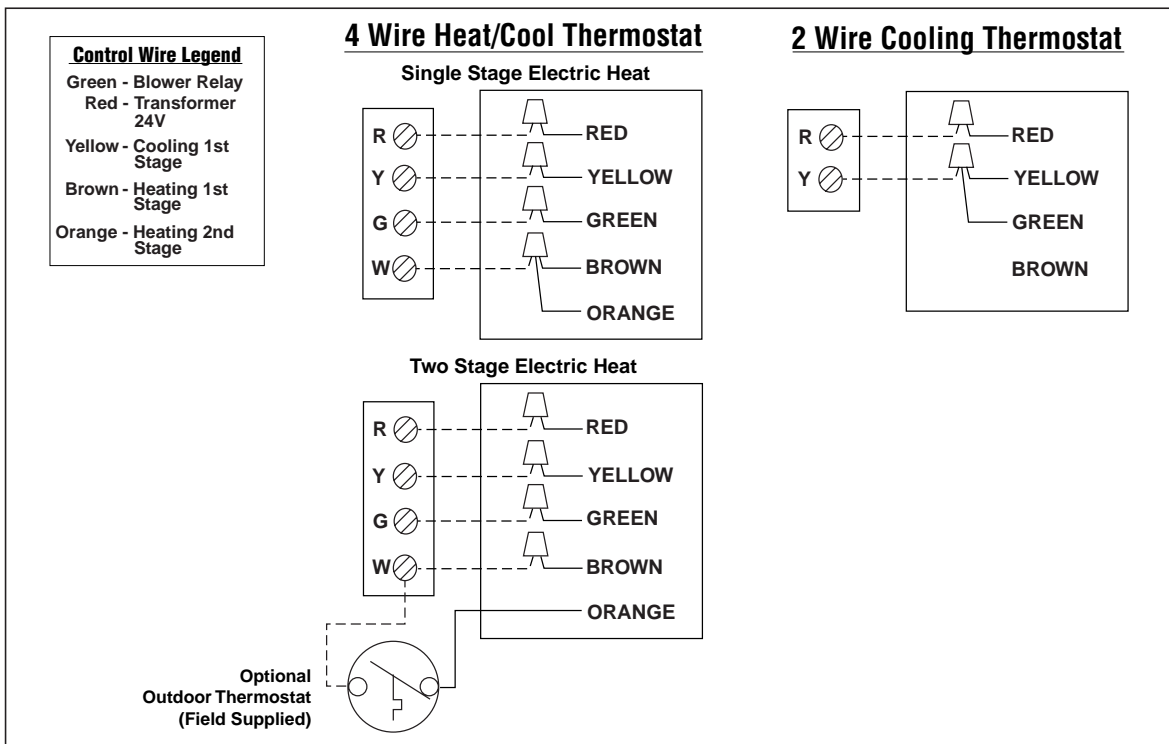

Figure 10. Low Voltage Connections

- Follow installation instructions provided with each heater kit.
- Installation is most easily accomplished before making duct or electrical connections.
- The blower must be set to high speed for electric heat operation.

- Is the overcurrent protection properly sized?
- Is the thermostat wired correctly? Is it installed in a proper location?

2. START-UP PROCEDURE

- a. Set the system switch to the OFF position.
- b. Dial thermostat setting as high as it will go.
- c. Turn on power supply at the disconnect switch.
- d. Set the system switch to ON or COOL. Set the temperature setting to below room temperature. Verify that the indoor blower, outdoor fan, and compressor are energized and the cooling function starts.
- e. Verify that the discharge air grilles are adjusted and the system is balanced.
- f. Verify that there are no air leaks in the duct work.
- g. Verify that the condensate drain is properly installed and that it functions correctly.
- h. Dial the thermostat higher than room temperature. The unit should stop.
- i. If using a combination heating-cooling thermostat, set to the HEAT position. Proceed to check for correct furnace operation.
- j. Verify that the furnace controls and burners or heating elements operate correctly.
- k. Instruct the owner on unit operation, filter servicing, and proper thermostat operation.

SYSTEM OPERATION

1. PRE-START CHECK LIST

The following check list should be observed prior to starting the unit.

- Is the unit level? It should be level or slightly slanted toward the drain for proper condensate drainage.
- Is there free air flow to and from the condenser? A one foot clearance around the coil, and six foot clearance above the fan?
- Is the wiring correct according to the wiring diagram and electrical codes?
- Are all the wiring connections tight? Check the condenser fan to make sure it turns freely.

10 SEER - Refrigerant Charging Tables

2 Ton

		OUTDOOR TEMPERATURE (°F)														
		70		75		80		85		90		95		100		105
Suct. Press.	Dis. Press.	Dis. Temp.	Dis. Temp.	Dis. Press.	Dis. Temp.	Dis. Temp.	Dis. Press.	Dis. Temp.	Dis. Temp.	Dis. Press.	Dis. Temp.	Dis. Temp.	Dis. Press.	Dis. Temp.	Dis. Press.	Dis. Temp.
70	180	136														
72	183	141	196	142												
74	185	146	198	147	212	149										
76	185	155	201	152	214	153	228	155								
78	189	158	201	159	216	158	230	159	243	160						
80			205	162	218	164	232	164	245	166	259	166				
82					221	167	234	168	247	169	261	170	274	172		
84							237	172	250	173	263	175	276	176	290	177
86							241	176	254	177	266	179	278	180	292	181
88									257	181	270	183	282	184	294	184
90											273	187	286	188	299	189
92													289	193	302	194
94															305	198
96																

2-1/2 Ton

		OUTDOOR TEMPERATURE (°F)														
		70		75		80		85		90		95		100		105
Suct. Press.	Dis. Press.	Dis. Temp.	Dis. Temp.	Dis. Press.	Dis. Temp.	Dis. Temp.	Dis. Press.	Dis. Temp.	Dis. Temp.	Dis. Press.	Dis. Temp.	Dis. Temp.	Dis. Press.	Dis. Temp.	Dis. Press.	Dis. Temp.
69	190	147														
71	193	152	207	152												
73	195	157	209	157	223	156										
75	196	165	211	162	225	161	239	161								
77	199	168	212	168	227	166	241	166	255	165						
79			216	171	229	171	243	170	257	170	271	169	287	173		
81					232	175	246	175	259	174	273	174	289	177	303	177
83							249	178	262	178	275	178	289	181	305	181
85							252	182	266	182	279	182	291	186	307	185
87									269	186	282	186	295	188	312	190
89											286	190	299	190	315	194
91													302	194	319	199
93																
95																

* Note: All pressures are listed in psig, and all temperatures in °F.

Shaded Boxes indicate flooded conditions

Rated Design Values. Suction Pressure will be lower than design value if indoor air flow, entering dry bulb, or entering wet bulb temperatures are lower than design.

Discharge temperatures greater than charted values indicate an undercharged system.

10 SEER - Refrigerant Charging Tables

3 Ton

Suct. Press.	OUTDOOR TEMPERATURE (°F)																
	70		75		80		85		90		95		100		105		
	Dis. Press.	Dis. Temp.	Dis. Press.	Dis. Temp.	Dis. Press.	Dis. Temp.	Dis. Press.	Dis. Temp.	Dis. Press.	Dis. Temp.	Dis. Press.	Dis. Temp.	Dis. Press.	Dis. Temp.	Dis. Press.	Dis. Temp.	
68	177	156															
70	180	161	198														
72	182	166	200	166	218	165											
74	184	173	202	171	220	170	238	170									
76	187	175	204	176	222	175	240	174	258	174							
78			208	179	224	179	242	179	260	178	278	178					
80					228	183	245	183	262	183	280	182	298	182			
82							248	187	265	187	282	186	300	186	318	186	
84							252	190	269	191	285	190	302	190	320	190	
86									272	194	289	195	306	194	322	194	
88											292	199	309	199	326	198	
90													313	203	329	203	
92															333	207	
94																	

3-1/2 Ton

Suct. Press.	OUTDOOR TEMPERATURE (°F)																
	70		75		80		85		90		95		100		105		
	Dis. Press.	Dis. Temp.	Dis. Press.	Dis. Temp.	Dis. Press.	Dis. Temp.	Dis. Press.	Dis. Temp.	Dis. Press.	Dis. Temp.	Dis. Press.	Dis. Temp.	Dis. Press.	Dis. Temp.	Dis. Press.	Dis. Temp.	
68	195	148															
70	197	153	213	155													
72	199	159	216	160	232	161											
74	200	167	218	165	234	166	250	168									
76	204	170	219	172	236	171	252	172	268	174							
78			222	175	238	176	254	177	270	178	286	180					
80					241	180	256	182	272	183	288	184	304	186			
82							260	185	275	187	290	188	306	190	323	191	
84							263	189	279	191	294	192	308	194	325	195	
86									282	195	297	197	313	198	327	199	
88											301	201	316	202	331	204	
90													319	207	335	208	
92															338	213	
94																	

* Note: All pressures are listed in psig, and all temperatures in °F.

- Shaded Boxes indicate flooded conditions

- Rated Design Values. Suction Pressure will be lower than design value if indoor air flow, entering dry bulb, or entering wet bulb temperatures are lower than design.

- Discharge temperatures greater than charted values indicate an undercharged system.

10 SEER - Refrigerant Charging Tables

4 Ton

		OUTDOOR TEMPERATURE (°F)															
		70		75		80		85		90		95		100		105	
Suct. Press.	Dis. Press.	Dis. Temp.	Dis. Temp.	Dis. Press.	Dis. Temp.	Dis. Press.	Dis. Temp.	Dis. Press.	Dis. Temp.	Dis. Press.	Dis. Temp.	Dis. Press.	Dis. Temp.	Dis. Press.	Dis. Temp.	Dis. Press.	Dis. Temp.
68	195	148															
70	197	153	213	155													
72	199	159	216	160	232	161											
74	200	167	218	165	234	166	168										
76	204	170	219	172	236	171	172	268	174								
78			222	175	238	176	177	270	178	286	180						
80					241	180	182	272	183	288	184	304	186				
82							185	275	187	290	188	306	190	323	191		
84							189	279	191	294	192	308	194	325	195		
86								282	195	297	197	313	198	327	199		
88									301	301	201	316	202	331	204		
90												319	207	335	208		
92														338	213		
94																	

5 Ton

		OUTDOOR TEMPERATURE (°F)															
		70		75		80		85		90		95		100		105	
Suct. Press.	Dis. Press.	Dis. Temp.	Dis. Temp.	Dis. Press.	Dis. Temp.	Dis. Press.	Dis. Temp.	Dis. Press.	Dis. Temp.	Dis. Press.	Dis. Temp.	Dis. Press.	Dis. Temp.	Dis. Press.	Dis. Temp.	Dis. Press.	Dis. Temp.
63	207	155															
65	209	160	224	161													
67	211	165	226	166	241	166											
69	211	175	228	171	243	171	172	259	172								
71	215	177	229	178	246	176	176	261	177	276	177						
73			233	181	247	181	181	263	181	278	181	293	182				
75					251	185	185	265	185	280	185	295	186	310	186		
77							189	268	189	283	190	297	190	312	190	327	191
79							193	272	193	286	193	300	194	314	194	329	195
81									197	290	197	304	198	318	199	331	198
83										307	202	322	203	336	204		
85												325	207	339	208		
87														343	212		
89																	

* Note: All pressures are listed in psig, and all temperatures in °F.

Shaded Boxes indicate flooded conditions

- Rated Design Values. Suction Pressure will be lower than design value if indoor air flow, entering dry bulb, or entering wet bulb temperatures are lower than design.

- Discharge temperatures greater than charted values indicate an undercharged system.

12 SEER - Refrigerant Charging Tables

2 Ton

Suct. Press	OUTDOOR TEMPERATURE (°F)																
	70		75		80		85		90		95		100		105		
	Dis. Press	Dis. Temp.	Dis. Press	Dis. Temp.	Dis. Press	Dis. Temp.	Dis. Press	Dis. Temp.	Dis. Press	Dis. Temp.	Dis. Press	Dis. Temp.	Dis. Press	Dis. Temp.	Dis. Press	Dis. Temp.	
72	170	123															
74	172	129	186	132													
76	174	134	189	137	203	140											
78	175	142	191	142	205	145	219	149									
80	179	144	192	148	207	150	221	153	236	157							
82			196	151	209	155	224	158	238	161	252	164					
84					213	158	226	162	240	165	254	169	268	172			
86							229	166	243	169	256	173	270	176	285	180	
88							233	169	246	173	260	177	272	180	287	183	
90									250	177	263	181	276	184	289	187	
92											266	185	280	189	293	192	
94													283	193	297	197	
96															300	201	
98																	

2-1/2 Ton

Suct. Press	OUTDOOR TEMPERATURE (°F)																
	70		75		80		85		90		95		100		105		
	Dis. Press	Dis. Temp.	Dis. Press	Dis. Temp.	Dis. Press	Dis. Temp.	Dis. Press	Dis. Temp.	Dis. Press	Dis. Temp.	Dis. Press	Dis. Temp.	Dis. Press	Dis. Temp.	Dis. Press	Dis. Temp.	
73	172	125															
75	174	131	189	132													
77	176	136	191	137	206	139											
79	176	146	193	142	208	144	223	145									
81	180	148	194	150	210	148	225	150	240	151							
83			197	153	212	154	227	154	242	155	257	157					
85					215	157	229	159	244	160	259	161	274	162			
87							233	162	247	164	261	165	276	166	291	167	
89							236	166	251	168	265	169	278	170	293	171	
91									254	172	268	173	282	175	295	175	
93											272	177	286	179	300	180	
95													289	183	304	185	
97															307	189	
99																	

* Note: All pressures are listed in psig, and all temperatures in °F.

- Shaded Boxes indicate flooded conditions

- Rated Design Values. Suction Pressure will be lower than design value if indoor air flow, entering dry bulb, or entering wet bulb temperatures are lower than design.

- Discharge temperatures greater than charted values indicate an undercharged system.

12 SEER - Refrigerant Charging Tables

3 Ton

		OUTDOOR TEMPERATURE (°F)															
		70		75		80		85		90		95		100		105	
Suct. Press.	Dis. Press.	Dis. Temp.	Dis. Press.	Dis. Temp.	Dis. Press.	Dis. Temp.	Dis. Press.	Dis. Temp.	Dis. Press.	Dis. Temp.	Dis. Press.	Dis. Temp.	Dis. Press.	Dis. Temp.	Dis. Press.	Dis. Temp.	
70	172	130															
72	174	135	189	134													
74	176	140	191	139	206	139											
76	175	152	193	144	208	143	223	143									
78	179	154	193	153	210	148	225	147	240	146							
80			196	156	211	155	227	152	242	151	256	150					
82					214	158	228	157	244	155	258	154	273	153			
84							232	161	246	159	261	158	275	157	290	156	
86							235	164	250	163	264	162	277	161	292	160	
88									253	167	267	166	282	166	294	164	
90											271	171	285	170	299	169	
92													288	174	303	173	
94															306	178	
96																	

3-1/2 Ton

		OUTDOOR TEMPERATURE (°F)															
		70		75		80		85		90		95		100		105	
Suct. Press.	Dis. Press.	Dis. Temp.	Dis. Press.	Dis. Temp.	Dis. Press.	Dis. Temp.	Dis. Press.	Dis. Temp.	Dis. Press.	Dis. Temp.	Dis. Press.	Dis. Temp.	Dis. Press.	Dis. Temp.	Dis. Press.	Dis. Temp.	
69	169	137															
71	171	143	186	142													
73	174	148	188	147	204	146											
75	175	155	191	152	206	151	221	150									
77	179	157	193	157	208	156	223	155	238	154							
79			196	160	210	161	225	160	240	159	255	158					
81					214	164	228	164	242	163	257	162	272	162			
83							231	167	245	167	259	167	274	166	289	166	
85							235	171	249	171	263	171	276	170	291	169	
87									252	175	266	175	280	174	293	173	
89											269	179	283	179	297	178	
91													287	183	301	182	
93															304	187	
95																	

* Note: All pressures are listed in psig, and all temperatures in °F.

- Shaded Boxes indicate flooded conditions

- Rated Design Values. Suction Pressure will be lower than design value if indoor air flow, entering dry bulb, or entering wet bulb temperatures are lower than design.

- Discharge temperatures greater than charted values indicate an undercharged system.

12 SEER - Refrigerant Charging Tables

4 Ton

	OUTDOOR TEMPERATURE (°F)															
	70		75		80		85		90		95		100		105	
Suct. Press.	Dis. Press.	Dis. Temp.	Dis. Press.	Dis. Temp.	Dis. Press.	Dis. Temp.	Dis. Press.	Dis. Temp.	Dis. Press.	Dis. Temp.	Dis. Press.	Dis. Temp.	Dis. Press.	Dis. Temp.	Dis. Press.	Dis. Temp.
68	173	135														
70	175	140	191	141												
72	178	146	193	146	208	146										
74	178	155	195	151	211	151	226	151								
76	181	158	196	158	213	156	228	156	243	156						
78			199	161	214	161	230	160	246	161	261	161				
80					218	165	232	165	248	165	263	165	278	165		
82							236	169	250	169	265	169	280	169	296	169
84							239	172	254	173	268	173	282	173	298	173
86									257	177	272	177	286	178	300	177
88											275	181	290	182	305	182
90													293	186	308	187
92															311	191
94																

*Note: All pressures are listed in psig. and all temperatures in °F.

Shaded Boxes indicate flooded conditions

- Rated Design Values. Suction Pressure will be lower than design value if indoor air flow, entering dry bulb, or entering wet bulb temperatures are lower than design.

- Discharge temperatures greater than charted values indicate an undercharged system.

INSTALLER

**PLEASE LEAVE THESE
INSTALLATION INSTRUCTIONS
WITH THE HOMEOWNER.**



708108A

708108A (Replaces 7081080)

Specifications and illustrations subject to change
without notice and without incurring obligations.
Printed in U.S.A. (08/02)