

# NHP SAFETY REFERENCE GUIDE

GuardLogix



## SAFETY FUNCTION DOCUMENTS

Light Curtain



Authorised  
Distributor

# Safety Function Documents: GuardLogix

## Light Curtain GuardLogix® Controller

Safety Rating: PL<sub>e</sub>, Cat. 4 to EN ISO 13849.1 2008



### Table of Contents:

<b>Introduction</b>	<b>6-22</b>
<b>Important User Information</b>	<b>6-22</b>
<b>Safety Function Realization</b>	<b>6-23</b>
<b>General Safety Information</b>	<b>6-23</b>
<b>Setup and Wiring</b>	<b>6-25</b>
<b>Configuration</b>	<b>6-27</b>
<b>Programming</b>	<b>6-31</b>
<b>Falling Edge Reset</b>	<b>6-32</b>
<b>Calculation of the Performance Level</b>	<b>6-33</b>
<b>Verification and Validation Plan</b>	<b>6-35</b>
<b>Additional Resources</b>	<b>6-38</b>

# Safety Function Documents: GuardLogix

## Light Curtain GuardLogix® Controller

Safety Rating: PLe, Cat. 4 to EN ISO 13849.1 2008

### Introduction

This Safety Function application note explains how to wire, configure, and program a Compact GuardLogix® controller and POINT Guard I/O™ module to monitor a 440L GuardShield light curtain. If a demand is placed on the light curtain or a fault is detected in the monitoring circuit, the GuardLogix controller de-energizes the final control device, in this case, a redundant pair of 100S contactors.

This example uses a Compact GuardLogix controller, but is applicable to any GuardLogix controller. This example uses a 440L GuardShield light curtain, but is applicable to light curtains that pulse tests the OSSD1 and OSSD2 outputs. The SISTEMA calculations shown later in this document would have to be re-calculated using the actual products.

### Important User Information

Solid state equipment has operational characteristics differing from those of electromechanical equipment. Safety Guidelines for the Application, Installation and Maintenance of Solid State Controls (publication SGI-1.1 available from your local Rockwell Automation® sales office or online at <http://www.rockwellautomation.com/literature>) describes some important differences between solid state equipment and hard-wired electromechanical devices. Because of this difference, and also because of the wide variety of uses for solid state equipment, all persons responsible for applying this equipment must satisfy themselves that each intended application of this equipment is acceptable.

In no event will Rockwell Automation, Inc. be responsible or liable for indirect or consequential damages resulting from the use or application of this equipment.

The examples and diagrams in this manual are included solely for illustrative purposes. Because of the many variables and requirements associated with any particular installation, Rockwell Automation, Inc. cannot assume responsibility or liability for actual use based on the examples and diagrams.

No patent liability is assumed by Rockwell Automation, Inc. with respect to use of information, circuits, equipment, or software described in this manual.

Reproduction of the contents of this manual, in whole or in part, without written permission of Rockwell Automation, Inc., is prohibited.

# Safety Function Documents: GuardLogix

## Light Curtain GuardLogix® Controller

Safety Rating: PLe, Cat. 4 to EN ISO 13849.1 2008

### Safety Function Realization: Risk Assessment

The required performance level is the result of a risk assessment and refers to the amount of the risk reduction to be carried out by the safety-related parts of the control system. Part of the risk reduction process is to determine the safety functions of the machine. For the purposes of this document the assumed required performance level is Category 4, PLe.

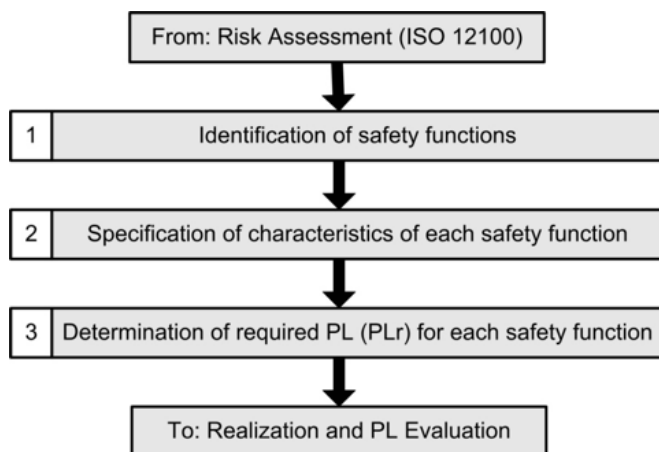

### Emergency Stop Safety Function

Emergency stop by actuation of a light curtain; Point of Operation Control. There is no muting function in this example.

### Safety Function Requirements

Interrupting the light curtain will stop and prevent hazardous motion by removal of power to the motor. Upon resetting the light curtain, hazardous motion and power to the motor will not resume until a secondary action (start button depressed) occurs. Faults at the light curtain, wiring terminals or safety controller will be detected before the next safety demand. The safe distance location of the light curtain must be established such that the hazardous motion must be stopped before the user can reach the hazard. The safety function in this example is capable of connecting and interrupting power to motors rated up to 9A, 600VAC.

The safety function will meet the requirements for Category 4, Performance Level “e” (Cat 4, PLe), per ISO 13849-1, and SIL3 per IEC 62061, and control reliable operation per ANSI B11.19.

Throughout this manual, when necessary, we use notes to make you aware of safety considerations.

	<b>WARNING:</b> Identifies information about practices or circumstances that can cause an explosion in a hazardous environment, which may lead to personal injury or death, property damage, or economic loss.
<b>IMPORTANT</b>	Identifies information that is critical for successful application and understanding of the product.
	<b>ATTENTION:</b> Identifies information about practices or circumstances that can lead to personal injury or death, property damage, or economic loss. Attentions help you identify a hazard, avoid a hazard, and recognize the consequence.
	<b>SHOCK HAZARD:</b> Labels may be on or inside the equipment, for example, a drive or motor, to alert people that dangerous voltage may be present.
	<b>BURN HAZARD:</b> Labels may be on or inside the equipment, for example, a drive or motor, to alert people that surfaces may reach dangerous temperatures.

### General Safety Information

Contact Rockwell Automation to find out more about our safety risk assessment services.

<b>IMPORTANT</b>	This application example is for advanced users and assumes that you are trained and experienced in safety system requirements.
	<b>ATTENTION:</b> A risk assessment should be performed to make sure all task and hazard combinations have been identified and addressed. The risk assessment may require additional circuitry to reduce the risk to a tolerable level. Safety circuits must take into consideration safety distance calculations which are not part of the scope of this document.

# Safety Function Documents: GuardLogix

## Light Curtain GuardLogix® Controller

Safety Rating: PLe, Cat. 4 to EN ISO 13849.1 2008

### Functional Safety Description

Hazardous motion is interrupted or prevented by interrupting the light curtain. The light curtain (LC1) is wired to a pair of safety inputs on a Safety Input module (SI1). The safety contactors (K1 & K2) are connected to a pair of safety outputs on a Safety Output module (SO1). The I/O module is connected via CIP Safety over an EtherNet/IP network to the Safety Controller (SC1). The safety code in SC1 monitors the status of the Light Curtain using the pre-certified safety instruction 'Dual Channel Input Stop' (DCS).

When all safety input interlocks are satisfied, no faults are detected, and the reset push button is pressed, a second certified function block called Configurable Redundant Output (CROUT) controls and monitors feedback for a pair of 100S redundant contactors. In summary, when the Light Curtain is blocked, the contactors drop out. When the Light Curtain is unblocked, and the reset button is pressed, the contactors are energized.

### Bill of Material

This application example uses these components.

Cat. No.	Description	Quantity
440L-P4JL0640YD	GuardShield™ Safety Light Curtain, Res 14mm, Pt Ht 640mm, 64 Beams, Integrated Laser Alignment	1
889D-F4AC-2	DC Micro (M12), Female, Straight, 4-Pin, PVC Cable, Yellow, Unshielded, 22AWG, 2 meter	1
889D-F8AB-2	DC Micro (M12), Female, Straight, 8-Pin, PVC Cable, Yellow, Unshielded, 24AWG, 2 meter	1
800FM-G611MX10	800F Reset Push Button - Metal, Guarded, Blue, R, Metal Latch Mount, 1 N.O. Contact(S), Standard	1
100S-C09ZJ23C	Bulletin 100S-C - Safety Contactors	2
1768-ENBT	CompactLogix™ EtherNet/IP Bridge Module	1
1768-L43S	Compact GuardLogix® Processor, 2.0 MB standard memory, 0.5 MB safety memory	1
1768-PA3	Power Supply, 120/240 VAC Input, 3.5 A @ 24V DC	1
1769-ECR	Right End Cap/Terminator	1
1734-AENT	24V DC Ethernet Adapter	1
1734-TB	Module Base with Removable IEC Screw Terminals	4
1734-IB8S	POINT Guard Safety Input Module	1
1734-OB8S	POINT Guard Safety Output Module	1
1783-US05T	Stratix 2000™ Unmanaged Ethernet Switch	1

# Safety Function Documents: GuardLogix

## Light Curtain GuardLogix® Controller

Safety Rating: PLe, Cat. 4 to EN ISO 13849.1 2008

### Setup and Wiring

For detailed information on installing and wiring, refer to the product manuals listed in the Additional Resources.

### System Overview

The 1734-IB8S input module monitors OSSD1 and OSSD2 from the 440L light curtain. If the Light Curtain is blocked, OSSD1 and OSSD2 go LO, and the controller will react by dropping out the safety contactors.

The 440L has onboard diagnostics to dynamically test the signal wiring for shorts to 24Vdc and channel to channel shorts. If a fault occurs, either or both OSSD1 and OSSD2 will be set LO, and the controller will react by dropping out the safety contactors.

Shorts to 0V DC (and wire off) will be seen as an open circuit by the 1734-IB8S input module and the controller will react by dropping out the safety contactors. If the inputs remain discrepant for longer than the discrepancy time, then the function block (DCS) in the controller will declare a fault. Only after the fault is cleared and the light curtain is cycled (blocked, then unblocked) will the function block reset.

The final control device in this case is a pair of 100S safety contactors, K1 and K2. The contactors are controlled by a 1734-OBS safety output module. The contactors are wired in a redundant series configuration. A feedback circuit is wired through the N/O contacts and back to an input on the 1734-IB8S module to monitor the contactors for proper operation. The contactors cannot restart if the feedback circuit is not in the correct state.

The system has individual reset buttons for resetting faults and safety outputs.

Note that the reset buttons and the contactor feedback circuit are all wired to the 1734-IB8S module in this example. This is not required for functional safety. These three (3) inputs could be wired to a standard input module.

### Safe Distance Calculation

The user will need to perform a calculation using this formula to determine the distance between the light curtain and the hazard. The user will need to use values based on their application; rather than the example calculation shown here:

$$S = (K * T) + C$$

K = 63 inches per second (constant from B11.19-1990)

T = stopping time

C = Depth Penetration Factor = 1 inch (for 14mm resolution; from documentation)

Stopping time (T) for this example is a summation of the following:

- a) Light Curtain delay = 25ms (from documentation)
- b) 1734-IB8S module delay = 16ms (from documentation)
- c) Input Module Connection delay
- d) Safety Controller delay
  - Safety Task Watchdog
  - Safety Task Period
- e) Output Module Connection delay
- f) 1734-OB8S delay = 6ms (from documentation)
- g) Contactor response time = 15ms (from documentation)
- h) Actual Machine stop time = assume 900ms for this example

C - The Input Module connection delay defaults to 4 x RPI

If we assume a RPI of 10ms; the maximum delay = 40ms

E - The Output Module connection delay defaults to 3 x RPI

If we assume a RPI of 10ms; the maximum delay = 30ms

The worst case reaction time may be calculated assuming there is only a single fault in the control system. This means that only the higher of the two connection delay values shown above needs to be included in the Time calculation. For this example, 40 ms is used; and the 30 is excluded. If you wish to account for multiple faults occurring at the same time; use both values in the calculation.

D - The safety controller delay is a combination of the safety task period plus the safety task watchdog. The watchdog accounts for the possibility that the safety code runs right up to, but does not trip the watchdog. The safety task period accounts for the possibility that the asynchronous scan just ended when the input changed state. For this example, let's assume:

Safety Task Period = 10ms

Safety Task Watchdog = 5ms

So to calculate T; add the following:

Light Curtain delay = 25ms

1734-IB8S module delay = 16ms

Higher of Input/Output Module Connection delay = 40ms

Safety Controller delay = 10+5 = 15ms

1734-OB8S delay = 6ms

Contactor response time = 15ms

Measured actual machine stop time = 900ms

This makes the total stop time (T) = 1017ms

$$S = (K * T) + C = (63 * 1.017) + 1 = 65.071 \text{ inches}$$

Given this example, the light curtain must be placed 65 inches from the hazard.

# Safety Function Documents: GuardLogix

## Light Curtain GuardLogix® Controller

Safety Rating: PLe, Cat. 4 to EN ISO 13849.1 2008

### Safe Distance calculation to 13855

$$S = (K \times T) + C$$

S: minimum distance, in millimeters (mm)

K: is a parameter, in millimeters per second (mm/s), derived from data on approach speeds of the body or parts of the body

T: is the overall stopping performance in seconds

C: is the intrusion distance in mm

In this Application Note the values are:

K = 1600mm per second

T = Sum of

Light Curtain delay = 25ms

1734-IB8S module delay = 16ms

Higher of Input/Output Module Connection delay = 40ms

Safety Controller delay = 10+5 = 15ms

1734-OB8S delay = 6ms

Contactor response time = 15ms

Measured actual machine stop time = 900ms

This makes the total stop time (T) = 1017ms

C = 8(d-14) but not less than 0 where d is the resolution of the light curtain

$$S = 1600 \times 1.017 + 8(14 - 14)$$

The light curtain must not be mounted closer than 1628 mm (approx. 64 in) from the hazardous motion being guarded against.

### Electrical Schematic

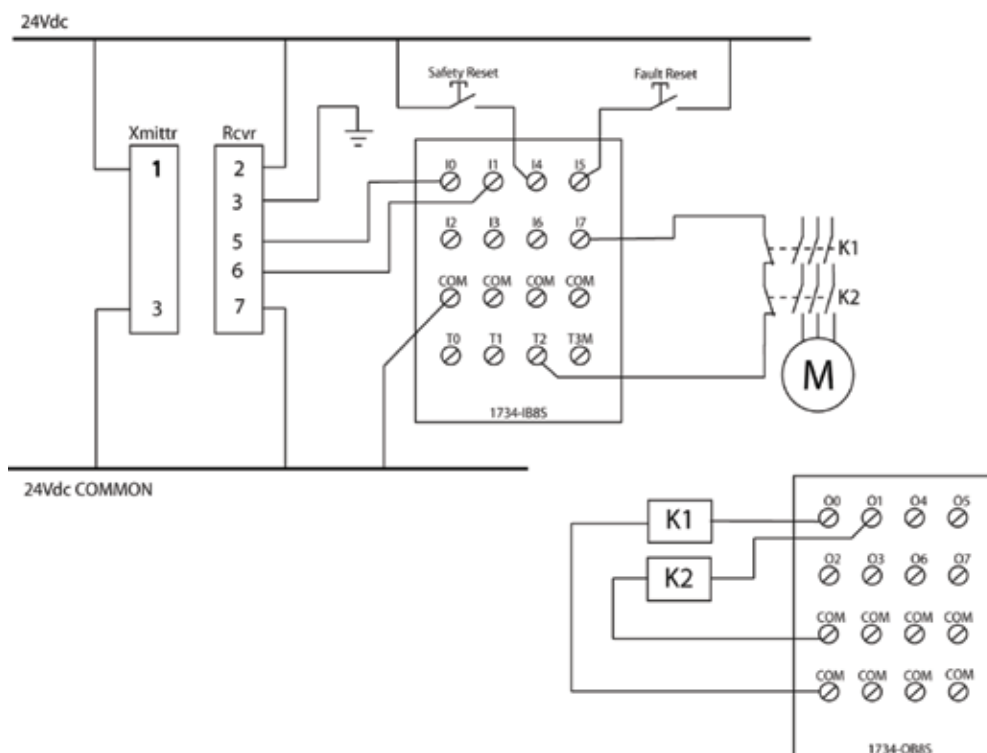

# Safety Function Documents: GuardLogix

## Light Curtain GuardLogix® Controller

Safety Rating: PLe, Cat. 4 to EN ISO 13849.1 2008

### Configuration

There are dip switches in the 400L light curtain. These can remain in the factory default position.

#### Receiver - Factory Settings

Switch	Switch Function	Default Setting	Description
1	Mode Activation - Combination activates one of the following modes: Guard Only, Start Interlock, Restart Interlock	ON	Guard Only
2		ON	
3	MPCE: Monitoring Disable	ON	Disabled
4	Fixed Blanking Activate	OFF	Disabled
5	Floating Blanking Activate - Single Beam	OFF	Switches 5&6 cannot be activated "On" at the same time
6	Floating Blanking Activate - Two Beams	OFF	
7	Set Beam Coding	OFF	Disabled
8	Not Used	OFF	

#### Transmitter - Factory Settings

Switch	Switch Function	Default Setting	Description
1	Set Beam Coding	OFF	Disabled
2	Machine Test Signal	OFF	OFF: Signal High Active—No connection or connect normally open ON: Signal Low Active—Connect N/C

The Compact GuardLogix controller is configured by using RSLogix™ 5000 software, version 17 or later. You must create a new project and add the I/O modules. Then, configure the I/O modules for the correct input and output types. A detailed description of each step is beyond the scope of this document. Knowledge of the RSLogix programming environment is assumed.

### Configure the Controller and Add I/O Modules

Follow these steps.

1. In RSLogix 5000 software, create a new project.
2. In the Controller Organizer, add the 1768-ENBT module to the 1768 Bus.

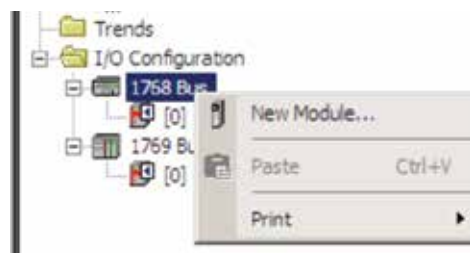



# Safety Function Documents: GuardLogix

## Light Curtain GuardLogix® Controller

Safety Rating: PLe, Cat. 4 to EN ISO 13849.1 2008

### Configure the Controller and Add I/O Modules cont.

Follow these steps.

3. Select the 1768-ENBT module and click OK.

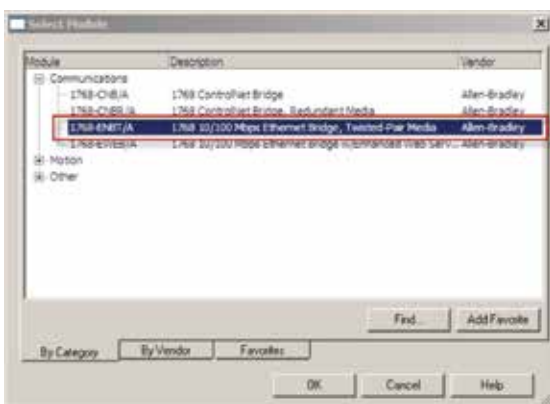

4. Name the module, type its IP address, and click OK. We used 192.168.1.8 for this application example. Yours may be different.

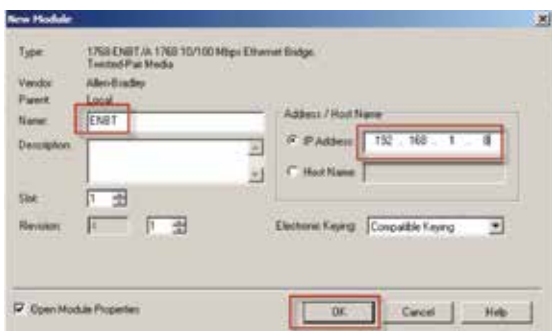

5. Add the 1734-AENT adapter by right-clicking the 1768-ENBT module in the Controller Organizer and choosing New Module.

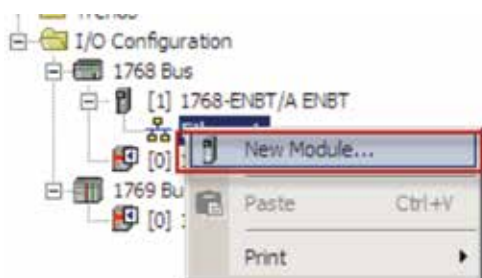

6. Select the 1734-AENT adapter and click OK.

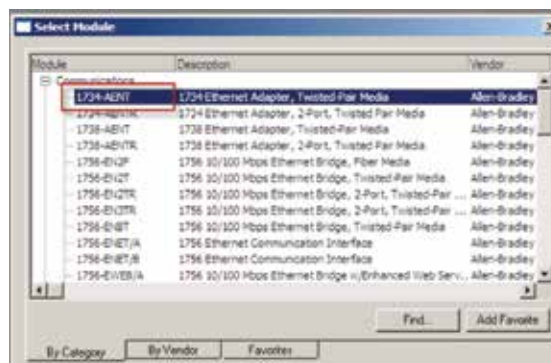

7. Name the module, type its IP address, and click OK. We used 192.168.1.11 for this application example. Yours may be different.

8. Click Change.

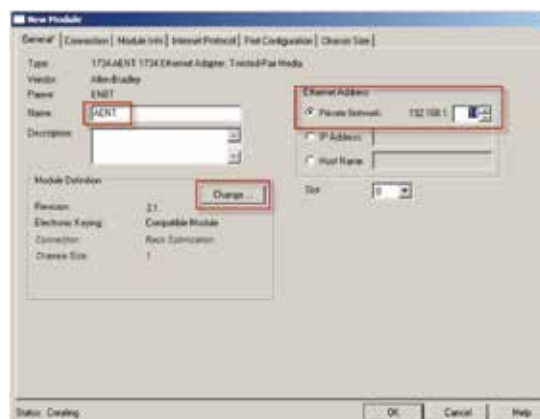

# Safety Function Documents: GuardLogix

## Light Curtain GuardLogix® Controller

Safety Rating: PLe, Cat. 4 to EN ISO 13849.1 2008

### Configure the Controller and Add I/O Modules cont.

- Set the Chassis Size as 3 for the 1734-AENT adapter and click OK. Chassis size is the number of modules that will be inserted in the chassis. The 1734-AENT adapter is considered to be in slot 0, so for one input and one output module, the chassis size is 3.

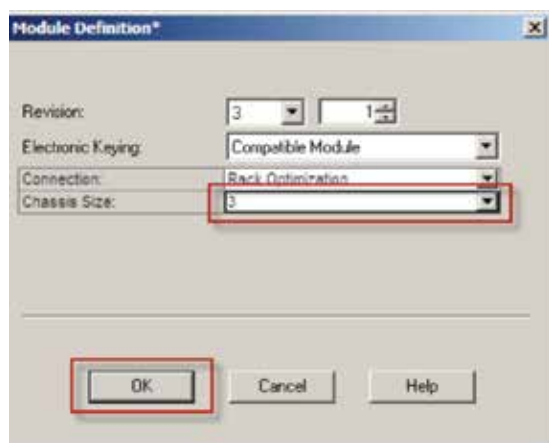

- In the Controller Organizer, right-click the 1734-AENT adapter and choose New Module.

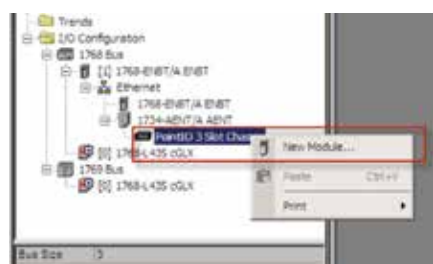

- Expand Safety, select the 1734-IB8S module, and click OK.

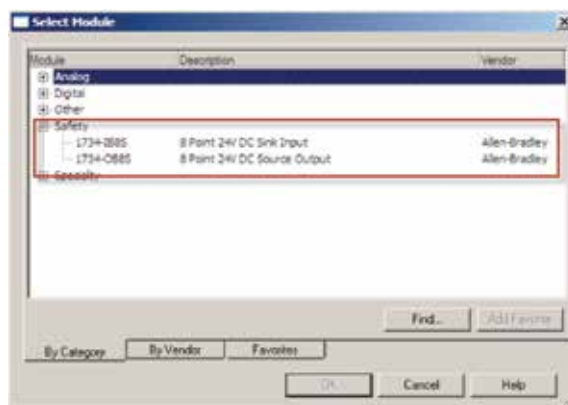

- In the New Module dialog box, name the device 'IB8S' and click Change.

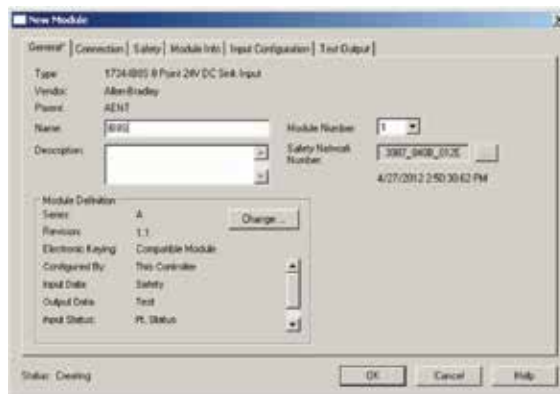

# Safety Function Documents: GuardLogix

## Light Curtain GuardLogix® Controller

Safety Rating: PLe, Cat. 4 to EN ISO 13849.1 2008

### Configure the Controller and Add I/O Modules cont.

- When the Module Definition dialog box opens, change the Output Data to 'None' and verify the Input Status is 'Combined Status-Power', and click OK. Setting the output data to None means that you cannot use the Test Outputs as standard outputs, and we are not doing that in this example. Note this saves one (1) controller connection because we are only using the input connection.

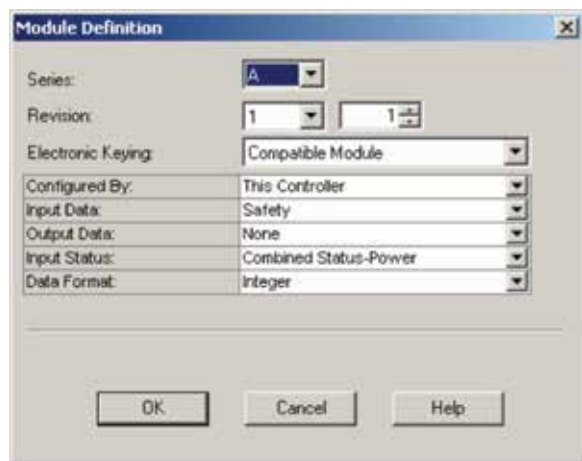

- Close the Module Properties dialog box by clicking OK.
- Repeat steps 10-14 to add the 1734-OB8S safety output module. Name the module OB8S. Note this module will be in slot 2, and select 'Combined Status-Readback-Power' for Input Status definition.

### Configure the I/O Modules

Follow these steps to configure the POINT Guard I/O modules.

- In the Controller Organizer, right-click the 1734-IB8S module and choose Properties.
- Click Test Output and configure the module as shown.

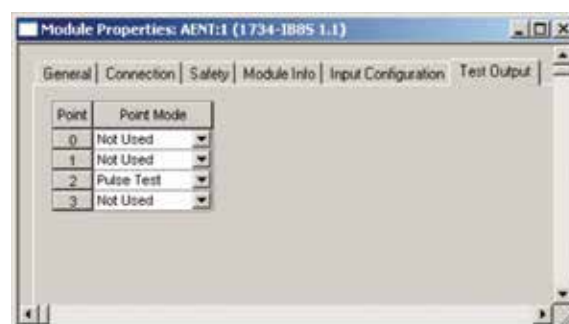

- Click Input Configuration and configure the module as shown. Inputs 0/1 are the Light Curtain. Inputs 4/5 are the reset buttons. Input 7 is contactor monitoring circuit. Recall that input 7 is being sourced from Test Output 2. Note that there really is no difference when an input channel is configured for safety or standard. It is used more for documentation.

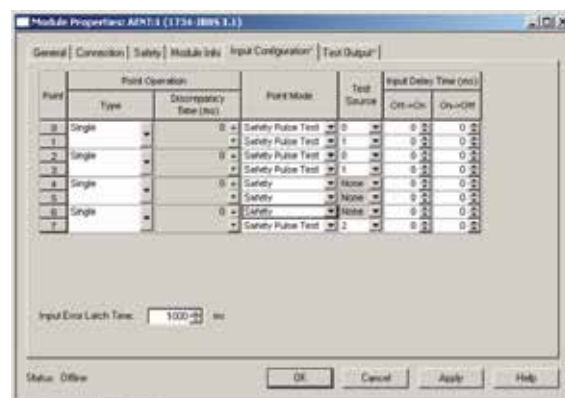

- Click OK.
- In the Controller Organizer, right-click the 1734-OB8S module and choose Properties.

# Safety Function Documents: GuardLogix

## Light Curtain GuardLogix® Controller

Safety Rating: PLe, Cat. 4 to EN ISO 13849.1 2008

### Configure the I/O Modules cont.

- Click Output Configuration and configure the module as shown. The electromechanical coil on the contactor can be pulse tested without reacting to the brief LO pulse.

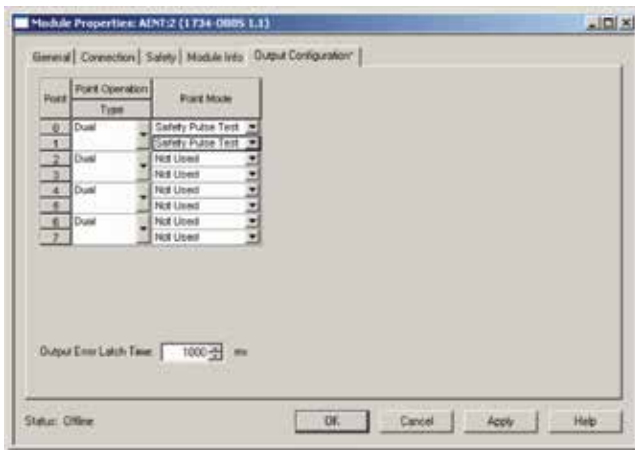

- Click OK.

### Programming

The Dual Channel Input Stop (DCS) instruction monitors dual-input safety devices whose main function is to stop a machine safely, for example, an E-stop, light curtain, or safety gate. In this example, it is being used to monitor a light curtain.

The DCS instruction monitors dual-input channels for consistency (Equivalent – Active High) and detects and traps faults when the inconsistency is detected for longer than the configured Discrepancy Time (ms).

The automatic restart type allows the DCS output (O1) to reset automatically after a demand. The manual action typically required for safety is provided in rung 1 to reset the safety output enable.

Input Status typically represents the channel status of the two input channels. In this example, the 'Combined Input Status' bit goes LO if any of the 8 input channels has a fault.

In this example, the DCS reset acts as a fault reset. Even when configured for automatic restart, a reset is required to recover from a fault.

The output (O1) of the DCS is used as a safety interlock in the seal-in rung to drive the output enable tag. If the DCS output drops out, so does the output enable, and it will remain off until a manual reset action is carried out.

The Configurable Redundant Output (CROUT) instruction controls and monitors redundant outputs. Essentially this instruction verifies that feedback follows the safety outputs appropriately. For the negative feedback used in this example; if the outputs are HI, the feedback should be LO and vice versa. In this example, the feedback has 500ms to change to the proper state. Since only a single feedback circuit is being used, the feedback tag is used for both Feedback 1 and 2.

The two (2) output tags from the CROUT instruction are used to drive the contactor outputs on the 1734-OB85 module.

# Safety Function Documents: GuardLogix

## Light Curtain GuardLogix® Controller

Safety Rating: PLe, Cat. 4 to EN ISO 13849.1 2008

### Programming cont.

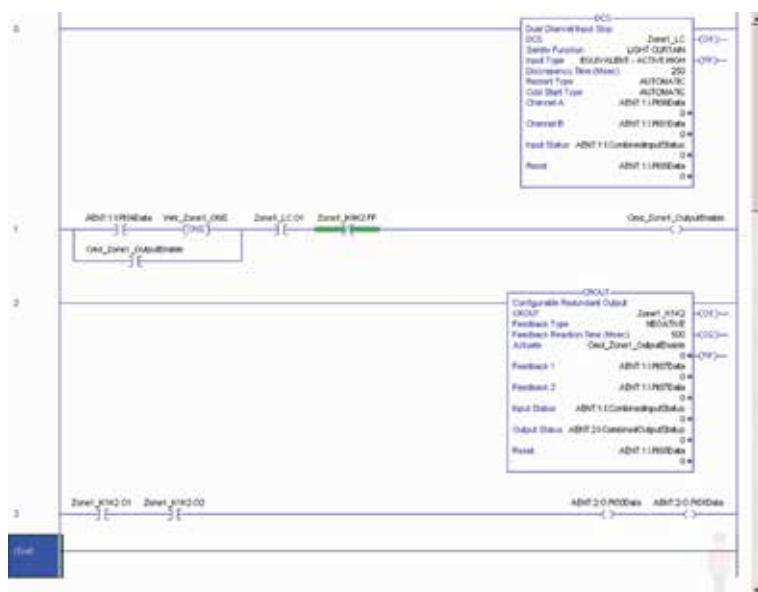

### Falling Edge Reset

ISO 13849-1 stipulates that instruction reset functions must occur on falling edge signals. To comply with this requirement, add a One Shot Falling instruction to the rung immediately preceding the Cmd\_Zone1\_OutputEnable rung. Then use the OSF instruction Output Bit tag as the reset bit for the following rung. The Cmd\_Zone1\_OutputEnable is still used to enable the CROUT instruction.

The modified code appears below in rungs 1 and 2.

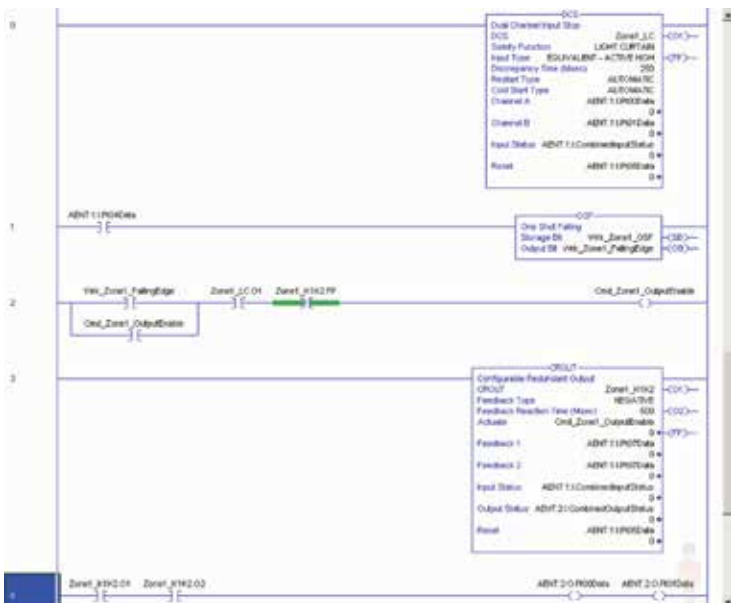

# Safety Function Documents: GuardLogix

## Light Curtain GuardLogix® Controller

Safety Rating: PLe, Cat. 4 to EN ISO 13849.1 2008

### Calculation of the Performance Level

When configured correctly, this Light Curtain emergency stop safety function can achieve a safety rating of PLe, Cat. 4 according to EN ISO 13849.1 2008.

The Functional Safety Specifications of the project call for a Performance Level on PLd (minimum) and a structure of Cat 3 (minimum). A PFHd of less than 1.0 E-06 for the overall safety function is required for PLd.

The individual subsystem values are shown below.

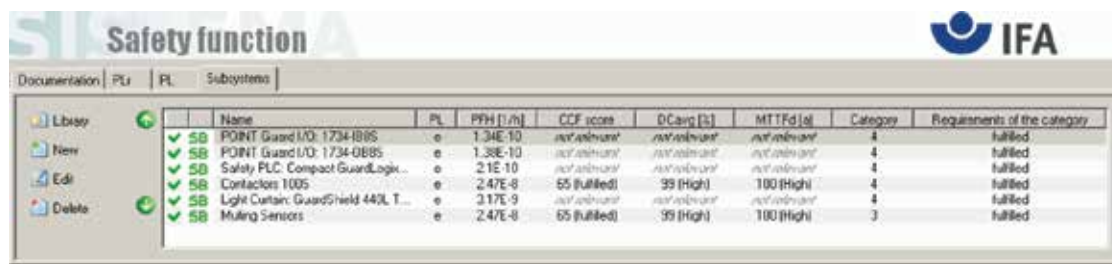

Name	PL	PFH [1/h]	CCF score	DCavg [s]	MTTFd [a]	Category	Requirements of the category
POINT Guard I/O: 1734-IB8S	e	1.34E-10	not fulfilled	not fulfilled	not fulfilled	4	fulfilled
POINT Guard I/O: 1734-OB8S	e	1.38E-10	not fulfilled	not fulfilled	not fulfilled	4	fulfilled
Safety PLC: Compact GuardLogix...	e	2.1E-10	not fulfilled	not fulfilled	not fulfilled	4	fulfilled
Contactors 100S	e	2.47E-8	65 (fulfilled)	99 (High)	100 (High)	4	fulfilled
Light Curtain: GuardShield 440L T...	e	3.17E-9	not fulfilled	not fulfilled	not fulfilled	4	fulfilled
Muting Sensors	e	2.47E-8	65 (fulfilled)	99 (High)	100 (High)	3	fulfilled

The overall safety function value is shown below.



Determine PL from subsystems

Performance Level (PL): e PFH [1/h]: 5.3E-8

The LC safety function can be modeled as shown in the following safety related block diagram:

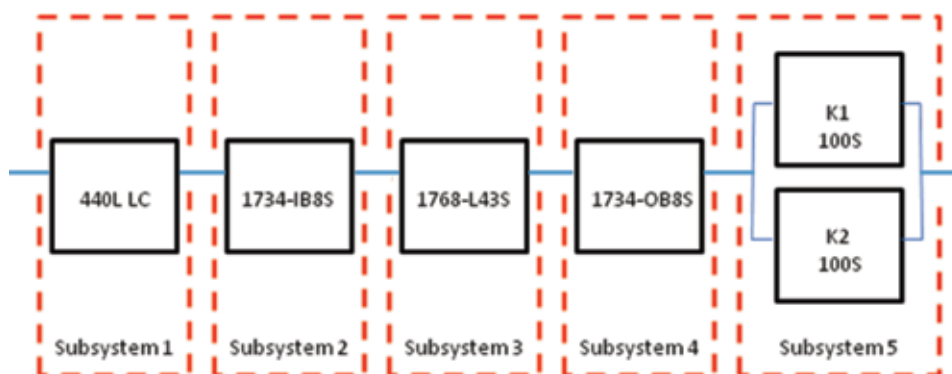

# Safety Function Documents: GuardLogix

## Light Curtain GuardLogix® Controller

Safety Rating: PL<sub>e</sub>, Cat. 4 to EN ISO 13849-1 2008

### Calculation of the Performance Level cont.

Calculations are based on 1 operation of the light curtain per hour; therefore 8,760 operations of contactors per year.

The measures against Common Cause Failure (CCF) are quantified using the scoring process outlined in Annex F of ISO 13849-1. For the purposes of the PL calculation, the required score of 65 needed to fulfill the CCF requirement is considered to be met. The complete CCF scoring process must be done when implementing this example.

SB Light Curtain: GuardShield 440L Type 4 - Single	
PL	e
PFH [1/h]	3.17E-9
Cat.	4
MTTFd [a]	<i>not relevant</i>
DCavg [%]	<i>not relevant</i>
CCF	<i>not relevant</i>

SB POINT Guard I/O: 1734-IB8S	
PL	e
PFH [1/h]	1.34E-10
Cat.	4
MTTFd [a]	<i>not relevant</i>
DCavg [%]	<i>not relevant</i>
CCF	<i>not relevant</i>

SB Safety PLC: Compact GuardLogix 1768	
PL	e
PFH [1/h]	2.1E-10
Cat.	4
MTTFd [a]	<i>not relevant</i>
DCavg [%]	<i>not relevant</i>
CCF	<i>not relevant</i>

SB POINT Guard I/O: 1734-OB8S	
PL	e
PFH [1/h]	1.38E-10
Cat.	4
MTTFd [a]	<i>not relevant</i>
DCavg [%]	<i>not relevant</i>
CCF	<i>not relevant</i>

SB Contactors 100S	
PL	e
PFH [1/h]	2.47E-8
Cat.	4
MTTFd [a]	100 (High)
DCavg [%]	99 (High)
CCF	65 (fulfilled)

# Safety Function Documents: GuardLogix

## Light Curtain GuardLogix® Controller

Safety Rating: PLe, Cat. 4 to EN ISO 13849.1 2008

### Verification and Validation Plan

Verification and Validation play an important role in the avoidance of faults throughout the safety system design and development process. ISO/EN 13849-2 sets the requirements for verification and validation. It calls for a documented plan to confirm all the Safety Functional Requirements have been met.

Verification is an analysis of the resulting safety control system. The Performance Level (PL) of the safety control system is calculated to confirm it meets the Required Performance Level (PLr) specified. The SISTEMA software tool is typically utilized to perform the calculations and assist with satisfying the requirements of ISO 13849-1.

Validation is a functional test of the safety control system to demonstrate that it meets the specified requirements of the safety function. The safety control system is tested to confirm all of the safety related outputs respond appropriately to their corresponding safety related inputs. The functional test should include normal operating conditions in addition to potential fault inject of failure modes. A checklist is typically used to document the validation of the safety control system.

Validation of software development is a process in which similar methodologies and techniques that are used in hardware development are deployed. Faults created through poor software development process and procedure are systemic in nature rather than faults associated with hardware which are considered as random.

*Prior to validating the GuardLogix Safety System, it is necessary to confirm the safety system and safety application program have been designed in accordance with the GuardLogix System Safety Reference Manual (1756-RM093) and the GuardLogix Application Instruction Safety Reference Manual (1756-RM095).*



# Safety Function Documents: GuardLogix

## Light Curtain GuardLogix® Controller

Safety Rating: PLe, Cat. 4 to EN ISO 13849.1 2008

### GuardLogix Light Curtain Safety Function Verification and Validation Checklist

General Machinery Information			
Machine Name / Model Number			
Machine Serial Number			
Customer Name			
Test Date			
Tester Name(s)			
Schematic Drawing Number			
Controller Name			
Safety Signature ID			
Safety Network Number(s)			
RSLogix5000 Software Version			
Safety Control System Modules	GuardLogix Modules	Firmware Version	
GuardLogix Safety Controller	1768-L43S		
CompactLogix Ethernet Bridge	1768-ENBT		
POINT I/O Ethernet Adapter	1734-AENT		
POINT I/O Input Modules	1734-IB8S		
POINT I/O Output Modules	1734-OB8S		
GuardLogix Safety System Configuration and Wiring Verification			
Test Step	Verification	Pass/Fail	Changes/Modifications
1	Verify the safety system has been designed in accordance with the GuardLogix System Safety Reference Manual 1756-RM093.		
2	Verify the safety application program has been designed in accordance with the GuardLogix Application Instruction Safety Reference Manual 1756-RM095.		
3	Visually inspect the safety system network and I/O is wired as documented in the schematics.		
4	Visually inspect the RSLogix 5000 program to verify that the safety system network and I/O module configuration is configured as documented.		
5	Visually inspect the RSLogix 5000 application program to verify suitable safety certified instructions are utilized. The logic is readable, understandable and testable with the aid of clear comments.		
6	All input devices are qualified by cycling their respective actuators. Monitor the status in the RSLogix 5000 Controller Tags window.		
7	All output devices are qualified by cycling their respective actuators. Monitor the status in the RSLogix 5000 Controller Tags window.		
Normal Operation Verification - The GuardLogix safety system properly responds to all normal Start, Stop, Enabling and Reset Commands			
Test Step	Verification	Pass/Fail	Changes/Modifications
1	Initiate a Start Command. Both contactors should energize for a normal machine run condition. Verify proper machine status indication and RSLogix 5000 safety application program indication.		
2	Initiate a Stop Command. Both contactors should de-energize for a normal machine Stop condition. Verify proper machine status indication and RSLogix 5000 safety application program indication.		
3	While Running, interrupt the light curtain. Both contactors should remain de-energized and open for a normal safe condition. Verify proper machine status indication and RSLogix 5000 safety application program indication.		
4	While Stopped, interrupt the light curtain and initiate a Start Command. Both contactors should remain de-energized and open for a normal safe condition. Verify proper machine status indication and RSLogix 5000 safety application program indication. Repeat for all light curtains.		
5	Initiate Reset Command. Both contactors should remain de-energized. Verify proper machine status indication and RSLogix 5000 safety application program indication.		

# Safety Function Documents: GuardLogix

## Light Curtain GuardLogix® Controller

Safety Rating: PLe, Cat. 4 to EN ISO 13849.1 2008

### Abnormal Operation Verification -

The GuardLogix safety system properly responds to all foreseeable faults with corresponding diagnostics.  
Light Curtain Input Tests

Test Step	Validation	Pass/Fail	Changes/Modifications
1	While Running, remove the Channel 1 wire from the Safety I/O. Both contactors should de-energize. Verify proper machine status indication and RSLogix 5000 safety application program indication. Verify unable to reset and restart with fault. Restore Channel 1 and repeat for Channel 2.		
2	While Running, short Channel 1 of the Safety I/O to +24VDC. Both contactors should de-energize. Verify proper machine status indication and RSLogix 5000 safety application program indication. Verify unable to reset and restart with fault. Restore Channel 1 and repeat for Channel 2.		
3	While Running, short Channel 1 of the Safety I/O to (-) 0VDC. Both contactors should de-energize. Verify proper machine status indication and RSLogix 5000 safety application program indication. Verify unable to reset and restart with fault. Restore Channel 1 and repeat for Channel 2.		
4	While Running, short Channels 1 & 2 of the Safety I/O. Both contactors should de-energize. Verify proper machine status indication and RSLogix 5000 safety application program indication. Verify unable to reset and restart with fault. Restore Channel 1 & 2 wiring.		
<b>GuardLogix Controller and Network Tests</b>			
Test Step	Validation	Pass/Fail	Changes/Modifications
1	While Running, remove the Ethernet network connection between the Safety I/O and the controller. All contactors should de-energize. Verify proper machine status indication and I/O Connection Status in the RSLogix 5000 safety application program.		
2	Restore the Safety I/O module network connection and allow time to reestablish communication. Verify the Connection Status Bit in the RSLogix 5000 safety application program. Repeat for all Safety I/O connections.		
3	While Running, switch the controller out of Run Mode. All contactors should de-energize. Return key switch back to Run Mode, all contactors should remain de-energized. Verify proper machine status indication and RSLogix 5000 safety application program indication.		
<b>Safety Contactor Output Tests</b>			
Test Step	Validation	Pass/Fail	Changes/Modifications
1	Initiate a Start Command. Both contactors should energize for a normal machine run condition. Verify proper machine status indication and RSLogix 5000 safety application program indication.		
2	While Running, remove the contactor feedback from the Safety I/O. All contactors should remain energized. Initiate a Stop command and attempt a Reset command. The system should not Restart or Reset. Verify proper machine status indication and RSLogix 5000 safety application program indication.		
3	While Running, short the contactor feedback to the Safety I/O. All contactors should remain energized. Initiate a Stop command and attempt a Reset command. The system should not Restart or Reset. Verify proper machine status indication and RSLogix 5000 safety application program indication.		

# Safety Function Documents: GuardLogix

## Light Curtain GuardLogix® Controller

Safety Rating: PLe, Cat. 4 to EN ISO 13849.1 2008

### Additional Resources

For more information about the products used in this example refer to these resources.

Resource	Description
Compact GuardLogix Controllers User Manual, Publication <b><u>1768-UM002</u></b>	Provides information on configuring, operating, and maintaining Compact GuardLogix controllers.
POINT Guard I/O Safety Modules Installation and User Manual, Publication <b><u>1734-UM013</u></b>	Provides information on installing, configuring, and operating POINT Guard I/O Modules.
GuardLogix Controller Systems Safety Reference Manual, Publication <b><u>1756-RM093</u></b>	Contains detailed requirements for achieving and maintaining safety ratings with the GuardLogix controller system.
GuardLogix Safety Application Instruction Set Reference Manual, Publication <b><u>1756-RM095</u></b>	Provides detailed information on the GuardLogix Safety Application Instruction Set.
Safety Accelerator Toolkit for GuardLogix Systems Quick Start Guide, Publication <b><u>IASIMP-QS005</u></b>	Provides a step-by-step guide to using the design, programming, and diagnostic tools in the Safety Accelerator Toolkit.

You can view or download publications at <http://www.rockwellautomation.com/literature>. To order paper copies of technical documentation, contact your local Allen-Bradley® distributor or Rockwell Automation sales representative.

# Safety Function Document

## Disclaimer

The information contained in this and any related publications is intended as a guide only. Every care has been taken to ensure that the information given is accurate at time of publication.

Neither NHP nor any of the manufacturers portrayed in this and any related publications accept responsibility for any errors or omissions contained therein nor any misapplications resulting from such errors or omissions.

Risk assessments should be conducted by authorized persons. The purchaser and installer are responsible for ensuring the safety system(s) incorporating these products complies with all current regulations and applicable standards.

Products are subject to change without notice and may differ from any illustration(s) provided. All products offered for sale are subject to NHP standard Conditions of Sale, a copy of which is available on application.