

L4188A,B; L4189A,B; L6188A-C; L6189A-C Aquastat® Controllers

PRODUCT DATA

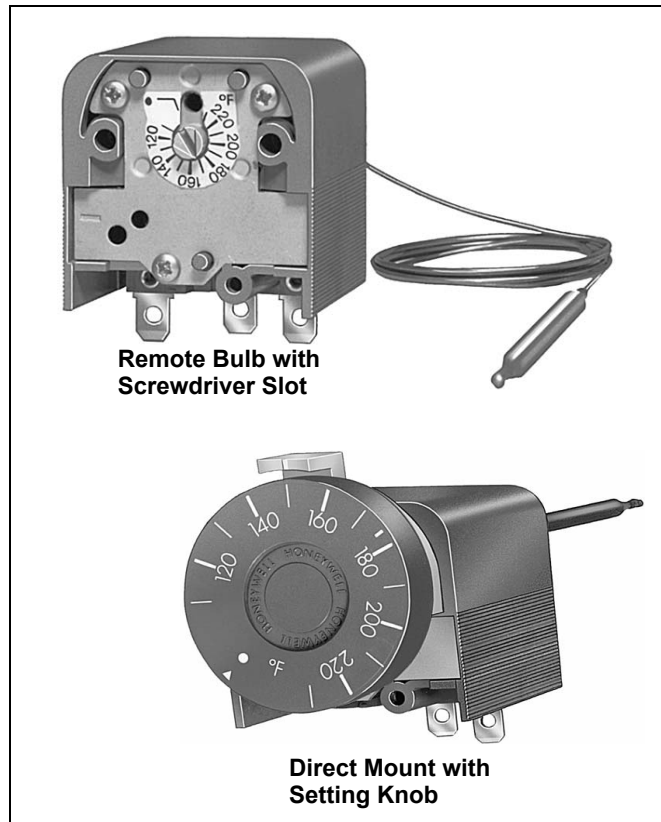

FEATURES

- L4188 and L4189 provide spst switching for high and low limit control.
- L6188 and L6189 provide spst switching for low limit and circulator control.
- L4188, L6188 models are direct-mounted.
- L4189, L6189 models are remote bulb.
- Diaphragm-operated switch breaks on temperature rise (spst and normally closed spdt contacts).
- Compact controller case for application flexibility.
- 3/16 in. diameter bulb for faster response.
- All models available with or without setting knob. Models without knob are adjusted with screwdriver.
- Choice of manual or auto reset. Auto reset models available with fixed or adjustable differential.
- 1/4 in. male quick-connects standard; combination screw and 1/4 in. quick-connects available.
- Field adjustable high or low limit stop available.
- Bracket for surface mounting available on remote bulb models.
- Capillary on remote bulb models available in several lengths.
- Immersion well with 1/2 in. NPT spud available as accessory.

APPLICATION

Aquastat® Controllers are bulb-type providing operating or limit control of water temperature in hot water heating systems and water heaters.

Contents

Application	1
Features	1
Specifications	2
Ordering Information	2
Installation	4
Wiring	6
Operation.....	7
Adjustments.....	7
Checkout	8



SPECIFICATIONS

Electrical Ratings:

	24 Vac	120 Vac	240 Vac
Full Load	2.0 A	8.0 A	5.1 A
Locked Rotor		48.0 A	30.6 A

Switching:

- Diaphragm-operated, snap-acting switch.
- L4188, L4189: Switch breaks on temperature rise to set point, remakes when temperature drops below set point and through differential.
- L6188, L6189: Switch breaks C-1 and makes C-2 on temperature rise to set point; switches back when temperature drops below set point and through differential.

Terminals:

1/4 in. male quick-connects standards. Options (specify when ordering):
Combination screw and 1/4 in. quick connects.
Separate grounding terminal.

Temperature Setting Range: 80° to 200° F (27° to 93° C), 110° to 230° F (43° to 110° C), and 160° to 280° F (71° to 138° C) available. Specify when ordering.
Temperature setting minus differential must be no more than 9° F (-13° C) below bottom of setting range.

Setting Scale: Marked every 20° F (-7° C), with subdivisions every 10° F (-12° C), includes OFF setting.

Limit Stop: Limits dial rotation beyond desired high or low limit temperature. Can be set at 5° F (2.5° C) intervals. Optional, available on models with knob only. Specify when ordering.

IMPORTANT

The specifications given in this publication do not include normal manufacturing tolerances. Therefore, this unit may not match the listed specifications exactly. Also, this product is tested and calibrated under closely controlled conditions, and some minor differences in performance can be expected if those conditions are changed.

MODELS: See Table 1.

Table 1. Aquastat® Controller Selection Guide

Model	Application	Switching	Mounting	Setting	Differential ^a
L4188A	High or low limit	Spst, breaks on temp. rise	Direct	Knob	7°, 14° or 22° F (-14°, -10° or -6° C), fixed ^a
L4188B				Screwdriver slot	
L4189A			Remote bulb	Knob	
L4189B				Screwdriver slot	
L6188A	Low limit and circulator	Spdt, breaks C-1, makes C-2 on temp. rise.	Direct	Knob	7°, 14° or 22° F (-14°, -10° or -6° C), fixed ^a , 7° - 18° F (-16° - -8° C), adjustable ^a
L6188B				Screwdriver slot	
L6188C				Manual reset	
L6189A			Remote bulb	Knob	7°, 14° or 22° F (-14°, -10° or -6° C), fixed ^a , 7° - 18° F (-16° - -8° C), adjustable ^a
L6189B				Screwdriver slot	
L6189C				Manual reset	

^a Specify when ordering.

ORDERING INFORMATION

When purchasing replacement and modernization products from your TRADELINE® wholesaler or distributor, refer to the TRADELINE® Catalog or price sheets for complete ordering number.

If you have additional questions, need further information, or would like to comment on our products or services, please write or phone:

1. Your local Honeywell Automation and Control Products Sales Office (check white pages of your phone directory).
2. Honeywell Customer Care
1885 Douglas Drive North
Minneapolis, Minnesota 55422-4386

In Canada—Honeywell Limited/Honeywell Limitée, 35 Dynamic Drive, Toronto, Ontario M1V 4Z9.

International Sales and Service Offices in all principal cities of the world. Manufacturing in Australia, Canada, Finland, France, Germany, Japan, Mexico, Netherlands, Spain, Taiwan, United Kingdom, U.S.A.

Ambient Temperature Range: 32° to 158° F (0° to 70° C).

Dimensions: See Fig. 1.

Mounting: Must be mounted in an enclosure that meets local electrical codes.

Sensing Bulb: Liquid-filled copper (See Fig. 1).

Direct: Unit mounts on immersion well at desired sensing location.

Underwriters Laboratories Inc. Component Recognized:
File No. MP466, Guide No. MBPR.

Remote bulb: Sensing bulb is inserted into immersion well at desired sensing location. Controller case mounts behind remote panel with two self-tapping M4 or No. 8 sheetmetal screws (supplied). Optional mounting bracket allows mounting on front of panel. Specify bracket when ordering.

Canadian Standards Association Listed: File No. LR62051-1.

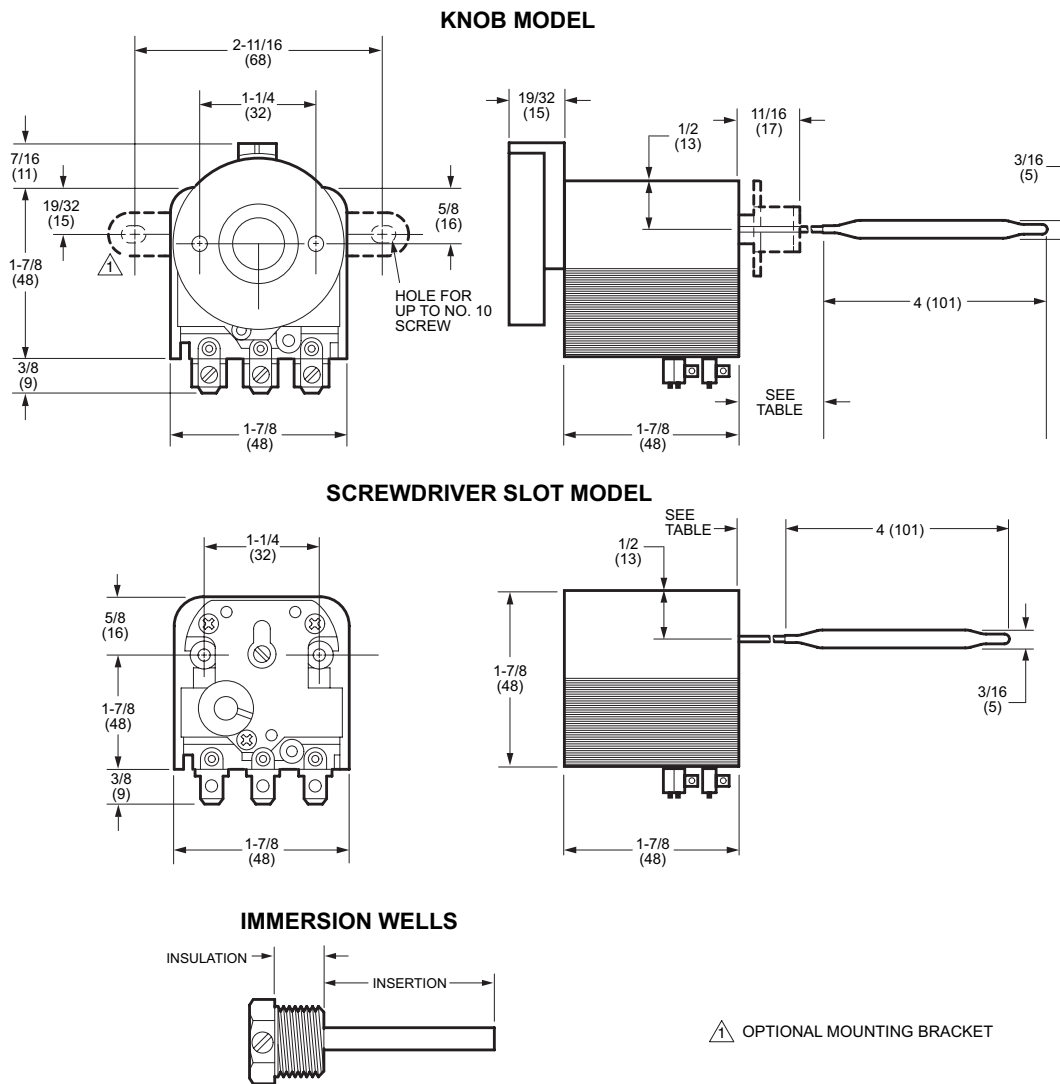

PART NO.	SPUD	INSULATION	INSERTION
45900409-003B	1/2 in. BSPT	1 in.	3-1/2 in.
45900409-009B	1/2 in. NPT	1-1/2 in.	3 in.
45900409-010B	3/4 in. NPT	1-1/2 in.	3 in.

MODEL	CAPILLARY LENGTH		MOUNTING
DIRECT MOUNT L4188, L5188	1-3/16 IN.	30 MM	USE IMMERSION WELLS SHOWN AT RIGHT
	2-5/16 IN.	50 MM	
REMOTE MOUNT L4189, L5189	39-3/8 IN.	1000 MM	USE IMMERSION WELLS SHOWN AT RIGHT OR CAPILLARY COMPRESSION FITTINGS
	50 IN.	1500 MM	
	78-11/16 IN.	2000 MM	

M25414

Fig. 1. Dimensions in in. [mm in brackets] of Aquastat Controller and Immersion Well.

Accessories (order separately):

Capillary compression fittings.

Part No. 104484A: 1/2 in. NPT spud.

Part No. 104484B: 3/4 in. NPT spud.

Immersion well: Pressure rating 255 psi [1760 kPa].

Part No. 45900409-003B: 1/2 in. BSPT spud, 1 in. insulation, 3-1/2 in. insertion.

Part No. 45900409-009B: 1/2 in. NPT spud, 1-1/2 in. insulation, 3 in. insertion.

Part No. 45900409-010B: 3/4 in. NPT spud, 1-1/2 in. insulation, 3 in. insertion.

Optional Specifications (Specify when ordering):

- Combination screw and 1/4 in. male quick-connect terminals.
- High or low limit stop (models with knob only).
- Mounting bracket (remote bulb models only).

INSTALLATION

When Installing This Product...

1. Read these instructions carefully. Failure to follow them could damage the product or cause a hazardous condition.
2. Check the ratings given in the instructions and on the product to make sure the product is suitable for your application.
3. Installer must be a trained, experienced service technician.
4. After installation is complete, check out product operation as provided in these instructions.

CAUTION

Disconnect power supply before wiring to avoid electrical shock or equipment damage. Terminal connections must be inside an enclosure that meets local electrical codes.

Location

The equipment manufacturer generally provides a tapping for insertion of the temperature controller sensing element. The tapping should be located at a point where average system temperature will be measured. Never locate the sensing element close to a hot or cold water inlet or a steam coil, or where the well's pressure rating will be exceeded.

Turn off power and, if the system is filled, drain to a point below the boiler tapping or wherever the sensing element is to be located. If no tapping is provided, prepare one, properly threaded, at the desired location.

If this is a remote bulb unit, the controller case can be mounted in a panel or, with the optional bracket, on any flat surface. Choose a location within reach of the sensing element. Allow for gradual bends and some slack in the capillary.

Mount the Immersion Well

1. Coat the well threads with a moderate amount of pipe dope, leaving two end threads bare. Teflon® tape may also be used.
2. Screw the immersion well into the tapping and tighten securely.

3. Refill the system. Check for and correct any leaks.

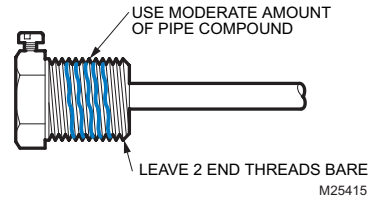

Fig. 2. Use good Piping Practice when Installing Immersion Well.

To Install Direct Mount Controller

1. Slide the sensing bulb all the way into the well. The metal collar around the capillary should slip into the well spud.
2. Line up the case so the setting indicator is on top.
3. Tighten the setscrew in the well spud snugly against the metal collar.

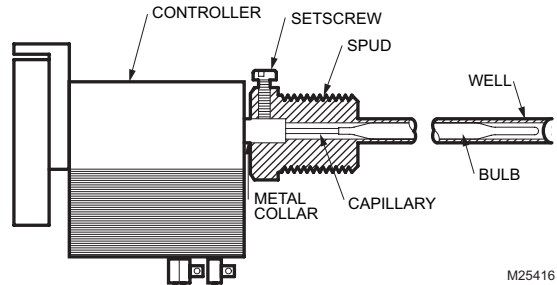

Fig. 3. The Direct Mount Model is held in place by the Setscrew in the Well Spud.

To Mount Remote Bulb Controller

Insert Sensing Bulb in Well

1. Slide sensing bulb into well. Make sure bulb rests against the bottom of the well. Don't bend the capillary where it connects to the bulb.
2. Hold bulb in place and tighten setscrew all the way down. It won't fit tight against the capillary, but it will keep the bulb from sliding out.

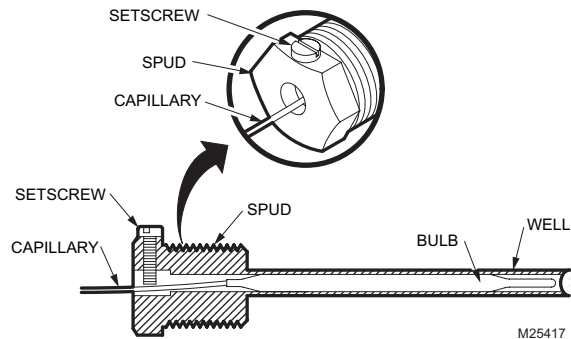

Fig. 4. The Setscrew keeps the Remote Sensing Bulb in the Well.

Mounting Behind Panel-Controller with Knob

NOTE: The panel can be up to 5/64 in. thick.

1. Uncoil capillary, starting at bulb. Avoid sharp bends or kinks in the capillary. Leave excess capillary loosely coiled below controller case.
2. Remove the setting knob by pulling straight off.
3. Remove the two screws that hold the setting indicator in place and remove the setting indicator (See Fig. 5).
4. ADJUSTABLE DIFFERENTIAL MODELS ONLY: Set differential. See Adjustment and Checkout section.
5. Using setting indicator as a template, mark and drill holes in the panel for the mounting screws and for the knob shaft.
6. Mount the controller behind, and the setting indicator in front of, the panel using the two screws removed earlier (See Fig. 5).
7. MODELS WITH TEMPERATURE LIMIT STOP ONLY: Adjust to desired setting, as described under "To Set Temperature Limit Stop," page 8.
8. Replace knob on shaft.

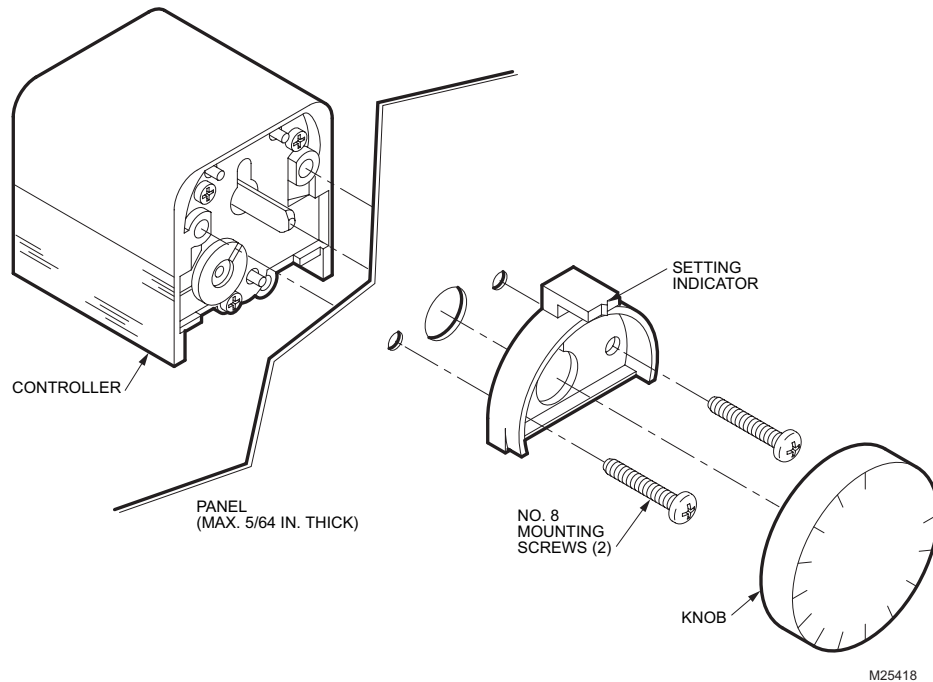
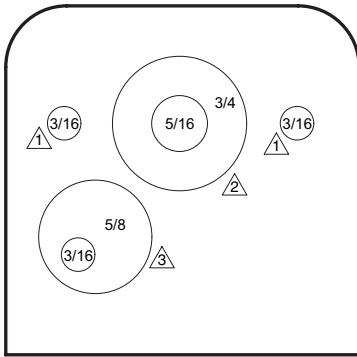

Fig. 5. The Mounting Screws hold the Setting Indicator and Controller in place.

Mounting Behind Panel-Controller with Screwdriver Slot

1. Mark and drill three holes in the panel, using the template in Fig. 6 as a guide.
2. MANUAL RESET MODELS ONLY: Drill a fourth hole to make the manual reset button accessible.
3. ADJUSTABLE DIFFERENTIAL MODELS ONLY: Drill a hole for the differential dial, if desired, Set the differential. See Adjustment and Checkout section.
4. Hold controller against back of panel with terminals pointed down and fasten with two No. 8 sheetmetal screws (not supplied) (Refer to Fig. 6).

MOUNTING TEMPLATE



- ⚠ DRILL 2 MOUNTING SCREW HOLES.
- ⚠ DRILL HOLE FOR SLOTTED SHAFT. USE SMALL HOLE FOR SHAFT ONLY; LARGE HOLE SHAFT PLUS SETTING SCALE.
- ⚠ DRILL SMALL HOLE FOR MODEL WITH MANUAL RESET BUTTON OR LARGE HOLE FOR MODEL WITH DIFFERENTIAL ADJUSTMENT.

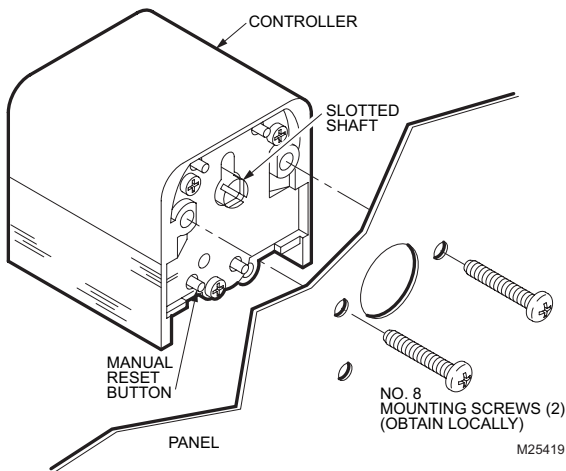

Fig. 6. Drill holes in the Panel as shown.

Mounting on Panel-Controller with Bracket

1. Using controller bracket as a template, mark and drill two holes in the panel.
2. Mount controller with terminals down.
3. Run capillary neatly along panel, avoiding sharp bends and interference with other components on the panel.
4. MODELS WITH TEMPERATURE LIMIT STOP ONLY: Adjust to desired setting, as described under "To Set Temperature Limit Stop," page 8.

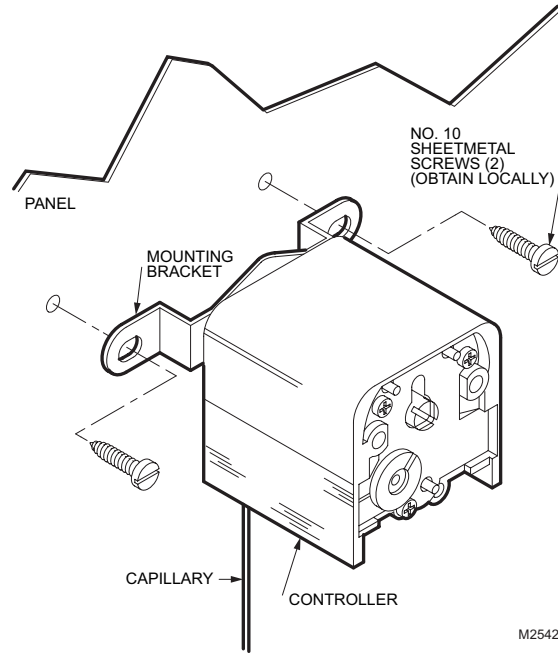
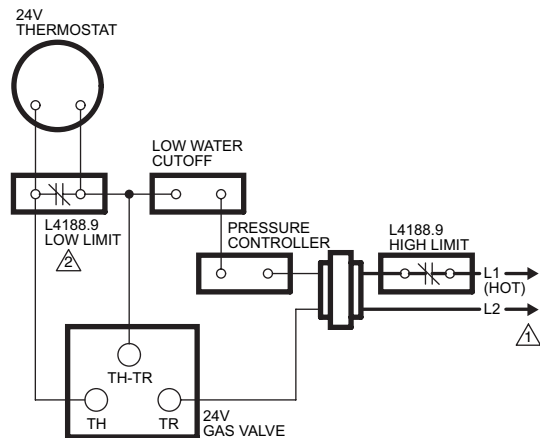

Fig. 7. The Controller with Bracket Mounts on the Front of the Panel.

WIRING

All wiring must comply with applicable codes and ordinances, Disconnect power before beginning wiring.

Connect as shown in equipment manufacturer's instructions, if provided. Otherwise, use the typical hookups shown (See Fig. 8) (refer to Figures 9 and 10).



- ⚠ POWER SUPPLY. PROVIDE DISCONNECT MEANS AND OVERLOAD PROTECTION AS REQUIRED.
- ⚠ USE L6188.9C (C-1 CONTACTS) IF MANUAL RESET IS REQUIRED.

M25421

Fig. 8. Low and High Limit Application on a Gas-Fired System with Domestic Hot Water.

OPERATION

As the liquid filling the sensing bulb and capillary expands and contracts, it moves a diaphragm. Movement of the diaphragm is transferred by a lever to the snap-acting switch in the controller.

High or Low Limit Action (L4188, L4189)

The normally closed C-1 contacts open on temperature rise to the set point, shutting off power to the controlled circuit. On auto recycle models, the switch closes C-1 after the temperature falls past the set point and through the differential.

Low Limit/Circulator Action (L6188, L6189)

The low limit is connected to the normally closed C-1 contacts, and the circulator to the normally open C-2 contacts. As long as the temperature at the sensing bulb is above set point, the circulator runs. If sensing bulb temperature falls past the set point and through the differential, the switch breaks C-2 to turn off the circulator, and makes C-1 to turn on the burner. When the temperature rises to the set point, C-2 makes to turn on the circulator, and C-1 breaks to turn off the burner.

On manual reset models, the reset button must be pushed before contacts C-1 will close (See Fig. 11).

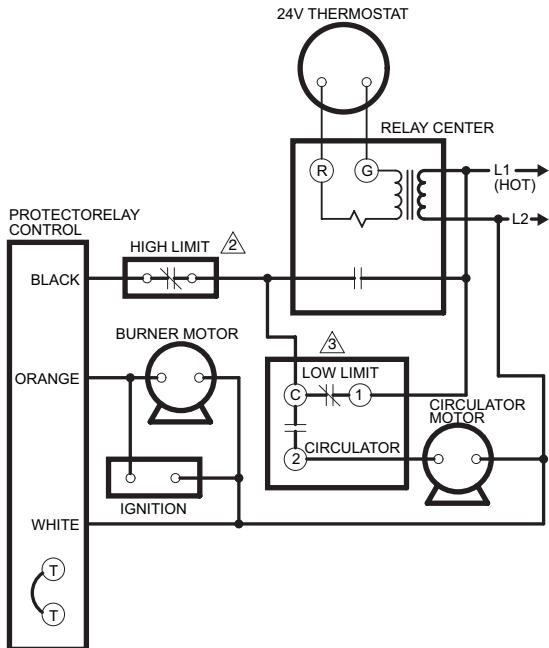

- ⚠ POWER SUPPLY. PROVIDE DISCONNECT MEANS AND OVERLOAD PROTECTION AS REQUIRED.
 - △ L4188 OR L4189 USED AS HIGH LIMIT.
 - ⊠ L6188 OR L6189 USED AS LOW LIMIT/CIRCULATOR CONTROLLER.
- M25422

Fig. 9. High Limit and Low Limit/Circulator Application in an Oil-Fired Hydronic System with domestic hot water.

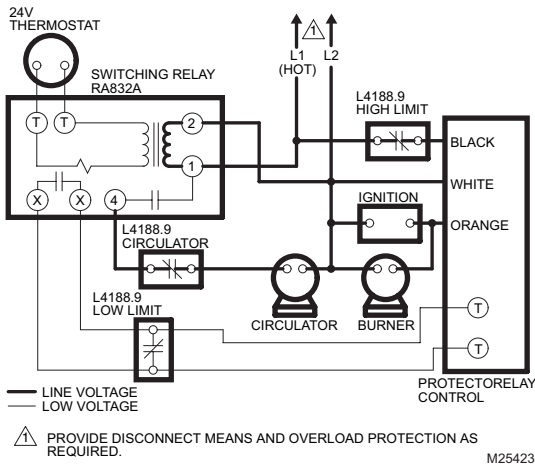

- ⚠ PROVIDE DISCONNECT MEANS AND OVERLOAD PROTECTION AS REQUIRED.
- M25423

Fig. 10. High Limit and Separate Low Limit and Circulator Application in an Oil-Fired Hydronic System with Domestic Hot Water.

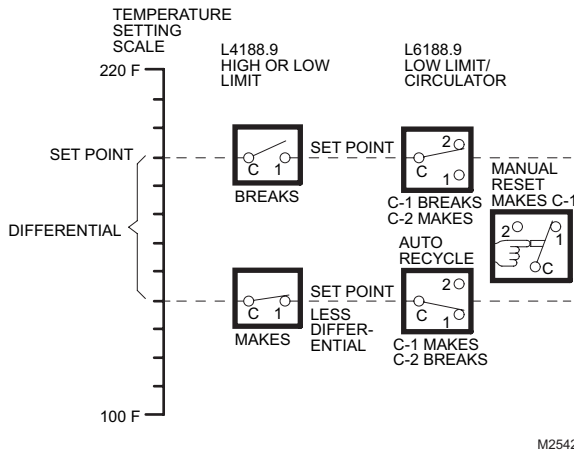

Fig. 11. Aquastat Controller Switch Action on Temperature Change.

ADJUSTMENTS

To Set Temperature

KNOB MODELS

Line up the desired temperature setting with the temperature setting indicator behind the knob.

SCREWDRIVER SLOT MODELS

Line up the pointer on the shaft with the desired temperature setting printed on the case.

To Set Adjustable Differential (if provided)

Use a screwdriver to turn the differential dial until the slot molded into the case lines up with the desired degrees of differential.

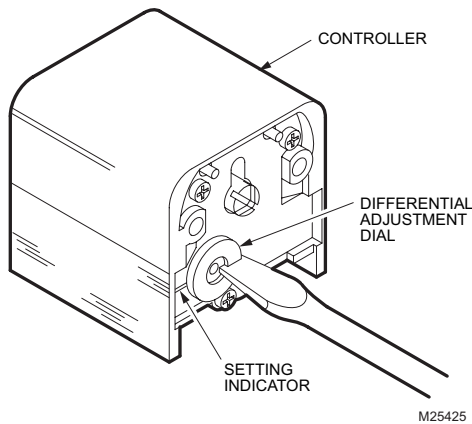

Fig. 12. Twist the Screwdriver Slightly to turn the Differential Dial.

To Set Temperature Limit Stop (if provided)

! CAUTION

Follow these instructions carefully to avoid placing the limit stop pointer on the wrong side of the setting indicator. In a high limit application, incorrect positioning of the pointer will cause system operation above the limit stop setting, potentially resulting in overheating or related conditions.

- Remove the knob.
- Turn the controller shaft all the way counterclockwise ↺ when setting a high limit. Turn it all the way clockwise ↻ when setting a low limit.
- Find the metal limit stop on the back of the knob.
- Lift the limit stop slightly with a pencil or screwdriver and push to move to desired setting.
- Read the setting from the front of the knob.
- Place the knob on the shaft.
- Turn the knob to make sure it: (1) turns through the desired adjustment range, and (2) stops at the limit setting. DO NOT FORCE.
- Return knob to desired setting.

Teflon® is a registered trademark for E.I. Du Pont De Nemours and Company.

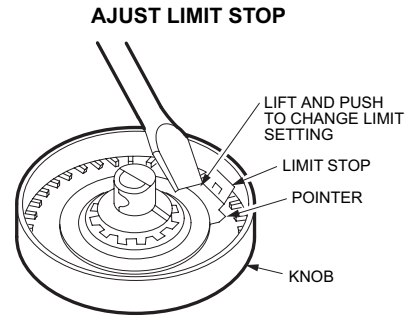

REPLACE KNOB ON SHAFT

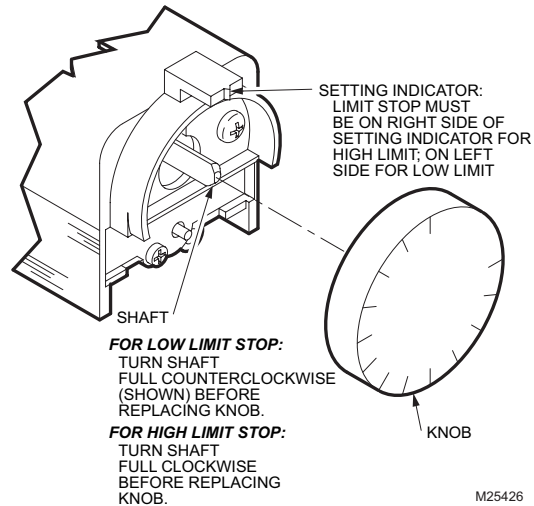

Fig. 13. Adjust the Limit Stop with a Screwdriver and check Orientation when Replacing Knob on Shaft.

CHECKOUT

Turn the system on and observe it through several cycles to make sure the controller operates as desired.

Automation and Control Solutions

Honeywell International Inc.
1985 Douglas Drive North
Golden Valley, MN 55422
customer.honeywell.com

Honeywell Limited-Honeywell Limitée
35 Dynamic Drive
Toronto, Ontario M1V 4Z9