

INSTRUCTIONS

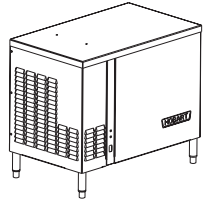

INFRARED
BOOSTER

INFRARED BOOSTER . . . Gas Water Heaters

MODEL

<i>IB57</i>	<i>ML-110898</i>
<i>IB140</i>	<i>ML-110899</i>
<i>IB235</i>	<i>ML-110861</i>
<i>IB290</i>	<i>ML-110862</i>



701 S. RIDGE AVENUE
TROY, OHIO 45374-0001

937 332-3000

www.hobartcorp.com

FORM 34070 Rev. C (10-99)

IMPORTANT FOR YOUR SAFETY

WARNING: IF THE INFORMATION IN THESE INSTRUCTIONS IS NOT FOLLOWED EXACTLY, A FIRE OR EXPLOSION MAY RESULT CAUSING PROPERTY DAMAGE, PERSONAL INJURY OR DEATH.

DO NOT STORE OR USE GASOLINE OR OTHER FLAMMABLE VAPORS AND LIQUIDS IN THE VICINITY OF THIS OR ANY OTHER APPLIANCE.

WHAT TO DO IF YOU SMELL GAS

- Do not try to light any appliance.
- Do not touch any electrical switch; do not use any phone in your building.
- Immediately call your gas supplier from a neighbor's phone. Follow the gas supplier's instructions.
- If you cannot reach your gas supplier, call the fire department.

INSTALLATION AND SERVICE MUST BE PERFORMED BY A QUALIFIED INSTALLER, SERVICE AGENCY, OR THE GAS SUPPLIER.



Installer: Affix these *Instructions* adjacent to the appliance.
Customer: Save these *Instructions* for future reference.

TABLE OF CONTENTS

IMPORTANT FOR YOUR SAFETY	2
GENERAL	4
Delivery Rates at 180°F.....	4
INSTALLATION	5
Unpacking.....	5
Installation Codes.....	5
Location	5
Clearance Dimensions.....	5
Leveling	5
Combustion / Ventilation Air	5
Venting Requirements	6
Acceptable Vent Piping	6
Gas Connection	9
Gas Pressure Specifications	9
Water Requirements	10
Plumbing Connections	10
Electrical Connections	12
Electrical Diagram	13
Start Up Procedures	14
Filling the Booster Piping	14
Checking the Circulator	14
Lighting the Heater	14
What To Do If You Smell Gas	14
Hot Surface Ignition Using the Robertshaw Gas Valve.....	15
To Turn Off Gas To Heater	15
OPERATION	16
MAINTENANCE	17
Lubrication	17
Vent System	17
Check Burner Flame	17
TROUBLESHOOTING.....	17
List of Replacement Parts	18
Service	20

Installation, Operation, and Care of INFRARED BOOSTER GAS WATER HEATERS

SAVE THESE INSTRUCTIONS

GENERAL

The Infrared Booster Gas Water Heaters (available for natural gas or propane) provide 180°F rinse water for commercial dishwashing machines. Health codes and NSF permit 180°F (minimum temperature) water to be used as a sanitizing rinse for utensils and dishware used in restaurants and food-serving operations. Water enters the gas booster water heater at the inlet water connection, circulates through the gas heat exchanger and stainless steel tank, and constantly maintains the 180°F minimum water temperature at the outlet connection. The table, *Delivery Rates @ 180°F*, indicates the maximum amount of hot water that can be delivered by the various Booster Heater models, depending on the incoming water temperature.

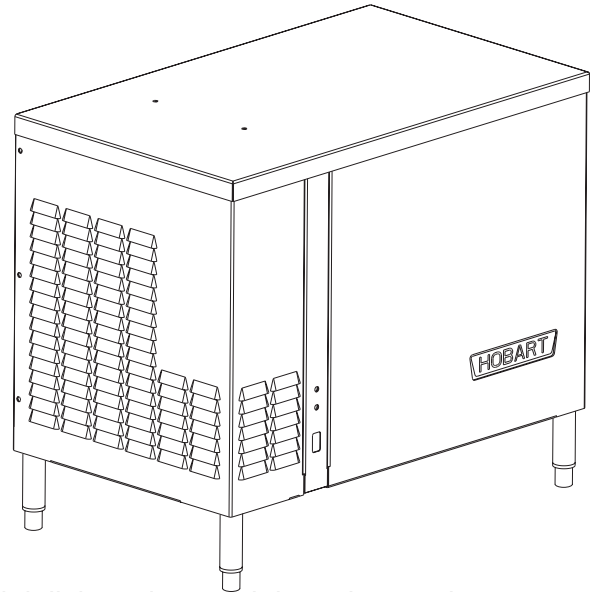

Rinse water volume requirements for various commercial dishwasher models and operating rates are available from your authorized Hobart dealer.

Model	Input (Btu/hr) Natural Gas	Input (Btu/hr) Propane	Tank Capacity (U.S. Gallons)	Width x Height x Depth (Inches)
IB57	57,000	57,000	9.5	25.375 x 30.125 x 19.50
IB140	140,000	140,000	9.5	28.375 x 32.125 x 22.25
IB235	235,000	235,000	17.0	36.875 x 32.125 x 22.25
IB290	290,000	280,000	17.0	36.875 x 32.125 x 22.25

DELIVERY RATES @ 180° F (assuming 80% efficiency)

Model	Input (Btu/hr)	Rate	Incoming Water Temperature				
			110° F	120° F	130° F	140° F	150° F
IB57	57,000 Natural or Propane	Gallons per Minute	1.30	1.52	1.82	2.28	3.04
		Gallons per Hour	78	91	109	137	182
IB140	140,000 Natural or Propane	Gallons per Minute	3.20	3.73	4.48	5.60	7.46
		Gallons per Hour	192	224	268	336	448
IB235	235,000 Natural or Propane	Gallons per Minute	5.37	6.27	7.52	9.40	12.54
		Gallons per Hour	322	376	451	564	752
IB290	290,000 Natural	Gallons per Minute	6.63	7.74	9.28	11.60	15.47
		Gallons per Hour	398	464	557	696	928
	280,000 Propane	Gallons per Minute	6.40	7.47	8.96	11.20	14.94
		Gallons per Hour	384	448	538	672	896

NOTE: For altitudes above 5000 feet, contact Hobart Product Service, phone (937) 332-2525, Warewash Technical Support.

INSTALLATION

UNPACKING

Immediately after unpacking, check for possible shipping damage. If the Booster Heater is found to be damaged after unpacking, save the packaging material and contact the carrier within 15 days of delivery.

Prior to installation, test the electrical service to assure that it agrees with the specifications on the data plate located on the left-front panel of the booster heater. Be sure that the type of gas supplied to the machine (natural gas or propane) is the same as indicated on the data plate.

INSTALLATION CODES

Installation must be in accordance with state and local codes, or in the absence of local codes, with the National Fuel Gas Code, ANSI Z223.1 (latest edition) and the National Electrical Code, ANSI/NFPA 70 (latest edition). In Canada, the installation standards are: CAN/CGA B149.1, CAN/CGA B149.2, and CSA C22.2 No.1 (latest editions).

LOCATION

Locate the IB Series Booster Water Heater so that the required clearance dimensions are maintained.

Keep the appliance area clear and free from combustible materials, gasoline and other flammable vapors and liquids. The booster heater should not be located in an area where water leakage will result in damage to the area adjacent to it or to lower floors of the structure. Where such areas cannot be avoided, install a suitable catch pan, adequately drained, under the heater. The pan must not restrict combustion air flow. Do not install heater directly on carpeting.

CLEARANCE DIMENSIONS

FLOOR	TOP	LEFT SIDE		RIGHT SIDE		FRONT	BACK	VENT	
		Allowable	Recommended for Service	Allowable	Recommended for Service			Combustible Construction	Non-Combustible Construction
6" *	0"	2"	20"	2"	10"	Alcove**	7"	6" Horizontal 1/2" Vertical	1/2" Horizontal 1/2" Vertical

* Approved for installation on combustible flooring (6" legs provide required clearance).

** A front clearance of at least 24" is recommended for adequate service of controls.

LEVELING

Four legs are welded to the bottom corners of the frame to provide the required six-inch floor clearance. Adjustable feet at the bottom of the four legs should be rotated in or out as required to level the booster heater front-to-back and side-to-side in its final location.

COMBUSTION / VENTILATION AIR

CAUTION: Combustion air must not be contaminated by corrosive chemical fumes which can damage the heater.

An adequate supply of air for proper combustion and ventilation must be provided in accordance with the National Fuel Gas Code, ANSI Z223.1, or applicable building codes. Do not obstruct the flow of combustion and ventilation air to the heater.

VENTING REQUIREMENTS

WARNING: PROVIDE A SCREEN OR BARRIER TO PREVENT PERSONAL INJURY IN AREAS WHERE INADVERTENT PERSONNEL CONTACT WITH THE HOT VENT PIPE CAN OCCUR.

Models IB57 and IB140 are Category IV (positive flue pressure, excessive condensate, and flue gas temperature at the heater outlet approximately 330°F). Models IB235 and IB290 are Category III (positive flue pressure, not excessive condensate, and flue gas temperature at the heater outlet approximately 530°F). The vent outlet on the booster heater is 3 inches in diameter. Models IB57 and IB140 require 3 inch minimum vent pipe throughout. Models IB235 and IB290 require 4 inch minimum vent pipe; the 3 inch adjustable vent pipe elbow and the 3 inch to 4 inch vent pipe adapter (provided on IB235 and IB290) are to be installed at the vent outlet of the booster heater (Fig. 1). On all models, 1/4 inch per foot minimum incline must be maintained.

Models IB235 & IB290 Only

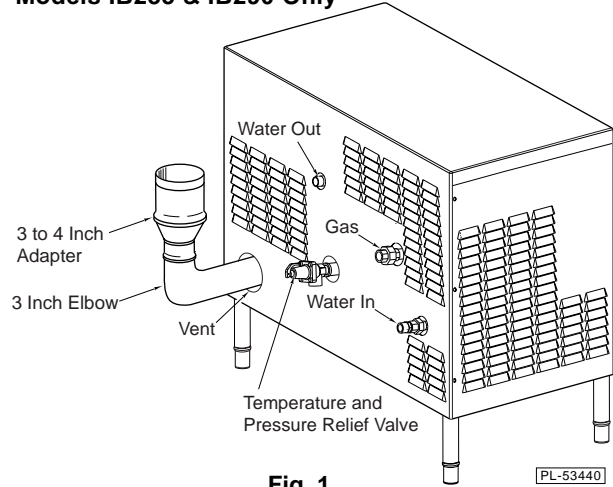

Fig. 1

Vent piping must be one of the types mentioned in this manual and must be properly installed according to the vent pipe manufacturer's instructions. Each vent joint must be properly sealed and secured so it stays in place.

ACCEPTABLE VENT PIPING

MANUFACTURER	MODEL	MATERIAL SPECIFICATION	TERMINATION Part Name	IB57 or IB140 TERMINATION Part Number	IB235 or IB290 TERMINATION Part Number
Heat-Fab Inc. 38 Haywood St. Greenfield, MA 01301	Saf-T-Vent	AL 29-4C* Stainless Steel	Tee Rain Cap Mitre / Straight	7390TEE 5300C1 7390GC	7490TEE 5400C1 --
Z-Flex US, Inc. 20 Commerce Park North Bedford, NH 03110	Z-Vent	AL 29-4C* Stainless Steel	Tee Rain Cap Termination Box	#02SVSTTX-3 #02VRSRCX03 #02SVSRTX-3	#02SVSTTX-4 #02VRSRCX04 #02SVSRTX-4

* AL 29-4C is a registered trademark of Allegheny Ludlum Corp.

Per the National Fuel Gas Code, ANSI Z223.1, the heater must be vented in one of three ways:

1. Into the exhaust system (Fig. 2). The vent pipe must not penetrate the filter. When the heater is vented into the exhaust system, an electrical interlock must be provided (by others) to allow the flow of gas to the booster heater burner ONLY when the exhaust system is functioning. Refer to APS1 and APS2 on the wiring diagram in the control box accessed by removing the left side panel (also refer to pages 12 and 13).
2. Through the sidewall, or the ceiling (Fig. 3). Type B-1 vent pipe (4 inch minimum diameter for IB57 and IB140, 5 inch minimum diameter for IB235 and IB290) may be used when venting vertically, provided a one inch minimum clearance to combustible construction is maintained and the termination above the roof uses a listed wind cap.
3. Freely vented into the room or space where it is installed (Fig. 4), provided that:
 - a. A mechanical exhaust system is present in the kitchen,
 - b. The flue outlet of the booster water heater is at least 36 inches vertically and 6 inches horizontally distant from any surface other than the booster / or dishwasher, and
 - c. Any or all gas fired equipment is installed so the total BTU input rating of the unvented gas appliance(s) divided by the total cubic feet of the room area (including any areas adjacent that cannot be closed off) does not exceed 20 BTU per hour per cubic foot.

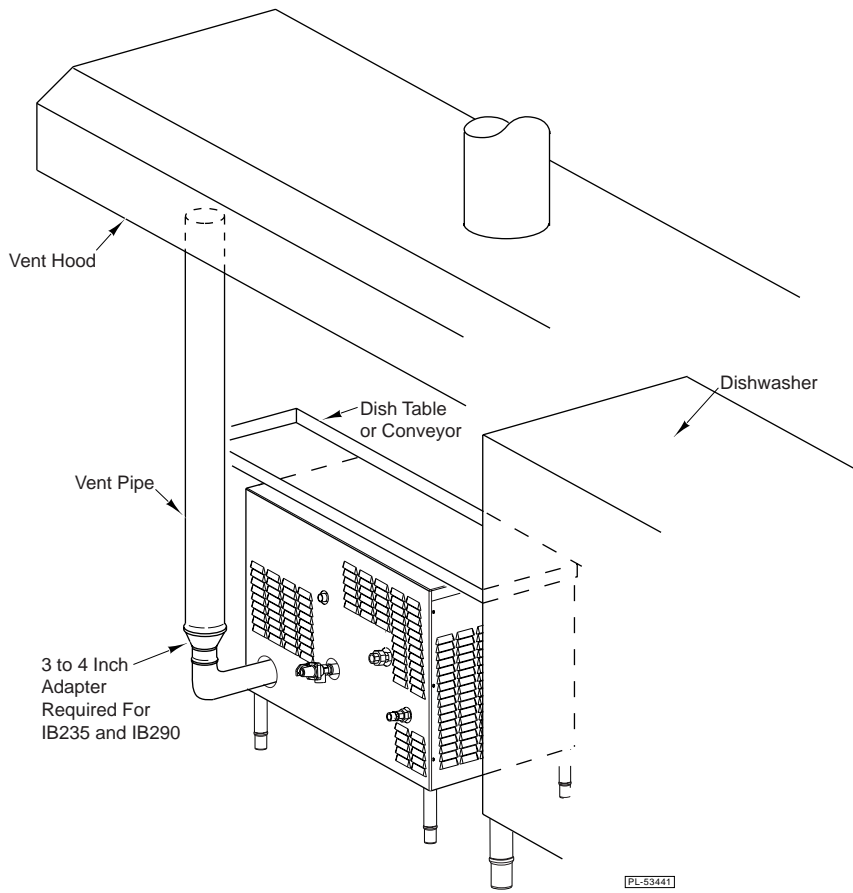

Fig. 2

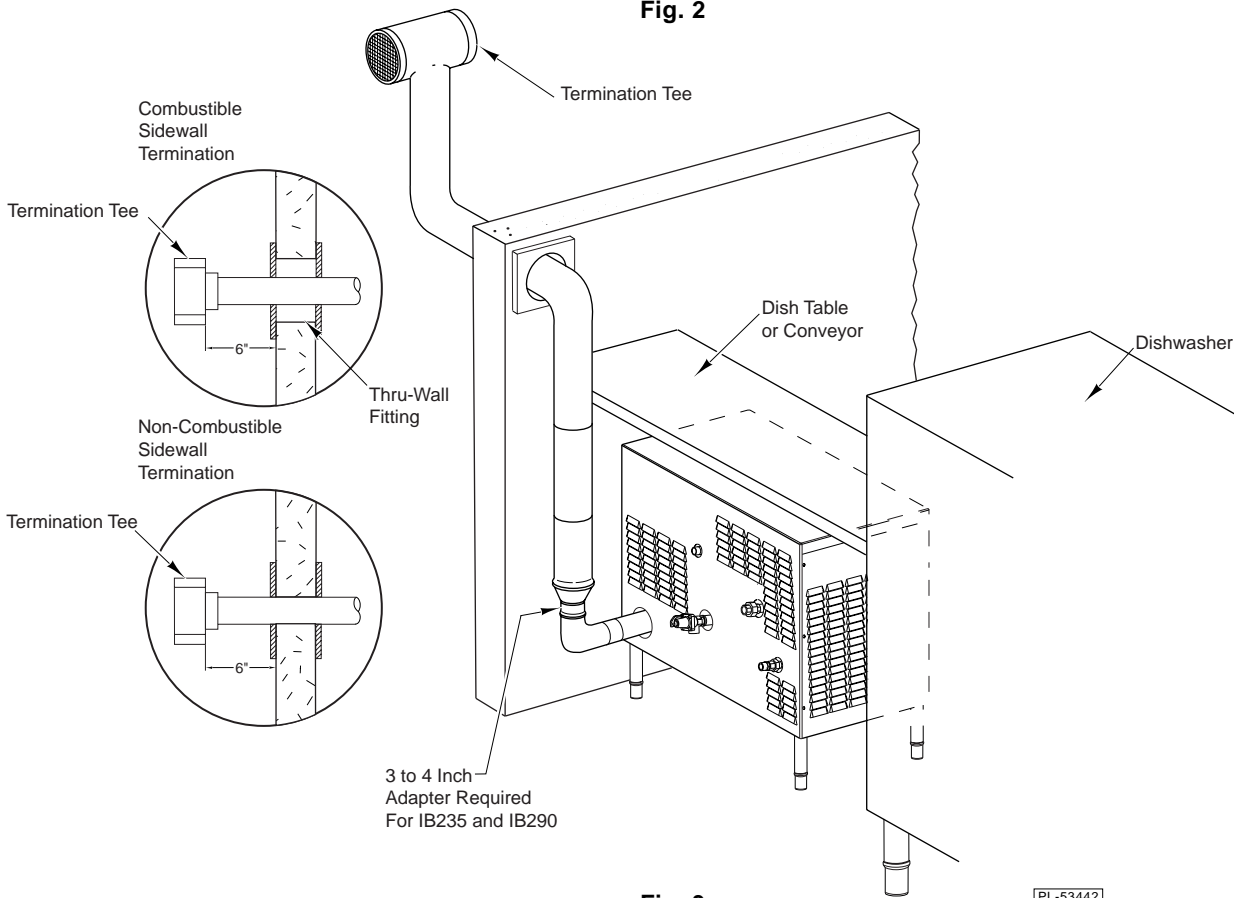

Fig. 3

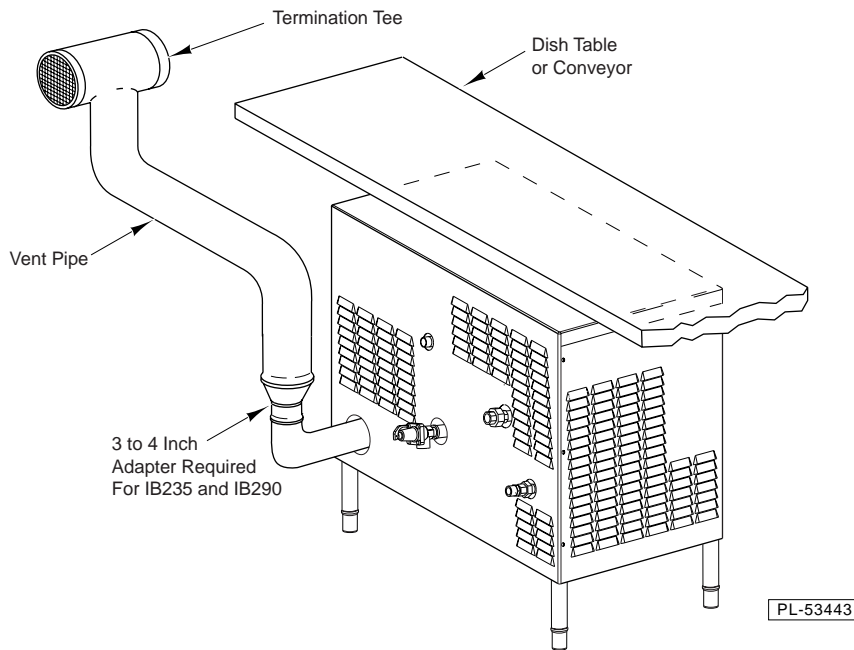

Fig. 4

All horizontal runs of the vent pipe shall have a minimum rise of $\frac{1}{4}$ " per foot of length and should be supported every 5 feet or less (for Canada, every 3 feet) and at every elbow.

For horizontal venting of models IB57 and IB140, the total length of 3-inch diameter vent pipe can be up to 70 feet with up to four 90° elbows and one termination vent. For horizontal venting of models IB235 or IB290, the total length of 4-inch diameter vent pipe can be up to 70 feet with up to four 90° elbows and one termination vent. For each additional elbow, reduce the total pipe length by 10 feet. The minimum length is 2 feet. For vertical venting: The maximum length of 3" or 4" diameter vent pipe described above should be followed; the same requirements for elbows and termination vent apply; the minimum length for vertical venting is 5 feet.

For sidewall venting, locate the heater as close as possible to the wall being used. The maximum and minimum wall thickness is determined by the wall thimble available from the vent manufacturer. Refer to the vent manufacturer's installation instructions.

When a draft hood is used, it must be in the same atmospheric pressure zone as the combustion air inlet of the booster water heater.

Additional requirements when venting through a sidewall:

- The vent terminal shall be located at least three feet above any forced air inlet located within ten feet; or at least four feet below, four feet horizontally from, or one foot above any door, window, or gravity air inlet into any building. It shall also have a minimum horizontal clearance of four feet from electric meters, gas meters, regulators, relief valves, or other equipment.
- The vent terminal shall be located not less than seven feet above grade when it is adjacent to public walkways.
- The bottom of the vent terminal shall be located at least twelve inches above grade or ground, or the normally expected snow accumulation level. The snow level may be higher on walls exposed to prevailing winds.
- Avoid areas where local experience indicates that condensate drippage may cause problems, such as the following: Above planters, patios, public walkways, or areas where condensate or vapor could create a nuisance or hazard, or where its discharge could be detrimental to the operation of regulators, relief valves, or other equipment.

GAS CONNECTION

For model IB57, the gas inlet pipe size is 1/2" NPT at the gas valve. For models IB140, IB235, and IB290, the gas inlet pipe size is 3/4" NPT at the gas valve. The gas supply line must be sized to adequately provide the input BTU/Hr rate for that model at the specified flowing pressure (see table).

The maximum inlet gas pressure must not exceed the Max value shown in the chart at right. The Min value is for the purposes of input adjustment.

The gas valve (Fig. 5) is provided with a pressure tap to measure the gas pressure downstream, which is also the manifold pressure.

Gas supply piping must have a sediment trap and a manual shutoff valve (supplied by others) installed outside of the rear cover panel, ahead of the booster heater's gas control (Fig. 5).

GAS PRESSURE SPECIFICATIONS
[*FLOWING* GAS PRESSURE — NOT STATIC]

Model Type of Gas	Inches W.C. (Water Column)		Manifold Pressure
	Incoming Line Pressure		
	Minimum	Maximum	
IB57, IB140, IB235, IB290 Natural Gas	4.5	14.0	3.2
IB57, IB140, IB235, IB290 Propane	11	13	3.2

NOTE: DO NOT use teflon tape on gas line pipe threads. For gas line pipe connections, use LOCTITE 565, Hobart part 546292, or a flexible sealant suitable for use with Natural and LP Gases.

The heater and its gas connections must be leak tested before placing the appliance in operation. Use soapy water for leak test. **DO NOT** use open flame.

The heater and its individual shutoff valve must be disconnected from the gas supply piping system during any pressure testing of that system at test pressures in excess of 1/2 psig (3.5 kPa).

The heater must be isolated from the gas supply piping system by closing its individual manual shutoff valve during any pressure testing of the gas supply piping system at test pressures equal to or less than 1/2 psig (3.5 kPa).

Dissipate test pressure from the gas supply line before re-connecting the heater and its manual shutoff valve to the gas supply line. **Caution: Failure to follow this procedure may damage the gas valve.**

Model IB57

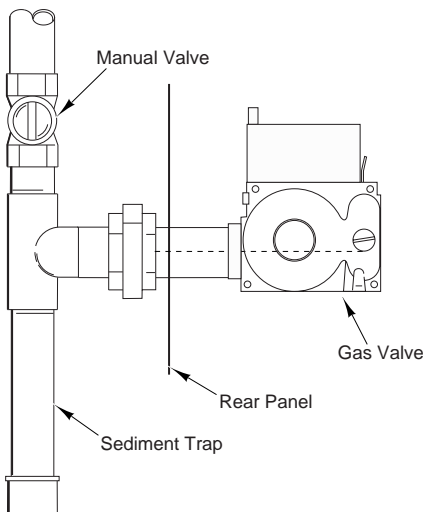

Models IB140 and IB235

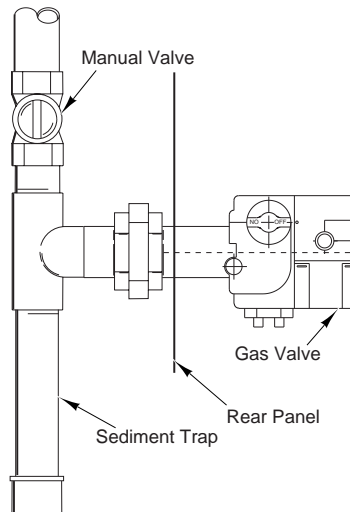

Model IB290

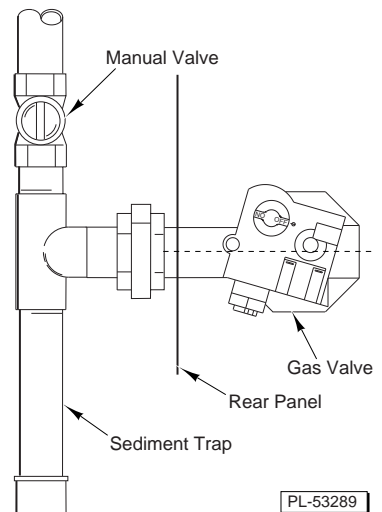

Fig. 5

WATER REQUIREMENTS

Proper water quality can improve ware washing performance by reducing spotting, lowering chemical supply costs, enhancing effectiveness of labor, and extending equipment life. Local water conditions vary from one location to another. The recommended proper water treatment for effective and efficient use of this equipment will also vary depending on the local water conditions. Ask your municipal water supplier for details about local water specifics prior to installation.

Recommended water hardness is 4 – 6 grains of hardness per gallon. Chlorides must not exceed 50 parts per million. Water hardness above 6 grains per gallon should be treated by a water conditioner (water softener or in-line treatment). Water hardness below 4 grains per gallon also requires a water treatment to reduce corrosion. Water treatment has been shown to reduce costs associated with machine cleaning, reduce deliming of the dishwasher, reduce detergent usage, and reduce corrosion of metallic surfaces in the booster water heater and dishwasher.

Sediment, silica, chlorides, or other dissolved solids may lead to a recommendation for particulate filtration or reverse osmosis treatment.

If an inspection of the booster reveals lime build-up after installation, in-line water treatment should be considered, and, if recommended, should be installed and used as directed. Contact your Hobart Service office for specific recommendations.

PLUMBING CONNECTIONS

WARNING: PLUMBING CONNECTIONS MUST COMPLY WITH APPLICABLE SANITARY, SAFETY, AND PLUMBING CODES.

The inlet and outlet water connections are $\frac{3}{4}$ inch NPT. The inlet water supplied to the booster heater must be a minimum of 110°F. Do not connect to cold water supply. Recommended flowing water pressure to the booster heater is 20 psig. Minimum is 15 psig; maximum is 25 psig. If a water pressure regulator is used to regulate the water pressure, adjust to maintain 20 psig at the dishwasher. A water pressure regulator, pressure gauge, and water shock absorber are provided by Hobart when ordered in an optional accessory Water Hammer Arrestor Kit.

Install a suitable water hammer arrester between the booster heater and dishwasher (Figs. 6 and 7).

A $\frac{3}{4}$ inch NPT drain valve is provided underneath the booster heater to allow the tank to be drained, if needed during servicing. This drain connection may be plumbed to a suitable open floor drain.

The Temperature and Pressure Relief Valve is located at the rear of the booster heater. Install a pipe from the discharge connection on the Temperature and Pressure Relief Valve to a suitable drain or catch pan with drain. The discharge connection on the Temperature and Pressure Relief Valve is $\frac{3}{4}$ inch NPT on IB57 and IB140; the connection is 1 inch NPT on IB235 and IB290. Refer to the Tag on the Temperature and Pressure Relief Valve for additional drain installation instructions.

The Temperature and Pressure Relief Valve should be manually operated at least once annually to make sure that the valve mechanism is still functional. Use care when operating the relief valve. Follow instructions on the tag located on the Temperature and Pressure Relief Valve to avoid contact with hot water discharge and to prevent water damage from operation of the valve.

Repair or alteration of the Temperature and Pressure Relief Valve in any way is prohibited by national safety standards / local codes.

If the Temperature and Pressure Relief Valve discharges occasionally or periodically, this may be due to thermal expansion in a closed water supply system. Contact the water supplier or the local plumbing inspector regarding how to correct this situation. DO NOT plug the relief valve or install a shutoff valve in the discharge drain line.

SHOWN WITH OPTIONAL WATER HAMMER ARRESTOR KIT

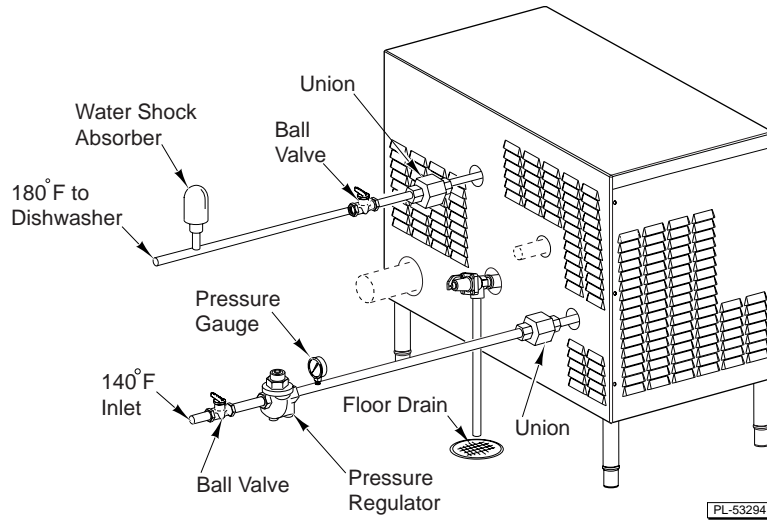
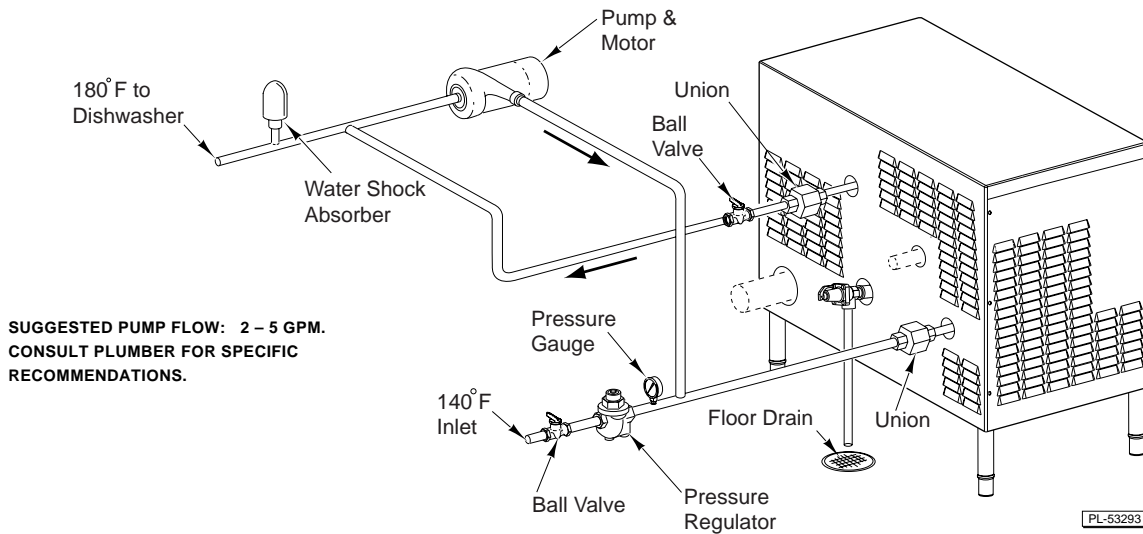

Fig. 6

The heater is equipped with a pump which circulates water inside the booster heater and maintains a uniform water temperature in the tank. Depending on the distance from the heater to the dishwasher, it may be necessary to run empty rack(s) to purge the supply line if the indicated rinse water temperature is lower than the required 180°F. For this reason, it is best to locate the booster heater as close as possible to the dishwasher. If the booster heater is located more than 10 feet from the dishwasher, an additional recirculation system (supplied by others) may be installed (Fig. 7).

SHOWN WITH OPTIONAL WATER HAMMER ARRESTOR KIT



TYPICAL PIPING FOR RECIRCULATION SYSTEM
WHEN BOOSTER HEATER IS GREATER THAN 10 FEET FROM DISHWASHER

Fig. 7

ELECTRICAL CONNECTIONS

WARNING: ELECTRICAL AND GROUNDING CONNECTIONS MUST COMPLY WITH APPLICABLE PORTIONS OF THE NATIONAL ELECTRICAL CODE AND/OR OTHER ELECTRICAL CODES.

WARNING: DISCONNECT THE ELECTRICAL POWER SUPPLY AND PLACE A TAG AT THE DISCONNECT SWITCH INDICATING THAT THE CIRCUIT IS BEING WORKED ON.

The electrical power supply requirement for the heater is 120 Volts, 60 Hz, 1 Phase. Minimum conductor ampacity and maximum protective device should be rated 15 Amperes. The electrical power for the gas booster water heater must be supplied independent of the dishwasher, whether the booster is switched on and off with a manual switch (on the Stand Alone unit only) or by the dishwasher control circuit (on the Dishwasher Activated unit only). Properly sized conduit and 14 AWG wire rated for at least 90°C must be used for wiring connections.

Polarity must be observed for the heater to operate properly: Connect the hot Black wire to [L1], the White Neutral wire to [N], and the Green wire to the Ground lug. Consult wiring diagram accessed by removing the left-front panel. Provide a separate fused circuit from the main electrical panel to the heater. Also, provide a means of disconnecting the electrical supply within sight of the heater. Keep wires away from vent.

When connecting a Dishwasher Activated gas booster water heater to the control panel on a commercial dishwasher, use the connection points labeled BSTR1 and BSTR2 on the booster. Only connect a Dishwasher Activated gas booster water heater (not a Stand Alone) to a dishwasher that has been provided with a properly labeled connection point. Refer to the instruction manual for the dishwasher (under Gas Booster Water Heater Option) to determine if this option is available and what is the proper connection point on the dishwasher.

Model IB57 uses either a 24 Volt or 120 Volt inter-connect circuit for Dishwasher Activated boosters, depending on the pilot circuit of the dishwasher model it is to be connected with. Models IB140, IB235, and IB290 use only a 120 Volt inter-connect circuit for Dishwasher Activated boosters. A Dishwasher Activated gas booster water heater should only be used with a dishwasher that is provided with the capability of connecting the gas booster water heater as an accessory.

When the gas booster water heater is connected to the vent fan control switch, the vent fan is switched on when the gas booster water heater is activated and off when the heater is off. Use connections VFC1 and VFC2 on the gas booster water heater if connecting to the vent fan control switch.

When the actual flow in the flue must be sensed to permit operation of the burner only when the vent system is operating, use connections APS1 and APS2 on the gas booster water heater to connect to an Air Pressure Switch. When making this connection, it is necessary to remove the jumper from 1TB-APS1 and 1TB-APS2. The air pressure switch is provided by others.

WARNING

ELECTRICAL AND GROUNDING CONNECTIONS MUST COMPLY WITH THE APPLICABLE PORTIONS OF THE NATIONAL ELECTRICAL CODE AND/OR OTHER LOCAL ELECTRICAL CODES.

CIRCUIT IS SENSITIVE TO VOLTAGE POLARITY. HOT SIDE OF LINE MUST BE CONNECTED TO L1 AND NEUTRAL SIDE TO N.

SERVICE ON THIS UNIT TO BE PERFORMED BY A QUALIFIED SERVICE TECHNICIAN ONLY.

FOR FIELD WIRING CONNECTIONS USE 14 AWG WIRE RATED FOR AT LEAST 90°C.

IF ANY OF THE ORIGINAL WIRE AS SUPPLIED WITH THE APPLIANCE MUST BE REPLACED, IT MUST BE REPLACED WITH THE SAME TYPE AND RATING WIRE, OR IT'S EQUIVALENT.

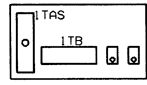
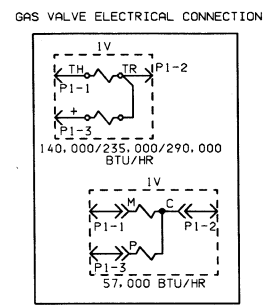
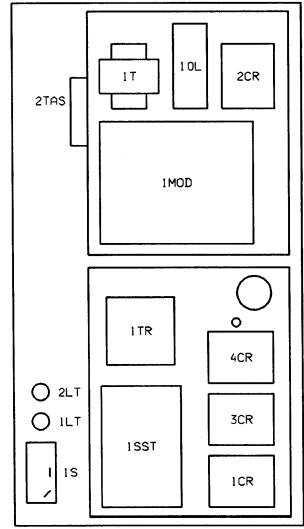
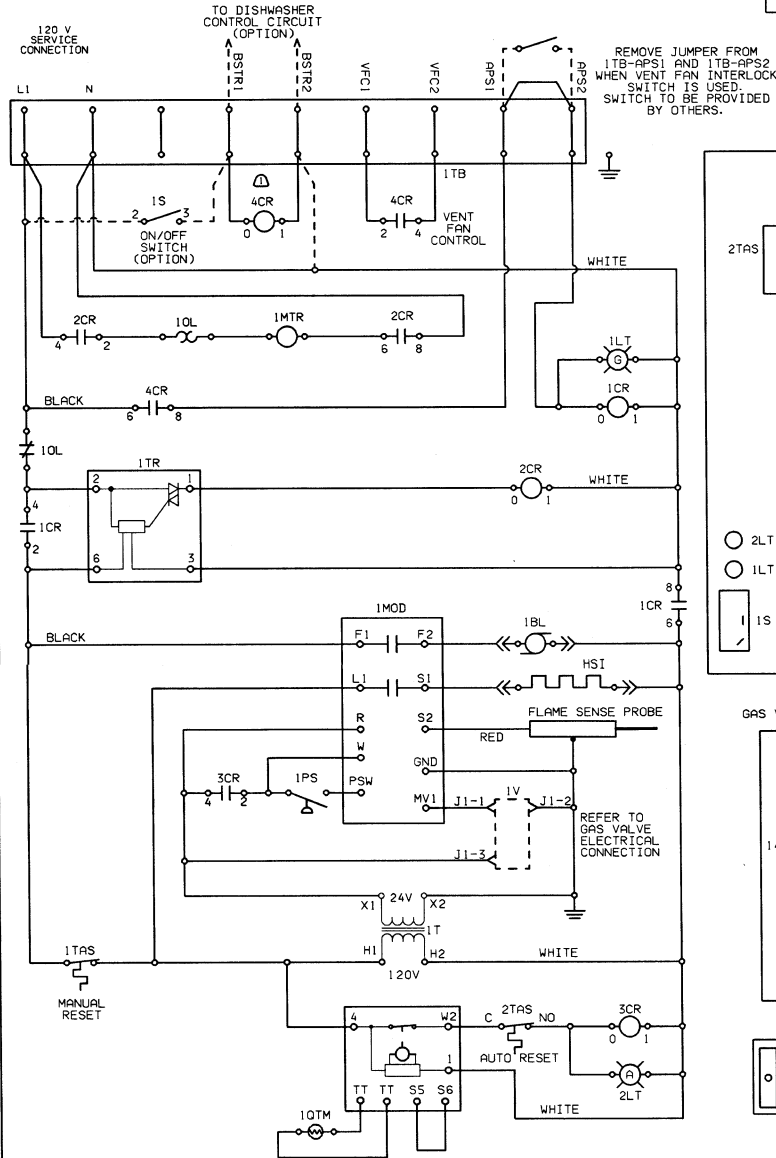

⚠ 120 VAC BSTR1 & BSTR2 CONNECTIONS FOR 57,000, 140,000, 235,000, & 290,000 BTU/HR MODELS WITH OR WITHOUT INTEGRATED CONTROLS
24 VAC BSTR1 & BSTR2 CONNECTION FOR SOME 57,000 BTU/HR MODELS WITH INTEGRATED CONTROLS

SYMBOL DEFINITIONS

- | | | |
|--|---------------------------------|-----------------------------------|
| BL BLOWER | T TRANSFORMER | TR SOLID STATE TIME DELAY RELAY |
| CONTACT - NORMALLY OPEN (N.O.) | V GAS VALVE | SST SOLID STATE THERMOSTAT |
| CONTACT - NORMALLY CLOSED (N.C.) | HSI HOT SURFACE IGNITOR | TAS MANUAL RESET MOTOR PROTECTION |
| CONNECTOR | SW SWITCH | TB TERMINAL BLOCK |
| CR CONTROL RELAY COIL | SEPARABLE CONNECTION | |
| GND GROUND | INSEPARABLE CONNECTION | |
| LT PILOT LIGHT - LETTER DENOTES COLOR | SOLID LINE STD EQUIPMENT | |
| MTR MOTOR | DASHED LINE OPTIONAL WIRING. | |
| OL MANUAL RESET MOTOR PROTECTION | TAS TEMPERATURE ACTUATED SWITCH | |
| PS PRESSURE SWITCH (SWITCH CLOSURES WHEN UNIT IS ON) | | |
| QTM THERMISTOR | | |

F-34059D
ELECTRICAL DIAGRAM
GAS BOOSTER
120/60/1

START UP PROCEDURES — FOR YOUR SAFETY READ BEFORE OPERATING

Filling the Booster Piping

Fill the booster heater with water, purging all air. Make sure water is flowing through the booster to the dishwasher's fill or final rinse before lighting the booster heater by either leaving the main power switch off on Stand Alone units or leaving the manual gas valve closed on Dishwasher Activated units.

Checking the Circulator

- Before lighting the heater, make sure the water pump is operating properly.
- With the gas valve in the off position, activate the power switch. If no power switch is present, activate the dishwasher making a demand for hot rinse water.
- The pump should start immediately. Allow the circulator to pump water through the system.

Lighting the Heater

CAUTION: Liquefied petroleum gas is heavier than air and sinks to the ground. Exercise extreme care in lighting the heater in confined areas.

WARNING: IF YOU DO NOT FOLLOW THESE INSTRUCTIONS EXACTLY, A FIRE OR EXPLOSION MAY RESULT CAUSING PROPERTY DAMAGE, PERSONAL INJURY, OR LOSS OF LIFE.

This heater **DOES NOT** have a pilot. It is equipped with a hot surface ignition device which automatically lights the burner. **DO NOT** attempt to light the burner by hand.

Before operating, smell all around the heater area for gas. Be sure to smell next to the floor because some gases are heavier than air and will settle on the floor.

WHAT TO DO IF YOU SMELL GAS

- Do not try to light any appliance.
- Do not touch any electric switch.
- Do not use any phone in your building.
- Immediately call your gas supplier from a neighbor's phone. Follow the gas supplier's instructions.
- If you cannot reach your gas supplier, call the fire department.

Use only your hand to push in, move, or turn the gas control knob or lever. Never use tools. If the knob or lever will not push in, move, or turn by hand, do not try to repair it. Call a qualified service technician. Force or attempted repair may result in a fire or explosion.

Do not use this heater if any part has been under water. Immediately call a qualified service technician to inspect the heater and replace any part of the control system and any gas control that has been under water.

Hot Surface Ignition Using the Robertshaw Gas Valve

1. **STOP!** Read the safety information.
2. Turn off all electrical power to the appliance.
3. Remove the left side panel.
4. This appliance is equipped with an ignition device which automatically lights the burners. **DO NOT** try to light the burners by hand.
5. Turn the gas control knob clockwise ↻ to the "OFF" position.
6. Wait five (5) minutes to clear out any gas. If you then smell gas, stop and follow the instructions *What To Do If You Smell Gas* (page 14). If you do not smell gas, go to the next step.
7. Turn the gas control lever counter-clockwise ↺ to the "ON" position.
8. Replace the left side panel.
9. Turn on all electric power to the appliance.
10. If the appliance will not operate, follow the instructions *To Turn Off Gas To Heater* (below) and call your service technician or gas supplier.

To Turn Off Gas To Heater

1. Turn off all the electric power to the heater if service is to be performed.
2. Remove the left side panel.
3. Push in and turn the gas control lever clockwise ↻ to the "OFF" position.
4. Replace the left side panel.

Model IB57

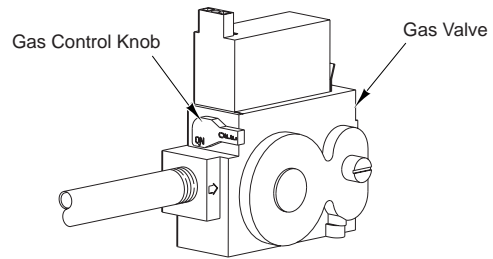

Models IB140 and IB235

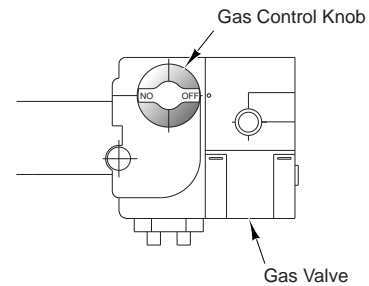

Model IB290

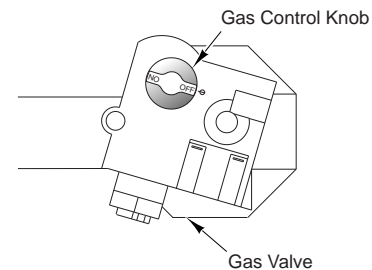

PL-53290

Fig. 8

WARNING: SHOULD OVERHEATING OCCUR OR THE GAS SUPPLY FAIL TO SHUT OFF, DO NOT TURN OFF OR DISCONNECT THE ELECTRICAL SUPPLY TO THE PUMP. SHUT OFF THE GAS SUPPLY AT THE MANUAL GAS CONTROL VALVE.

OPERATION

The booster heater is designed to deliver 180°F water, up to the gallons per minute and gallons per hour ratings specified in the table on page 4, depending on the incoming water temperature and Booster Heater model and its input BTU/Hr.

Provided the necessary power, water, gas, and vent connections are completed, a STAND ALONE unit is started by the activation of the On / Off Switch located on the front (Fig. 9). Provided the necessary power, water, gas, and vent connections are completed, the DISHWASHER ACTIVATED unit will be On when the dishwasher power switch is On. The Green indicator light is lit and the circulator pump turns on when power to the booster heater is On. The blower motor will start after about 6 seconds if the thermostat calls for heat.

Provided that the operating and safety controls including any vent switches are closed and that the thermostat is calling for heat, the Amber indicator light is lit. ⚡ The blower turns on for about 10 seconds, providing clean air in the combustion chamber. Then the gas valve opens and the hot surface ignitor heats up for four seconds. With ignition, the flame sensor will detect that the burner flame has been established. If the burner flame is not sensed within a few seconds, the circuit repeats the process from ⚡ for a total of three trial ignitions before the gas valve shuts off and requires reset.

To reset the ignition safety shutoff, momentarily turn the power switch off and then back on. If no power switch is present, turn the dishwasher off for one minute and then turn the dishwasher back on. When the water temperature exceeds the setting of the operating temperature control (thermostat board assembly), the burner will shut off until the next call for heat. The operating temperature control (thermostat board assembly) is factory set at 185°F.

On STAND ALONE units, the circulator pump will stay on as long as the On / Off Switch is on. On DISHWASHER ACTIVATED units, pump will stay on as long as the dishwasher is on. The blower is on when the thermostat is calling for heat and for 30 seconds after it is satisfied.

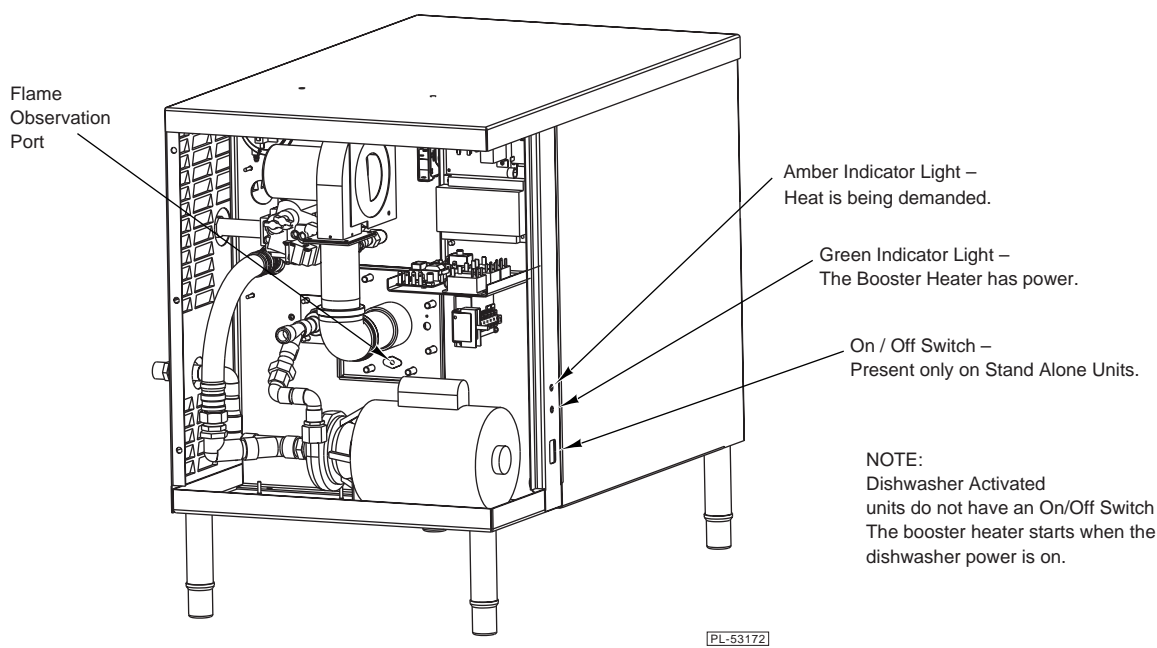

Fig. 9

MAINTENANCE

LUBRICATION

The water pump motor and the combustion air blower motor are permanently lubricated and require no other maintenance.

VENT SYSTEM

Annually check the vent system for obstruction. Check for signs of deformation in the vent pipes which will be an indication of abnormal conditions in the venting system. Refer to the instructions supplied by the vent pipe manufacturer.

CHECK BURNER FLAME

When the burner is operating properly the flame will appear to be orange with a blue tint as you look across the burner. This can be observed through the flame observation port with the left side panel removed (Fig. 9). Inspect the burner through the observation port periodically. If areas of the burner are other than described, contact your Hobart-authorized service office to have the burner inspected for proper operation.

TROUBLESHOOTING

PROBLEM	POSSIBLE CAUSE	SUGGESTED SOLUTION
On - Off switch energized. Unit does not operate.	No power to heater. Vent fan off (APS interlock).	Check circuit breaker. Check disconnect switch. Check water supply. Check manual reset switch in unit (call Service). Turn vent fan on.
Unit energized, pump and blower running but burners are NOT on.	Blocked vent. Gas off.	Remove blockage. Turn gas on.

LIST OF REPLACEMENT PARTS

When ordering parts, be sure to provide the Model Number, ML Number, and Serial Number from the data plate located on the left-front panel of the booster heater. **NOTE:** As continued product improvement is a policy of the manufacturer, part numbers may change without notification. For the latest part numbers, contact your Hobart-authorized service office.

NOTE: 57,000 BTU/Hr, 140,000 BTU/Hr & 235,000 BTU/Hr sizes apply to Natural Gas and Propane; 280,000 BTU/Hr applies to Propane only; and 290,000 BTU/Hr applies to Natural Gas only — unless specified otherwise.

Insulation - Flue

PART No.	NAME OF PART	AMT
00 749072	PLATE-PLUG (57,000 BTU/Hr)	1
00 748680	PLATE-PLUG (140,000; 235,000; 280,000; & 290,000 BTU/Hr)	1
00 749076	PLUG-COIL (INSULATION) (57,000 BTU/Hr)	1
00 748567	PLUG-COIL (INSULATION) (140,000; 235,000; 280,000 & 290,000 BTU/Hr)	1
00 749143	RETAINER-PLUG (57,000 BTU/Hr)	2
00 748682	RETAINER-PLUG (140,000; 235,000; 280,000 & 290,000 BTU/Hr)	2
00 748551	RETAINING CLIP-INSULATION	17
00 548677	INSULATION-TAPE (LINEAR FEET)	5
00 749065	CAP, EXHAUST (57,000 BTU/Hr)	1
00 748870	CAP, EXHAUST (140,000 ; 235,000; 280,000 & 290,000 BTU/Hr)	1
00 749064	INSULATION, EXHAUST (57,000 BTU/Hr)	1
00 749051	INSULATION, EXHAUST (140,000; 235,000; 280,000 & 290,000 BTU/Hr)	1

Components (Pump Side)

PART No.	NAME OF PART	AMT
00 749071	BURNER (57,000 BTU/Hr)	1
00 748560	BURNER (140,000 BTU/Hr)	1
00 748579	BURNER (235,000 BTU/Hr)	1
00 748560	BURNER (280,000 & 290,000 BTU/Hr)	1
00 476846	BLOWER (57,000 & 140,000 BTU/Hr)	1
00 748561	BLOWER (235,000 BTU/Hr)	1
00 748584	BLOWER (280,000 & 290,000 BTU/Hr)	1
00 748583 00006	RESTRICTOR PLATE (57,000 BTU/Hr Propane)	1
00 748583 00005	RESTRICTOR PLATE (140,000 BTU/Hr Propane)	1
00 748583 00004	RESTRICTOR PLATE (57,000 BTU/Hr Natural)	1
00 748583 00003	RESTRICTOR PLATE (140,000 BTU/Hr Natural)	1
00 748583 00002	RESTRICTOR PLATE (235,000 BTU/Hr Natural + Propane)	1
00 748583 00001	RESTRICTOR PLATE (290,000 BTU/Hr Natural + 280,000 BTU/Hr Propane)	1
00 749110	FITTING-ORIFICE (57,000 BTU/Hr Natural)	1
00 749110 00002	FITTING-ORIFICE (57,000 BTU/Hr Propane)	1
00 748564 00006	FITTING-ORIFICE (140,000 BTU/Hr Propane)	1
00 748564 00005	FITTING-ORIFICE (235,000 BTU/Hr Propane)	1
00 748564 00004	FITTING-ORIFICE (280,000 BTU/Hr Propane)	1
00 748564 00003	FITTING-ORIFICE (140,000 BTU/Hr Natural)	1
00 748564 00002	FITTING-ORIFICE (235,000 BTU/Hr Natural)	1
00 748564 00001	FITTING-ORIFICE (290,000 BTU/Hr Natural)	1
00 748863	VALVE-GAS BOOSTER (57,000 BTU/Hr Natural + Propane)	1
00 748563	VALVE-GAS BOOSTER (140,000 & 235,000 BTU/Hr Natural + Propane)	1
00 748588	VALVE-GAS BOOSTER (290,000 BTU/Hr Natural + 280,000 BTU/Hr Propane)	1
FP 089-27	FITTING-TUBE ⁵ / ₈ TBG x ³ / ₄ MPT STRAIGHT (140,000 & 235,000 BTU/Hr)	1
00 748591	TUBE-GAS (140,000 & 235,000 BTU/Hr)	1

Components (Pump Side) continued

PART No.	NAME OF PART	AMT
FP 047-12	FITTING-TUBE ⁵ / ₈ TBG FERRULE (140,000 & 235,000 BTU/Hr)	1
FP 012-45	FITTING-TUBE ⁵ / ₈ TBG NUT (140,000 & 235,000 BTU/Hr)	1
FP 027-22	BUSHING-PIPE ³ / ₄ TO ¹ / ₂ (280,000 & 290,000 BTU/Hr)	1
FP 077-27	ADAPTER-PIPE ¹ / ₂ FPT X ¹ / ₂ MPT (280,000 & 290,000 BTU/Hr)	1
FP 012-07	FITTING, TUBE ⁵ / ₈ TBG X ¹ / ₂ MPT 90° ELBOW (280,000 & 290,000 BTU/Hr)	1
00 748593	TUBE, GAS (280,000 & 290,000 BTU/Hr)	1
FP 047-12	FITTING, TUBE ⁵ / ₈ TBG FERRULE (280,000 & 290,000 BTU/Hr)	1
FP 012-45	FITTING, TUBE ⁵ / ₈ TBG NUT (280,000 & 290,000 BTU/Hr)	1
00 748853	INSULATION-TANK (140,000 BTU/Hr)	1
00 748549	INSULATION-TANK (235,000; 280,000 & 290,000 BTU/Hr)	1
FP 084-53	FITTING, TUBE ³ / ₈ TBG X ¹ / ₂ MPT STRAIGHT (57,000 BTU/Hr)	1
00 749111	TUBE, GAS (57,000 BTU/Hr)	1
00 748570 00002	GASKET-COIL FRONT (57,000 BTU/Hr)	1
00 748570	GASKET-COIL REAR (57,000 BTU/Hr)	1
00 748570	GASKET-COIL (140,000 BTU/Hr)	2
00 748570	GASKET-COIL (235,000; 280,000 & 290,000 BTU/Hr)	1
00 748575 00002	GASKET-COIL THREAD FRONT (57,000 BTU/Hr)	1
00 748575	GASKET-COIL THREAD REAR (57,000 BTU/Hr)	1
00 748575	GASKET-COIL THREAD (140,000 BTU/Hr)	2
00 748575	GASKET-COIL THREAD (235,000; 280,000 & 290,000 BTU/Hr)	1
00 748576 00002	PLATE-COIL SEAL FRONT (57,000 BTU/Hr)	1
00 748576	PLATE-COIL SEAL REAR (57,000 BTU/Hr)	1
00 748576	PLATE-COIL SEAL (140,000 BTU/Hr)	2
00 748576	PLATE-COIL SEAL (235,000; 280,000 & 290,000 BTU/Hr)	1
00 749100	PLUMBING (PUMP TO COIL) (57,000 BTU/Hr)	1
00 476847	PLUMBING (PUMP TO COIL) (140,000 BTU/Hr)	1
00 748574	PLUMBING (PUMP TO COIL) (235,000; 280,000 & 290,000 BTU/Hr)	1
00 749099	PLUMBING (PUMP INLET) (57,000 BTU/Hr)	1
00 476848	PLUMBING (PUMP INLET) (140,000 BTU/Hr)	1
00 748577	PLUMBING (PUMP INLET) (235,000; 280,000 & 290,000 BTU/Hr)	1
00 476395 00006	HOSE-BRAIDED (sst ³ / ₄ ") (57,000 & 140,000 BTU/Hr)	1
00 476237 00005	HOSE-BRAIDED (sst 1") (235,000; 280,000 & 290,000 BTU/Hr)	1
00 546292	SEALER	AR
00 749077	GASKET-BURNER (57,000 BTU/Hr)	1
00 748569	GASKET-BURNER (140,000; 235,000; 280,000 & 290,000 BTU/Hr)	1
00 748571 00002	IGNITOR-W/ TERMINALS	1
00 748572	ELECTRODE ASSY	1
00 748562	SWITCH-AIR (57,000 & 140,000 Natural + Propane; & 290,000 BTU/Hr Natural)	1
00 748562 00002	SWITCH-AIR (235,000 BTU/Hr Natural)	1
00 748562 00003	SWITCH-AIR (235,000 BTU/Hr & 280,000 BTU/Hr Propane)	1
00 548679	RUBBER TUBE (LINEAR FEET) (57,000 & 140,000 BTU/Hr)	5
00 548251	RUBBER TUBE (LINEAR FEET) (235,000; 280,000 & 290,000 BTU/Hr)	5
00 748550 00001	HARNES, WIRING	1
00 294700 013-1	LIGHT-INDICATOR (SEALED / AMBER)	1
00 294700 013-3	LIGHT-INDICATOR (SEALED / GREEN)	1
00 749120	VALVE- ³ / ₄ " PRESSURE TEMPERATURE RELIEF (57,000 BTU/Hr)	1
00 748685	VALVE- ³ / ₄ " PRESSURE TEMPERATURE RELIEF (140,000 BTU/Hr)	1
00 749119	VALVE- 1" PRESSURE TEMPERATURE RELIEF (235,000; 280,000 & 290,000 BTU/Hr)	1
00 088196 006-1	RELAY ELEC	1
00 112235 00023	HEATER, ELEMENT E-32 (57,000 & 140,000 BTU/Hr)	1
00 112235 00059	HEATER, ELEMENT E-54 (235,000; 280,000 & 290,000 BTU/Hr)	1

Components (Pump Side) continued

PART No.	NAME OF PART	AMT
00 294500 040-1	TRANSFORMER, 30VA, 50/60HZ	1
00 294681 028-1	THERMOSTAT, AUTO RESET	1
00 087714 046-1	RELAY (2 POLE, 120 VAC) (1CR, 2CR, 3CR)	3
00 294677 00002	CLAMP-WIRE 1/2	4
00 294677 00003	CLAMP-WIRE 3/4	1
00 784512	BOARD-IGNITOR (24VAC)	1
00 294681 027-1	THERMOSTAT-MANUAL RESET	1
00 087714 00062	RELAY-TIME DELAY	1
00 475458 00001	BOARD ASSY (TEMP CONTROL, 120-200F)	1
00 294325 013-1	BLOCK-TERMINAL	1
00 118544 00001	LUG-SOLDERLESS	2
00 476849 00001	MOTOR (235,000; 280,000 & 290,000 BTU/Hr)	1
00 476849 00002	PUMP HOUSING (235,000; 280,000 & 290,000 BTU/Hr)	1
00 476849 00003	SHAFT SEAL (235,000; 280,000 & 290,000 BTU/Hr)	1
00 476849 00004	IMPELLER (235,000; 280,000 & 290,000 BTU/Hr)	1
00 749112 00001	MOTOR (57,000 & 140,000 BTU/Hr)	1
00 749112 00002	PUMP HOUSING (57,000 & 140,000 BTU/Hr)	1
00 749112 00003	SHAFT SEAL (57,000 & 140,000 BTU/Hr)	1
00 749112 00004	IMPELLER (57,000 & 140,000 BTU/Hr)	1
00 749112 00005	FLANGE (57,000 & 140,000 BTU/Hr)	2
00 749112 00006	FLANGE GASKET (57,000 & 140,000 BTU/Hr)	2
00 749112 00007	PUMP HOUSING GASKET (57,000 & 140,000 BTU/Hr)	1
00 749112 00008	IMPELLER GASKET (57,000 & 140,000 BTU/Hr)	1
00 749112 00009	ACORN NUT (57,000 & 140,000 BTU/Hr)	1
00 749112 00010	IMPELLER SHIM (57,000 & 140,000 BTU/Hr)	1
00 749112 00011	PUMP HOUSING COVER (57,000 & 140,000 BTU/Hr)	1
00 087714 046-1	RELAY (2 POLE, 120 VAC) (4CR) (Stand Alone 57,000 BTU/Hr, non-AM14 Dishwasher Activated 57,000 BTU/Hr, and all 140,000, 235,000; 280,000 & 290,000 BTU/Hr) ..	1
00 087714 046-4	RELAY (2 POLE, 24 VAC) (4CR) (only with AM14 Dishwasher Activated Integrated Controls, 57,000 BTU/Hr)	1

SERVICE

For service problems related to this equipment, contact your local Hobart-authorized service office.

CAUTION: Label all wires prior to disconnection when servicing controls. Wiring errors can cause improper and dangerous operation. Verify proper operation after servicing.