

# PNEUMATIC PUMP

*Series 31030..*

## User and Maintenance Manual

Original text translation

## Warranty information

### TABLE OF CONTENTS

---

1. INTRODUCTION
2. DESCRIPTION OF THE PUMP
3. TECHNICAL SPECIFICATIONS
4. CORRECT USE
5. DIMENSIONS
6. DECLARATION OF CONFORMITY
7. DISTRIBUTORS



## 1. INTRODUCTION AND WARNING

---

This user's and maintenance manual refers to a *series 31030 Pneumatically Driven Pump – with light alloy or sheet steel tank*, for use in mineral oil lubrication systems.

It is recommended that this manual is carefully kept in good condition and is always available to persons requiring to consult it. To request further copies, updates or clarifications with respect to this manual contact the Engineering Department at Dropsa SpA. or from our website <http://www.dropsa.com>.

The use of the pump referred to in this manual must be entrusted to qualified personnel with a knowledge of hydraulics and electrical systems; the non-observance of the information given in this manual or the improper use of the equipment by non-qualified or non-authorized personnel can put persons or the environment at risk due to the escape of fluids under pressure.

It is of extreme importance that the instructions for use are read and understood both by the operators and maintenance personnel, in cases of doubt please contact the area representative or our "Customer Service" department.

The manufacturer reserves the right to update the product and/or the user's manual without the obligation to revise previous versions. It is however, possible to contact the Engineering Department for the latest revision in use.

It is the responsibility of the installer to utilise tubing suitable for the system; the use of unsuitable tubing can generate problems with the pump, risks to persons and cause pollution.

The loosening of connections can cause serious safety problems and all such connections should be checked before and after installation and tightened if necessary.

Never exceed the maximum operating pressure values allowed for the pump and the components to which it is connected.

Before any maintenance or cleaning operations, close off the air supply and release the pressure from the pump and the tubing to which it is connected.

Do not subject the pump, the tubing or other parts under pressure to violent impacts; damaged tubing or connections are dangerous and should be replaced.

After prolonged periods of inactivity, ensure the tightness of all connections subjected to pressure.

It is required that personnel make use of protection devices, clothing and necessary tools, suitable to the place and employment of the pump both while in operation and during the undertaking of maintenance tasks.

The pump, and any accessories mounted on it, should be carefully checked immediately on receipt and in the event of any discrepancy or complaint the Dropsa SpA Sales Department should be contacted without delay

DROPSA S.p.A. declines to accept any responsibility for injuries to persons or damage to property in the event of the non-observance of the information presented in this manual.

Any modification to component parts of the system or the different destination of use of this system or its parts without prior written authorisation from DROPSA S.p.A. will absolve the latter from any responsibility for injury or damage to persons and/or property and will release them from all obligations arising from the guarantee.

## 2. DESCRIPTION OF THE PUMP

The pump is of robust construction, with a high strength light alloy casting body, or a sheet steel body, and a piston in lapped steel.

The pump unit is made up of a cylinder in which operates a piston with an oilproof seal; a spring returns the piston to its start position.

The pump must be provided with a three way electrical or mechanical distribution device, that is: line-cylinder-discharge.

The duration of the command impulse must not be less than 3 seconds.

The release (in the discharge position) must not be less than 10 seconds.

The useful capacity means the sum of the values of the applied valves.

The expansion of flexible tubing utilised in the system will reduce the useful capacity.

### VERSIONS AVAILABLE WITH CHARACTERISTICS

Part number	pressure		c.c./stroke		tank	syst.	ratio	min. level.	weight	dimensions
	min.	max.	useful	max	litres			electric	Kg	lxdxh (mm.)
3103010	4	7	3.5	7.5	0.8	04	8.5/1	no	1.8	110x123x253
3103011	4	7	3.5	7.5	1.5	04	8.5/1	yes	4	124x123x390
3103017	4	7	3.5	7.5	6	04	8.5/1	yes	8	327x168x335
3103049	4	7	3.5	7.5	0.8	04	8.5/1	yes	2	142x123x296
3103036	4	7	3.5	7.5	6	04	8.5/1	yes	8	327x168x335
3103038	4	7	3.5	7.5	no	04	8.5/1	no	1.6	Diam. 78x142
3103001	4	7	7.5	15	0.4	06	4/1	no	2.26	84x103x253
3103002	4	7	7.5	15	0.8	06	4/1	no	2.48	117x123x253
3103015	4	7	7.5	15	1.5	06	4/1	yes	4	124x123x390
3103018	4	7	7.5	15	6	06	4/1	yes	8	327x168x340
3103006	4	7	15	30	1.5	06	4/1	no	4	124x123x343
3103019	4	7	15	30	6	06	4/1	yes	8	327x168x340
3103029	4	7	15	30	1.5	06	4/1	yes	4	124x123x390
3103020	4	7	15	30	no	06	4/1	no	1.6	Diam. 70x175
3103030	4	7	15	30	no	06	4/1	yes	2	140x114x290
3103025	4	8	3.5	7.5	0.8	26	8.5/1	no	1.8	110x123x253
3103026	4	8	3.5	7.5	1.5	26	8.5/1	yes	4	124x123x390
3103027	4	8	3.5	7.5	6	26	8.5/1	yes	8	327x168x335
3103149	4	8	3.5	7.5	0.8	26	8.5/1	no	1.8	110x123x243

### 2.1 ACCESSORIES AND REPLACEMENT PARTS

Accessories as per specific request.

#### Replacement parts:

MODEL	3103001	3103002	3103006	3103010	3103011	3103015	3103025	3103026	3103029	3103049
Filter -load										
Filter - suction	3130062	3130137	3130137	3130137	3130137	3130137	3130137	3130137	3130137	3130137

MODEL	3103017	3103018	3103019	3103027	3103036	3103020	3103030	3103038	3103149
Filter - load	3130049	3130049	3130049	3130049	3130049				
Filter - suction	3130052	3130052	3130052	3130052	3130052	3130137	3130052		3130137

### 3. TECHNICAL SPECIFICATIONS

#### 3.1 METHODS OF COMMANDING THE PUMP

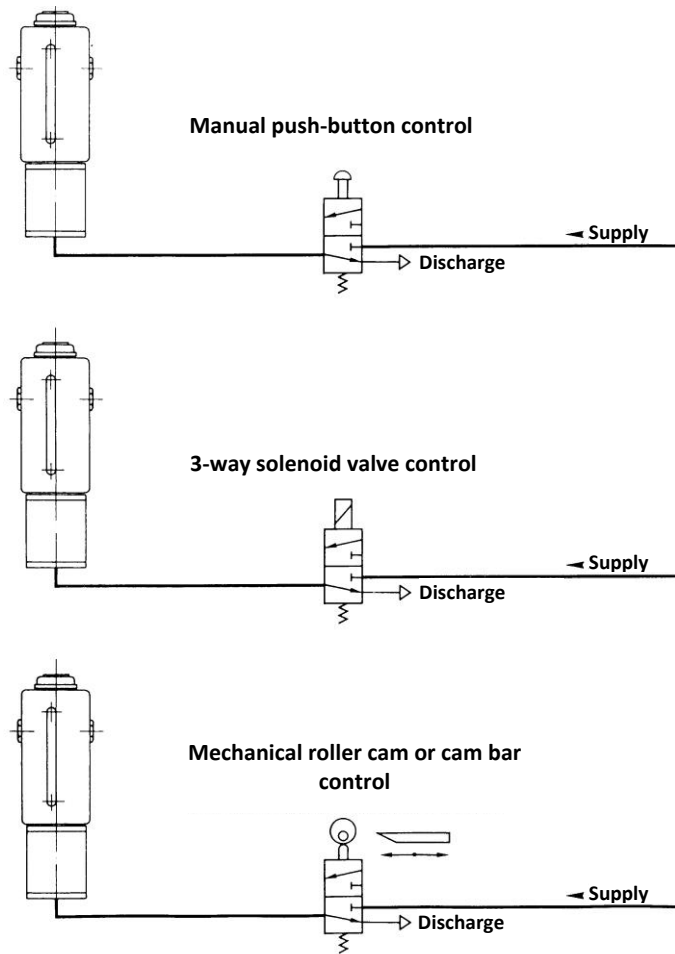

#### 3.2 OTHER DATA

Viscosity of the lubricant at working temperature	Between 15 - 1000 cSt
Working temperature	+ 5 - + 40 °C
Working humidity	90 % relative humidity.
Preservation temperature	- 20 - + 50 °C
Sound pressure level	< 70 dB(A)

## 4. CORRECT USE

---

### 4.1 PUTTING INTO SERVICE

- The unit may be used, opened and repaired only by specialised personnel.
- The pump **MUST NOT** be submersed in fluids or utilised in environments which are particularly aggressive or explosive/inflammable if not prepared for this purpose beforehand by the supplier.
- For correct fixing verify the distance between centres shown in the diagram in Section 2.
- Use gloves and safety glasses as required in the lubrication oil safety chart
- **DO NOT** use aggressive lubricants with NBR gaskets and seals; if in doubt consult the Engineering Department of Dropsa SpA, who will provide a chart with the details of recommended oils.
- **DO NOT** ignore dangers to health and observe all hygiene standards.
- **WARNING!** All electrical components must be grounded. This refers to both electrical components and control devices. In this regard ensure that the ground cable is correctly connected. For reasons of safety the ground cable must be approx. 100 mm longer than the phase cables. In the event of accidental detachment of the cable, the ground terminal must be the last to be removed.

#### *Action to be taken prior to start up*

- Verify the integrity of the pump;
- Fill the tank with suitable lubricant (min/max indication on the tank);
- Verify that the pump is at operating temperature and the tubing free from air bubbles;
- Check that the electrical connections have been effected correctly (CEI 64/8, IEC 364);
- Verify the correct connections of any level and pressure switches to the control panel
- The minimum level indicator is supplied, unless otherwise specified by the customer, with the contact closed for minimum level. Should the user require to use a normally open contact it will be necessary to open the tank and to invert the operating direction of the float.

### 4.2 USE

1. verify the settings on the control panel, where fitted;
2. press the start button of the machine to which the pump is connected;
3. verify the starting of the pump;
4. verify the adequate lubrication of the machine (if doubt exists as to the correct functioning consult the Engineering Department of Dropsa SpA to request test procedures).

### 4.3 TRANSPORT AND STORAGE

Transport and storage is effected in a cardboard package.

No particular precautions are required except as noted on the package itself.

Handling can be effected by one person.



**WARNING:** Lift the unit with taking account of the right way up indicated on the cardboard carton. The machine components can withstand temperatures, during storage, from -20 to +50°C; however, in order to avoid damage, starting of the machine should occur at a minimum temperature of -5°C.

#### 4.4 ASSEMBLY/DISASSEMBLY

No pump assembly operations are envisaged.

For wall mounting ensure adequate space is available (as shown in the installation diagram) to avoid abnormal postures and possible impacts; four fixing holes are provided with different characteristics depending on the version (see section 2.2) Subsequently it will be necessary, as previously described, to connect the pump to the machine hydraulically and then to connect the control panel.

During the disassembly phase ensure the tank is empty.

Disconnect the electrical and hydraulic parts.

Where the machine is to be scrapped, do not dispose of potentially polluting parts in the environment, following local regulations for their correct disposal.

At the time of the machine being scrapped it is necessary to remove and destroy the identification plate and all other relative documents.

#### 4.5 REGULATION

The only parameter which can be modified is the pressure; to modify the value increase or decrease the pressure of the command air supply.

#### 4.6 MAINTENANCE



**WARNING:** Locate the machine in conditions which facilitate easy access.  
Utilise individual protection to avoid contact with mineral oil or grease.

Having undergone rigorous testing by ourselves, the pump does not require any further maintenance. The use of lubricants free from impurities is recommended and the periodic careful cleaning of the component parts of the pump. Disassembly must be effected in the following manner:

1. Disconnect the tubing attached to the pump.
2. Remove the fixing screws and the tank and relative cover.
3. Remove the suction filter and the relative valve.
4. Unscrew the cylinder paying **particular attention** to the loading of the springs; the component parts of the pump unit can then be disassembled.
5. Remove the screws which retain the flange so releasing the complete pump unit.

In this way all component parts of the pump unit can be removed allowing the disassembly and cleaning of the release and suction valves.

All pieces should be washed in petrol and lubricated prior to reassembly.

The following should be checked periodically:

VERIFY	WORK CYCLES
The state of lubrication	100
The oil level	200
The cleanliness of the suction filter	400
That the tank is clean and the bottom free from deposits	600

The machine does not require any special tools to carry out checks or maintenance tasks, However, it is recommended that only tools suitable for the tasks and in good condition should be utilised (according to current regulation) to avoid injury to persons or damage to machine parts

## 4.7 REPAIRS

The following diagnostic table indicates the main anomalies which may be encountered, the probable causes and possible solutions.

The anomalies shown are:

- the pump fails to deliver sufficient oil or no oil at all;
- the pump fails to deliver oil at the prescribed pressure;
- failure to release line pressure (only on systems with volumetric valves).

In case of doubts and/or problems which cannot be resolved do not attempt to disassemble parts of the machine but contact the Engineering Department of DROPSA S.p.A.

INDICATION	PROBABLE CAUSE	REMEDY
<p><b>The pump does not deliver oil or does not deliver oil in the exact quantity prescribed</b></p>	<ul style="list-style-type: none"> <li>• The oil in the tank is below the minimum level</li> <li>• The suction filter is dirty or blocked</li> <li>• The pump control valve fails to discharge</li> <li>• The internal connections are loose</li> </ul>	<ul style="list-style-type: none"> <li>• Fill the tank with oil without exceeding the MAX level line</li> <li>• Open the cover of the pump, remove the suction filter and clean it</li> <li>• Check that the pump control valve is a 3-way type and that the valve regularly discharges compressed air from the pump pneumatic chamber when the air supply is cut off.</li> <li>• Remove the plate from the tank and carefully tighten all connections ensuring there are no leaks</li> </ul>
<p><b>The pump does not deliver oil at the prescribed pressure</b></p>	<ul style="list-style-type: none"> <li>• The compressed air pressure is insufficient</li> </ul>	<ul style="list-style-type: none"> <li>• Increase the compressed air pressure to reach the required oil pressure value</li> </ul>

#### 4.8 DANGERS PRESENT IN USE

The verification of conformity with the essential safety requirements and regulations of the Machine Directive is effected by means of the compilation of a check list which has been pre-prepared and is contained in the *technical file*.

The lists which are utilised are of three types:

- List of dangers (as in EN 414 referring to EN 292)
- Application of essential safety requirements (Machine Dir. 06/42)
- Electrical safety requirements (EN 60204-1)

The following is a list of dangers which have not been fully eliminated but which are considered acceptable:

- In the version of the pump without a release it is possible to encounter squirts of oil (for this reason appropriate protective clothing must be worn)
- Contact with oil -> see the requirements for the use of suitable personal protective clothing
- Use of unsuitable lubricant -> the characteristics of the fluid are shown on the pump and in the manual (**in case of doubt contact the Eng. Dept of Dropsa Spa**)
- Protection against direct and indirect contact must be provided by the user
- Given the purpose of the pump it must always be functioning; for this reason it is necessary to pay attention to the electrical connections which, in the case of a power failure, the customer's machine is restarted only by means of a reset, while the lubrication pump is able to restart

INADMISSIBLE FLUIDS	
Fluids	Danger
Lubricants with abrasive additives	High wear rate of contacted parts
Lubricants with silicone based additives	Seizure of the pump
Petrol – solvents – inflammable liquids	Fire – explosion – damage to seals
Corrosive products	Corrosion of the pump– injury to persons
Water	Oxidation of the pump
Food substances	Contamination of the substances themselves



## 5. DIMENSIONS AND DISTRIBUTORS

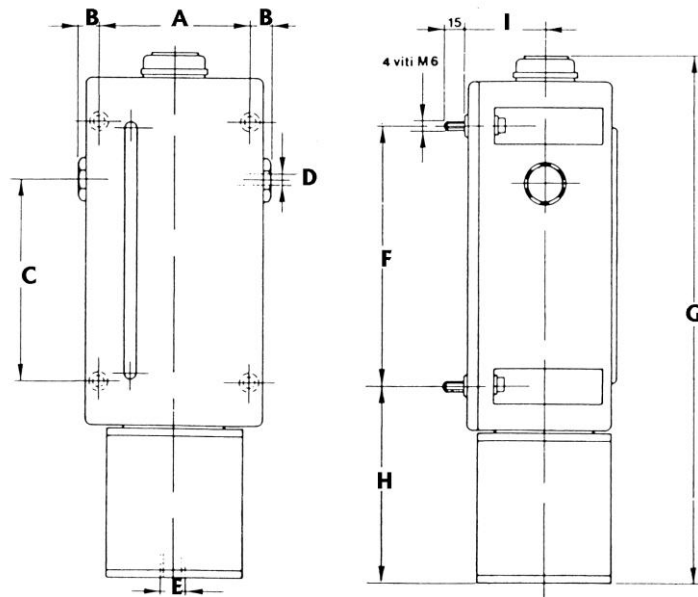

Model	A	B	C	D	E	F	G	H	I
3103001	60	12	85	M10x1	M10x1	110	253	106	44
3103002	93	12	62	M10x1	M10x1	90	253	116	54
3103006	100	12	132	M14x1,5	M14x1,5	170	343	128	54
3103010	93	12	62	M10x1	M10x1	90	253	116	54
3103011	100	12	132	M14x1,5	M14x1,5	170	390	135	54
3103015	100	12	132	M14x1,5	M14x1,5	170	390	135	54
3103025	93	12	62	M10x1	M10x1	90	253	116	54
3103026	100	12	132	M14x1,5	M14x1,5	170	390	135	54
3103029	100	12	132	M14x1,5	M14x1,5	170	390	135	54
3103049	93	12(+25 man.)	62	M10x1	M10x1	90	253	116	54
3103149	93	12	62	M10x1	M10x1	90	243	116	54

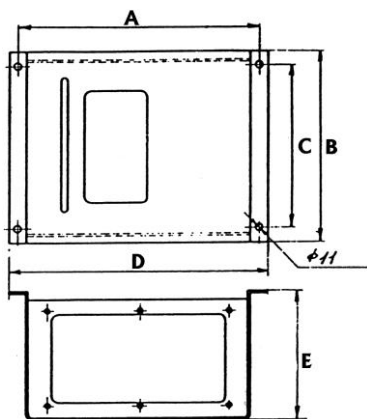

Model	A	B	C	D	E
3103017	305	335	205	327	168
3103018	305	340	205	327	168
3103019	305	340	205	327	168
3103027	305	335	205	327	168
3103036	305	335	205	327	168

## 6. DECLARATION OF CONFORMITY



**Dropsa Spa**  
Via Benedetto Croce, 1  
20090 Vimodrone (MI)  
Italy

Tel.: (+39) 02. 250.79.1  
Fax Sales: (+39) 02. 250.79.767  
E-mail: [sales@dropsa.it](mailto:sales@dropsa.it)  
Web site: <http://www.dropsa.com>



### DICHIARAZIONE **CE** DI CONFORMITÀ/DECLARATION OF COMPLIANCE WITH STANDARDS/ DECLARATION DE CONFORMITE/ KONFORMITÄTSERKLÄRUNG DES STANDARDS /DECLARACIÓN DE CONFORMIDAD/ DECLARAÇÃO DE CONFORMIDADE

La società Dropsa S.p.A., con sede legale in Milano, Via Besana,5/ Dropsa S.p.A., registered office in Milan, Via Besana,5 / Dropsa S.p.A. au Siège Social à Milan, Via Besana,5/ Dropsa S.p.A., Sitz in Milano, Via Besana 5/ La sociedad Dropsa S.p.a., con sede legal en Milán, Via Besana,5/ A Dropsa S.p.A, com sede em Milão, via Besana, nº 5

#### DICHIARA /CERTIFIES / CERTIFIE/ ZERTIFIZIERT, DASS/ DECLARA/ CERTIFICA:

che la macchina denominata/that the machine named / que la machine dénommée/ Die Maschine mit der Bezeichnung/ que la máquina denominada/ que o equipamento denominado

#### POMPE A COMANDO PNEUMATICO SERIE 31030

è conforme alle condizioni previste dalle Direttive CEE /has been constructed in conformity with the Directives Of The Council Of The European Community on the standardization of the legislations of member states/ a été construite en conformité avec les Directives Du Conseil Des Communautés Europeennes/ Entsprechend den Richtlinien des Rates Der Europäischen Union, für die Standarisierung der Legislative der Mitgliederstaaten, konstruiert wurde/ cumple con las condiciones establecidas por las directivas comunitarias/ foi construído em conformidade com as diretivas do Conselho das Comunidades Europeias:

- 2006/42 Direttiva macchine /Machinery Directive / 2006/42 Directive machines / Maschinenrichtlinien/ Maquinaria 2006/42/CEE /Directiva 2006/42 Máquinas;

Vimodrone (MI), June 2011



Technical Director:  
*Maurizio Greco*

Legal representative  
*Milena Gavazzi*

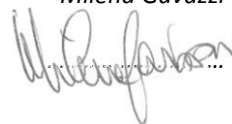

Copy of the original document

## 7. DISTRIBUTORS

---

 **Dropsa S.p.A.**  
Via B. Croce,1  
20090 Vimodrone (MI) Italy.  
Tel: (+39) 02 - 250.79.1  
Fax: (+39) 02 - 250.79.767  
E-mail: sales@dropsa.it (Export)  
E-mail: vendite@dropsa.it (National)

 **Dropsa (UK) Ltd**  
Unit 6, Egham Business Village,  
Egham, Surrey, TW20 8RB  
Tel: (+44) 01784 - 431177  
Fax: (+44) 01784 - 438598  
E-mail: salesuk@dropsa.com

 **Dropsa USA Inc.**  
6645 Burroughs Ave  
48314-2132 Sterling Hts, MI Us -USA  
Tel: (+1) 586-566-1540  
Fax: (+1) 586-566-1541  
E-mail: salesusa@dropsa.com

 **Dropsa GmbH**  
Volmerswerther Strasse 80  
40221 Dusseldorf 1, Deutschland  
Tel: (+49) 0211/39 4011  
Fax: (+49) 0211/39 4013  
E-mail: sales@dropsa.de

 **Dropsa Ame**  
23, Av.des.Morillons  
Z.I. des Doucettes 91140  
Garges Les Gonesse, France  
Tel: (+33) 01 39 93 00 33  
Fax: (+33) 01 39 86 26 36  
E-mail: salesfr@dropsa.com

 **Dropsa do Brazil Ind. E Com. Ltda**  
Rua Sobralia 175,  
Sao Paulo, Brazil  
Tel: (+55) 011-5631-0007  
Fax: (+55) 011-5631-9408  
E-mail: salesbr@dropsa.com

 **Dropsa Lubrication Systems**  
Nr 8 Dongxing Road,  
Songjiang Industrial Zone  
(Shanghai) Co., Ltd  
Tel: +86 (021) 67740275  
Fax: +86 (021) 67740205  
E-mail: china@dropsa.com

 **Dropsa Australia Pty.**  
C20/148 Old Pittwater Road  
Brookvale, NSW 2100  
Tel: +61 (02) 9938 6644  
Fax: +61 (02) 99 386 611  
E-mail: salesau@dropsa.com



Web site: <http://www.dropsa.com> - E-mail: [sales@dropsa.com](mailto:sales@dropsa.com)