



Operation Manual

H & R Healthcare
1750 Oak Street
Lakewood, NJ 08701
Phone: 800-801-5533
Fax: 732-367-6231
www.handrhealthcare.com



Congratulations and thank you for purchasing the Relief Aire Low Air Loss System. PLEASE READ THIS OPERATION MANUAL CAREFULLY BEFORE SETTING UP AND USING THE DEVICE. Please pay special attention to the warnings and other safety information. Use of genuine manufacturer components is essential for optimal performance. If you do not fully understand all the instructions, safety precautions, and warnings, do not use this device. If you have any questions or concerns, please contact H & R Healthcare at 800-801-5533.

Table of Contents

Section	Description	Page
1.0	Symbols Reference.....	4
2.0	Safety Precautions.....	4
3.0	Warnings	5
4.0	Introduction.....	5
5.0	System Components.....	5
6.0	Features.....	6
7.0	Installation.....	8
8.0	Programming Settings.....	9
9.0	Patient Transfers.....	9
10.0	Patient Transport.....	9
11.0	Deflating.....	10
12.0	Emergency CPR Deflate.....	10
13.0	Cleaning Instructions.....	10
14.0	Routine Maintenance.....	11
15.0	Troubleshooting.....	12
16.0	Returns for Service.....	13
17.0	Warranty.....	13

1.0 SYMBOLS REFERENCE



Attention! Please read accompanying documents



Double Insulated (Class II)



Functional Ground



Type BF Equipment

IPX0

Do not immerse power unit in liquid or spray liquids directly on power unit



Declaration of Conformity to Medical Device Directive



Underwriters Laboratory Agency Approval (United States/Canada)



International Electronics Approval

Indications:

This device is indicated to assist in the treatment and/or prevention of pressure ulcers as part of a holistic program of pressure ulcer management. Always consult a physician before using this device.

Contraindications:

Certain patient conditions (e.g. unstable cervical fracture) are contraindicated for use with this device. Always consult a patient's physician prior to use.

2.0 SAFETY PRECAUTIONS

Installation:

Verify mattress anchor straps are attached to bed frame securely. To ensure proper operation, inspect and verify air cells are upright and in place. Test all bed frame functions to verify

that there is no interference. Do not place anything on the power unit. Route power cord underneath bed frame and verify that it does not pose a hazard. See section 7.0 of this Manual ("Installation") for further installation instructions.

Bed Linens:

This device incorporates a waterproof cover that is moisture vapor permeable; therefore, it is recommended to limit bed linens to one sheet in order to maximize the system's performance. "Breathable" incontinent pads are recommended for use with this device.

⚠ Open Flames:

Do not expose this device to open flames, lighters, or cigarettes. This device draws room air continuously, therefore cigarette smoking is not recommended near this device. Cigarette smoke may damage internal components. Cigarettes may ignite bed linens. **CAUTION: DO NOT SMOKE CIGARETTES, PIPES, CIGARS, OR ANY OTHER RELATED PRODUCTS ON OR AROUND THIS SYSTEM. FLAMMABILITY HAZARD EXISTS.**

Cross Contamination:

This device should be decontaminated between patient installations. Refer to section 13.0 of the Manual ("Cleaning Instructions") for proper instructions. Failure to disinfect may result in cross contamination.

Bed Frame Consideration:

Verify that the patient weight, therapeutic support surface, bed rails, etc. do not exceed weight capacity of bed frame. Verify patient weight does not exceed this device's weight capacity.

3.0 WARNINGS

⚠ Entrapment:

When using side rails and/or assist devices, use a mattress thick enough and wide enough so that the gap between the top of the mattress and the bottom of the side rails and the gap between the side of the mattress and the side rails is small enough to prevent a patient from getting his or her head or neck between the mattress and the side rail. Failure to do so could result in serious patient injury or death.

⚠ Patient Falls:

Failure to use bed rails in raised position could lead to accidental patient falls. Air mattresses have soft edges that may collapse when patients roll to that edge.

⚠ Risk of Electric Shock:

DO NOT open back cover. This device is NOT user serviceable. This device should only be serviced by an authorized H & R Healthcare service technician. Please call customer service at 800-801-5533.

⚠ Oxygen Equipment:

Explosion risk if used in the presence of flammable anesthetics.

⚠ Fuse:

Danger! Risk of fire. Replace fuses as marked: T5A/250VAC (Power Fuse) and T0.5A/250V (PCB Fuse).

⚠ Electrical:

Do not insert items into any opening of the power unit. This could short internal components, which could cause fire or electrical shock. This product is NOT AP/APG protected. REFER SERVICING TO QUALIFIED PERSONNEL ONLY.

⚠ Grounding Reliability:

Grounding reliability can only be achieved when plug is connected to an equivalent receptacle marked “Hospital Grade” or “Hospital Only”.

4.0 INTRODUCTION

The Relief Aire Low Air Loss System is a mattress replacement system designed to treat and/or prevent pressure ulcers, otherwise known as bedsores. It is designed to replace a standard mattress and fit most homecare or hospital beds. The Relief Aire Low Air Loss System consists of a power unit, a mattress replacement, and a cover. The power unit utilizes a blower to provide energy efficient air flow for patients up to 1,000 lbs. It is equipped with a Max Inflate mode that quickly inflates and firms the air cells of the mattress to allow easier patient transfers on/off the mattress and facilitate other nursing procedures. Always cancel Max Inflate when finished with procedures to receive optimal patient therapy. The Mattress replacement consists of twenty air cells over a 2” convoluted foam base. The air cells are ventilated to provide low air loss, which aids moisture management. The high quality cover is made of quilted nylon taffeta. It is both waterproof and moisture vapor permeable, which helps wick moisture away from the patient’s skin.

5.0 SYSTEMS COMPONENTS

Components Supplied in the Power Unit Package:

- 1 each – Power Unit
- 1 each – Power Cord
- 1 each – Operation Manual

Components Supplied in the Mattress Assembly Package

- 1 each – Mattress Replacement with Cover

6.0 FEATURES

Control Panel Features:

See Figure 7A on next page.

⚠ Power:

NOTE: Main power switch is located on left side panel. See “left side panel” below. Press button on control panel to power up system; the yellow ON LED will illuminate. The power is in standby mode when the STANDBY/CPR orange LED is illuminated.

Patient Weight:

Press up or down buttons to adjust setting to relative patient weight. The patient weight indication is a close approximation of the correct setting. If the mattress is too soft or firm, simply press the up or down arrows to adjust as necessary. For patient comfort, wait between set point changes for the mattress to stabilize. See section 8.0 of the Manual (“Programming Settings”).

Mode:

On bariatric model, for patients exceeding 300 lbs., press and hold Bariatric button for 10 seconds for weight range of 350 - 1000 lbs. Pressing Upright button when the bed frame head section is raised adjusts pressure to prevent patient from bottoming out. Upright mode should be turned off when bed frame is in flat position. Press Panel Lock button to lock out function buttons from unauthorized changes. Max Inflate and Power (CPR) functions are not affected by Panel Lock mode. Press

Panel Lock button and hold for 3 second to cancel Panel Lock mode.

Max Inflate:

Press button to rapidly inflate mattress to maximum pressure. Press Max Inflate button after the function is no longer needed to return to Standard or Bariatric mode. The Max Inflate function will cancel automatically after 25 minutes if unattended.

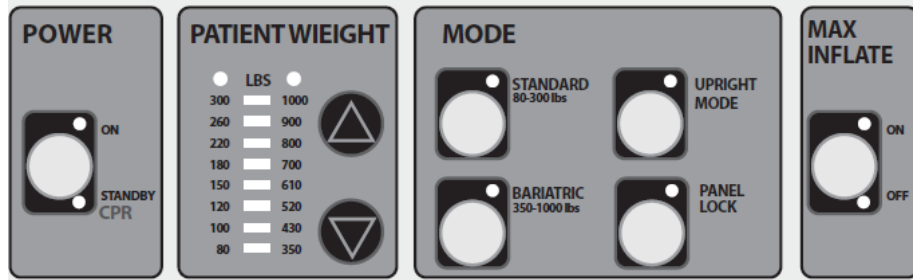

Control Panel (Figure 7a)

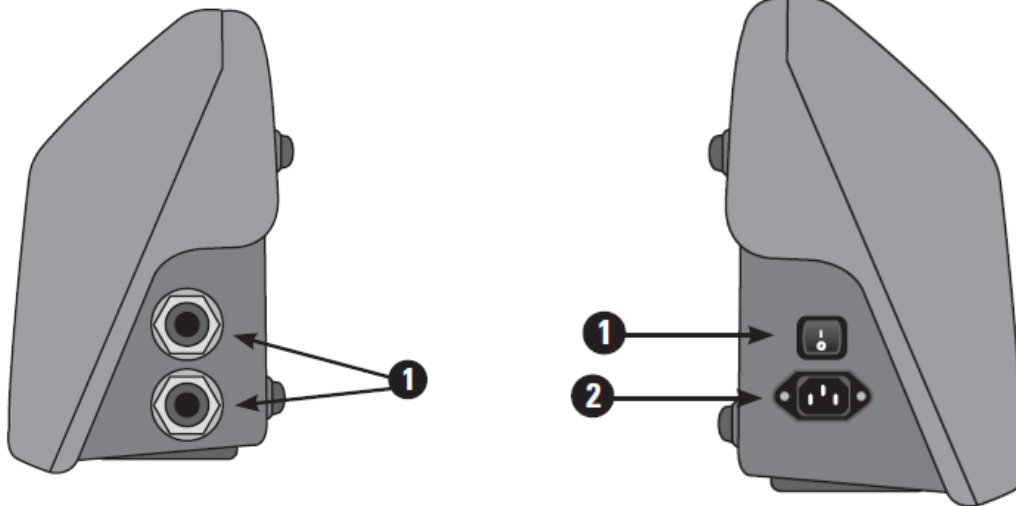

Right Side Panel Features:

Couplers (1):

Quick release female couplers are used to secure mattress air hoses to power unit.

Left Side Panel Features:

Power Switch (1):

Switch controls main power to power unit. Turning Power Switch on automatically puts power unit in Standby mode. See “Control Panel” above.

Power Receptacle (2):

Insert power cord firmly into receptacle.

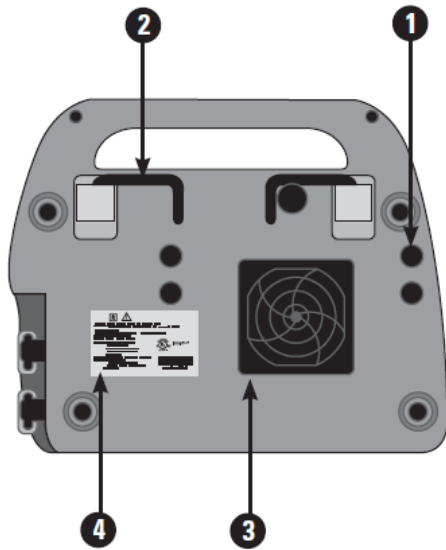

Rear Panel Features:

Fuse (1):

Fuse holders can be opened with flat head screwdriver to inspect or change fuses.

Hanging Hooks (2):

Hanging hooks are designed to fit multiple foot board widths. Hooks are spring loaded and will fold against the power unit when not in use.

Air Filter and Filter Cap (3):

No tools are necessary to remove filter cap. H & R Healthcare recommends that the filter should be inspected and cleaned or replaced with a genuine H & R Healthcare replacement part once a month to ensure optimal performance of the power unit. Filter and filter caps sold separately.

Control Number Label (4):

Label identifies control number along with agency approvals, etc.

7.0 INSTALLATION

Mattress and Power Unit Installation:

- 1: Remove existing mattress from hospital/homecare bed frame and store.
- 2: Place the Relief Aire Low Air Loss mattress replacement on the bed frame with the hose end at the foot section of the bed frame. Secure mattress replacement to each side of the bed frame using mattress anchor straps with clips. Anchor straps should be attached to the bed frame in a fashion that will not hinder the bed frame articulating up and down. Attached anchor straps should be tucked under mattress replacement to avoid any complications. **NOTE:** Before proceeding, test all bed functions to verify no restrictions or interference and ensure air cells are not twisted or out of place.
- 3: Using the integrated hanging hooks, securely hang the power unit on the bed end at the foot end or place on a smooth flat surface.
- 4: Connect the air hoses from the mattress replacement on the power unit.
- 5: Plug the power unit into a wall outlet. Refer to section 3.0 of the Manual (“Warnings”) for proper instructions. Be sure the power cord is safely away from possible hazards (e.g. foot traffic, bed tables, lifters, etc.).
- 6: Turn on the power switch on the side panel of the power unit. The system will be in Standby/CPR

mode. Press the Power button on the control panel. The power unit will begin to inflate the support surface. Max Inflate function may be used to rapidly inflate the support surface prior to use by the patient. See section 6.0 of the Manual (“Features”).

8.0 PROGRAMMING SETTINGS

- 1: After full inflation, for bariatric unit for patients exceeding 300 lbs., first press and hold Bariatric button for 10 seconds. For all models, adjust the support surface pressure using the Patient Weight buttons on the Control Panel to the appropriate weight setting. Center patient on mattress replacement to avoid accidental falls etc.
- 2: It may be necessary to alter weight setting to get optimal comfort setting for patients. If patient feels that the bed is too firm/soft, lower or increase weight setting one increment at a time and wait for stabilization before evaluating. Please note: if patient is in hospital bed in the head up or articulated position, use upright mode to prevent patient from bottoming out. See section 6.0 of this Manual (“Features”).
- 3: Caregivers should always perform a “hand check” to ensure patients are not bottoming out. A “hand check” should be performed when the patient is on the support surface by placing a hand below the air cells beneath the pelvic area of the patient. Ensure that there is an adequate amount of air supporting the

patient so they are not bottoming out.

- 4: **⚠ WARNING:** When using side rails and/or assist devices, use a mattress thick enough and wide enough so that the gap between the top of the mattress and the bottom of the side rails and the gap between the side of the mattress and the side rails is small enough to prevent a patient from getting his or her head or neck between the mattress and the side rail. Failure to do so could result in injury or death.

9.0 PATIENT TRANSFERS

Always secure bed or gurney before patient transfer. If available, engage locks on the bed casters before transferring patient. Transfers are much easier when the Relief Aire Low Air Loss power unit is in Max Inflate mode or fully deflated.

⚠ CAUTION:
Always cancel Max Inflate mode to restore optimal patient therapy. Caregivers should perform a “hand Check” as described in section 8.3 (“Programming Settings”) above.

10.0 PATIENT TRANSPORT

In the event of a patient transport, the Relief Aire Low Air Loss mattress has a safety foam base to support the patient for a short period of time. Turn off power unit and disconnect plug from wall outlet. When transport is complete, plug power cord back into a properly grounded wall outlet. See section 3.0 of this Manual (“Warnings”). It is not necessary to remove patient from

support surface before re-inflation. Refer to Section 8.0 of this Manual (“Programming Settings”).

11.0 DEFLATING

Press Power button on Control Panel to shift to Standby/CPR mode. LED will illuminate to indicate power unit is in Standby/CPR mode. Press side panel Power Switch to OFF position. Unplug power cord from wall outlet. Disconnect air hoses from side panel of power unit. Begin rolling up mattress replacement at head section forcing air out of system. Continue this process until the majority of air is removed from mattress replacement and the mattress rolls up easily. Connect the large strap buckles located on the bottom side of the mattress replacement. Place deflated mattress replacement and power unit in optional carry bag or plastic bag for transport and storage.

12.0 EMERGENCY CPR DEFLATE

In the event of an emergency, press the Power button on the Control Panel to shift the system to Standby/CPR mode. LED will illuminate to indicate power unit is in Standby/CPR mode. This will deflate the mattress rapidly so CPR can begin. To resume therapy, press Power button On and reset patient weight and mode of operation as noted in Section 8.0 of this Manual (“Programming Settings”).

13.0 CLEANING INSTRUCTIONS

Routine Cleaning While in Use by Single Patient:

Mattress Replacement:

Routine Cleaning of the air mattress can be done at bedside by cleaning with mild detergent or soap and water followed by drying with clean dry cloth. If the air mattress cover becomes heavily soiled, follow the Laundry/Decontamination instructions below. Always ensure air mattress and cover are completely dry before allowing patient back on surface.

Power Unit:

⚠ WARNING! *Always unplug power unit before cleaning.* Power unit can be cleaned by wiping down with damp cloth using soap and water or mild neutral detergent. Never spray cleaners or liquids directly on power unit.

Laundry/Decontamination Between Patients:

Mattress Replacement:

Air mattress/covers must be thoroughly cleaned between patients to avoid cross contamination. The following instructions are a good guideline, but local infection control policies should be followed.

1. Don rubber gloves, eye protection, and waterproof gown and mask if necessary.
2. Turn power unit off and remove plug from outlet to avoid electric shock.
3. Any soilage should be removed with disposable paper towels prior to disinfection.
4. Spray entire cover and mattress replacement with EPA registered hospital grade disinfectant. Let stand for appropriate contact time according to manufacturer’s instructions.
5. Cover can be easily removed and laundered in warm water

- (113F/45C) with mild detergent. Do not use electric or tumble dryers. Do not iron.
6. With mattress air cells deflated, wipe down both sides thoroughly with medical disinfectant. Allow to air dry.
 7. Thoroughly wipe down entire mattress base and tubing. If dust or soilage has accumulated, remove using swabs moistened with detergent/disinfectant. Allow all components to air dry. If storing mattress replacement, wrap mattress in plastic and store in a cool, dry area.

Power Unit:

1.  **WARNING!** *Turn power off and unplug power unit to avoid shock hazard.*
2. Dampen clean cloth with soap and water or mild detergent. Wipe power unit.
3. Disinfect power unit with hospital grade EPA registered disinfectant. Let stand for appropriate contact time according to manufacturer’s instructions.
4. Dry using a clean dry cloth or disposable paper towels.
5. Wrap in plastic and store in a cool, dry, area.

1. To access the air filter, locate the air filter cap on the back of the power unit. Refer to Section 6.0 (“Features”) of this Manual.
2. Remove air filter cap by gently squeezing sides of cap while prying away from power unit. If unable to remove air filter cap, gently insert flat head screw driver on side edge air filter cap to assist in removing cap from power unit.
3. Remove filter from filter cap.
4. Check for excess dirt or dust. The filter should be cleaned with mild soap and water or, if necessary, replaced with a genuine H & R Healthcare replacement air filter. Spare filters are available from H & R Healthcare.
5. Thoroughly air dry before reinserting.
6. To reinsert, place the air filter snugly in the air filter cap. Snap back into place on power unit. Be sure filter cap is secure.

14.0 ROUTINE MAINTENANCE

The Relief Aire Low Air Loss is designed to require very little maintenance. H & R Healthcare recommends that the air filter should be checked once a month and cleaned of visible soil.

To clean or replace the air filter:

15.0 TROUBLESHOOTING

Problem	Inspection Procedure	Possible Solutions
1.) Power unit is working, but mattress replacement is not inflating.	1.1) Verify air is flowing smoothly through hoses and mattress manifolds. Inspect for cuts or cracks.	1.1) Hose(s) or manifolds may need to be moved to avoid kinking or obstruction. If cuts or cracks where hoses enter manifold and where each air cell connects to the manifold.
	1.2) Verify hoses are properly connected to power unit.	1.2) Attach connectors securely into place.
	1.3) Verify control panel Power is ON.	1.3) Press Power button on and LED will illuminate.
2.) Patient is "bottoming out".	2.1) Look at Patient Weight setting on power unit	2.1) Increase or decrease weight setting using Patient Weight buttons until adequate pressure setting is achieved.
	2.2) Check for mattress leaks.	2.2) Call customer service at 800-801-5533 for replacement parts.
	2.3) Check Air Filter for dirt/lint	2.3) Clean or replace Air Filter.
3.) Power unit does not operate.	3.1) Verify power cord is securely plugged into live wall outlet.	3.1) Secure plug into live wall outlet. Test a different appliance in outlet to verify outlet has power.
	3.2) Verify power cord is securely plugged into power unit.	3.2) Secure plug into power unit.
	3.3) Verify power switch on left side panel in ON position.	3.3) Turn power switch to ON position.
	3.4) Verify fuse is not blown.	3.4) A power surge may temporarily overload the circuitry. Turn unit off for several seconds. Check the fuse for damage. Re-try turning unit on with normal operating procedures.
	3.5) Power unit does not respond to possible solutions listed in 3.1 thru 3.4.	3.5) Call customer service at 800-801-5533.

16.0 RETURNS FOR SERVICE

⚠ This device is NOT user serviceable. SERVICE AND REPAIR MUST ONLY BE PERFORMED BY AN AUTHORIZED H & R HEALTHCARE TECHNICIAN OR REPRESENTATIVE. All Service issues should be referred to H & R Healthcare.

17.0 WARRANTY

H & R Healthcare warrants the Relief Aire Low Air Loss system to be free from defects in material and workmanship for a period of twelve (12) months from the date of delivery.

H & R Healthcare's sole obligation and liability under this warranty is limited to (at H & R Healthcare's option) the repair or replacement by H & R Healthcare authorized personnel of any parts or assemblies, which upon test and examination by H & R Healthcare, prove to be defective. Please call H & R Healthcare Customer Service to arrange warranty service.

This warranty does not cover normal maintenance such as cleaning, adjustment, or lubrication and updating of equipment or parts thereof. This warranty shall be void and not applicable if the equipment, including any of the parts, is modified without H & R Healthcare authorization; is attempted to be repaired by personnel not authorized by H & R Healthcare; is not maintained in accordance with the prescribed schedule; is used with accessories or parts not authorized; or inadequate packaging by owner for shipment. H &

R Healthcare makes no guarantee of clinical results.

THE WARRANTY STATED ABOVE (INCLUDING ITS LIMITATIONS) IS THE ONLY WARRANTY MADE BY H & R HEALTHCARE AND IS IN LIEU OF ALL OTHER WARRANTIES, WHETHER EXPRESSED OR IMPLIED; INCLUDING ANY WARRANTY OF MERCHANTABILITY OR FITNESS FOR A PARTICULAR PURPOSE. H & R HEALTHCARE SHALL NOT BE LIABLE FOR CONSEQUENTIAL OR INCIDENTAL DAMAGES OF ANY KIND.

Note: if you have any questions regarding the Relief Aire Low Air Loss system's warranties, please call H & R Healthcare Customer Service at 800-801-5533.