

USER MANUAL

NTW-HD0808 *Network Routing Switcher Series*

HIGH DEFINITION SERIAL ROUTER - 8x8

Miranda Technologies inc.
2323 Halpern, St-Laurent
(Quebec) Canada H4S 1S3
Tel.: (514) 333-1772
Fax: (514)333-9828

Miranda USA
1101 N. Pacific Ave, suite 204
Glendale, CA 91202
USA
Tel.: (305) 820-2990
Fax: (305) 820-2991

e-mail: techsupp@miranda.com

Technical specifications are subject to be changed without notice

Index

0.	Revision history	3
1.	General	4
1.1.	Specifications	4
1.2.	Connection drawing	5
2.	Power connection	5
3.	Connecting the NTW-HD0808 to your PC	5
3.1.	Selection of router address	5
3.2.	Pin-out of RS-232 connector	6
3.3.	Maximum cable length	6
4.	MIDI connection	6
4.1.	Several routers in one system	6
4.2.	Connecting control panels	6
4.3.	Pin-out and cable type	7
4.4.	MIDI bus structure	7
4.5.	Maximum distance between MIDI devices	7
5.	Router configuration	8
5.1.	Router address	8
5.2.	Router mode	9
5.3.	Vertical interval trigger	10
5.4.	Power up mode	11
6.	Connecting video signals to the NTW-HD0808	12
7.	Control and connection of Network systems, interface protocol	12
7.1.	Important notes regarding the Network Control Protocol	12
7.1.1.	Binary Code	12
7.1.2.	Acknowledge / Echo	12
7.1.3.	RS-422 Matrixes	12
7.1.4.	Timeout	12
7.2.	Basic principles	12
7.2.1.	Example: A single unit with no MIDI connected	12
7.2.2.	Example: Several units connected by MIDI	12
7.3.	RS232	13
7.4.	MIDI	13
7.5.	Commands	13
7.5.1.	Audio crosspoint set	13
7.5.2.	Video crosspoint set	14
7.5.3.	Crosspoint status request	14
	General Environmental Requirements for Network Electronics Equipment	16

0. Revision history

Current revision of this document is the uppermost in the table below.

Revision	Replaces	Date	Change Description
2	1	09/02/01	Corrected baudrate settings
1	0	11/12/00	Changed User settings (DIP switches)
0	-	10/10/00	Initial Revision

1. General

The NTW-HD0808 is a 8x8 high definition serial digital video router with universal wideband technology to allow simultaneous switching of digital video signals from 143Mbit/s up to 1.5Gbit/s. NTW-HD0808 has automatic cable equalizing on all inputs and re-clocking with automatic standard selection on all outputs. Vertical interval switching is provided on a video reference input with PAL/NTSC color black. The NTW-HD0808 is well suited for all demanding routing tasks in digital studio and broadcast environments. The built-in RS-232 interface allows the user to control the router via the i-Control PC software with many operational features. The control bus technology allows linking the unit with the NTW-A0808 or NTW-AD0808 to create an AFV router. One or several NTW-8-ProX-Y remote control panels can control the NTW-HD0808 as well. Another unique feature of the Network 8x8 series is the possibility to reconfigure the router via the configuration switch on the back plane to create several formats of routers:

8x8	Serial Digital Video 1 layer
4x4	Serial Digital Video 2 layer

1.1. Specifications

Data rate:	143Mbit/s – 1.5Gbit/s
VIT input:	Comp. Video 1Vpp, 300mV sync, 75 ohms
Number of inputs:	8 terminated
Equalisation:	Automatic up to 100m @ 1.5G (Belden 1694A)
Number of outputs:	8
Re-clocking:	On outputs, auto standard select
Impedance:	75 ohms
Return-loss:	> 15dB (5MHz-1.5GHz)
Signal level:	800mV ±10%
Connector:	BNC
AC power:	External power supply 100 - 260 VAC
DC power:	+5V, connector DB9 male
Dimensions:	483 x 88 x 35 mm (19", 2RU)

1.2. Connection drawing

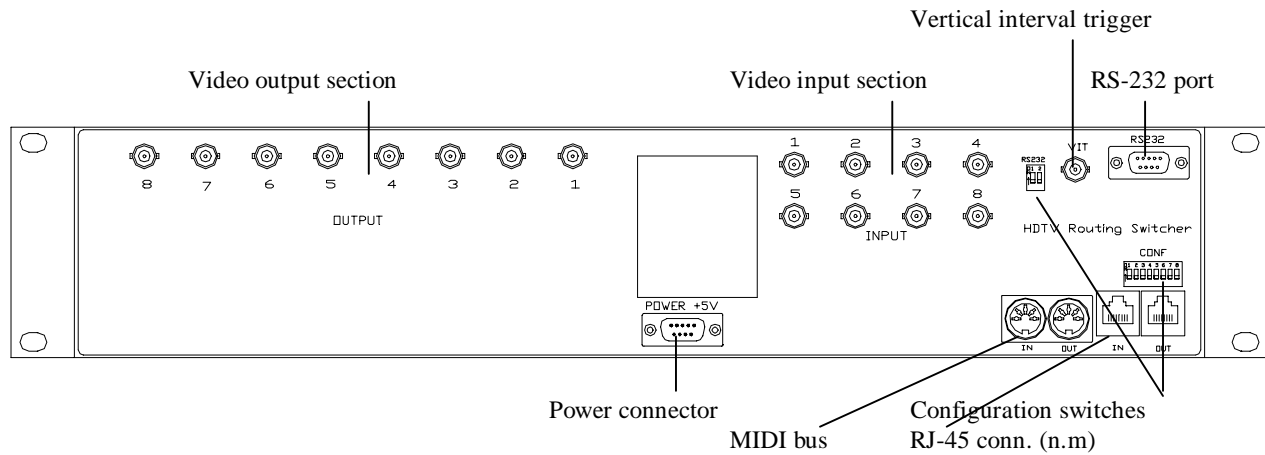

2. Power connection

Do not connect mains to the desk top power supply before connecting the power supply to the router.

Connect the DB9 female connector from the desktop power supply to the main unit. Tighten the screws to assure a proper contact. To connect mains to the desk top power supply you need a mains cord with IEC 320 connector. NTW-HD0808 uses the desk top power model **AC-10-87-30-005 (±5V / 30W)**.

If an external power supply is used the NTW-HD0808 router requires +5V DC with a minimum current of 4A. The following pin-out is used on the DB9 male power connector:

Pin 1 and 9	0V
Pin 2 and 5	+5V

3. Connecting the NTW-HD0808 to your PC

For connection to a PC with Miranda's i-Control control software the RS-232 interface is used. The RS-232 port on all Network devices uses the standard DCE pin-out, see pin-out table under 4.3. A standard modem cable can be used for connecting the router to the PC's serial port.

3.1. Selection of router address

The router address depends on the system configuration the router is going to work with. See chapter 5 for more information. All routers are delivered with default address 0. A router addressed to 0 can be controlled from the i-Control software with address 0. i-Control offers the control of up to 16 different routers or combinations of routers.

3.2. Pin-out of RS-232 connector

The DB9 female connector for the RS-232 port has the following pin-out:

Pin 2	Tx
Pin 3	Rx
Pin 5	GND

3.3. Maximum cable length

The maximum cable length for an RS-232 connection is per definition 15m. Longer distances can be installed depending on the environmental conditions of the installation site. It is up to the installer / user to secure a proper installation of the RS-232 connection.

4. MIDI connection

Via the MIDI bus system several routers and control panels can be interconnected. The standard MIDI interface is used on all Network MIDI control ports. For interconnection between the devices a standard MIDI cable with 5pin DIN connector on both ends is used. The Network MIDI bus system allows connection of up to 16 routers with different addresses on the same bus. Routers which are defined to work married, e. g. 2 routers as Audio follow Video or 3 routers as RGB (YUV) must be set on the same address. Control panels dedicated to work with a specific router must have the same address as the router. Several panels can work together with one specific router. Up to 16 single routers or combinations of routers can be controlled from one i-Control control screen. The MIDI bus system and all RS-232 ports interchange the system status.

4.1. Several routers in one system

The Network MIDI bus system allows the interconnection of up to 16 routers with different addresses in one system. A combination of routers working married counts as one address. This might for example be 1 audio router + 1 video router working as an audio follow video system or 3 video routers working as a RGB (YUV) system. The routers in such a constellation have to have the same address.

4.2. Connecting control panels

To get a control panel working with a specific router, give the control panel the same address as the router. Several panels can be addressed to the same router. The NTW-X-Y panels can control 2 layers with breakaway function. If it is necessary to control more layers with breakaway an additional panel must be used. **Panels can also be connected to a router via the RS-232 interface. Please refer to your control panel manual for installation.**

4.3. Pin-out and cable type

The pin-out of all Network MIDI ports follows the standard MIDI specification. A 1 to 1 cable with 5pin DIN connector is used. The following pin-out is used:

1 - n.c.		1 - n.c.
2 - shield #####		2 - shield
3 - n.c.		3 - n.c.
4 - data -----		4 - data data lines must
5 - data -----		5 - data be twisted pair

The standard MIDI specification recommends the use of shielded twisted pair cable types for interconnection between the units.

Alternatively the MIDI can be connected to the RJ-45 connector. The following pin-out is used:

- Pin 1 = nc
- Pin 2 = nc
- Pin 3 = nc
- Pin 4 = MIDI -
- Pin 5 = MIDI +
- Pin 6 = nc
- Pin 7 = nc
- Pin 8 = nc

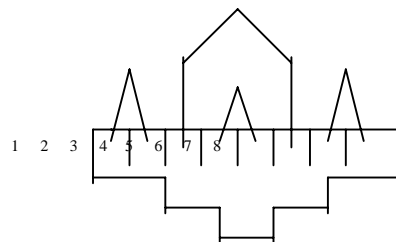

4.4. MIDI bus structure

The Network MIDI bus structure follows the standard MIDI bus definition. **The Network MIDI bus is defined as a closed chain of units. This means that the MIDI OUT of the last unit must be connected to the MIDI IN of the first unit in the MIDI chain.** To avoid problems with the control of Network units the installer/user has to assure that the bus structure is installed according to this definition. The total number of MIDI devices in a MIDI chain is limited to 50.

4.5. Maximum distance between MIDI devices

The standard MIDI definition allows a maximum cable length of 250 meters between two devices. Longer distances can be made with MIDI repeater units. To avoid grounding problems all Network MIDI ports have opto-coupled inputs.

5. Router configuration

The Dip-Switch Block, top right, (2 user switches) sets the communication channel operation. The operation can be switched according to the following pattern:

- means switch down
- * means switch up

Default setting is RS-232 operation on 9-pins DSUB.

Switch	1	2	Operation
	-	-	Not allowed
	-	*	RS-232 operation on 9-pin DSUB
	*	-	RS-422 operation on RJ-45
	*	*	Not allowed

Note that *ONLY 1* switch must be set at any time to ensure proper function.

5.1. Router address

The Dip-Switch Block, bottom right, (8 user switches) has the following switches: Switch 2 - 4 on the configuration switch set the router's address for communication with the i-Control and other units in the MIDI bus system. The i-Control control screen and the panels on the MIDI bus dedicated to operate with the router have to have the same address. If several routers are combined to form an Audio Follow Video, RGB or similar system, these routers have to have the same address.

The addresses can be switched according to the following pattern:

- means switch down
- * means switch up

Default address is 0.

Switch	2	3	4	Address
	-	-	-	0
	-	-	*	1
	-	*	-	2
	-	*	*	3
	*	-	-	4
	*	-	*	5
	*	*	-	6
	*	*	*	7

5.2. Router mode

The NTW-HD0808 router allows switching in different modes. You can choose among:

8x8	Serial Digital Video 1 layer
4x4	Serial Digital Video 2 layer

Switch 5 - 6 on the configuration switch set the router's mode. The i-Control software must be configured according to the mode chosen on the router.

The modes can be switched according to the following pattern:

- means switch down
- * means switch up

Switch	5	6	Mode	
	-	-	8x8	Serial Digital Video 1 layer
	-	*	4x4	Serial Digital Video 2 layer
	*	-	2x2	Serial Digital Video 4 layer
	*	*	2x2	Serial Digital Video 4 layer

Default mode is 8x8 Serial Digital Video 1 layer.

Serial Digital Video 1 layer

SDV Signal	Input	SDV Signal	Output
1	1	1	1
2	2	2	2
3	3	3	3
4	4	4	4
5	5	5	5
6	6	6	6
7	7	7	7
8	8	8	8

Serial Digital Video 2 layer

SDV layer 1	Input	SDV layer 1	Output
1	1	1	1
2	2	2	2
3	3	3	3
4	4	4	4

SDV layer 2	Input	SDV layer 2	Output
5	5	5	5
6	6	6	6
7	7	7	7
8	8	8	8

Serial Digital Video 4 layer

SDV layer 1	Input	SDV layer 1	Output
1	1	1	1
2	2	2	2

SDV layer 2	Input	SDV layer 2	Output
3	3	3	3
4	4	4	4

SDV layer 3	Input	SDV layer 3	Output
5	5	5	5
6	6	6	6

SDV layer 4	Input	SDV layer 4	Output
7	7	7	7
8	8	8	8

5.3. Vertical interval trigger

The NTW-HD0808 router allows VIT switching for both SDTV and HDTV.

The NTW-HD0808 accepts only standard analog black-burst/composite sync/composite video signals in 525/30, 525/29.97 or 625/25 format as the VIT reference.

In order for VIT switching of HDTV signal to work, the HDTV signal must have both the same frame-rate and Vertical sync timing (Ov incident) as the applied VIT reference.

Since the line duration is different for the HDTV signals and the VIT reference, the actual switching time is timed from the Ov incident.

Switch 1 and 7 on the configuration switch set the VIT mode. The modes can be switched according to the following pattern:

- means switch down (OFF)
- * means switch up (ON)

DIP-SW pos. 1	DIP-SW pos. 7	VIT 525/625 line	Switch timing
Don't care	ON (SDTV)	525	30uS ± 5uS after Oh line 10
Don't care	ON (SDTV)	625	30uS ± 5uS after Oh line 6
OFF (line 1)	OFF (HDTV)	525	10-15uS after Ov. *

OFF (line 1)	OFF (HDTV)	625	12-17uS after Ov. **
ON (line 7)	OFF (HDTV)	525	187-192uS after Ov. ***
ON (line 7)	OFF (HDTV)	625	225-230uS after Ov. ****

* May be used for line 1 switching for the 30Hz and 29.97Hz frame-rates of SMPTE 260M and SMPTE 274M.

** May be used for line 1 switching for the 25Hz frame-rate of SMPTE 274M and SMPTE 295M.

*** May be used for line 7 switching for the 30Hz and 29.97Hz frame-rates of SMPTE 260M and SMPTE 274M.

**** May be used for line 7 switching for the 25Hz frame-rate of SMPTE 274M.

5.4. Power up mode

Switch 8 on the configuration switch defines the power up mode. The NTW-HD0808 router provides two modes for powering up the system.

Mode 1 switches all outputs to input 1.

Mode 2 switches all outputs according to the buffered information in the routers processor system.

The power up reset can be switched according to the following pattern:

- means switch down
- * means switch up

Switch	8	Power Up Reset
	-	Mode 2
	*	Mode 1

Default is Mode 2.

6. Connecting video signals to the NTW-HD0808

The NTW-HD0808 router offers standard 75 ohms BNC connectors for video in- and outputs. All video inputs are terminated with 75 ohms.

7. Control and connection of Network systems, interface protocol

7.1. Important notes regarding the Network Control Protocol

7.1.1. Binary Code

The strings shown on the next pages are in binary coded format. Please be aware of the fact that any terminal program you may use to control a Network unit from a PC must be able to generate hexadecimal characters. ASCII characters will not be accepted.

7.1.2. Acknowledge / Echo

A matrix will reply on a crosspoint set command with an ECHO. In the case where a crosspoint is already set no ECHO will be sent. If the matrix is part of a MIDI system two types of reply will be sent. Immediately after receiving the crosspoint set command the ECHO will be sent. The matrix will then wait for the command to pass the MIDI bus system. After receiving the command from the MIDI bus system the matrix will send the command as an ACKNOWLEDGE.

7.1.3. RS-422 Matrixes

RS-422 Data Routers do not accept distribution of an input signal to several outputs. An input signal can only be routed to one single output. The Firmware of our RS-422 routers takes care of these limitations. If an input (Source) is already connected to a particular output (Destination) any connection of this input to another output will disconnect the previous connection. The router will in this case send the following message for the disconnected output: Output connected to input 128. Input 128 is an internal default for the disconnect status. Please see Network recommendations for use of RS-422 data routers for further information.

7.1.4. Timeout

The Crosspoint Status Request message has a timeout, which means that you need to wait 1 second in between request messages.

7.2. Basic principles

Any message on any level (address) which conforms to the standard arriving at either the MIDI or the RS232 port, will be re-sent on both MIDI and RS232. The only exceptions are:

- a) A matrix which recognizes its address will not re-transmit the message if the crosspoint is already set.
- b) A matrix which recognizes its address will not re-transmit the message if the output number or input number exceeds its size.
- c) A unit (matrix or panel) will not re-transmit a message arriving at the MIDI if it was re-transmitted a short while ago (typically 0.5 sec). This is done by grabbing a message storing it for the timeout period, and comparing it with new messages. After the timeout period the unit will grab a new message for compare. This is done to remove unwanted (read: unknown) messages from the MIDI ring.
- d) A message arriving at the RS232 will always be re-transmitted unless it is a matrix, and one of the cases a) or b) is fulfilled.

7.2.1. Example: A single unit with no MIDI connected

Messages sent to the RS232 of a single unit will be returned once no matter what address or input/output number the message has, unless it is a matrix which recognizes one of the conditions a) or b) above.

7.2.2. Example: Several units connected by MIDI

Messages sent to the RS232 of a single unit will be returned once no matter what address or input/output number the message has, unless it is a matrix which recognizes one of the conditions a) or b) above.

If none of the cases a) or b) is fulfilled the message will also be transmitted on the MIDI. Then if any unit on the MIDI ring recognizes any of the cases a)/b) or c), the message will stop at that point. This means that the message will only be returned once on the RS232.

However, if none of the units on the MIDI ring recognizes any of the cases a) to c), the message will return to the originator (the unit which received the message on RS232). This unit will re-transmit the message once more on both MIDI and RS232. The message is therefore returned a second time on RS232. This time one of the cases a) or c) is sure to be identified by one of the units on the MIDI ring, and the message is removed.

There is however one more special case: If several messages for unused addresses are transmitted with only little delay, one might experience that some messages are returned several times, as the store/compare/remove function in case c) can only handle a single message at the time. We therefore recommend that the user avoid sending messages to unused addresses.

7.3. RS232

The RS-232 port is used for external control of Network units. The RS-232 port allows the customer to control the equipment via Miranda's i-Control PC program or self-defined customized solutions.

Connector for the RS-232 port is a DS9 female.

Pin 2 - Tx.

Pin 3 - Rx

Pin 5 - GND

A standard DCE (Data Communication Equipment) cable can be used for connection between PC and Network equipment. The connection between the connectors is made one-to-one.

Data-rate is 19200 baud/sec.

8 data-bit, 1 stop-bit, no parity.

7.4. MIDI

The MIDI bus is used for interconnection between several Network units. Up to 50 routers and/or control panels can be linked together to form a routing system with many operational features.

The MIDI bus utilises a 5 mA current loop with opto coupled ports.

Standard connector is a 5pin DIN.

Standard MIDI cables can be used to interconnect several Network units.

Data-rate is 31.25 kbit/sec.

1 start-bit, 8 data-bit, no parity, 1 stop-bit. Logical 0 = current ON.

7.5. Commands

7.5.1. Audio crosspoint set

Only for use with Audio routers.

Command for setting of crosspoints:

1001nnnn 0kkk kkkk 0vvv vvvv

- nnnn is the matrix address from 0 up to 15.
- kkk kkkk is the output which shall be controlled.
 - kkk kkkk = output number
 - 0 = output 1
 - 127 = output 128

- vvv vvvv is the input which shall be connected to the chosen output.
 - vvv vvvv = input number

7.5.2. Video crosspoint set

Only for use with Video routers.

Command for setting of crosspoints:

1010nnnn 0kkkkkkk 0vvvvvvv

- nnnn is the matrix address from 0 up to 15.
- kkk kkkk is the output which shall be controlled.
kkk kkkk = output number
0 = output 1
127 = output 128
- vvv vvvv is the input which shall be connected to the chosen output.
vvv vvvv = input number.

7.5.3. Crosspoint status request

This command is used for status request on Audio and Video routers.

1100nnnn 0xxxxxxx

- nnnn is the matrix address from 0 up to 15.
- xxxxxxx - do not carry any information

The requested router (Audio or Video) will send its crosspoint status on MIDI OUT and RS232. The same command format as for crosspoint set is used.

General Environmental Requirements for Network Electronics Equipment

1. The equipment will meet the guaranteed performance specification under the following environmental conditions:
 - Operating room temperature range 0°C to 45°C
Except of digital video routers 0°C to 40°C
 - Operating relative humidity range up to 90% (non-condensing)

2. The equipment will operate without damage under the following environmental conditions:
 - Temperature range -10°C to 55°C
 - Relative humidity range up to 95% (non-condensing)

3. Electromagnetic compatibility conditions:

- Emissions EN 55103-1 (Directive 89/336/EEC)
- Immunity EN 55103-2 (Directive 89/336/EEC)
- Electrical safety EN 60 950

With reference to the declaration of conformity provided with the external power supply.