



# **SB72 User's Manual**

Revision 1.6  
November 13, 2007

# Table of Contents

<i>Table of Contents</i> .....	2
<i>Overview</i> .....	3
<i>Configuration</i> .....	3
<b>Hardware Configuration</b> .....	3
<b>Hardware Configuration Examples</b> .....	5
RS-232 .....	5
RS-485 .....	5
<b>Network Configuration</b> .....	6
<b>Operational Configuration</b> .....	7
Device Network Settings .....	7
Device Connection Settings .....	8
Serial Data Port Settings .....	9
<i>Connector Descriptions</i> .....	10
<i>Specifications</i> .....	12
<i>RS-232 NULL Modem Wiring</i> .....	12
<i>Network IP Address Configuration</i> .....	13
<i>Web Browsers and Proxy Servers</i> .....	13
<i>Testing with a Telnet Connection</i> .....	14

## Overview

The SB72 comes preprogrammed and ready to run on your network. Before you can begin using the device, some basic configuration is required to tell the SB72 what type of serial interface you want to use, the network address you want the SB72 to respond to, the serial data baud rate, and the TCP/IP listening port number. There are three areas of configuration: Hardware configuration, Network configuration, and Operational configuration.

## Configuration

### Hardware Configuration

Your specific configuration will depend on whether you want to use RS-232, TTL, or RS-485. There are 2 serial ports (Ports) that can be configured by jumpers on the board and through the web interface. This manual will refer to each serial port as Port 0 and Port 1. Once you have the hardware configured correctly, you will select the corresponding software options using the web interface to route serial data.

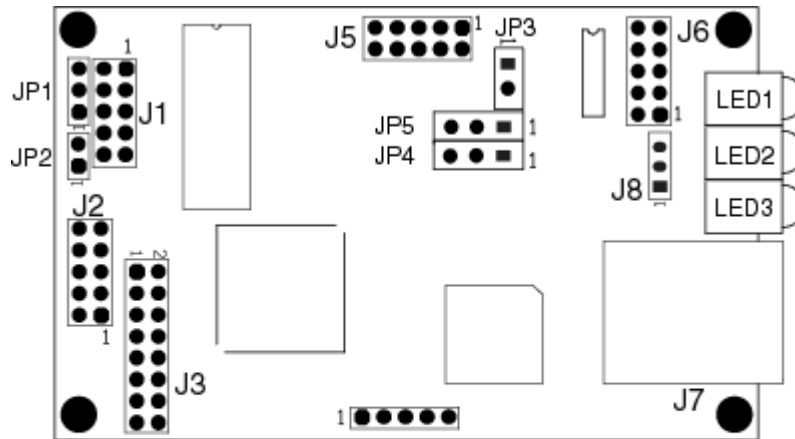

1. Connect to the desired serial interface: J6 for RS-232, or J2 for RS-485.

RS-232 Users: Connector J6 is wired to accept a standard PC type DTK 10-pin header to DB-9 cable, which will result in a DB-9 pin-out of 2 = RX, 3 = TX, and 5 = GND. If connecting to a PC, make sure to use a cross-wire cable or a null-modem adapter to swap RX and TX signals.

2. Configure the serial jumpers.

WARNING: Incorrect jumper settings may result in damage to driver components

Jumper	RS-485 J2 Port 0 Half Duplex	RS-485 J2 Port 0 Full Duplex	RS-232 J6 Port 1	RS-232 J6 Port 0	TTL J5 Port 0	TTL J5 Port 1
JP1	CLOSE 2-3	CLOSE 1-2	X	X	OPEN	X
JP2	CLOSED	CLOSED	X	OPEN	OPEN	OPEN
JP3	X	X	CLOSED	X	OPEN	X
JP4	OPEN	OPEN or 2-3	RTS 2-3	CLOSE 1-2	OPEN	X
JP5	OPEN	OPEN or 2-3	CTS 2-3	CLOSE 1-2	OPEN	X

Key: X = don't care, Open = No connection, Closed = Jumper pins

Note for RS-232 Operation: The SB72 can run 2 channels without hardware handshaking. If RTS and CTS are required, then only Port 1 can be used. RTS and CTS are available at TTL levels on the J5 connector for both channels.

3. Connect the Ethernet port to your hub or computer
4. Provide regulated 5V DC power to the board assembly. You can use the 5V power connector J8, or use the power pins on J5.
5. Verify the power and Ethernet are configured correctly by making sure the power led and link led are on.

## Hardware Configuration Examples

### RS-232

- Remove all jumpers
- Install Jumper JP3
- Optional: Install Jumpers JP4 and JP5 on pins 2-3 for RTS/CTS handshaking

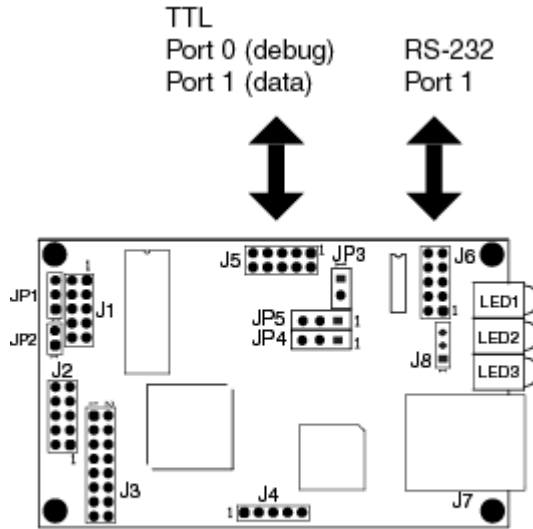

### RS-485

- Remove all jumpers
- Install Jumper JP2
- Install Jumper JP1 on pins 1-2 (full duplex) or 2-3 (half duplex)

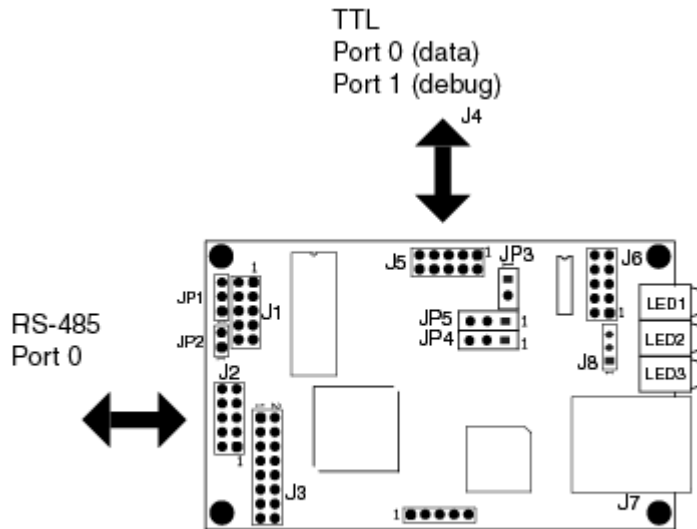

## Network Configuration

The Hardware Configuration steps above must be completed correctly before the software configuration can take place.

1. Download the IPSetup.exe utility from <http://www.netburner.com/downloads/ipsetup.exe>.
2. Run IPSetup.exe. You will see a dialog box like the one below:

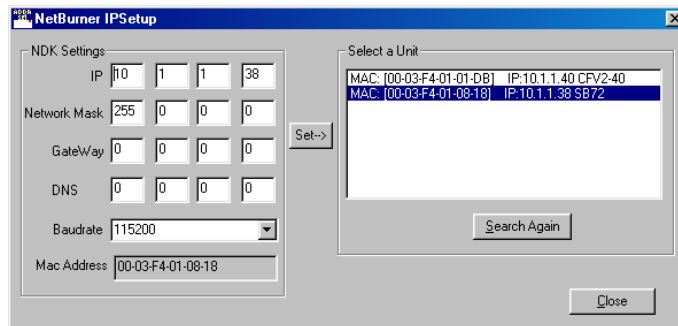

3. Select the "Find" button and locate the SB72 in the list box. If your SB72 does not appear in the list box, verify the power and link LED's are illuminated; if not, correct any cabling errors. Note that IPSetup uses a UDP broadcast protocol similar to BOOTP and will not operate through a router.

4. If your network supports DHCP:  
The assigned IP address will appear in the "select a unit" window. Write down this address.

If your network does not support DHCP:

Configure the IP Address and Mask fields. If you need help selecting values, see the Selecting an IP Address section of this manual. After you have entered the values, select the "Set" button to configure the SB72 with the new parameters.

5. Verify the network connection is working properly by executing the following command from a command prompt: "ping <ip address>".

## Operational Configuration

Once the network parameters have been configured you can use the web server interface to modify setting of the SB72. To access the web page on the SB72, open a web browser and enter the numeric IP Address in the address field.

## Device Network Settings

SB72 Device Address	Selects the IP address of the SB72 device. If DHCP is selected, the SB72 will obtain IP address information automatically, including the net mask, gateway, and DNS server. If Static is selected, you need to supply the static IP address in the edit box to the right, as well as the other device network settings
Device net mask	When using a static IP address, enter the net mask in this field
Device Gateway	When using a static IP address, enter the IP address of the Gateway in this field
DNS Server	When using a static IP address, enter the IP address of the DNS Server in this field

## Device Connection Settings

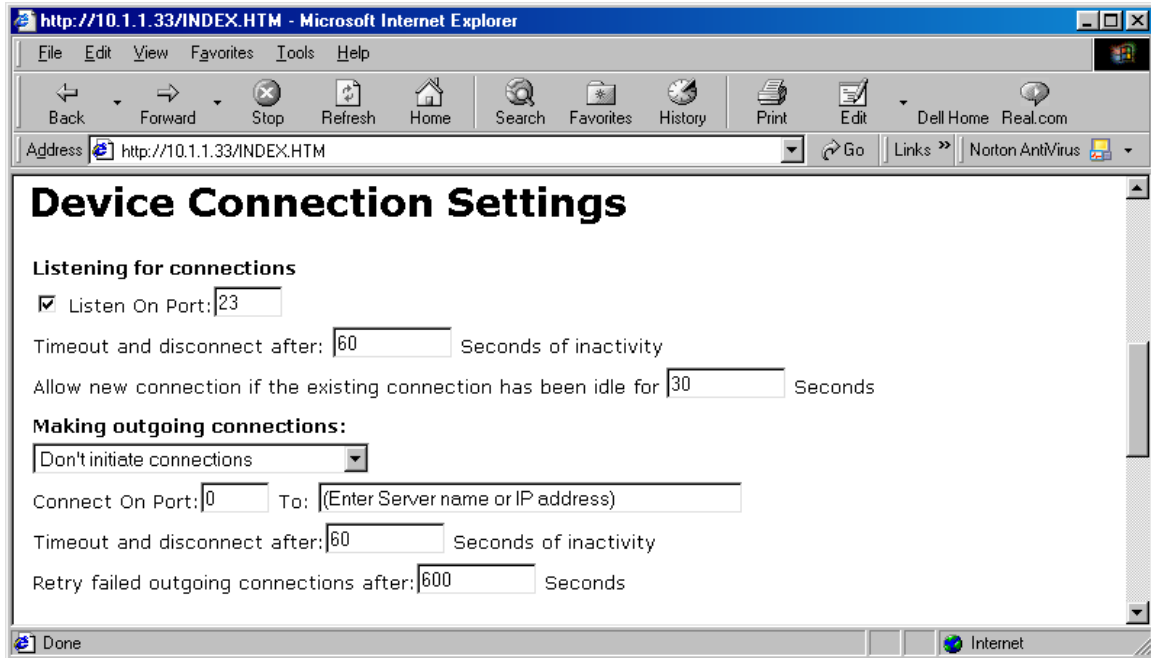

Server Listen Port:	Select the checkbox and enter the listening port number you want the TCP serial server to listen on for incoming connections.
Client Activity Timeout and Disconnect	If no activity is detected on a TCP/IP connection within this timeout period, the TCP server will drop the connection.
Client Override Timeout	If no activity is detected on a TCP/IP connection within this timeout period, the TCP server will disconnect the current TCP/IP connection and allow the new incoming connection request to connect.
Outgoing Connections	<p>If this option is enabled, the SB72 will initiate a connection to an outside destination when the selected conditions are met.</p> <p>Options are:</p> <ul style="list-style-type: none"> <li>• Don't Initiate Connections</li> <li>• Connect on Power-up</li> <li>• Connect when receiving serial data</li> </ul> <p>If this option is enabled, you must enter values for the outgoing destination port number and destination address.</p>
Outgoing Port Number	Destination port number
Outgoing Address	Either the name (e.g. www.netburner.com) or numeric IP address (e.g. 10.1.1.2) of the destination
Outgoing Timeout	Inactivity timeout for the outgoing connection



## Serial Data Port Settings

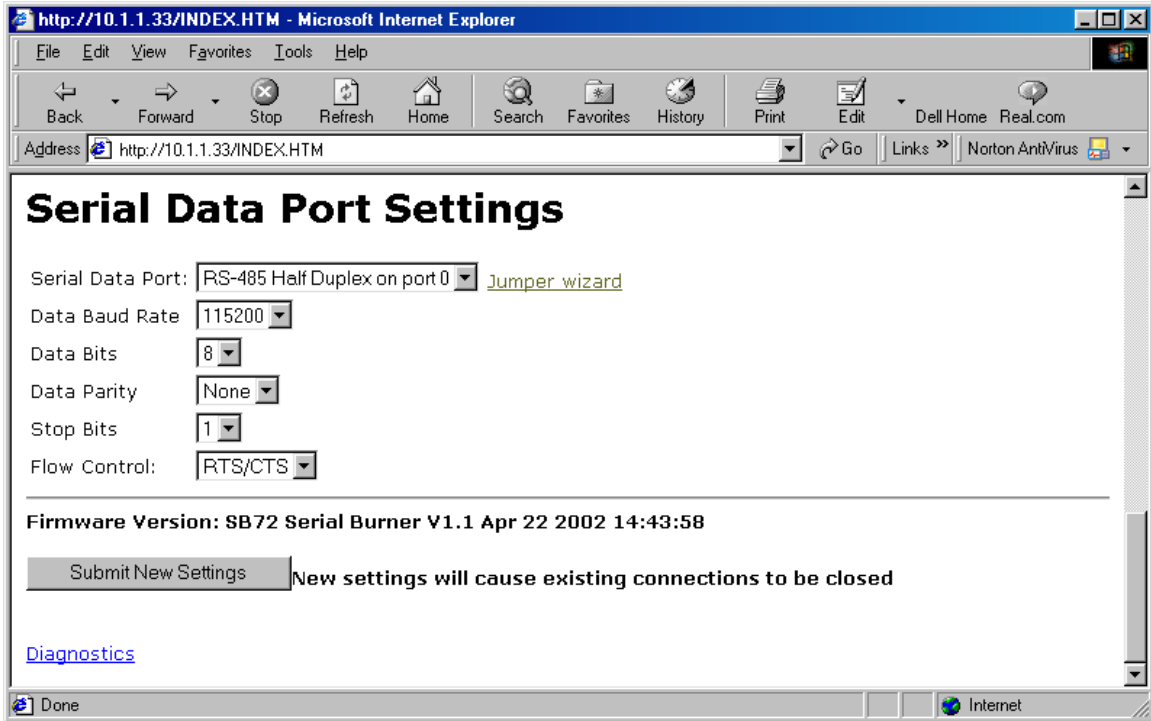

Serial Data Port	Selects the data port to be RS-232 or RS-485. Options are: <ul style="list-style-type: none"> <li>• Port 0 RS-232 or TTL</li> <li>• Port 1 RS-232 or TTL</li> <li>• Port 0 RS-485 Half Duplex</li> <li>• Port 0 RS-485 Full Duplex</li> </ul>
Data Baud Rate:	Selects the baud rate of the serial data channel
Data Bits	Select number of data bits
Data Parity	Select none, odd or even parity
Data Stop Bits	Select 1 or 2 stop bits
Flow Control	Selects serial port flow control: none, Xon/Xoff, or RTS/CTS

## Connector Descriptions

### J1 – Factory Test Connector, Dual Row 10-Pin Header

For factory use only.

### J2 – RS-485, Dual Row 10-Pin Header

The RS-485 interface supports 4-wire full duplex (FD), and 2-wire half duplex (HD). Note that jumpers JP1 – JP5 must be configured correctly to FD or HD mode.

Pin	Signal	Pin	Signal
1	FD RX-	2	GND
3	FD RX+	4	GND
5	VCC 5V	6	GND
7	FD TX+ / HD +	8	GND
9	FD TX- / HD -	10	GND

### J3 – Factory Test Connector, Dual Row 16-Pin Header

For factory use only.

### J4 – SPI Interface Connector

Single row straight header

Pin	Signal
1	GND
2	DOUT
3	CLK
4	DIN
5	/SPI_CS3

### J5 – Serial TTL Dual Row 10-Pin Header

This connector allows access to TTL level serial ports 0 and 1. Note that pin 9 is a VCC 5V input, which allows for a single connector interface with TTL serial and power to the SB72.

Pin	Signal	Pin	Signal
1	GND	2	CTS1
3	TX1	4	RX1
5	RTS1	6	RTS0
7	CTS0	8	TX0
9	VCC 5V	10	RX0

## J6 – Serial RS-232, Dual Row 10-Pin Header

This connector provides RS-232 level signals for Channel 0 and Channel 1, or RS-232 levels with hardware handshaking for Channel 1. If your application requires a null modem adapter, wiring information is provided in the "RS-232 NULL Modem Wiring" section of this manual.

Pin	Signal	Pin	Signal
1	NC	2	Short to 7
3	RX1	4	RTS1 or TX0
5	TX1	6	CTS1 or RX0
7	Short to 2	8	NC
9	GND	10	NC

## J7 – RJ-45 Ethernet Connector

Pin	Signal	Pin	Signal
1	TX+	5	-
2	TX-	6	-
3	-	7	RX+
4	-	8	RX-

## J8 – Power Connector

Single row straight 3-pin header.

### PCB REVISION 1.3 AND HIGHER

Pin	Signal
1	+5V
2	GND
3	+5V

## LEDS

LED1: Ethernet speed, 10 or 100

LED2: Link Light

LED3: Power

## Specifications

### Input Power Requirements

5 VDC @ 300mA

Operating Range: Commercial 0 – 70C

### Mechanical

PCB Dimensions: 3.25" x 2"

4 Mounting holes

## RS-232 NULL Modem Wiring

The following table and diagram show how to create a null modem cable/adaptor for RS-232 connections. A null modem cable will be required if you are connecting the SB72 to a PC using the standard NetBurner 10-pin header to DB9 ribbon cable connector.

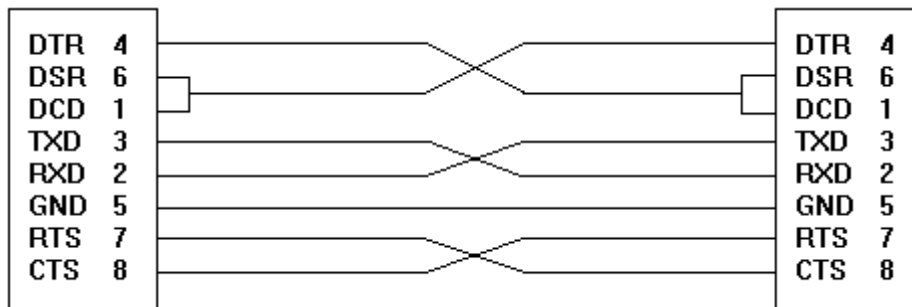

## Network IP Address Configuration

If you are part of an existing network and are not using DHCP, stop reading now and go get an IP address and network mask from your network administrator. If you follow the advice in this paragraph on an existing network without an assigned IP address, your Network Administrator will hunt you down.....

IP addresses are used to route packets from place to place on an intranet/Internet. If you are not part of an established network, and your Ethernet segment is isolated, you can choose just about any IP address you desire. The powers that be have actually set aside some addresses for isolated networks. They are documented in RFC1918. The reserved ranges are:

```
10.0.0.0      to 10.255.255.255  Class A
172.16.0.0   to 172.31.255.255  Class B
192.168.0.0  to 192.168.255.255  Class C
```

If you are doing development on an isolated network, you can use the following addresses:

- Set Your PC's Network Adapter Card IP Address to 10.1.1.10 (only change the Network Adapter Card, don't change your Dial-Up Adapter settings)
- Set the IP address of the NetBurner board to 10.1.1.11
- Set the network mask for both the PC network adapter and the NetBurner board to 255.255.255.0

## Web Browsers and Proxy Servers

If you are working on a corporate LAN that uses a proxy server for Internet web browsing, you will need to exclude the IP address of the NetBurner hardware in your web browser's proxy server settings/preferences. Otherwise, an attempt to connect to a web page on the LAN will fail because the proxy server will attempt to route the request outside the LAN. For most web browsers, this can be accomplished in the advanced settings for the proxy server configuration. Set the network mask for both to 255.255.255.0

## Testing with a Telnet Connection

One way to quickly test the functionality of your serial-to-Ethernet connection is with the Telnet program and an RS-232 serial terminal program. To run the test, configure your system as one of the two examples shown below:

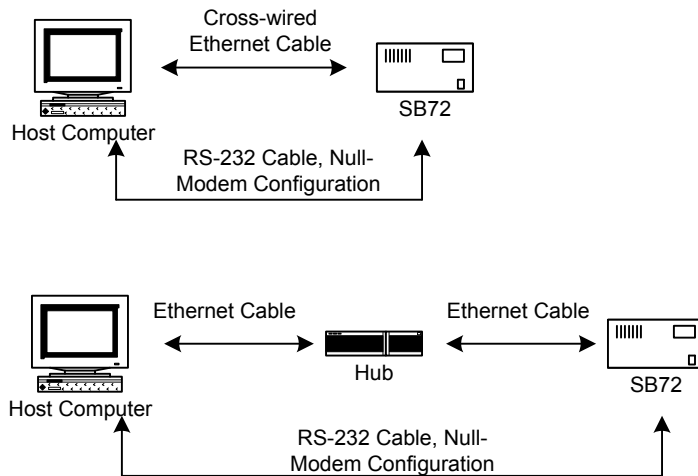

The objective of this example is to use a single host computer running telnet and a serial terminal program to send data in either direction. If you type text in the telnet window, it should appear in the serial terminal window. For a serial terminal you can use Hyper Terminal, or download MTTY from the NetBurner web site.

In the following examples an IP Address of 10.1.1.2 will be used for the SB72. Replace this number with your specific IP Address you assigned during configuration.

1. Connect the hardware in one of the above configurations
2. Open a command prompt window on the Host Computer.
3. Verify everything is connected correctly by executing "ping 10.1.1.2". You should see a valid ping response.
4. Run Telnet by typing: "telnet 10.1.1.2 9221". This assumes a default port number of 9221. You can replace this default port number with the port number you assigned during configuration.
5. Run Hyper Terminal or MTTY. Set the baud rate to the value you assigned the SB72 during configuration. The default is 115,200.
6. At this point anything you type in Telnet should appear in the serial terminal window and vice versa.

# Mouser Electronics

Authorized Distributor

Click to View Pricing, Inventory, Delivery & Lifecycle Information:

[NetBurner:](#)

[SB72-301CR](#)