

» TRACe-TR Family «



Getting Started

SD.DT.G40-2e - November 2015

Revision History

Publication Title:		TRACe-TR Family Getting Started
Doc. ID:		SD.DT.G40-2e
Rev.	Brief Description of Changes	Date of Issue
1e	Compliance with the last update of TRACe-TR User's Manual	11-2015
0e	Initial Issue	04-2015

Copyright © 2015 Kontron AG. All rights reserved. All data is for information purposes only and not guaranteed for legal purposes. Information has been carefully checked and is believed to be accurate; however, no responsibility is assumed for inaccuracies. Kontron and the Kontron logo and all other trademarks or registered trademarks are the property of their respective owners and are recognized. Specifications are subject to change without notice.

Proprietary Note

This document contains information proprietary to Kontron. It may not be copied or transmitted by any means, disclosed to others, or stored in any retrieval system or media without the prior written consent of Kontron or one of its authorized agents.

The information contained in this document is, to the best of our knowledge, entirely correct. However, Kontron cannot accept liability for any inaccuracies or the consequences thereof, or for any liability arising from the use or application of any circuit, product, or example shown in this document.

Kontron reserves the right to change, modify, or improve this document or the product described herein, as seen fit by Kontron without further notice.

Trademarks

This document may include names, company logos and trademarks, which are registered trademarks and, therefore, proprietary to their respective owners.

Environmental Protection Statement

This product has been manufactured to satisfy environmental protection requirements where possible. Many of the components used (structural parts, printed circuit boards, connectors, batteries, etc.) are capable of being recycled.

Final disposition of this product after its service life must be accomplished in accordance with applicable country, state, or local laws or regulations.



Environmental protection is a high priority with Kontron.

Kontron follows the DEEE/WEEE directive.

You are encouraged to return our products for proper disposal.

The Waste Electrical and Electronic Equipment (WEEE) Directive aims to:

- > reduce waste arising from electrical and electronic equipment (EEE)
- > make producers of EEE responsible for the environmental impact of their products, especially when they become waste
- > encourage separate collection and subsequent treatment, reuse, recovery, recycling and sound environmental disposal of EEE
- > improve the environmental performance of all those involved during the lifecycle of EEE

Conventions



Note: this notice calls attention to important features or instructions.



Caution: this notice alert you to system damage, loss of data, or risk of personal injury.



ESD: This banner indicates an Electrostatic Sensitive Device.



This symbol indicates that product must be connected to earth ground prior making any other connections to the equipment.



This symbol Indicates on the rating plate that the equipment is suitable for direct current only (24 VDC-110 VDC nominal). Identify relevant terminals



The CE marking certifies that the product complies with the essential requirements of the Directive:

- ▶ 2011/65/EC of the European Parliament and of the Council of 8 June 2011 on the restriction of the use of certain hazardous substances in electrical and electronic equipment
- ▶ 2006/95/CE of the European Parliament and of the Council of 12 December 2006 on the harmonisation of the laws of Member States relating to electrical equipment designed for use within certain voltage limits.
- ▶ 2004/108/CE of the European Parliament and of the Council of 15 December 2004 on the approximation of the laws of the Member States relating to electromagnetic compatibility

All numbers are expressed in decimal, except addresses and memory or register data, which are expressed in hexadecimal. The prefix '0x' shows a hexadecimal number, following the 'C' programming language convention.

The multipliers 'k', 'M' and 'G' have their conventional scientific and engineering meanings of $*10^3$, $*10^6$ and $*10^9$ respectively. The only exception to this is in the description of the size of memory areas, when 'K', 'M' and 'G' mean $*2^{10}$, $*2^{20}$ and $*2^{30}$ respectively.



When describing transfer rates, 'k' 'M' and 'G' mean $*10^3$, $*10^6$ and $*10^9$ *not* $*2^{10}$ $*2^{20}$ and $*2^{30}$.

In PowerPC terminology, multiple bit fields are numbered from 0 to n, where 0 is the MSB and n is the LSB. PCI and CompactPCI terminology follows the more familiar convention that bit 0 is the LSB and n is the MSB.

Signal names ending with an asterisk (*) or a hash (#) denote active low signals; all other signals are active high.

Signal names follow the PICMG 2.0 R3.0 CompactPCI Specification and the PCI Local Bus 2.3 Specification.

For Your Safety

Your new Kontron product was developed and tested carefully to provide all features necessary to ensure its compliance with electrical safety requirements. It was also designed for a long fault-free life. However, the life expectancy of your product can be drastically reduced by improper treatment during unpacking and installation. Therefore, in the interest of your own safety and of the correct operation of your new Kontron product, you are requested to conform with the following guidelines.

High Voltage Safety Instructions

As a precaution, in case of danger, the power connector is the product's main disconnect device and must be easily accessible.

**Warning!**

All operations on this device must be carried out by sufficiently skilled personnel only.

**Caution, Electric Shock!**

Before installing a not hot-swappable Kontron product into a system always ensure that your mains power is switched off. This applies also to the installation of piggybacks. Serious electrical shock hazards can exist during all installation, repair and maintenance operations with this product. Therefore, always unplug the power cable and any other cables which provide external voltages before performing work.

Earth ground connection to vehicle's chassis or a central grounding point shall remain connected. The earth ground cable shall be the last disconnected or the first connected during operations of cabling.

Special Handling and Unpacking Instructions

**ESD Sensitive Device!**

Electronic boards and their components are sensitive to static electricity. Therefore, care must be taken during all handling operations and inspections of this product, in order to ensure product integrity at all times

Do not handle this product out of its protective enclosure while it is not used for operational purposes unless it is otherwise protected.

Whenever possible, unpack or pack this product only at EOS/ESD safe work stations. Where a safe work station is not guaranteed, it is important for the user to be electrically discharged before touching the product with his/her hands or tools. This is most easily done by touching a metal part of your system housing.

It is particularly important to observe standard anti-static precautions when changing piggybacks, ROM devices, jumper settings etc. If the product contains batteries for RTC or memory backup, ensure that the board is not placed on conductive surfaces, including anti-static plastics or sponges. They can cause short circuits and damage the batteries or conductive circuits on the board.

General Instructions on Usage

In order to maintain Kontron's product warranty, this product must not be altered or modified in any way. Changes or modifications to the device, which are not explicitly approved by Kontron and described in this manual or received from Kontron's Technical Support as a special handling instruction, will void your warranty.

This device should only be installed in or connected to systems that fulfill all necessary technical and specific environmental requirements. This applies also to the operational temperature range of the specific system version, which must not be exceeded.

In performing all necessary installation and application operations, please follow only the instructions supplied by the present manual.

Keep all the original packaging material for future storage or warranty shipments. If it is necessary to store or ship the product, please re-pack it as nearly as possible in the manner in which it was delivered.

Special care is necessary when handling or unpacking the product. Please consult the special handling and unpacking instruction.

Only TRACE-B304-TR variant of the TRACE-x304 TR family is supposed to be opened by qualified integrators for customization, following Kontron recommendations described in the specific "TRACe B304-TR Customization Guide - SD.DT.G46". Then, any modifications performed on the unit render the guarantee void.

Table Of Contents

Chapter 1 - Introduction	1
1.1 Manual Overview	2
1.1.1 Objective	2
1.1.2 Audience	2
1.1.3 Scope	2
1.1.4 Structure	2
Chapter 2 - Getting Started with TRACe-TR Family	3
2.1 Receipt of the Equipment	3
2.1.1 Checking the Packages	3
2.1.2 Unpacking	3
2.2 System Identification	4
2.3 System Specification	5
2.4 Operational Side: I/O Connectors Pinout	7
2.4.1 DC IN: External PSU M12 Connector, Male, 4 Pin, A coded.	7
2.4.2 LAN B, LAN C: Ethernet M12 Connectors, Female, 8 Pin, X coded.	9
2.4.3 COM B, COM C: Serial SUBD9 Connectors, Male, 9 Pin.	10
2.4.4 GPIO: SUBD25 Connector, Female, 25 Pin.	11
2.4.5 Audio: SUBD9 Connector, Female, 9 Pin.	12
2.5 Maintenance Side: I/Os Connector Pinout	13
2.5.1 COM A: RJ-12 Connector	13
2.5.2 LAN A Gigabit Ethernet Port	14
2.5.3 USB B: USB 3.0 Connector	15
2.5.4 USB A: USB 2.0 Connector	16
2.5.5 SIM CARDS: SIM Connectors	17
2.5.6 DP: DisplayPort Connector	18
2.6 Specific I/Os	19
2.6.1 USB C: M12 Connector Female, 5 Pin, A coded.	19
2.6.2 X1, X2: SUBD9 Connectors, 9 Pin (X1: Male, X2: Female)	20
2.6.3 A4, A5, A6 Connectors ("OPT" Plate on Operational Side)	21
2.6.4 A1, A2, A3 Connectors (Maintenance Side)	21
2.7 Optional Cables Kits	22
2.7.1 TRACE-KIT-CAB-EVAL	22
2.7.2 TRACE-KITSATA-1	22
2.7.3 TRACE-STARTERKIT-1	22
2.8 Plug and Play with TRACe-TR Family	23
2.8.1 Plug	23
2.8.2 Play	25
2.9 Device Management	28
2.9.1 Power status LED	28
2.9.2 Status and User LEDs	28

2.9.2.1	Status User LEDs	29
2.9.2.2	Ethernet status LEDs	30
2.9.3	Computer Reset	31
2.10	Health Management Unit Use Cases	32
2.10.1	In-Band Health Management	33
2.10.2	Out-Of-Band Health Management	34
2.11	Linux	35
2.11.1	BSS Overview	35
2.11.2	OS Release	35
2.11.3	Live CD Contents	35
2.11.4	BSS Installation on HDD	35
2.11.5	Network Configuration	42
2.12	Windows	43
2.12.1	Windows 7 Installation	43
2.12.2	Driver and BSP Installation	43
2.12.3	KEAPI	43
2.12.4	BSP Tool	44
2.12.5	Other Windows versions	44
Appendix A	- Associated Documentation	46
Appendix B	- List of Abbreviations	47

List Of Figures

Figure 1: TRACe-TR Family Overview	1
Figure 2: Identification Label Location	4
Figure 3: TRACe B304-TR, TRACe B314-TR, TRACe G304-TR, TRACe M304-TR Dimensions	6
Figure 4: TRACe V304-TR Dimensions	6
Figure 5: DC IN Connector	7
Figure 6: Ignition Implementation	8
Figure 7: LAN B, LAN C Connectors	9
Figure 8: COM B, COM C Connectors	10
Figure 9: GPIO Connector	11
Figure 10: Audio Connector	12
Figure 11: COM A Connector	13
Figure 12: LAN A Gigabit Ethernet Connector	14
Figure 13: USB 3.0 Connector	15
Figure 14: USB 2.0 Connector	16
Figure 15: SIM Connectors	17
Figure 16: DisplayPort Connector	18
Figure 17: USB C Connector	19
Figure 18: X1, X2 Connectors	20
Figure 19: A4, A5, A6 Connectors	21
Figure 20: A1, A2, A3 Connectors	21
Figure 21: Connecting TRACe-TR Family	23
Figure 22: Power On LED	28
Figure 23: Status LEDs	28
Figure 24: Computer Reset	31
Figure 25: TRACe Block Diagram	32
Figure 26: In-Band Health Management	33
Figure 27: Out-Of-Band Health Management	34
Figure 28: Kontron EAPI Architecture	44

List Of Tables

Table 1: Technical Specifications of the TRACe-TR Family	5
Table 2: DC IN Pin Configuration	7
Table 3: LAN B, LAN C Connectors Pin Configuration	9
Table 4: COM B, COM C Connectors Pin Configuration	10
Table 5: GPIO Connector Pin Configuration	11
Table 6: Audio Connector Pin Configuration	12
Table 7: COM A Connector Pin Configuration	13
Table 8: Gigabit Ethernet Connector Pin Assignment	14
Table 9: USB 3.0 Connector Pin Assignment	15
Table 10: USB 2.0 Connector Pin Assignment	16
Table 11: SIM Connector Pin Assignment	17
Table 12: DisplayPort Connector Pin Assignment	18
Table 13: USB C Connector Pin Configuration	19
Table 14: Status User LEDs Description	29
Table 15: Ethernet LEDs Status Definition	30

Chapter 1 - Introduction

Kontron TRACe-TR Family is an EN50155 certified fanless Operational Computer designed to ensure stable operation in harsh environments. The "B" version is specifically designed to ease customization thanks to Mini-PCIe slots and multiple configuration extensions to help integrators meet application-specific requirements. The TRACe-TR Family is based on a COM Express® CPU module featuring Intel® Atom E3845 Bay Trail (quad core @ 1.91 GHz).

Kontron COMe Intel® Atom E3845 Bay Trail CPU: <http://www.kontron.com/products/computeronmodules/com-express/com-express-mini/come-mbt10/specification>

Kontron TRACe-TR Family website page: <http://www.kontron.com/products/systems-and-platforms/transportation-systems-and-platforms/trace---intelligent-transportation-computer/>



Non-contractual photographs

Figure 1: TRACe-TR Family Overview

1.1 Manual Overview

1.1.1 Objective

This guide provides general information, hardware instructions, operating instructions and functional description of the TRACe-TR Family systems. The onboard programming, onboard firmware and other software (e.g. drivers and BSPs) are described in detail in separate guides (see section Appendix A "Associated Documentation" page 46).

This hardware technical documentation reflects the most recent version of the product. Functional changes that differ from previous version of the document are identified by a vertical bar in the margin.

1.1.2 Audience

This manual is written to cover, as far as possible the range of people who will handle or use the TRACe-TR system, from unpackers/inspectors, through system managers and installation technicians to hardware and software engineers. Most chapters assume a certain amount of knowledge on the subjects of single board computer architecture, interfaces, peripherals, system, cabling, grounding and communications.

1.1.3 Scope

This manual describes all variants of the TRACe-TR Family.

1.1.4 Structure

This manual is structured in a way that will reflect the sequence of operations from receipt of the system up to getting it working. Each topic is covered in a separate chapter and each chapter begins with brief introduction that tells you what the chapter contains. In this way, you can skip any chapters that are not applicable or with which you are already familiar.

The chapters are:

- ▶ Chapter 1 - Introduction (this chapter)
- ▶ Chapter 2 - Getting Started with TRACe-TR Family
- ▶ Appendix A - Associated Documentation
- ▶ Appendix B - List of Abbreviations

Chapter 2 - Getting Started with TRACe-TR Family

2.1 Receipt of the Equipment

2.1.1 Checking the Packages

Inspecting the packing cartons and verifying their condition is the responsibility of the customer and should be carried out upon delivery.

- > Inspect the packing and check its condition:
 - ▶ no broken corners,
 - ▶ general state of the case (no rips or holes),
 - ▶ condition of the bands and the clips.
- > If you wish to report any damage in transit, you should make out a full report, and also note the damage on the packing list that accompanies the equipment. Ensure that the report and the packing list are signed by yourself and also by the transport agent, and send a copy of these documents to:
 - ▶ the transport company,
 - ▶ Kontron.

2.1.2 Unpacking

Unpacking the equipment must be carried out under the supervision of an authorized technician.

- > Open the package and take out the items one by one.
- > Inspect each item and make a note of any possible defects (scratches, marks or blemishes, damaged cables, etc.). If necessary, make a report of any damage or defects.
- > Check the equipment against the packing list and report any missing items.



It is recommended that you keep the package and the anti-shock protection. This will be required if you decide to move your system to a different site.

2.2 System Identification

An identification label is available on the left side of the system.

Label data:

- ▶ Model: TRACE-B304-TR
- ▶ S/N: xxxxxxxxxxxx (13 digits chronologic Serial Number)
- ▶ Rev: 200300000x (4 first digits: Engineering Change Level)

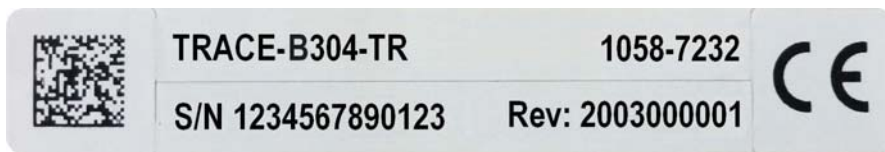

Figure 2: Identification Label Location



First series Identification Labels may be as follows:



- ▶ S/N: xxxx (4 digits chronologic Serial Number)
- ▶ Rev: xxxxx (5 digits Engineering Change Level)

2.3 System Specification

The following table provides the main specifications for the TRACe-TR Family.

	TRACe B304-TR	TRACe B314-TR	TRACe G304-TR	TRACe M304-TR	TRACe V304-TR
Processor	Intel® Atom™ Bay Trail-I Platform E3845 quad cores @ 1.91 GHz				
Memory	2 GB DDR3 with ECC				
Storage	EMMC 8 GB SLC Flash soldered				
Connectivity					
Operational Side	1x DCIN M12 2x M12 GbE (10/ 100/1000BASE-T) 2x Serial SUBD9 for RS232/422/485 1x Audio SUBD9 1x GPIO SUBD25				
		1x USB M12	3x SMA for GSM/GPS	2x SUBD9 for MVB	2x removable drive bays
Maintenance Side	1x USB (high speed) 1x USB 3.0 (3.0 only) port [BIOS configurable] 1x RJ-45 GbE (10/100/1000BASE-T) 1x RJ-12 RS-232 for processor and HMU				
			3x RP-SMA for WiFi (3T3R)	2x RP-SMA for WiFi (2T2R)	2x RP-SMA for WiFi (2T2R)
Software	Linux: Refer to TRACe-TR Family User's Manual. Windows: Refer to TRACe-TR Family User's Manual. Specific TRACe-TR tools package and live demo image will be made available on TRACe-TR Family Kontron Web Site (download section).				
Management					
Operational Side	Status LED: Power status LED				
Maintenance Side	Status and User LEDs: L1: User1 L2: User0, L3: Alarm/HMU, L4: Sys/SATA, L5: Power Status				
Dimensions	See Figure 3 page 6				See Figure 4 page 6
Weight	~ 2.5 kgs	~ 2.5 kgs	~ 2.7 kgs	~ 2.7 kgs	~ 3.7 kgs
Warranty	2 years				

Table 1: Technical Specifications of the TRACe-TR Family

» Dimensions

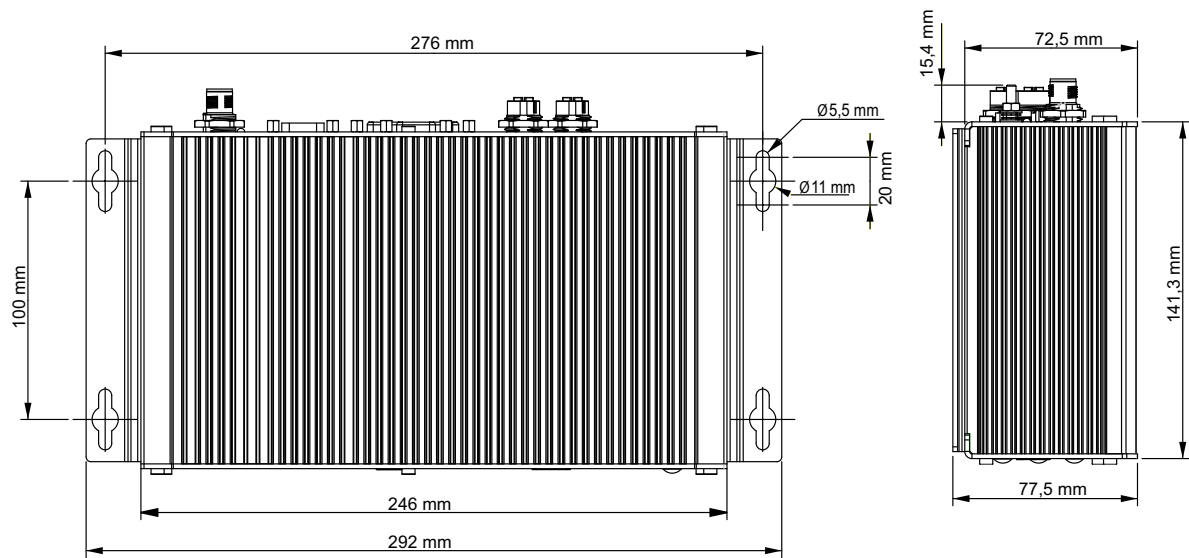

Figure 3: TRACe B304-TR, TRACe B314-TR, TRACe G304-TR, TRACe M304-TR Dimensions

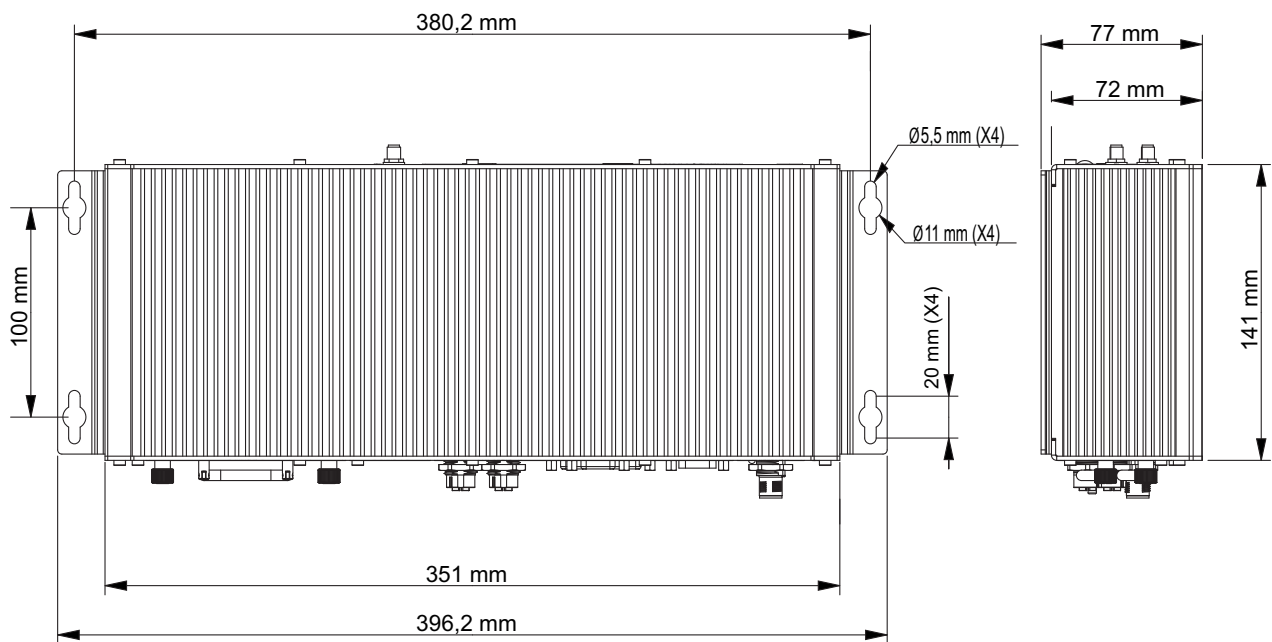

Figure 4: TRACe V304-TR Dimensions

2.4 Operational Side: I/O Connectors Pinout

2.4.1 DC IN: External PSU M12 Connector, Male, 4 Pin, A coded.



Figure 5: DC IN Connector

» Pin Configuration

Pin	Pin Name	Signal Name
1	VIN+	POWER IN + (+VDC)
2	VIN-	POWER IN- (GND)
3	IGN	Ignition (IGN)
4	NC	NC
Chassis	SHLD	Chassis ground (Shield)

Table 2: DC IN Pin Configuration

To power-on the system, you need a power cable with M12 Connector Female 4 Pin A-Coded in one end to fit the DC IN connector.

The power cable is included in TRACE-KIT-CAB-EVAL cable kit to be purchased separately.

According to the above pinout, free ends of this cable must be wired as follows (refer to section 2.7.1 page 22):

- ▶ Brown: +VDC
- ▶ White: -VDC
- ▶ Blue: IGN (+VDC to Power On)

IGN can be directly connected to VDC to have the system always on when VDC is applied, or connected to VDC through a switch to power the system on/off with VDC kept applied.

A power off controlled by the IGN signal has the same impact than removing VDC: all PSUs are switched off including standby power supplies. However using IGN to power on/off is recommended because this enables some extra features such as an automatic system shutdown with a delayed power-off when the IGN signal is disabled, or a system wakeup from sleep by toggling the IGN signal.



Even if IGN is expected to be connected to VDC, it can be alternatively connected to another voltage source with same GND(POWER IN-) and a voltage in the same range than the one required for VDC.

VDC and IGN voltage range to GND: 24 VDC-110 VDC nominal (19.5 VDC min – 126 VDC max).

Current on IGN for all IGN voltage range: around 4 mA

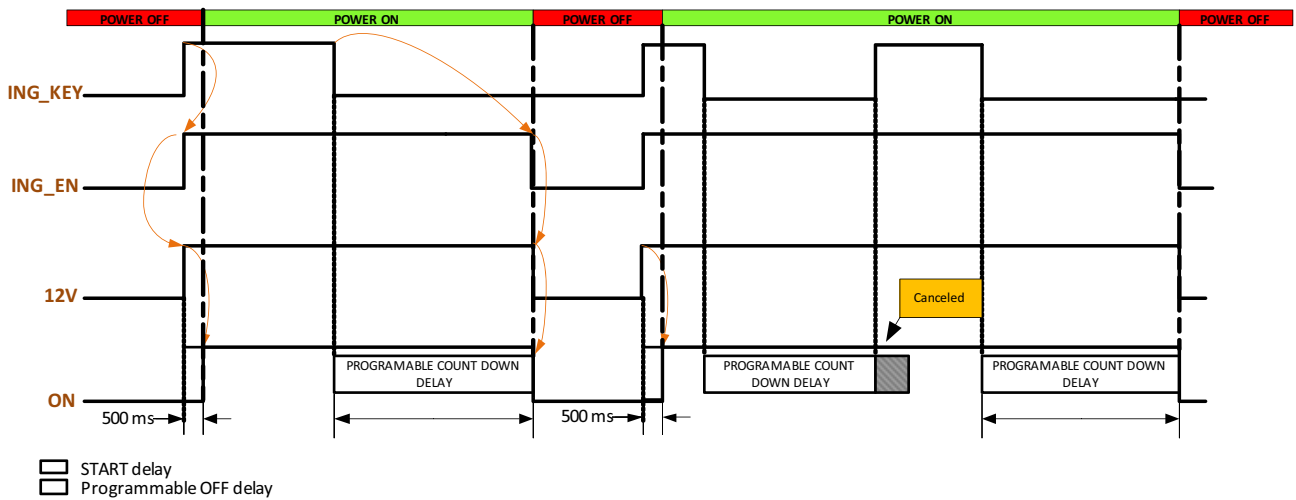
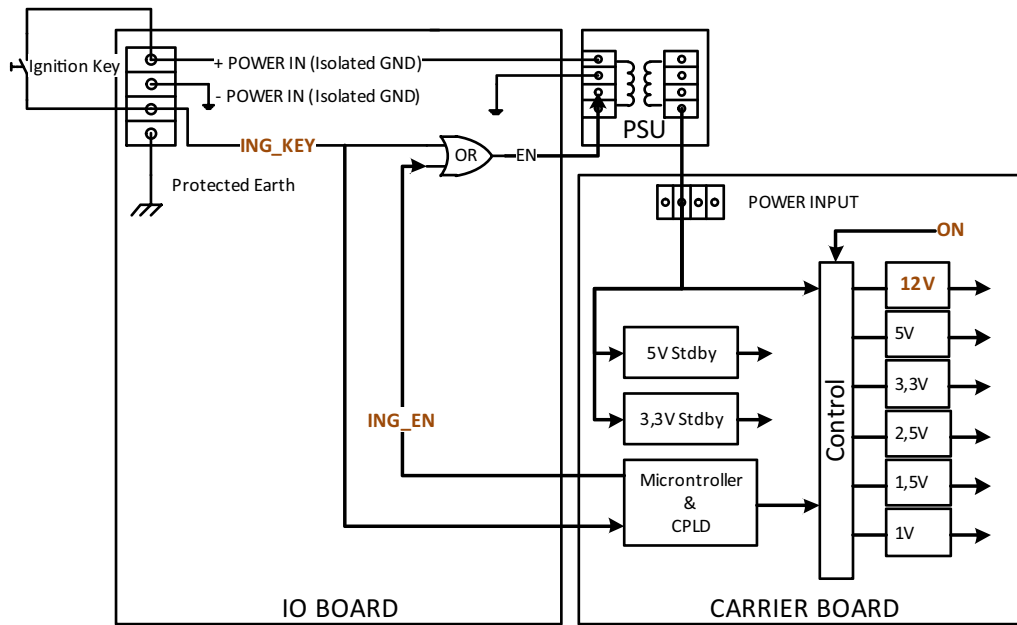
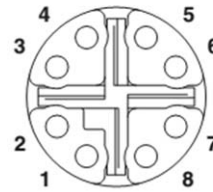

Figure 6: Ignition Implementation

2.4.2 LAN B, LAN C: Ethernet M12 Connectors, Female, 8 Pin, X coded.



View from Receptacle Side

Figure 7: LAN B, LAN C Connectors

HMU 10/100 Ethernet interface can be routed to LAN-C (can be selected by the trace_config tool -refer to 2.8.2 “Play/TRACe Configuration” page 25-)

» Pin Configuration

Pin	Pin Name
1	DA+
2	DA-
3	DB+
4	DB-
5	DD+
6	DD-
7	DC-
8	DC+

Table 3: LAN B, LAN C Connectors Pin Configuration

2.4.3 COM B, COM C: Serial SUBD9 Connectors, Male, 9 Pin.

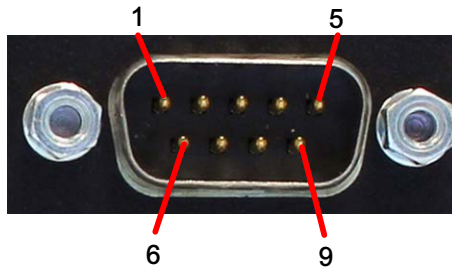

Figure 8: COM B, COM C Connectors

» Pin Configuration

Pin	RS-232	RS-422/RS-485 Full Duplex	RS-422/RS-485 Half Duplex
1	N.C.	N.C.	N.C.
2	RX	RX+ (A)	N.C.
3	TX	TX- (Z)	TX-/RX- (Z/B)
4	N.C.	N.C.	N.C.
5	GND	N.C.	N.C.
6	N.C.	N.C.	N.C.
7	RTS	TX+ (Y)	TX+/RX+ (Y/A)
8	CTS	RX- (B)	N.C.
9	N.C.	N.C.	N.C.

Table 4: COM B, COM C Connectors Pin Configuration



Two naming conventions are used for RS-422/RS-485 differential signals, they match each other as follows : TX+ = Y, TX- = Z, RX+ = A, RX- = B

The serial mode and duplex can be set using the `trace_config` tool (refer to 2.8.2 “Play/TRACe Configuration” page 25).

When in 485 mode, the RTS signal from the UART is no more available on the connectors but is used as a "TX enable" (transmit enable): when RTS is high (logic 1 driven by UART), TX is enabled. TX is disabled by switching RTS low (under Linux OS, RTS can be managed by the `TIOCMGET/TIOCMSET` IOCTL, using the `TIOCM_RTS` flag)

COM-B is muxed between UART (default) and HMU (can be selected by the `trace_config` tool).

When in HMU mode, transmit is always enabled (RTS always at 1) so only RS-232 and RS-422 are supported.

See COM-A for HMU serial line routing to COM-A or COM-B

2.4.4 GPIO: SUBD25 Connector, Female, 25 Pin.



Figure 9: GPIO Connector

» Pin Configuration

Pin	Signal Name	Pin Name	Signal Name
1	GND_GPIO_ISO	14	GPIO_IN[0]
2	GND_GPIO_ISO	15	GPIO_IN[1]
3	GND_GPIO_ISO	16	GPIO_IN[2]
4	GND_GPIO_ISO	17	GPIO_IN[3]
5	N.C.	18	N.C.
6	N.C.	19	N.C.
7	N.C.	20	N.C.
8	N.C.	21	24 VISO (external)
9	GND_GPIO_ISO	22	GPIO_OUT[0]
10	GND_GPIO_ISO	23	GPIO_OUT[1]
11	GND_GPIO_ISO	24	GPIO_OUT[2]
12	GND_GPIO_ISO	25	GPIO_OUT[3]
13	GND_GPIO_ISO	26, 27	Shield

Table 5: GPIO Connector Pin Configuration

24 VISO DC voltage (8 VDC min - 29 VDC max) must be applied to pin 21 to power the isolated GPIO logic.

GPIO_OUT[n] are open-collector outputs, enabled (driven low to GND_GPIO_ISO) when a logic 1 is written from software. Each output can sink up to 20 mA. Maximum voltage on GPIO_OUT[n] (to GND_GPIO_ISO) is 29 VDC.

GPIO_IN[n] are inputs that are read at 1 from software when at logic level high (24V logic).

Maximum voltage on GPIO_IN[n] (to GND_GPIO_ISO) is 29 VDC.

These inputs have an hysteresis (around 1V); level high is above 17V; level 0 under 16V.

GPIO_OUT[n] and GPIO_IN[n] can have a voltage greater than 24 VISO provided that this voltage does not exceed 29 VDC.

2.4.5 Audio: SUBD9 Connector, Female, 9 Pin.

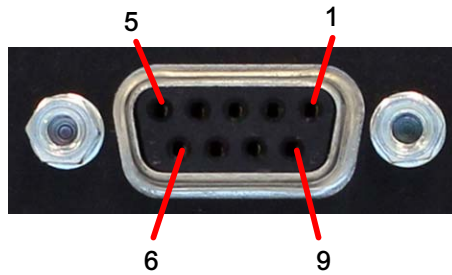

Figure 10: Audio Connector

» Pin Configuration

Pin	Signal Name
1	LINE_OUT_L (Headphone)
2	GND_AUDIO
3	LINE_OUT_R (Headphone)
4	GND_AUDIO
5	AUDIO LINE MICBIAS
6	5V (internal)
7	LINE_IN_L (Microphone)
8	GND_AUDIO
9	LINE_IN_R (Microphone)

Table 6: Audio Connector Pin Configuration

2.5 Maintenance Side: I/Os Connector Pinout

2.5.1 COM A: RJ-12 Connector

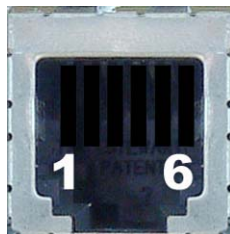

Figure 11: COM A Connector

» Pin Configuration

Pin	Signal Name
1	HMU TX
2	GND
3	COMe TX
4	COMe RX
5	GND
6	HMU RX

Table 7: COM A Connector Pin Configuration

HMU serial line on COM-A (default) can be routed to COM-B instead (can be selected by the `trace_config` tool -refer to 2.8.2 “Play/TRACe Configuration” page 25-).

COM-B mode	COM-A	COM-B	Comments
UART	TX = HMU TX RX = HMU RX	TX = UART TX RX = UART RX RTS = UART RTS	RTS is available on COM-B only in RS-232 mode
HMU	TX = HMU TX RX = --	TX = HMU TX RX = HMU RX RTS = 1	TX output of HMU is available on both connectors RTS is available on COM-B only in RS-232 mode

2.5.2 LAN A Gigabit Ethernet Port

The TRACe-TR have a Gigabit Ethernet port:

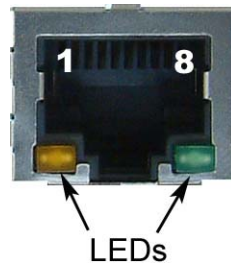

Figure 12: LAN A Gigabit Ethernet Connector

» Pin Assignment

PIN	10BASE-T		100BASE-TX		1000BASE-T	
	I/O	SIGNAL	I/O	SIGNAL	I/O	SIGNAL
1	O	TX+	O	TX+	I/O	BI_DA+
2	O	TX-	O	TX-	I/O	BI_DA-
3	I	RX+	I	RX+	I/O	BI_DB+
4	-	-	-	-	I/O	BI_DC+
5	-	-	-	-	I/O	BI_DC-
6	I	RX-	I	RX-	I/O	BI_DB-
7	-	-	-	-	I/O	BI_DD+
8	-	-	-	-	I/O	BI_DD-
Shell	Chassis Ground					

Table 8: Gigabit Ethernet Connector Pin Assignment



The Ethernet transmission should operate using a CAT5 cable with a maximum length of 100 m.

The Ethernet connectors are available as RJ-45 connectors with tab down.

2.5.3 USB B: USB 3.0 Connector

The TRACe-TR have a USB 3.0 compliant connector. It can work as a USB 2.0 connector or as a USB 3.0 connector.

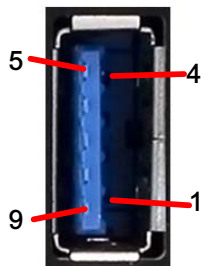

Figure 13: USB 3.0 Connector

» Pin Assignment:

PIN	SIGNAL	DESCRIPTION	I/O
1	+5V protected	USB power	-
2	DATA-	Differential USB-	I/O
3	DATA+	Differential USB+	I/O
4	GND	Ground	-
5	USBSS_RX-	Differential USB Receive -	I
6	USBSS_RX+	Differential USB Receive +	I
7	GND	Ground	-
8	USBSS_TX	Differential USB Transmit -	O
9	USBSS_TX+	Differential USB Transmit +	O

Table 9: USB 3.0 Connector Pin Assignment

2.5.4 USB A: USB 2.0 Connector

The TRACe-TR have a USB 2.0 connector type A right angle

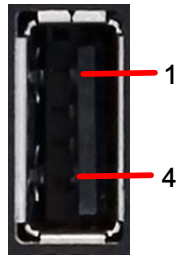

Figure 14: USB 2.0 Connector

» Pin Assignment

PIN	SIGNAL	FUNCTION	I/O
1	VCC (+5V Protected)	VCC	--
2	USB_D-	Differential USB-	I/O
3	USB_D+	Differential USB+	I/O
4	GND	GND	--

Table 10: USB 2.0 Connector Pin Assignment

All the signal lines are EMI-filtered.

2.5.5 SIM CARDS: SIM Connectors

The TRACe-TR have two SIM connectors

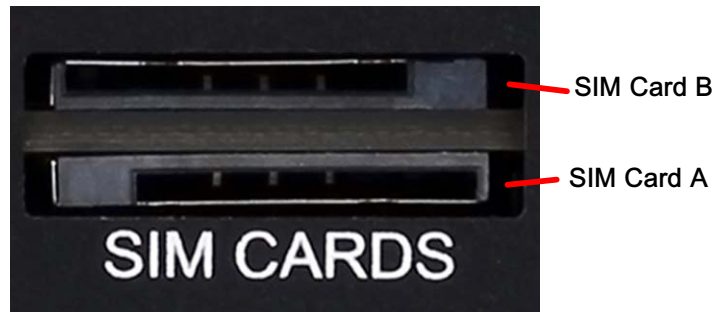

Figure 15: SIM Connectors

» Pin Assignment

PIN	NAME	SIGNAL DESCRIPTION
1	VCC	VCC
2	Reset	RST
3	Clock	CLK
4	SW1	SIM Detection
5	GND	GND
6	VPP	Not Connected
7	DATA	DATA
8	SW2	GND

Table 11: SIM Connector Pin Assignment

2.5.6 DP: DisplayPort Connector

The TRACe-TR have a DisplayPort Interface

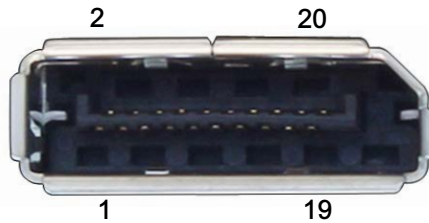

Figure 16: DisplayPort Connector

» Pin Assignment

PIN	SIGNAL	FUNCTION
1	ML_Lane 0 (p)	Lane 0 (positive)
2	GND	Ground
3	ML_Lane 0 (n)	Lane 0 (negative)
4	ML_Lane 1 (p)	Lane 1 (positive)
5	GND	Ground
6	ML_Lane 1 (n)	Lane 1 (negative)
7	ML_Lane 2 (p)	Lane 2 (positive)
8	GND	Ground
9	ML_Lane 2 (n)	Lane 2 (negative)
10	ML_Lane 3 (p)	Lane 3 (positive)
11	GND	Ground
12	ML_Lane 3 (n)	Lane 3 (negative)
13	GND	Ground
14	GND	Ground
15	AUX CH (p)	Auxiliary Channel (positive)
16	GND	Ground
17	AUX CH (n)	Auxiliary Channel (negative)
18	Hot Plug	Hot Plug Detect
19	Return	Return for power
20	DP_PWR	Power for connector

Table 12: DisplayPort Connector Pin Assignment

2.6 Specific I/Os

2.6.1 USB C: M12 Connector Female, 5 Pin, A coded.



Available on TRACe B314-TR only.

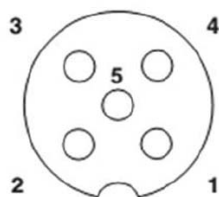

View from Receptacle Side

Figure 17: USB C Connector

» Pin Configuration

Pin	Pin Name
1	D+
2	5V
3	N.C.
4	D-
5	GND
Chassis	Shield

Table 13: USB C Connector Pin Configuration

2.6.2 X1, X2: SUBD9 Connectors, 9 Pin (X1: Male, X2: Female)



Available on TRACe M304-TR only.

This paragraph applies to EMD segments, only

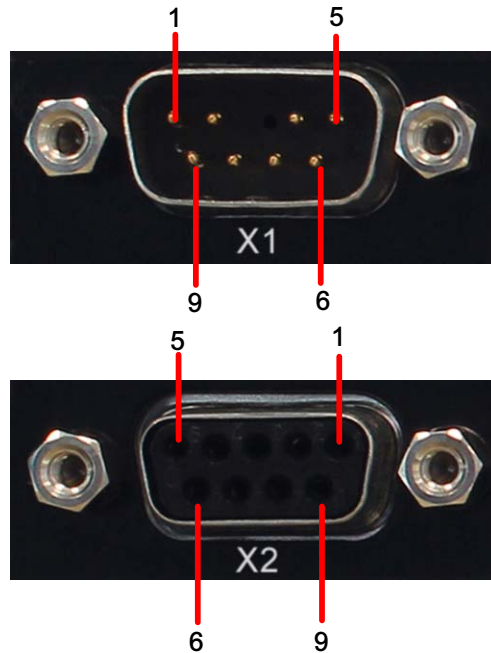

Figure 18: X1, X2 Connectors

» Pin Configuration

Pin#	Pin Name	Input / Output as seen from D017M	Description
1	A.data.P	bidirectional	Non- inverted MVB bus line
2	A.data.N	A.data.N	Inverted MVB bus line A
3	NC	-	Not connected
4	B.data.P	bidirectional	Non- inverted MVB bus line
5	B.data.N	B.data.N	Inverted MVB bus line B
6.7	A.term	Passive resistor	Termination resistor between two pins.
8.9	B.term		
shell	Shield	-	Connection to shield resp. housing.

2.6.3 A4, A5, A6 Connectors (“OPT” Plate on Operational Side)



Available on TRACe G304-TR only.

» LTE/UMTS/GNSS Configuration

Channel	SMA
Main RF (Rx / Tx path)	A4
GNSS (GPS / GLONASS)	A5
Diversity / MIMO	A6



Figure 19: A4, A5, A6 Connectors



Leaving SMA connectors without antennas while using LTE / GNSS can affect performance and may damage the module, therefore Kontron recommends to connect antennas to all available SMA connectors

2.6.4 A1, A2, A3 Connectors (Maintenance Side)



Available on TRACe G304-TR, TRACe M304-TR and TRACe V304-TR only.

» WiFi Configuration

Channel	RP-SMA
Main CH0	A1
Aux CH1 (MIMO)	A2
Aux CH2 (MIMO)	A3 (*)

(*) Available on TRACe G304-TR only (for MIMO 3T3R)



Figure 20: A1, A2, A3 Connectors



Leaving RP-SMA connectors without antennas while using Wi-Fi can affect performance and may damage the module, therefore Kontron recommends to connect antennas to all available RP-SMA connectors.

2.7 Optional Cables Kits

2.7.1 TRACE-KIT-CAB-EVAL

Set of Cables for TRACe-TR Family evaluation, consisting of:

- ▶ 1x CABLE ASSY: Power (M12-A coded to free end),
- ▶ 1x ETHERNET (M12-X coded to RJ-45),
- ▶ 1x Serial (RJ-12 to dual DB9)

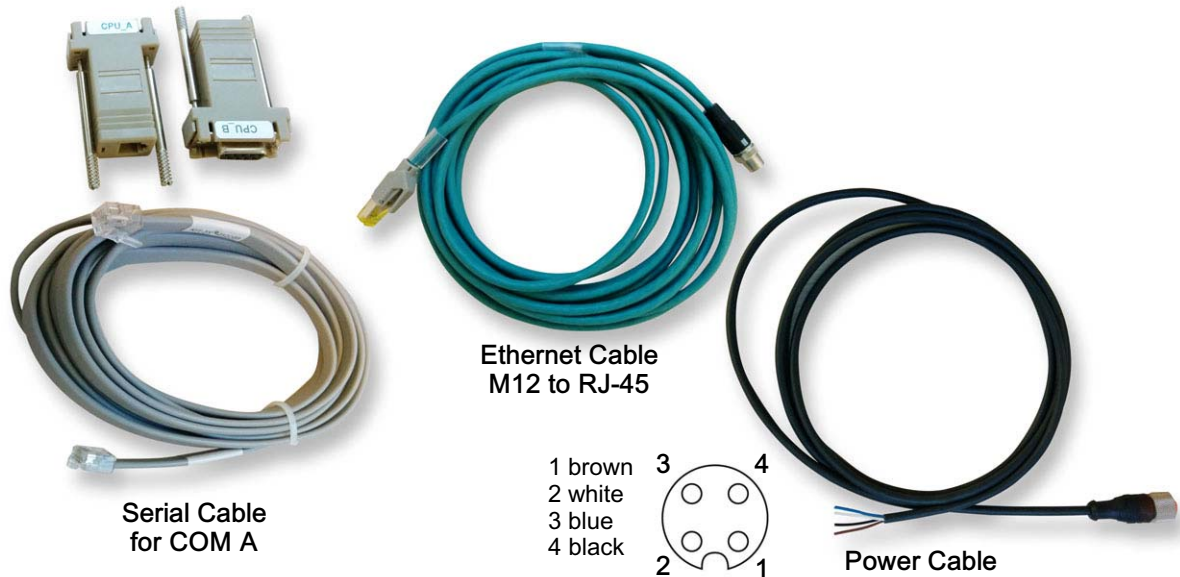

Serial Cable for COM A: CPU_A to connect to COMe CPU, CPU_B to connect to HMU

2.7.2 TRACE-KITSATA-1

Set of SATA cables to install one 2,5" SSD (for TRACe B304-TR only), consisting of:

- ▶ 1xSATA Power cable,
- ▶ 1x SATA Data cable,
- ▶ 4x screws and spacers

2.7.3 TRACE-STARTERKIT-1

Complete set of cables / accessories for TRACe evaluation, consisting of :

- ▶ 1x AC/DC converter cable assembly for DC IN
- ▶ 1x USB Key Fedora 22 TRACe Live Image
- ▶ 1x M12 to RJ-45 Ethernet Cable
- ▶ 1x Display port to VGA adapter
- ▶ 1x Serial cable (RJ-12 to dual DB9: CPU_A, CPU_B) : 1x KIT-2X-RJ12DB9
- ▶ 3x Wi-Fi antennas Dual Band 2,4 GHz - 5 GHz,
- ▶ 2x 3G/LTE antennas 5dBi,
- ▶ 1x GPS antenna

2.8 Plug and Play with TRACe-TR Family

The following sections are valid for a Linux operating system with its TRACe BSP installed. A live CD Fedora image is available on the Kontron Web Site under TRACe B304-TR download section (<http://www.kontron.com/products/systems-and-platforms/transportation-systems-and-platforms/trace--intelligent-transportation-computer/>).

2.8.1 Plug

Earth ground connection to vehicle’s chassis or a central grounding point shall remain connected. The earth ground cable shall be the last disconnected or the first connected during operations of cabling.

To power-on the TRACe-TR Operational Box Computer, you need to attach a Power Supply Cable (refer to section 2.7 page 22) to the DC IN connector (PSU wide range 24 VDC-110 VDC). On the other side, it has to be cabled to a DC power source (24 VDC minimum) following the pin-out description in the above section 2.4 “I/O Connectors Pinout” page 7.



EN60950 Limitation for TRACe with an E.C. Level inferior to 30000: CE Marking only applies for nominal input tension 24, 36 and 48VDC. Refer to TRACe-TR User’s Manual.

Two methods:

1. Graphical session (recommended):
 - ▶ Connect a display for graphical session (display and cables not provided) to the DisplayPort on Maintenance side.
 - ▶ Plug a USB hub for keyboard and mouse in USB A connector on Maintenance side.
2. Serial console:
 - ▶ Connect to the TRACe-TR via RJ-12 serial connector on maintenance side using a cable KIT-2X-RJ12DB9 (included in TRACE-KIT-CAB-EVAL) and use a serial terminal emulator as putty or minicom for example.
 - ▶ Parameters for this serial line interface are: 115200 bauds, 8-bit, no parity, no flow control.

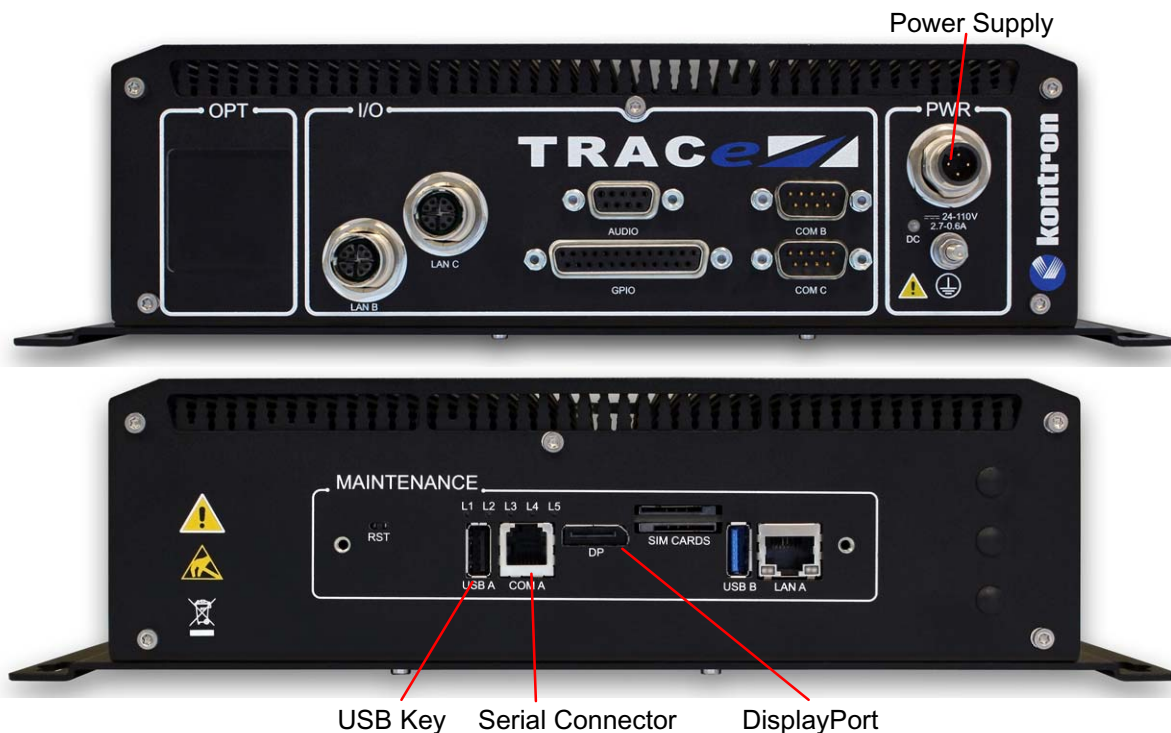

Figure 21: Connecting TRACe-TR Family

» To start the system

- > Power on the DC power supply module via DC IN connector (section 2.4 “I/O Connectors Pinout” page 7) and then turn on the ignition key. As long as the ignition signal is not connected to the +POWER IN (power supply connector pin 1) the system cannot start (refer to Figure 8 - Ignition Implementation page 10).
- > A Linux login prompt should appear shortly.

The system can also be configured to stay off when ignition signal is switched on, and start on assertion of GPIO_IN[0] or GPIO_IN[1] (configurable using `trace_config` -refer to 2.8.2 “Play/TRACe Configuration” page 25-) or on HMU request

In this case, when waiting to start, the Power status LED is flashing twice every 2 seconds.

» To stop the system

- > **Manual method (Default):**

Shutdown the OS: with the shutdown menu in graphical session, or using the «`halt-p`» command from a Linux terminal.

When the shutdown is completed (Power status LED is flashing once every 2 seconds), you can either:

- ▶ switch off the Igniton key (IGN signal on the DC IN connector), then optionally remove the power (+VDC on the DC IN connector).
- ▶ or directly remove the power, if you don't have the Ignition key or don't want to use it.

- > **Automatic method:**

Just switch off the ignition signal: this automatically performs a shutdown, and once the shutdown is completed, a power-off. After that you can optionally remove the power (+VDC on the DC IN connector).

This requires the `trace-poweroffd` daemon to be running. You can tell `systemd` to start it at boot time as follows:

```
systemctl enable trace-poweroffd
```

and start it right now without rebooting:

```
systemctl start trace-poweroffd
```

» Suspend the system

Suspend the OS: with `suspend` menu in graphical session, or "`systemctl suspend`" in a Linux terminal (as root).

The Power status LED is flashing once every 2 second.

To resume, the following methods are supported :

- ▶ Switch the ignition signal off and on fastly (less than 750mS).
- ▶ Send a Wake-On-Lan Ethernet packet to the system on LAN-B or LAN-C interfaces
- ▶ Assertion of a GPIO_IN[0] or GPIO_IN[1] (configurable using `trace_config`)
- ▶ Reset switch on maintenance side
- ▶ HMU request (not implemented)

2.8.2 Play

- > Plug the system for a graphical session as described in section 2.8.1 “Plug” page 23.
- > Plug the live image support (DVD or USB) on the system.
- > Power on the system then select the boot device by pressing <F5> on keyboard.
- > A desktop workstation will appear shortly:

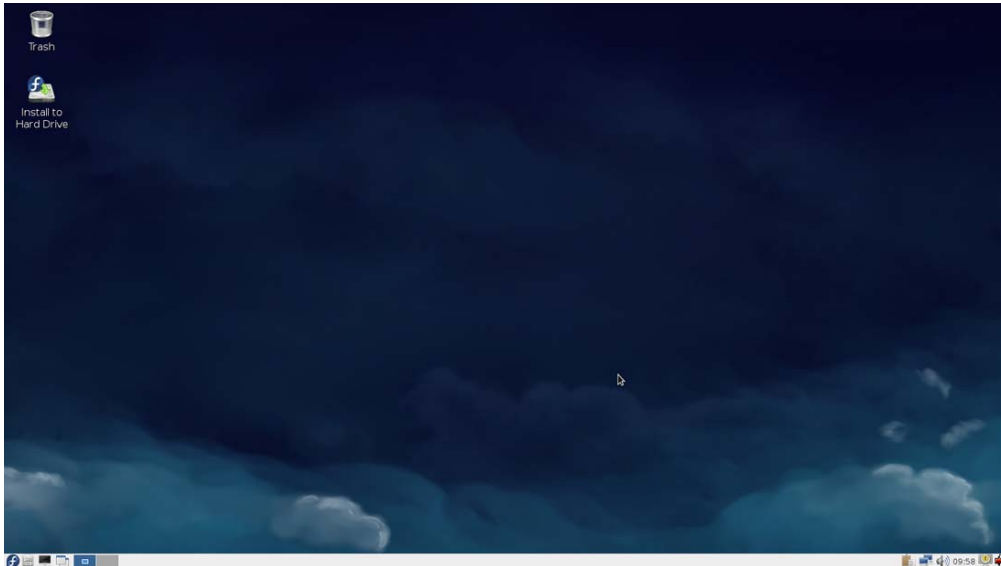

» TRACe Configuration :

Some configuration settings are available under BIOS setup, however TRACe specific settings are managed by the OS tool `trace_config`

By default, this tool works on saved settings that are applied at power-on (ignition signal on).

It is also possible to work on the current settings, to temporarily change some settings (changes are lost at power-off).



This command must be run as root user.

To display saved settings:

```
[root@trace-board ~]# trace_config
Saved configuration :
--serial    232      : RS232 mode on COM-B/COM-C serial lines
--serial    full     : Full duplex on COM-B/COM-C serial lines
--tpm       on       : Second TPM chip ON
--poweron   start    : Start when ignition key is switched ON
--dport     maint    : DisplayPort on maintenance plate connector
--sata      minil   : SATA interface to mini socket #1
--sim       0a1b    : mini socket #0 to SIM-A + socket #1 to SIM-B
--gpiowake  off      : Wakeup from GPI1 NOT enabled
--gpiowake  off      : Wakeup from GPIO NOT enabled
--lanc      i210    : LAN-C connector for Intel i210 ethernet
--comb      uart    : COM-B connector for PCIe UART
[root@trace-board ~]#
```

To display current settings:

```
[root@trace-board ~]# trace_config -c
Current configuration :
--serial      232      : RS232 mode on COM-B/COM-C serial lines
--serial      full     : Full duplex on COM-B/COM-C serial lines
--tpm         on       : Second TPM chip ON
--poweron     start    : Start when ignition key is switched ON
--dport       maint    : DisplayPort on maintenance plate connector
--sata        mini1    : SATA interface to mini socket #1
--sim         0a1b     : mini socket #0 to SIM-A + socket #1 to SIM-B
--gpiowake    off      : Wakeup from GPI1 NOT enabled
--gpiowake    off      : Wakeup from GPIO NOT enabled
--lanc        i210     : LAN-C connector for Intel i210 ethernet
--comb        uart     : COM-B connector for PCIe UART
--offdelay    3        : Power off delay in units of 1/4 seconds (0 to 255)
--mini0       absent   : Mini socket #0 PCIe device NOT present
--mini1       absent   : Mini socket #1 device NOT present (mPCIe or mSATA)
--mini1sata   absent   : Mini socket #1 SATA device NOT present
--mini2       absent   : Mini socket #2 PCIe device NOT present
--mode        normal   : System running in normal mode
--ledsysr     off      : LED SYS red OFF
--ledalarmr   off      : LED ALARM red OFF
--ledusr1     off      : LED USER1 is OFF
--ledusr0     off      : LED USER0 is OFF
--sysstate    0        : Current system state code (0 to 15, updated by soft)
--cpldrev     0x04     : cPLD revision/version on carrier board
[root@trace-board ~]#
```

The help gives the list of all possible settings and their supported values:

```
[root@trace-board ~]# trace_config -h
```

To also see debug settings:

```
[root@trace-board ~]# trace_config -d -h
```



Some of them are read-only or/and only apply to the current or saved settings.

Refer to TRACe-TR User's Manual for full command output.

> EXAMPLES :

- ▶ Switch LED L2 (User0) to red right now:

```
[root@trace-board ~]# trace_config -c --ledusr0 red
```

- ▶ Get current LED L2 (User0) state:

```
[root@trace-board ~]# trace_config -c --ledusr0
Current :
--ledusr0  red      : LED USER0 is RED
[root@trace-board ~]#
```

- ▶ Set serial lines to 422/485 at next power-on (saved setting):

```
[root@trace-board ~]# trace_config --serial 485
```

- ▶ Set serial lines to 422/485 right now (current setting):

```
[root@trace-board ~]# trace_config -c --serial 485
```

- ▶ Get serial lines configuration for both saved and current settings:

```
[root@trace-board ~]# trace_config -c -s --serial
Saved :
  --serial    485      : RS422/485 mode on COM-B/COM-C serial lines
  --serial    full    : Full duplex on COM-B/COM-C serial lines
Current :
  --serial    485      : RS422/485 mode on COM-B/COM-C serial lines
  --serial    full    : Full duplex on COM-B/COM-C serial lines
[root@trace-board ~]#
```

2.9 Device Management

2.9.1 Power status LED



Figure 22: Power On LED

	State	Meaning
POWER	OFF	System power off (Ignition key OFF)
	GREEN PULSE THREE TIMES every 4 seconds	System power off with Igniton key ON (forced off by cPLD REG_POWER[FORCE_OFF] bit set by HMU or by software)
	GREEN	System running
	GREEN PULSE ONCE every 2 seconds	System in standby mode (S3,S4 or S5 state)
	GREEN PULSE TWICE every 2 seconds	System waiting for power-on event (GPI, uC command, ...)
	SLOW BLINKING GREEN with period 1 second	System about to power-off (power off delay)
	FAST BLINKING GREEN with period 0.5 second	In debug mode
	ORANGE (red+green)	System reset from COME (CB_RESET# asserted)
RED	Power error Power supplies are switched off and an error code is reported on USER0/1 LEDs	

2.9.2 Status and User LEDs

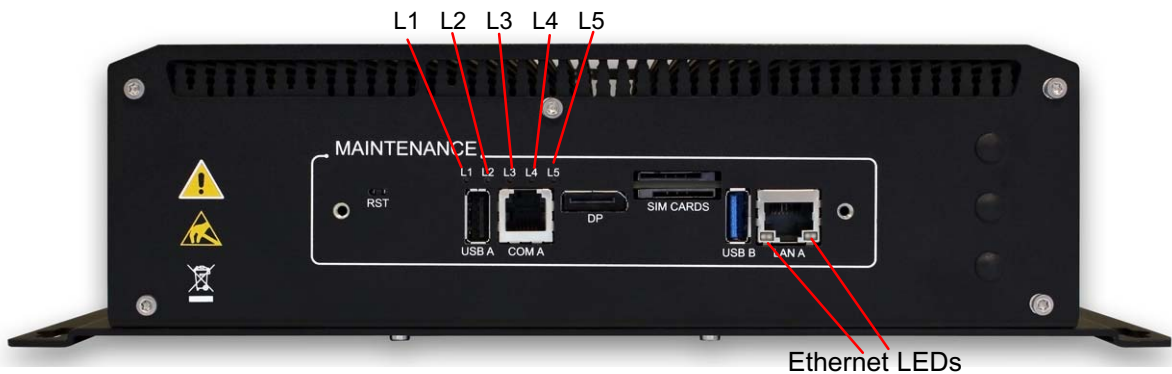

Figure 23: Status LEDs

2.9.2.1 Status User LEDS

Five Status User LEDs: L1 (User1), L2 (User0), L3 (Alarm/HMU), L4 (Sys/SATA), L5 (Power)

These LEDs are bicolor (red and green), giving 4 possible states (off, red, green, orange)

- ▶ L1 and L2 are controlled by the cPLD
- ▶ L3 and L4 are controlled by the cPLD for red color (Alarm, Sys) but not for green color (HMU, SATA)
- ▶ L5 (Power) has the same state than the Power status LED on operational side.

LED	State	Meaning
POWER ("L5")	OFF	System power off (Ignition key OFF)
	GREEN PULSE THREE TIMES every 4 seconds	System power off with Igniton key ON (forced off by cPLD REG_POWER[FORCE_OFF] bit set by HMU or by software)
	GREEN	System running.
	GREEN PULSE ONCE every 2 seconds	System in standby mode (S3,S4 or S5 state).
	GREEN PULSE TWICE every 2 seconds	System waiting a wakeup event to power-on.
	SLOW BLINKING GREEN with period 1 second	System about to power-off (power off delay).
	FAST BLINKING GREEN with period 0.5 second	In debug mode.
	ORANGE (red+green)	System reset from COME (CB_RESET# asserted).
	RED	Power error. Power supplies are switched off and an error code is reported on USER0/1 LEDs.
USER0 ("L2")	OFF or GREEN or ORANGE (red+green) or RED	Controlled by REG_LED register. May alternatively report are error code or a power state
USER1 ("L1")	OFF or GREEN or ORANGE or RED	Controlled by REG_LED register May alternatively report an error code or a power state
ALARM ("L3")	OFF or GREEN or ORANGE (red+green) or RED	RED color controlled by REG_LED register GREEN color is controlled by HMU (MICRO_LED_DEBUG2)
SYS ("L4")	OFF or GREEN or ORANGE (red+green) or RED	RED color controlled by REG_LED register. GREEN color is controlled by SATA interface (SATA_ACT#).

Table 14: Status User LEDs Description



This register shall also be readable and writable from the HMU.

When COME is powered on, all LEDs are switched on for a second to test LEDs (ORANGE, except ALARM and SYS that are RED)

All LEDs are available on the maintenance plate with the name "Lx" (x from 1 to 5; see above). The POWER LED is the only one also available on the operational plate (with the name "POWER").

To control the LEDs through the cPLD, the trace_config tool can be used (trace_config -c --ledXXXX YYYY)

When L5 (Power) is red (power error), an error code is reported on L1 (User1) and L2 (User0) as follows:

Error number	Error name	L1 (User1)	L2 (User0)
0	ERR_NO_ERROR	N/A	N/A
1	ERR_STDBY_5V_3V3	OFF	GREEN
2	ERR_SUS_S3	OFF	RED
3	ERR_3V3_5V	OFF	ORANGE
4	ERR_12V	GREEN	OFF
5	ERR_2V5	GREEN	GREEN
6	ERR_1V0	GREEN	RED
7	ERR_1V5	GREEN	ORANGE
8	ERR_UART	RED	OFF
9	ERR_PCIESW_LOCK	RED	GREEN
10	ERR_SUS_STAT	RED	RED
11	ERR_EMERGENCY_OFF	RED	ORANGE

2.9.2.2 Ethernet status LEDs

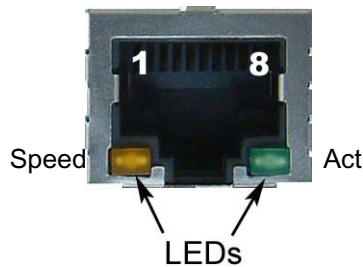

STATUS		SPEED LED yellow	ACT LED green
Ethernet link is not established		OFF	OFF
10/100 Mbps	Ethernet link established	OFF	ON
	Ethernet Link Activity	OFF	BLINK
1000 Mbps	Ethernet link established	ON	ON
	Ethernet Link Activity	ON	BLINK

Table 15: Ethernet LEDs Status Definition

2.9.3 Computer Reset



- > RST button on Maintenance rear side

Figure 24: Computer Reset

2.10 Health Management Unit Use Cases

The HMU implemented in a Microchip PIC32 microcontroller provides the following management facilities:

- ▶ **Inventory:** Vital Product Data of the TRACe-TR machine.
- ▶ **Supervision:** monitoring of thermal sensors, voltage sensors, health status of internal interfaces (I2C bus, devices, log events, ...).
- ▶ **Control Management:** This feature will be implemented later.

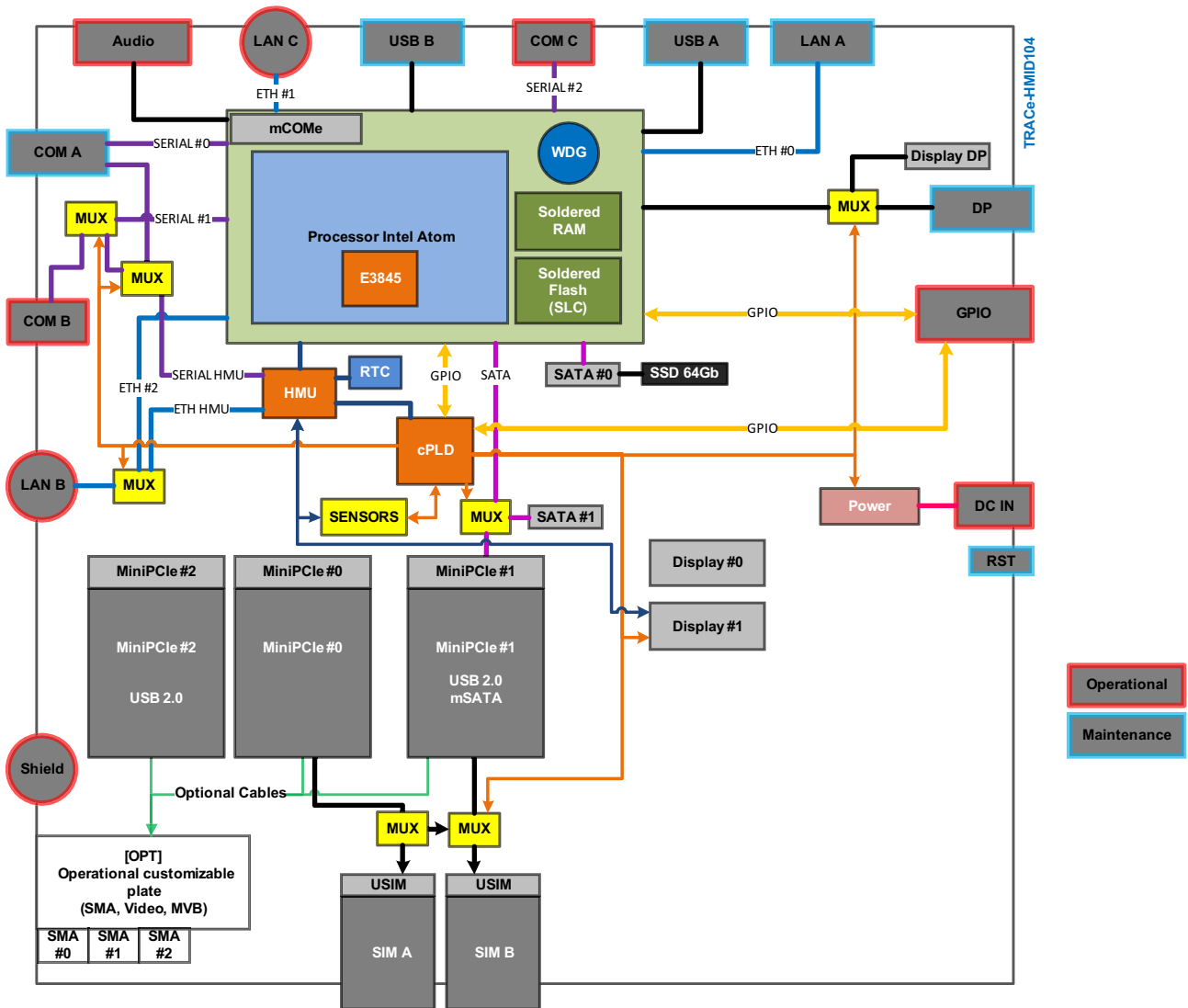

Figure 25: TRACe Block Diagram

2.10.1 In-Band Health Management

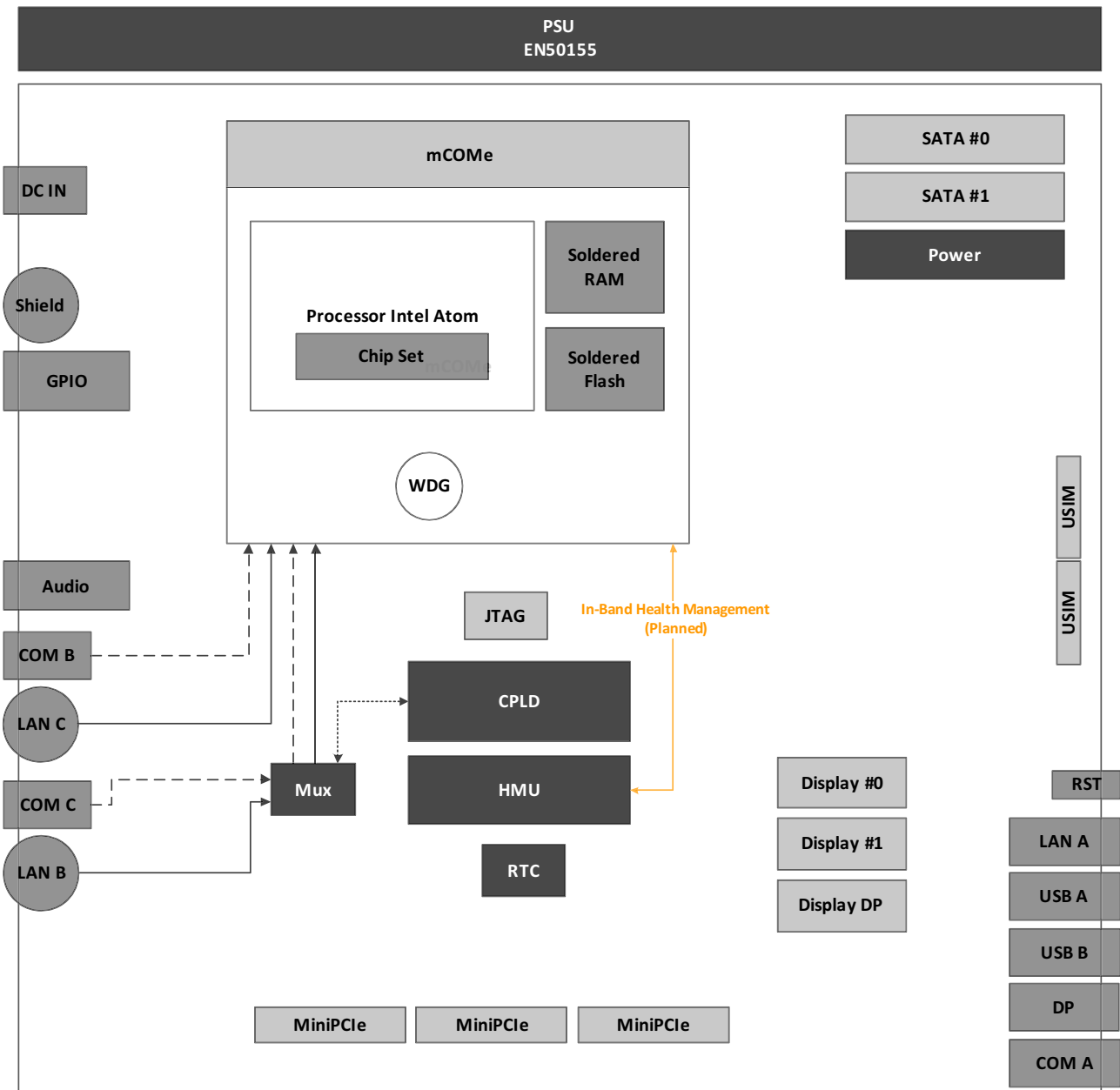

Figure 26: In-Band Health Management

2.11 Linux

2.11.1 BSS Overview

TRACe-TR Family BSS is based on :

- ▶ Fedora Core 22
- ▶ BSP of COMe
- ▶ TRACe-BSP package

BSS release is defined in /opt/TRACe-release



There are two accounts defined by default on the pre-installed systems:

- ▶ User "root" with default password "kontron"
- ▶ User "tech" with default password "tech"

2.11.2 OS Release

- ▶ Base Distribution Fedora 22
- ▶ Package Management DNF/RPM/TARBALLS
- ▶ Distribution Website <http://www.fedoraproject.org>
- ▶ Linux Kernel Linux-4.1
- ▶ X-Server Xorg 1.17

List of installed packages is provided with command :

```
tech # dnf list installed
```

2.11.3 Live CD Contents

A Fedora Live CD image is available online to get started with TRACe-TR Family platform. You can download it on the Kontron product website: <http://www.kontron.com/products/systems-and-platforms/transportation-systems-and-platforms/trace---intelligent-transportation-computer/trace-b304-tr.html>.

The Live CD is ready to use on your system as it is already pre-configured with the TRACe BSP.

You can choose to burn it on a DVD or more effective on a USB stick:

- ▶ Under Linux PC:

```
dd if=<your_image.iso> of=/dev/sd<your_device_id> bs=1M
```

- ▶ Under Windows PC:

We suggest to download and use "win32diskimager"

2.11.4 BSS Installation on HDD

From the Live media it is possible to install the BSS on the TRACe-TR Family HDD by executing the following.

Boot the system with Live media: Use <F5> key to select boot device.

The main desktop is displayed

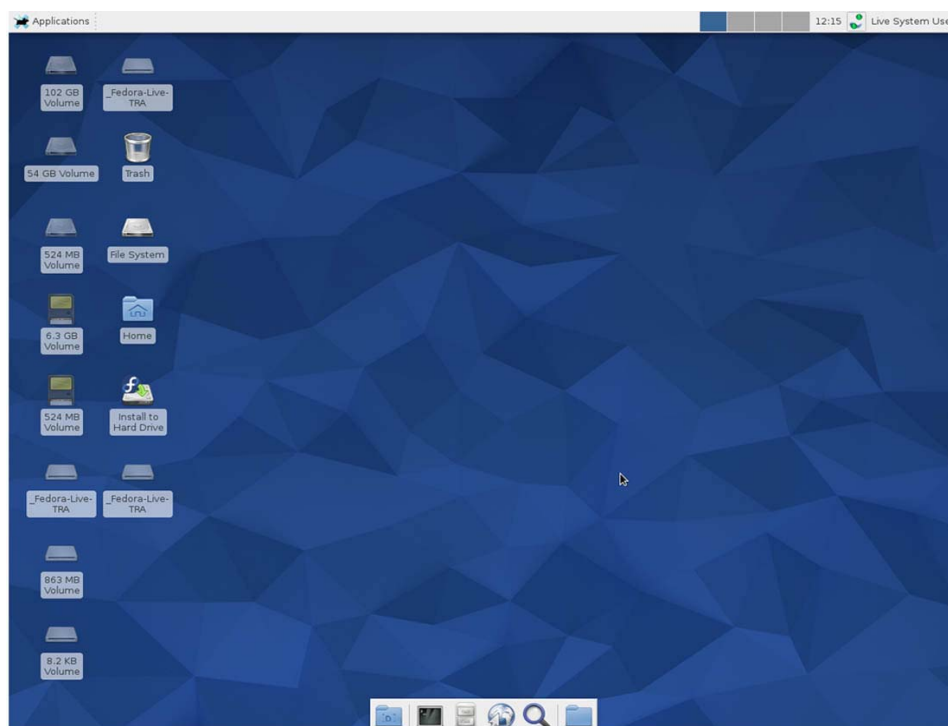

Click on the Desktop Icon : “Install to Hard Drive”

The installation language must be chosen:

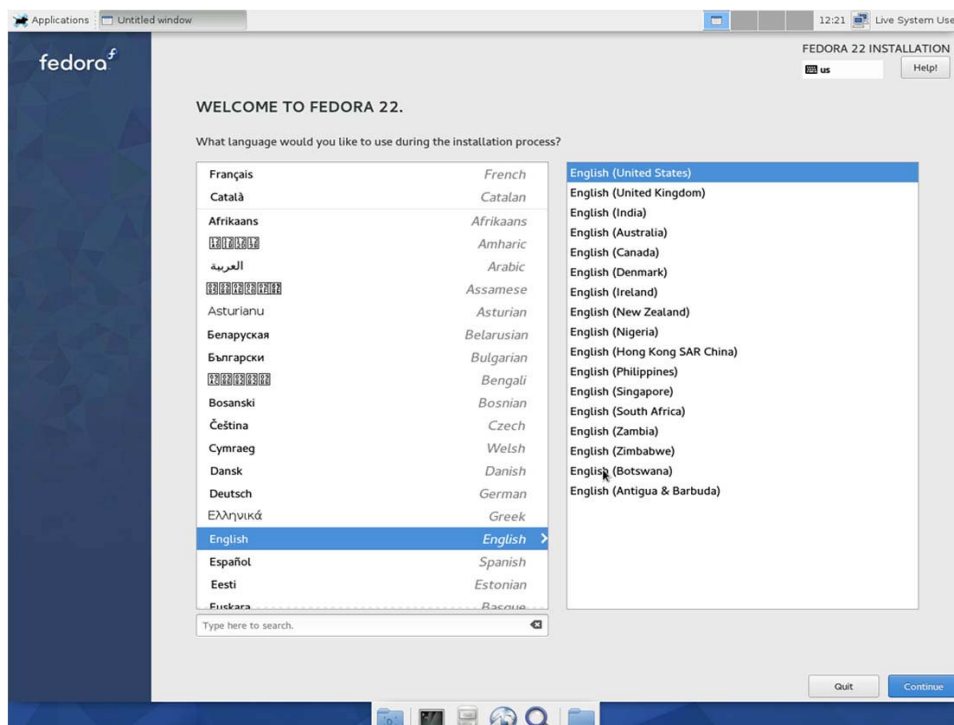

Select the appropriate language then click on “Continue”

In the following page select the “Installation Destination”

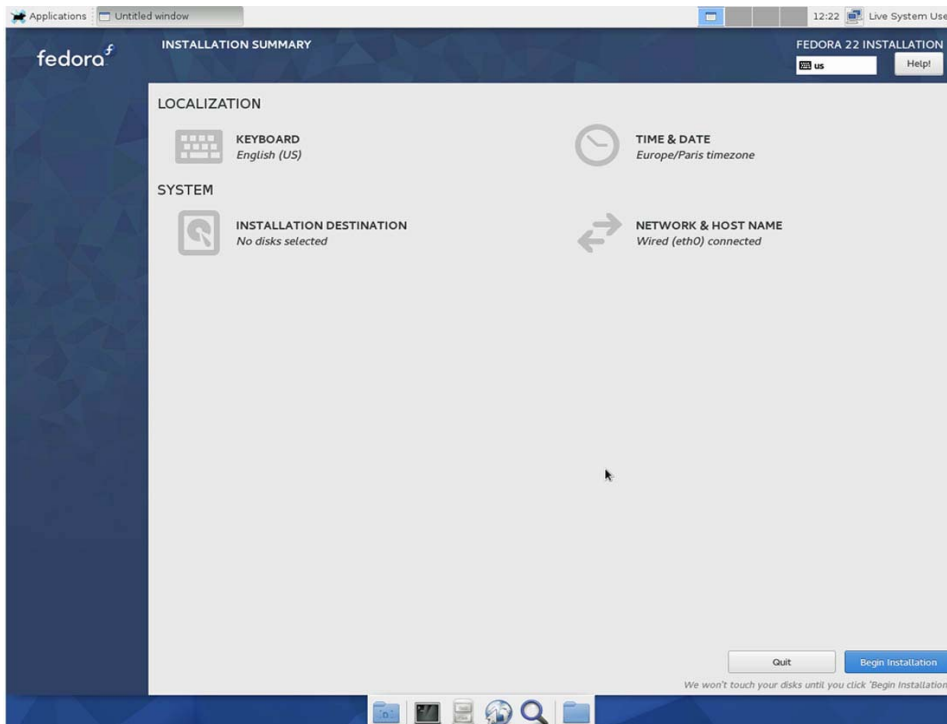

Then Select the Drive for installation (“MMC” in our example), partitioning option is “I will configure partitioning”, then validate with “Done” button

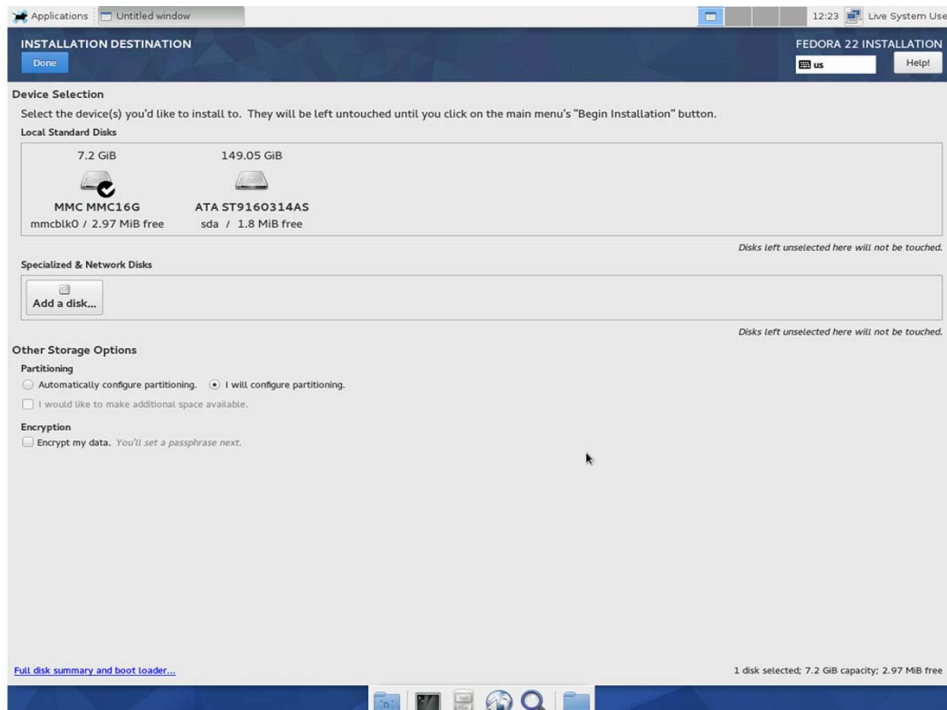

The partitioning scheme summary is displayed :

Select “Standard Partition” as partitioning scheme, then click on “Click here to create them automatically”

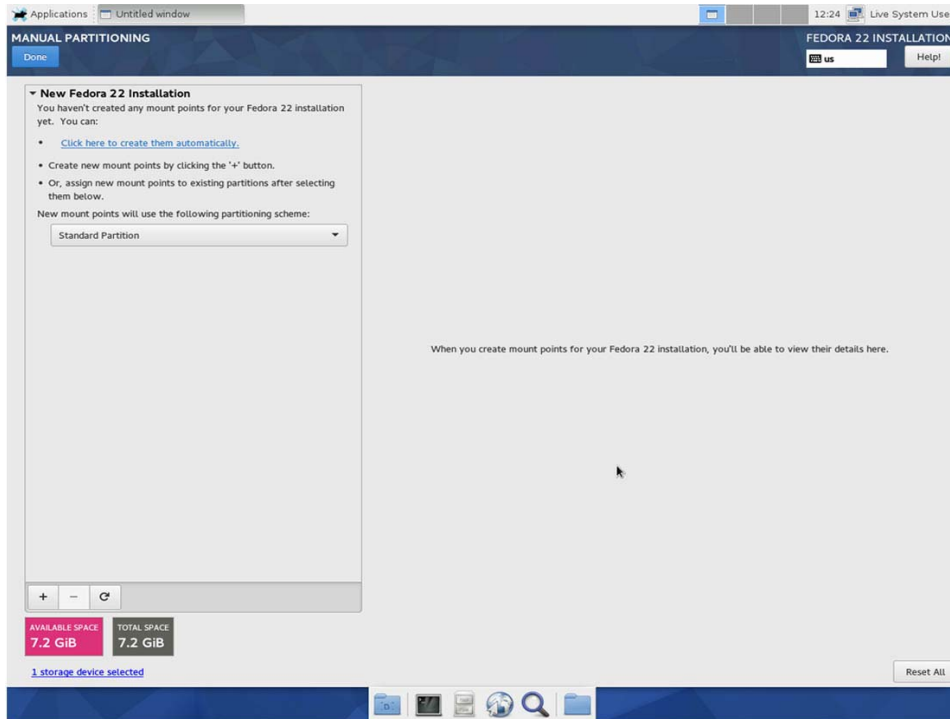

The details of partitioning are displayed

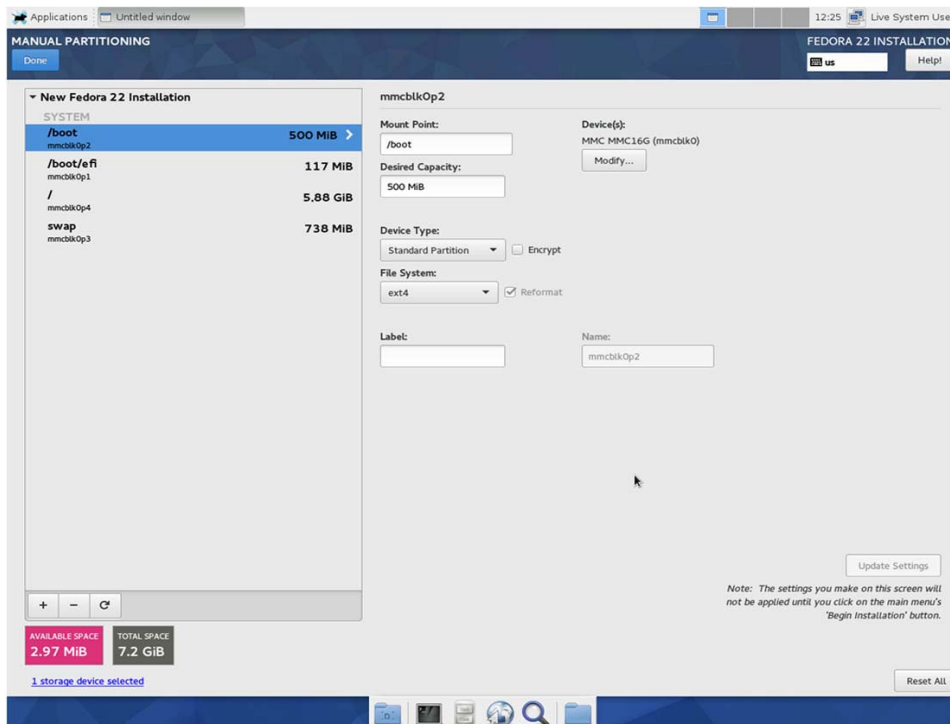

Click on “Done” for agreement.

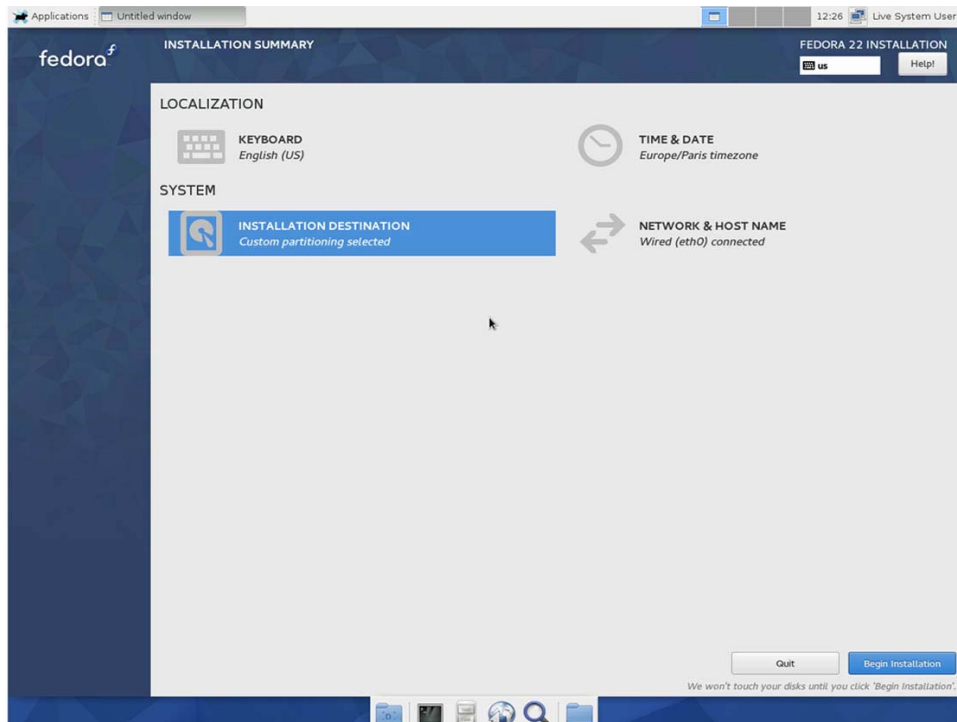

Click on “Begin Installation” to proceed.

During Hard Drive installation, root password and user account can be configured

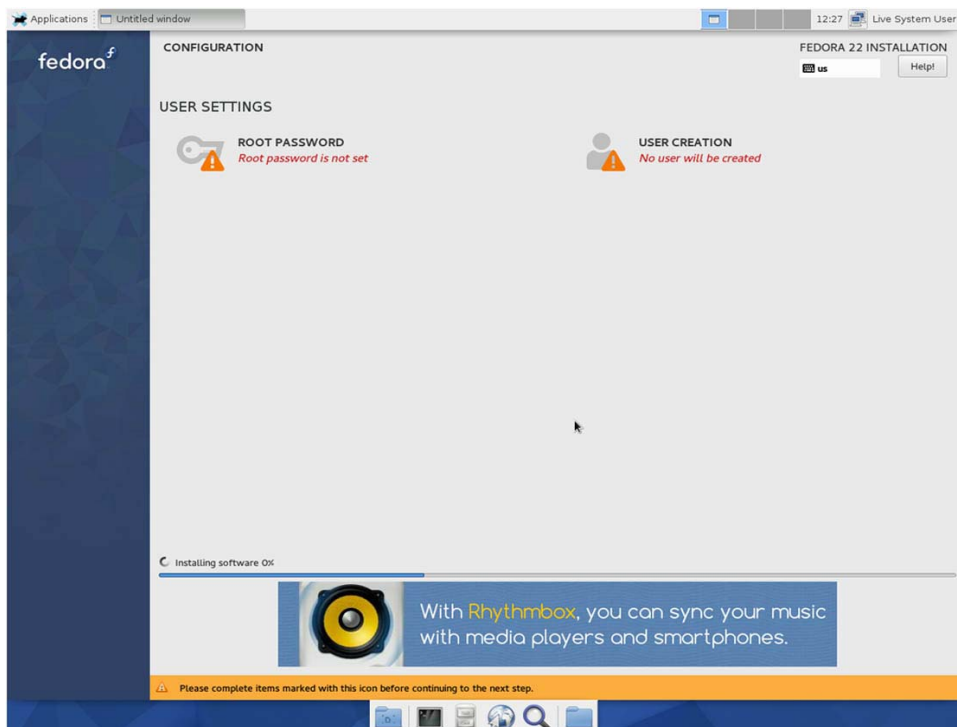

(Advertisement at the bottom of the page is provided by Fedora, not Kontron ...)

First the root password : ...

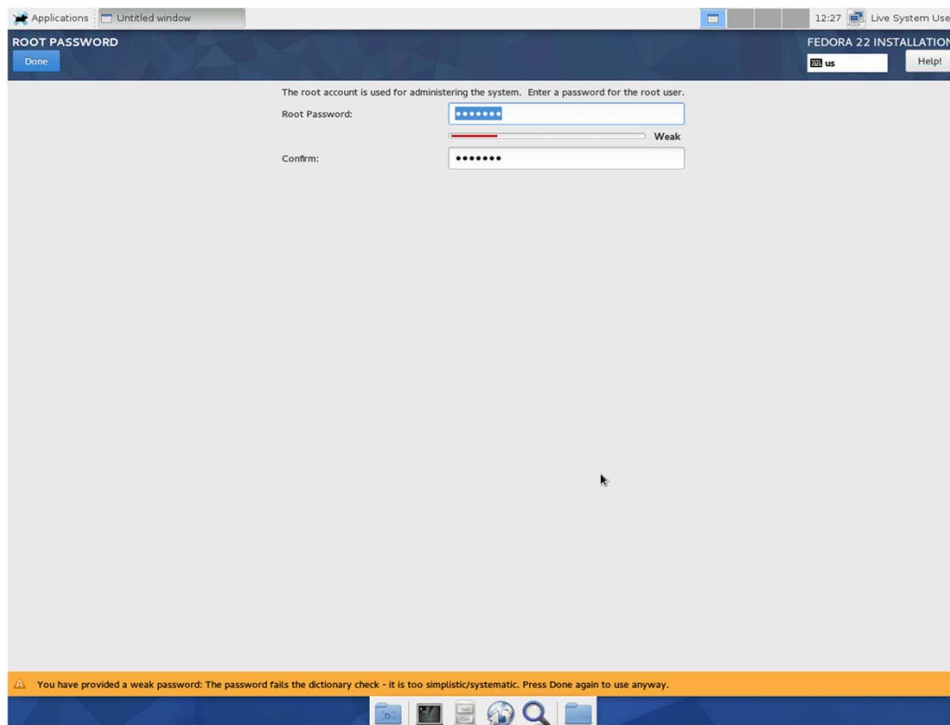

Click on "Done" to accept

Then a user account:

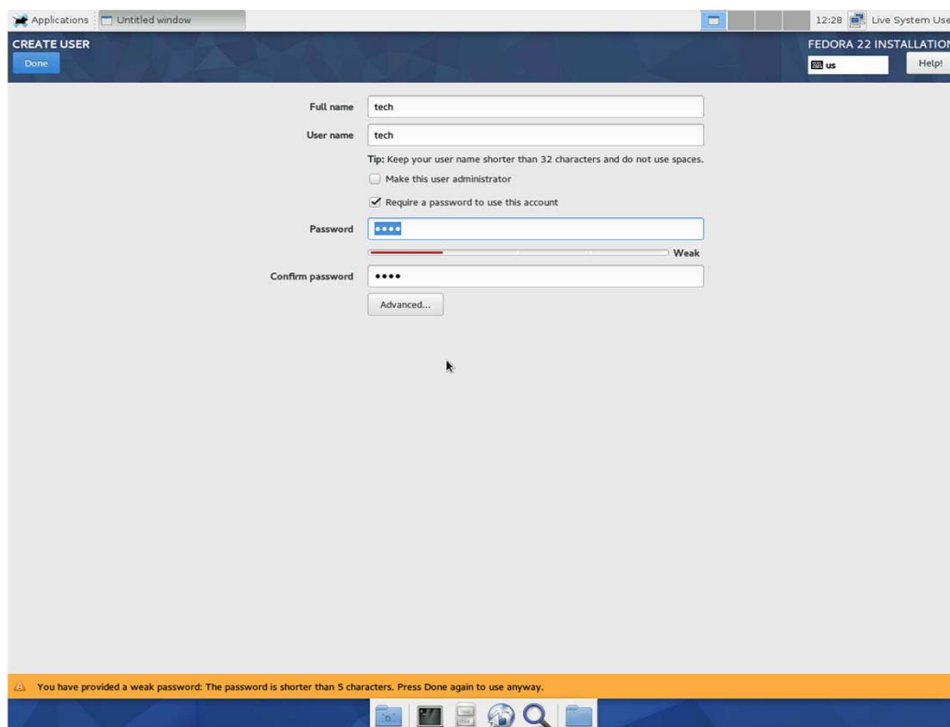

Click on "Done" to accept choice.

When the installation process has completed the following screen is displayed.

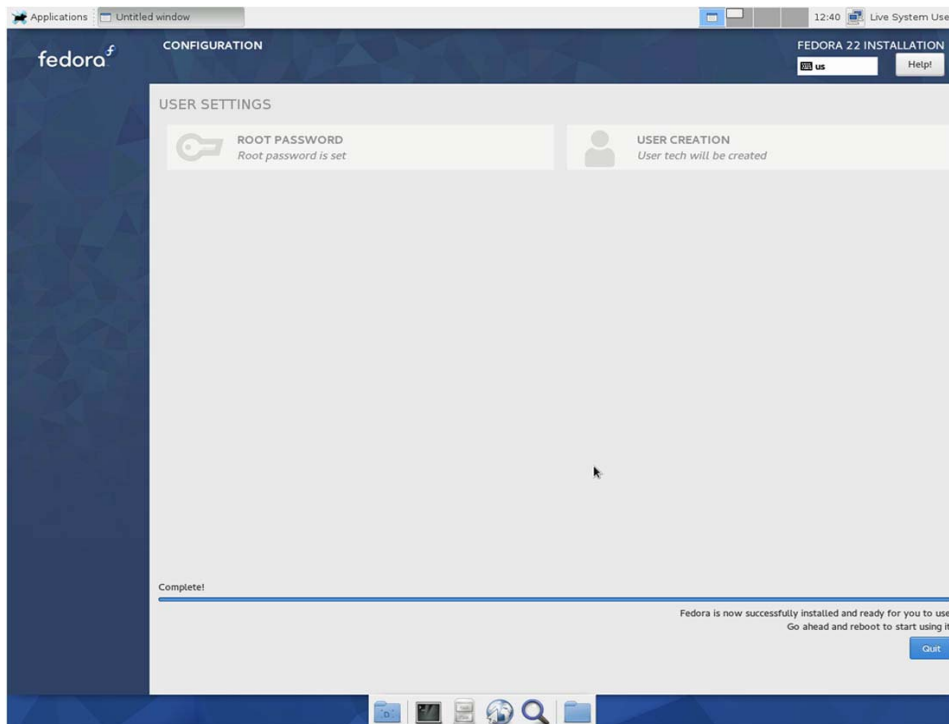

Click on "Quit" to end program and you can safely reboot the machine.



In some cases, the following Error message can appear:

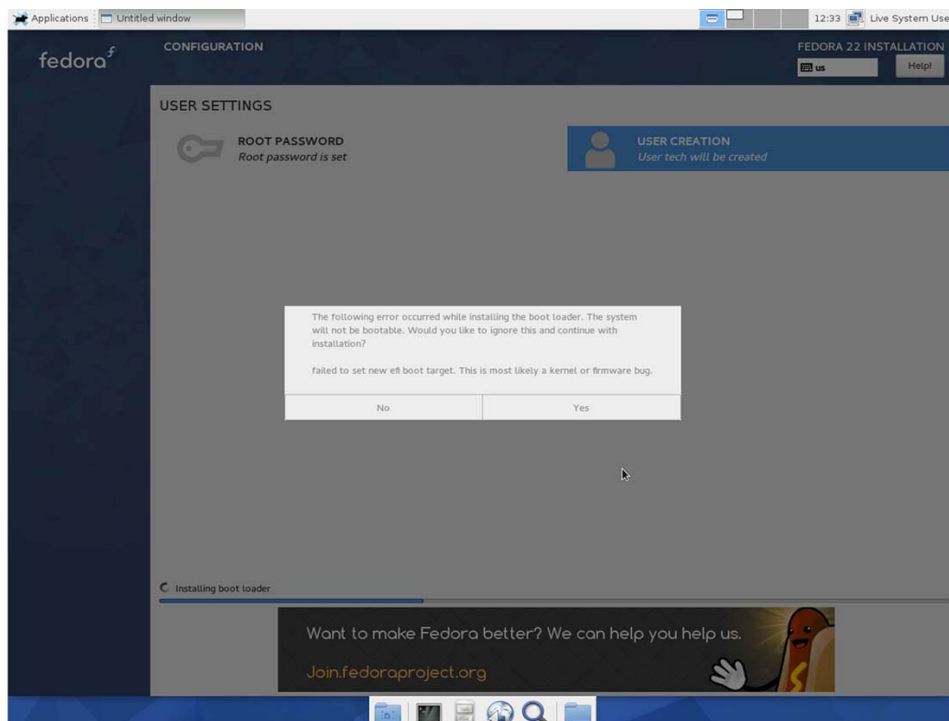

Click on "Yes" to continue with Installation. The system will not be impacted. This issue is currently under investigation.

2.11.5 Network Configuration

Network configuration is done with NetworkManager service.

Port Name	Linux Name	IP address
LAN A	Eth2	Not configured
LAN B	Eth0	Not configured
LAN C	Eth1	Not configured

2.12 Windows

Microsoft Windows 7 64-bit Board Support Package (BSP) is supported on TRACe-TR family. The BSP is referenced WIN7_64_BSP_TRACe_R01.00_ID15188.zip and can be download at <http://www.kontron.com/products/systems/vehicle-computers/trace-railway-computers/>

TRACE BSP only provides basic drivers/tools for any TRACe platform, specific drivers (Wi-Fi, LTE, MVB,... used for example in TRACe G,V,M variants) must be installed separately afterwards. Please refer to TRACe-TR Family User's Manual for more details".

2.12.1 Windows 7 Installation



Windows 7 necessitates a minimum of 17 GB disk for being used. Windows 7 can be installed on a 2.5" SSD SATA disk. eMMC device is not supported by Microsoft under Windows 7.

Before installing Windows OS please refer to TRACe-TR Family User's Manual for Windows and BIOS SETUP consideration.

2.12.2 Driver and BSP Installation

Refer to TRACe-TR Family User's Manual for detailed drivers version information. The drivers must be installed in standard Windows method. Chipset driver is recommended to be installed first.

- ▶ Chipset (for Atom™ Intel)
- ▶ Ethernet (For i210 Intel)
- ▶ HD Graphics (Intel)
- ▶ IO (Intel for Atom E3800 GPIO support)
- ▶ Serial port (Exar XR17V354 Pcie UART for COM-B COM-C)
- ▶ USB (Intel for USB 3.0 support)
- ▶ KEAPI (Kontron Generic BSP tools, libraries and drivers for TRACe COM Express board)
- ▶ TRACe (Kontron TRACe BSP tools and support around carrier board, CPLD ...)

When drivers are in a zipped format it must first be extracted before installation.

Exar Serial driver necessitates a specific installation method. Follow `install.txt` in "Serial port" directory for this.

For KEAPI and TRACe Kontron driver the Windows 7 KB3033929 update must be installed on the system (Windows6.1-KB3033929-x64.msu). Otherwise a signature problem will appears and the drivers will not be operational.

2.12.3 KEAPI

Kontron Embedded API is a software library that enables programmers to easily create their applications for monitoring and control hardware resources of Kontron boards, modules, systems and platforms. KEAPI is written in C language and distributed as a dynamic-linked library so it can be used by arbitrary application developed in C, C++ or higher programming languages simply by linking to the project.

KEAPI specification has been established so that it will allow fast and easy application migration between Kontron product. Most Kontron Computers provide this standardized API interface.

KEAPI library provides a set of functions for:

- ▶ Obtaining basic information about the system,
- ▶ CPU performance control,
- ▶ Temperature and voltage sensors monitoring,

- ▶ Monitoring and control of fans,
- ▶ Display backlight control,
- ▶ Access to EEPROM user storage area,
- ▶ I2C and SMBus communication,
- ▶ GPIO control,
- ▶ Watchdog.

All KEAPI functions can be called remotely from another computer over network (TCP/IP). KEAPI is compatible with PICMG EAPI specification (https://www.picmg.org/wp-content/uploads/COM_EAPI_R1_0.pdf). This means that it implements all functions defined by this specification. However, these functions offer just a small part of KEAPI functionalities and don't allow remote connection. Kontron EAPI is a layer between Kontron hardware and user application. KEAPI functions either use hardware drivers and operating system calls to perform requested operation on local board, or connects to KEAPI server that is installed on remote board somewhere on the internet. The KEAPI server application listens on a predefined port (default is 7890) and waits for incoming request. When the request comes, it uses KEAPI library to perform the operation and sends result back to the client.

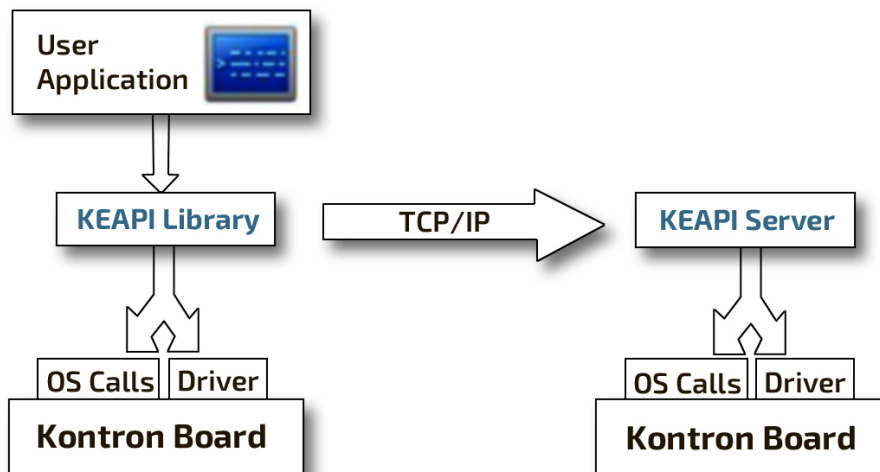

Figure 28: Kontron EAPI Architecture

KEAPI remote access service (KRS) and KEAPI graphical management (project DMCM for Device Monitoring and Control Monitoring) necessitate specific software. Contact your Kontron representative for more information.

2.12.4 BSP Tool

Any tool is delivered with its source code to allow an easy adaptation. Refer to TRACe-TR Family User's Manual for tool details.

2.12.5 Other Windows versions

Windows 7 BSP in 32 bits can be available on demand.

Windows 8 and Windows 7/8 Embedded in 32 or 64 bits are available for the TRACe COM Express board through the customer section on Kontron COME-mBT10 webpage:

<http://www.kontron.com/products/computeronmodules/com-express/com-express-mini/come-mbt10/emd>

The Windows BSP taken from COM Express module instead of the TRACe-TR Family are limited to support the following features:

- ▶ Chipset
- ▶ Ethernet
- ▶ Graphic
- ▶ USB 3.0
- ▶ Atom IO driver for GPIO, I2C, SPI, HS-UART, SD2
- ▶ SATA
- ▶ Audio Controller Intel® High Definition Audio
- ▶ TPM (TXE driver)

and some Kontron adapted drivers for:

- ▶ 4 GPI and 4 GPO
- ▶ SM BUS
- ▶ Watchdog (reset, interrupt or timer mode)
- ▶ NCT7802 HW Monitor for Voltage (3V3, VBAT, 12V, 5V)
- ▶ EEPROM R/W
- ▶ I2C
- ▶ BootCounter
- ▶ BoardInformation
- ▶ SPI
- ▶ Temperatures CPU-Temp and SYS-Temp

Compared to the Windows 7 full TRACe BSP delivery the following features are not supported by the COM Express BSP for TRACe-TR:

- ▶ Alarm Management IRQ10 event
- ▶ LM73 * 3 temperature sensors
- ▶ Carrier CPLD i2C bus and EEPROM
- ▶ TRACe product VPD
- ▶ Specific CPLD access for Board Controlling (the services available with the command `trace_config`)
- ▶ COM B and COM C or driver for XR17V354 Pcie UART but driver is available on www.exar.com

Generic Multifunction driver

Follow the procedure below:

1. Run ICE.
2. In Distribution Share window choose "Select Distribution Share..." and browse to DS (or DSSP1) folder, for example: *C:\Program Files\Windows Embedded Standard 7\DS*
3. Click file->open answer file and browse to one of WES7 templates (Application Compatibility, Thin Client, etc.).
Default location is *C:\Program Files\Windows Embedded Standard 7\DS\Templates\IBW*
4. In Distribution Share window browse Packages->Driver->Multifunction and double-click on Generic Multifunction driver to add it to your template answer file.
5. Click Validate->Validate Only and resolve all dependencies in Messages window (if needed).
6. Click Tools->Create Media->Create IBW Image From Answer File.. to create IBW image.
7. Copy IBW image to bootable flash and deploy it to target.

Appendix A - Associated Documentation

The following documentation is available on the Kontron web site.

- > TRACe B304-TR User's Manual SD.DT.G45
- > TRACe B304-TR Customization / Integration Guide SD.DT.G46
- > Datasheet TRACe B304-TR TRACe-B304-TR#...MB
- > Datasheet TRACe G304-TR TRACe-G304-TR#...MB
- > Datasheet TRACe M304-TR TRACe-M304-TR#...MB
- > Datasheet TRACe V304-TR TRACe-V304-TR#...MB

Appendix B - List of Abbreviations

AC	Alternating Current
BSP	Board Support Package
BSS	Basic Software Suite
CLI	Command Line Interface
COMe	COM Express®
CPLD	Complex Programmable Logic Device
CPU	Central Processing Unit
DC	Direct Current
DP	DisplayPort
ESD	Electrostatic Sensitive Device
GND	Ground
HMI	Human Machine Interface
HMU	Health Management Unit
LAN	Local Area Network
LED	Light Emitting Diode
OS	Operating System
PCI	Peripheral Component Interconnect
RTOS	Real Time Operating System
S3	Suspend to RAM
S4	Suspend to Disk
S5	Soft Power-Off
SATA	Serial Advanced Technology Attachment
SIM	Subscriber Identity Module
USB	Universal Serial Bus
WEEE	Waste Electrical and Electronics Equipment

MAILING ADDRESS

Kontron Modular Computers S.A.S.
150 rue Marcelin Berthelot - BP 244
ZI TOULON EST
83078 TOULON CEDEX - France

TELEPHONE AND E-MAIL

+33 (0) 4 98 16 34 00
Sales: Order-ATD-Toulon@Kontron.com
Support: GSS-ATD-Toulon@Kontron.com

For further information about other Kontron products, please visit our Internet web site:
www.kontron.com.