







→ **Big screen view from
an ultra short distance**



-  **60" image from a distance of only 73cm**
-  **Shadow-free images on interactive whiteboards**
-  **Superior brightness – 2500 ANSI Lumens**
-  **8W speaker – all-in-one multimedia setup**
-  **Enhanced security features**
-  **Whisper quiet – only 28dB**
-  **No maintenance – filter free design**

EX525ST
Digital DLP® Projector

Extreme Short Projection

The pinnacle of image excellence; the EX525ST gives big screen projection from very short distances. Installed or portable the EX525ST integrates 8W audio and extensive connectivity in an all-in-one design. At 2500 ANSI Lumens, this native XGA projector is easy to use and allows for projection without shadows for the best business and education presentations.

SHORT THROW LENS

Project powerful images from virtually any location; the EX525ST can project an impressive 60-inch diagonal image from just 73cm from the screen. Stand-alone or ceiling mounted the EX525ST eliminates shadows on the screen and allows you to present with ease.

Current Projectors

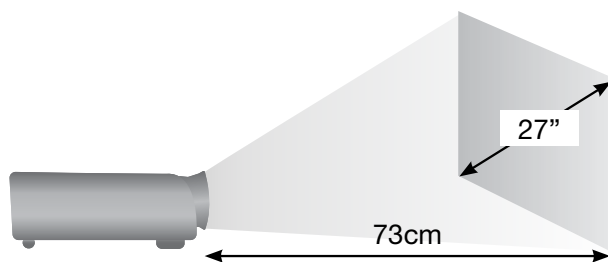
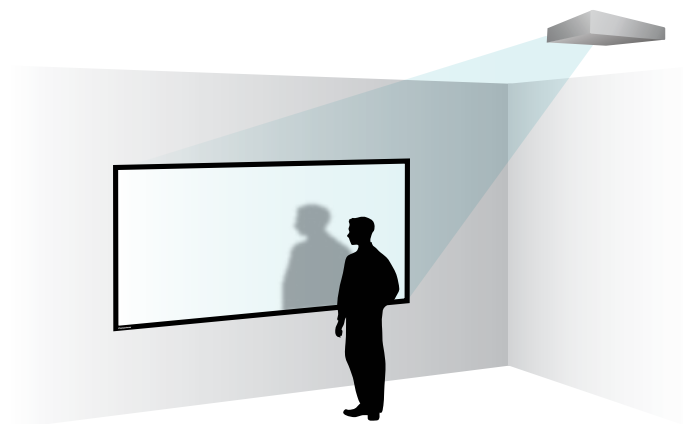

Without Short Throw

EX525ST – Shadow-free Images

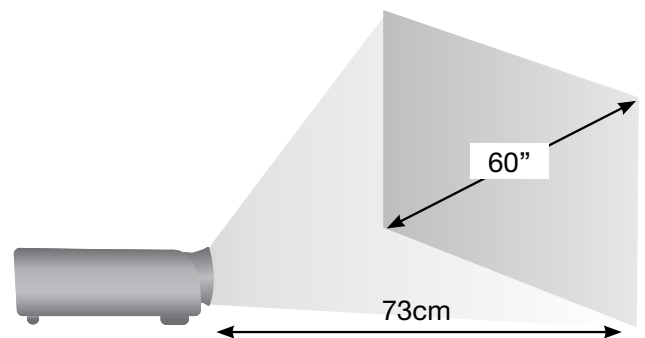
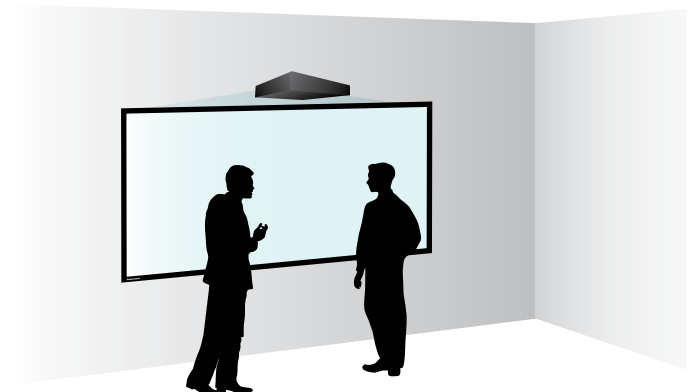

With Short Throw

EXTENSIVE CONNECTIVITY

The EX525ST can accept a wide variety of computer and video input signals including: DVI, VGA, SCART, Component, S-Video, Composite, RS232 and RJ45.

Network Monitoring and Control

For remote control and access from a web browser, manage and monitor the projectors over a LAN network via RJ45.

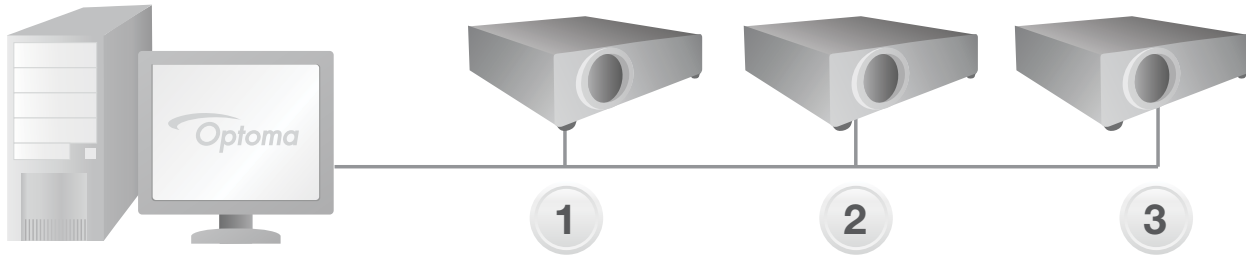

AMAZING COLOURS

BrilliantColor™ technology enables higher brightness levels by boosting mid-tone colours, resulting in more vibrant, precisely accurate colours projected on the screen.



COLOUR PERFORMANCE GUARANTEE

Optoma guarantees colour quality will stay as new for 5 years*

We are so confident that the EX525ST colours will not fade that we guarantee the colours will remain vibrant and vivid, even after many years of use.





IMAGE PERFORMANCE GUARANTEE

Optoma guarantees image quality will remain as new for 5 years**

To retain image clarity Optoma projectors are designed with DLP® technology, preventing degradation over time and consistent pixel performance. The Imager Guarantee ensures a precise picture performance for a minimum of 5 years.



BrilliantColor™	
WITH 2500:1 contrast ratio	WITHOUT 500:1 contrast ratio
	
<p>BrilliantColor™ Advanced colour processing for bright, vivid, lifelike colour.</p> <p><small>*Simulated Images</small></p>	

MAINTENANCE FREE

DLP® technology ensures lower cost of ownership, longer life and improved reliability compared to other technologies such as LCD. The filter free projector design - no more regular filter cleaning or replacements, saving you time and money.



POWERFUL BUILT-IN 8W SPEAKERS

All-in-one, portable, built-in audio speakers



ULTRA-SHORT THROW LENS

Only a small distance is required between the projector and the screen.

HOOK IT UP TO ALMOST ANYTHING!

The EX525ST is easy to use with most of your home entertainment and gaming devices. Simply connect, power up and project for the ultimate big screen viewing experience.

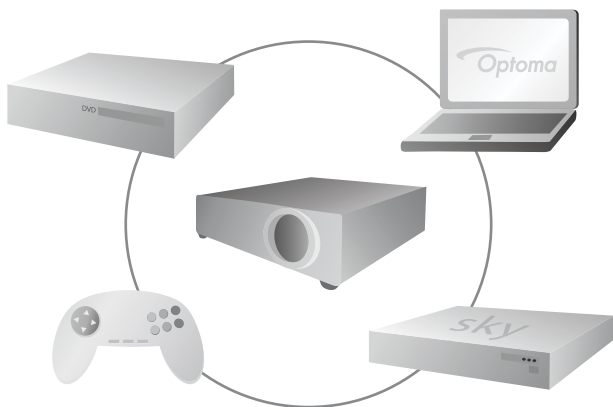

PORTABLE OR INSTALLED

Small enough to be portable from room to room or perfectly suited for installation with interactive whiteboards.



IMPROVED SECURITY

With the inclusion of a tough security bar, Kensington lock, Key pad lock and password protection.

SAVING TIME AND ENERGY

It takes less than 15 seconds for the projector to power up and shutdown, so the EX525ST not only saves time but energy too. Timer Control function turns the projector off when it is unused, saving energy and extending the lamp life of the projector to an astonishing 4000 hours***.

Auto Power Off

If after a pre-determined time the projector does not receive a signal, it will turn itself off, conserving power and extending the life of the lamp.

Fast Switch On

Display an image on screen quickly after switching the projector on.

Low Power Standby Mode

Reduces energy consumption.

EASY TO USE

Quiet Operation

The EX525ST features Optoma's whisper-quiet design, highly-effective in reducing audible noise levels to 28dB.

Preset Modes

The EX525ST is ideal for much more than presentations. Six modes including a blackboard mode for the classroom, provide instant optimised settings for different applications.

Specifications

	EX525ST	
Native Resolution	XGA 1024 x 768	
Compressed Resolution	SXGA (1280 x 1024)	
Brightness - BRIGHT mode	2500 ANSI Lumens	
Brightness - STD mode	1500 ANSI Lumens	
Contrast	2500:1	
Noise Level	28dB	
Lamp Life***	4000/3000 (STD/BRIGHT mode)	
Projection Lens	F Number	2.59
	Focus Length	6.97mm @ 0.73m
	Focus/Zoom Type	Manual Focus / 2.0x Digital Zoom
	Throw Ratio	0.6:1 (Projection Distance:Image Width)
Projection Distance	0.5 - 3.7m	
Image Size	1.04m - 7.72m (41.05" - 303.75") Diagonal 4:3	
Display Technology	Single 0.55" XGA type X DMD chip DLP® Technology by Texas Instruments	
Weight / Dimensions (W x D x H)	4.3 kg / 339 x 276 x 122mm	
Remote Control	Full function remote with mouse control and direct source selecting	
INPUTS	DVI-I (HDCP), Digital RGB (HDMI via adaptor)	
	15 Pin D-Sub VGA (SCART & Component via adaptor)	
	S-Video 4 Pin Mini Din	
	Composite RCA	
	Audio Mini Jack - Audio computer inputs	
	2 x Stereo RCA - Audio video inputs	
	USB (remote mouse)	
CONTROL	RJ45	
	RS232 - 3 Pin Mini DIN	
OUTPUT	15 Pin D-Sub VGA (monitor loop-through)	
	Audio Mini Jack	
Audio	8W Speaker	
Aspect Ratio	4:3 Native, 16:9 Compatible	
Keystone Correction	± 20 Degrees Vertical	
On Screen Display	18 Languages: English, German, French, Italian, Spanish, Portuguese, Polish, Dutch, Russian, Finnish, Swedish, Greek, Norwegian, Danish, Hungarian, Czech, Turkish and Arabic	
Video Compatibility	PAL SECAM 576i/p, NTSC 480i/p, HD 720p/1080i	
Uniformity	85%	
Displayable Colours	16.7 Million	
Horizontal Scan Rate	91kHz	
Vertical Scan Rate	56Hz	
Power Supply	100 - 240V, 50 - 60Hz	
Power Consumption	280W Maximum, Standby mode < 5W (< 1W Optional)	
Operating Conditions	Operating: 5 - 35°C, 85% Humidity (Max), 3000m Altitude (Max)	
Security	Security bar, Kensington Lock Port, Password Protection	
Standard Accessories	Lens Cover, AC Power Cord, VGA Cable, USB Cable, Full Function Remote, Batteries x 2, Quick Start Guide, CD User Manual, Warranty Card, WEEE Card	
RoHS	Compliant	
Lamp Warranty	6 months or 1000 hours – whichever comes sooner	
Warranty	Warranty may vary by country. Please see www.optomaeurope.com or ask your local supplier for details	
Colour Guarantee*	5 Years	
Imager Guarantee**	5 Years	

Easy to use remote control



Remote Control

- 1 Remote Mouse
- 2 Vertical Keystone Correction
- 3 Volume Control
- 4 Brightness Adjustment
- 5 AV Mute
- 6 Direct Input Source Selection

Connections

- 7 VGA Loop-through
- 8 VGA - SCART & Component via adaptor
- 9 DVI-I - HDMI & 2nd VGA via adaptor
- 10 S-Video
- 11 Composite Video
- 12 RS232
- 13 USB (remote mouse)
- 14 RJ45
- 15 Audio In (DVI-I & VGA)
- 16 Audio In L&R (S-Video & Composite)
- 17 Audio Out
- 18 Security bar
- 19 Kensington™ Lock

Exceptional Connectivity/Multiple Terminals

Digital and analogue connectivity including; DVI-I, VGA, RS232, RJ45, VGA Out and 2 x Audio In.



Projection Distance 0.5 - 3.7m (4:3 Aspect Ratio)

Diagonal Image Size (inch)	Projection Distance (m)	Horizontal Image Size (m)	Vertical Image Size (m)	Diagonal Image Size (m)	Image Offset (m)
55	0.67	1.12	0.84	1.40	0.13
60	0.73	1.22	0.91	1.52	0.14
70	0.85	1.42	1.07	1.77	0.16
80	0.98	1.63	1.23	2.04	0.18
90	1.10	1.83	1.38	2.29	0.21
100	1.22	2.03	1.53	2.54	0.23
120	1.46	2.43	1.83	3.04	0.27
304	3.70	6.17	4.64	7.72	0.70

For guide purposes only

EX525ST is capable of 16:9 aspect ratio projection. When projecting a 16:9 image the image sizes, screen height and offset information will differ from the above.

Optoma Europe Ltd.
42 Caxton Way, Watford Business Park, Watford, Hertfordshire, UK. WD18 8QZ
www.optoma.co.uk

Panoview
Optoma recommended screens
www.panoview.eu



*Optoma guarantees that in normal use, Optoma DLP® colour quality will be indistinguishable from when new. Please note that worn lamps will give slight variance. Exclusions: (1) Guarantee is voided if the projector is subject to damage through mis-use. (2) Guarantee may be void in industrial or commercial entertainment environments where dust or smoke is particularly excessive (3) Guarantee will not apply if lamp brightness is below 50% due to wear or if the projector is not working due to other fault. **Optoma guarantees that in normal use, the DLP® imager guarantee will retain quality for at least 5 years providing consistent pixel performance. Exclusions: (1) Guarantee is voided if the projector is subject to damage through mis-use. (2) Guarantee may be void in industrial or commercial entertainment environments where dust or smoke is particularly excessive. ***Typical lamp life achieved through testing. Will vary according to operational use and environment conditions. Copyright © 2008, Optoma Europe Ltd. All other product names and company names used herein are for identifications purposes only and may be trademarks or registered trademarks of their respective owners. Errors and omissions excepted, all specifications are subject to change without notice. DLP®, BrilliantColor™ and the DLP logo are registered trademarks of Texas Instruments.