

Chromalox®

Installation, Operation and RENEWAL PARTS IDENTIFICATION

SERVICE REFERENCE

DIVISION 4		SECTION NWH
SALES REFERENCE	(Supersedes PE424)	PE424-1
		161-058005-001
DATE	APRIL, 1999	

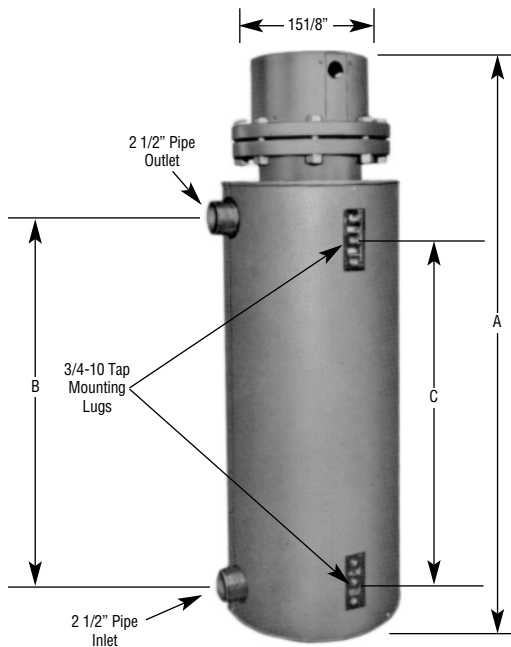

Type NWH-18 Circulation Heater for Water Heating (150 Pound Construction)

Specifications — Table A

Model	Volts	Phase	kW	W/in ²	Dimensions (In.)		
					A	B	C
NWH-185015	240 or 480	3	50	42	45 ⁷ / ₈	24 ¹ / ₁₆	21 ³ / ₁₆
NWH-187515	240 or 480	3	75	45	53 ⁷ / ₈	32 ¹ / ₁₆	29 ³ / ₁₆
NWH-1810015	240 or 480	3	100	49	60 ⁷ / ₈	39 ¹ / ₁₆	36 ³ / ₁₆
NWH-1812515	240 or 480	3	125	50	68 ¹ / ₂	47 ⁹ / ₁₆	43 ³ / ₁₆
NWH-1815015	240 or 480	3	150	50	78	56 ¹³ / ₁₆	53 ⁵ / ₁₆
NWH-1817515	240 or 480	3	175	50	87	65 ¹³ / ₁₆	62 ⁵ / ₁₆
NWH-1820015	240 or 480	3	200	50	97	75 ¹³ / ₁₆	72 ⁵ / ₁₆

GENERAL

WARNING: This heater is not intended for use in hazardous atmospheres where flammable vapors, gases, liquids or other combustible atmospheres are present as defined in the National Electrical Code. Failure to comply can result in explosion or fire.

The NWH-18 series is a general-purpose water or water-based solution circulation heater intended for use indoors. It is designed for 150 psig at 550°F per ANSI standards.

The 18 copper-sheathed tubular elements are centered in a 8" diameter galvanized steel heating chamber and welded to a removable galvanized steel flange. The assembly is surrounded by 3" insulation and sheet metal jacket.

Depending upon the order specifications, the NWH-18 may or may not be factory equipped with an AR or other Chromalox thermostat. Such thermostats function to control outlet temperatures and to limit internal temperatures under abnormal flow conditions. These controls do not fail-safe.

WARNING: Users should install adequate back-up controls and safety devices with their electric heating equipment. Where the consequences of failure may be severe, back-up controls are essential. Although the safety of the installation is the responsibility of the user, Chromalox will be glad to make equipment recommendations.

INSTALLATION

WARNING: Hazard of Shock. Disconnect all power before installing heater.

1. Vertical Mounting (Preferred) —

When the heater is vertically mounted, the terminal housing will be at the top of the heater. The water inlet pipe will be located on the side near the bottom of the heater and the outlet pipe at the top.

The axis of the chamber will be in a vertical position as in the photo above and as in Figure A.

Note: A drain pipe located at the bottom of the heater should be provided and enough room left, when mounting heater, to allow draining the heater.

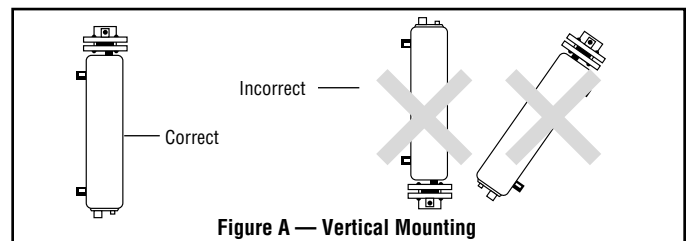

Figure A — Vertical Mounting

INSTALLATION

2. Horizontal Mounting (Optional)

When mounting heater horizontally, inlet and outlet pipes **must** be up. In any other position, heater cannot be purged of air, and elements may be seriously damaged. (See Figure B)

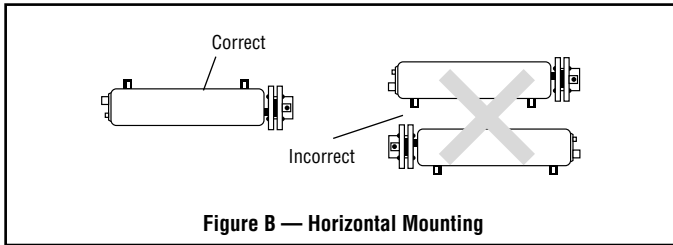

Figure B — Horizontal Mounting

3. Whether vertically or horizontally, the heater should be rigidly mounted so that vibration is at a minimum since excessive vibration will result in erratic thermostat operation. The NWH-18 is provided with mounting lugs to support the heating chamber. (See photo on previous page)
4. By using a slotted mounting assembly on either of the mounting lugs, the heater chamber will be permitted to expand with increasing temperature.
5. **DANGER: Hazard of Fire.** Provide minimum of 6" spacing from chamber and related piping to nearest combustible material. Avoid operation of heater near combustible fluids or in combustible vapor or gas laden atmospheres.
6. Provide adequate space at terminal to end permit withdrawal of the heater from chamber for servicing.

WIRING

WARNING: Hazard of Shock. Any installation involving electric heaters must be effectively grounded in accordance with the National Electrical Code to eliminate shock hazard.

1. Be sure line voltage matches heater voltage (on nameplate).
2. Electric wiring to heater must be installed in accordance with local and National Electrical Codes by a qualified person as defined in the NEC.
3. Power controllers *must* be used when heaters are rated for 480 volt service or if the amperage rating of the heaters exceeds the contact rating of the thermostat.
4. Refer to Wiring Diagram Table B for the proper wiring diagram for connecting heater.

Table B — Wiring Diagrams

Heater Model	240V 3 Phase Fig.	480V 3 Phase Fig.
NWH-185015	1	2
NWH-187515	1	2
NWH-1810015	1	2
NWH-1812515	1	2
NWH-1815015	1	2
NWH-1817515	1	2
NWH-1820015	1	2

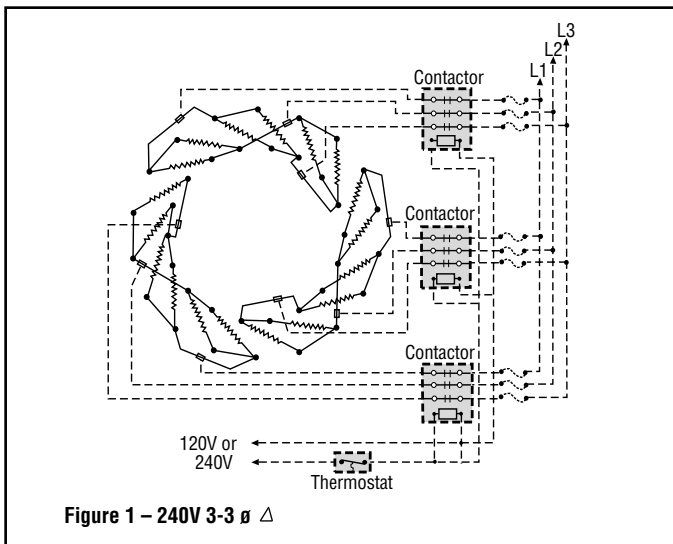

Figure 1 — 240V 3-3 φ Δ

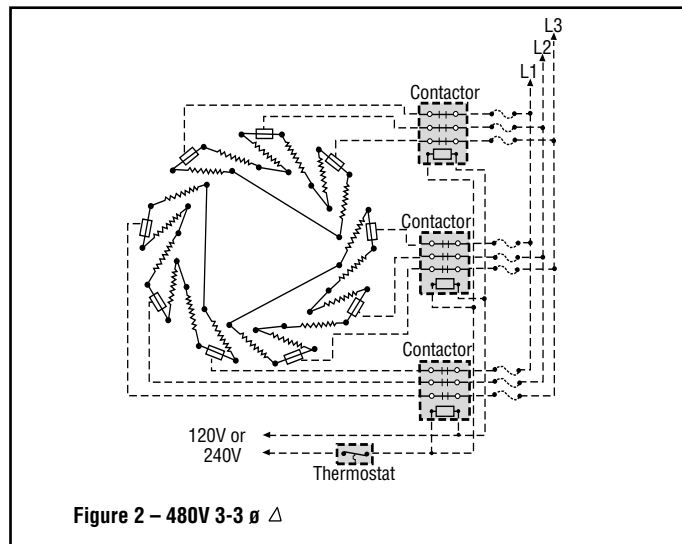

Figure 2 — 480V 3-3 φ Δ

Note: Dotted lines indicate "customer furnished." However, Thermostat can be furnished by Chromalox if so specified on the order.

OPERATION

1. Do not heat solutions that are corrosive to the heating element sheath or the heating chamber.

WARNING: Type NWH Circulation Heaters are equipped with copper heating elements and galvanized-steel heating chambers. It is the responsibility of the user to know the chemical composition of the corrosive solution and the character of the materials entering the solution as well as the corrosive effect of the solution upon the heating elements and chamber. Chromalox cannot warrant any electric circula-

tion heater against failure by sheath corrosion if such failure is the result of operating conditions beyond our control.

2. Terminal ends of heater must be protected from drippings, condensation, spray or direct spill-over of material. Their presence at the terminals may damage heater electrical insulation. Liquid-tight terminal enclosures are available to protect heater. Check Factory.
3. If foreign material is carried by the liquid flow, install suitable filters in the inlet pipe line to the heater.
4. Do not allow heater to operate when liquid flow is interrupted.

MAINTENANCE

1. **WARNING: Hazard of Shock. Disconnect all power before servicing heater.**
2. Remove heating element assembly periodically to check heater sheath for scaling, corrosion or excessive oxidation. Correct operating conditions to minimize sheath deterioration.
3. Periodically check temperature control and limit control operation to insure accurate and safe process operation.
4. Check all electrical connections periodically and retighten connections which may have loosened in service. Replace wire and wire terminals which show signs of oxidation which would interfere with establishment of reliable electrical connections.

RENEWAL PARTS IDENTIFICATION

Model	Volts	Phase	kW	Replacement Element Assembly
NWH-185015	240	3	50	155-013185-046
NWH-185015	480	3	50	155-013185-047
NWH-187515	240	3	75	155-013185-049
NWH-187515	480	3	75	155-013185-050
NWH-1810015	240	3	100	155-013185-052
NWH-1810015	480	3	100	155-013185-053
NWH-1812515	240	3	125	155-013185-058
NWH-1812515	480	3	125	155-013185-059
NWH-1815015	240	3	150	155-013185-061
NWH-1815015	480	3	150	155-013185-062
NWH-1817515	240	3	175	155-013185-064
NWH-1817515	480	3	175	155-013185-065
NWH-1820015	240	3	200	155-013185-067
NWH-1820015	480	3	200	155-013185-068

Parts Common To All Heaters	
Flexitallic Gasket	132-019779-007
Standard Gasket	132-017222-007

Note: When ordering parts for Model Numbers suffixed by "XX" or any other letter or letters not specifically identified on this instruction sheet, order Renewal Parts on special order basis, giving name of part, part number, model number and description.

Limited Warranty:
Please refer to the Chromalox limited warranty applicable to this product at
<http://www.chromalox.com/customer-service/policies/termsofsale.aspx>.

Chromalox[®]
PRECISION HEAT AND CONTROL

2150 N. RULON WHITE BLVD., OGDEN, UT 84404
Phone: 1-800-368-2493 www.chromalox.com