

MPC-3004

4-Axes Positioning Card

User's Manual (V1.6)

健昇科技股份有限公司

JS AUTOMATION CORP.

台北縣汐止市中興路 100 號 6 樓

6F,No.100,Chungshin Rd.

Shitsu, Taipei, Taiwan, R.O.C.

TEL : 886-2-2647-6936

FAX : 886-2-2647-6940

<http://www.automation.com.tw>

E-mail : control.cards@automation.com.tw

Correction record

Version	Record

Contents

1.	Forward.....	4
2.	Features.....	5
3.	Specifications.....	6
3.1	MPC-3004 Main card	6
3.2	ADP-3004ADIN Din rail mounted wiring board	7
4.	Layout and dimension.....	8
4.1	MPC-3004 Main card layout	8
4.2	MPC-3004 Main card dimension.....	8
4.3	ADP-3004ADIN Din rail mounted wiring board layout	9
4.4	ADP-3004ADIN Din rail mounted wiring board dimension.....	9
5.	Pin definitions	10
5.1	Connector front view	10
5.2	Pin definitions	10
6.	I/O Interface diagram.....	11
6.1	Input diagram.....	11
6.2	Output diagram	11
6.3	MPC-3004 Pulse driving method for single end input:	12
6.4	Pulse driving method for differential input:	12
7.	External wiring diagram	13
8.	Hardware settings	14
8.1	CARD ID Setting.....	14
8.2	Single/Dual pulse mode setting	14
9.	How to use dos demo program	15
9.1	DOS mode demo program	15
9.2	Window mode demo program	16
10.	Applications	18
11.	Ordering information	19

Notes on hardware installation

Please follow step by step as you are installing the control cards.

1. Be sure your system is power off.
2. Be sure your external power supply for the wiring board is power off.
3. Plug your control card in slot, and make sure the golden fingers are put in right contacts.
4. Fasten the screw to fix the card.
5. Connect the cable between the card and wiring board.
6. Connect the external power supply for the wiring board.
7. Recheck everything is OK before system power on.
8. External power on.

Congratulation! You have it.

For more detail of step by step installation guide, please refer the file “installation.pdf “ on the CD come with the product or register as a member of our user’s club at:

<http://automation.com.tw/>

to download the complementary documents.

1. Forward

MPC3004 is a PCI bus point to point 4 axes motion control card, which is DSP based design with the FPGA technology developed by JS Automation Corp.

Owing to the high performance of DSP we call this card “Intelligent card”, MPC3004 consumes less CPU resource and gives a better performance than other dummy cards.

The practical application consideration makes this card easy to use and easy to wire, the security function also provides the system integrator a protection of illegal copy of firmware.

other motion control card:

MPC-2042 2 axes linear/circular/point to point (standard function) motion control card (ISA bus)

MPC-3024 4 axes linear/circular/point to point (standard function) motion control card (PCI bus)

MPC-3034 4 axes linear/circular/point to point (advanced function) motion control card (PCI bus)

MPC-3028 8 axes linear/circular/point to point (advanced function) motion control card (PCI bus)

MPC-3042 2 axes linear/circular/point to point (standard function) motion control card (PCI bus)

MPC-3035 4 axes linear/circular/point to point (standard function) with advanced encoder counter function / with 2 8bit DA's motion control card (PCI bus)

MPC-3035L 4 axes linear/circular/point to point (standard function) with advanced encoder counter function motion control card (PCI bus)

Any comment is welcome,

please visit our website: www.automation.com.tw for the up to date informations.

2. Features

- 2.1 PCI plug and play function with card ID for 16 identical cards
- 2.2 4-axis servo/stepping motor control, each axis work independently
- 2.3 2-4 axes linear interpolation
- 2.4 High pulse rate and excellent accuracy of acceleration
- 2.5 Software limit switch blocks safe area (space)
- 2.6 Scale ratio formula for real distance programming
- 2.7 Backlash compensation
- 2.8 8 isolated D/I and 8 isolated D/O channels
- 2.9 Single or dual-pulse mode selectable by hardware
- 2.10 Supports DIN rail mounted wiring board
- 2.11 Software key function

3. Specifications

3.1 MPC-3004 Main card

- 3.1.1 Input photo-coupler isolation voltage — 2500Vac 1Min
- 3.1.2 Data width — 32 Bits
- 3.1.3 Control axes — 4
- 3.1.4 Card ID — 4 bits
- 3.1.5 Specific input — 3 (LS+, LS-, Home) per axis with photo-coupler
- 3.1.6 General input — 8 with photo-coupler
- 3.1.7 General output — 8 with photo-coupler and relay contact “a”
- 3.1.8 Maximum length setting — 24 Bits (e.g. 16, 777, 215 unit length)
- 3.1.9 Arithmetic calculation — 32 Bits
- 3.1.10 Max. speed of driving pulse — 1MHz
- 3.1.11 Max. acceleration rate — 4MHz/sec
- 3.1.12 Frequency deviation — $\pm 0.005\%$ of driving pulse
- 3.1.13 Max. working distance — 32 Bits (e.g. $\pm 2,147,483,647$ unit length)
- 3.1.14 Timer setting range — 0-60,000ms circulating
- 3.1.15 I/O connector — mini SCSI female 50 pins between wiring boards
- 3.1.16 Connector type — plugable connector
- 3.1.17 External supply — DC 24V \pm 4V
- 3.1.18 Operation temp — 0 to 70° C
- 3.1.19 Operation humidity — RH5~95%, non-condensing
- 3.1.20 Dimension — 180(W)*115(H)mm, 7.09(W)*4.53(H)in

3.2 ADP-3004ADIN Din rail mounted wiring board

- 3.2.1 External supply — DC 24V±4V
- 3.2.2 On board build-in s.p.s. — DC+5V 500mA (max)
- 3.2.3 Operation temp — 0 to 70° C
- 3.2.4 General input LED — 8
- 3.2.5 General output — 8 power MOS (1A 120V DC) with LED
- 3.2.6 Specific I/O LED — 20
- 3.2.7 Specific servo control connector — 4 D-type 9 pin connector
- 3.2.8 Operation humidity — RH5~95%, non-condensing
- 3.2.9 Dimension — 86(W) * 204(L) *47(H)mm, 3.39(W) * 8.03(L) *1.85(H)in

4. Layout and dimension

4.1 MPC-3004 Main card layout

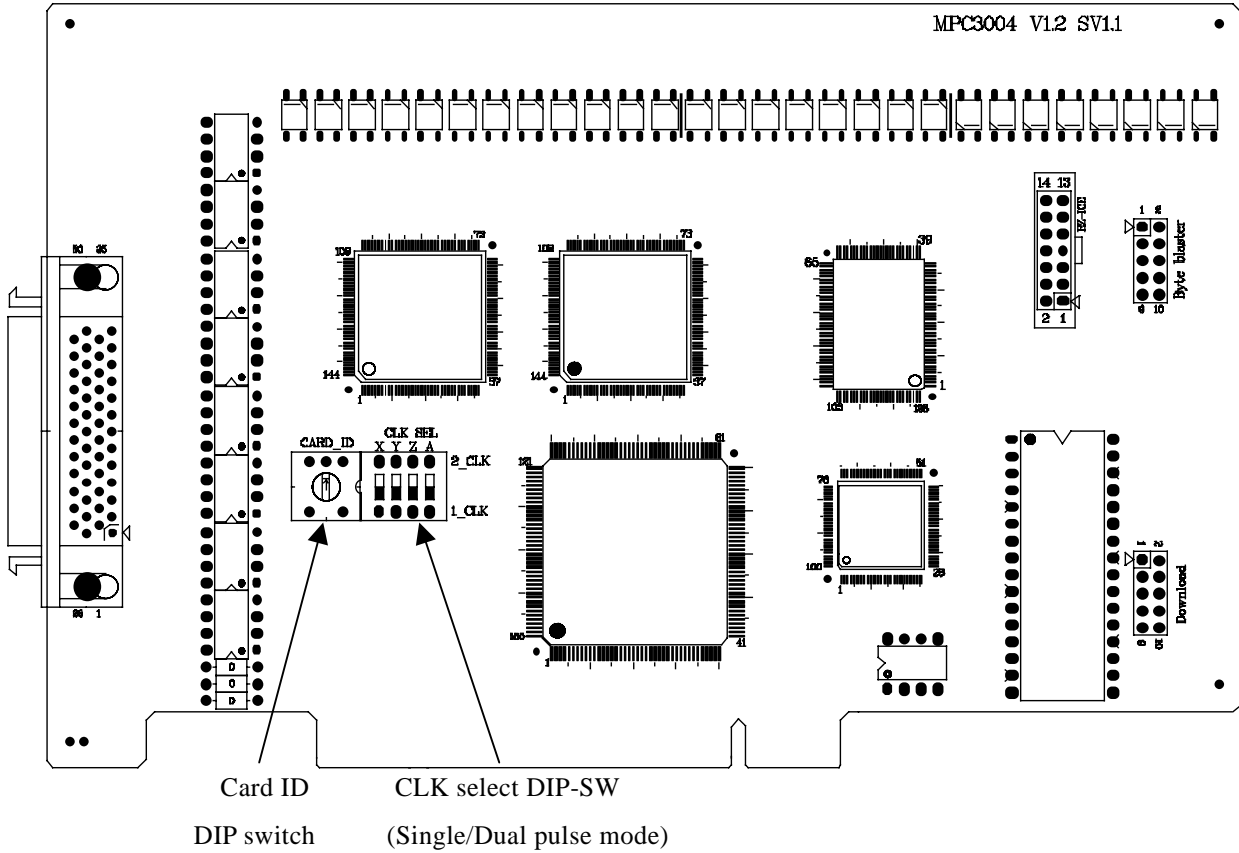

4.2 MPC-3004 Main card dimension

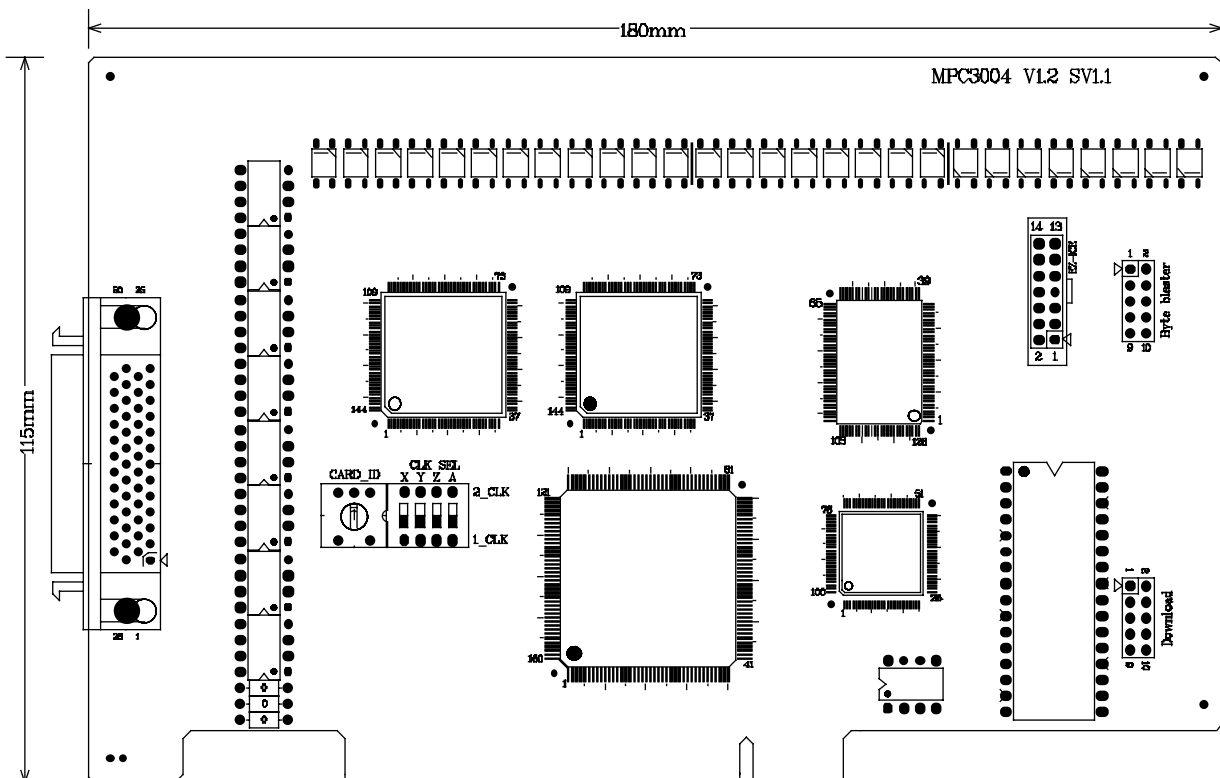

4.3 ADP-3004ADIN Din rail mounted wiring board layout

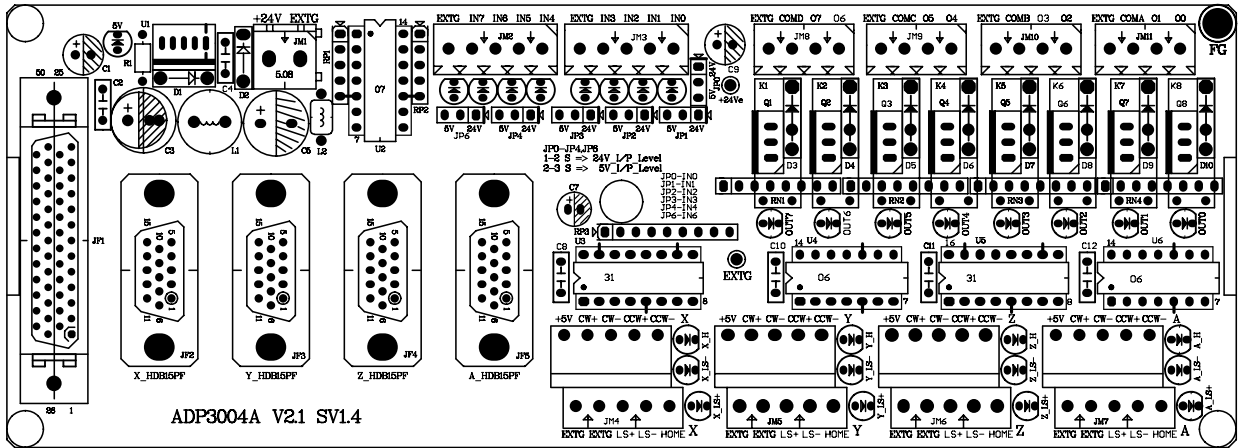

4.4 ADP-3004ADIN Din rail mounted wiring board dimension

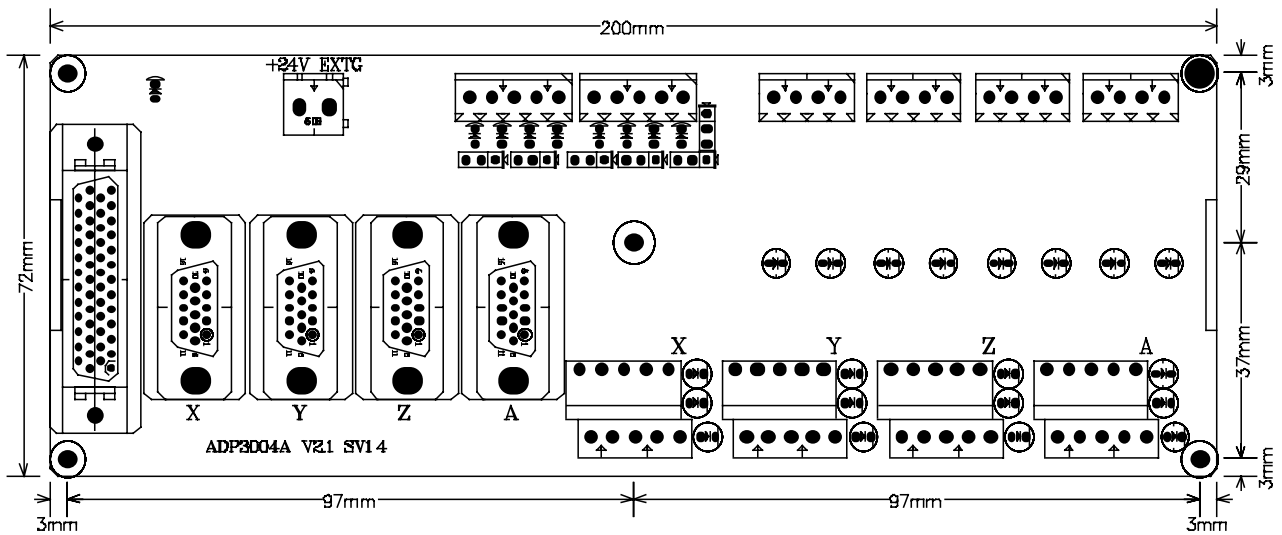

5. Pin definitions

5.1 Connector front view

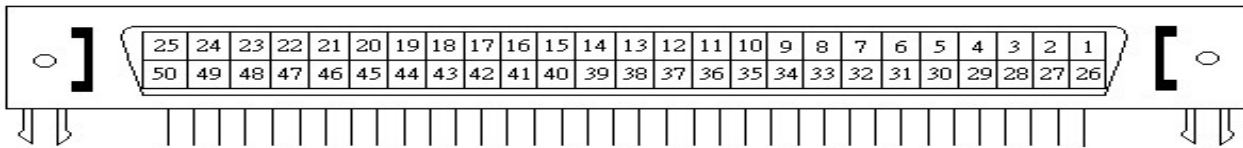

5.2 Pin definitions

Pin No.	Descriptions	Pin No.	Descriptions
1	+24V (External supplied DC/24V power input)	26	EXTG (common terminal for +24V , +5V, I/P , O/P)
2	+24V (External supplied DC/24V power input)	27	EXTG (common terminal for +24V , +5V, I/P , O/P)
3	+5V (DC/5V output,regulated from external 24V input)	28	EXTG (common terminal for +24V , +5V, I/P , O/P)
4	+5V (DC/5V output,regulated from external 24V input)	29	EXTG (common terminal for +24V , +5V, I/P , O/P)
5	X_CW (CLOCK) : CW for dual pulse mode , CLOCK for single pulse mode	30	Z_CW (CLOCK) : CW for dual pulse mode , CLOCK for single pulse mode
6	Y_CW (CLOCK) : CW for dual pulse mode , CLOCK for single pulse mode	31	A_CW (CLOCK) : CW for dual pulse mode , CLOCK for single pulse mode
7	X_CCW (DIR) : CCW for dual pulse mode , DIRECTION for single pulse mode	32	Z_CCW (DIR) : CCW for dual pulse mode , DIRECTION for single pulse mode
8	Y_CCW (DIR) : CCW for dual pulse mode , DIRECTION for single pulse mode	33	A_CCW (DIR) : CCW for dual pulse mode , DIRECTION for single pulse mode
9	X_LS+ : Positive over-travel limit switch input for X axis	34	Z_LS+ : Positive over-travel limit switch input for Z axis .
10	Y_LS+ : Positive over-travel limit switch input for Y axis	35	A_LS+ : Positive over-travel limit switch input for A axis .
11	X_LS- : Negative over-travel limit switch input for X axis	36	Z_LS- : Negative over-travel limit switch input for Z axis .
12	Y_LS- : Negative over-travel limit switch input for Y axis	37	A_LS- : Negative over-travel limit switch input for A axis .
13	X_H : Home limit switch input for X axis	38	Z_H : Home limit switch input for Z axis .
14	Y_H : Home limit switch input for Y axis	39	A_H : Home limit switch input for A axis .
15	EXTG (common terminal for +24V , +5V, I/P , O/P)	40	EXTG (common terminal for +24V , +5V, I/P , O/P)
16	EXTG (common terminal for +24V , +5V, I/P , O/P)	41	EXTG (common terminal for +24V , +5V, I/P , O/P)
17	EXTG (common terminal for +24V , +5V, I/P , O/P)	42	EXTG (common terminal for +24V , +5V, I/P , O/P)
18	IN0 : General purpose input0	43	OUT0 : General purpose output .
19	IN1 : General purpose input1	44	OUT1 : General purpose output .
20	IN2 : General purpose input2	45	OUT2 : General purpose output .
21	IN3 : General purpose input3	46	OUT3 : General purpose output .
22	IN4 : General purpose input4	47	OUT4 : General purpose output .
23	IN5 : General purpose input5	48	OUT5 : General purpose output .
24	IN6 : General purpose input6	49	OUT6 : General purpose output .
25	IN7 : General purpose input7	50	OUT7 : General purpose output .

6. I/O Interface diagram

6.1 Input diagram

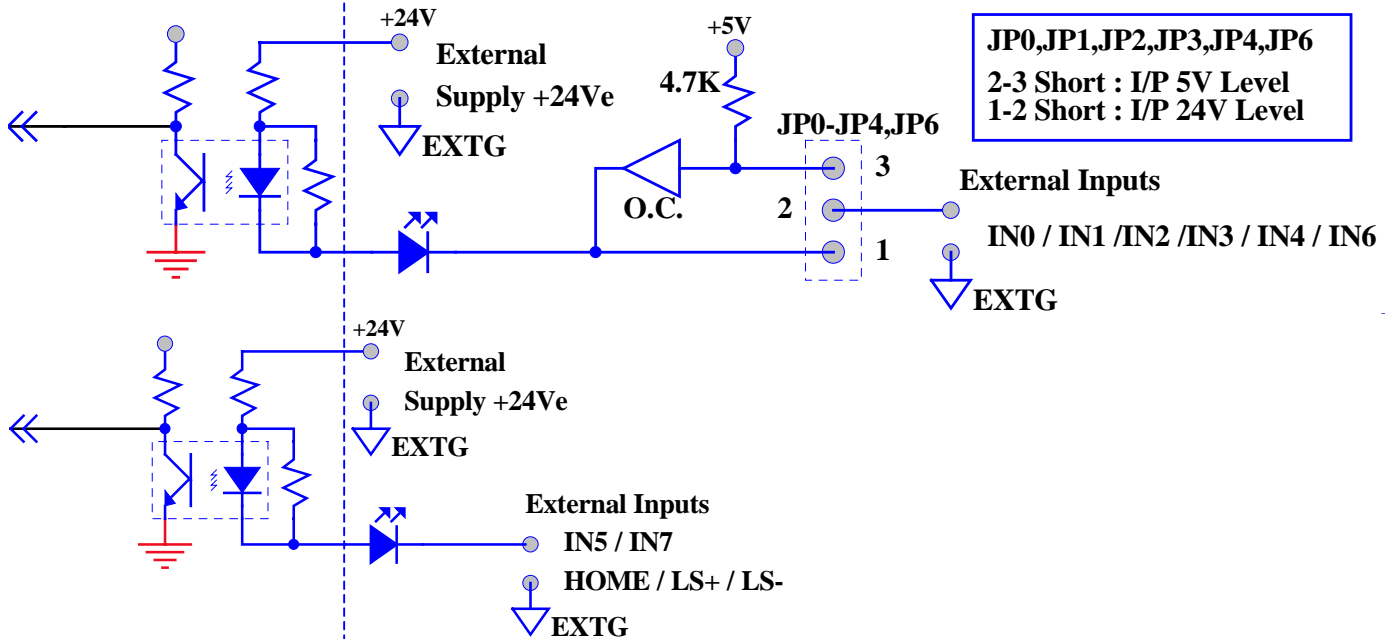

6.2 Output diagram

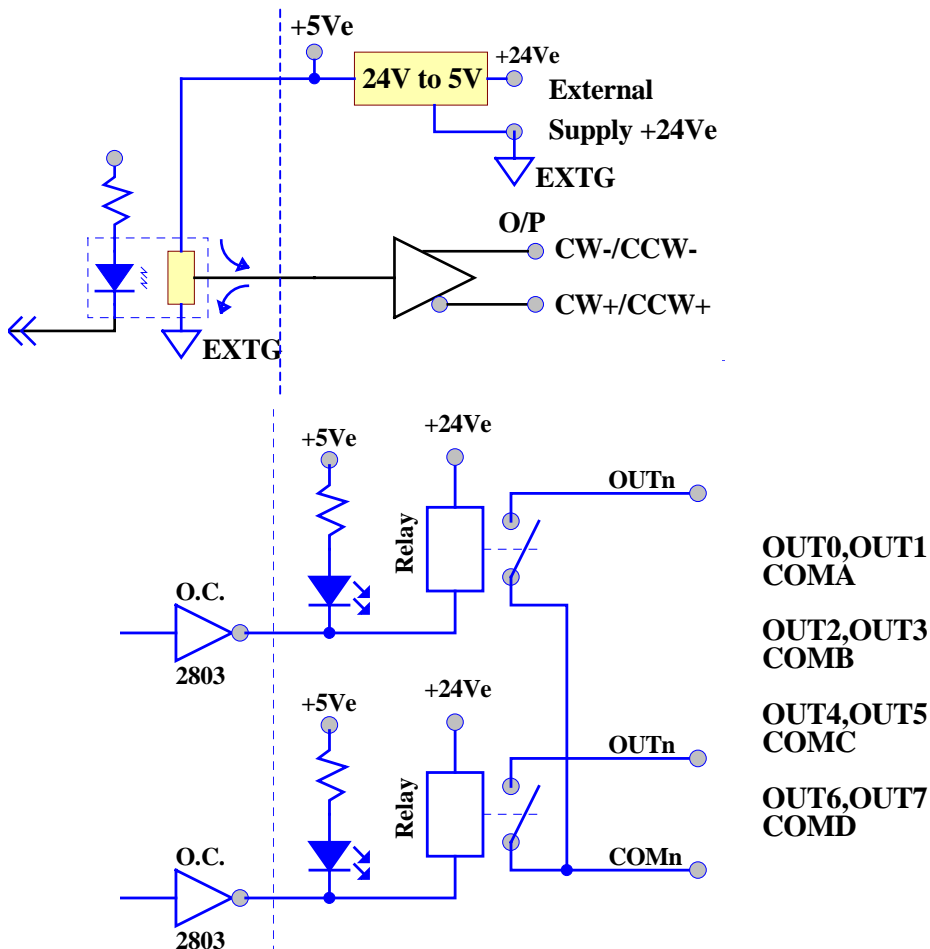

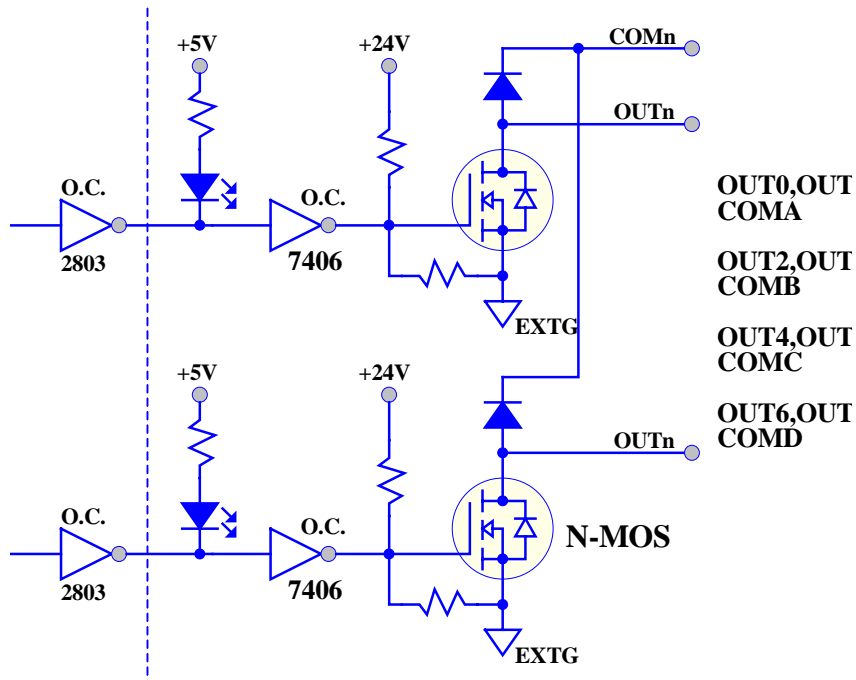

6.3 MPC-3004 Pulse driving method for single end input:

<< Active Lo >>

<< Active Hi >>

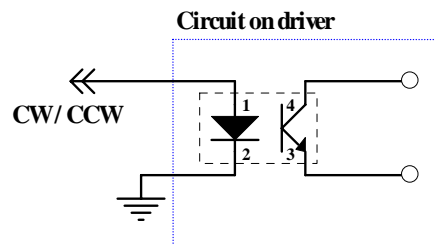
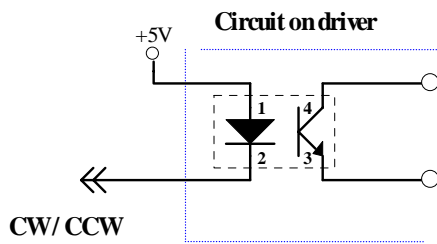

6.4 Pulse driving method for differential input:

If your driver's differential input has pull up resistor as the right diagram, direct connection to cw+/ccw+ is acceptable otherwise external resistor connect as right diagram is required.

The recommended value for R1~R3 is 4.7K Ohm.

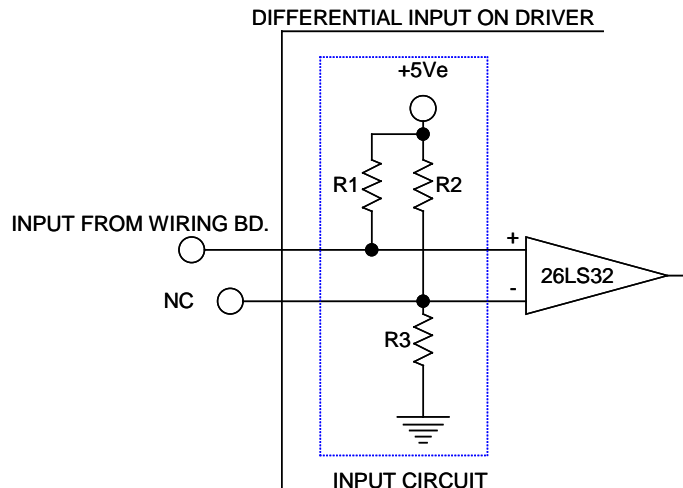

7. External wiring diagram

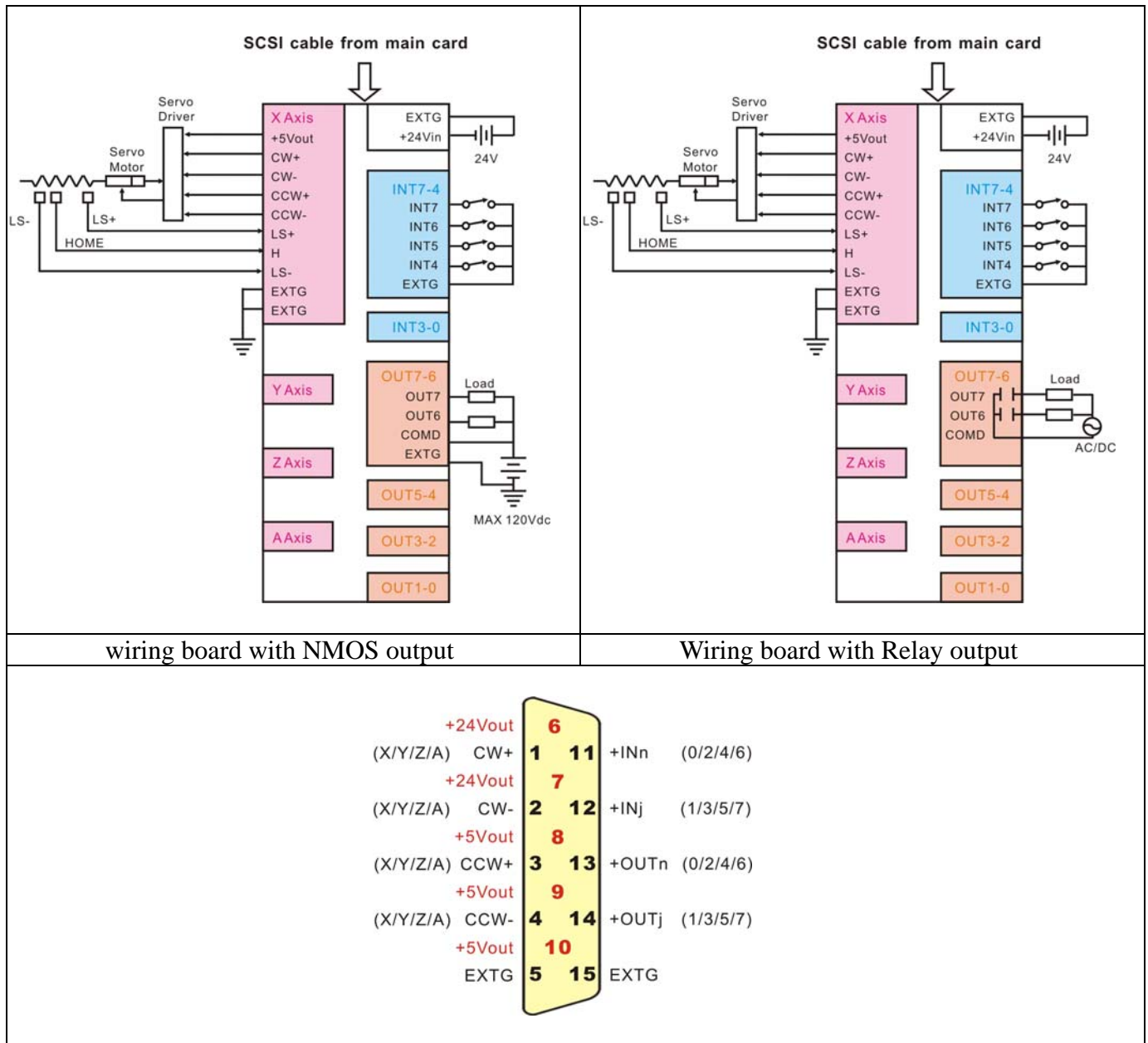

8. Hardware settings

8.1 CARD ID Setting

Since PCI cards have plug and play function, the card ID is required for programmer to identify which card he/she will control without knowing the physical address assigned by the Windows. A 4 bits DIP switch or rotary switch for distinguishing the 16 identical card.

The following example sets the card ID at 12.

DIP SW SETTING : (ID=12)

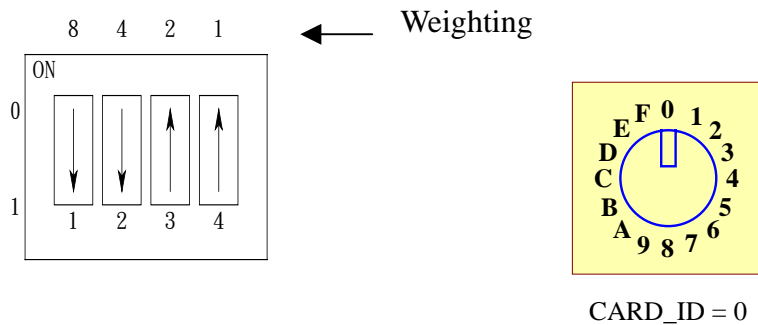

8.2 Single/Dual pulse mode setting

8.2.1 1_CLK(4DIP-SW) : Single/Dual pulse mode setting

Any bit set "on" means the corresponding axis in dual pulse mode ,otherwise single pulse mode.

The following example sets Y,A axes in Single pulse mode (CLOCK,DIRECTION)and both X&Z axes in Dual pulse mode (CW,CCW)

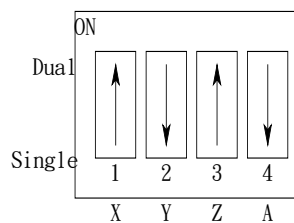

9. How to use dos demo program

9.1 DOS mode demo program

9.1.1 BEFORE USING THE DEMO PROGRAM

The demo program is provided to the user with the purpose of familiar the functions of MPC card. You should setup the driver and dll in windows to register the resources. Since the demo program is implemented in DOS environment, the card address should be get from “settings->control panel->system->device manager->MPC3004”.

9.1.2 START UP :

Execute the demo program MPC3004.exe and then key in the card address. If press “enter” without any card address data , the default address is 200H.

There are four blocks in the screen: motion control, speed adjustment, global i/o, security

```
***** MPC-2004 PULSE DISTRIBUTING CARD ***** Ver 1.0
-----[ MOTION CONTROL ]-----[ SPEED ADJUSTMENT ]-----
PORT NUMBER:.....7 6 5 4 3 2 1 0 [X]_MOVING START PULSE RATE.. 200
[Q]_SYSTEM LOGIC(INPL):0 0 0 1 1 1 1 1 [C]_MOVING MAX. PULSE RATE.. 2000
[LOGIC_DIR.6][HOME.2][LSN.1][LSP.0] [V]_MOVING ACC. PULSE RATE.. 1000
[T]_MOVING MODE..... H_DIR+ ABS [B]_HOMING START PULSE RATE.. 200
H_DIR- REL+ [N]_HOMING MAX. PULSE RATE.. 2000
H_RETN REL- [M]_HOMING ACC. PULSE RATE.. 1000
[F]_ENABLE ZERO..... Disable [S]_HOMING SLOW PULSE REAT.. 200
[K]_TARGET POSITION ..... 800 [A]_BACKLASH PULSE..... 0
_CURRENT POSITION ..... 0 [D]_LENTH/REV (mm/rev)..... 1
_ACTIVE STATUS..... 0X0017 [R]_MOTOR'S RESOLUTION(pulse) 1
-----[ GLOBAL I/O ]-----[ SECURITY ]-----
[F1]_RESET STATUS: VALUE: 5AA5 SECURITY MESSAGE(SEC_CMD) .... Ready
CLOCK.....10.272 SECURITY MODE ..... Enable
_PORT NUMBER.....7 6 5 4 3 2 1 0 SECURITY STATUS ..... Open
[W]_INPUT LOGIC :...1 1 1 1 1 1 1 1 [F2]CHANGE SECURITY CODE
[E]_OUTPUT LOGIC :...1 1 1 1 1 1 1 1 [F4]FIRST SET SECURITY CODE
INPUT PORT :...1 1 1 1 1 1 1 1 [F5]OPEN SECURITY CODE
[7-0]OUTPUT PORT :...0 0 0 0 0 0 0 0
-----[ COMMANDS ]-----
[P]_Position [L]_Load COPS [Z]_4 Axis [Esc]-Quit
[I]_HaltStop [O]_DecStop
SEGMENT:200 AXIS:X [ USER MODE ]
```

9.1.3 All the functions are “one stroke” command, you only press the key data as it is in the bracket [], you will get a prompt and follows its instruction everything is ok.

Note:

1. The power on default value of the polarity of over-travel limit switch is normally close.
2. If you has not connect the over-travel limit switch or connect it at normally open, be sure to change the polarity of the setting before running, else it will stop as if it is emergent stop by over-travel.

9.2 Window mode demo program

9.2.1 Power off

9.2.2 Hook MPC3004 card

9.2.3 Power on, and window finds new card

9.2.4 Please designate the driver to setup,

9.2.5 for example \\MPC3004\Software\Win98_2k_me\driver

9.2.6 Install the demo program and header file and example for development and testing.

9.2.7 for example: \\MPC3004\Software\Win98_2k_me\install\setup3004.exe

9.2.8 New application

9.2.9 The example and API files will be default at

9.2.10 C:\Program Files\Control Card\Mpc3004\

9.2.11 Reboot your system

9.2.12 Run Start -> Program -> Control Card -> Mpc3004 ->Mpc3004

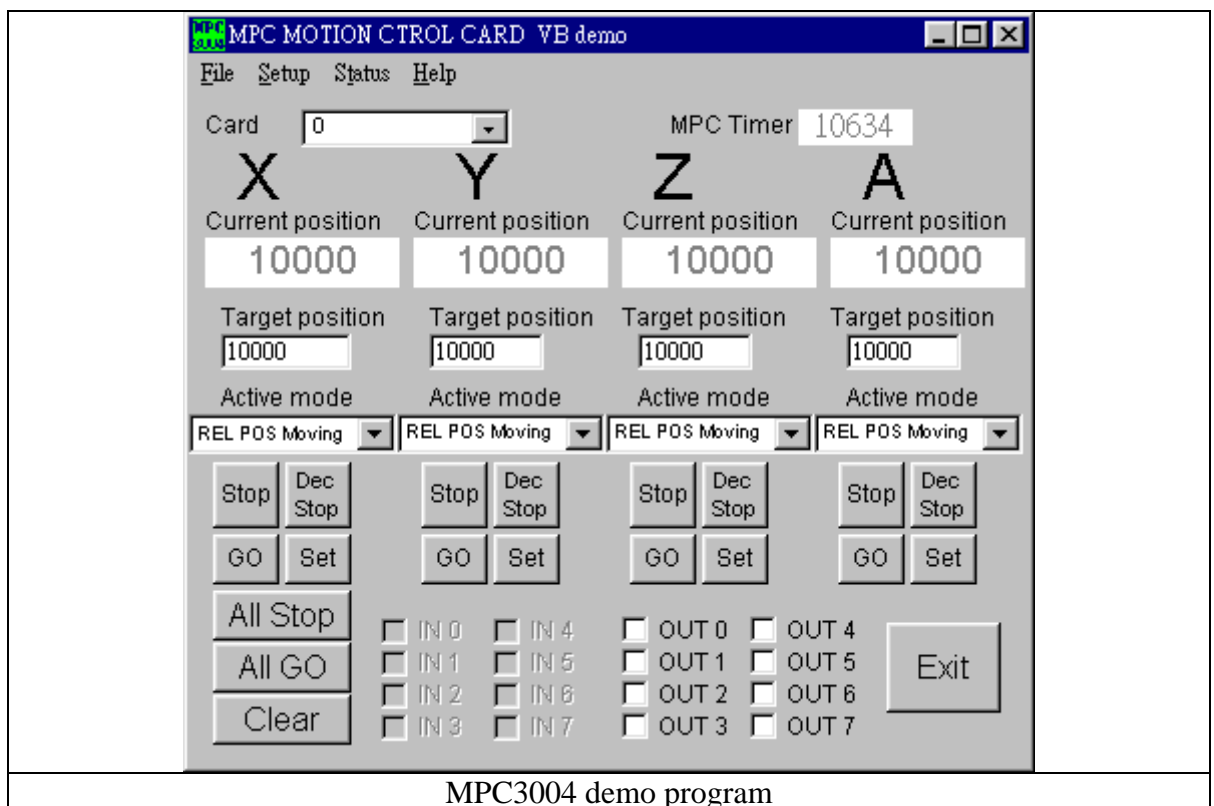

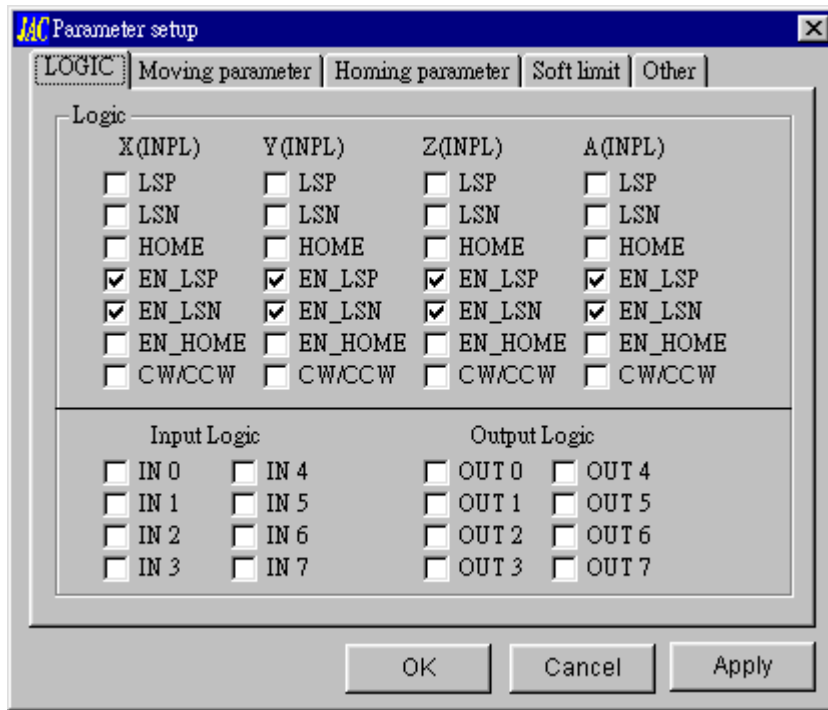

Parameters setup screen for MPC3004

Note: Since the default polarity of over-travel limit switch is normally close, be sure to change the polarity (un-mark LSP,LSN) if your hardware is normally open or no hardware connected.



Status echo screen



Status echo screen

Note: LS+,LS- activated, motion can not proceed

10. Applications

- Control AC/DC servo motor/driver with pulse type input
- Control various of stepping motor (PM/Hybrid/Micro-step)
- Any combination mixed control servo and stepping motor
- Control 4 servos with one card, easy to add on more cards to control more devices
- As multiple of frequency generator up to 1 MHz
- Control precision machinery, or semi-conductor package equipment

11. Ordering information

<u>PRODUCT</u>	<u>DESCRIPTIONS</u>
MPC-3004	4-axis Motion Control Card for Servo/Stepping Motor Control
ADP-3004ADIN(N)	DIN rail mounted wiring board for MPC-3004/2004 ,HDB15 pin connector General output: 8 power N-MOS
ADP-3004ADIN(R)	DIN rail mounted wiring board for MPC-3004/2004 ,HDB15 pin connector General output: 8 relays
FVC01	F to V Module
M265050150	50-pin SCSI-II cable 1.5M
M265050300	50-pin SCSI-II cable 3.0M