

UPP Piping Systems

Electrofusion Welding Instructions

Safety

Important!

UPP Systems must only be installed by fully trained and certified installers.

Failure to follow installation instructions will invalidate warranty and installer certification!

Electrofusion Safety

- UPP Welding Units must never be operated in Zone 1 or Zone 0 areas (Hazardous area definitions are from European Directive 1999/92/EC and guidelines can be found in the APEA Blue Book 2nd Edition).
- Ensure Welding Units are connected to a power supply that meets the requirements detailed in the user manual and are within the requirements of any local authority or regional legislation.
- An important requirement of any type of piping system is to safely connect all metallic components to ground. Metallic components, and more general conductive materials, due to their high capacitance, can have the potential to store a high amount of electrostatic energy (sparks discharge can only be observed over conductive elements).
- All exposed metal parts used in UPP System installations should be adequately grounded to a dedicated earth ground electrode and brought to a potential equal to that of other metal parts in the close proximity.
- Use ONLY FFS EF1-110 or EF1-230 welders with UPP Piping. Do NOT use these welders with other manufacturer's piping or fittings.

Chemical Safety

- Where using chemicals (such as Acetone) during the installation of UPP systems products, be sure to follow all safety guidelines given on the chemical containers themselves or on any accompanying literature.

Confined Space

- Some installation of UPP products may occur in confined spaces where a lack of oxygen and a concentration of toxic vapors is likely to be experienced.

Such working conditions are dangerous and all local health and safety guidelines for working in such environments should be followed.

Material Handling

Protective Equipment

- Ensure the correct personal protective equipment (PPE) is used at all times in line with local health and safety requirements.

Material Safety Data

- Ensure all safety data is accessed and used while installing UPP Systems (Material Safety Data Sheets are available in the download area of the UPP website).

Transport & Storage

- UPP products should be transported and stored in accordance with the guidelines contained in Section 1.

Heavy items

- Heavy items should be handled using suitable lifting equipment operated by authorised personnel.

Contents

Safety	2
Overview	4
Installation Guidelines	4
Electrofusion Instruction	4
Electrofusion Procedure Overview	5
Electrofusion Preparation Details	6
Cutting pipe.....	6
Scraping.....	6
Cleaning.....	7
Mark Insertion Depth	7
Marking Insertion Depth by Pre-Fitting	7
Clamping	8
Welding	8
Verify Weld Completion.....	9
Welding Secondary Containment Pipe And Fittings	10

Overview

The polyethylene construction of UPP pipe allows all connections to be joined using an electrofusion welding process. This provides a joint which is stronger than the pipe itself, and with no leak paths.

Electrofusion is carried out quickly and simply using specialist tools available from FranklinFueling.

A large variety of electrofusion fittings are available, from simple couplers (for making in-line pipework joints), to welded terminations (for terminating double wall secondary containment pipework) and entry seals.

Installation Guidelines

Follow the guidelines below to insure a successful installation:

- All pipe must be cut square.
- All pipes must be scraped to remove the oxidation area before Electrofusion.
- All Spigot fittings supplied un-bagged must be scraped to remove the oxidation area before electrofusion.
- Pipes, fittings and sockets must be cleaned with acetone where they join.
- All joints should have the pipe inserted into the electrofusion fitting ensuring that the marked insertion depth is reached.
- Joints must not be under any stress during welding or until ambient temperature is reached after welding.

Electrofusion Instruction

Organise all necessary tools and equipment on the job site prior to commencing the installation of pipe and fittings.

The basic installation tool set should always include:

- **UPP Electrofusion welder.**
- **Pipe cutter.**
- **Pipe Scraper.**
- **Cleaning Solvent.**
- **Straight and angled clamps.**
- **Permanent marker or Chinagraph pencil (white, yellow or red).**
- **Tape measure.**

Refer to the following sections for more detailed information on the above tooling.

Electrofusion Procedure Overview

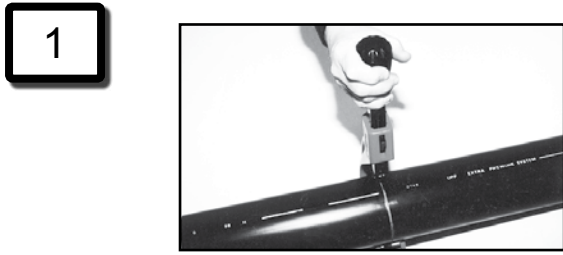

1 Measure and cut pipe to required length allowing for correct insertion depth into welding coupler.

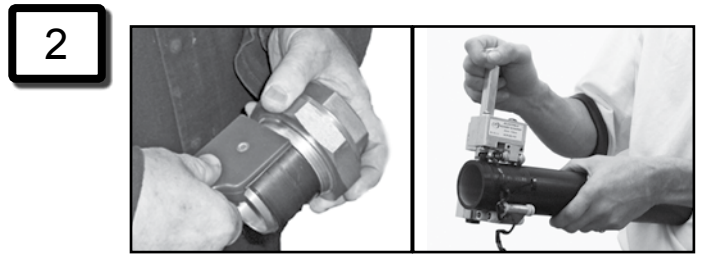

2 Use one of the scraping tools provided in the UPP installation box to prepare the pipes and fittings for welding.

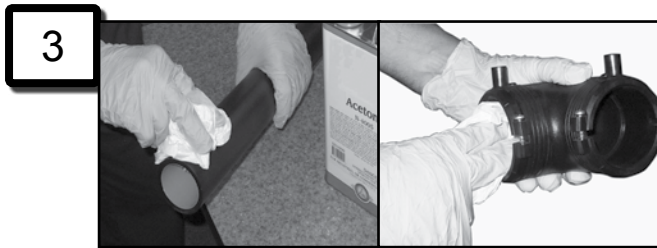

3 Clean scraped areas of pipe/fitting using a lint free cloth moistened with Acetone.



4 Measure and mark pipe to indicate correct insertion depth into fusion fitting.



5 Clean bore of the welding coupler with Acetone.

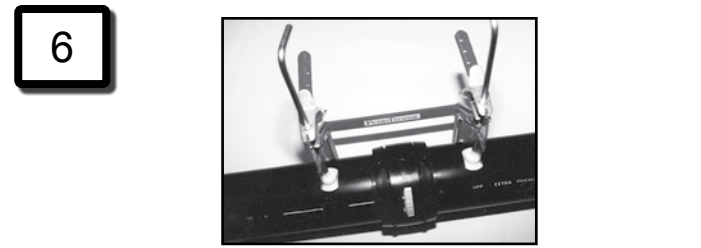

6 Assemble the joint and hold in place with clamp. Check that insertion is up to the marked depth indication.



7 Connect welder to clamped assembly and follow welding unit instructions. Ensure appropriate welding cables are used.

Note: Case-mounted EF1-110 shown. EF1-230 Handheld welder can also be used.

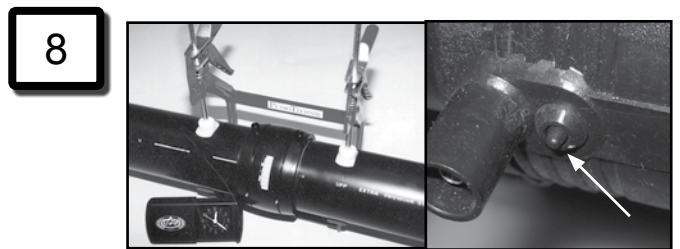

- Check insertion depth mark for movement.
- Check that welding completion indicators are out.
- Allow joint to cool to ambient temperature. Wait at least 20 minutes before any stresses are exerted upon the assembly.

Electrofusion Preparation Details

Cutting pipe

Primary pipe (single wall pipe)

- Cut primary pipe only by using the appropriate UPP pipe cutter tool and never using a hand saw. The UPP cutting tool gives 100% straight cuts every time and no burring ensuring that the cut ends fit flush into any welding couplers or fittings.



Cutting primary pipe using UPP cutting tool

- There are two different pipe cutters available for varying pipe diameters.

Tool	Pipe Diameter (mm)	Pipe Diameter (inches)
P.CUT	50-110	1½-4
P.CUT MED	110-160	4-6

Secondary containment pipe (double wall pipe)

- Cut secondary containment pipe in exactly the same way as primary pipe, using the UPP pipe cutting tools.
- When cutting coaxial pipe it is possible to cut through both pipe layers in one go. Be careful of this if you want your primary pipe length longer than the secondary sheath (inside sumps and chambers etc.).



Cutting Secondary Pipe Using UPP Cutting Tool

Duct pipe

- It is not possible to cut UPP corrugated duct pipe using the UPP pipe cutting tools. A hand saw should be used to cut the duct using the corrugations as guides to help create a clean, straight cut.

Scraping

It is imperative that the scraping of pipes and fittings is carried out exactly as described here to remove the layer of oxidised material that builds up on the pipe when it is exposed to air. This oxidised layer hinders the quality of the weld and must be removed.

Note: NEVER, under any circumstance, use sand paper on primary or secondary pipe.

Primary pipe (single wall pipe)

Primary pipe must be scraped using the UPP scraping tool. These tools remove a controlled outer layer of oxidised polyethylene over the length of the pipe which is inserted into a coupler or electrofusion fitting.



Scraping UPP Primary Pipe Using Scraping Tool

Secondary containment pipe (double wall pipe)

- Secondary containment pipe has to be scraped using the UPP hand scraper (SCR.HAR). A layer of plastic must be removed all along the length of pipe to be inserted into the welding coupler or electrofusion fitting.



Scraping UPP Secondary Pipe Using Hand Scraper

Non-Electrofusion Fittings

Non electrofusion fittings (i.e. those that need an electrofusion coupler to be welded) if supplied Un-bagged, must be scraped with the UPP hand scraper before welding'



Scraping UPP Non-Electrofusion Fitting with Hand Scraper

The polyethylene area of these fittings must be scraped using the UPP hand scraper to remove a layer of oxidised polyethylene along the whole length that is to be inserted into the welding coupler.

Electrofusion Fittings / Welding Couplers

Electrofusion fittings are those with welding elements built into them - these do not require scraping before being used, but must be cleaned with a solvent (See below).

Cleaning

To ensure that there is no grease, moisture or dirt in the electrofusion zone during welding it is important to clean all the pieces of the assembly prior to welding. The following solvents may be used:

- Acetone (preferred)
- Isopropyl alcohol
- Trichloroethane

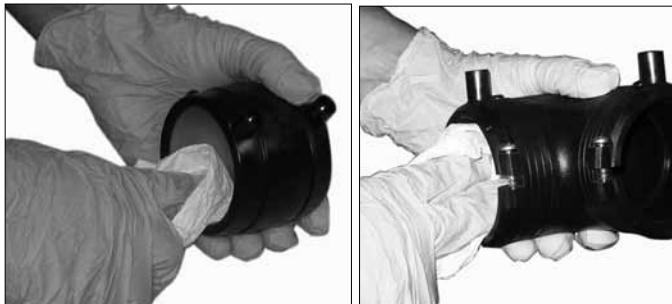

Using An Acetone-Soaked Cloth To Clean A Welding Socket and Seal Spigot

Do NOT USE solvents that leave an oily film on the joining surface such as turpentine, petrol or synthetic dilutents.

The surfaces to be cleaned include:

- All scraped areas of pipes and fittings
- The inside of electrofusion fittings and welding couplers

Once the areas of pipes and fittings to be welded have been wiped clean, avoid touching the cleaned areas or allowing contact with any sources of grease/dirt.

Note: In wet weather, protect the fittings from water. Water in the fittings can contaminate the welds and cause failures.

Mark Insertion Depth

Mark the insertion depth on pipe ends using a permanent marker or China-graph pencil and a ruler

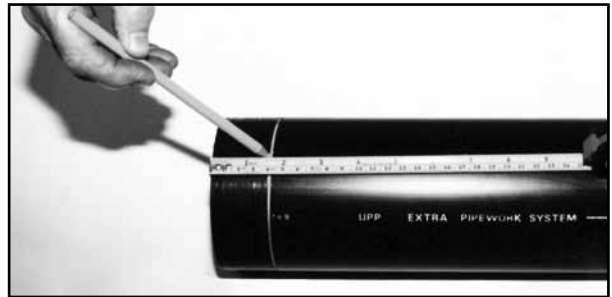

Using a Ruler to Mark Insertion Depth

The following table shows the correct insertion depth into UPP primary electrofusion fittings

Description	Ø mm	Product Code	Insertion Length	
			mm	Inches
Welding Coupler	50	02-50	25	1
	63	02-63	30	1 3/16
	90	02-90	36	1 3/8
	110	02-110	41	1 9/16
90° Elbow Electro-fusion	50	03-050-EIF	44	1 3/4
	63	03-063-EIF	48	1 7/8
	90	03-090-EIF	62	2 7/16
	110	03-110-EIF	71	2 3/4
45° Elbow Electro-fusion	63	04-063-EIF	48	1 7/8
	90	04-090-EIF	62	2 7/16
	110	04-110-EIF	71	2 3/4

Marking Insertion Depth by Pre-Fitting

The insertion depth can also be marked by inserting the cleaned pipe fully into the fitting and marking around the fitting.



Marking Insertion Depth

Inscribe a line around the junction of the pipe and fitting.

Note: When using this method, make sure the pipe is fully inserted. Visually check if possible, or listen/feel for the pipe positively contacting the stop.

Clamping

Check for correct alignment of the assembly both vertically and horizontally and ensure that it is not subjected to any bending load or weight that could deform to the joint while it is in a molten state.

Use UPP clamps to keep the assembly in the correct alignment position, preventing any movement during the welding and subsequent cooling process.

If a clamp cannot be used, for example in a small tank chamber, precautions need to be taken to ensure that the assembly is not under any stress.

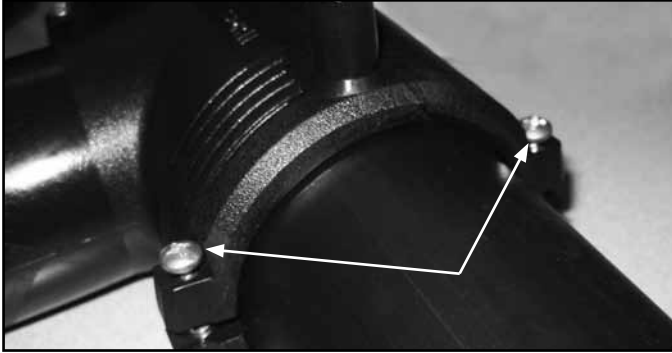

Screw Clamps

The screw clamps on some fittings are used to hold the pipe in place for clamping. The piping may have a pre-load force that could pull the pipe out slightly before clamping. Tighten the screws to hold the piping in place while the clamps are installed.

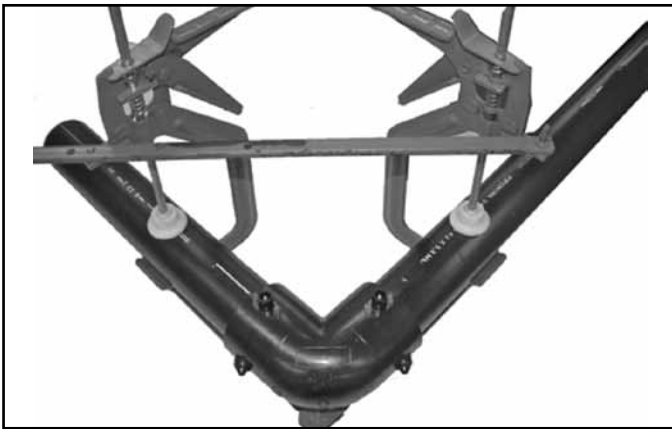

Angled Clamp Installed



Straight Clamp Installed

Welding

Overview

UPP 230 volt and 115 volt intelligent Welding Units supply the precise electrical energy to fuse two UPP products together safely on site. The heat causes the pipe and joint surfaces to melt and fuse. After electrofusion, the assembly is left to cool while the polyethylene solidifies to form a homogenous union stronger than either pipe or fittings.

Note: UPP welders use a constant current output. UPP components must never be welded with other brands of welding unit.

Both types of welder can be used from the mains supply or from a generator.

The welding machine measures the ambient temperature and the welding coupler/electrofusion fittings resistance values. The welder must be close to the same temperature as the joint it is welding.

Bridging

A maximum of three primary couplers or primary electrofusion fittings may be welded at the same time by using bridging leads. Most electrofusion couplers and fittings have a resistance index number marked onto them inside a circle: i.e. Ⓢ. The total value of the index number of the three items to be welded must not exceed 10. If the fitting lacks a resistance index number then it must be treated as having an index number of 10. A list of resistance numbers can be seen in the following table.

Description	Part number	Resistance index number
Primary welding socket	02-50	2
Primary welding socket	02-63	2
Primary welding socket	02-90	4
Primary welding socket	02-110	6
Primary welding socket	02-160	10
Primary welding socket	02-200	10
Electrofusion elbow 90°	03-050-EIF	4
Electrofusion elbow 90°	03-063-EIF	4
Electrofusion elbow 90°	03-090-EIF	7
Electrofusion elbow 90°	03-110-EIF	9
Electrofusion elbow 45°	04-063-EIF	4
Electrofusion elbow 45°	04-090-EIF	7
Electrofusion elbow 45°	04-110-EIF	9
Electrofusion equal tee	08-050-EIF	4
Electrofusion equal tee	08-063-EIF	4
Electrofusion equal tee	08-090-EIF	7
Electrofusion equal tee	08-110-EIF	9
Electrofusion reducer	09-090-063-EIF	5
Electrofusion reducer	09-110-090-EIF	7
Electrofusion entry seal	302 Flange	1
Electrofusion entry seal	303 Flange	2
Electrofusion entry seal	305 Flange	3
Electrofusion entry seal	308 Flange	3

Welding Cables Chart

Type of Fitting	Welding Cable Colour	Size of Welding Pim (mm)	Current (amps)	Weld Time @ 20C (Seconds)
Primary	Red	4	4	184
Secondary	Green	2	5	80
Fusion Chamber	White	2.3	7	360
Large Diameter (10amp)	Black	2	10	365

Note: A resistance value of X means that there is no marked resistance value on the fittings and these should be treated as having values of 10.

Connect the leads from the welding unit to the fittings per the chart above. The leads should fit firmly. It is very important to use the correct cable.

Welding Process

After the welder is turned on, press the start button to begin the welding process. The weld time is determined by the welder and no further input is required.

Note: Before pushing the start button, the welder must show a green ready light. Hold the start button down momentarily and then release it.

The welder display will show welding progress. Once completed it is good practice to write the time on the fitting to determine when clamps can be removed.

Wait 20 minutes for the weld to cool before removing clamps.

Resetting the welder

Always reset the welder between welds by depressing and holding the start button for 3 seconds.

Verify Weld Completion

The first indication of a successful weld is that the welder's green 100% LED is lit.

Most fittings have a weld indicator built in. After the weld the center of the indicator should protrude above the surrounding area.

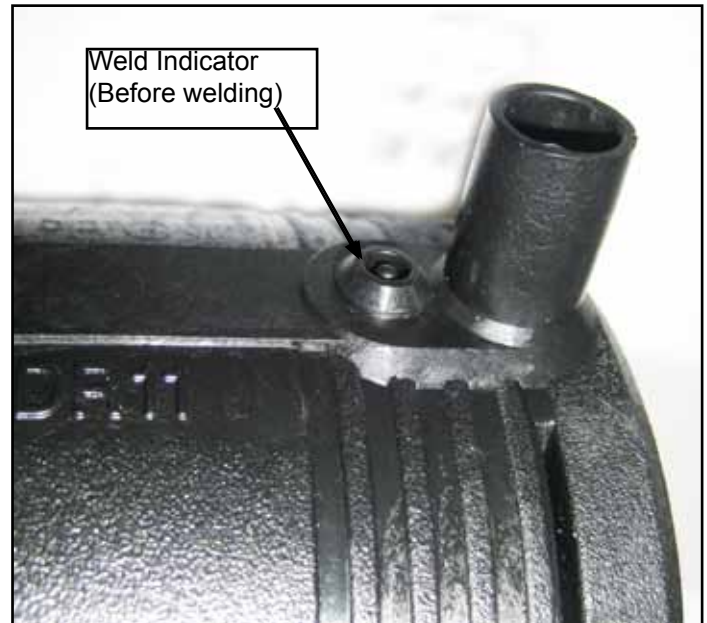

Weld Indicator Location

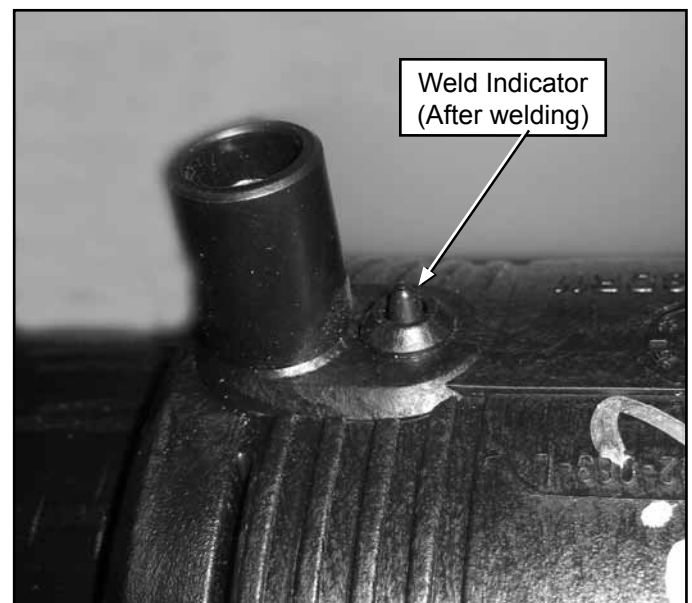

Weld Indicator Completed

Look in the Tightness Testing Section for complete inspection procedure.

Troubleshooting

- Refer to the welder documentation for complete welder operation and error codes.
- If power is lost during the weld, allow the fitting to cool in place for at least an hour and then restart the weld process.

Welding Secondary Containment Pipe And Fittings

- Green welding cables should be used for welding secondary containment pipe
- Some welding unit displays will read: "Secondary Mode" and after five seconds "Connect welding element"

Procedure

1. Cut Co-axial pipes to required length using the pipe cutter as shown.



Cut Secondary Pipe

2. Trim or slide the secondary pipe back 40 mm ($1 \frac{9}{16}$ ").

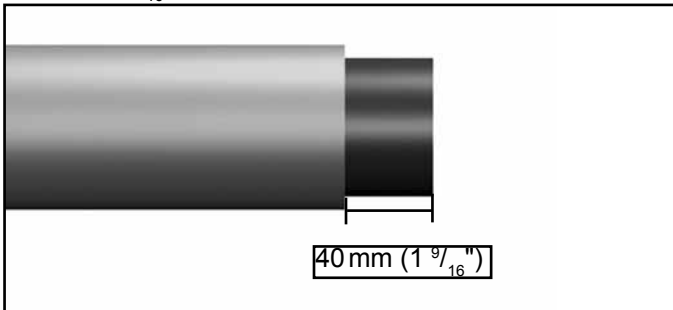

Trim or Slide Secondary

3. Prepare primary and secondary pipe using hand scraper.
4. Secondary pipe must be scraped all the way up to 150 mm (6.0") from its end.

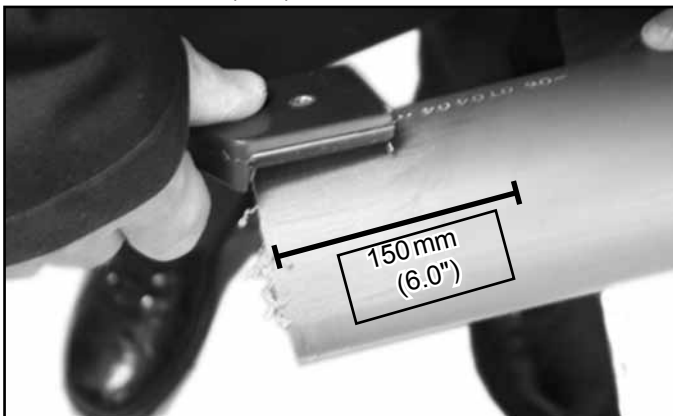

Scrape Secondary

5. Clean primary pipe end with acetone.



Clean Secondary with Acetone

6. Pre-clean secondary pipe 200 mm (8.0") from end.
7. Clean reducer with acetone and slide it along secondary pipe - small end first.

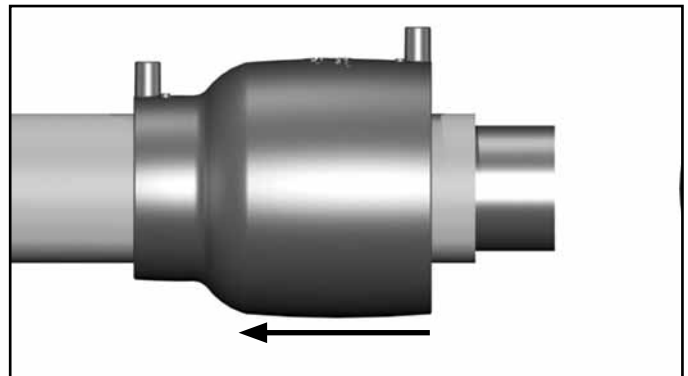

Slide Reducer on Secondary

8. Ensure elbow or tee primary spigots measure 30 mm ($1 \frac{3}{16}$ "), and cut to length if required.

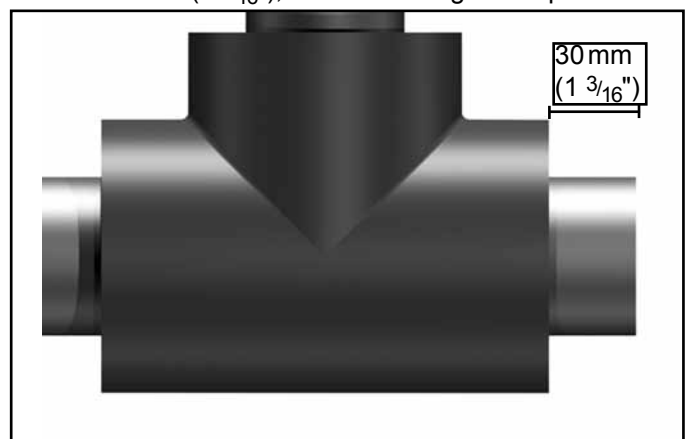

Measure Primary Spigots

9. Prepare Primary and Secondary spigots of tee/elbow with hand scraper.



Scrape Primary and Secondary

10. Clean Primary spigots of tee/elbow with acetone.
11. Clean Secondary spigots of tee/elbow with acetone.



Clean with Acetone

12. Clean primary welding coupler using acetone.
13. Fit couplers to primary Tee/Elbow spigots.



Clean Weld Coupler with Acetone

14. Insert Primary pipe into welding couplers (ensure pipe is fully inserted).



Insert Primary Pipe into Coupler

15. Before welding check that the secondary containment reducer is fitted in correct location over scraped zone of secondary pipe.
16. Weld Primary couplers.
17. Once weld is complete allow to cool for at least 30 minutes.
18. If needed, do not weld the secondary until the primary piping has been inspected.
19. Clean inside of reducer spigot and outside of the Tee/Elbow spigots with acetone.



Clean Inside of Secondary

20. Slide reducers into place (ensure full insertion).
21. Weld secondary.
22. Allow to cool for at least 30 minutes before putting any stress on the joint.



Assembled Secondary Fittings



Franklin Fueling Systems

www.franklinfueling.com

3760 Marsh Road • Madison, WI 53718, U.S.A.

Tel: +1 608 838 8786 • Fax: +1 608 838 6433

Tel: USA & Canada 1 800 225 9787 • Tel: México 001 800 738 7610

Franklin Fueling Systems GmbH

Rudolf-Diesel-Strasse 20 • 54516 Wittlich, GERMANY

Tel: +49-6571-105-380 • Fax: +49-6571-105-510

Franklin Fueling Systems LTD

8 Olympus Close • Whitehouse Industrial Estate

Ipswich, Suffolk IP1 5LN • United Kingdom

Tel: +44 1473 243300 • Fax: +44 1473 243301