



Artisan Technology Group is your source for quality new and certified-used/pre-owned equipment

- FAST SHIPPING AND DELIVERY
- TENS OF THOUSANDS OF IN-STOCK ITEMS
- EQUIPMENT DEMOS
- HUNDREDS OF MANUFACTURERS SUPPORTED
- LEASING/MONTHLY RENTALS
- ITAR CERTIFIED SECURE ASSET SOLUTIONS

SERVICE CENTER REPAIRS

Experienced engineers and technicians on staff at our full-service, in-house repair center

*InstraView*SM REMOTE INSPECTION

Remotely inspect equipment before purchasing with our interactive website at www.instraview.com ↗

WE BUY USED EQUIPMENT

Sell your excess, underutilized, and idle used equipment. We also offer credit for buy-backs and trade-ins. www.artisanng.com/WeBuyEquipment ↗

LOOKING FOR MORE INFORMATION?

Visit us on the web at www.artisanng.com ↗ for more information on price quotations, drivers, technical specifications, manuals, and documentation

Contact us: (888) 88-SOURCE | sales@artisanng.com | www.artisanng.com



HPLC

User's Guide

For 32 Karat™ Software
Version 5.0

715085 AA
August 2001

Beckman Coulter, Inc.
4300 N. Harbor Blvd., Fullerton, CA 92835
© Copyright 2001 Beckman Coulter, Inc.
Printed in U.S.A.

Table of Contents

Preface

Instructions for using the Data Samples	vi
Safety Information	viii

Introduction to HPLC

Overview	1-1
General Description	1-1
Common Modes of Chromatography	1-2
Partition Chromatography	1-2
Normal-Phase Partition Chromatography	1-2
Reversed-Phase Partition Chromatography	1-2
Adsorption Chromatography	1-2
Ion-Exchange Chromatography	1-3
Size-Exclusion Chromatography	1-3

System Overview

Introduction	2-1
Hardware, Plumbing and Operation Overview	2-3
Pumps	2-3
Model 166 Programmable UV/Visible Detector Module	2-4
Model 168 Programmable Diode Array Detector Module	2-5
Injection Devices	2-7
Basic Plumbing of the HPLC Modules	2-8
Pump Internal Plumbing	2-10

Starting 32 Karat Software

Tool Bar	3-2
Menu Bar	3-2
Creating and Configuring an Instrument	3-3
Creating a New Instrument	3-3
Configuring the New Instrument	3-4
Auto Configuration	3-6
Additional Configuration Information	3-8
Detector Names	3-8
Verification of Pump Configuration	3-10
Verification of Autosampler Configuration	3-11

Direct Control

Introduction.....	4-1
Direct Control Window.....	4-2

Creating and Editing a Method

Introduction.....	5-1
Creating a Method	5-1
Isocratic Methods.....	5-2
Pump Initial Parameters Tab.....	5-5
Detector Initial Parameters Tab	5-6
Time Program Tab	5-7
Injector Tab	5-10
Manual Injector.....	5-10
Autosampler.....	5-11
Saving a Method	5-12
Gradient Methods	5-13
Pump Initial Parameters Tab.....	5-16
Detector Initial Parameters Tab	5-17
Time Program Tab	5-18
PDA Methods.....	5-22
Editing a Method	5-29

Running the System

Introduction.....	6-1
Setting up a Single Run	6-2
Setting up a Sequence Run	6-4
Creating a Sequence.....	6-4
Running the Sequence	6-9

Optimizing the Method

Optimize Integration Events	7-2
Create a Peak Table.....	7-12

Calibration

Introduction.....	8-1
Single Point Calibration.....	8-2
Editing the Peak Table	8-2
Running the Calibration Sample.....	8-4
Multi-Point Calibration.....	8-6
Editing the Peak Table	8-6

Creating a Calibration Sequence.....	8-8
Running the Calibration Sequence	8-11
View the Calibration Curve.....	8-12
Acquire an Unknown Sample	8-13
Creating Reports	
Introduction.....	9-1
Getting Started	9-2
The Method Custom Report Window	9-3
Adding Field Information	9-4
Formatting the Report Text.....	9-7
Adding a Chromatogram to the Report.....	9-8
Adding Report Tables	9-13
Previewing the Method Custom Report.....	9-15
Save the Custom Report Format as a Template	9-16
Appendix 1	
Additional Resources	Appendix 1-1
32 Karat Online Help.....	Appendix 1-1
Installation and Maintenance Manual.....	Appendix 1-1
Beckman Coulter Service	Appendix 1-1
Help by e-mail.....	Appendix 1-1
Other references	Appendix 1-2
Appendix 2	
HPLC Calculations	Appendix 2-1
Relative Retention.....	Appendix 2-1
Capacity Factor	Appendix 2-2
Plates per Meter	Appendix 2-2
Area / Height Calculations.....	Appendix 2-3
Theoretical Plates.....	Appendix 2-3
Peak Asymmetry (Tailing Factor).....	Appendix 2-3
Resolution	Appendix 2-4
Appendix 3	
Understanding PDA Data.....	Appendix 3-1
Mixed View w/ 3D option.....	Appendix 3-2
Contour plot	Appendix 3-2
Spectrum	Appendix 3-3

Chromatogram	Appendix 3-3
3D Plot	Appendix 3-3

Appendix 4

System Administration	Appendix 4-1
-----------------------------	--------------

Preface

The 32 Karat™ User's Guide is a self-paced introduction to the operation of the Beckman Coulter, Inc. System Gold HPLC and the 32 Karat Software version 5. It contains a brief introduction to the technique of liquid chromatography; an overview of the System Gold hardware; tutorials for the most frequently used software features; and an appendix of useful information.

The 32 Karat User's Guide has been designed to assist users who are new to LC or the 32 Karat Software in beginning to use both the software and the instrument. It is largely built on exercises that are designed to take you step-by-step to a point where you can begin to create your own methods, generate and analyze data, and report results. It does not attempt to cover every possible feature in the system or every aspect of liquid chromatography.

The on-instrument activities contain specific instructions for users with ultraviolet and photodiode array detector systems. Follow the instructions for the detector(s) installed on your system.

The activities in this manual are progressive. Each builds on the previous ones. To get the most from this manual, work through all the activities, in order.

The activities that teach data reprocessing, calibration, and reporting, are all based on data collected with an ultraviolet detector system. The steps in these procedures are very similar regardless of the detector type used, so these exercises are important for users of all detector types. Data files for the post-run exercises are installed with the 32 Karat Software. If your instrument does not have a UV detector, you can manually configure a virtual UV instrument in the software so that you can do these exercises.

Additional information can be found in the 32 Karat Online Help. This can be accessed at any time while using the 32 Karat Software through the Help menu located on the menu bar, by pressing the F1 key while working within the software, or any time you see a "Help" button displayed within an application window.

This manual was created by a team of technical writers, scientists, and engineers at Beckman Coulter, Inc. We value your feedback. Please let us know how we can improve future editions of this manual.

Send your comments to: 32karat@beckmancoulter.com, and include User Manual in the subject line. Questions concerning the exercises can be sent to the same address.

Fullerton, California

August, 2001

Instructions for using the Data Samples

Included in the software package are several sample data and method files. These are located in the Data Samples folder, which is a sub-directory to the 32Karat folder that was created when your software was installed. The following information is also contained in the "Readme.doc" file located in the Data Samples folder. It is **IMPORTANT** to read and understand the following before using the sample files.

This folder contains the following files:

Internal std cal.met
multilevel calibration.met
ISTD Calib Level 1 Rep 1.dat
ISTD Calib Level 1 Rep 2.dat
ISTD Calib Level 2 Rep 1.dat
ISTD Calib Level 2 Rep 2.dat
ISTD Calib Level 3 Rep 1.dat
ISTD Calib Level 3 Rep 2.dat
ISTD Calib Level 4 Rep 1.dat
ISTD Calib Level 4 Rep 2.dat
multi calibration level 1.dat
multi calibration level 2.dat
multi calibration level 3.dat
multi calibration level 4.dat
multi calibration level 5.dat
multi calibration level 6.dat

Purpose of these files

The Data Samples folder contains data and method files to supplement the exercises in the User's Guide for the 32 Karat Software. The files were created solely for the purposes of this tutorial. They are intended as training tools only, and are not to be used for system validation or any other purposes.

The multi-calibration files can be used for multiple-level calibration tutorials.
The ISTD files can be used for internal standard tutorials.

Using the files

Some of these files are referred to by name in the 32 Karat User's Guide. By using these files, the images you see on the computer screen and the images in the training manual will be the same.

IMPORTANT NOTICE: Duplicate these files before use

Processing these data files and methods in the 32 Karat Software will cause changes to the files. To keep the original files unaltered and available for later use in these exercises, please follow the steps below.

1. Open Windows NT Explorer. To open this utility, right click on the Start button in the Windows NT toolbar and select Explore.
2. Navigate to the Data Samples folder. It is a sub-directory of the 32Karat folder.
3. In the left-hand pane of the Explorer window, click on the Data Samples folder to open it.
4. From the menu bar at the top of the Explorer window select File | New | Folder. A new folder will be added to the Data Samples folder. The “New Folder” will be highlighted, which indicates that the name may be edited. Type a new name. The name of the individual who will be using the tutorial exercises in the User’s Guide is a good choice.
5. Select all of the data files listed above, but do not select the new folder. There are several ways to do a multiple file select. Use any one of the following:
 - Select the first file in the list by clicking on it. Hold down the Shift key, and click on the last file in the list. All the files between these two files will be selected.
 - Select a file by clicking on it. Hold down the Ctrl key, and click each individual file in the list.
 - Using the mouse, you can click and drag a box around the files to be selected.
6. When all the files are selected (highlighted), select Edit | Copy from the menu bar (or use the keyboard shortcut Ctrl-C). Double click on the new folder to open it. Then select Edit | Paste from the menu bar (or use the keyboard shortcut Ctrl-V).
7. You have now created a copy of the sample files in a new folder. When the manual asks you to open a file, open the copy you have just created, and not the original file. **DO NOT USE THE ORIGINAL FILES!** Save all methods and sequences you create as part of the tutorial in this new folder.
8. A backup set of files is included in case the originals become altered. These are stored in the file “Backup Files.exe.” Running this executable file will restore the original set of sample files. When running the backup files program, you may be prompted to over-write existing files. Select “Yes.” The contents of the Data Samples file will be replaced by this action, including any changes you have made to the original set of data and method files.

Safety Information

The Installation and Maintenance Manual included with your system contains important safety information and instructions for the hardware and accessories of the system.

The symbols displayed (see below) in the manuals and on the instrument are reminders that all safety instructions should be read and understood before installation, operation, maintenance or repair to the instrument is attempted.

When symbols are displayed in the manuals, pay particular attention to the safety information associated with the symbol.

 WARNING	This icon accompanies text and/or other international symbols dealing with hazards to personnel. When present, it indicates that a potential hazard to your personal safety exists if information stated within the “ WARNING ” paragraph is not adhered to or procedures are executed incorrectly.
---	--

 CAUTION	This icon accompanies text and/or other international symbols dealing with potential damage to equipment. When present, it indicates that there is a potential danger of equipment damage, software program failure or that a loss of data may occur if information stated within the “ CAUTION ” paragraph is not adhered to or procedures are executed incorrectly.
---	--

Section 1 - Introduction to HPLC



Overview

This section describes the common modes of liquid chromatography and how these processes are performed by the System Gold™ HPLC instrument using the Ultraviolet (UV) and Photodiode Array (PDA) detectors.

General Description

The System Gold HPLC instrument separates sample components within a liquid chromatographic column usually constructed from stainless steel tubing and packed with a coated silica matrix, though alumina, porous polymer particles or ion-exchange resins are also used. The separation takes place using one of several modes of chromatography. All of these modes are generally referred to as High Performance Liquid Chromatography (HPLC).

In the System Gold HPLC, sample is injected into the column using a highly pressurized mobile phase (the eluent) and sample components then migrate differentially through the stationary phase (the packing) within the column.

The basic method for detecting samples uses the absorbance of light. This method is utilized in UV and PDA detection. As these components exit the column and pass through the detector, a single wavelength UV detector or a multiwavelength photodiode array detector (PDA) measures absorbance and transmits the signal to the computer. The signal can also be transmitted to an external recorder, integrator, or data system through an analog output. The signal may be plotted graphically in the form of a chromatogram and analyzed.

The System Gold HPLC instrument may be used to separate many different kinds of samples, including peptides, proteins, nucleic acids, ions, enantiomers, and pharmaceuticals. HPLC separation methods are efficient, highly selective, and widely applicable. It provides a complimentary alternative to other separations techniques such as gas chromatography and capillary electrophoresis.

Common Modes of Chromatography

Partition Chromatography

Partition chromatography, as the name suggests, involves the division of analyte molecules between two phases within the column, the mobile phase and the stationary phase. Modern applications typically utilize a liquid mobile phase which is passed through a column containing an organic stationary phase that is chemically bonded to the surface of the support particles making up the column packing.

Due to the physical and chemical properties unique to individual molecules or ions, the separation takes place as each analyte exhibits more or less affinity for the two phases within the column. Essentially, different analytes will be “held” by the stationary phase to different degrees (though some not at all) and will exit the column at different times.

The types of bonded-phase packings can vary greatly and their applications are generally divided into two categories based upon the relative polarities of both the mobile and stationary phases used. These two types of partition chromatography are referred to as normal-phase and reversed-phase chromatography.

Normal-Phase Partition Chromatography

In normal-phase chromatography, the stationary phase is polar and the mobile phase is nonpolar. As such, a differential migration of species takes place as the sample is eluted through the column based upon the relative polarity of the individual analytes themselves. A polar analyte will have greater affinity for the polar stationary phase than it will for the relatively nonpolar mobile phase and will be more tightly bound to the column. In contrast, a nonpolar analyte will have greater affinity for the nonpolar mobile phase and will be held less tightly by the column. In this mode of separation, the least polar analyte is the first to be eluted from the column.

Reversed-Phase Partition Chromatography

In reversed-phase chromatography, the stationary phase is nonpolar and the mobile phase is polar. As such, a differential migration of species takes place as the sample is eluted through the column based upon the relative polarity of the individual analytes themselves. A nonpolar analyte will have greater affinity for the nonpolar stationary phase than it will for the relatively polar mobile phase and will be more tightly bound to the column. In contrast, a polar analyte will have greater affinity for the polar mobile phase and will be held less tightly by the column. In this mode of separation, the most polar analyte is the first to be eluted from the column.

Adsorption Chromatography

Adsorption chromatography uses a polar solid, usually silica or alumina, as the stationary phase to achieve separation of a wide variety of compounds. In this technique, both the analyte and the mobile phase are adsorbed onto the surface of the stationary phase and must compete with each other for available binding sites. The more polar the analyte, the more effectively it will be able to compete for available binding sites on the surface of the stationary phase and the more strongly it will be

retained. Very efficient and selective separations can thus be achieved by varying the composition of the mobile phase.

Ion-Exchange Chromatography

Ion-exchange chromatography utilizes a stationary phase consisting of charged functional groups attached to a polymer matrix, referred to as an ion-exchange resin. This technique is useful for separation of ions of like charge dissolved in an aqueous mobile phase. The separation mechanism is competition for the charged functional groups on the ion-exchange resin by the analyte ions and the mobile phase ions.

The types of ion-exchange resins can be sub-divided into two categories; cation-exchange resins and anion-exchange resins. Cation-exchange resins contain negatively charged functional groups for exchanging (separating) cationic species. Anion-exchange resins contain positively charged functional groups for exchanging (separating) anionic species. Additionally, the degree of retention within each of these categories can vary greatly depending upon the amount of the charge carried by the functional groups which are bound to the ion-exchange resin.

Size-Exclusion Chromatography

Size-exclusion chromatography, also known as gel chromatography, uses column packings consisting of small silica or polymer particles to achieve the separation of molecules in a manner very different from the other methods. These particles contain pores into which the analyte and mobile phase molecules can diffuse and the separation is carried out based solely upon the characteristic size and shape of the analyte molecules.

When the sample is injected onto the column, the analyte molecules are sorted by size and shape. Those molecules able to fit into the pores of the column packing will be retained by the column while those that are too large will not be retained and will be carried with the mobile phase. The length of time that the retained species will remain on the column depends upon the relative size of the molecules themselves. Molecules that are very much smaller than the pore size are more likely to become entrapped in most or all of the pores and will be the last to elute from the column. Molecules that are larger, but still able to fit into the pores, will be retained by fewer and fewer of the pores as their relative size increases. These molecules will have elution times which are directly proportional to their size and, to some extent, their shape.

Section 2 - System Overview

Introduction

The HPLC system is based on one of Beckman Coulter's programmable solvent delivery modules (pumps), i.e., the Model 118 Programmable Solvent Module, or one of the dual-pump Models 125/127 and 126/128 Programmable Solvent Modules. The 118, 127 and 128 Modules includes a System Control Center (SCC) display and keypad which permits controlling the pump and external modules directly. No computer or software is required when operating the SCC. The SCC feature must be disabled for systems being driven from a computer and 32 Karat Software. The 125 and 126 Pumps do not include the SCC feature and must be controlled via 32 Karat Software.

Each pump module has front panel access necessary for priming and maintenance procedures and bundled lines exiting rear panel of the pump to facilitate solvent, piston wash and drain line connections. The pump high-pressure outlet fitting is located at the bottom-front of the pump cabinet.

The Models 166 and 168 Detectors include plumbing lines exiting the front panel for ease of connection. Other detectors can be used with Beckman Coulter's HPLC system network provided that a SS420 Board or SS420x Device is used to process the analog signal.

The Models 502, 507, 507e and 508 Autosamplers are designed for easy plumbing access to the injection valve and column.

All Beckman Coulter HPLC system modules are housed in separate cabinets. Connectors and controls for power, external interfaces are located on the rear panels of the modules. Light Emitting Diodes (LEDs) which indicate the status of the device or its operation are located on front panels of all HPLC system modules.

The following pages will guide you through some of the basic hardware and operational features of the Beckman Coulter HPLC system. This will include a brief introduction to each of the various modules, basic plumbing and connections of the modules to one another, and an overview of their operational parameters.

Notice

This section is not meant to be comprehensive of the operation and maintenance of the Beckman Coulter HPLC System. For a more detailed description of these and other system parameters, refer to the Installation and Maintenance Manual included with your system.

The main components of the Beckman Coulter HPLC system include the pumps, detector, buffer reservoir, a sample injection mechanism, and the computer interface.

Figure 1 Beckman Coulter HPLC system overview

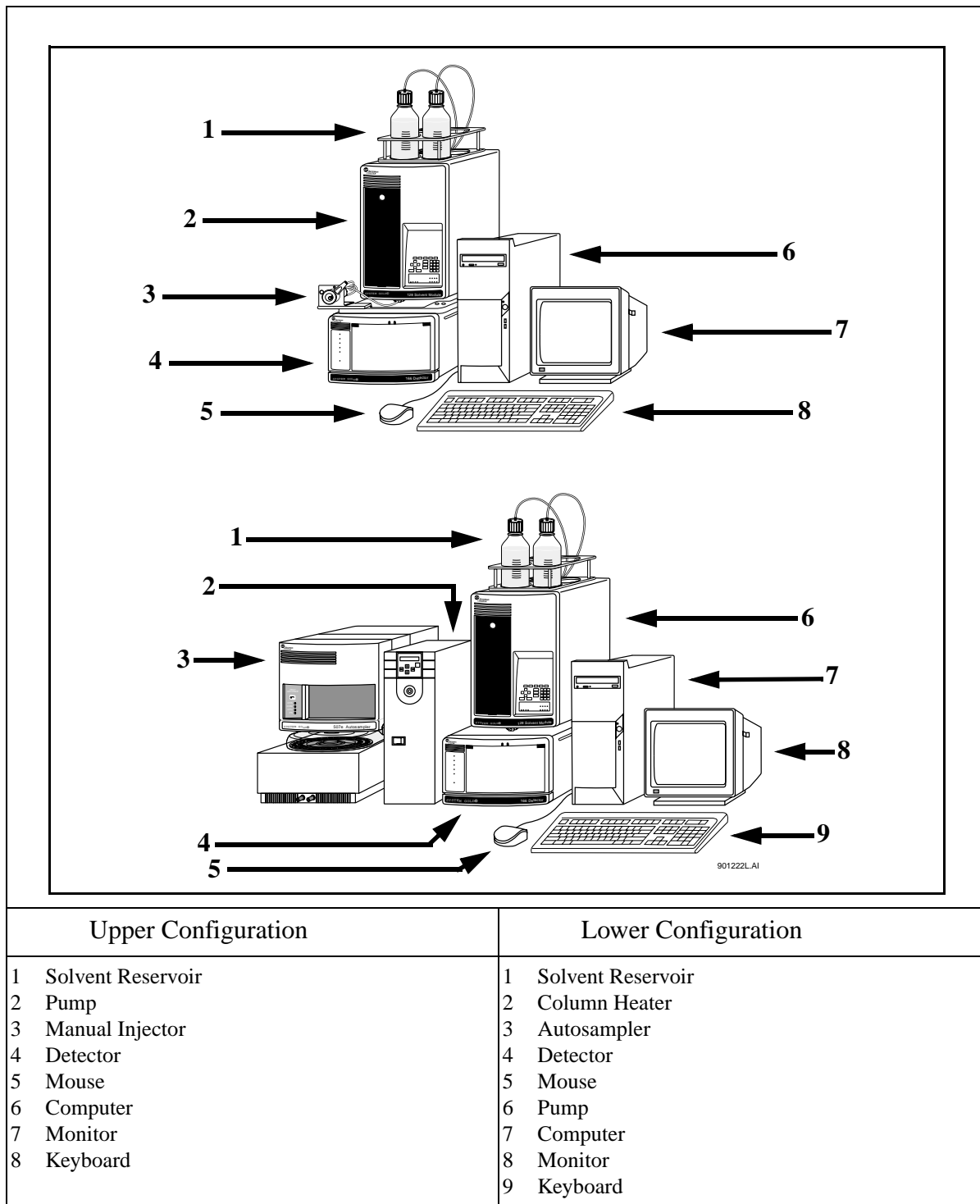

Hardware, Plumbing and Operation Overview

This section will discuss general theory of operation of the Beckman Coulter HPLC systems. The typical system comprises an injection device (manual injector or Autosampler), Solvent Delivery Module (pump) and either/or a programmable UV/Visible or diode array detector.

Pumps

Five basic pump models comprise the Beckman Coulter Solvent Delivery Modules (SDMs): Models 118, 125, 126, 127 and 128. Some models include the System Control Center (SCC).

Features of the various SDMs are presented in Table 1.

Table 1 Beckman Coulter SDM (Pump) Features

Model Number	Pump Heads	System Control Center (SCC)	Mixer	Solvent Selection Valve
118	1	Yes	No	One time-programmed four-way valve
125	2	No	Yes	No
126	2	No	Yes	Two time-programmed four-way valves
127	2	Yes	Yes	No
128	2	Yes	Yes	Two time-programmed four-way valves

The SDMs are designed as part of the Beckman Coulter HPLC system using patented advances in technology. It utilizes a patented single piston, rapid refill design proven through years of dependable use. The micro-flow intelligent liquid head and digital stepper motor communicate to adjust motor speed to ensure that the system pressure after the refill cycle instantly returns to the column pressure measured during the delivery cycle. This real-time electronic compressibility compensation assures consistent, uniform, and pulse-free flow even under a variety of solvent and pressure conditions. The compressibility compensation is computer-controlled and automatic, requiring no user settings regardless of solvent conditions.

A dynamic mixer included in most modules provides the required mixing efficiency for high sensitivity chromatography with a minimum delay volume. Dynamic mixing offers the best compromise between minimum delay volume and maximum mixing efficiency. The dynamic mixer eliminates the possibility of baseline oscillations under a variety of chromatographic conditions (wavelength, sensitivity, physical characteristics of solvents, etc.). The proven check valve design operates dependably even at low flow rates.

The 125, 126, 127 and 128 pumps integrate two high-precision pump heads to deliver superior gradient precision with a wider range of mobile phases than static and low pressure mixing systems. The 118 SDM is a single pump head system.

The liquid heads are equipped with a piston wash feature which prevents the build up of crystallizing salts that can damage the piston and piston seals. The floating piston design also minimizes seal wear.

The SDMs are available in a variety of configurations designed to meet the various requirements of chromatographer. They are available with analytical liquid heads (up to 10 mL/min.), semi-preparative liquid heads (up to 30 mL/min.), and 4-way solvent selection valves (118, 126 and 128). Each of these configurations is available in a stainless steel or non-metallic format.

Time programmable solvent switching of up to eight solvents is an optional feature of the 126 and 128 SDMs which allows the automation of many chromatographic procedures. The 118 Solvent Delivery Module includes one solvent switching valve allowing up to four solvents. Each of the solvents can be selected in any order. This feature is useful in:

1. Automatic start up of a system. If the system and column are stored overnight in an appropriate solvent, the system can select the solvent for the analytical method, ramp up the flow, equilibrate and then signal the autosampler to start a series of injections.
2. Automated linking of methods. A series of analytical methods using different mobile phases can be linked to allow different series of samples to each be run with the appropriate conditions.
3. Automated step gradients. In several modes of chromatography, simple step changes in mobile phase composition can provide the required chromatographic resolution. The automatic solvent select valve can reproducibly deliver these step changes to the column.
4. Automatic column clean-up. After a method is run, it may be desirable to change to a flush solvent to wash the column, then change to an appropriate solvent for column storage. The automatic solvent select valve used in conjunction with flow programming makes automated column clean-up easy.
5. Automatic system shut-down. After completion of an analytical run, the operator may not be present to manually turn off the system. The ability to program a shut-down step facilitates unattended operation. Combining an automatic shut-down step with a subsequent start-up step the next morning can add productive hours to a chromatographer's day.

Model 166 Programmable UV/VIS Detector Module

The 166 Programmable Detector Module (PDM) is a variable wavelength UV/Vis HPLC detector designed as a part of the HPLC system software. The 166 has low noise and drift over a wide wavelength range. The 166 does not have conventional front panel controls, but is digitally controlled and monitored by either a computer with Beckman Coulter software or a 118, 127 or 128 Solvent Delivery Modules with System Control Center.

The 166 PDM communicates with the computer and 32 Karat Software via a two-way digital bus. The 166 PDM, like all Beckman Coulter HPLC modules, is intelligent, containing its own microprocessor and memory. The digital communication between the computer and the detector assures high accuracy, and allows the detector to send messages to the computer concerning its status. The detector output (absorbance values) is sent to the computer digitally, eliminating the need for analog to digital conversion. The detector also has analog outputs for connection to other data systems.

The 166 PDM optics contain a sealed monochromator with entrance slit, mirrors, diffraction grating, and grating drive mechanism. The monochromator is sealed to prevent light loss from dust particles in the air, to inhibit noise due to air currents, and to stop stray light. The monochromator is aligned at the factory so that the lamp assembly can be easily installed without adjustment.

The detector flowcell is designed to minimize band broadening as well as thermal and refractive index effects. Analytical and semi-preparative flowcells are available in both stainless steel and PEEK. The preparative and microbore flowcells are available stainless steel.

The 166 PDM operates within wavelength ranges of 190-700 nm with a UV (deuterium) source (using second order filters for visible range), and 360-700 nm with an optional visible (tungsten) source. The grating is positioned to the correct point by the digital stepper motor. A validated computerized algorithm is used to assure that the detector is in correct wavelength calibration.

Model 168 Programmable Diode Array Detector Module

The 168 Programmable Detector Module (PDM) is a diode array UV/Vis HPLC detector designed as a part of the HPLC system software. The 168 PDM does not have conventional front panel controls, but is digitally controlled and monitored by a computer running Beckman Coulter software.

The 168 PDM communicates with the computer and 32 Karat Software via a two-way digital bus. The 168 PDM, like all Beckman Coulter HPLC modules, is intelligent, containing its own microprocessors and memory. The digital communication between the computer and the detector assures high accuracy, and allows the detector to send messages to the computer concerning its status. The detector output (absorbance values) is sent to the computer digitally, eliminating the need for analog to digital conversion. The detector also has analog outputs for connection to other data systems.

The 168 PDM optics contain a sealed polychromator with mirrors, diffraction grating, and array. The polychromator is sealed to prevent light loss from dust particles in the air, to inhibit noise due to air currents and to stop stray light. The polychromator is aligned at the factory so that the lamp assembly can be easily installed without adjustment. The slit is an integral part of the flowcell.

The detector flowcell is designed to minimize band broadening as well as thermal and refractive index effects. Analytical, semi-preparative and microbore flowcells are all available in stainless steel.

By using a 512-element array, chromatographic and spectral data can be acquired at a rapid rate by reading the output from the various elements. The array is a series of closely spaced diodes fabricated in a line on a silicon crystal. The capacitance of each diode is charged during readout, and discharges as light strikes the diode. The amount of charge needed to recharge the capacitors is proportional to the light intensity at each diode. In the 168 PDM, each diode represents 1 nm. The bandwidth setting determines the number of diodes on each side of the specified wavelength which will be averaged to produce the signal.

In a diode array detector, resolution is limited not only by the number of diodes, but also by the ability of the optics to focus each wavelength onto a small spot on the array. The digital resolution of the 168 PDM is 1 nm and the optics and electronics combine to provide an optical resolution of 2 nm.

Because a large amount of data can be acquired at a rapid rate, there must be a sophisticated collection of electronic devices to support the optics. The 168 PDM uses three microprocessors: a 32-bit Motorola 68020 for control, an Intel 80C153 for data transmission, and a TI TMS320C25 DSP (digital signal processor) for data preprocessing.

Diode array detectors are commonly used to assess peak purity because of the additional information they provide compared to traditional single wavelength detectors. Scan comparisons, ratiograms, and visual analysis by 3D and isoabsorbance plots are all possible with the 168 PDM. Also included is a proprietary algorithm to assess peak purity using proven reliable mathematics. This provides an objective analysis of purity that does not rely on visual data interpretation. This is referred to as Real Time Purity or RTP.

The goal was to make peak purity information available in real-time, as the chromatogram elutes. This means that the calculations must be made while the detector is collecting, processing and sending data, in addition to controlling program changes and responding to user inputs, among other things.

However, this technique is calculation intensive; each new set of values can require more than 4300 calculations per second, depending on scan rate and wavelength range. To add these calculations to the tasks of the PC-based workstation would severely limit the types of computers which could be used. Thus, to achieve the performance required, the diode array detector described has three processors built into it to accomplish the required tasks.

The 168 PDM operates within wavelength ranges of 190-600 nm with a UV (deuterium) source. A validated computerized algorithm is used to assure that the detector is in correct wavelength calibration.

Injection Devices

Both manual and automated injection devices are available as part of the Beckman Coulter HPLC system. Available devices and some features are listed Table 2.

Table 2 Beckman Coulter Injection Devices

Device	Features
7725i Manual Sample Injection Valve	High pressure six-port rotary valve with sample loading through a built-in needle port in the front of the valve. The valve permits the injection of precise volumes of sample into the HPLC system. The valve also includes an event marker switch which is activated when the valve handle is moved from LOAD to INJECT position and is used to trigger the start of the chromatographic run.
502 Autosampler 507 Autosampler 507e Autosampler 508 Autosampler	All Autosamplers provide automated handling and injection of the sample. Some Autosamplers differ in how the sample volumes are obtained and these features are explained in the the appropriate Autosampler manual. Other Autosampler features are also explained in the appropriate manual.

Included with all Autosamplers is a comprehensive manual. This manual includes installation, operation and maintenance information. If you are installing an Autosampler as part of your system, please refer to this manual to install the Autosampler.

The manual part numbers for the Autosampler manuals are:

- 502 Autosampler (P/N 241087)
- 507 Autosampler (P/N 240651)
- 507e Autosampler (P/N 538794)
- 508 Autosampler (P/N 142494)

Basic Plumbing of the HPLC Modules

All pumps are preplumbed internally. The only external plumbing connections required are those to connect the pump's high pressure outlet line to the Autosampler or manual injector and the solvent line(s) to the solvent reservoir(s).

Typical plumbing configurations are shown in figure 2 below.

Figure 2 Plumbing Diagrams

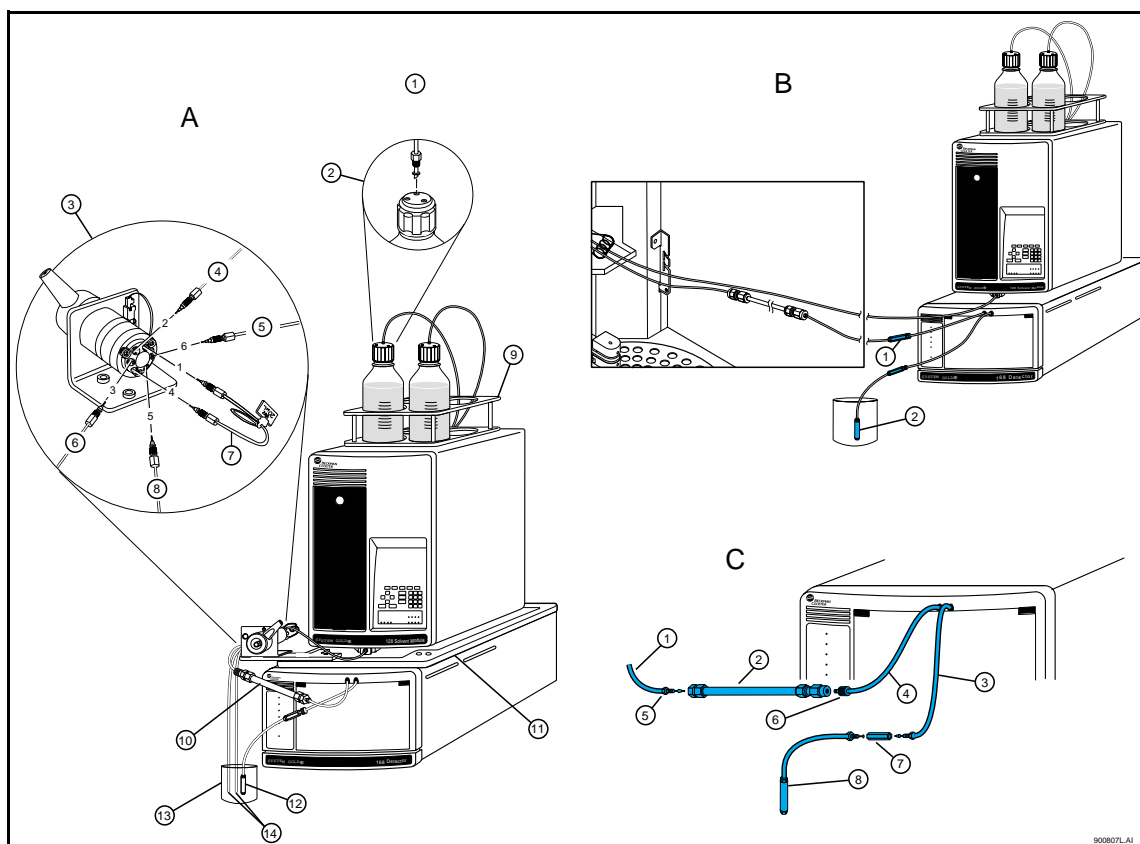

The configuration shown in detail A of figure 2 incorporates the 7725i Sample Injection Valve. The configuration shown in detail B incorporates an Autosampler. The configuration shown in detail C illustrates the fittings connecting the detector to the column and to the back pressure regulator. You should be able to identify in the illustrations the configuration applicable to your setup or one that is very close.

See the figure 2 legend on the next page for item descriptions.

Figure 2 Legend			
Callout	Description	Callout	Description
Detail A	Plumbing to 7725i Injection Valve	Detail B	Plumbing to 508 Autosampler
1	Refer to Installing Solvent Bottles details in Solvent Delivery Module section.	1	Union fitting
2	Bottle cap assembly	2	Back pressure regulator
3	Detailed view of 7725I Injection Valve	Detail C	Detailed view of fittings connecting detector to column and back pressure regulator
4	To pump high pressure outlet	1	To column port on injection valve
5	To waste container	2	Column
6	To column	3	Sample outlet line
7	Sample loop	4	Sample inlet line
8	To waste container	5	Stainless steel nut and ferrule
9	Bottle rack	6	Stainless steel nut and ferrule
10	Column	7	Union fitting
11	Drip tray	8	Back pressure regulator
12	Back pressure regulator		
13	Waste container		
14	Drain lines		

Pump Internal Plumbing

Figure 3 below shows the typical internal plumbing schematic.

Figure 3 Model 128 Pump Internal Plumbing

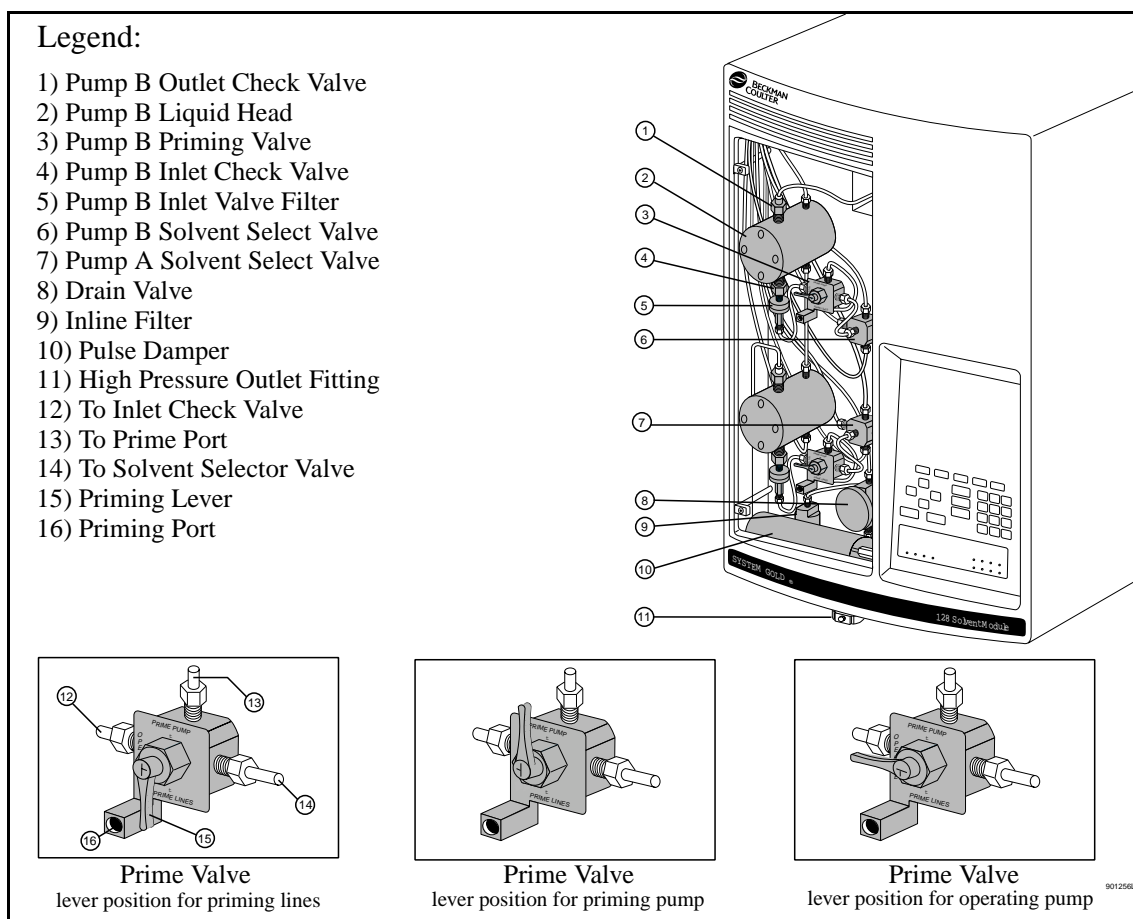

The previous pages have provided you with a brief introduction to the Beckman Coulter HPLC system hardware. The remainder of this User's Guide will cover operation of your HPLC system.

The Installation and Maintenance Manual included with your system covers many more features of the HPLC system including site preparation, installation, maintenance and troubleshooting.

Section 3 - Starting 32 Karat Software

To start the 32 Karat Software, select **Programs|32 Karat|32 Karat Software** from the Windows Start Menu button on the Windows Tool Bar.

Figure 4 Start Menu location for 32 Karat Software

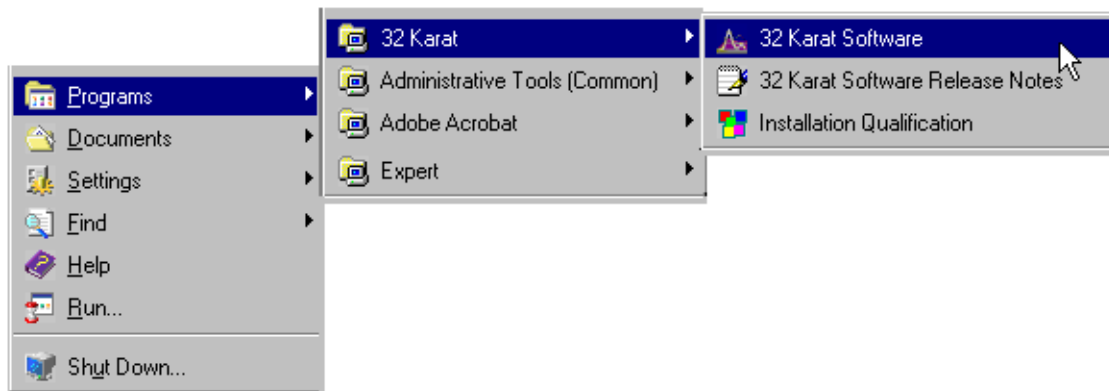

32 Karat Software opens to the current location / group window which lists the configured instruments.

Figure 5 32 Karat Software Enterprise Screen (The Main Menu)

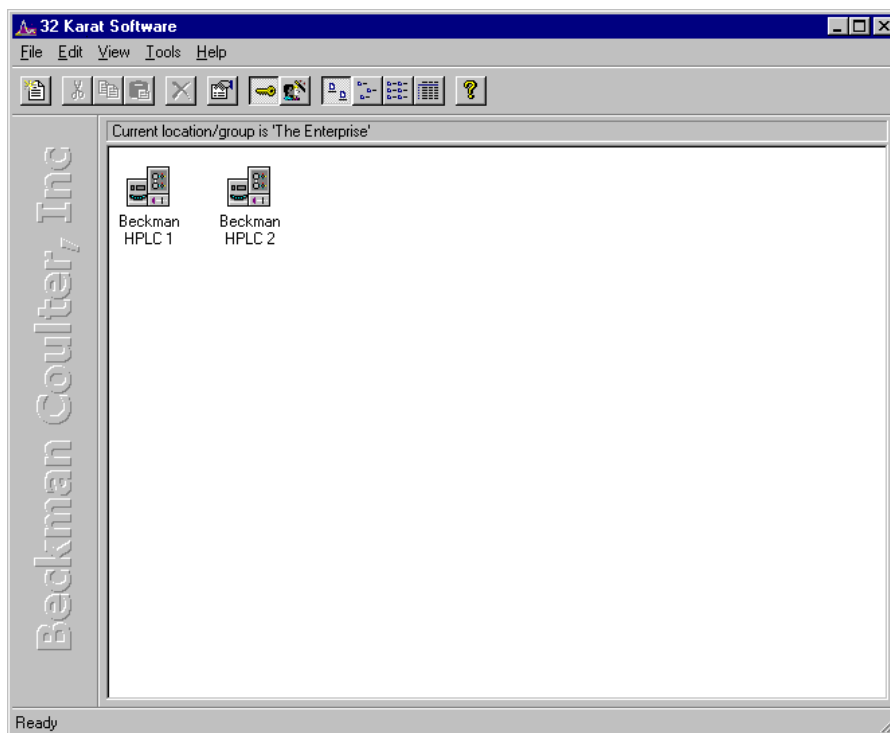

Tool Bar

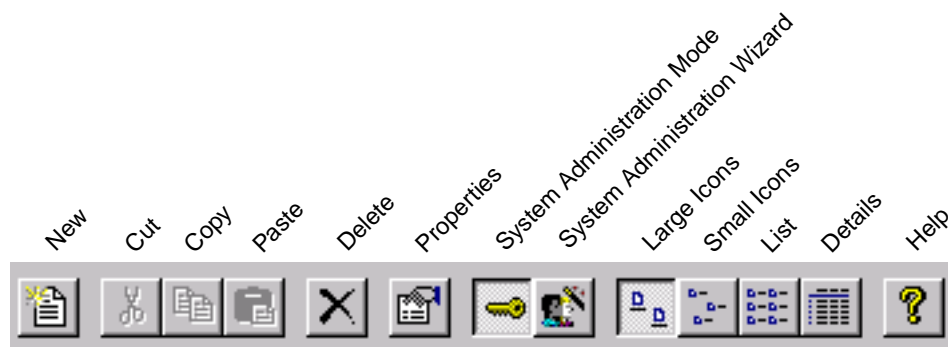

The Tool Bar appears at the top and, in some cases, the bottom of the active window. The active buttons within the Tool Bar allow for single mouse click access to many common commands. These buttons are available from the opening window.

Menu Bar

The Menu Bar contains all commands available in 32 Karat Software. The Menu Bar can be accessed by single mouse click or by holding down the Alt key and pressing the underlined letter.

Creating and Configuring an Instrument

In this exercise you will:

- create and configure an instrument for use with the tutorial exercises within this manual.

 NOTE	<p>This section assumes that all hardware and interface boards have been installed. If they have not been installed, please refer to the Installation and Maintenance Manual for instructions.</p>
---	--

Creating a New Instrument

Up to four Beckman HPLC's can be controlled from a single computer with 32 Karat Software (2 HPLC systems per Gold Board). An unlimited number of virtual instruments can be created for offline method editing or data analysis. Use the following exercise to configure a new instrument. Select the detector type(s) appropriate to your hardware configuration.

1. Right mouse click within the Enterprise Screen and select **New | Instrument** from the drop down menu.

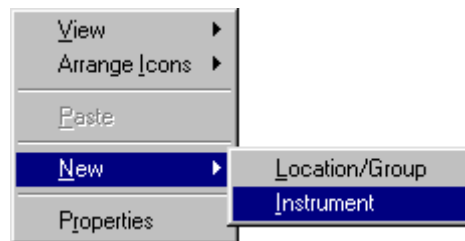

2. A new instrument will be created and an icon placed in the pane of the Enterprise Screen. You may enter the name of the instrument in the highlighted name field or in the next step of the configuration process. The instrument name will be used throughout 32 Karat Software, in the Instrument window, data reports, and the Instrument logs.

Notice

Additional information regarding Instrument Configuration parameters can be found in the 32 Karat Online Help.

Figure 6 32 Karat Software Enterprise Screen (The Main Menu) showing the newly created instrument

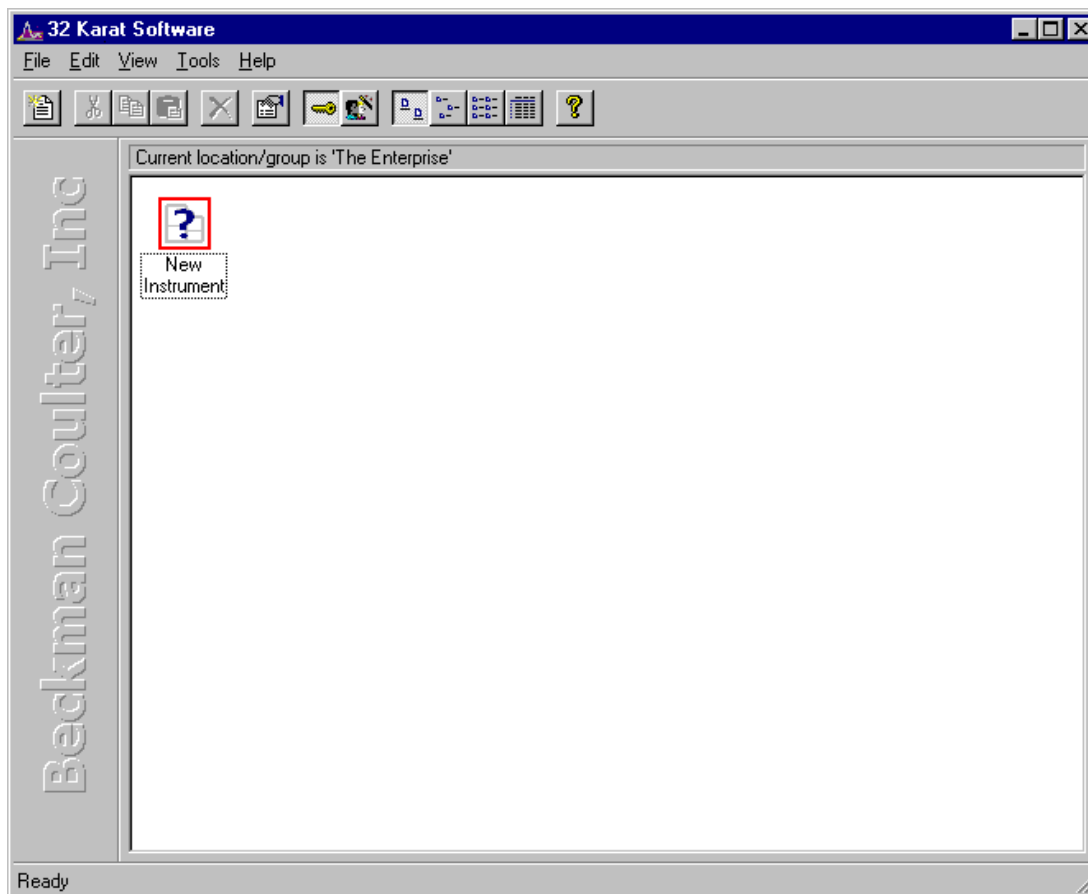

Configuring the New Instrument

Configuring the instrument is a process in which the software is prepared to control the hardware and process the data.

Instrument configuration consists of:

- identifying the HPLC as a unique instrument and
- identifying the hardware components that are present.

The following example will use a UV detector as a model.

1. Right mouse click on the New Instrument icon and select **Configure** from the drop down menu.

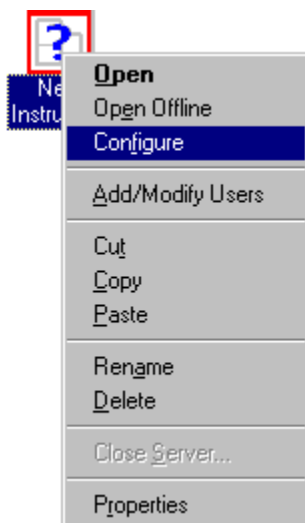

2. Select **Beckman HPLC System** from the *Instrument type* drop-down menu.
3. Input the name **“Tutorial Instrument”** in the *Instrument name* field to identify the instrument.

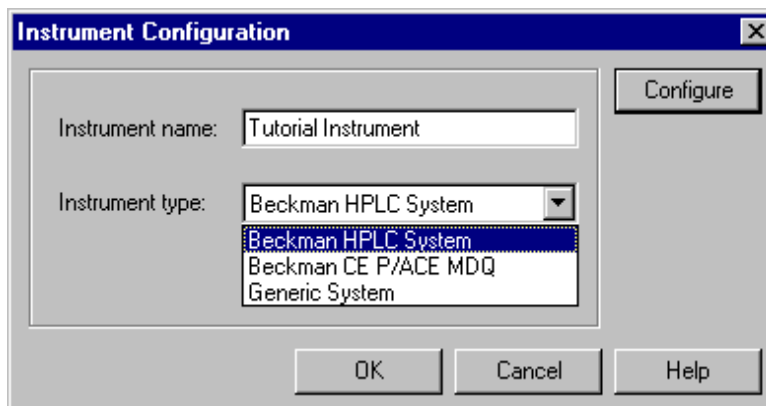

4. Click on the *Configure* button.

5. The Beckman HPLC System Configuration (Module Configuration) window is launched with the modules available for configuration listed in the left pane.

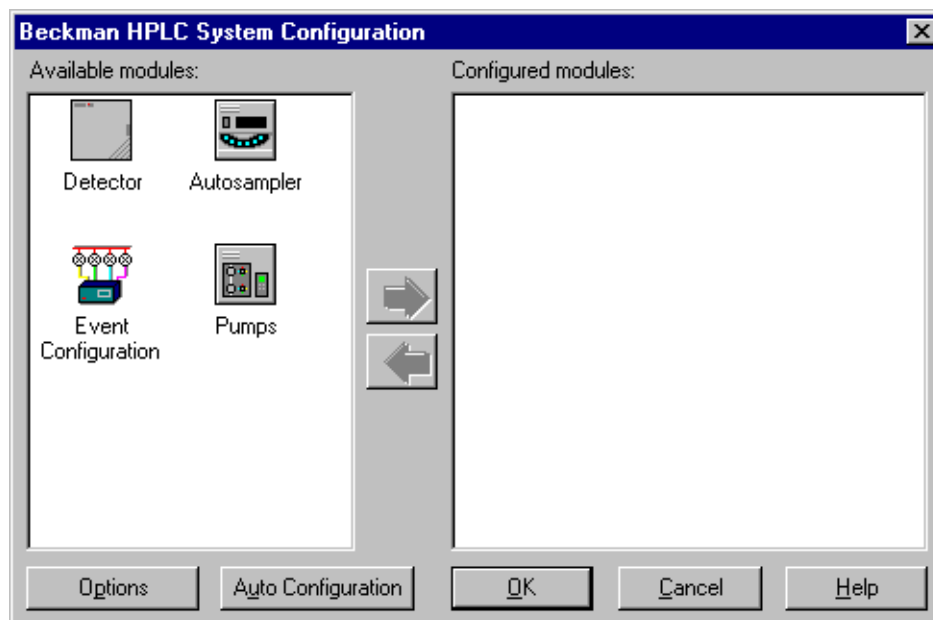

Auto Configuration

32 Karat Software can automatically configure all System Gold HPLC modules in the Instrument. This method of configuration is highly recommended when the Beckman HPLC modules are online. To do this, the instrument must be connected to the PC and turned ON.

1. Click the *Auto Configuration* button at the bottom of the Beckman HPLC System Configuration (Module Configuration) window.
2. The Gold Board Auto Configuration window will be displayed.

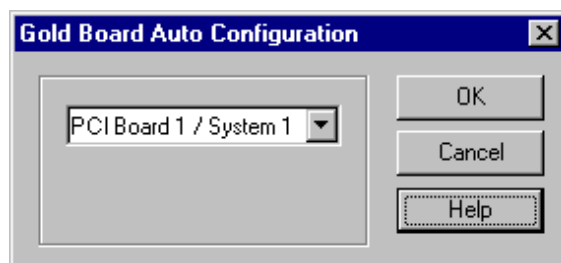

3. Select the Gold Board/System number to which your System Gold HPLC modules are connected and click OK.

- The Auto Configuration status window will be displayed indicating that the software is communicating with the instrument.

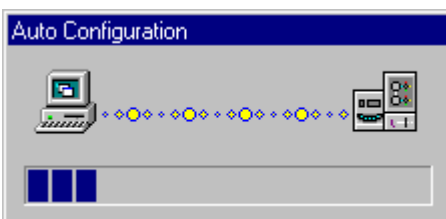

- When the Auto Configuration process is complete, all of the installed modules will be displayed in the Configured modules pane of the Beckman HPLC System Configuration (Module Configuration) window.

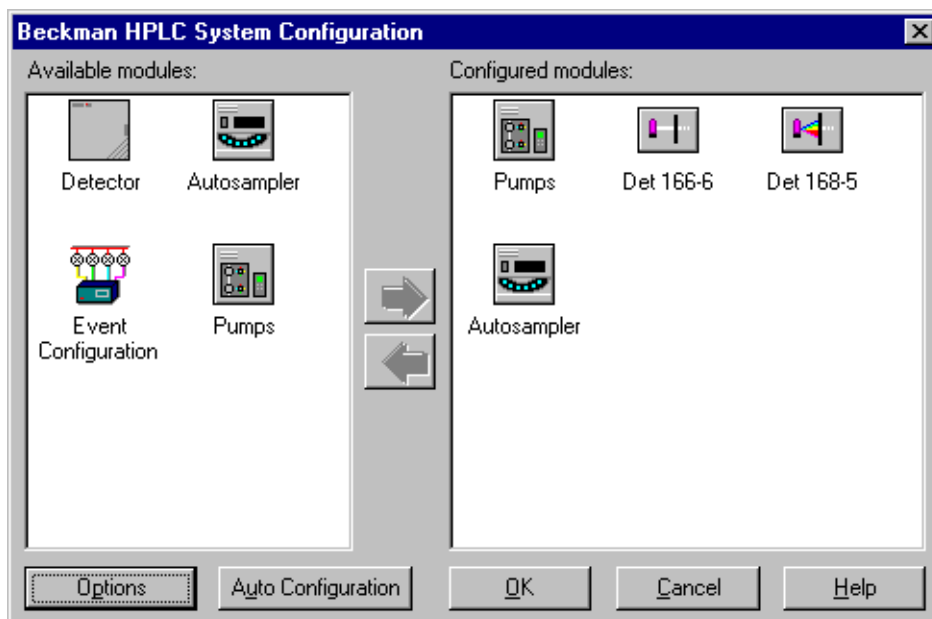

Notice

Analog detectors connected through the SS420 Board or SS420X Device must be manually configured.

For information on the **Manual Configuration** process, refer to the 32 Karat Online Help.

Additional Configuration Information

Detector Names

Because more than one detector can be configured in an Instrument, the detectors are given names so they can be distinguished from one another. These names appear in the Method edit windows, direct control and status dialogs, and printed reports. During Auto Configuration, 32 Karat Software will assign names to the Beckman Detectors configured to the Instrument based on the detector model number and bus ID. To assign the detectors names:

1. Double click the detector icon in the Configured Modules side of the window. You will be prompted with the Detector Configuration screen.

Figure 7 Detector Configuration screen

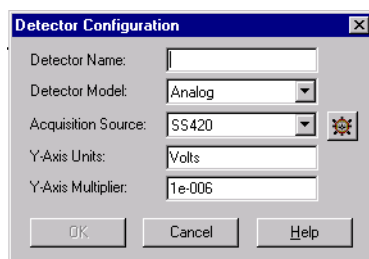

2. In the Detector Name field type a name. If you do not choose a name for the detector, the system will automatically name the detector as the detector type followed by the detector address (i.e. Det 166-6).

Figure 8 Detector Configuration screen with a 166 detector configured and the detector name assigned "Det 166-254".*

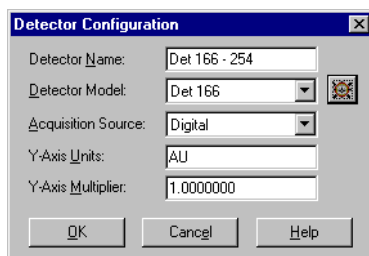

* The -254 following the Det 166 name in this example is an arbitrary naming convention and is meant to identify the wavelength at which the detector will be used in the tutorial.

3. Click on button next to “Detector Model” field to display the Detector 166 Configuration screen.

Figure 9 Detector 166 Configuration screen

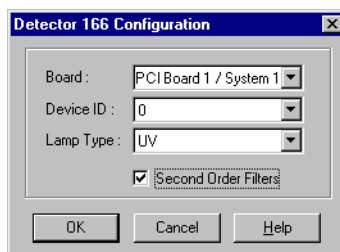

4. Click OK. The Beckman HPLC System Configuration (Module Configuration) window must be re-opened before a new detector name appears.

Figure 10 Beckman HPLC System Configuration window with the newly named detector. Also shown are the configured autosampler and pumps.

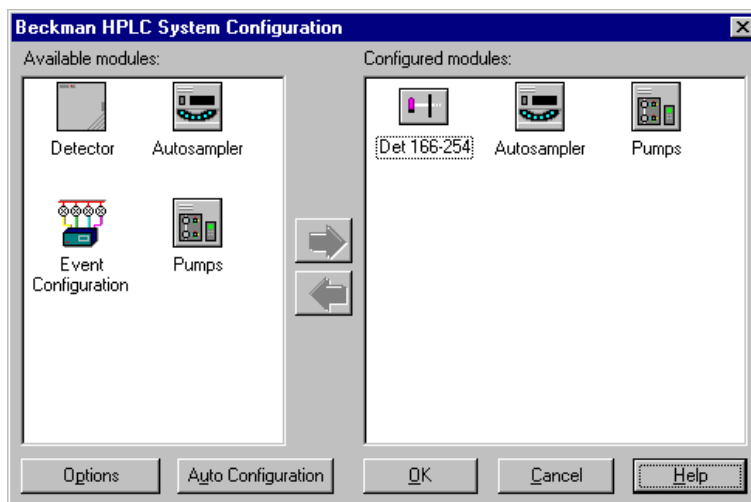

Notice

The Photo Diode Array (PDA) Detector (Model 168) is configured in the same manner as described above. To configure an Analog Detector, refer to the Online Help.

Verification of Pump Configuration

The Pump configuration parameters set during the Auto Configuration process can be found in the Pump Configuration window. To access this window, double-click on the Pumps icon in the configured modules pane of the Beckman HPLC System Configuration (Module Configuration) window.

Figure 11 Pump Configuration window.

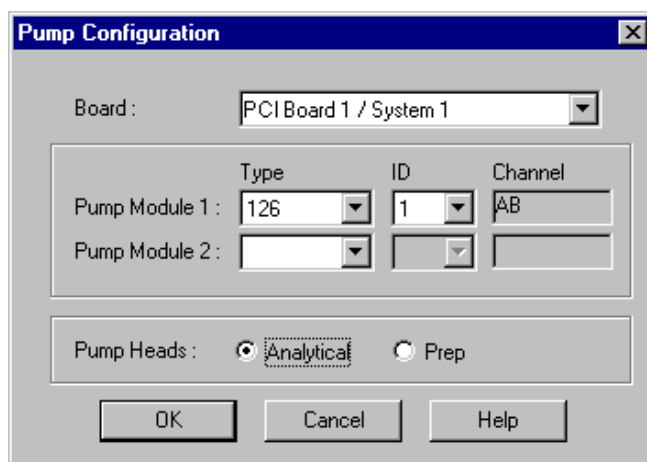

These parameters are set during the Auto Configuration process and should not be manually changed. More information on these parameters can be found in the 32 Karat Online Help.

Click OK to return to the Beckman HPLC System Configuration (Module Configuration) window

Verification of Autosampler Configuration

The Autosampler configuration parameters set during the Auto Configuration process can be found in the Autosampler Configuration window. To access this window, double-click on the Autosampler icon in the configured modules pane of the Beckman HPLC System Configuration (Module Configuration) window.

Figure 12 Autosampler Configuration screen with a model 502 autosampler selected.

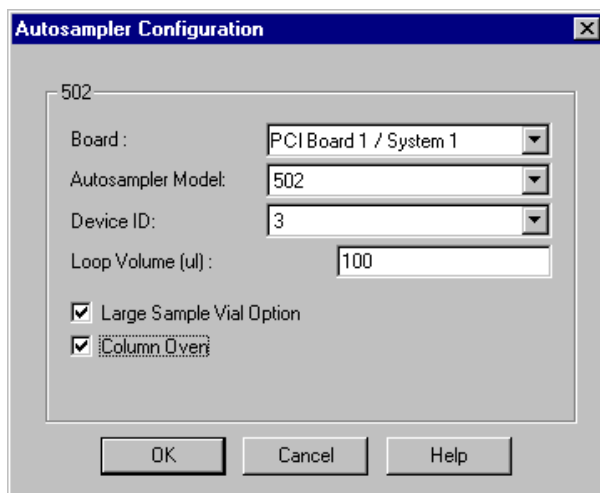

Figure 13 Autosampler Configuration screen with a model 507 autosampler selected.

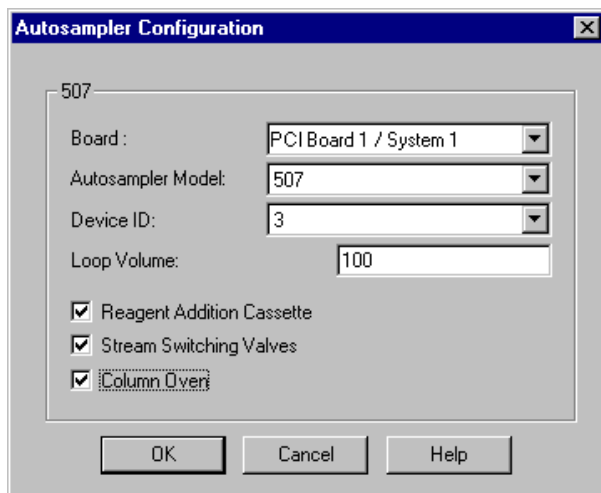

Figure 14 Autosampler Configuration screen with a model 507e autosampler selected.

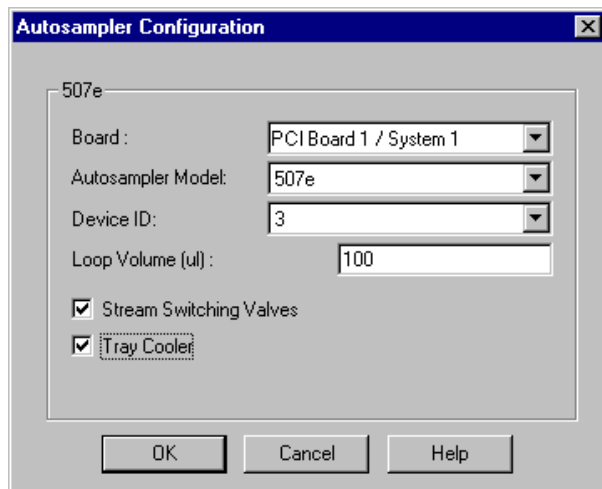
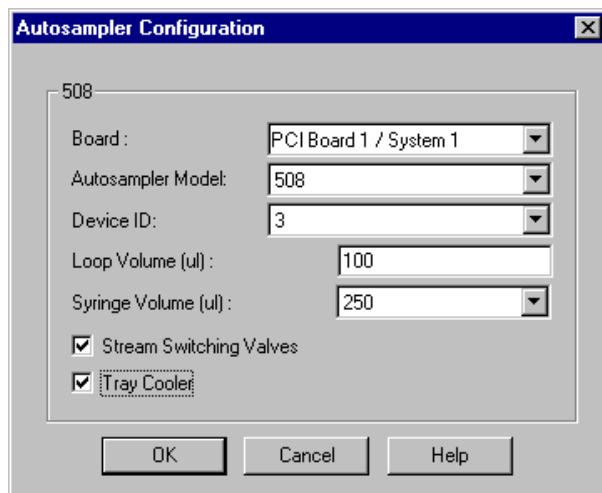

Figure 15 Autosampler Configuration screen with a model 508 autosampler selected.



These parameters are set during the Auto Configuration process and should not be manually changed. More information on these parameters can be found in the 32 Karat Online Help.

Click OK to return to the Beckman HPLC System Configuration (Module Configuration) window

Once you have completed the Auto Configuration process, named your detector and verified the configuration parameters of any other modules connected to your instrument, click OK to return to the Instrument Configuration (identification) window.

Click OK again to return to the 32 Karat Enterprise Screen (the Main Menu).

Figure 16 32 Karat Enterprise Screen (The Main Menu) with “Tutorial Instrument” configured.

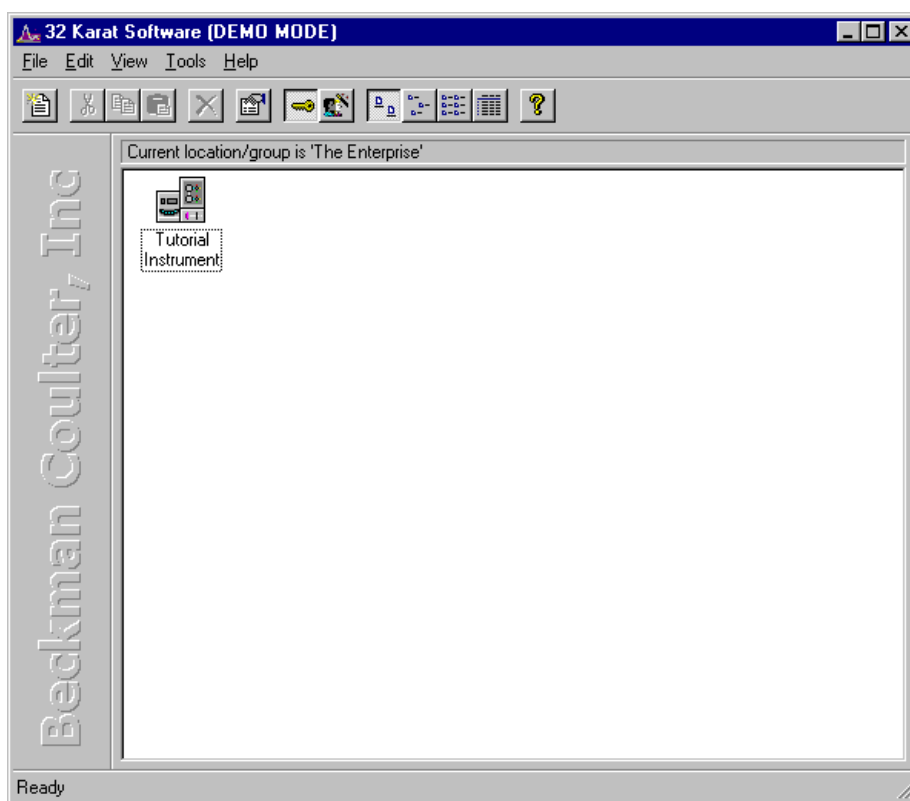

The newly configured instrument should appear in the Enterprise Screen as an icon with the name “Tutorial Instrument” below.

To use the instrument, double click on the instrument icon.

You have completed the Getting Started and Configuration section of the User's Guide.

Section 4 - Direct Control



Introduction

The Direct Control screen is essentially the front panel of the instrument. It allows you to select and change operating parameters with immediate execution. Direct Control is useful in preparing for Operations, Maintenance and Troubleshooting.

The Direct Control screen is used to control the instrument by mouse clicking on “hot” areas of the window. These areas either activate the associated dialog box - allowing modification of the instrument settings - or activate the task directly. The Direct Control screen displays service messages which show current instrument activity and instrument status in real time.

Notice

Additional information regarding Direct Control features can be found in the 32 Karat Online Help.

Direct Control Window

To access the Direct Control window, go to the Control Menu and select **Direct Control**.

Figure 17 Hot spots and “read only” display parameters in the Direct Control window

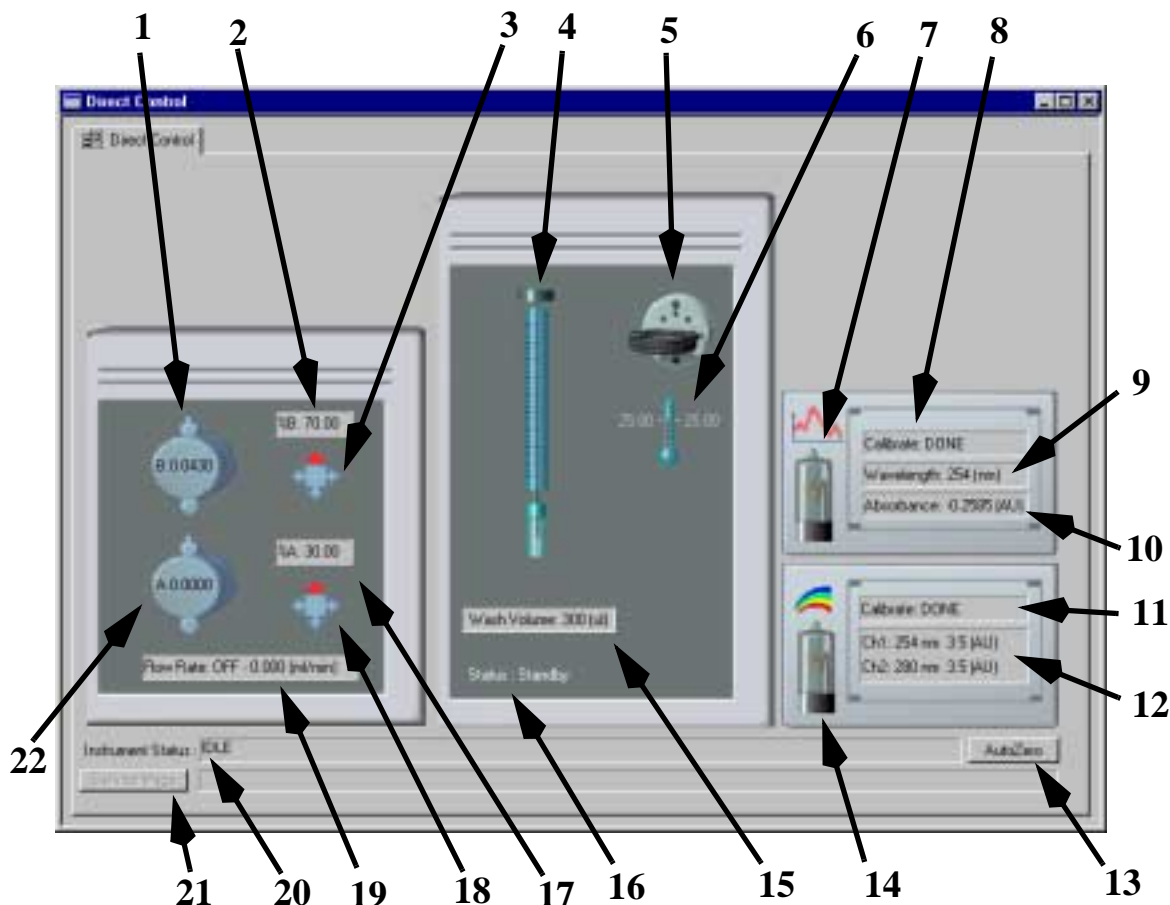

1	Pressure Reading (Pump B)	12	PDA Detector Channel Settings
2	Solvent Composition Percent (Pump B)	13	Detector AutoZero
3	Solvent Selection Valve (Pump B)	14	PDA Detector Deuterium Lamp On/Off Switch
4	Needle Wash	15	Wash Volume Settings
5	Injection Valve	16	Autosampler Status (read only)
6	Tray Cooling Temperature Settings	17	Solvent Composition Percent (Pump A) (read only)
7	UV Lamp On/Off Switch	18	Solvent Selection Valve (Pump A)
8	UV Detector Calibration	19	Flow Rate Settings
9	UV Detector Wavelength Selection	20	Instrument Status Dialog (read only)
10	UV Detector Absorbance Display (read only)	21	Service Message Dialog (read only)
11	PDA Detector Calibration	22	Pressure Reading (Pump A)

The appearance of the Direct Control Screen depends upon the particular instrument configuration. The functions are defined in Table 3.

Table 3 Direct Control Functions

CONTROL FUNCTIONS IN DIRECT CONTROL		
Pump Settings	Pressure	Opens dialog to set the pressure limits for the selected pump
	Composition	Opens dialog to set the solvent composition (%B)
	Solvent Selection	Switches valve positions for solvent selection as indicated by the direction of the highlighted arrow
	Flow Rate	Opens a dialog to set the flow rate
Detector Settings	Calibrate	Initiates the calibration procedure for the selected detector
	Lamp Status	Opens dialog allowing lamp(s) to be toggled on/off
	Autozero	Adjusts the detector's output to zero
	Wavelength	Opens dialog to set the wavelength for the UV detector
	Channels	Opens dialog to set the wavelength and bandwidth for each channel of the PDA detector
Autosampler Settings	Inject	Opens dialog to initiate injection of sample into the column
	Wash	Initiates the needle washing procedure
	Wash Volume	Opens a dialog to input to volume of solution to be used in the needle washing procedure
	Tray Temperature	Opens a dialog to set the temperature for the Autosampler tray ring (models 507e & 508 only)

All direct control functions are available via "hot spots". When the mouse cursor passes over a hot spot, a popup note will appear explaining the nature of the control. When a hot spot is clicked, a control dialog will open if a value can be changed.

Section 5 - Creating and Editing a Method

Introduction

This section will describe the basic steps in creating an instrument method for data analysis and will familiarize the user with the Instrument window of 32 Karat Software. This includes creating and editing a method.

The objectives of this exercise are to:

- Open the Instrument window.
- Create a method for a configured instrument.
- Edit that method.
- Run a sample using the 3 component Q.C. test mix (P/N 238447).
- Save the data on hard disk.

There are many more features, such as data analysis and reporting, that can be incorporated into a method. Some of these are covered later in this manual. For more information, see Appendix 1 or the Online Help.

Creating a Method

The following sections describe how to create a method with 32 Karat Software. Since the appearance of the method programming windows is based on the Instrument configuration, the following sections are divided by HPLC module type. The sections include:

- Isocratic Methods
- Gradient Methods
- PDA Methods
- The Injector Tab
- Saving a Method
- Editing a Method

Isocratic Methods

This section describes how to create a simple isocratic method to run the Q.C. test mix with a 166 detector, on the test column shipped with your system.

1. To create or edit a method you must be in an Instrument window. To open this window, go to the 32 Karat Enterprise Screen. Right click on the “Tutorial Instrument” you created in Section 3 and select *Open*, or simply double click on the instrument icon.

Figure 18 Opening the “Tutorial Instrument” from within the 32 Karat Enterprise Screen (the Main Menu)

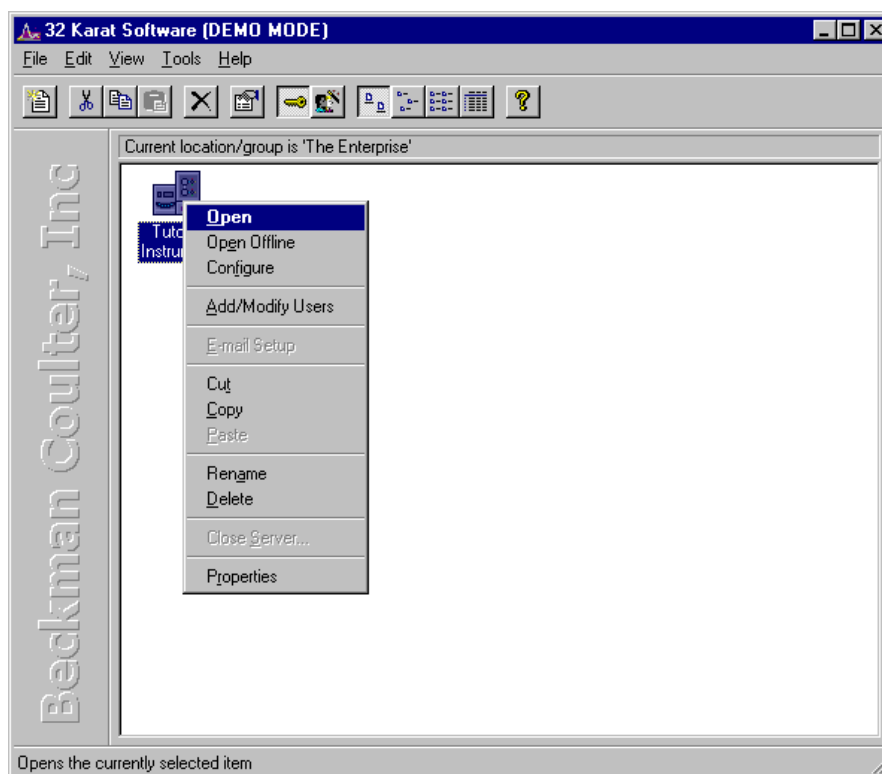

2. The Instrument window will open after a few seconds.

Notice

All method editing, data collection, data analysis and report generation is done within the Instrument window.

- When the window opens, the Instrument Wizard window will appear. It is possible to open the method editing dialogs by selecting *Create or Modify a Method* from this dialog. For now, just click *OK* to close the Instrument Wizard.

Figure 19 The Tutorial Instrument's Instrument window displaying the Instrument Wizard window

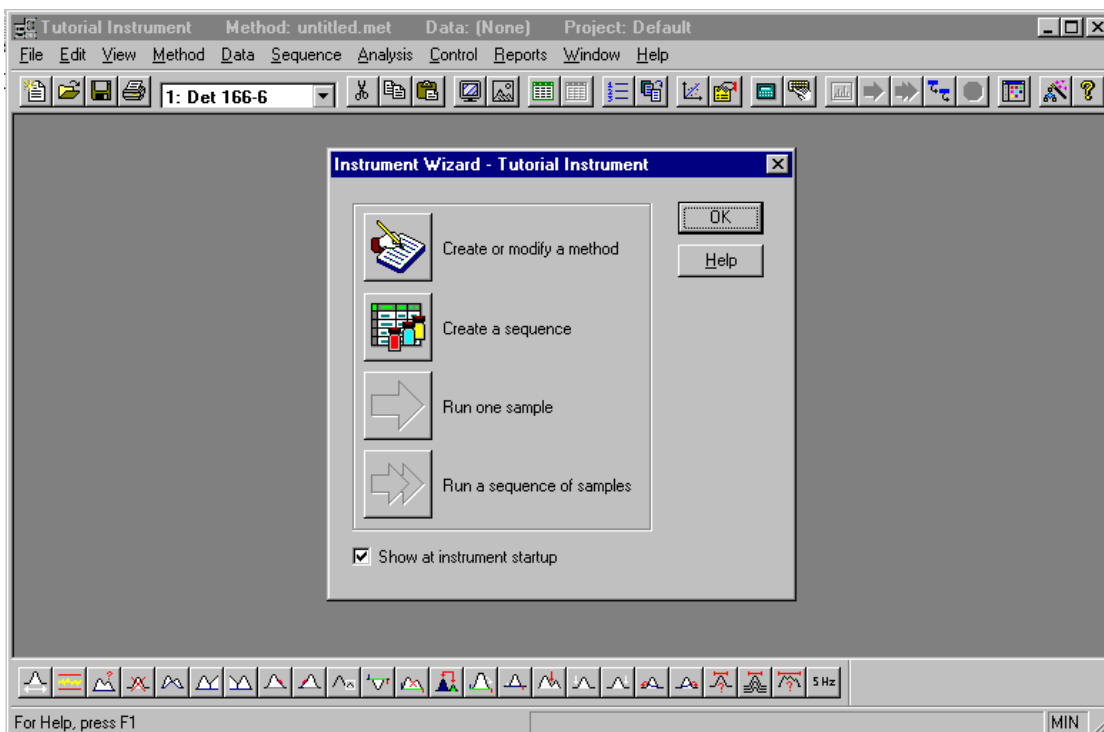

- From the Method menu, select Instrument Setup. You can also access the Instrument Setup window by simply clicking the Instrument Setup icon located on the toolbar or by pressing the *Ctrl + Shift + F2* keys.

Figure 20 Instrument Setup icon (left) / Instrument Setup menu selection (right)

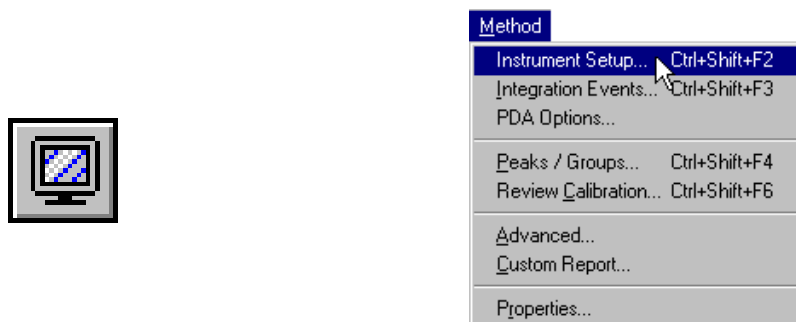

5. The appearance of the Instrument Setup window is based on the instrument's configuration, with an Initial Parameters tab for each module configured and a Time Program tab.

Figure 21 Instrument setup window with tabs for Time Program, 126 Pump, Det 166-254, 508 Autosampler and Aux Traces.

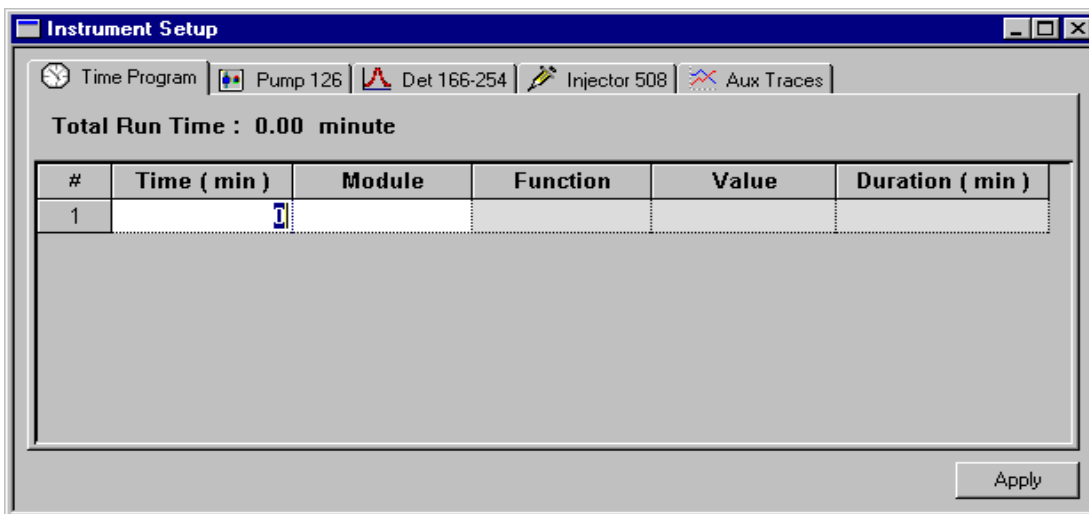

Pump Initial Parameters tab

6. Select the Pump Initial Parameters tab and make the following settings to match those shown in the figure below:
7. Enter a Flow Rate of 1.0 ml/min.
8. Enter a Duration of 0.50 min.
9. Set the %B composition to 70%. The %A composition will be automatically set based on the %B.
10. Set Re-equilibration to 0.00 min.
11. Set the Upper Limit for Pressure to 4.000 KPSI (4000 psi).

Notice

These settings assume a 15 cm column (rated at 4000 psi maximum) and analytical system.

12. In the Solvent Select frame, you may type in the names of the solvents next to the A1 and B1 fields.
13. Leave all other settings in this window in their default values for now.

Figure 22 Pump Initial Parameters tab.

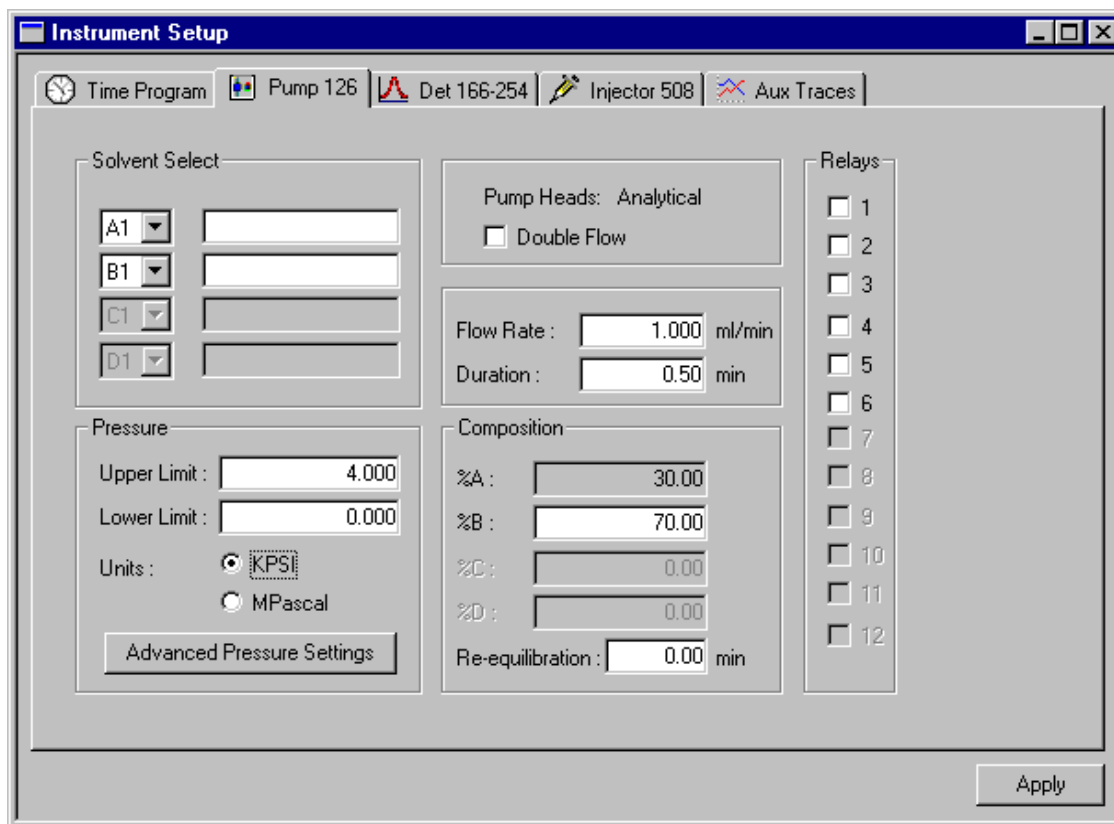

Detector Initial Parameters tab

14. Select the Det 166-254 Initial Parameters tab (the name on this tab is the name given to this detector in the configuration dialog).
15. If you are using a PDA Detector, see the PDA methods section of this manual.
16. Make the following settings to match those shown in the figure below:
17. Select the “Acquisition Enabled” option.
18. Select the “Auto Zero” option so that the detector output is automatically “zeroed” when this method is downloaded.
19. Select a Data Rate of 1 Hz.
20. Enter 254 nm for Wavelength. This is why the detector was assigned the descriptive name of Det 166-254.
21. Leave all other settings in this window in their default values for now.

Figure 23 UV Detector “Det 166-254” Initial Parameters tab.

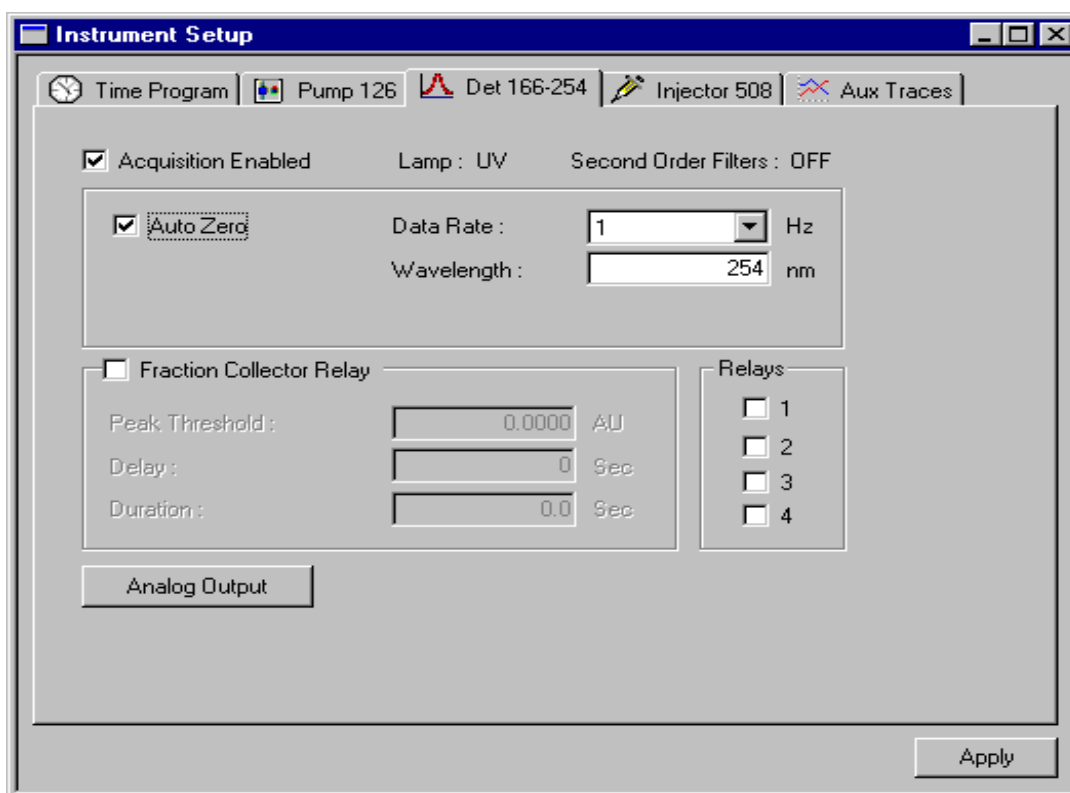

Time Program tab

22. Select the Time Program tab.

Figure 24 Time Program tab.

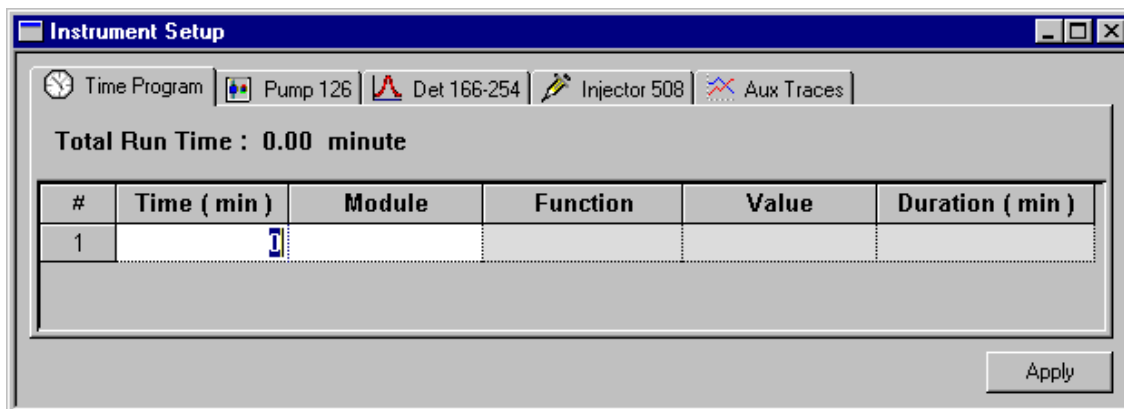

23. Enter 0.00 in the Time column.
24. Press the Tab key to move to the Module column.
25. Click on the down arrow located at the right of the Module column.
26. The contents of the drop-down menu in the Module column will reflect the Instrument configuration.

Figure 25 Time Program tab showing the Module drop-down menu.

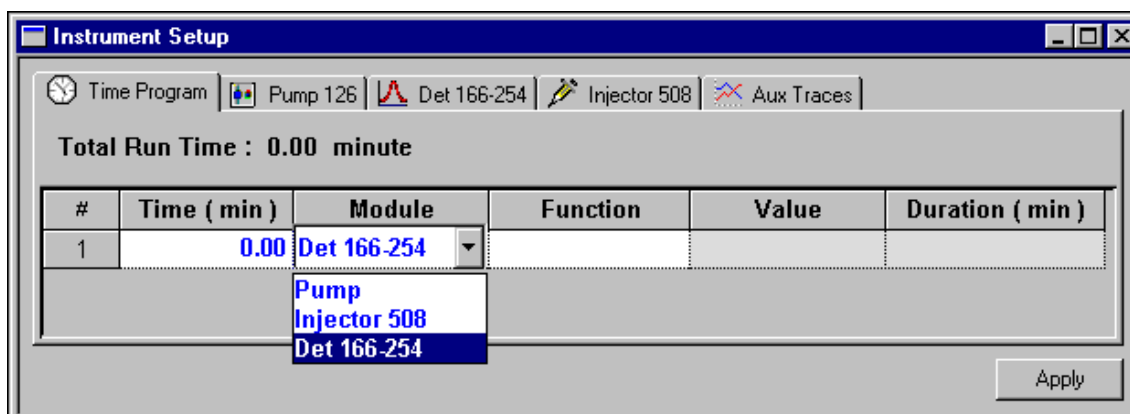

27. Select the 166 Detector (Det 166-254) option from the drop-down menu.

28. Press the Tab key to move to the Function column.
29. Click on the down arrow located at the right of the Function column.
30. The contents of the drop-down menu in the Function column will reflect the selection made in the module column.
31. Select Autozero from the drop-down menu. This will automatically “autozero” the detector at the start of data collection.

Figure 26 Time Program tab showing the Function drop-down menu.

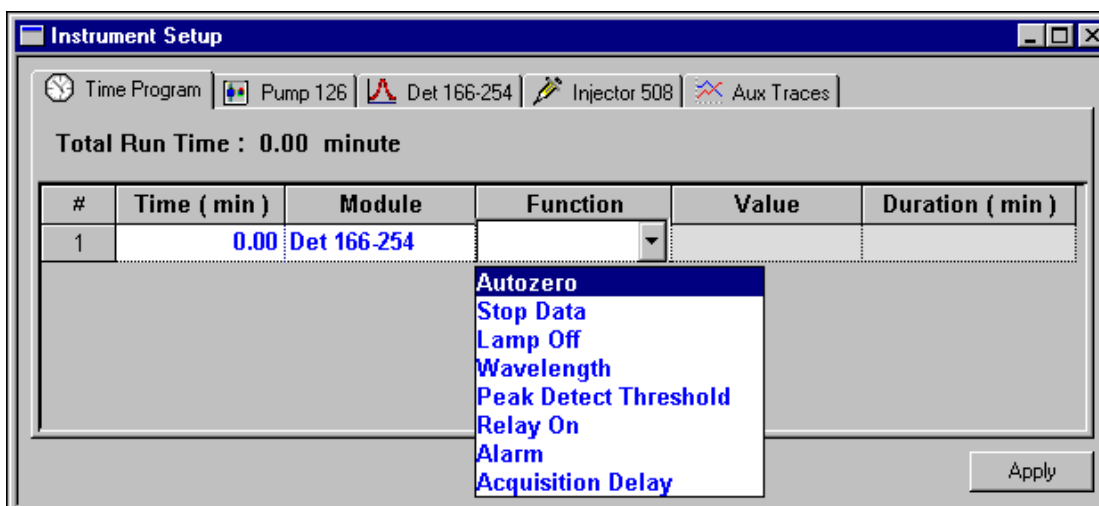

32. This function does not require an entry in the Value or Duration column.

33. In line 2, enter 4.00 in the Time column.
34. Press Tab to move to the Module column.
35. Click on the down arrow located at the right of the Module column, and select the 166 Detector (Det 166-254) from the drop-down list.
36. Press Tab to move to the Function column.
37. Select Stop Data in the Function column.
38. The method end time is automatically calculated by 32 Karat Software - based on the last timed event.
39. The Time Program window on your computer should look like the following:

Figure 27 Time Program tab with the Time Program lines.

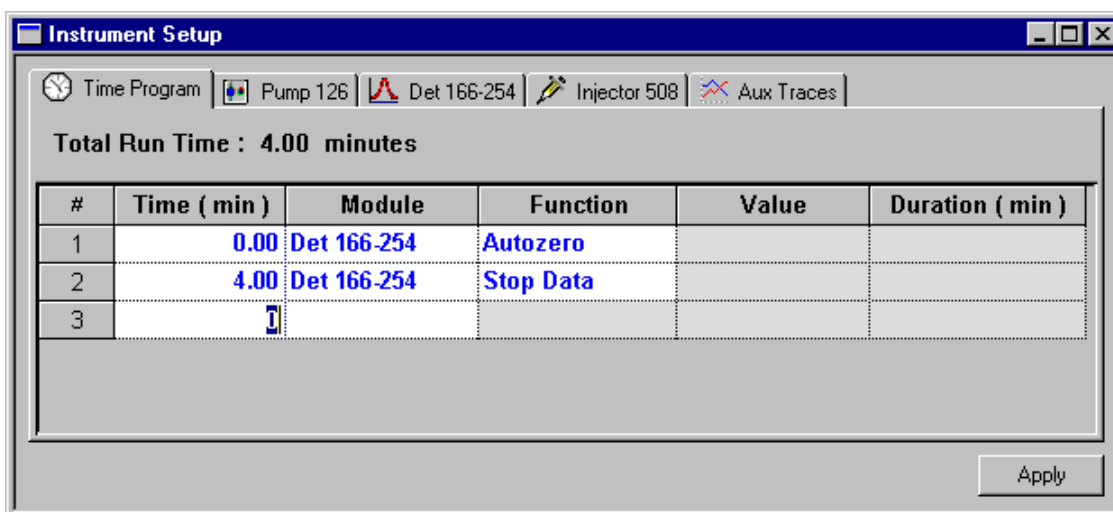

To finish creating your method, you must set the parameters located under the Injector tab.

The Injector Tab

All Instrument configurations require an injector to trigger the start of a method. There will always be an Injector tab in the Instrument setup window. However, this tab will change to reflect the injector type configured to your system.

Manual Injector

When a manual injector is installed on the Instrument the tab will be titled “Injector” and will appear as below:

Figure 28 Injector tab - Manual Injector configured.

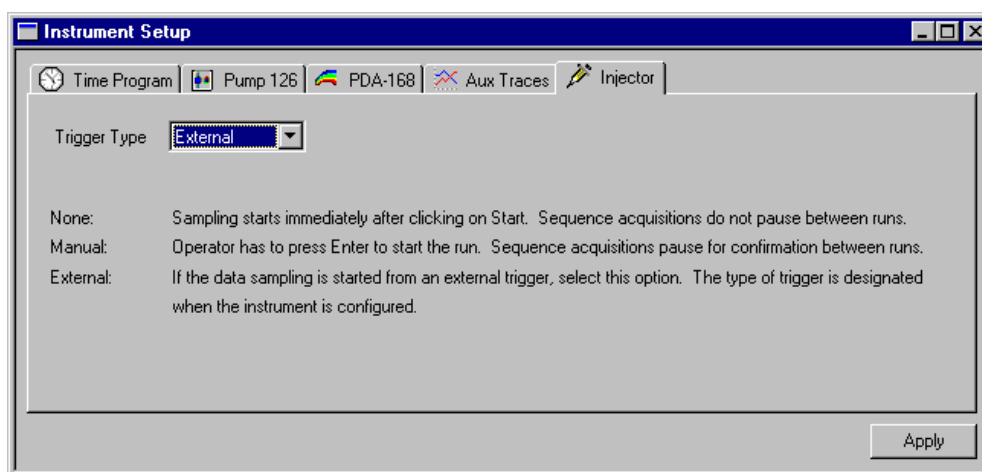

If the manual injector is supplied by Beckman Coulter and has been installed with Remote Interface cables, select External as the Trigger Type. The remote interface cables conduct a contact closure when the valve is rotated from the Load to the Inject position that will trigger the start of a method.

If the manual injector is not supplied by Beckman or has not been installed with remote interface cables, select Manual as the Trigger Type. When this Trigger Type is selected - a method is started, the Initial Parameters are downloaded, and a Manual trigger “start” dialog box opens. Rotate the valve from the Load to the Inject position and simultaneously click the OK check box (or hit the enter key) to begin data collection.

Notice

Additional information regarding the selections available for the various types of injector modules can be found in the 32 Karat Online Help.

Autosampler

If a Beckman Autosampler is configured (a model 502, 507, 507e, or 508) the Injector tab will include the autosampler model number in the title and the programmable parameters on the tab.

On the 508 Autosampler tab, select External as the Trigger Type and select Wash Between Vials.

Set the Tray Configuration to match the configuration in your Autosampler.

When a method is started, the autosampler will perform its injection routine, then automatically rotate its valve from the load to the inject position - starting data collection. You are now ready to save the method.

Refer to the Online Help for more information regarding the Autosampler.

Figure 29 Injector tab - Autosampler configured

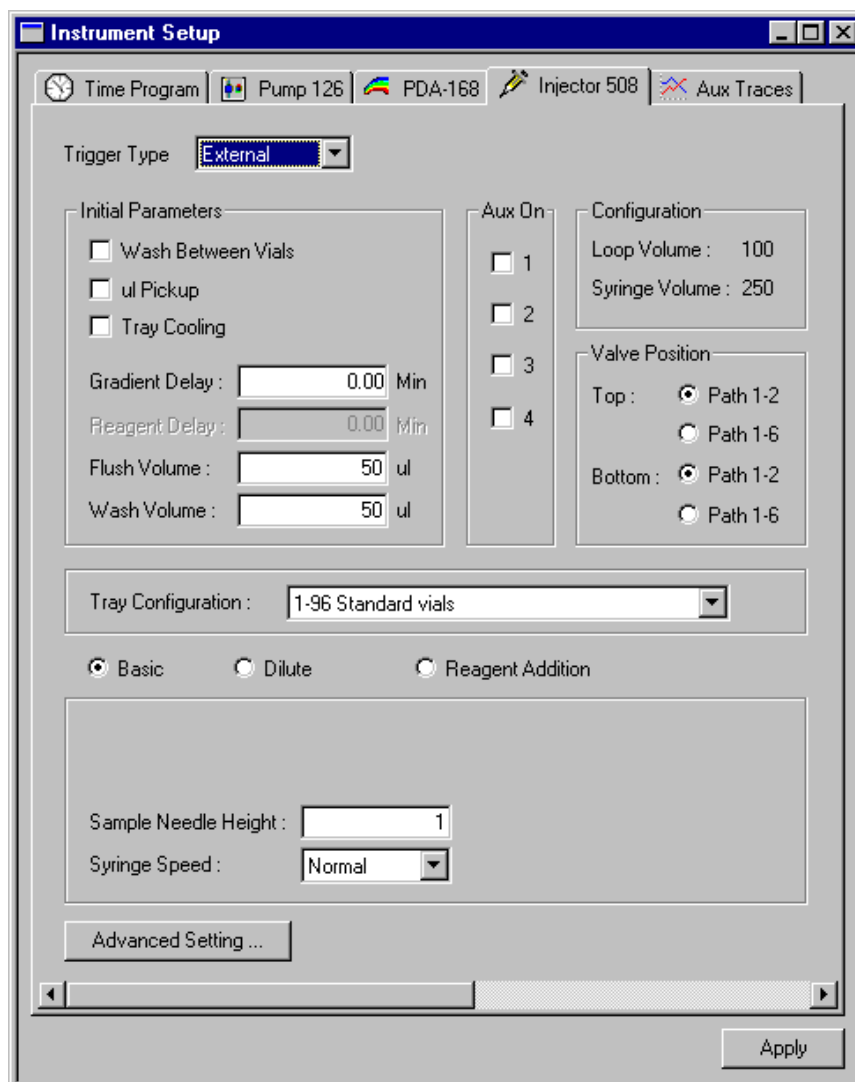

Saving a Method

When the method has been completed from the above sections it must be saved.

1. From the File menu, select Method/Save As.
2. Type "Tutorial Isocratic" in the File Name field and select the directory in which to save the method.
3. Click on Save.

Figure 30 Saving the Method file.

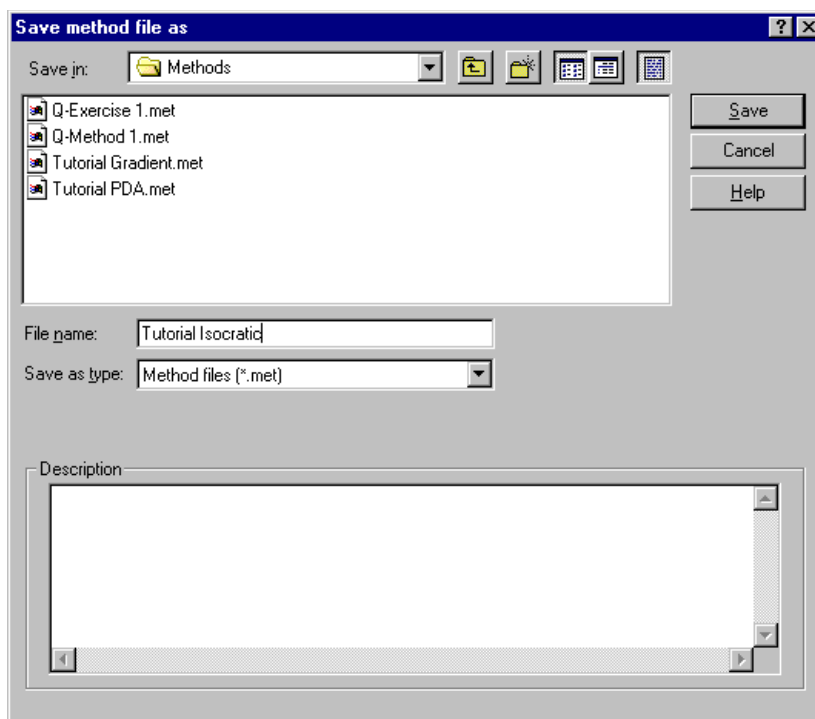

Close the Time Program screen by clicking on the 'X' in the upper right-hand corner.

There are many more functions that 32 Karat Software can perform during a method. This is the minimum amount of information that 32 Karat Software needs to run a sample.

Gradient Methods

This section describes how to create a simple isocratic method to run the Q.C. test mix with a 166 detector, on the test column shipped with your system.

1. To create or edit a method you must be in an Instrument window. To open this window, go to the 32 Karat Enterprise Screen. Right click on the “Tutorial Instrument” you created in Section 3 and select *Open*, or simply double click on the instrument icon.

Figure 31 Opening the “Tutorial Instrument” from within the 32 Karat Enterprise Screen (the Main Menu)

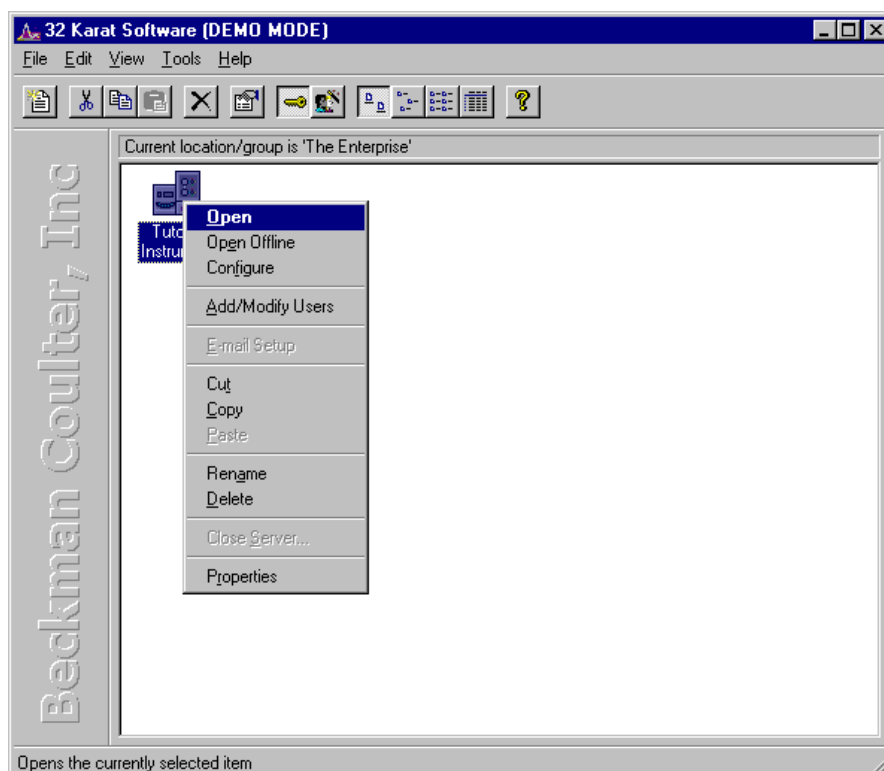

2. The Instrument window will open after a few seconds.

Notice

All method editing, data collection, data analysis and report generation is done within the Instrument window.

- When the window opens, the Instrument Wizard window will appear. It is possible to open the method editing dialogs by selecting *Create or Modify a Method* from this dialog. For now, just click *OK* to close the Instrument Wizard.

Figure 32 The Tutorial Instrument's Instrument window displaying the Instrument Wizard window

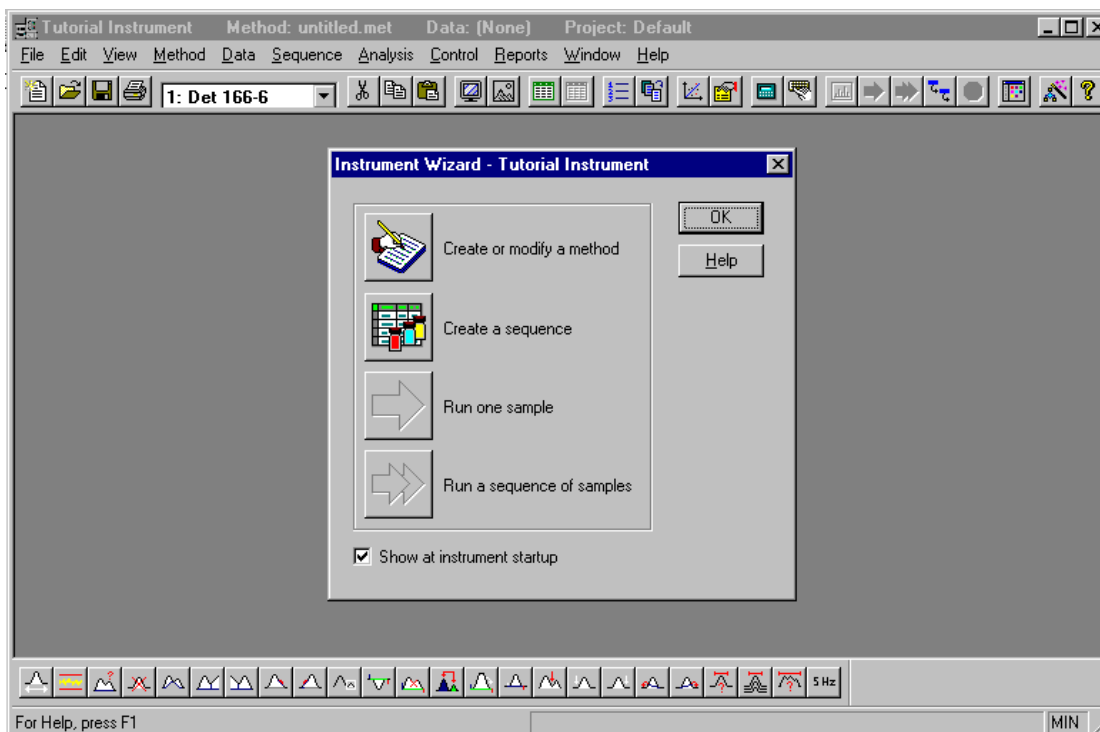

- From the Method menu, select Instrument Setup. You can also access the Instrument Setup window by simply clicking the Instrument Setup icon located on the toolbar or by pressing the *Ctrl + Shift + F2* keys.

Figure 33 Instrument Setup icon (left) / Instrument Setup menu selection (right)

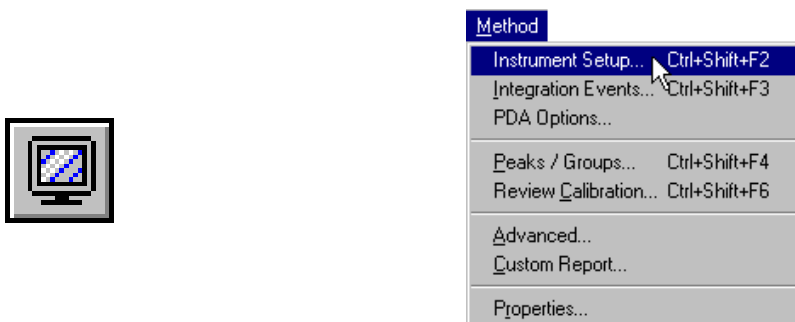

- The appearance of the Instrument Setup window is based on the instrument's configuration, with an Initial Parameters tab for each module configured and a Time Program tab.

Figure 34 Instrument setup window with tabs for Time Program, 126 Pump, Det 166-254, 508 Autosampler and Aux Traces.

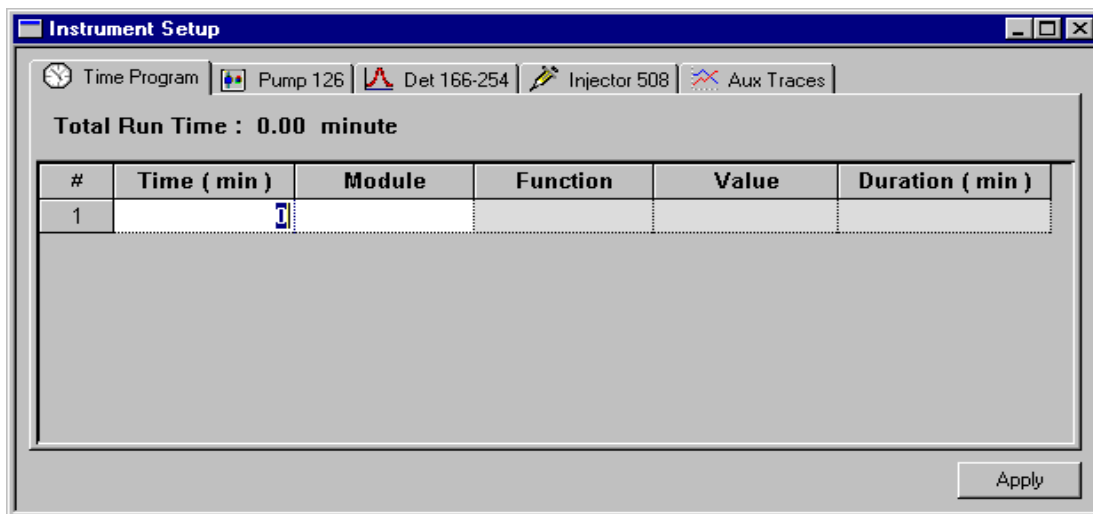

Pump Initial Parameters tab

6. Select the Pump Initial Parameters tab and make the following settings to match those shown in the figure below:
7. Enter a Flow Rate of 1.0 ml/min.
8. Enter a Duration of 0.50 min.
9. Set the %B composition to 60%. The %A composition will be automatically set based on the %B.
10. Set Re-equilibration to 0.00 min.
11. Set the Upper Limit for Pressure to 4.000 KPSI (4000 psi).

Notice

These settings assume a 15 cm column (rated at 4000 psi maximum) and analytical system.

12. In the Solvent Select frame, you may type in the names of the solvents next to the A1 and B1 fields.
13. Leave all other settings in this window in their default values for now.

Figure 35 Pump Initial Parameters tab.

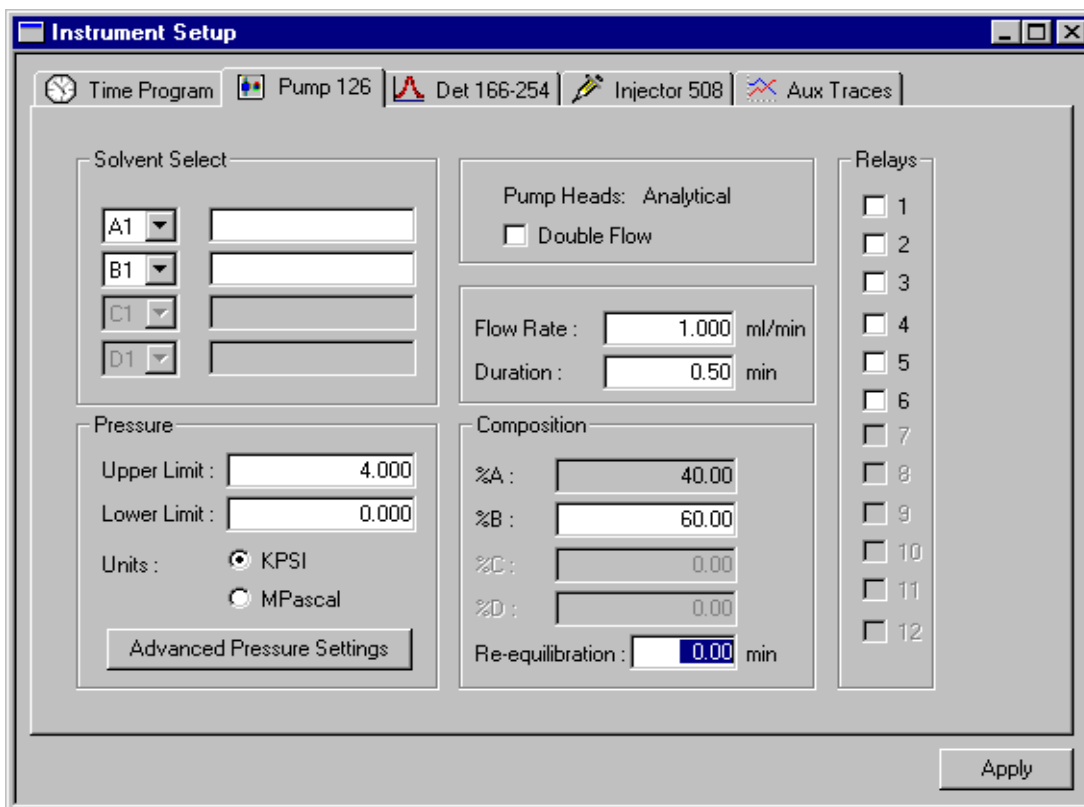

Detector Initial Parameters tab

14. Select the Det 166-254 Initial Parameters tab (the name on this tab is the name given to this detector in the configuration dialog).
15. If you are using a PDA Detector, see the PDA methods section of this manual.
16. Make the following settings to match those shown in the figure below:
17. Select the “Acquisition Enabled” option.
18. Select the “Auto Zero” option so that the detector output is automatically set to zero when this method is downloaded.
19. Select a Data Rate of 1 Hz.
20. Enter 254 nm for Wavelength.
21. Leave all other settings in this window in their default values for now.

Figure 36 Det 166-254 Initial Parameters tab.

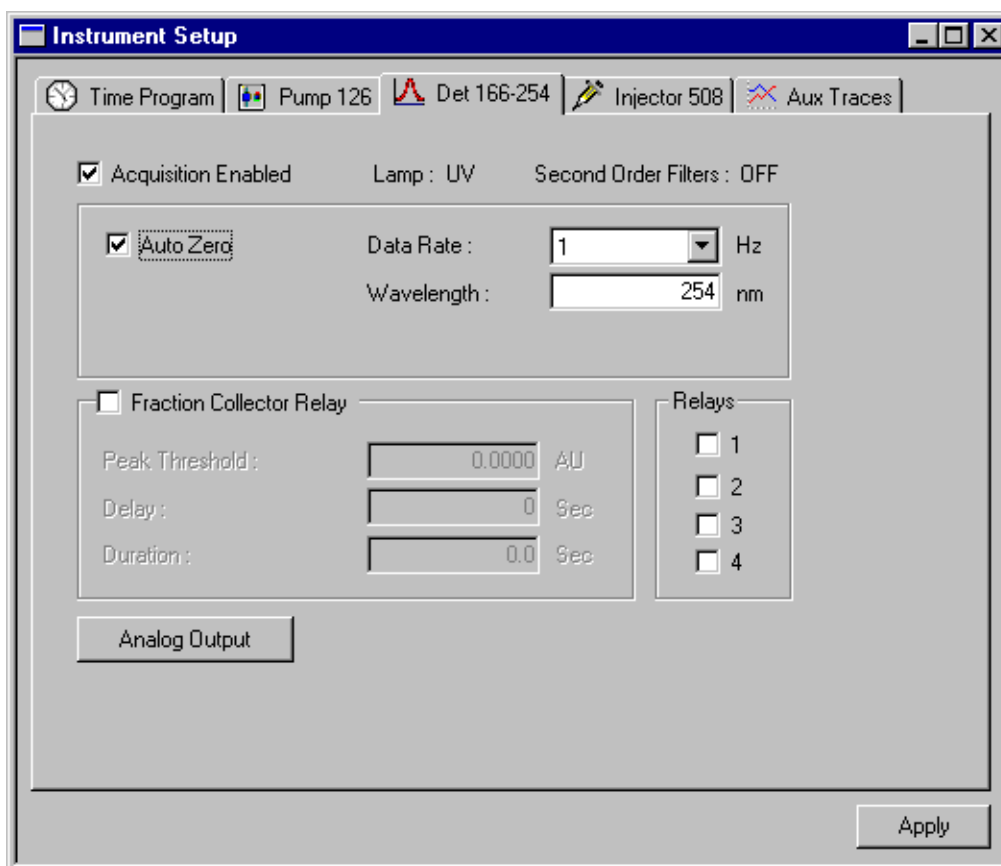

Time Program tab

22. Select the Time Program tab.

Figure 37 Time Program tab

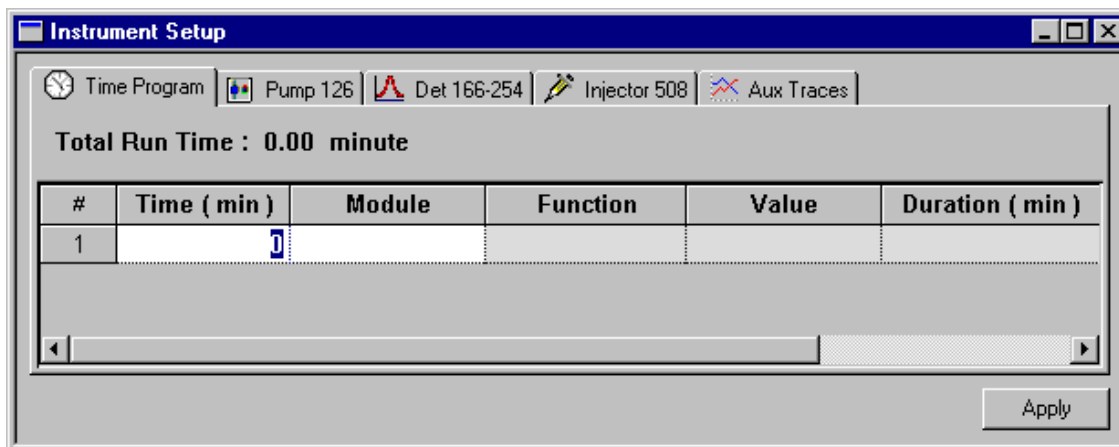

23. Enter 0.00 in the Time column.
24. Press the Tab key to move to the Module column.
25. Click on the down arrow located at the right of the Module column.
26. The contents of the drop-down menu in the Module column will reflect the Instrument configuration.

Figure 38 Time Program tab showing the Module drop-down menu

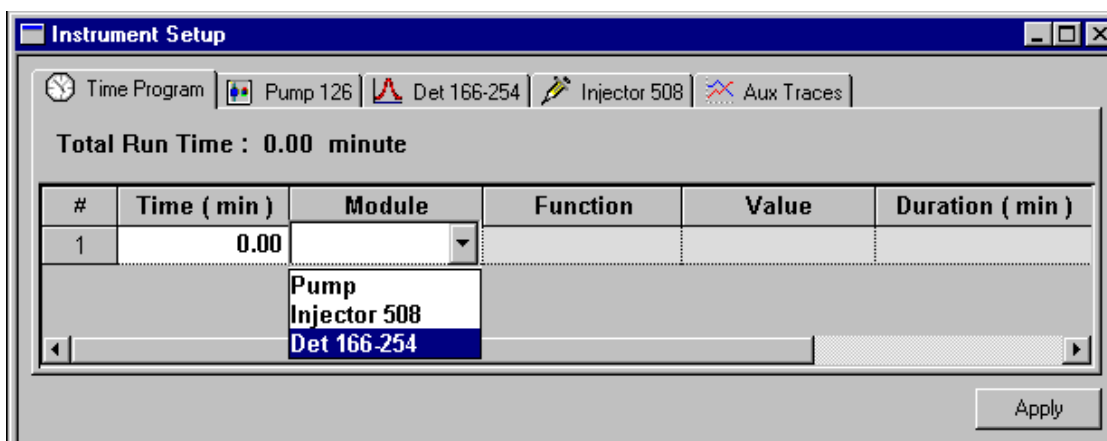

27. Select the 166 Detector (Det 166-254) option from the drop-down list.

28. Press the Tab key to move to the Function column.
29. Click on the down arrow located at the right of the Function column.
30. The drop-down menu in the Function column will reflect the selection made in the module column.
31. Select Autozero from the drop-down menu. This will automatically “autozero” the detector at the start of data collection.

Figure 39 Time Program tab showing the Function drop-down menu

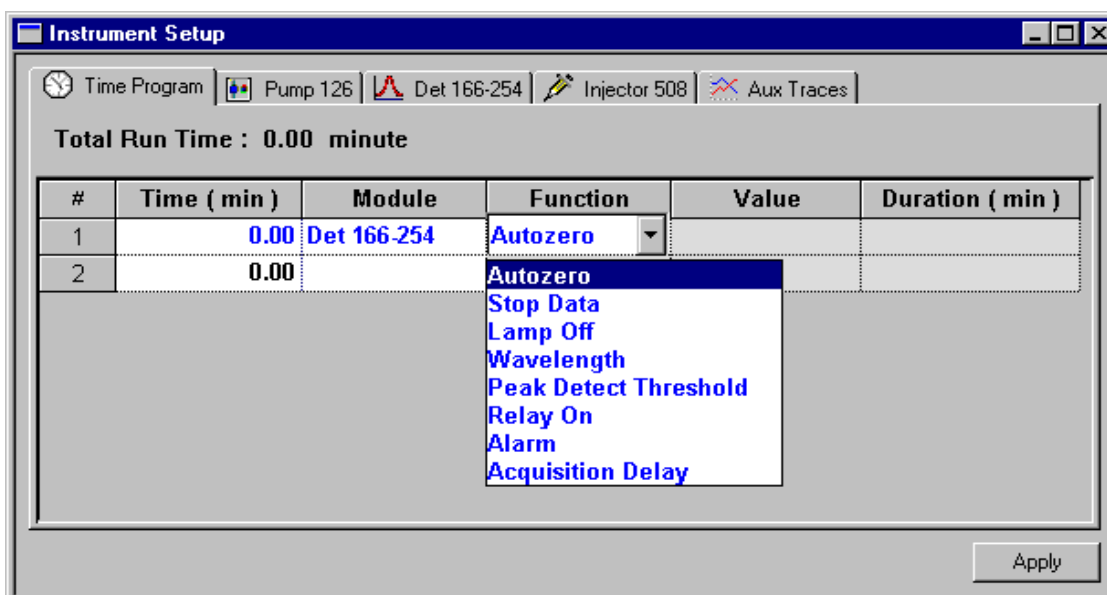

32. This function does not require an entry in the Value or Duration column
33. In line 2, enter 0.00 in the Time column.
34. Press Tab to move to the Module column.
35. Click on the down arrow located at the right of the Module column, and select Pump from the drop-down list.
36. Press Tab to move to the function column.
37. Click on the down arrow located at the right of the Function column and select %B from the drop-down menu.
38. This function requires an entry in both the Value and Duration column.
39. Enter 80.00 in the Value column and 2.00 in the Duration column.

40. This Time Program line will change the %B from 60 (the value entered in the %B field in the Pump Initial Parameters tab) to 80 (entered in the Value column) over 2 minutes (entered in the Duration column).

Figure 40 Time Program tab with the gradient method lines 1 and 2.

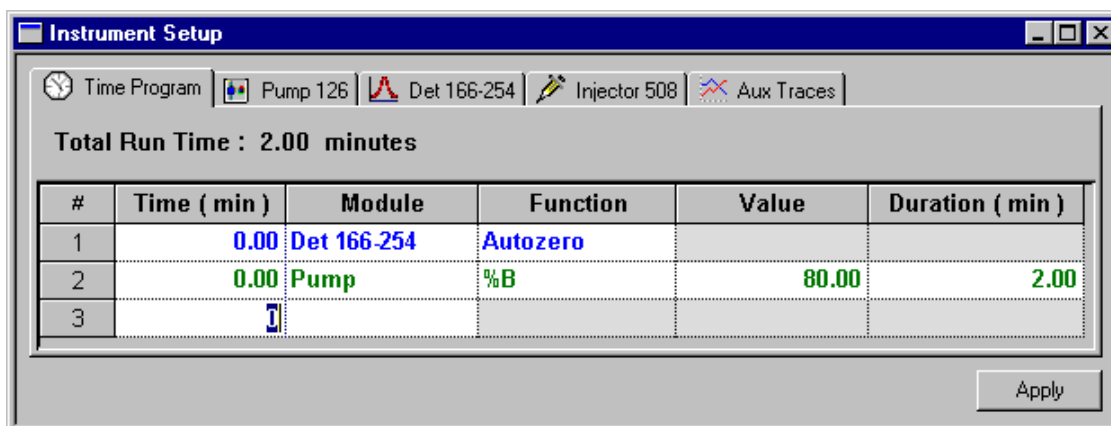

41. In the third line of the Time Program tab, enter 6.00 in the Time column.
42. Press Tab to move to the Module column.
43. Click on the down arrow located at the right of the Module column, and select Pump from the drop-down list.
44. Press Tab to move to the function column.
45. Click on the down arrow located at the right of the Function column and select %B from the drop-down menu.
46. This function requires an entry in both the Value and Duration column.
47. Enter 60.00 in the Value column and 1.00 in the Duration column.
48. This Time Program line will return the pump solvent composition to the starting conditions at the end of the method.
49. In the fourth line of the Time Program tab, enter 5.00 in the Time column.
50. Press Tab to move to the Module column.
51. Click on the down arrow located at the right of the Module column, and select the 166 Detector (Det 166-254) from the drop-down list.
52. Press Tab to move to the function column.
53. Click on the down arrow located at the right of the Function column and select Stop Data from the drop-down menu.

54. The method end time is automatically calculated by 32 Karat Software - based on the last timed event. *Data collection will end at 5.0 minutes and the method will end at 6.0 minutes.*
55. The Time Program window on your computer should look like the following:

Figure 41 Time Program tab with all of the Time Program lines entered as described above.

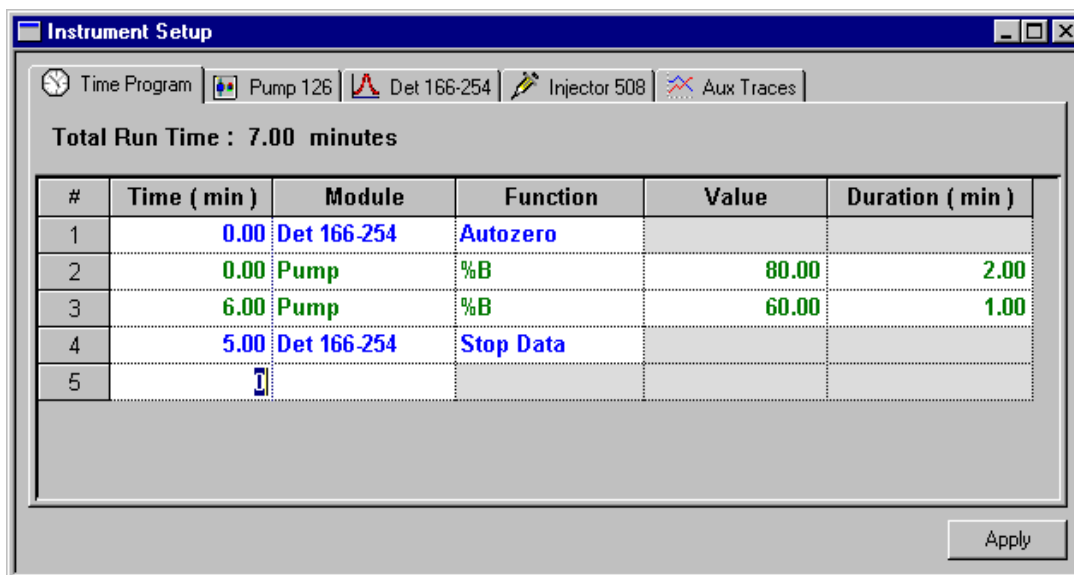

To finish creating your method, skip to the Injector Tab section of this manual to set the parameters for your Injector (see pages 5-10 and 5-11).

After completing the Injector Tab section, select File/Method/Save as... and save the method as "Tutorial Gradient" (see page 5-12).

Close the Instrument Setup window by clicking on the 'X' in the upper right-hand corner.

There are many more functions that 32 Karat Software can perform during a method. This is the minimum amount of information that 32 Karat Software needs to run a gradient method.

PDA Methods

This section will guide you through creating a method to run the Q.C. test mix with a PDA Detector. Use the previous gradient method section (page 5-16) to set up the pump portion of the method. The following section describes setting up the PDA detector only.

Notice

You must have a PDA detector connected to your instrument to complete this section. If you do not have a PDA detector, you may skip this section.

1. Return to the Enterprise screen and re-configure your “Tutorial Instrument” instrument to include the PDA detector (see section 3). Enter a descriptive name for the 168 Detector, such as “PDA-168”.
2. Once the configuration is complete, double click on the “Tutorial Instrument” icon. This opens the Instrument window. All method editing, data collection, data analysis and report generation is done within the Instrument Window.
3. To create a new method, select File/Method/New. Then from the Method menu, select Instrument Setup to display the Instrument Setup window.

Figure 42 Instrument setup window with tabs for Time Program, 126 Pump, 168 Detector, 508 Autosampler and Aux Traces.

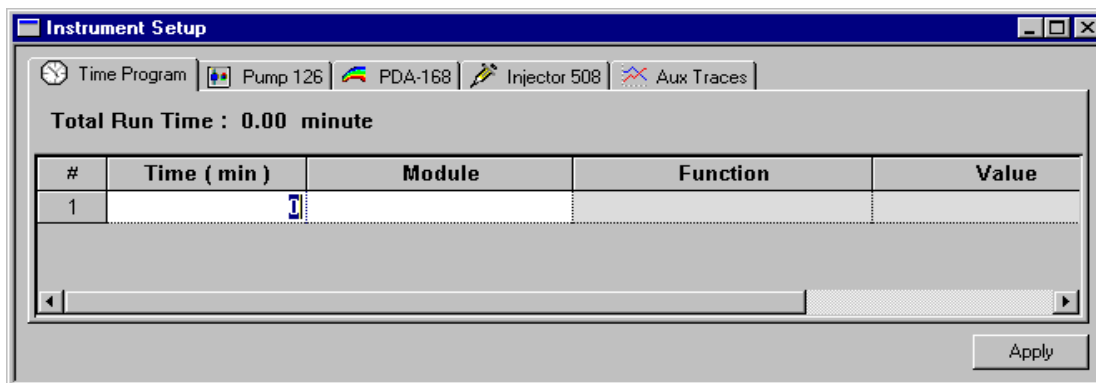

4. Select the PDA 168 Tab.
5. This tab is used to enter the parameters for diode array data collection.
6. The 168 Diode Array detector can collect both two dimensional data (channel definition) and three dimensional data (scan definition).
7. Make the following settings to match those shown in the figure below:
8. Select the “Acquisition Enabled” option.
9. Click the 3D data check box (inside the Scan Definition area) to enable 3D data collection.
10. Leave all other settings in this window in their default values for now (see figure below).

Figure 43 Diode Array Detector (model 168) tab - 3D data collection area.

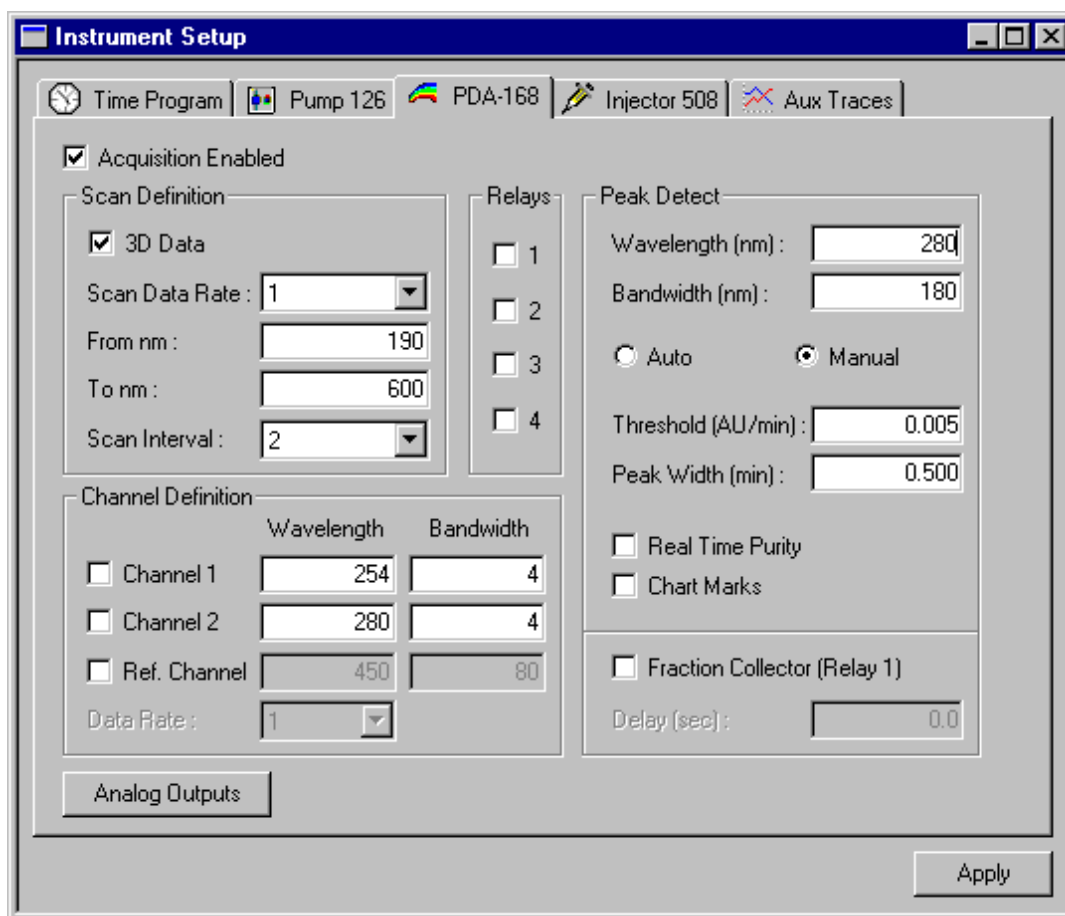

11. In the Channel Definition area click both the Channel 1 and Channel 2 check boxes.
12. This enables collection of the two data channels specified.
13. Set the Channel 1 Wavelength to 254 and the Bandwidth to 4.
14. Set the Channel 2 Wavelength to 280 and the Bandwidth to 4.
15. Leave all other settings in this window in their default values for now (see figure below).

Figure 44 Diode Array Detector (model 168) tab - Channel data collection area.

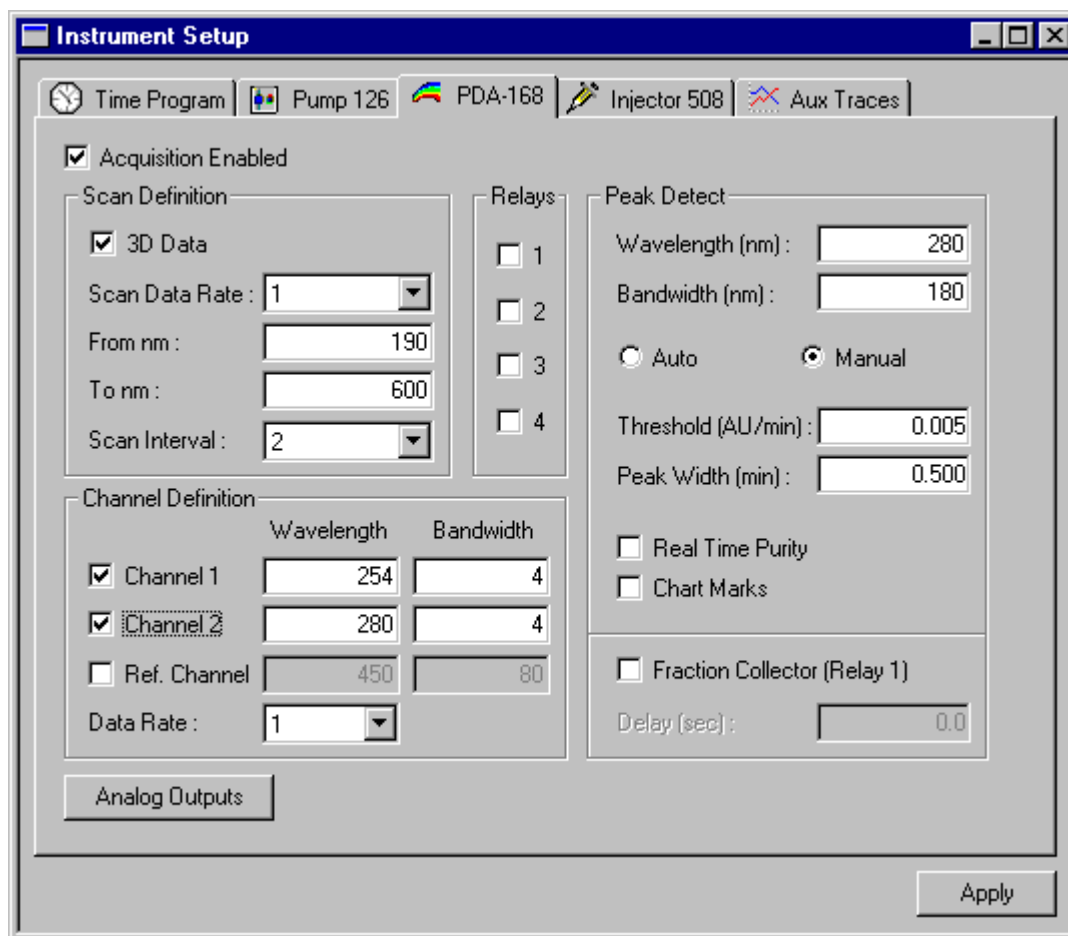

16. On the toolbar, open the Method menu and select the PDA Options command
17. Select the Multi-Chromatogram tab.
18. The channels specified here are associated with the 3D data and can be used to analyze and quantitate the data.
19. Click the Enabled check box.
20. Enter 254 in the Wavelength column and 4 in the Bandwidth column.
21. When one line has been entered, another will become available.
22. There is no minimum or maximum number of Multi-Chromatogram channels.
23. Refer to the Online Help for more information regarding Multi-Chromatograms.

Figure 45 PDA Options window / Multi-Chromatogram tab.

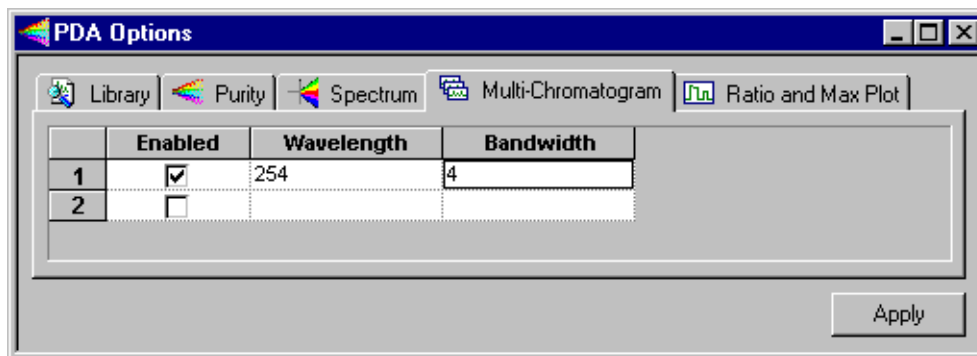

24. Return to the Instrument Setup window and select the Time Program Tab.
25. Enter 0.00 in the Time column.
26. Press Tab to move to the Module column.
27. Click on the down arrow located at the right of the Module column and select the 168 Detector "PDA-168" from the drop-down list.
28. Press Tab to move to the function column.
29. The drop-down menu choices in the Function column will reflect the component selected in the module column.
30. Select Autozero in the Function column.
31. This function does not require an entry in the Value or Duration column.

Figure 46 Time Program tab.

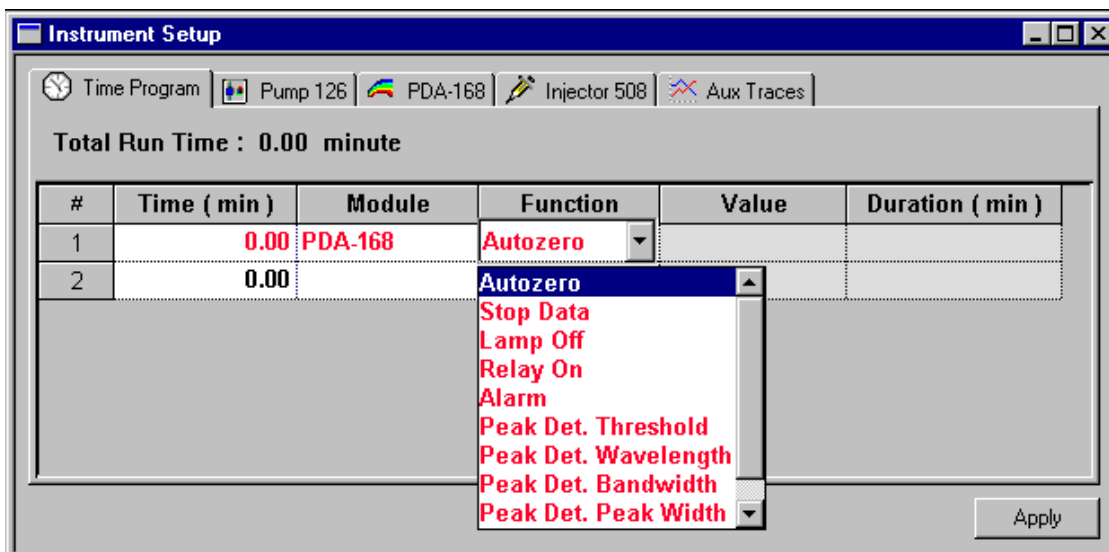

32. In line 2, enter 0.00 in the Time column.
33. Press Tab to move to the Module column.
34. Click on the down arrow located at the right of the Module column, and select Pump from the drop-down list.
35. Press Tab to move to the function column.
36. Click on the down arrow located at the right of the Function column and select %B from the drop-down menu.
37. This function requires an entry in both the Value and Duration column.
38. Enter 80.00 in the Value column and 2.00 in the Duration column.

39. This Time Program line will change the %B from 60 (the value entered in the %B field in the Pump Initial Parameters tab for the gradient method - page 5-16) to 80 (entered in the Value column shown below) over 2 minutes (entered in the Duration column shown below).

Figure 47 Time Program tab with the PDA gradient method lines 1 and 2.

#	Time (min)	Module	Function	Value	Duration (min)
1	0.00	PDA-168	Autozero		
2	0.00	Pump	%B	80.00	2.00
3	0.00				

40. In the third line of the Time Program tab, enter 6.00 in the Time column.
41. Press Tab to move to the Module column.
42. Click on the down arrow located at the right of the Module column, and select Pump from the drop-down list.
43. Press Tab to move to the function column.
44. Click on the down arrow located at the right of the Function column and select %B from the drop-down menu.
45. This function requires an entry in both the Value and Duration column.
46. Enter 60.00 in the Value column and 1.00 in the Duration column.
47. Line 3 will return the pump solvent composition to the starting conditions for the next method, or initial parameters.
48. In the fourth line of the Time Program tab, enter 5.00 in the Time column.
49. Press Tab to move to the Module column.

50. Click on the down arrow located at the right of the Module column, and select the 168 Detector "PDA-168" from the drop-down list.
51. Press Tab to move to the Function column.
52. Click on the down arrow located at the right of the Function column and select Stop Data from the drop-down menu.
53. The method end time is automatically calculated by 32 Karat Software - based on the last timed event. *Data collection will end at 5.0 minutes and the method will end at 6.0 minutes.*
54. The Time Program window on your computer should look like the following:

Figure 48 Time Program tab with all of the Time Program lines entered as described above.

#	Time (min)	Module	Function	Value	Duration (min)
1	0.00	PDA-168	Autozero		
2	0.00	Pump	%B	80.00	2.00
3	6.00	Pump	%B	60.00	1.00
4	5.00	PDA-168	Stop Data		
5					

To finish creating your method, skip to the Injector Tab section of this manual to set the parameters for your Injector (see pages 5-10 and 5-11).

After completing the Injector Tab section, select File/Method/Save as... and save the method as "Tutorial PDA" (see page 5-12).

Close the Instrument Setup window by clicking on the 'X' in the upper right-hand corner.

There are many more functions that 32 Karat Software can perform during a method. This is the minimum amount of information that 32 Karat Software needs to run a PDA method.

Editing a Method

You can create and edit a method in the Instrument window. From the 32 Karat Software Enterprise Screen, double click on the “Tutorial Instrument” icon to open the Instrument window.

1. From the Instrument window, open the File menu and select Method/Open.

Figure 49 Method/Open menu items.

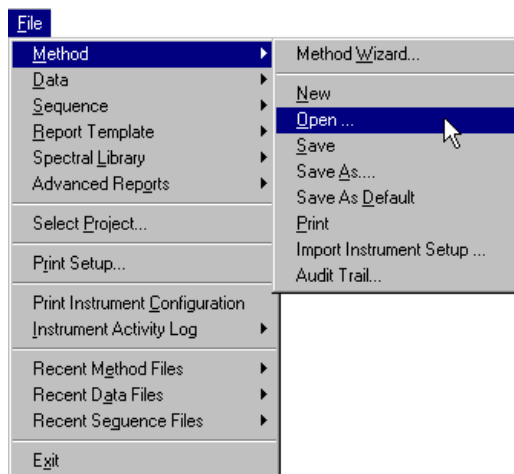

2. From the Open Method File dialog box, select the Tutorial Gradient.met.

Figure 50 Open Method dialog.

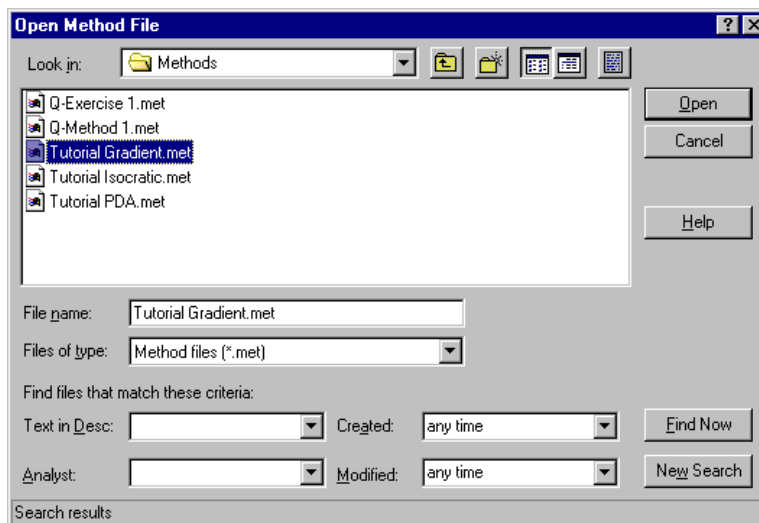

3. From the Method menu, select Instrument Setup. You can also access the Instrument Setup window by simply clicking the Instrument Setup icon located on the toolbar or by pressing the *Ctrl + Shift + F2* keys.
4. Select the Initial Parameters tab for the Pumps.
5. Enter 1 for the Flow Rate, 5.00 for the Pressure Upper Limit, and 0.1 for the Pressure Lower Limit.
6. This lower pressure limit may be raised during a run to stop the pumps in case of a leak.

Figure 51 Pump tab.

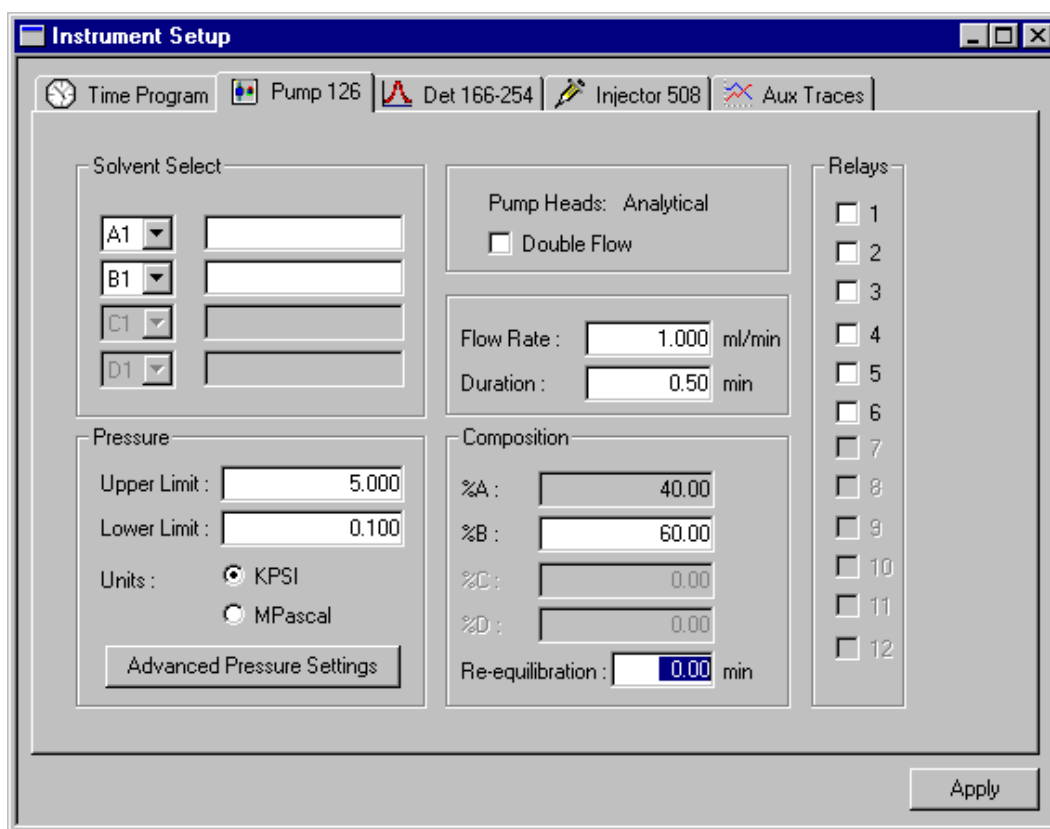

Notice

To begin pumping, the lower limit must always be set to zero. This value can then be changed after the pump's pressure has increased.

7. Select the Time Program tab.
8. In the fifth line of the Time Program window, enter 3.8 in the Time column.
9. Press tab to move to the Module column. Click the down arrow located at the right of the Module column and select the 166 Detector from the drop-down list.
10. Press tab to move to the Function column. Click the down arrow located at the right of the Function column and select the “Alarm” from the drop-down list
11. This function requires an entry in only the Duration column. Enter 1.0 as the value.
12. The Time Program dialog on your computer should look like the following:

Figure 52 Edited time programming spreadsheet.

#	Time (min)	Module	Function	Value	Duration (min)
1	0.00	Det 166-254	Autozero		
2	0.00	Pump	%B	80.00	2.00
3	6.00	Pump	%B	60.00	1.00
4	5.00	Det 166-254	Stop Data		
5	3.80	Det 166-254	Alarm		1.00
6					

To save your edited method, open the File menu and select Method / Save... or simply click on the Save button located on the toolbar.

The method “Tutorial Gradient.met” is saved with the edited changes.

Double-click on the ‘X’ in the upper left-hand corner of the Instrument Setup window.

You have completed the Creating and Editing a Method section of the User's Guide.

Section 6 - Running the System

Introduction

In the last section you created an instrument method. In this exercise you will run that method in Single Run mode. In this mode, the method will download and start when the single run is started. This section will show how to inject a sample and acquire data. The stored data file will be used later in this book to optimize the method integration and prepare calibration tables.

Single mode is useful in method development, where the results of one run will suggest modifications to the method or other procedures. In the second part of this section you will create a Sequence to do multiple runs.

You must be “online” to run samples and acquire data. If you are not online, “(offline)” will appear in the title bar of the instrument window. Close any offline windows before proceeding. From the main 32 Karat Software screen, double click on an instrument icon to go “online”.



NOTE

The detector lamp must be ON prior to starting a method. The status of the lamp is available in the Direct Control window and may be turned ON from there.

Setting up a Single Run

From the 32 Karat Software Enterprise Screen, double click the “Tutorial Instrument” icon to open the Instrument window.

1. To start the run, click on the Single Run button, or select Control/Single Run. The following dialog box appears:

Figure 53 Single run dialog with Manual Injector configured

Single Run Acquisition

Run information

Sample ID: Single Run Tutorial

Method: D:\32Karat\Projects\Default\Methods\Tutorial Is

Data path: D:\32Karat\Projects\Default\Data

Data file: Tutorial Data 1

Print method report

Amount values

Sample amount: 1

Internal standard amount: 1

Multiplication factor: 1

Calibrate

Calibration level: 1

Clear all calibration

Clear calibration for level

Print calibration report

Clear replicates

Average replicates

Start

Cancel

Help

Description...

2. In the Sample ID field enter “Single Run Tutorial”.
3. Click on the browse button (file folder) for the Method field and select “Tutorial Isocratic.met” from the list of methods.
4. Type “Tutorial Data 1” in the Data File box. This is the file name that will be used to save the chromatogram on disk.
5. To start acquisition, click Start.

- If using manual injection, load the sample and wait for the “waiting for trigger” message to appear on the Status bar. When the valve is rotated from the “load” to the “inject” position, data acquisition begins.
- If using an autosampler, enter the vial number and injection volume (see figure 54 below). When the autosampler injects, data acquisition begins.

Figure 54 Single run dialog with Autosampler configured

The screenshot shows the 'Single Run Acquisition' dialog box. It is divided into several sections:

- Run information:** Sample ID: Single Run Tutorial; Method: D:\32Karat\Projects\Default\Methods\Tutorial Is; Data path: D:\32Karat\Projects\Default\Data; Data file: Tutorial Data 1. There is a checkbox for 'Print method report' which is unchecked.
- Amount values:** Sample amount: 1; Internal standard amount: 1; Multiplication factor: 1.
- Calibrate:** A checkbox for 'Calibrate' is unchecked. Below it are several options: Calibration level: 1; Clear all calibration; Clear calibration for level; Print calibration report; Clear replicates; Average replicates.
- Autosampler:** Vial: 1; Injection volume: 10.

Buttons on the right side include Start, Cancel, Help, and Description...

The remaining items on this screen are not required to run a method. For information on those features, see the resources in Appendix 1.

This method will be used for additional exercises. Please do not continue to the next section until you have achieved a successful single run.

This completes the Single Run section of the User’s Guide.

Setting up a Sequence Run

This exercise will show how to create a Sequence Table in order to automate data acquisition. A Sequence Table is a work list that specifies what samples are to be run, the order in which they are to be run, and any special instructions (such as calibration). Sequences can also be used for reprocessing data after it has been saved on disk. The objectives of this exercise are to:

- Create a Sequence.
- Run the Sequence.

Creating a Sequence

32 Karat Software includes a Sequence Wizard to simplify the sequence generation process:

1. From the menu bar, select File / Sequence / Sequence Wizard.

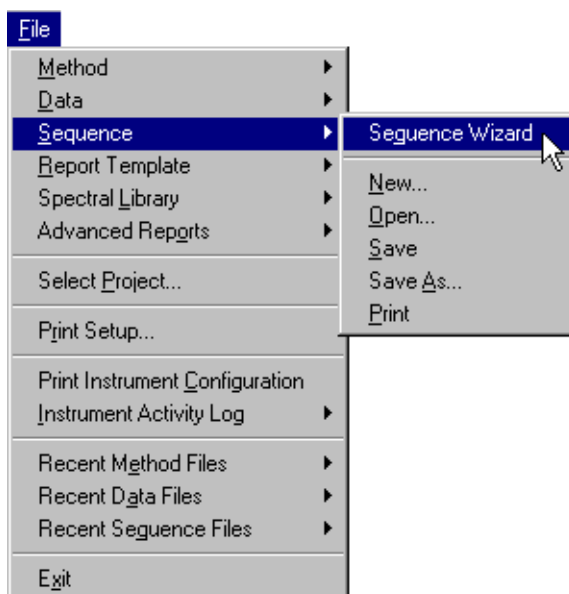

2. This will start the Sequence Wizard.

3. In the Sequence Wizard - Method dialog click on the browse button next to the Method field.

Figure 55 Sequence Wizard - Method selection

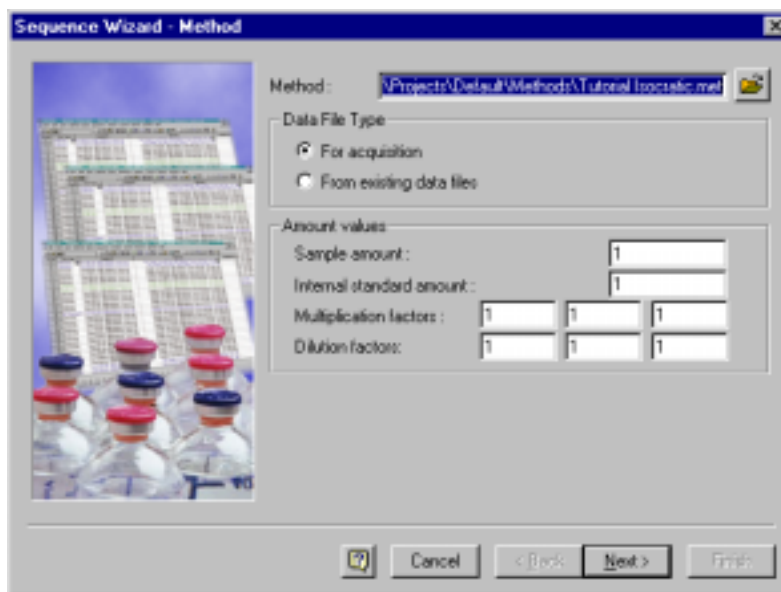

4. Select “Tutorial Isocratic.met” from the Open Method File dialog.

Figure 56 Open Method File dialog with Tutorial Isocratic.met selected.

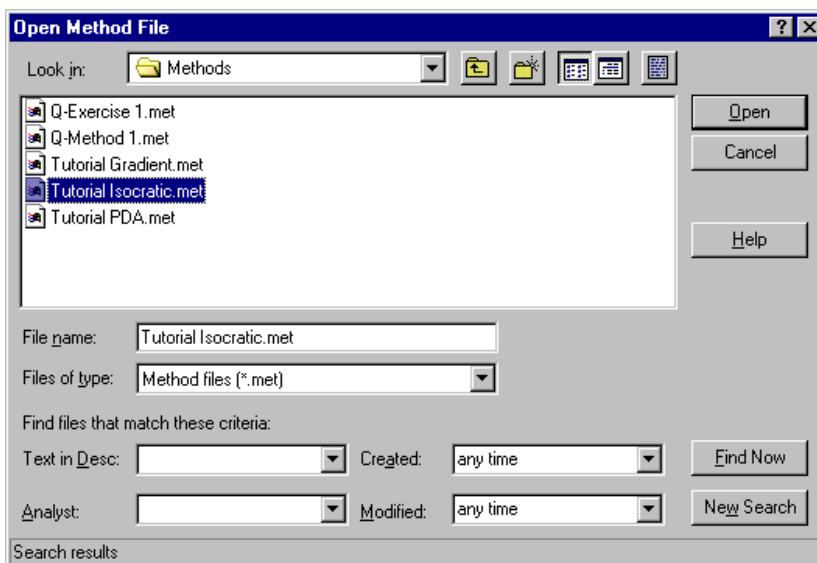

Notice

The Sequence Wizard - Method dialog contains three input fields next to each of the Multiplication factors and Dilution factors parameters (see figure 55). The values entered into each of these three fields are multiplied together to give the total multiplication factor or dilution factor made to the sample. Alternatively, you can simply input the total multiplication or dilution value (if any were made to your sample) into one of the three fields and leave the values for the two remaining fields equal to "1". For more information, refer to the Online Help.

5. After you have made your selections in the Sequence Wizard - Method dialog, click Next to proceed to the Sequence Wizard - Unknowns dialog.
6. In the Sequence Wizard - Unknowns dialog enter "Tutorial Sequence" in the Sample ID field. Enter "Sequence Data" in the Data File field.
7. Click the blue arrow at the end of the Data File field and select Increment Number.
8. Enter "3" in the Number of unknown runs in sequence field.

Figure 57 Sequence Wizard - Unknowns dialog with the above information entered.

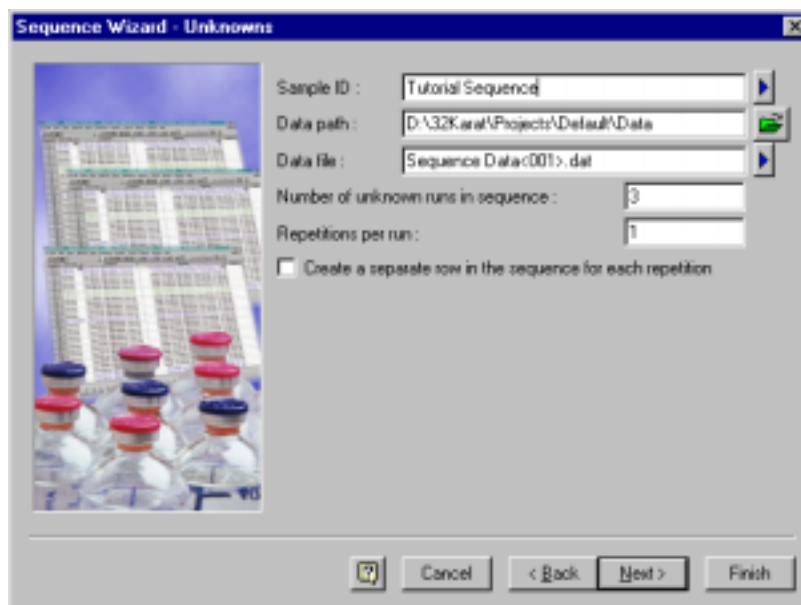

9. Click Next to proceed to the Sequence Wizard - Autosampler dialog.
10. In the Sequence Wizard - Autosampler dialog enter “1” in the First unknown vial of sequence field. Enter “10” in the Autosampler injection volume field.

Figure 58 Sequence Wizard - Autosampler dialog with the above information entered.

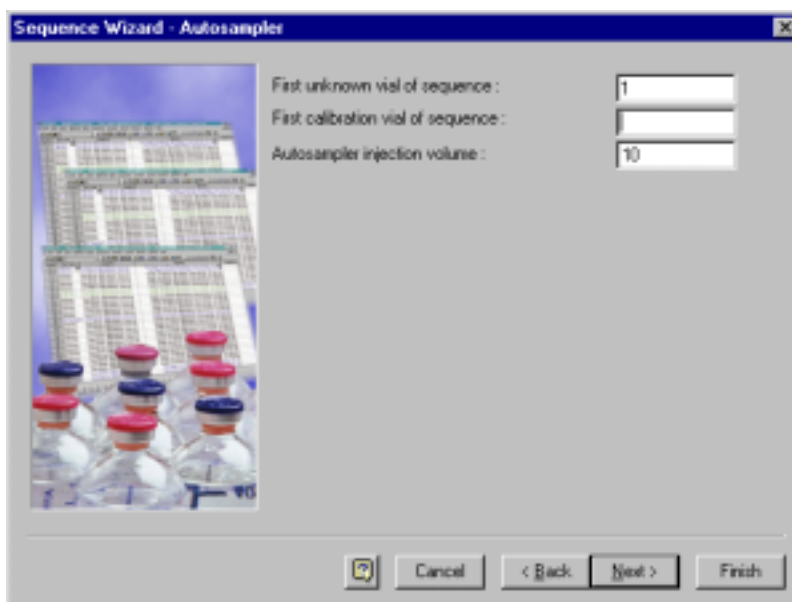

11. Click Finish.
12. The remaining Sequence Wizard dialogs will be discussed in other exercises.
13. The Sequence should look like the one below:

Figure 59 New sequence

Run #	Status	Run Type	Level	Conc Override	Reps	Vial	Volume	Sample ID	Method	Filename
1		Unknown	0	n/a	1	1	10	Tutorial Sequence	Tutorial Isocratic.met	Sequence Data001.dat
2		Unknown	0	n/a	1	2	10	Tutorial Sequence	Tutorial Isocratic.met	Sequence Data002.dat
3		Unknown	0	n/a	1	3	10	Tutorial Sequence	Tutorial Isocratic.met	Sequence Data003.dat
4										

14. To Save the Sequence click on the Save button on the Tool bar and select Sequence.
15. Enter "Tutorial Sequence" in the File name dialog and click Save.

Figure 60 Save As dialog with the above information entered.

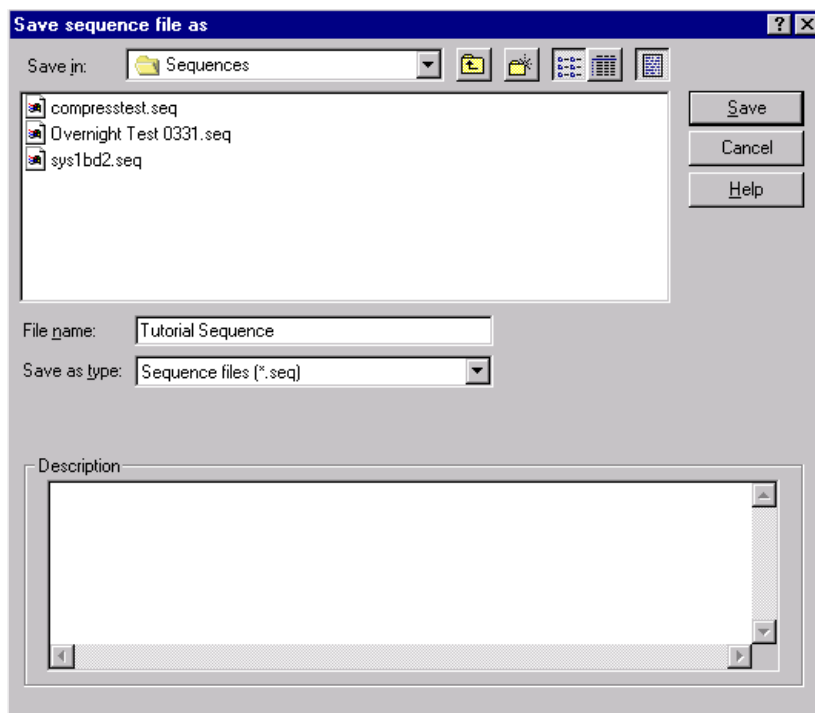

Running the Sequence

Now, run the sequence from the instrument window. If using manual injection during batch acquisition, it is crucial to inject standards and samples in the exact order they are specified in the sequence.

1. Click on the Sequence Run button (Control/Sequence Acquisition). The following dialog box appears:

Figure 61 Run Sequence dialog.

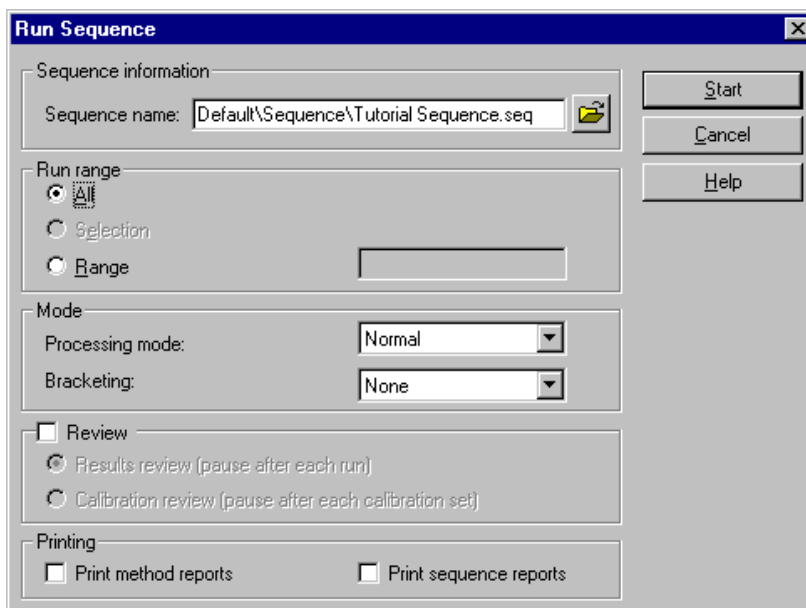

2. Enter the sequence name and designate All as the Run Range
3. When ready to start the sequence acquisition, click on Start.

The remaining items on these screens are not required to run the sequence. For information on those features, see the resources in Appendix 1.

This completes the Sequence Run section of the User's Guide.

Section 7 - Optimizing the Method

Once a data file has been collected it can be used to further optimize the method.

Before beginning the method optimization, open the method and data file created in the previous exercises.

1. Click on the Open button on the tool bar.
2. Select Open Data.
3. In the Open Data File dialog box select Tutorial Data 1. **ALSO**, in the Options focus area, click the Method pull-down menu and select Original/Acquisition. This will open the method with which this data file was collected.

Figure 62 Open Data File dialog with “Tutorial Data 1” file selected and the option to open the data file with the Original / Acquisition method selected.

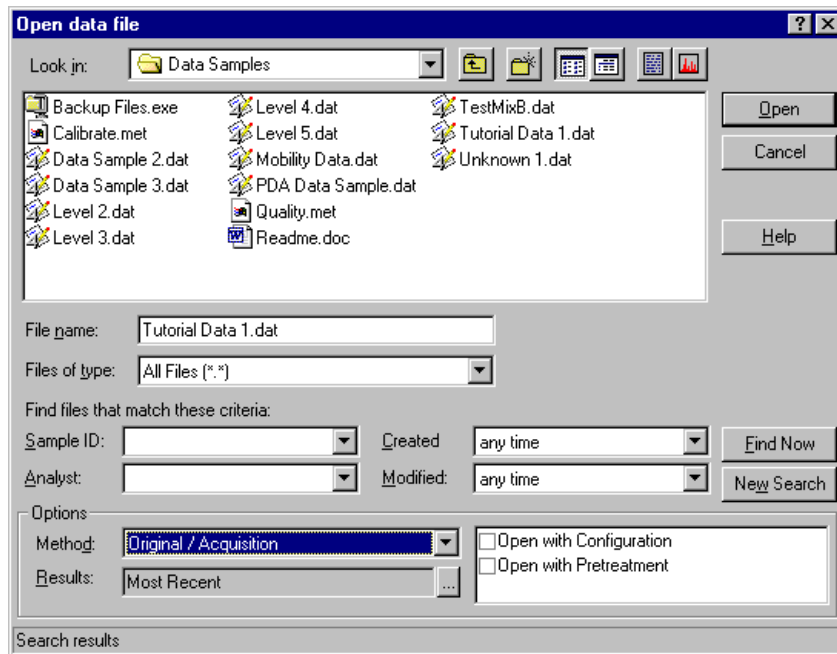

4. Click on the Open button.

Optimize Integration Events

Now that the standard sample has been acquired, use the stored chromatogram to adjust the peak detection and integration parameters.

Two parameters are necessary for 32 Karat Software to integrate a chromatogram: Width and Threshold.

For details on how these values are used, refer to the Online Help screens.

1. Integrate the chromatogram using the current method parameters by clicking the Analyze button located on the toolbar.



2. The resulting baselines reflect how the chromatogram was integrated using the default parameters in the current method. Now, optimize the integration for the specific chromatography using the graphical events functions.

Figure 63 Analyzed chromatogram using only the default Width and Threshold parameters.

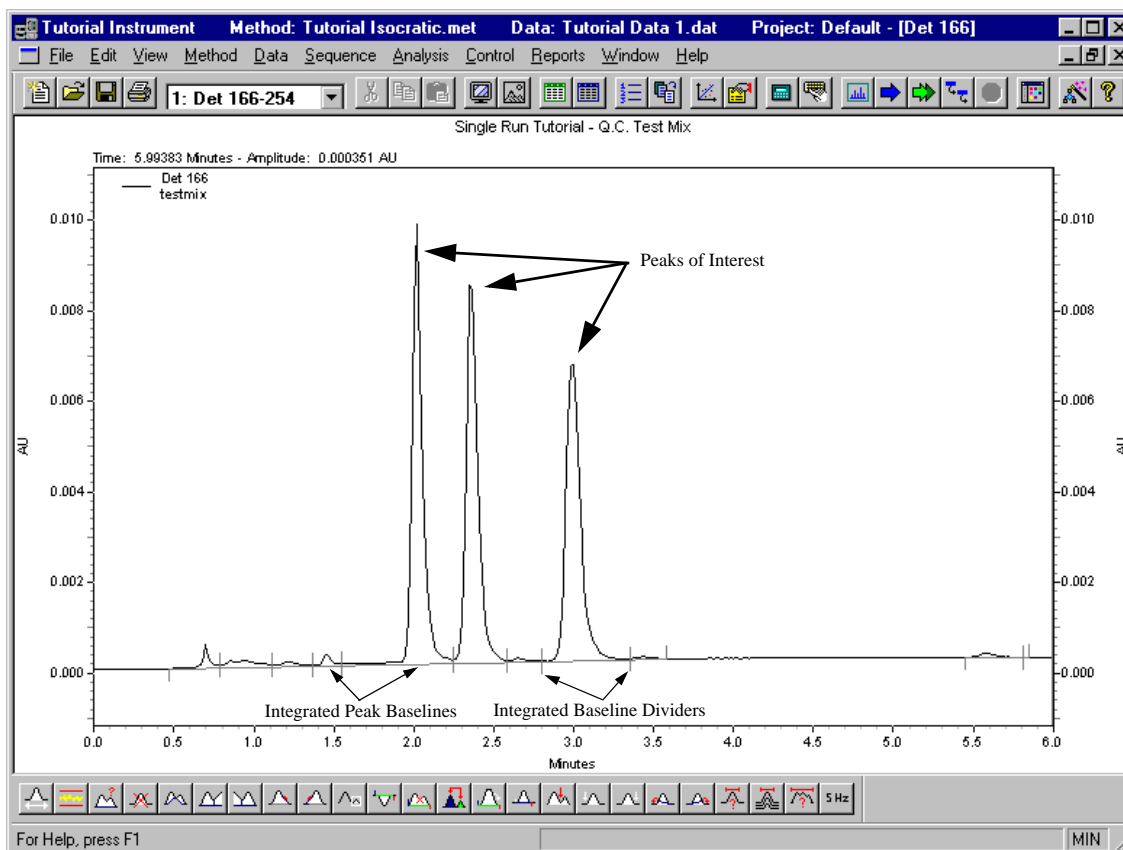

- At the bottom of the Instrument window is a Graphical Integration Toolbar that can be used to graphically enter Integration parameters into the method.

Figure 64 The Instrument window's Graphical Integration toolbar.

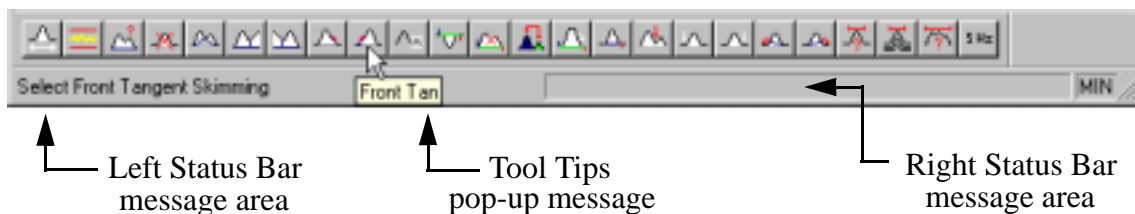

- First, you will set the new Threshold values for your data sample.
- Click on the Threshold button located on the Graphical Integration toolbar.

Notice

The tools can be identified by the caption in the Left Status bar (at the bottom left of the Instrument window) or the Tool Tips pop-up message. To see either of these, hold the cursor over the button.

Figure 65 Threshold button.



- As you move the cursor over the chromatogram, the arrow will turn into a “+” sign accompanied by a moving vertical bar which is used to set the location of the graphical integration function selected. When no integration function is selected, this cursor can also be used to select and zoom in on any area of the chromatogram.

7. The prompt "Select start of baseline segment" will appear in the Right Status bar.
8. Locate a section of the chromatogram where no peaks elute. Ideally, this should be near the beginning of the chromatogram just before the solvent front has eluted from the column.
9. Click the mouse at the beginning of the baseline section.

Figure 66 Setting the Threshold - Select start of baseline segment.

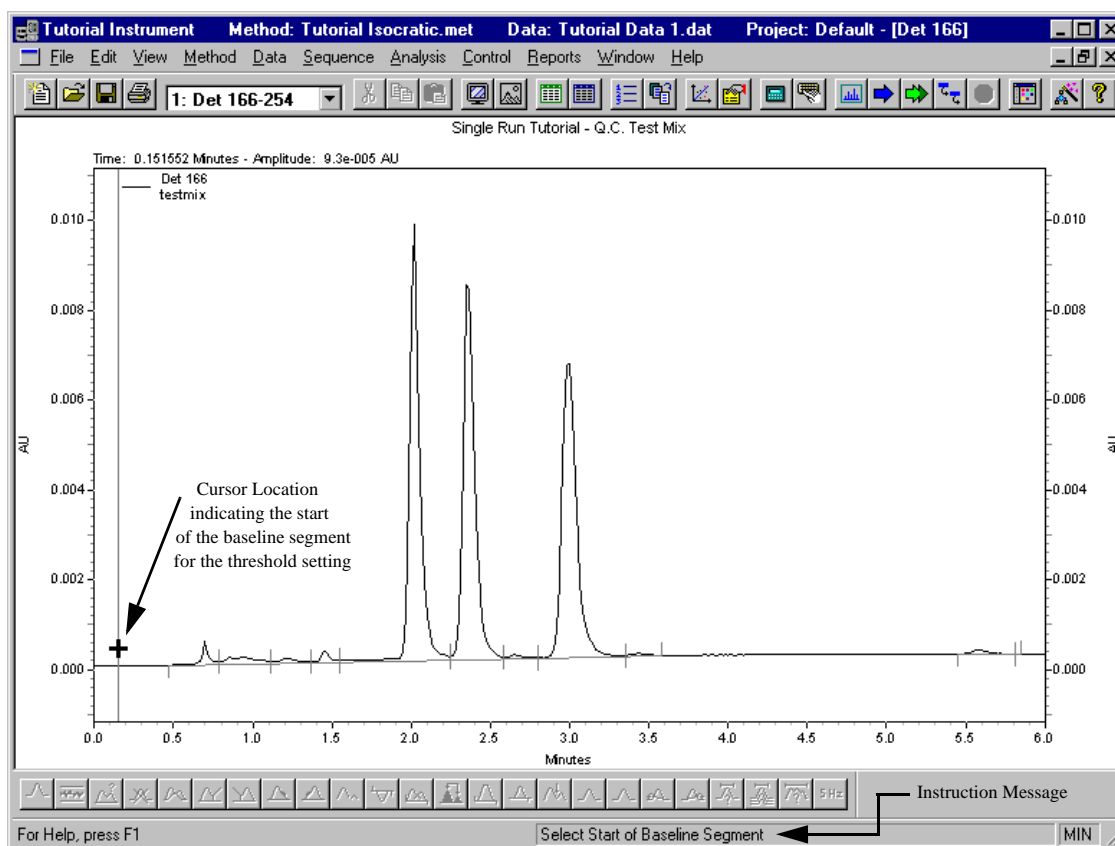

10. After you have clicked on the location of the start of the baseline segment, the Right Status bar will display the message “Select end of baseline segment”.
11. Click the mouse at the end of the baseline section. Ideally, this should be located just before the first peak you wish to integrate.

Figure 67 Setting the Threshold - Select end of baseline segment.

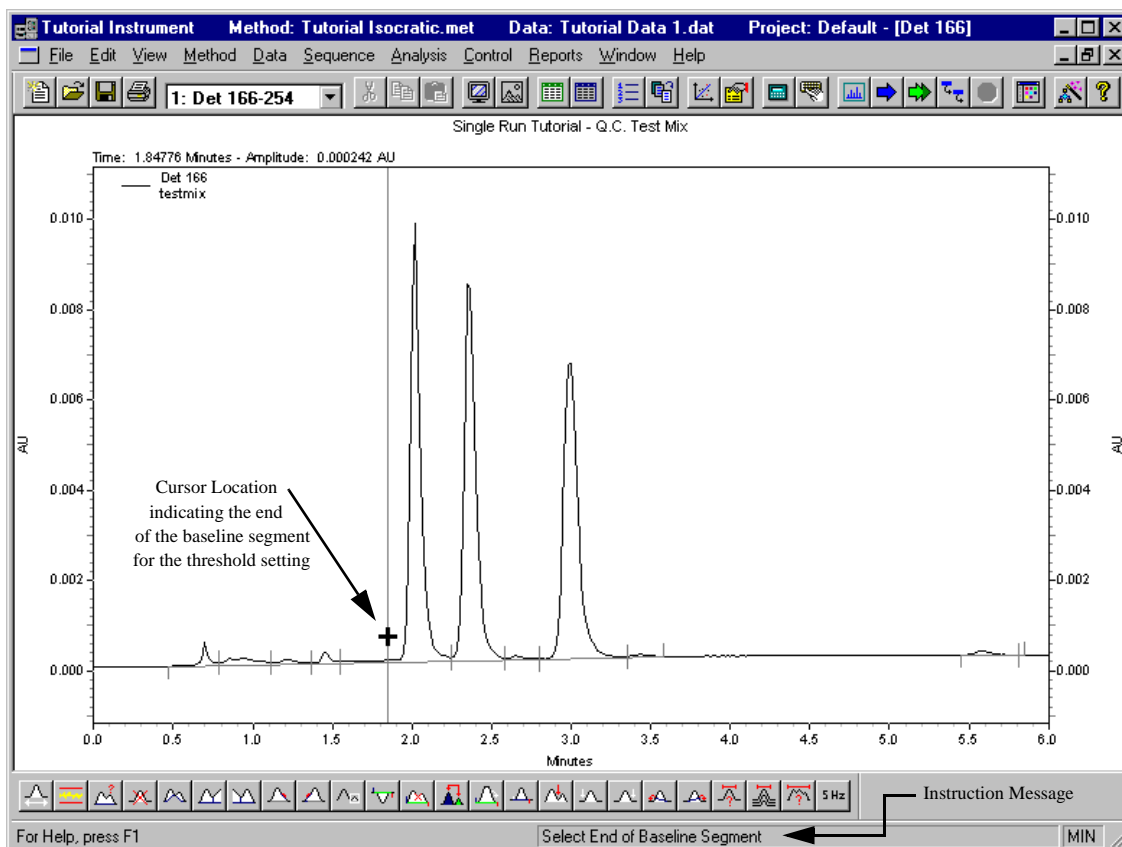

12. After you have clicked on the location of the end of the baseline segment, 32 Karat Software calculates a Threshold value based on the section of the selected chromatogram and displays the following dialog box:

Figure 68 Threshold dialog

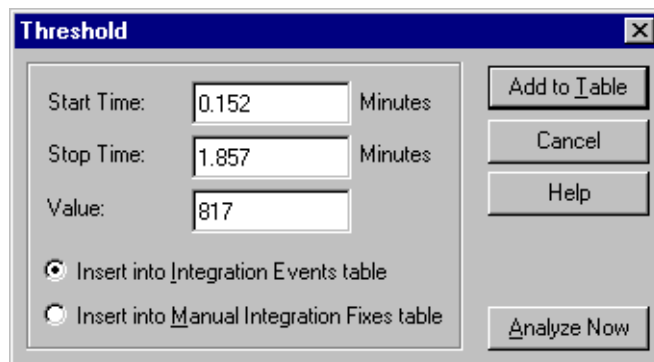

13. Click on the Analyze Now button to enter the value in the integration events table of the method, and to reintegrate the chromatogram using the new value.

- There should now be fewer areas of the chromatogram integrated.

Figure 69 Newly integrated chromatogram.

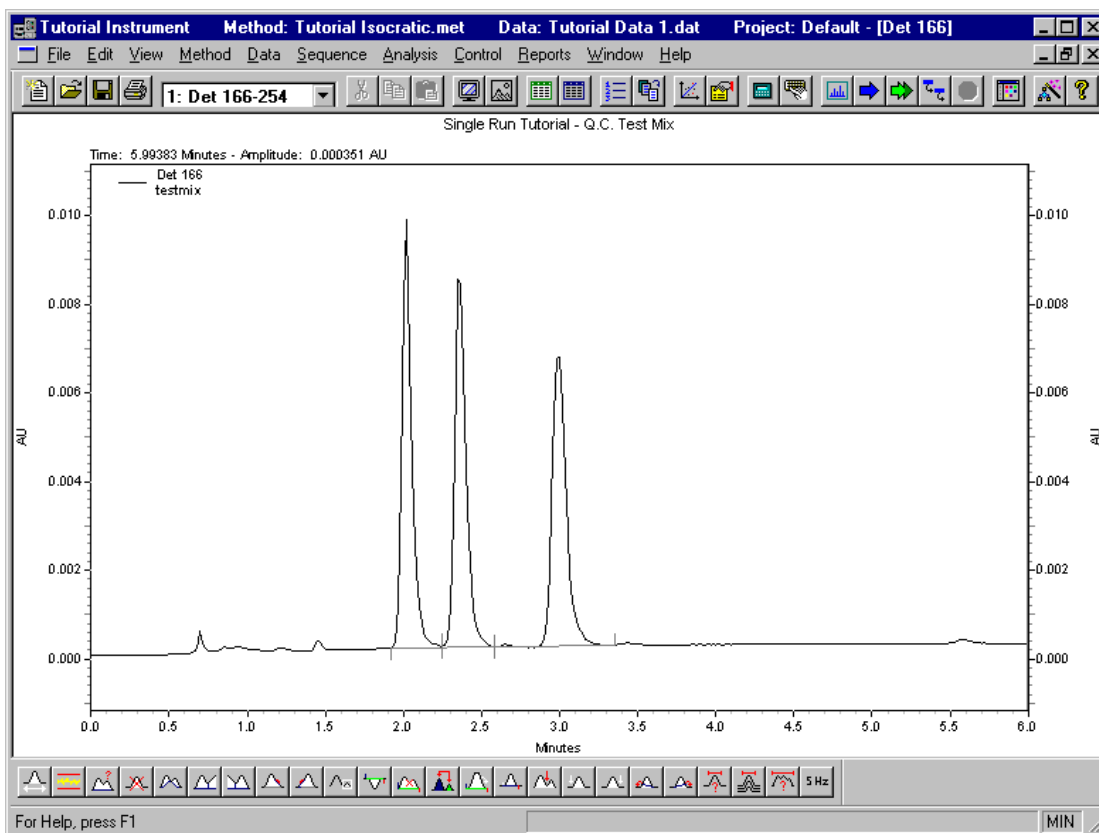

The threshold parameter is the first derivative, used to allow the integration algorithm to distinguish the start and stop of peaks from baseline noise and drift. It is also one way of eliminating integration of peaks not of interest. 32 Karat software uses a default value of 50 for the threshold. Integration of the Tutorial Data 1 file using this default value resulted in the integrated chromatogram shown in figure 63.

As you can see from the newly integrated chromatogram above, the new threshold values have removed the previously integrated peaks between 0 ~ 1.8 minutes and between 3.5 ~ 6 minutes from the integration table. This limits the integration to the three peaks in which we are interested.

Any number of threshold parameters can be set within a chromatogram. The first is usually set near the beginning of the chromatogram to eliminate integration of the solvent front and other components exiting the column unretained. Additional threshold parameters can be placed in other sections of the chromatogram, if necessary. For more information, refer to the Online Help.

15. Next, you will set the new Width values for your data sample.
16. Click on the Width button located on the Graphical Integration toolbar.

Figure 70 Width button.



17. The prompt “Select Peak Starting Point” will appear in the Right Status bar.
18. Locate the narrowest peak’s width to be set in the integration.
19. Click the mouse at the start of the peak.

Figure 71 Setting the Width - Select Peak Starting Point

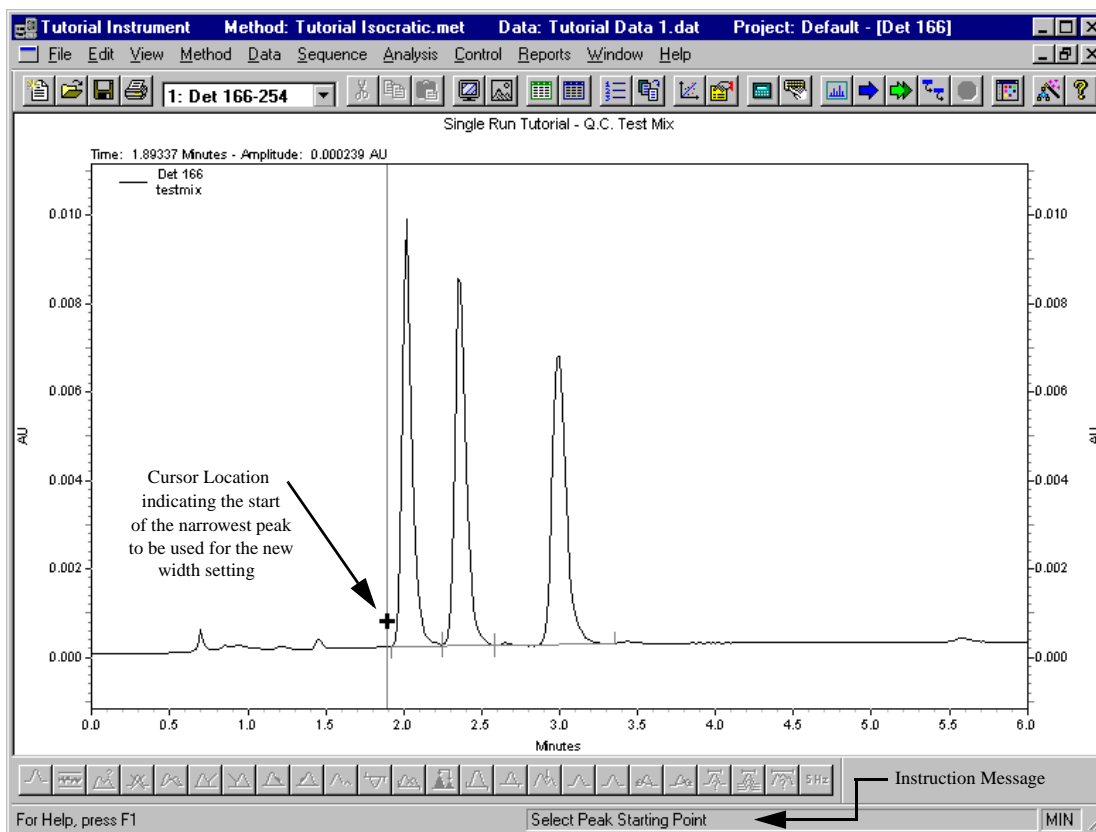

20. After you have clicked on the location of the start of the narrowest peak, the Right Status bar will display the message “Select Peak End Point”.
21. Click the mouse on the end of the peak.

Figure 72 Setting the Width - Select Peak End Point

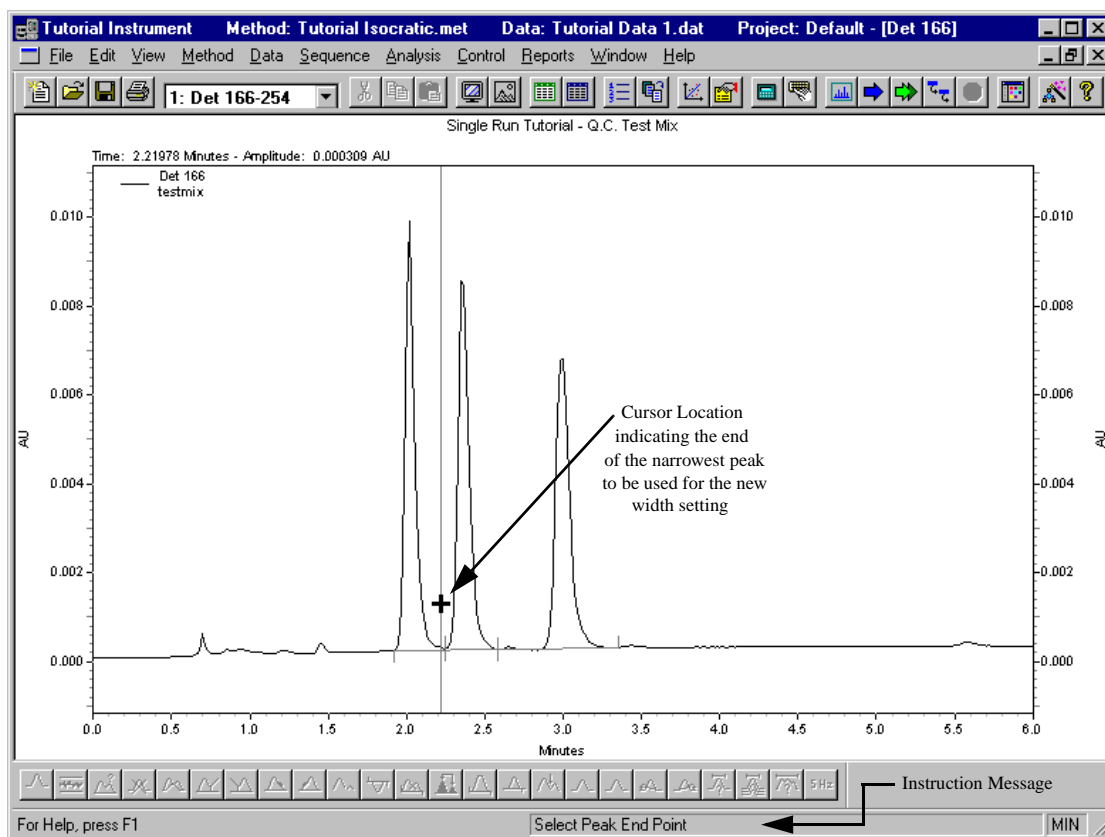

22. After you have clicked on the end of the peak, 32 Karat Software calculates the width value, based on the selected peak and displays the following dialog box:

Figure 73 Width dialog.

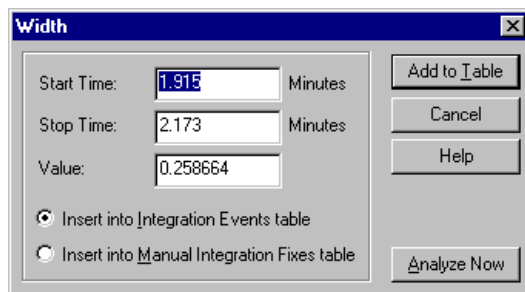

23. Click Analyze Now to enter the value in your integration events table of the method and reintegrate the chromatogram using the new value.

Figure 74 Newly integrated chromatogram

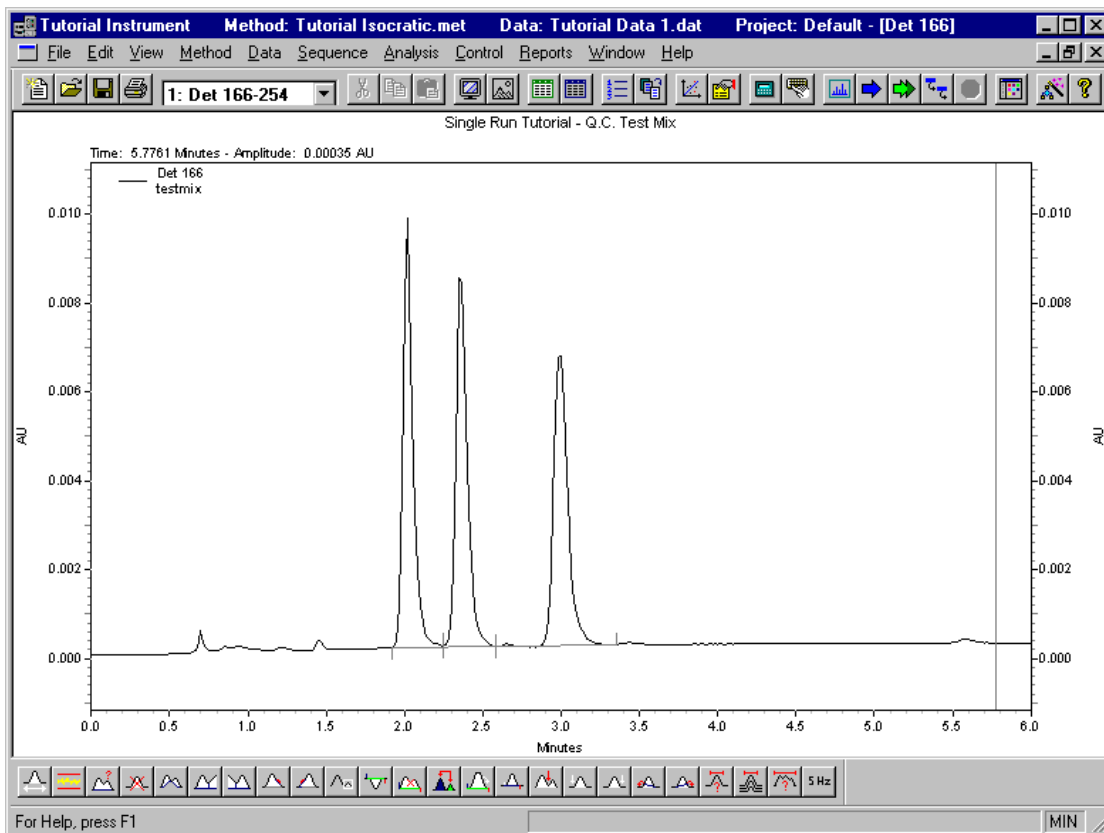

The Width event is used to calculate a value for bunching, or smoothing, the data points before the integration algorithm is applied. Integration works best when there are 20 points across a peak. If a peak is over sampled (i.e. the sampling frequency was too high), the Width parameter will be used to average the data such that the integration algorithm sees only 20 points across the peak. The Width parameter is only used to correct for over-sampling. It cannot correct for data that was under-sampled (i.e. sampling frequency too low causing fewer than 20 points acquired across the narrowest peak.)

In most circumstances, an initial Width value based on the narrowest peak in the chromatogram will be adequate for proper integration of all peaks. However, a new Width timed event should be entered every time a peak width doubles.

The system uses a default value of 0.2 minutes for the Width parameter.

24. You can view the Integration Events by opening the Method menu and selecting the Integration Events command. The Integration Events Table will be displayed.
25. To turn off a specific integration event, click on the red check mark to the left of the row to deselect it.
26. To delete a specific integration event, highlight the row by clicking on the row number and press the Delete key.

Figure 75 Integration Events Table

#	Event	Start Time	Stop Time	Value
1	<input checked="" type="checkbox"/> Width	0.000	0.000	0.2
2	<input checked="" type="checkbox"/> Threshold	0.000	0.000	50
3	<input checked="" type="checkbox"/> Threshold	0.152	1.857	817
4	<input checked="" type="checkbox"/> Width	1.915	2.173	0.258664
5	<input checked="" type="checkbox"/>			

Notice

Extreme values of both Width and Threshold (too large or too small) can result in peaks not detected. Additionally, some data may require specific timed events (such as Valley-to-Valley or Tangent Skim) to fully optimize the integration. Details on how these events work are provided in the Online Help.

27. To Save the Integration Events with the Method, click the Save button on the Tool Bar, and select Save Method.

Create a Peak Table

The Peak Table section of the method includes a list of peak names and their retention time for identification purposes. This table is also used to enter the concentrations for each standard mixture when generating a calibration curve. Peak information can be entered into the Peak Table graphically using a stored standard data file.

1. With the Tutorial Data 1 file open and analyzed in the instrument window, select Define Peaks from the Graphical Integration Tool bar at the bottom of the Instrument Window.

Notice

The tools can be identified by the caption in the Left Status bar (at the bottom left of the Instrument window) or the Tool Tips pop-up message. To see either of these, hold the cursor over the button.

Figure 76 The Instrument window's Graphical Integration toolbar.

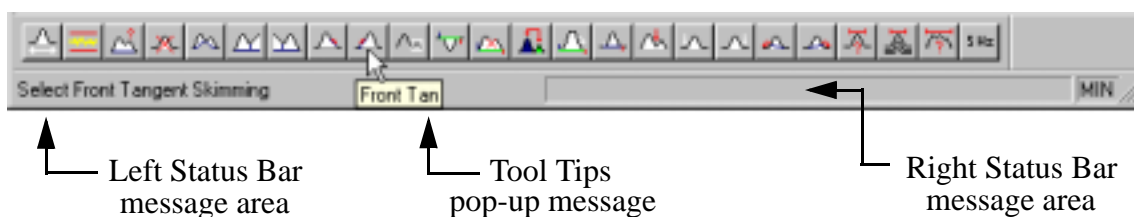

Figure 77 Define Peaks button.



2. As you move the cursor over the chromatogram, the arrow will turn into a "+" sign accompanied by a moving vertical bar which is used to set the location of the graphical integration function selected. When no integration function is selected, this cursor can also be used to select and zoom in on any area of the chromatogram.

3. The prompt “Click the beginning of the range of peaks you want to define” will appear in the Right Status bar.
4. Click the mouse to the left of the first standard peak in the chromatogram.

Figure 78 Defining Peaks - Click the beginning of the range of peaks you want to define.

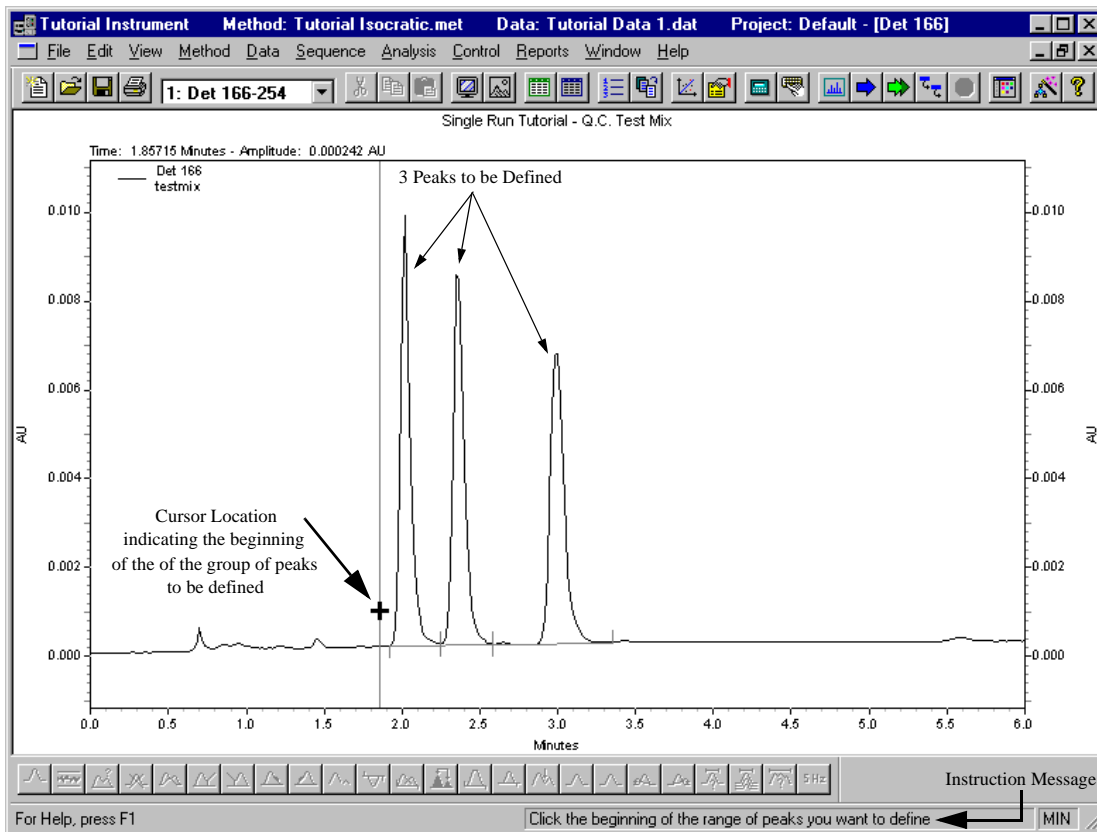

5. After you have clicked on the location of the start of the first peak in the group, the Right Status bar will display the message "Click the end of the range of peaks you want to define".
6. Click the mouse to the right of the last standard peak in the chromatogram.

Figure 79 Defining Peaks - Click the end of the range of peaks you want to define.

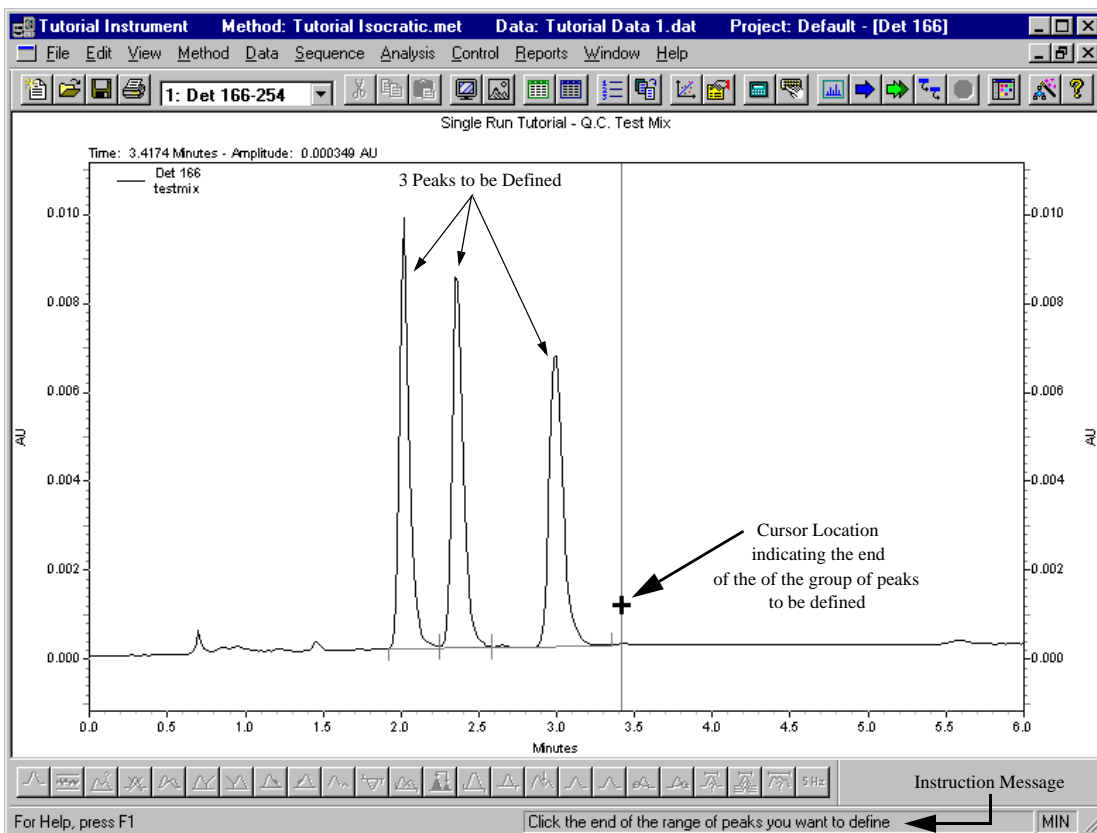

7. After you have clicked on the location of the end of the last peak in the group, the 32 Karat Software will generate a Peak Table that includes the detected peaks within the specified range, along with retention times for each. and displays the following dialog box:

Figure 80 Define Peaks Dialog.

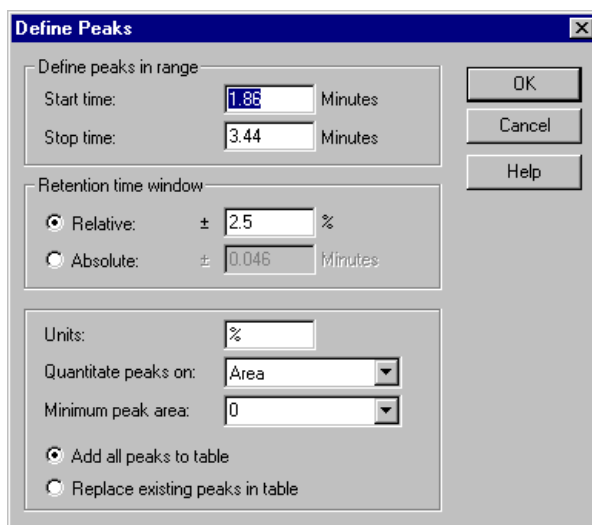

8. In the Define Peaks dialog, the time range you specified will be entered in the Time fields. If needed, you may change these times manually in the boxes shown.
9. The Retention Time window values set a window around the expected retention time of peaks. These values can be either Relative or Absolute.
10. For this tutorial, keep the Relative Retention Time Window value of +/- 2.5% of the retention time, which is specified.
11. Accept all other defaults for now and click OK.

Notice

Additional information on setting the parameters for the Define Peaks dialog can be found in the Online Help.

12. From the Method menu select Peaks / Groups to open the Peak Table.
13. Make sure that the 166 Detector (Det 166-254) is selected in the channel selection pull-down menu located on the Tool bar.

Figure 81 Newly generated peak table.

#	Name	ID	Ret. Time	Window	Ref. ID #	ISTD. ID #	Resolution ID #	Units	RT Update
1	Peak @ 2.383	1	2.38333	0.119167	0	0	0 %	None	
2	Peak @ 2.750	2	2.75	0.1375	0	0	0 %	None	
3	Peak @ 3.083	3	3.08333	0.154167	0	0	0 %	None	
4									

14. Assign peak names by typing each component name next to its retention time.

Figure 82 Peak names entered 1. Methyl Paraben, 2. Ethyl Paraben, 3. Propyl Paraben.

#	Name	ID	Ret. Time	Window	Ref. ID #	ISTD. ID #	Resolution ID #	Units	RT Update
1	Methyl Paraben	1	2.38333	0.119167	0	0	0 %	None	
2	Ethyl Paraben	2	2.75	0.1375	0	0	0 %	None	
3	Propyl Paraben	3	3.08333	0.154167	0	0	0 %	None	
4									

15. There are more columns in the Peak Table than can be displayed in the window. To view the columns not shown on the spreadsheet, click on the arrows on the scroll bar at the bottom of the spreadsheet.
16. To save the Peak Table with the Method, click the Save button on the Tool Bar, select Save Method.

This completes the “Optimizing a Method” section of the User's Guide.

Section 8 - Calibration



Introduction

In chromatography, peak area and peak height are directly related to concentration. By injecting known concentrations of standards, a method can be calibrated to provide quantitative information about samples in which the concentration is unknown.

This exercise will detail the calibration of the Tutorial Isocratic method using either a single point calibration or multi-point calibration. In a single point calibration a single standard of known concentration is injected. A calibration curve is generated based on the assumption that the graph will pass through zero. A multi-point calibration uses a series of standards to generate a calibration curve. The objectives of this exercise are to:

- Edit the peak table for a calibration.
- Run a calibration standard or series of standards.
- View the resulting calibration curve.
- Acquire an unknown sample.
- Review the report with quantitative information included.

Single Point Calibration

In this example, we will set up and run a calibration standard.

Editing the Peak Table

The first step in running a calibration is entering concentration information for each peak in the Peak ID table.

1. Open the method Tutorial Isocratic. From the method menu, select Peak / Groups.
2. Scroll to the right until you see the column labeled “Fit Type.”
3. Because this is a single-level calibration, this column must be set to point-to-point.
4. A linear fit requires two calibration points, quadratic fits require three calibration points, etc.

Figure 83 Peak ID Table with point to point selected as fit type.

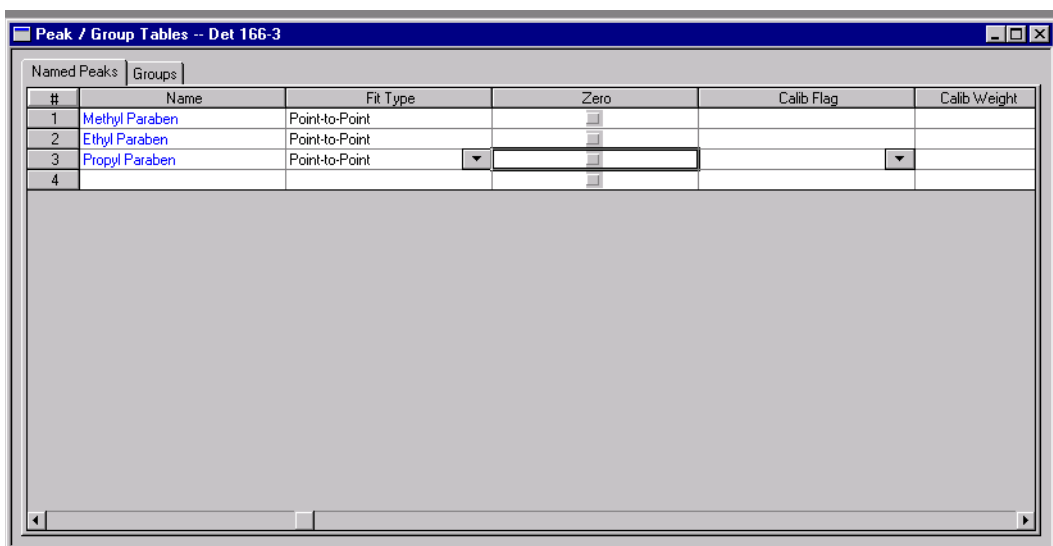

#	Name	Fit Type	Zero	Calib Flag	Calib Weight
1	Methyl Paraben	Point-to-Point			
2	Ethyl Paraben	Point-to-Point			
3	Propyl Paraben	Point-to-Point			
4					

5. Scroll to the right until you see the column labeled “Level 1.”
6. Enter the concentration of each peak in your standard mixture.
7. For the purpose of this tutorial enter 100 as the concentration of each paraben.

Figure 84 Peak ID with concentration information entered.

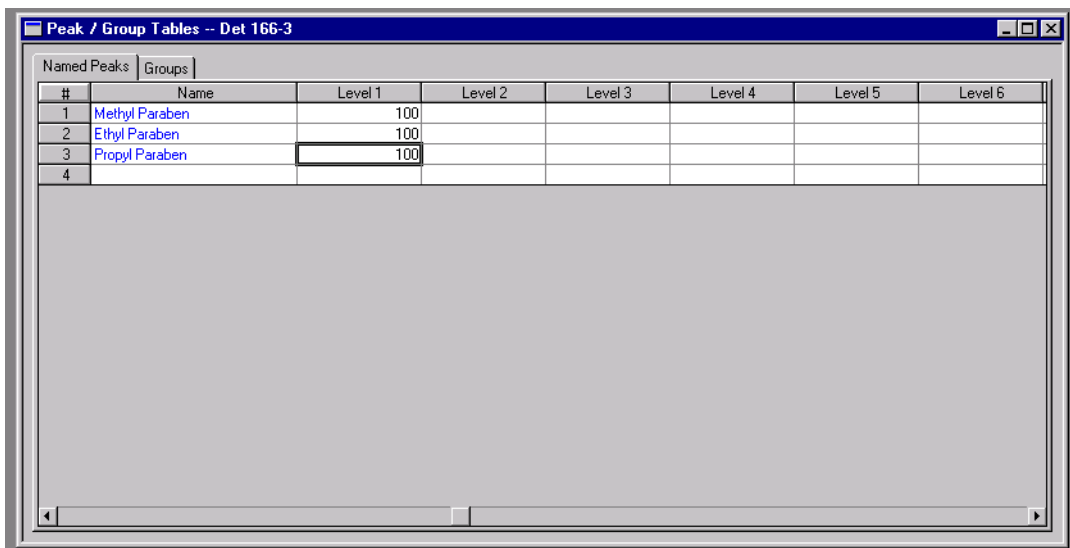

The screenshot shows a software window titled "Peak / Group Tables -- Det 166-3". It contains a table with the following data:

#	Name	Level 1	Level 2	Level 3	Level 4	Level 5	Level 6
1	Methyl Paraben	100					
2	Ethyl Paraben	100					
3	Propyl Paraben	100					
4							

8. To save the method with the new Peak Table information, click on the Save icon on the Tool bar and select Save Method.

Running the Calibration Sample

1. Click on the Single Run button (Control/Single Run).
2. The following dialog is displayed.

Figure 85 Single run dialog.

Single Run Acquisition

Run information

Sample ID:

Method:

Data path:

Data file:

Number of runs: Print method report

Amount values

Sample amount:

Internal standard amount:

Multiplication factors:

Dilution factors:

Autosampler

Vial:

Injection volume:

Tower:

Calibrate

Calibration level:

Clear all calibration

Clear calibration for level

Print calibration report

Clear replicates

Average replicates

Startup

Shutdown

Begin run

3. Type “Tutorial 1 Point Cal” in the Sample ID field.
4. Click on the browse button next to the Method Name field and select Tutorial Isocratic.met from the list of available methods shown.
5. Type “Single Point Cal” in the Data File field.
6. Enter the position number of the calibration standard in the Vial field.
7. Enter the volume of sample to be injected in the Sample Volume field. For the purpose of this tutorial enter 20 μ L.

8. Click on the Calibrate check box and enter 1 in the Calibration Level field.
9. The Acquisition dialog on your computer should look like the following:

Figure 86 Single Run dialog with the above information entered.

10. Click on Start when ready to inject the standard sample.
- 32 Karat Software updates the method after the calibration run is complete, entering the area values (or heights) into a calibration curve for calculation of response factors for each component.

Notice

The Single Run Acquisition window contains three input fields next to each of the Multiplication factors and Dilution factors parameters (see figure 86). The values entered into each of these three fields are multiplied together to give the total multiplication factor or dilution factor made to the sample. Alternatively, you can simply input the total multiplication or dilution value (if any were made to your sample) into one of the three fields and leave the values for the two remaining fields equal to “1”. For more information, refer to the Online Help.

Multi-Point Calibration

Editing the Peak Table

The first step in running a calibration is entering concentration information for each peak in the Peak ID table.

1. Open the method Tutorial Isocratic.
2. From the method menu, select Peak / Groups.
3. Scroll to the right until you see the column labeled "Fit Type."
4. Because this is a multi-point calibration, this column can be set to linear.
5. A linear fit requires at least two calibration points, quadratic fits require at least three calibration points, etc.

Figure 87 Peak ID Table with linear selected as fit type.

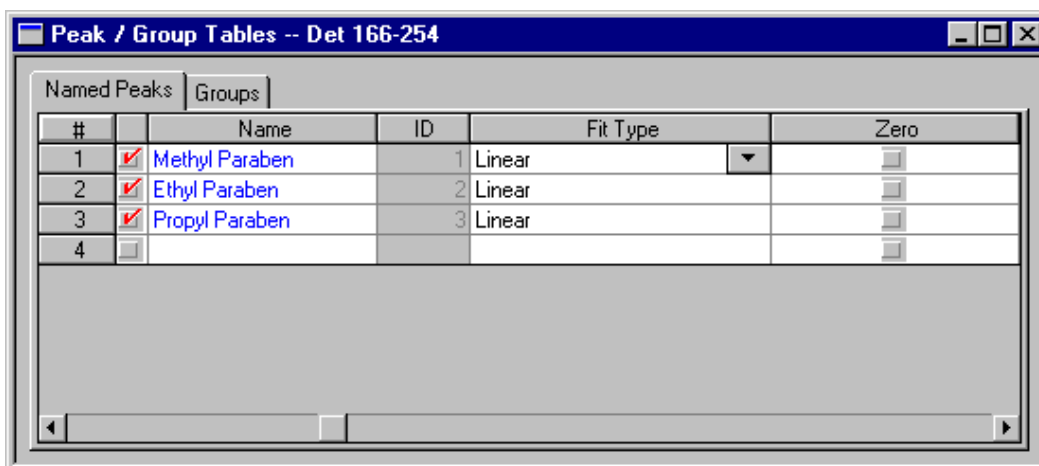

#		Name	ID	Fit Type	Zero
1	<input checked="" type="checkbox"/>	Methyl Paraben	1	Linear	<input type="checkbox"/>
2	<input checked="" type="checkbox"/>	Ethyl Paraben	2	Linear	<input type="checkbox"/>
3	<input checked="" type="checkbox"/>	Propyl Paraben	3	Linear	<input type="checkbox"/>
4	<input type="checkbox"/>				<input type="checkbox"/>

6. Scroll to the right until you see the columns labeled Level 1, Level 2, etc.
7. Enter the concentration of each peak in the standard mixture for each level in the calibration curve.
8. Level 1 should correspond to the lowest concentration.
9. For the purpose of this tutorial enter 5 in the Level 1 column for each peak in the Peak ID table.
10. Enter 10 in the Level 2 column for each peak in the Peak ID table.
11. Enter 20 in the Level 3 column for each peak in the Peak ID table.

Figure 88 Peak ID with concentration information entered.

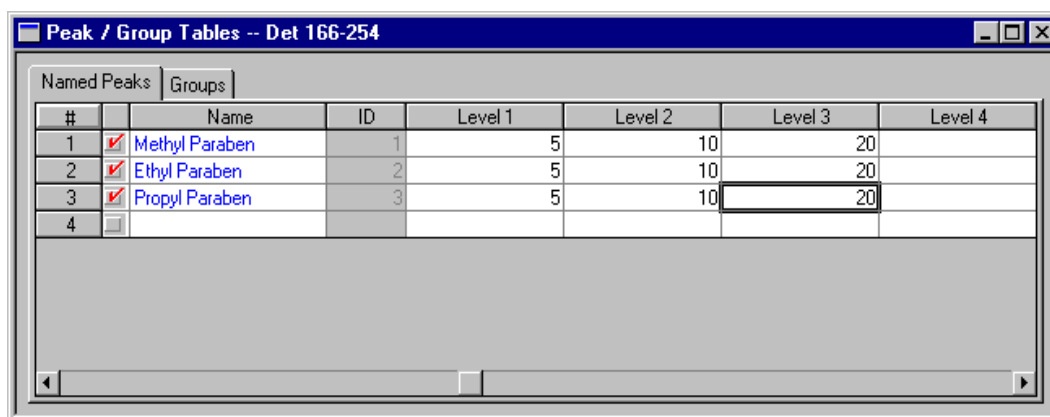

#	Name	ID	Level 1	Level 2	Level 3	Level 4
1	<input checked="" type="checkbox"/> Methyl Paraben	1	5	10	20	
2	<input checked="" type="checkbox"/> Ethyl Paraben	2	5	10	20	
3	<input checked="" type="checkbox"/> Propyl Paraben	3	5	10	20	
4	<input type="checkbox"/>					

12. To save the method with the new Peak Table information, click on the Save icon on the Tool bar and select Save Method.

Creating a Calibration Sequence

A multi-point calibration must be run as a sequence. In this exercise you will create a calibration sequence.

1. Click on File / Sequence / Sequence Wizard.
2. In the Sequence Wizard - Method dialog click on the browse button next to the Method field.
3. Select Tutorial Isocratic.met from the Open Method File dialog.

Figure 89 Open method file dialog with Tutorial Method selected.

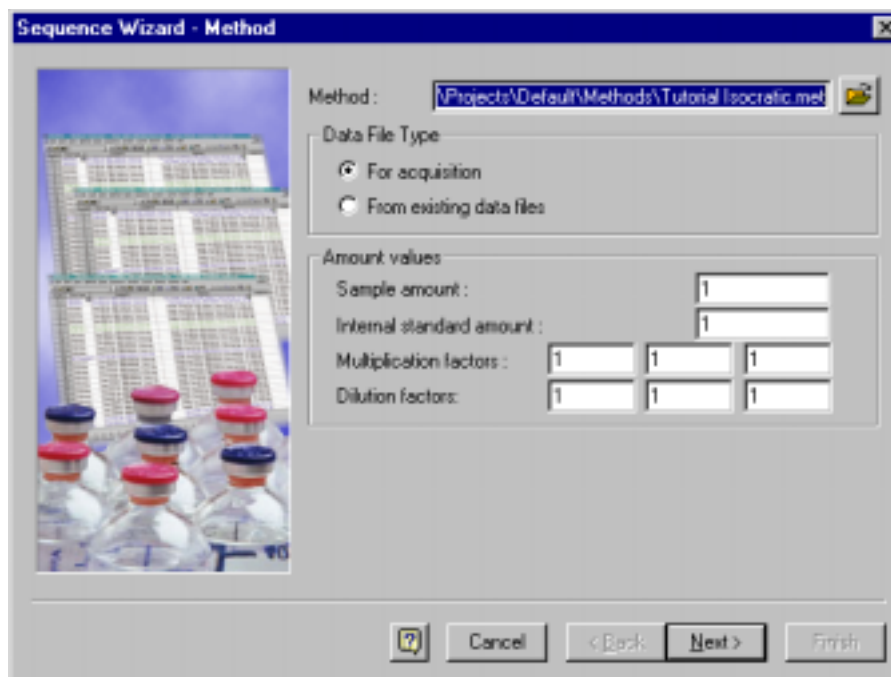

4. Click Next.
5. In the Sequence Wizard - Unknowns dialog we will not make any changes. Click Next.
6. In the Sequence Wizard - Autosampler dialog we will not make any changes. Click Next.
7. In the Sequence Wizard - Calibration dialog enter "Multi-point Calibration Data" in the Calibration ID field.
8. Type "Multi-Point Data" in the Calibration File field. Then click the blue arrow at the end of the Calibration File Field. Select Increment Number.

9. Enter “3” in the Number of levels field.

Figure 90 Sequence Wizard - Calibration dialog with the above info entered.

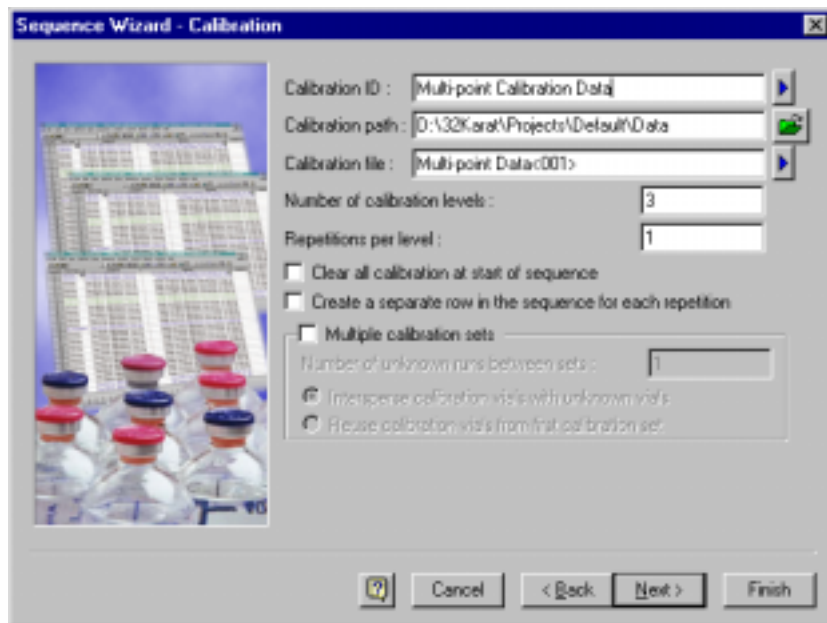

10. Click Finish.
11. The remaining Sequence Wizard dialogs are discussed in other exercises.
12. The Sequence should look like the one below:

Figure 91 New sequence.

Run #	Status	Run Type	Level	Conc Override	Reps	Vial	Volume	Sample ID	Method	Filename
1		Calibration	1		1	1	30	Multi-point Calibration	Tutorial Isocratic.met	Multi-point Data001
2		Calibration	2		1	1	30	Multi-point Calibration	Tutorial Isocratic.met	Multi-point Data002
3		Calibration	3		1	1	30	Multi-point Calibration	Tutorial Isocratic.met	Multi-point Data003
4		Unknown	0	n/a	1	2	30		Tutorial Isocratic.met	
5										

13. For the purpose of this tutorial we will inject three different volumes from the same sample vial to simulate the three different levels of calibration.
14. In each line of this sequence enter a 1 in the Vial column of the sequence.
15. In line 1 of the sequence enter 5 in the Volume (μL) column.
16. In line 2 enter 10 in the Volume (μL) column.
17. In line 3 of the sequence enter 20 in the Volume (μL) column.
18. Enter the vial position.

Figure 92 New information entered.

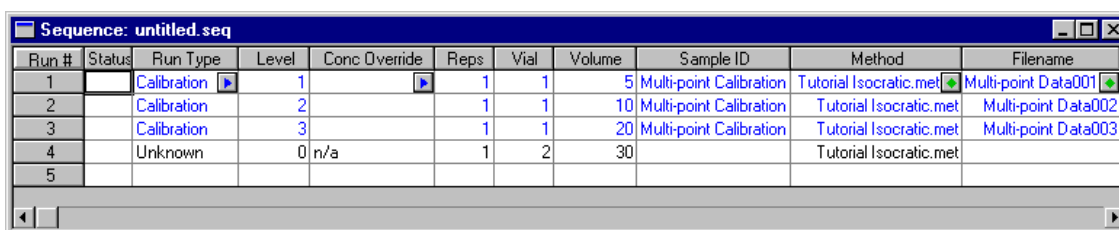

Run #	Status	Run Type	Level	Conc Override	Reps	Vial	Volume	Sample ID	Method	Filename
1		Calibration	1		1	1	5	Multi-point Calibration	Tutorial Isocratic.met	Multi-point Data001
2		Calibration	2		1	1	10	Multi-point Calibration	Tutorial Isocratic.met	Multi-point Data002
3		Calibration	3		1	1	20	Multi-point Calibration	Tutorial Isocratic.met	Multi-point Data003
4		Unknown	0	n/a	1	2	30		Tutorial Isocratic.met	
5										

Note

In an actual calibration three different standards of known concentration would be prepared. The concentrations of the standards should correspond to the concentrations entered in the Levels columns in the Peak ID Table.

19. To Save the Sequence click on the Save button on the Tool bar and select Sequence.
20. Enter "Multi-point Sequence" in the Save Sequence File As dialog.
21. Click Save.

Running the Calibration Sequence

1. Click on the Sequence Run button (Control/Sequence Run).
2. The following dialog is displayed.

Figure 93 Sequence run dialog.

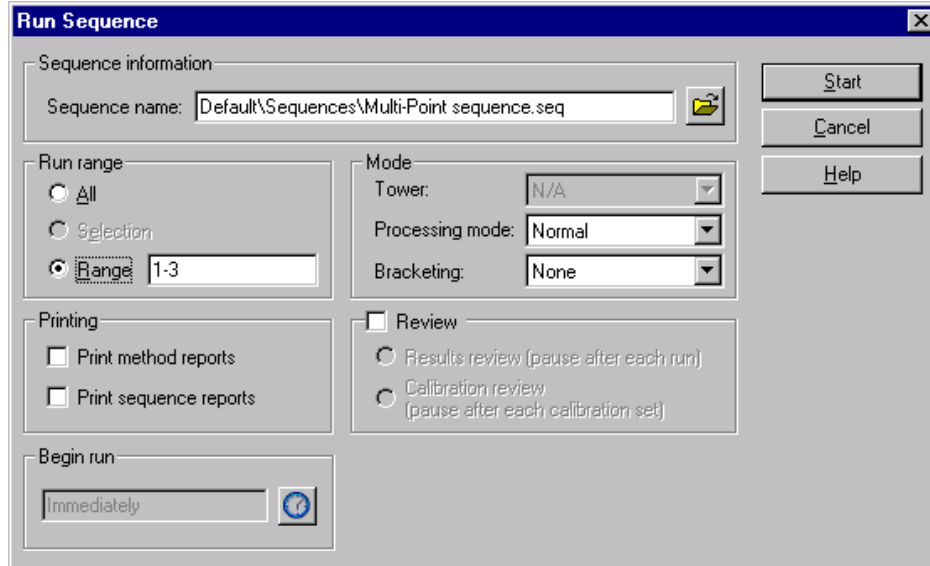

3. Enter the sequence name and designate the Range as "1-3".
4. Click on Start when you are ready to start your calibration sequence.

32 Karat Software updates your method after your calibration sequence run is complete, entering the area values (or heights) into the calibration curve for calculation of response factors for each component.

View the Calibration Curve

After your method has been calibrated, you can view the calibration curves for each sample component.

1. From the Method menu select Review Calibration....
2. The following window appears with the list of the components in your method's Peak ID Table displayed in the "Peak List" box.

Figure 94 Review calibration curve window.

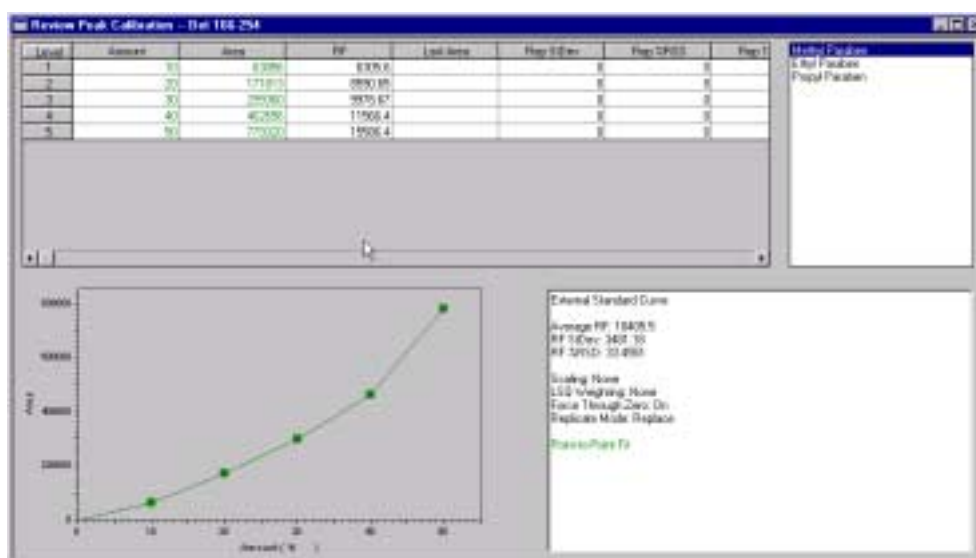

3. To view the calibration curve for any component, simply click on the component name in the "Peak List" box.
4. The number of points in the calibration curve will be based on whether the calibration was single or multiple point.

For more details on options for viewing calibration curves, see the Review Peak Calibration Curve section in the Online Help.

Acquire an Unknown Sample

Now acquire an “unknown” sample and generate a report containing quantitative information based on the calibration you just performed.

1. Click on the Single Run button (Control/Single Run). A dialog box appears prompting for information to use in acquisition and processing of the run.
2. Type “Unknown” in the Sample ID field.
3. In the Method field, use the browse button to select Tutorial Isocratic.met.
4. Type “Unknown Data” in the Data File field. This will be the name of the data file for the unknown sample.
5. Specify the vial position of the unknown sample and the injection volume (in this example, 10).
6. The Acquisition dialog on the computer should look like the following:

Figure 95 The Acquisition dialog

The screenshot shows the 'Single Run Acquisition' dialog box with the following settings:

- Run information:** Sample ID: Unknown; Method: Projects\Default\Methods\Tutorial Isocratic.met; Data path: D:\32Karat\Projects\Default\Data; Data file: Unknown Data; Number of runs: 1; Print method report; Calibrate; Calibration level: 1.
- Amount values:** Sample amount: 1; Internal standard amount: 1; Multiplication factors: 1, 1, 1; Dilution factors: 1, 1, 1.
- Autosampler:** Vial: 2; Injection volume: 10; Tower: N/A.
- Right side controls:** Startup; Shutdown; Begin run: Immediately; Buttons: Start, Cancel, Help, Description...

7. When ready to inject the sample, click on Start.

8. When the data acquisition is complete, from the Reports menu select View / Method Custom Report.
9. The custom report should now include quantitative information in the ESTD Concentration column of the run report.

Notice

In order to view or print a Method Custom Report, a report template must be created and saved with the method. See section 9 of this manual or the Online Help for more information.

Figure 96 Custom report with concentration information included.

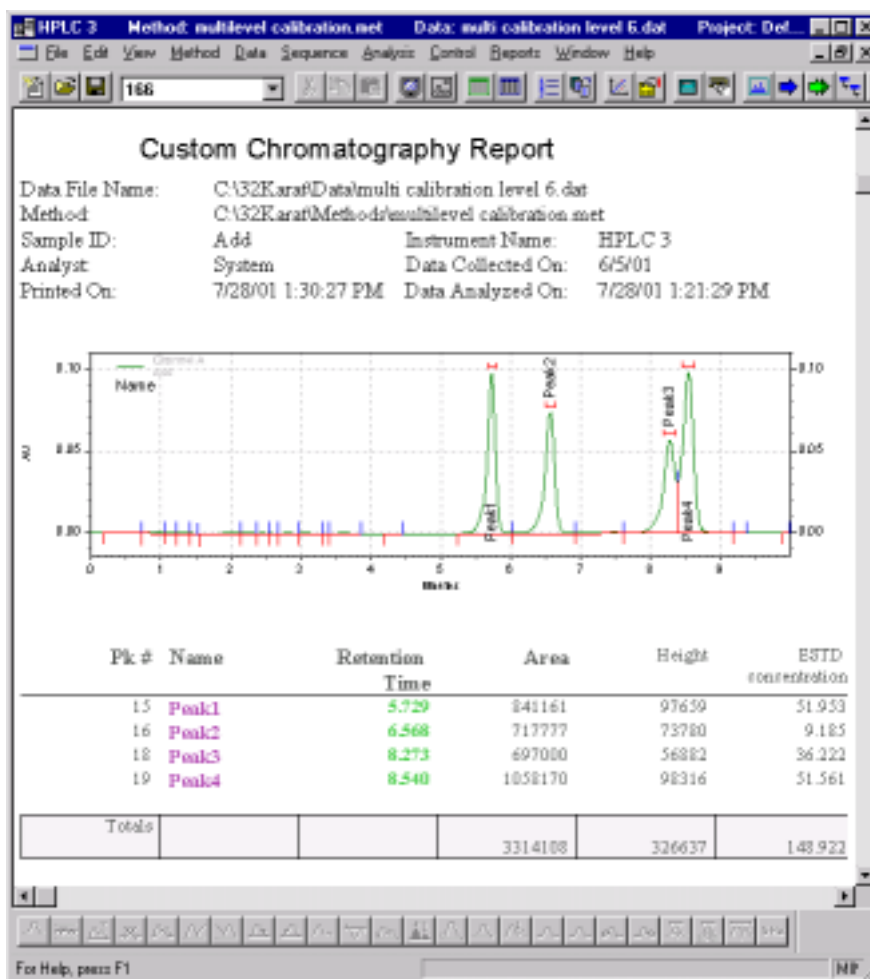

10. Quantitative information is also available in the pre-formatted External Standard Report.
11. To open this report, from the Report Menu select View / External Standard.

Figure 97 External Standard report.

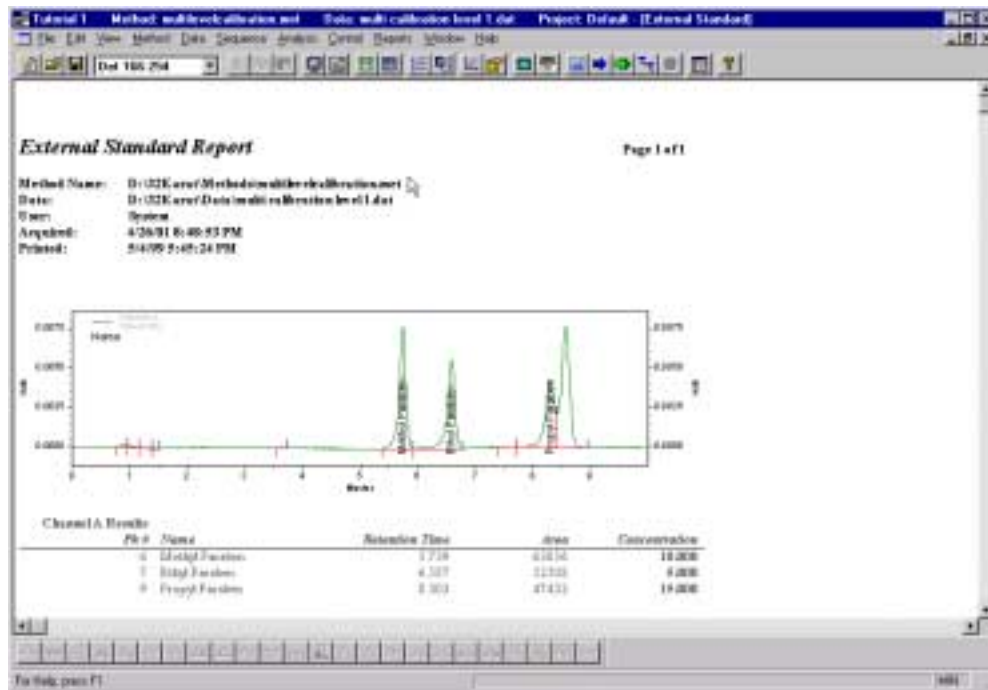

This completes the Calibration section of the User's Guide.

Section 9 - Creating Reports



Introduction

One of the most important aspects of using a chromatography data system is getting the results into a useful format. While use of default standardized report formats is handy, often a standard report doesn't include enough information, or contains unnecessary information. The 32 Karat Software Custom Report editor allows the creation of completely customized reports to include only the wanted information, presented in the most efficient way.

This exercise will show how to:

- Add field information to the method custom report.
- Add a chromatogram to the method custom report.
- Add a result table to the method custom report.
- Save the method custom report as a template.

Getting Started

Before beginning the Method Custom Report formatting, open the method and data file created in earlier exercises.

1. Click on the Open button on the tool bar.
2. Select Open Data.
3. In the Open Data File dialog box select Tutorial Data 1. **ALSO** in the options focus area, click the Method pull-down menu and select Original/Acquisition. This will open the method with which this data file was collected.

Figure 98 Open Data File dialog with data file selected and Open With Method selected.

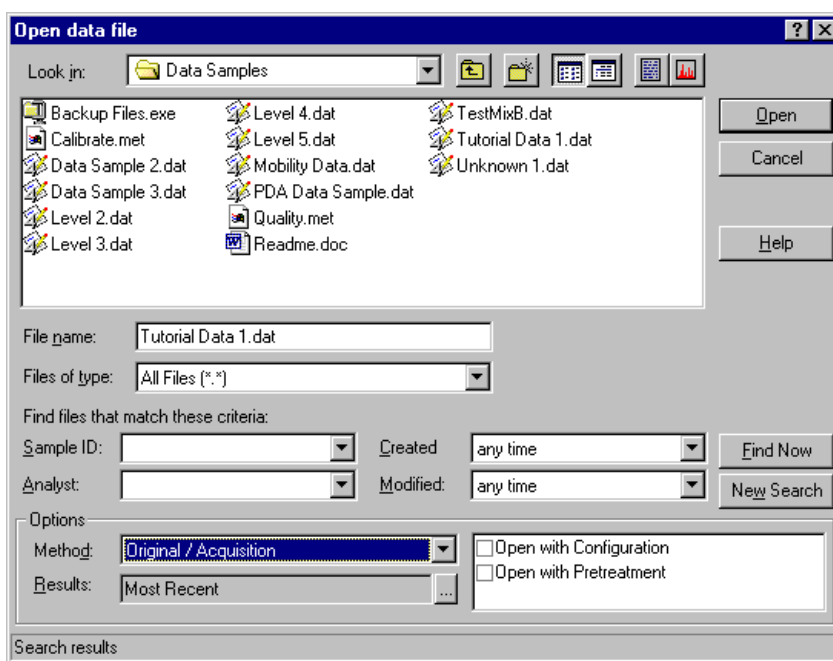

4. Click on the Open button.

The Method Custom Report Window

1. From the Method menu, select Custom Report.
2. A method custom report window will be displayed.
3. This window has the look and feel of a word processing program with many of the common tools.

Figure 99 Empty custom report window.

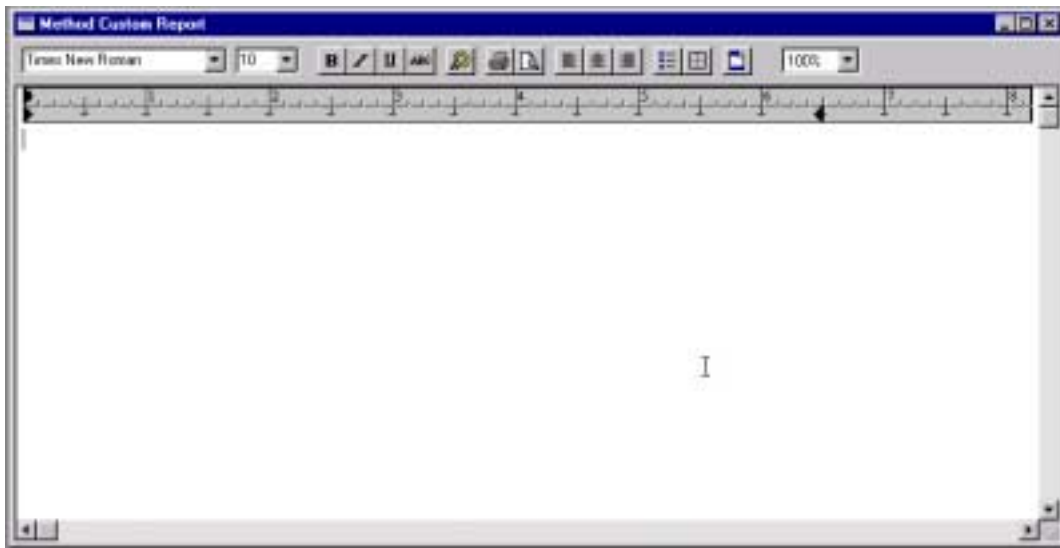

Adding Field Information

This exercise will show how to add data file information to the report.

1. Select a location at the top of the report window and type “Chromatography Method Custom Report”. Text entered in the custom report will appear in the location it was typed.
2. Hit the Enter key twice to move the cursor down the page.
3. Type “Data File Name:” then press the tab key.
4. Click the right-hand mouse button.
5. The following menu will be displayed:

Figure 100 Right mouse click menu.

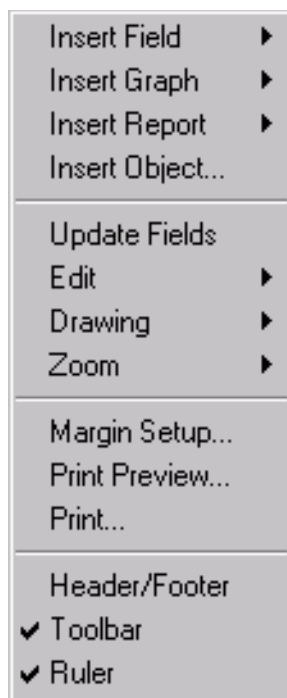

6. Click the Insert Field command.

- The following menu of Field items will be displayed:

Figure 101 Add Field menu.

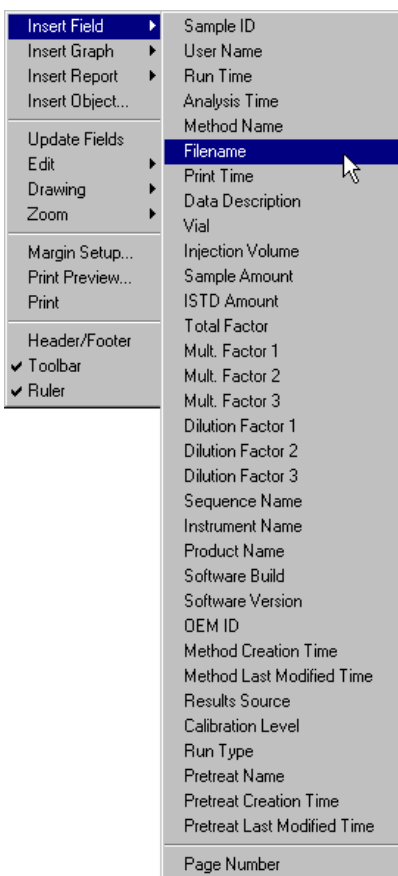

- Select Filename. A shaded field with {Filename} will appear. This field will update to display the filename information for the data file when this report is printed.
- Hit the Enter key.
- Type “Method Name:” then press the tab key.
- Click the right-hand mouse button anywhere in the report area.
- Click the Insert Field command.
- Select Method Name. A shaded field with {Method Name} will appear. This field will update to display the Method Name that was used to collect the data file when this report is printed.
- Hit the Enter key.
- Type “Sample ID:” then press the tab key.

16. Click the right-hand mouse button anywhere in the report area.
17. Click the Insert Field command.
18. Select Sample ID. A shaded field with {Sample ID} will appear. This field will update to display the Sample ID for the data file when this report is printed.
19. Hit the Enter key.
20. Following the same process add the following text and fields to the Custom Report:

Sample ID:	{Sample ID}	Instrument Name:	{Instrument Name}
Analyst:	{User Name}	Data Collected On:	{Run Time}
Printed On:	{Print Time}	Data Analyzed On:	{Analysis Time}

21. Right mouse click on the report and select Update Fields.
22. The Custom Report should appear as below:

Figure 102 Custom Report with above information added.

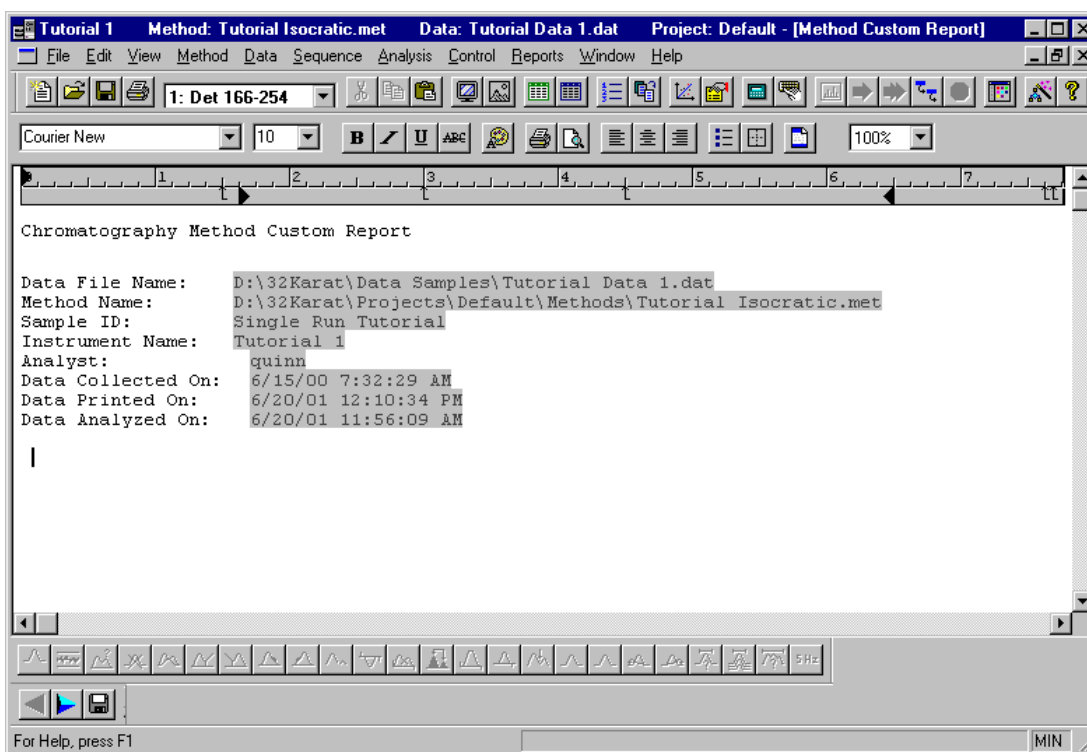

To save the report click on the Save button on the Tool bar, then select Save Method.

Formatting the Report Text

Use the Tool bar to format the text of the custom report.

1. Highlight the Report Title - Chromatography Method Custom Report.
2. Center the text in the page by clicking on the center justify button on the tool bar.
3. Select Arial as the Font type.
4. Select 14 as a font size.
5. Select red as a text color.
6. The Custom Report should appear as below:

Figure 103 Custom Report with above information added.

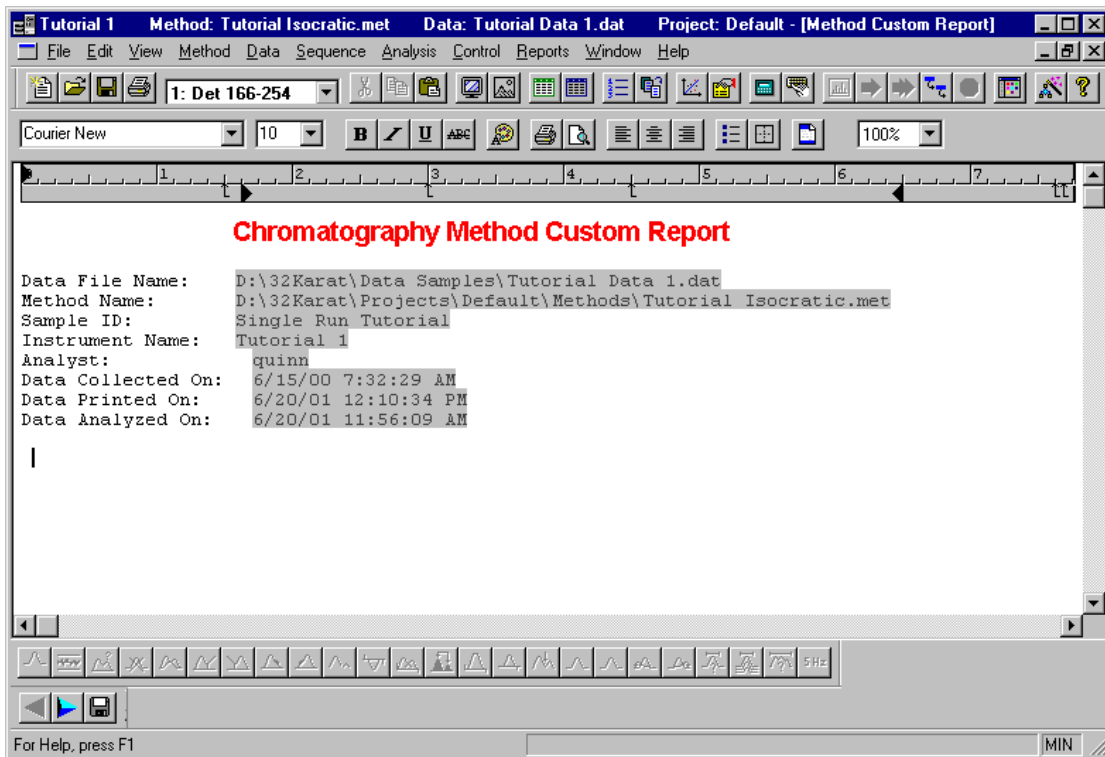

To save the report click on the Save button on the Tool bar, then select Save Method.

Adding a Chromatogram to the Report

1. Hit the Enter Key to move the cursor down the report page.
2. Click the right-hand mouse button anywhere in the report area.
3. Select Insert Graph, then Data Graph.
4. The following dialog will open.

Figure 104 Add Trace dialog.

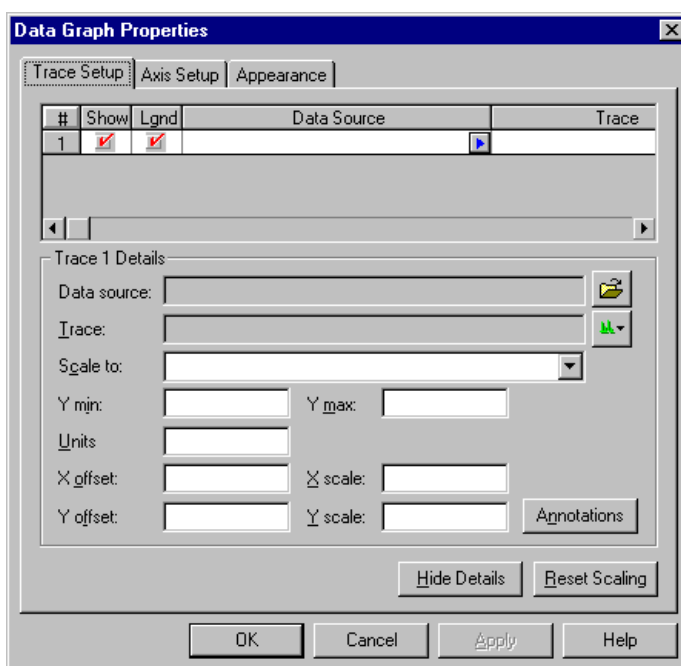

5. On the Trace Setup tab click on the blue arrow in the Data Source column and select Current Data. Click OK.

Figure 105 Menu items open.

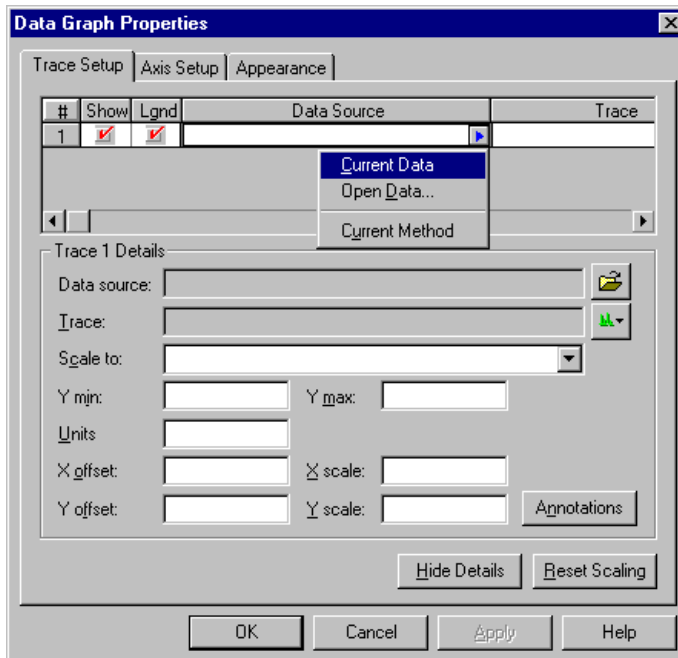

- A graph with the Tutorial Data 1 data file should now appear on your custom report.

Figure 106 Custom report with the data file open.

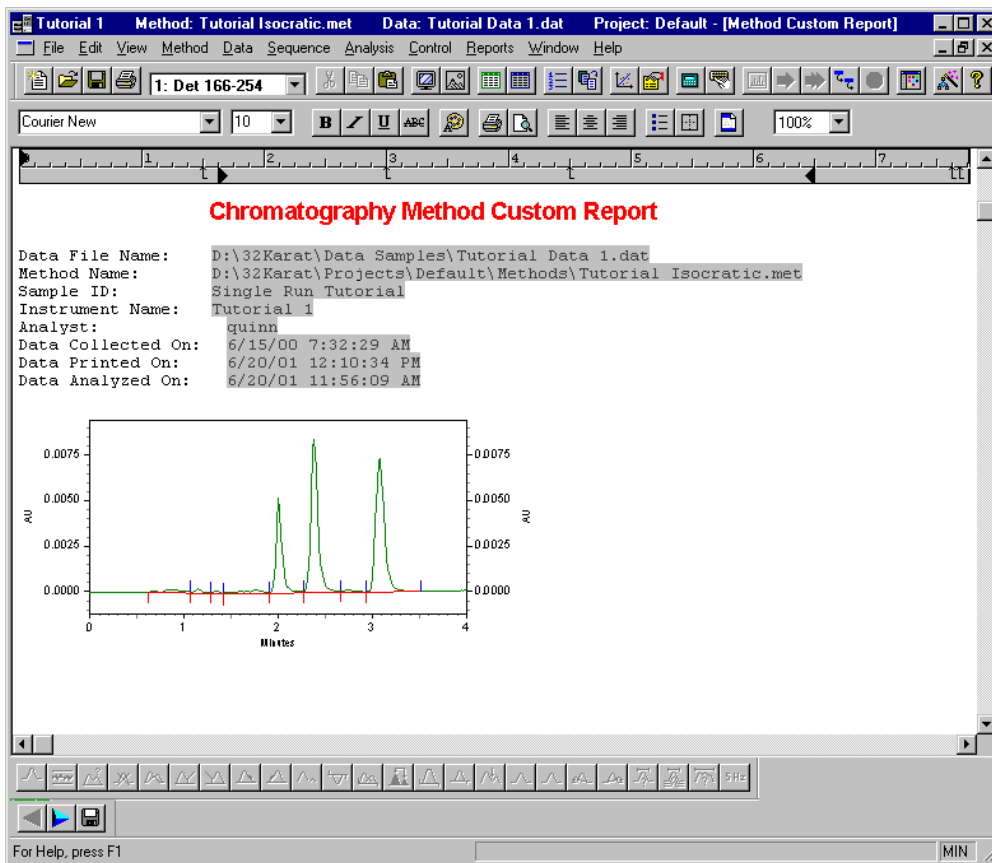

- Stretch the graph to cover the width of the report by clicking on the black square at the lower right corner of the graph window and dragging down and to the right until it fills the width of the report.

8. To edit the chromatogram properties, double click on the graph.
9. The Data Graph Properties window will be displayed.
10. Within this window, you can make changes to the appearance and display properties of the chromatogram.
11. Click on the Annotations button Trace Setup tab of the Data Graph Properties window. This will open the Trace Annotation Properties dialog.
12. Select “Retention Time” from the “Available Annotations” frame and move it to the “Show the following annotations” frame by clicking on the green arrow.
13. Click Apply then OK to return to the Data Graph Properties window.
14. Click Apply then OK again to return to the Report window.

Figure 107 Properties dialog.

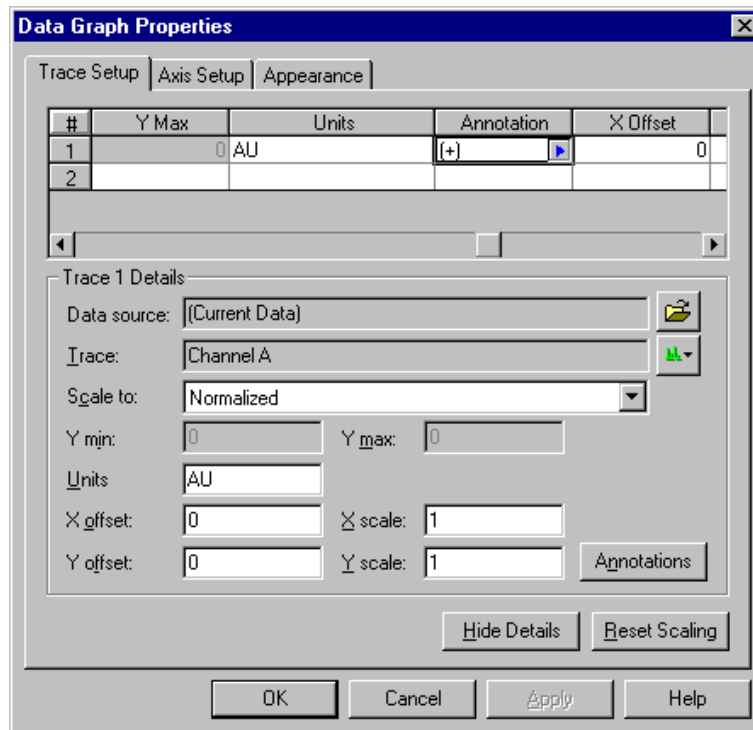

15. The Custom Report should appear as below:

Figure 108 Custom Report with above information added.

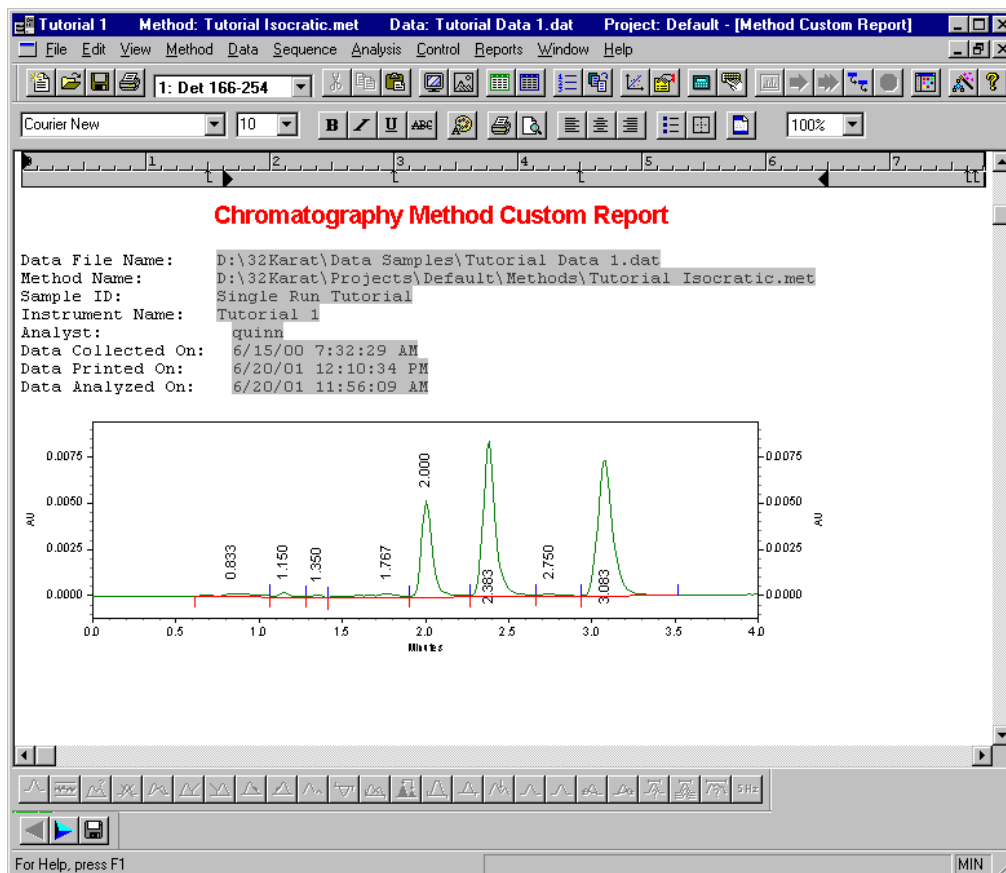

To save the report click on the Save button on the Tool Bar, then select Save Method.

Adding Report Tables

There are several report types that can be added to the custom report. This example will show how to add a Run Report.

1. Move the cursor to the right side of the chromatogram.
2. Hit the Enter key to move the cursor down the report page.
3. Click the right-hand mouse button anywhere in the report area.
4. Select Insert Report, then Run Report. The following dialog will open.

Figure 109 Run Report dialog

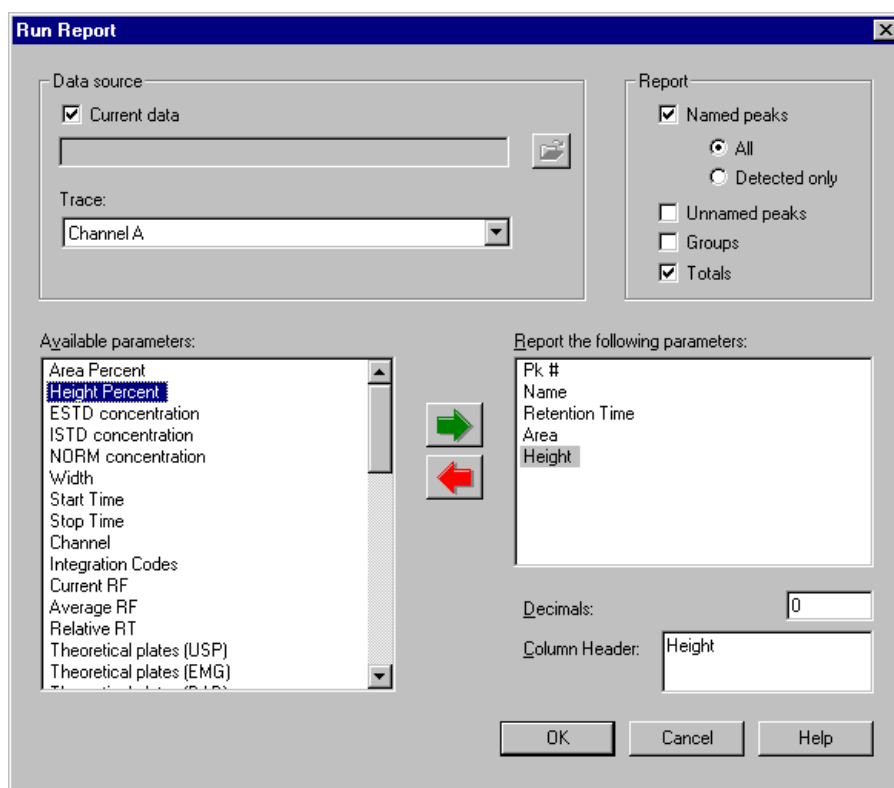

5. Click the Current Data check box.
6. From the “Available parameters” frame, select Pk#, Name, Retention Time, Area and Height and move them to the “Report the following parameters” frame by clicking on the green arrow.
7. Click OK to place the information within your report.

8. The Custom Report should appear as below:

Figure 110 Report with above information added.

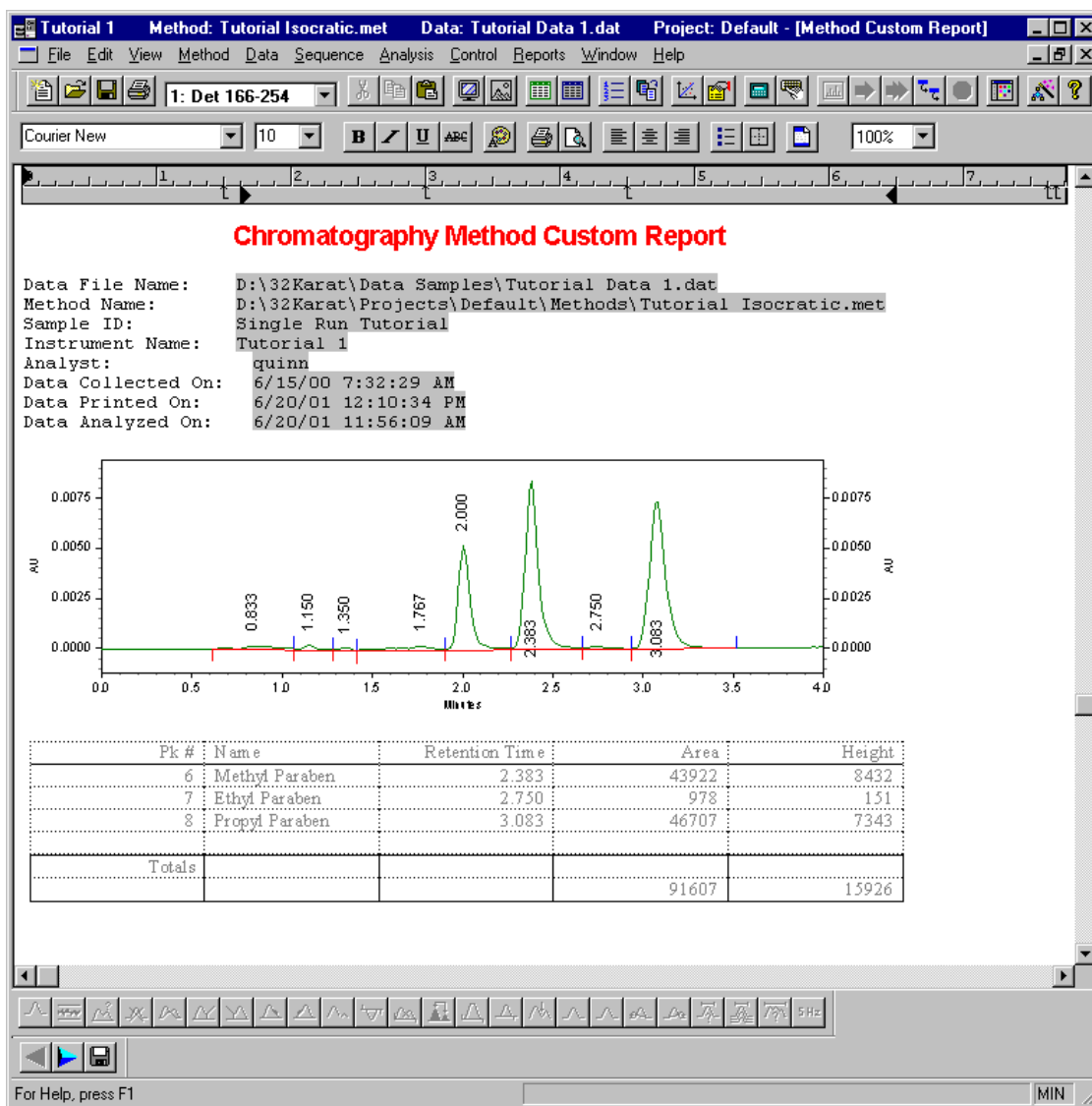

To save the report click on the Save button on the Tool Bar, then select Save Method.

Previewing the Method Custom Report

Once you have completed your method custom report format, you can preview how the report will look when printed, or generate a hard copy of the report.

1. From the Report menu select View / Method Custom Report.

Make sure the current chromatogram has been analyzed in order for results to be displayed in the custom report.

Figure 111 Preview screen.

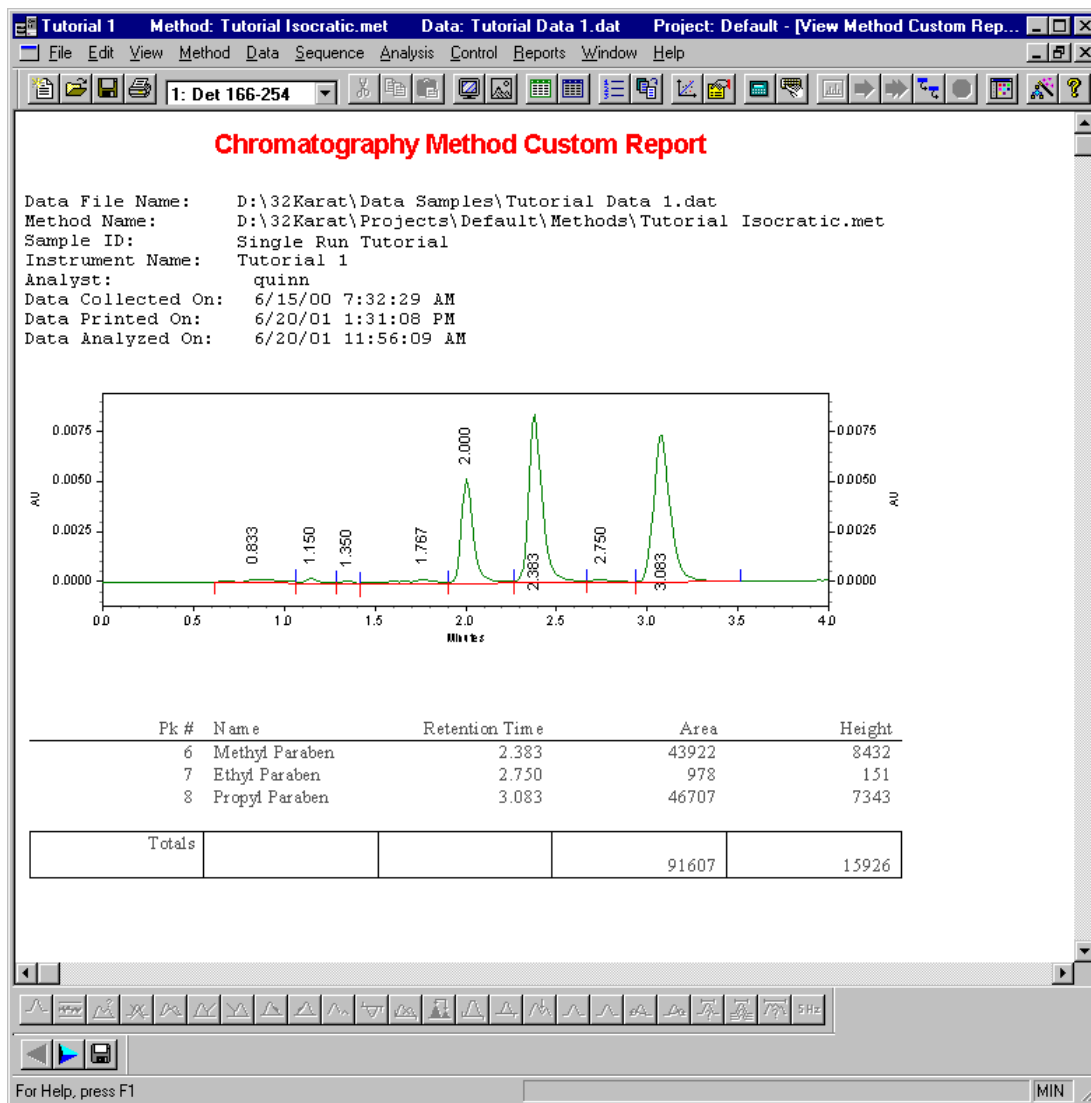

Save the Custom Report Format as a Template

With 32 Karat Software, a formatted custom report can be saved as a template that can be used in other methods.

1. With the formatted method custom report open, from the File menu select Report Template / Save As.

Figure 112 Report Template / Save As... menu items.

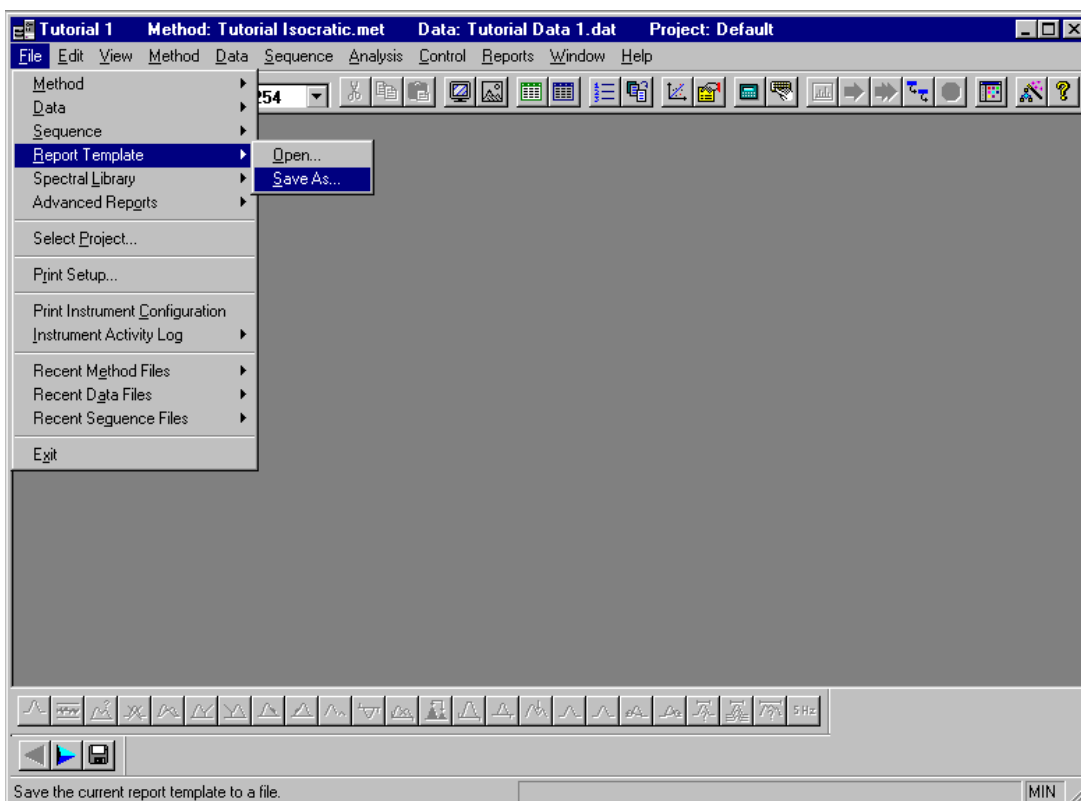

2. Enter “Tutorial Method Report Template” in the Save As dialog.

Figure 113 Save As dialog with above title entered.

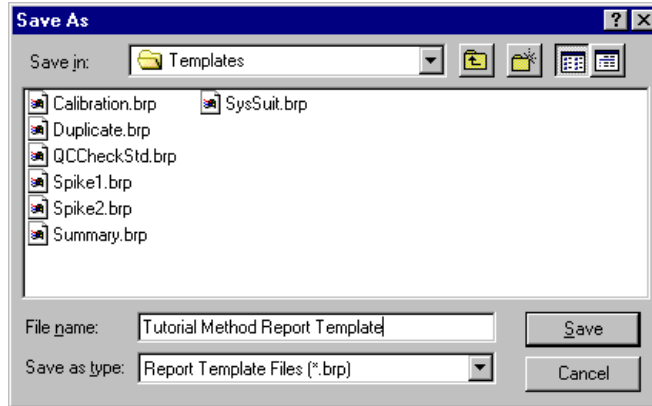

To use this template in another report:

1. With the new method open, from the File menu select Report Template / Open.

Figure 114 Report Template / Open menu items.

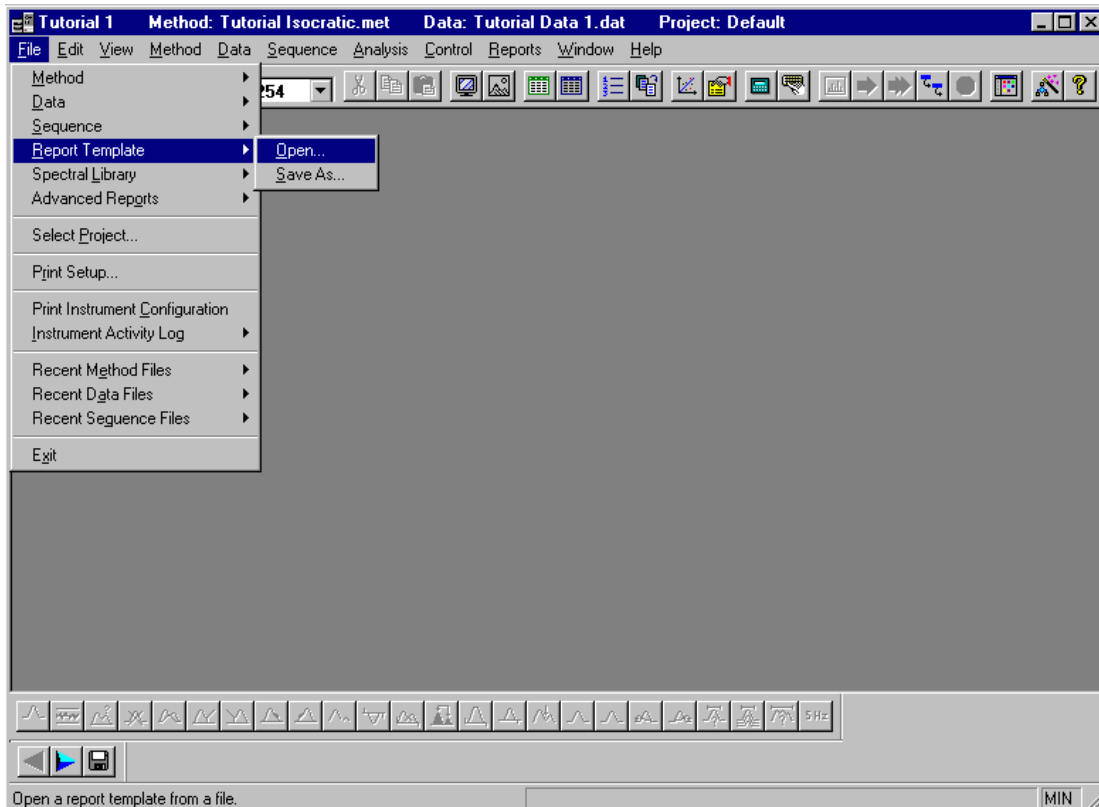

2. Select Tutorial Report Template then click OK.

Figure 115 Open dialog with above template selected.

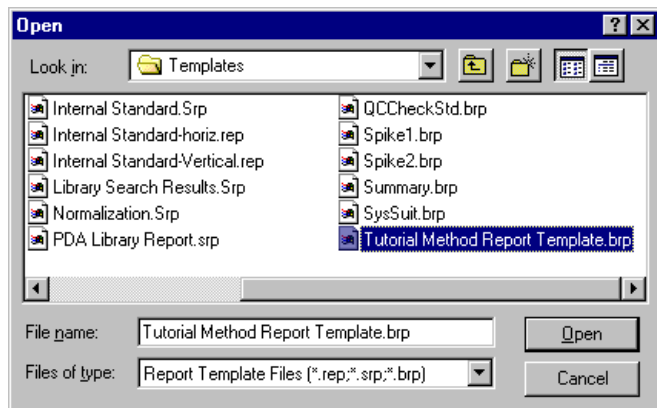

This formatted report will open within the new method.

This completes the Creating Reports section of the User's Guide.

Appendix 1

Additional Resources

32 Karat Online Help

The Online Help is your primary software reference for the 32 Karat Software. It describes all of the features used in this manual. In addition, it describes all of the advanced features which are not covered here. To access the Help, select **Help | Contents** from the instrument window menu bar. Context-sensitive help is available by selecting the Help button located in dialog boxes, or by pressing the **F1** key.

Installation and Maintenance Manual

The first place to look for answers to questions on hardware and maintenance is the Installation and Maintenance Manual. This document includes detailed descriptions of routine operations, such as instrument plumbing, and of non-routine operations such as minor repairs. A printed copy of this manual is shipped with the instrument. An electronic copy is available on the Manuals CD-ROM shipped with the 32 Karat Software.

Beckman Coulter Service

If you have determined that a problem exists with the instrument that can not be fixed by following the procedures in the Installation and Maintenance Manual, contact your local Beckman Coulter, Inc. Service Representative. There may be a charge for this service.

Help by e-mail

A special mailbox has been created for users of 32 Karat Software. Send your questions and comments to 32karat@beckmancoulter.com. A team of specialists will review your message and contact you. Messages received outside of regular business hours (Monday - Friday, 8:00 am to 5:00 pm Pacific Time) will be reviewed the next business day.

Other references

There are many publications dealing with applications of liquid chromatography, methodology, routine operations, and related techniques. Your local research library is the best place to begin.

Beckman Coulter web site. <http://www.beckmancoulter.com/> - *The online source for the latest information on HPLC from Beckman Coulter.*

Your Local Beckman Coulter Representative - *The best source for product information. Contact your representative for information on the latest products, or to place an order.*

Appendix 2

HPLC Calculations

32 Karat Software calculates several values that can be used to assess overall system performance. These values can be included in a custom report. The following diagram shows the parameters used to calculate these system performance values for the separation of two chromatographic components.

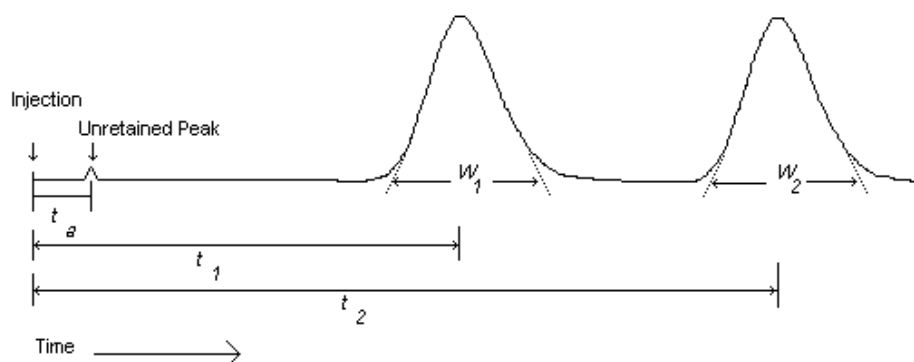

This appendix describes these calculations. Additional calculation methods can be found in the 32 Karat Online Help.

Relative Retention

The Relative Retention of a sample, also known as the Selectivity Factor, is used to determine the relative migration times of different species in your sample and can be a useful way of determining the resolution of your chromatographic method. 32 Karat Software uses the following equation to calculate Relative Retention.

$$\alpha = \frac{t_2 - t_a}{t_1 - t_a}$$

Where:

α = Relative Retention or Selectivity.

t_2 = The retention time measured from the point of injection.

t_1 = The retention time from the point of injection for a reference peak defined in the peak table. If no reference peak is found, this value becomes zero.

t_a = The retention time of an inert component which is not retained by the column. This is taken from the Unretained Peak Time in the Performance Options section of the method.

Capacity Factor

The Capacity Factor, also known as the Partition Ratio, is a very important quantity in column chromatography. It is a measure of the amount of time a given solute spends in the stationary phase relative to the time it spends in the mobile phase. In other words, it is a measurable parameter that can be used to describe the migration rate of your analyte on the column. 32 Karat Software uses the following equation to calculate the Capacity Factor.

$$k' = \frac{t_2}{t_a} - 1$$

Where:

k' = Capacity Factor or Partition Ratio.

t_2 = The retention time measured from the point of injection.

t_a = The retention time of an inert component which is not retained by the column. This is taken from the Unretained Peak Time in the Performance Options section of the method.

Plates per Meter

An important characteristic of your chromatographic system is its efficiency. This is often expressed as the number of theoretical plates per unit of column length, or "Plates per Meter". 32 Karat Software uses the following equation to calculate the number of plates / meter.

$$N = \frac{n}{L}$$

Where:

N = The number of theoretical plates per meter of column length.

n = The number of theoretical plates in the column.

L = The column length in meters. This value is taken from the Performance Options section of the method.

Area / Height Calculations

Area / Height Calculation is one of several different methods used to calculate experimental variables such as column efficiency, capacity, resolution, peak asymmetry, theoretical plates and reproducibility. These calculations are generally set up as part of the 32 Karat System Suitability Options. They allow you to track your column's performance. 32 Karat Software uses the following equations to calculate these values:

Theoretical Plates

$$N = 16 \left(\frac{t_R}{W} \right)^2$$

Where:

N = The number of theoretical plates in the column.

t_R = The retention time of the component.

W = The width of the base of the component peak as measured using the tangent method.

Additionally:

$$W = 4 \otimes \sigma$$

$$\sigma = \frac{1}{\sqrt{2\pi}} \otimes \left(\frac{A}{H} \right) = 0.399 \left(\frac{A}{H} \right)$$

Where:

A = The peak area.

H = The peak height.

Peak Asymmetry (Tailing Factor)

$$T = \frac{W_{0.05}}{2f}$$

Where:

T = The peak asymmetry (tailing factor)

$W_{0.05}$ = The distance from the leading edge to the tailing edge of the peak, measured at a point 5% of the peak height from the baseline.

f = The distance from the peak maximum to the leading edge of the peak at the position of 5% peak height.

Resolution

$$R = \frac{2(t_2 - t_1)}{W_2 + W_1}$$

Where:

R = The resolution between the peak of interest (peak 2) and the peak preceding it.

t₂ = The retention time of peak 2 as measured from the point of injection.

t₁ = The retention time of peak 1 as measured from the point of injection.

W₂ = The width of the base of peak 2.

W₁ = The width of the base of peak 1.

Appendix 3

Understanding PDA Data

PDA data consists of multiple components. These are:

Channel data: each channel is equivalent to a UV trace. Up to three channels can be collected simultaneously.

3D spectral data: the three axes of this data set are time, wavelength, and absorbance.

Multi-Chromatogram data: similar to channel data, this is a trace of absorbance versus time extracted from the 3D spectral data. There are no limits to the number of data sets that can be created.

Channel data and multi-chromatogram data are processed in the same manner as UV data; all the procedures described in this manual apply.

The remainder of this appendix will describe some of the features of PDA data. If you wish to re-create these displays on your computer screen, you will need to open an instrument configured for a PDA detector (offline mode is satisfactory). From a copy of the Data Samples directory, open the data file `PDA Data Sample.dat` and the method `PDA.met`. In the figures in this manual, the background color of the windows have been changed from the default color scheme to facilitate printing.

The multiple components of the PDA data set are available by choosing **View | PDA View** from the menu bar.

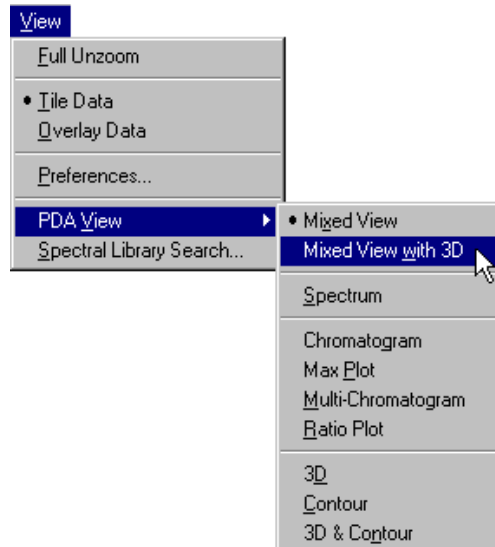

Each item in the menu represents a different way of presenting the data on the screen. Only one of these selections may be made at one time.

Mixed View w/ 3D option

This option is shown below. This image illustrates several of the other options as well.

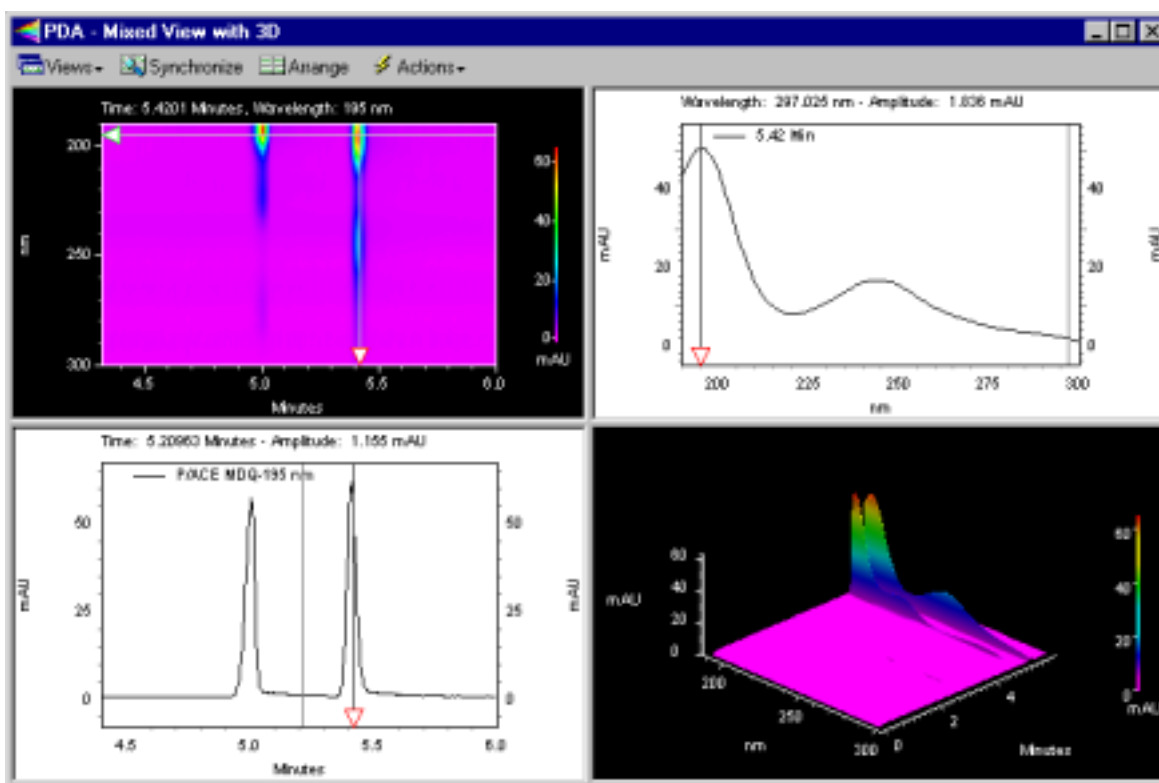

This window shows four different views of the same data set. The sample is the same mixture of Alpha and Beta that has been used throughout this manual. This window is divided into four panes. By clicking and dragging the bars that separate the panes, the relative areas assigned to each pane can be changed. The views available here are:

	Left	Right
Upper	Contour Plot	Spectrum
Lower	Chromatogram	3D Plot

Contour plot

The Contour plot is an overhead view of a three dimensional data set. The X and Y axes are Time and Wavelength, respectively. Absorbance at any given wavelength and at any given time is indicated by color or by a shade of gray. This plot can be “zoomed” by using the mouse to “rubber box” the desired area. Right click and select **Full Unzoom** to restore the view.

Spectrum

The spectrum detected at a specified point in time. This is selected by moving the horizontal slider in the Contour or Chromatogram plots to the desired time point. It represents a slice through the 3D data. This plot can be “zoomed” by using the mouse to “rubber box” the desired area. Right click and select **Full Unzoom** to restore the view.

Chromatogram

The chromatogram at a specified wavelength. This is selected by moving the vertical slider in the Contour plot or the horizontal slider in the Spectrum view to the desired wavelength. It represents a slice through the 3D data in a direction that is perpendicular to the Spectrum view. This plot can be “zoomed” by using the mouse to “rubber box” the desired area. Right click and select **Full Unzoom** to restore the view.

3D Plot

A three-dimensional representation of the data. The presentation of this window is not tied to the Contour view. To adjust the display, right click on the 3D plot and select properties to open the 3D Data Graph Properties window:

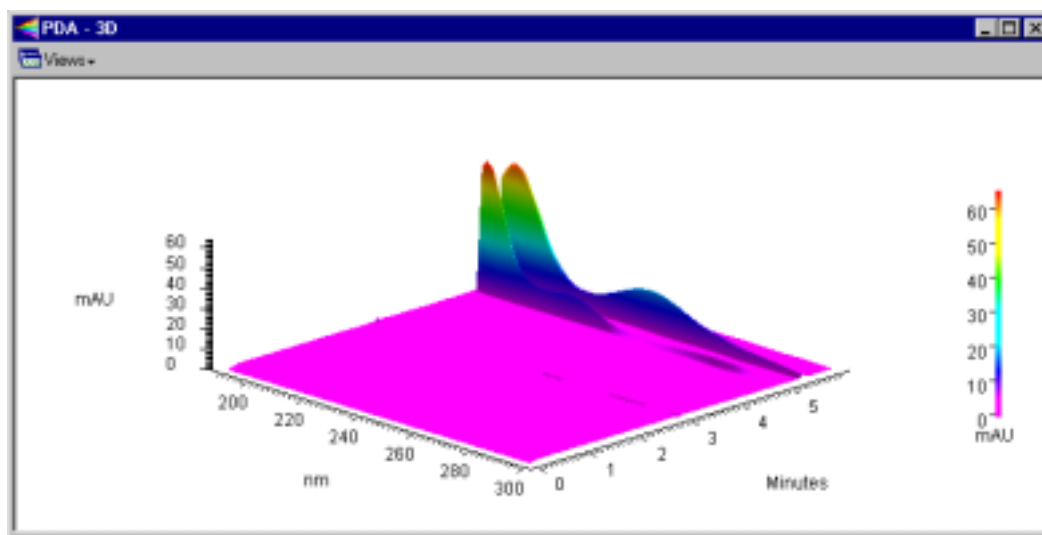

The plot can be displayed as a one-color surface or color can be used to specify absorbance ranges. Colors are user selectable. The image can be rotated around the X and Y axes by selecting the command from the right click menu and manipulating the 3D plot with your mouse or by typing in Elevation and Rotation parameters within the 3D Data Graph Properties window. Zooming is accomplished by setting limits of time, wavelength, and absorbance. The Apply button causes the changes to be made to the 3D plot without closing the properties window. This allows you to test changes without having to close and re-open the dialog.

Mixed View is the same as the Mixed View with 3D shown above, except that the 3D plot is not displayed. This option is handy for speeding up the display of very large data files.

3D and Contour Plot shows only these two plots in a two-pane window

The individual **3D**, **Contour**, **Chromatogram**, and **Spectrum** plots display the individual pane as a full window. The limits of the Chromatogram and Spectrum plots are those set on the Contour window, even if the Contour window is not being displayed. The remaining choices in the PDA View menu are not related to these four items.

The **Max Plot** view is a chromatogram that does not represent a particular wavelength. It is built by taking the maximum absorbance across the wavelength scan range at each point in time. This plot is useful for finding peaks that might otherwise go undetected. This data may be analyzed and the results reported.

The **Multi-Chromatogram** view is only available if multi-chromatograms are defined in the Instrument Setup component of the method. Like the Max Plot, these traces are synthesized from the 3D data set. To set up these channels, open the PDA Options window from the Method menu and select the Multi-Chromatogram tab. Three items must be specified for each channel. The channel can be checked On or Off. Channels which are Off will not be displayed and cannot be analyzed. Wavelength refers to the central wavelength of the data to be incorporated into the multi-chromatogram channel. Bandwidth specifies how many adjacent wavelength bands will be combined to form the new data set. These bands are weighted, with bands more distant from the central wavelength contributing less to the final result than do bands closer to the midpoint. Using too narrow a bandwidth will result in a noisy data file. Using too wide a bandwidth will cause a loss of spectral sensitivity in the data set.

These data may be analyzed and the results reported. If many multi-chromatogram channels have been defined, each will occupy a small area of the display. The frame around each channel can be moved by clicking and dragging with the mouse. Channels can also be temporarily disabled by unchecking them in the Multi-Chromatogram tab of the PDA Options window.

Ratio opens a three pane window. Two windows will display the chromatograms at specified wavelength. The third displays a chromatogram that is the arithmetic ratio of the two ($Abs\#1/Abs\#2$, on a point by point basis). The parameters for this window are set on the X:Y tab of the PDA Options window (available from the Method menu).

When PDA data is selected, the drop-down box in the tool bar will contain a list of the available data channels. Before data can be integrated or analyzed, the desired channel must be selected from this list. Each data channel will have a unique Peaks \ Groups table and Integration Events table, that will be available from the Method menu only when the data channel has been selected.

More information about using PDA data is available in the resources in **Appendix 1**.

Appendix 4

System Administration

The System Administration functions include adding and configuring instruments, which has already been discussed in this manual. It also includes features for defining users and projects. Projects definitions include: defining default folders in which data and methods will be stored; specifying what instrument(s) can be used for a project; defining which users can work on a project, and what privilege level each user will have. These administrative functions are handled through software “wizards,” which are pre-defined step-by-step processes. It is NOT necessary to implement this function in order to use the system.

System Administration is managed from the main 32 Karat Software Screen. From the Tools menu select Options. Click on the Enterprise tab. Clicking on Enable user login and project management will activate the system administration function. The effects will be seen the next time the program is started.

If the System Administration function is activated, a system administrator must be defined immediately. If no system administrator has been defined, there will be no user with the privilege to disable the system administration function, should that be necessary. Depending on the privilege levels assigned to users, not having a system administrator may make some or all software features inaccessible.

When the Enable option is selected, the User list becomes available. Clicking on Add user opens a dialog in which the user's name and password are entered. A password is not required. If a password is used, it must be recorded elsewhere, as there is no feature in the software for generating a list of user passwords.

When all the names are entered (or at least the name of the administrator), user privileges must be assigned. A user with no privileges cannot use the software! New users do not have any privileges until privileges are assigned.

Click *OK* to close the Options dialog. From the Tools menu select System Administration Wizard. The wizard will only be available if System Administration Mode has been selected (checked). A screen will open with three options for: Users, Instruments, and Projects. If there are secondary administrators, they may be given access only to some of these wizards.

The **Users Wizard** allows the assignment of privileges. Follow the wizard step-by-step. Each user can be given access to specific areas of the software and to specific instruments. Selection will depend on the functions of the individual and the degree of security required in the operation of your instrument systems. For example, regulated quality control laboratories generally implement tighter controls over instrument and data access than do laboratories engaged in basic research.

The **Instrument Wizard** allows the administrator to assign users to specific instruments, but not to assign specific privileges on those instruments.

The **Project Wizard** allows the administrator to create projects. A project is a combination of users, instruments, and folders. Projects are most valuable when instrument systems are used by multiple operators or groups who do not need access to one another's methods and data. Creating a project allows the operations on the instrument to be compartmentalized.

The software is shipped with one project, which is called Default. This is a special project, in that it cannot be protected. It should not be used for methods and data that are not intended to be shared.

For more information on System Administration, see the resources in Appendix 1.



Artisan Technology Group is your source for quality new and certified-used/pre-owned equipment

- FAST SHIPPING AND DELIVERY
- TENS OF THOUSANDS OF IN-STOCK ITEMS
- EQUIPMENT DEMOS
- HUNDREDS OF MANUFACTURERS SUPPORTED
- LEASING/MONTHLY RENTALS
- ITAR CERTIFIED SECURE ASSET SOLUTIONS

SERVICE CENTER REPAIRS

Experienced engineers and technicians on staff at our full-service, in-house repair center

*InstraView*SM REMOTE INSPECTION

Remotely inspect equipment before purchasing with our interactive website at www.instraview.com ↗

WE BUY USED EQUIPMENT

Sell your excess, underutilized, and idle used equipment. We also offer credit for buy-backs and trade-ins. www.artisanng.com/WeBuyEquipment ↗

LOOKING FOR MORE INFORMATION?

Visit us on the web at www.artisanng.com ↗ for more information on price quotations, drivers, technical specifications, manuals, and documentation

Contact us: (888) 88-SOURCE | sales@artisanng.com | www.artisanng.com