



**DISHWASHERS
WITH PULL-THROUGH RACK**

**MATIC
M-MA**

**INSTRUCTIONS
MANUAL**



DECLARATION OF CONFORMITY

The following :

LAMBER snc di Affaba F. e C. – Via Italia 6 – 26855 Lodi Vecchio (LO) ITALY

Declare under our responsibility that:

Apparatus:

DISHWASHER WITH PULL THROUGH RACK

Trademark: **LAMBER**

Manufacturer : **LAMBER**

mod. **M115/ASM-130-M150-M150A-M180-M180A**
MATIC 10...20...33prc...33A...39...49...49A...59...59A
MA10-MA20-MA33-MA39-MA49-MA59

for which this declaration refers to the conformity of the following standards:

- *Safety of household and electrical appliances - General requirements EN60335-1(2002) + A1/A11(2004), A12 (2006) + A2 (2006) + A13:2008*
- *Safety of household and electrical appliances - Part 2[^] Particular requirements for commercial electric dishwashing machines EN60335-2-58 (2005) + A1 (2008) + A11 (2010).*
- *Household and similar electrical appliances – Electromagnetic fields – Measurement methods for electromagnetic fields of household appliances and similar apparatus with regard to human exposure EN 62233:(2008)*
- *Limits and methods of measurement of radio disturbance characteristics of electrical motor-operated and thermal appliances for households and similar purposes, electric tools and similar electric apparatus - EN 55014-1–1(2006) + A1 (2009)*
- *Limits for harmonic current emissions (equipment input current ≤ 16 A per phase) - EN 61000-3-2(2006) or $>16A$ and $\leq 75A$ + A2 (2005) EN 61000-3-12(2005)*
- *Limitation of voltage fluctuations and flicker in low-voltage supply systems for equipment with rated current ≤ 16 A. EN 61000-3-3(2008) o $>16A$ e $\leq 75A$ EN 61000-3-11(2000)*
- *Immunity requirements for household appliances, tools and similar apparatus. Product family standard EN 55014-2(1997) + A1(2001) + A2 (2008)*
- *Safety of machinery Basic concepts, general principles for design - Basic terminology, methodology-ISO 12100-1 (2009).*
- *Safety of machinery - Basic concepts, general principles for design - Technical principles-ISO 12100-2 (2009).*

on the basis of what is foreseen by the Directives:

2006/95/CE, 2004/108/CE, 2006/42/CE.
2006/95/EC, 2004/108/EC, 2006/42/EC.

We decline any responsibility for injuries or damage derived from machine misuse, abuse by others or improper machine maintenance or repairs.

(date) li 01/01/2011

Ing. Affaba Roberto

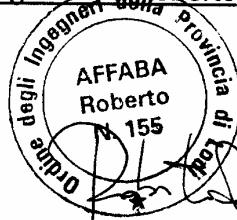

WASTE OF ELECTRICAL AND ELECTRONIC EQUIPMENT DIRECTIVE (WEEE,RAEE in Italy) 2002/96/EC AND SUBSEQUENT 2003/108/EC

The marking shown below indicates that the product cannot be disposed of as part of normal household waste. Electrical and Electronic Equipment (EEE) can contain materials harmful to health and the environment, and therefore is subject to separate waste collection: it must be disposed of at appropriate waste collection points or returned to the distributor against purchase of new equipment of similar type or having the same functions. The directive mentioned above, to which make reference for further details, provides for punitive actions in case of illegal disposal of such waste.



LAMBER, manufacturer of this equipment, is enrolled in the Italian WEEE Register – the Register of Producers of Electrical and Electronic Equipment- from the 18th /02/2008 with the number **IT0802000000617**.

MODEL DESCRIPTION

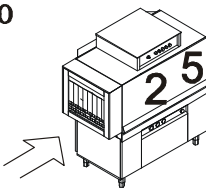
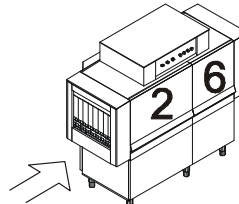
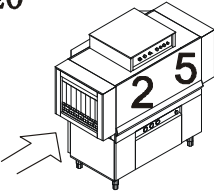
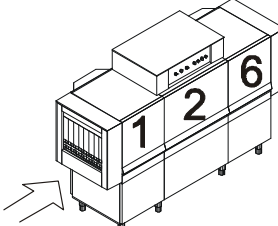
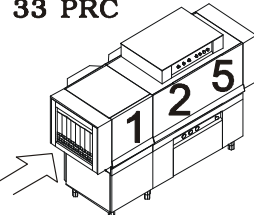
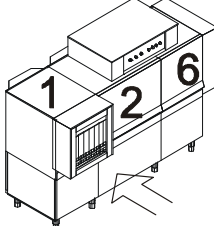
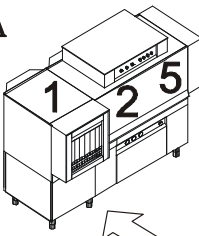
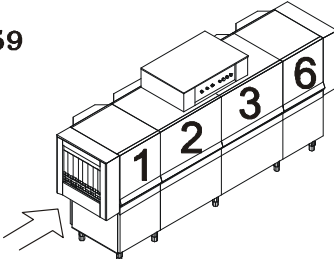
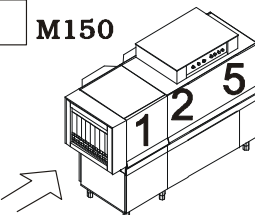
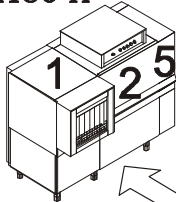
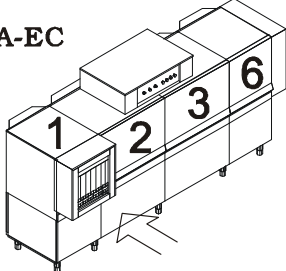
MODEL		MODEL	
<input type="checkbox"/> Matic 10		<input type="checkbox"/> Matic 39 M130	
<input type="checkbox"/> Matic 20		<input type="checkbox"/> Matic 49 M180	
<input type="checkbox"/> Matic 33 PRC		<input type="checkbox"/> Matic 49 A M180 A	
<input type="checkbox"/> Matic 33 A		<input type="checkbox"/> Matic 59	
<input type="checkbox"/> M150		<input type="checkbox"/> M150 A	
		<input type="checkbox"/> Matic 59 A-EC	

SCHEDADESMATIC©dfr

LEGEND

1	PRE-WASHING
2	FIRST WASHING
3	SECOND WASHING
4	THIRD WASHING

5	RINSING
6	PRE-RINSING+RINSING

HEATING

<input type="checkbox"/>	ELECTRIC
<input type="checkbox"/>	STEAM

TECHNICAL DATA AND DESCRIPTION

The table reported at page 3 shows the basic models of conveyor dishwashers and identifies the single washing areas to which additional modules can be added to improve their performance.

ACCESSORIES

COLD PRE-WASHING						
STEAM CONDENSER - CVM	fan		kW			
DRYING – ASM - MVM	fan		kW	Heat element		kW
ADDITIONAL RINSING - RIS						
HEAT RECOVERER – RC-CVM	fan		kW			
AUTOTIMER						
SPLASH SHIELD (PMC-PMA-PMA/R)						
BOOSTER PUMP	Motor		kW			
CVCP HEAT PUMP			kW			

TECHNICAL SPECIFICATIONS

Model:	MATR.		
version	Left-Right		Right-Left

1st speed	baskets/hour	2nd speed	baskets/hour
-----------------------------	---------------------	-----------------------------	---------------------

ELECTRIC POWER	kW
ELECTRICAL INPUT	A
ELECTRIC CABLE	mm²
CIRCUIT BREAKER	A
I_{cc} ELECTRIC INPUT	6 kA
VOLTAGE	

PRE-WASHING	TANK ELEMENTS		kW	ELECTRIC PUMP		kW
FIRST WASHING	TANK ELEMENTS		kW	ELECTRIC PUMP		kW
SECOND WASHING	TANK ELEMENTS		kW	ELECTRIC PUMP		kW
THIRD WASHING	TANK ELEMENTS		kW	ELECTRIC PUMP		kW
PRE-RINSING	TANK ELEMENTS		kW	ELECTRIC PUMP		kW
RINSING	BOILER ELEMENT		kW			
	BOILER ELEMENT		kW			
	GEARED MOTOR		kW			

Contents

General norms	page	06
Introduction and safety norms	page	07
Unpacking and delivery checks	page	09
<u>1 – INSTRUCTIONS FOR THE USER</u>	page	10
<u>First section - For the user – Operation before washing</u>	<u>page</u>	<u>11</u>
Switch-on and use of the dishwashing machine mod. M130-M150-M180-MATIC 10, MATIC 20-33prc MATIC 39-49-59, MA10-20-33-39-49-59	page	13
Symbols used for the controls	page	16
Washing of dishes – During washing operations	page	17
After washing operations	page	19
Helpful suggestions - Achievements	page	21
Safety devices	page	21
Washing flow control system	page	23
Useful hints of stainless steel maintenance	page	24
<u>2 – INSTRUCTIONS FOR THE INSTALLER</u>	page	25
Installation	page	26
<u>Second section - For the installer – Detergents</u>	<u>page</u>	<u>27</u>
Disposal	page	28
Positioning – Electrical connection	page	29
Water connections	page	30
Water draining - Steam feeding – Steam exhaust	page	31
Vapours suction - Testing – Working temperatures	page	32
Torque limiter	page	33
Steam condenser	page	34
Modification of parameter's programming	page	35
Eventual drawbacks –causes - remedies	page	39
Table connection scheme	page	45
Wiring diagram	page	46

INSTRUCTIONS MANUAL DISHWASHING MACHINES

MATIC-M-MA

The automatic-rack conveyor dishwashing machines of the MATIC-M-MA series are designed to wash any kinds of dishes .

The modular system and the various optionals available allow the make-up of dishwashing machines with the most appropriate features in order to meet your production,space saving and energy-saving requirements.



GENERAL NORMS

ENGLISH

Tank You for purchasing our Dishwashing Machine.

Perfect washing-up results as far as hygiene concerns and a correct operation of the dishwashing machine can be assured only in case the instructions reported in the present manual are carefully followed.

We hope the information reported in the present manual will be helpful to You.

They are based on data and our best updated knowledge.

Carefully read the Instructions reported in the manual, recommendations and suggestions included. Carefully read the terms of sale too, the ones limiting warranty included.

INTRODUCTION AND SAFETY NORMS

INTRODUCTION

This equipment is destined only to the use it has been conceived for: tableware washing such as dishes, glasses, cups, cutlery, trays, etc. Using it to wash machine components or objects whose dimensions are superior to the machine working passage is improper and therefore dangerous.

- Equipment in compliance with EEC89/336 directive concerning the suppression of radio interferences and electromagnetic incompatibility.

- In conformity with the EEC directives and the fulfilment laws, our dishwashers are built according to the regulations in force in Italy and abroad.

- The noise of the machine running empty, measured at the working positions (fig. 1) and at 1.6m from the floor, is the following:

	position 1	position 2	position 3
Leq A Level equivalent of sound pressure dB(A)	70	68	70

The level of peak sound pressure Lpc is not declared as it is much inferior to 130dB(C):

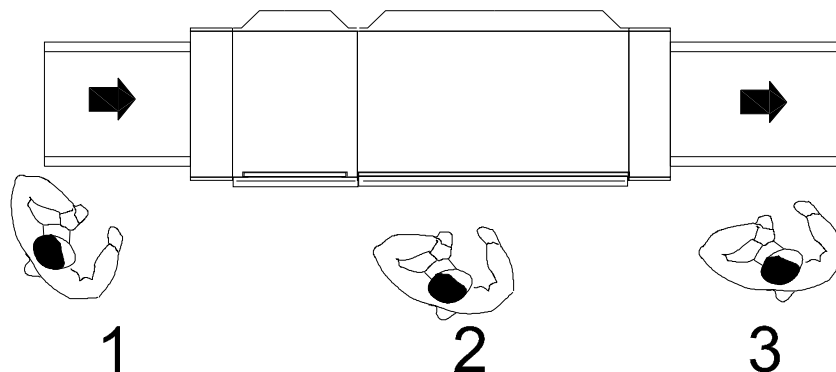

PRELIMINARY OBSERVATION

Carefully read the instructions reported in the present user manual, as it gives important indications about safety of installation, operation and maintenance:

- **carefully keep the present manual for further consultations;**
- the illustrations and drawings showing the machine are intended for general reference only and are not necessarily accurate in every particular;
- the dimensions and characteristics of the machine, given in this Manual, are not to be considered binding and may be changed without prior notice;
- having removed the packing material, check that all the equipment is present. If there is any doubt, do not use it and contact qualified personnel. The packing elements (plastic bags, nails, etc.) should be kept away from children, because they are dangerous.

GENERAL SAFETY REGULATIONS

THIS SAFETY CODE HAS BEEN COMPILED IN YOUR INTEREST. Strict adherence to these rules will reduce the risks of injury both to yourself and to others;

Personnel working with this machine must adhere strictly to all statutory safety regulations as well as the specific rules listed below. Failure to do so may result in personal injury and damage to the machine;

- DO NOT attempt to move, install, set-up or operate this machine until you have read and fully understood this Manual. If doubt persists, ask your supervisor;
- never leave tools, parts or other loose material on or in the machine;
- Before switching the equipment the equipment on, make sure that the model plate data conforms to that of the electrical and water distribution network;
- remember that even with the mains isolator in the "OFF" position, the incoming cables are still live;
- BEFORE starting machine o cycle, after any maintenance or repair work, make sure all protective are correctly installed;
- be vigilant at all times, remember that your safety and that of your fellow workers depend on you;
- when moving or lifting the machine, care must be taken to comply with all the relevant regulations governing such operations;
- installation should be carried out by qualified personnel according to the manufacturer's instructions.
- this equipment should be destined to the use which it has been conceived for. Any other application should be considered improper and consequently dangerous;
- the equipment should only be used by personnel trained for its use;

SPECIAL SAFETY REGULATIONS

- ajustement and repairs must be carried out only by personnel qualified. Repair carried out by unskilled personnel may be dangerous;
- perfect washing-up results as far as hygiene concerns and a correct operation of the washing machine can be assured only in case the instructions reported in the present handbook are carefully followed;
- the machine must be only used by authorized personnel which must comply with sanitary measures;
- do not leave the machine in environment with temperatures inferior to 0°C;
- the machine protection degree is IP55 for Control board and IP32 for machine, **therefore it should not be washed with direct high pressure jets of water;**

UNPACKING AND DELIVERY CHECKS

When the case with the machine has been received, unpack it as follows:

- Remove the upper cover and the wooden case side walls, take care not to damage the machine,
- Remove possible accessories boxes,
- Remove the protecting cellophane,
- Make sure that the machine has not been damaged during transport,
- Make sure that all covers and panels have been correctly fixed and that no loose part is present,
- Visually inspect that all electrical components are integral.

TRANSPORT AND INSTALLATION

- To lift and transport the machine, insert the truck forks under the frame connected to the points indicated by the yellow adhesives applied on the machine front side (see draw below).

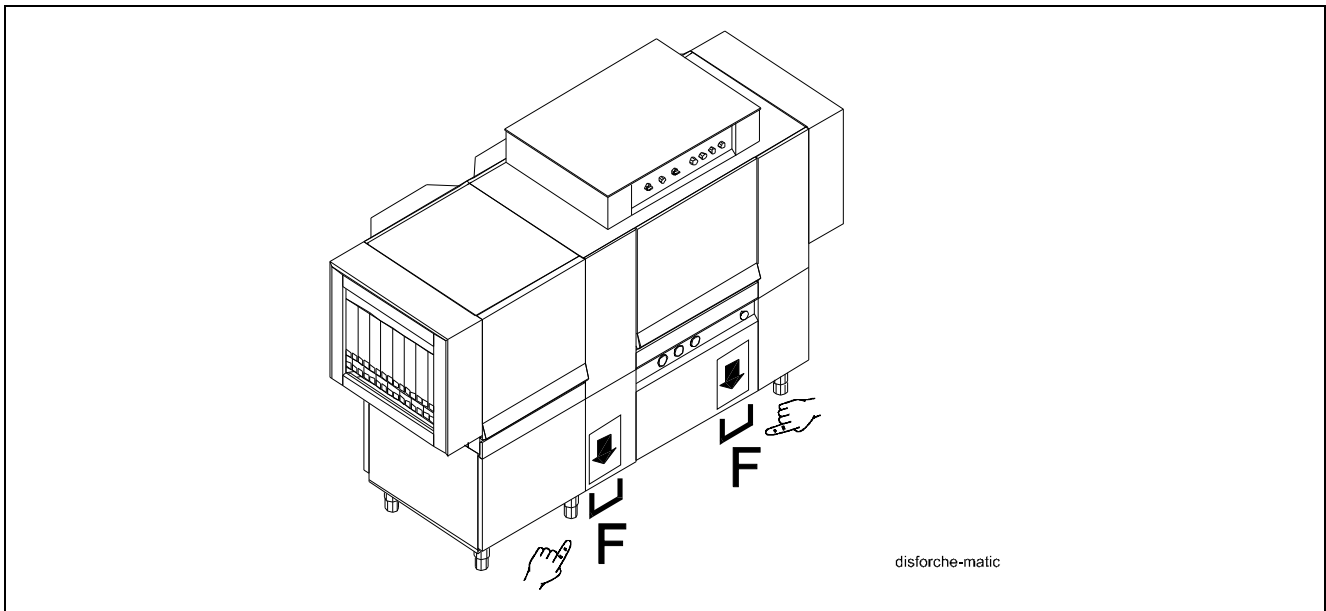

draw "A"*

- Before plugging the machine, make sure that the supply voltage of the domestic wiring system and the water supply from water connection corresponds to the ones reported on the rating plate
- Installation should be carried out by qualified personnel according to the manufacturer's indications

During installation, it is recommended to level the machine in order to ensure a correct operation.

INSTRUCTIONS FOR THE USER

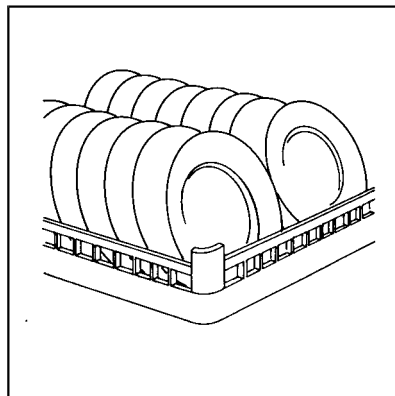

1

First Section - FOR THE USER

OPERATION BEFORE WORKING

BEFORE STARTING THE WORKING OPERATION BE SURE THAT:

- the wall-mounted on/off switch is switched on;
- the water and steam* cocks are open;
- water and steam (*) are present in the system;
- the filters are in their housings
- curtains are correctly positioned;
- the inspection doors are closed;
- the dimensions of the dishes to be washed do not exceed the washing working dimensions;
- Check that the detergent and rinse aid containers are not empty.
- Switch the machine on . Go to the page dealing with the model selected .

(*) for steam machines only

DETERGENTS

In case the machine is not provided with an automatic dispenser, pour the detergent directly into the washing tank and uniformly distribute it on the filters in the doses indicated by the supplier.

N.B.: If you make use of chlorinated sanitizers, **it is always advisable the employment of an automatic dispenser with feeler for the measurement of the detergent concentration**, because brownish spots can form on the surfaces due to chlorine reactions when pouring the detergent directly into the tank.

In any case the product shall be introduced near the pump suction pipe in the tank and at least 15 cm far from the bottom in order to avoid corrosion.

Choice of the suitable cleansing agent is an essential condition if you want to obtain extremely good washing results as concerns hygienic results.

It is then important to consider some points.

First of all only highly alkaline and chlorine-active antifoam products, especially made for industrial dish-washing machines, must be used and they must be produced by well known reliable Firms. We provide a short list just as an indication: Ecolab-Soilax; Henkel; Lever; Diversey; Relativ.

Mean concentration of the powder cleansing agents must be 1,5-2,5 g/lit.

Mean concentration of liquid cleansing agents must be 2-4 g/lit.

In order to avoid scales and corrosions, put cleansing agent above water level on the nearest area of the sucking pump filter, in this way it will immediately dilute and will not deposit on the tank bottom.

DESCALING

When hard water is used you can find, inside the machine and also on objects, calcareous sediments which must be removed both for hygienic and operating reasons by a descaling operation.

Operating process and frequency of this intervention are suggested by your cleansing agent supplier who has suitable products, generally containing phosphoric acid.

In order to avoid damage to the machine do not increase the quantities and once operations end rinse abundantly.

HYGIENE

At least each 30 days it would be useful to do this operation which guarantees the complete hygienic conditions of the machine. We suggest to contact your cleansing agent supplier who will give you quantity and name of the most suitable product you can use and that, generally, is an active chloride powder (100-200 ppm).

In order to avoid damage to the machine do not increase the quantities and once operations end, rinse abundantly.

ELECTRONIC DISHWASHER STARTUP AND USE

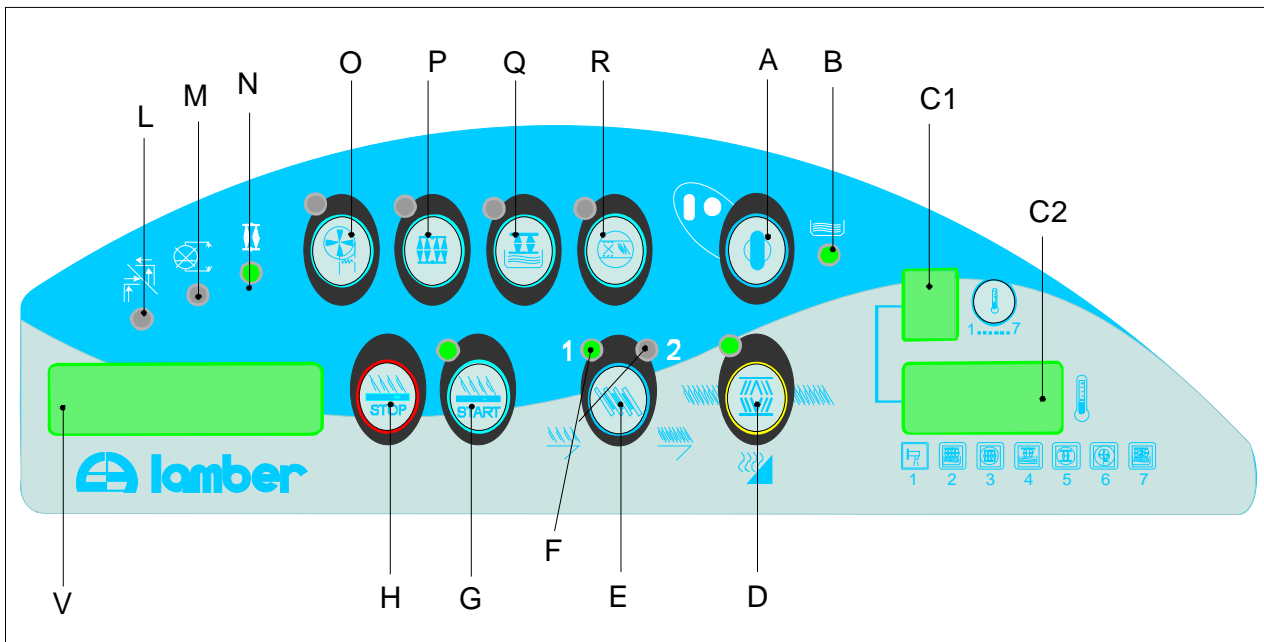

Turn the voltage on by pushing the main button located on the control panel. The thermometer display C1, C2 lights up.

Then follow the instructions:

1) Push the line button "A".

Display information "V" will light up (ON LEVEL) and automatically start the tank loading (lamp "B" is blinking). When lamp "B" turning on indicates that the appropriate level has been reached in the tank and the heater element has been activated (the display visualizes MACHINE READY).

2) Wait until the washing and rinsing temperatures reach respectively 55°C to 60°C and 80°C to 85°C. Check the temperature of thermometers.

The display C1 indicates the number of the probe connected to the temperature indicated on display C2.

pos.1 : water inlet temperature;
 pos.2 : washing temperature;
 pos.3 : rinsing temperature;
 pos.4 : pre-wash temperature;
 pos.5 : pre-rinse temperature;
 pos.6 : drying temperature;
 pos.7 : second washing temperature.
 pos.8 : option.

3) Then push button "D" (led on). The machine is ready to wash the dishes (the information display visualizes now WASHING ENABLED).

4) Select the conveyor speed according to the objects to wash, and push button "E" (led "F" corresponding to the selected speed will light up).

5) Push the START button "G" to start the washing and to move the racks (the display information visualizes now IN CYCLE).

6) Introduce the rack in the tunnel and follow the warning instructions indicated on paragraph "washing instructions" (see pag. 17).

7) The rinsing operation starts automatically at the passage of the dishes (led "N" lights up) (the display visualizes now IN RINSING CYCLE).

If the lamp does not blink there is a problem at the rinsing electrovalve (call a qualified technician).

- 8) Should it be required to stop the washing operations, push button "H" to stop the rack from moving.
- 9) To stop temporarily the rack basket from moving and to interrupt the washing, push the button "D" on OFF position (led off). The other heater elements stay ON (Standby position).
- 10) To turn off the Dishwasher, push the button "A" (led "A" off).

Checking Device:

The display "V" is blinking and visualizes the writing "Door open", it indicates that one of the door was not closed correctly. Close the door again.

The display "V" is blinking and visualizes the writing "Roller conveyor stop activated", take out the basket at roller conveyor stop.

The display "V" is blinking and visualizes the writing "motor Alarm!", it means that there is a problem at the overload cut-out indicator. Call a qualified technician.

During the normal operation of the Dishwasher the **display "V"** will help you to understand which operation the machine is performing.

The display "V" is blinking and visualizes the writing "CALL SERVICE!". The display inform that the maintenance is necessary. The SERVICE function allows to program the maintenance interventions that have to be done on the machine, according to the kind of use. Call a qualified technician.

Optional Devices:

If the machine is equipped with a Drying tunnel it is possible to activate the function of this optional device by pushing the button "O" (led on);

If the machine is equipped with a pre-rinsing device, it is possible to activate the function of this optional by pushing the button "P" (led on);

If the machine is equipped with a heat pump, it is possible to activate the function of this optional by pushing the button "Q" (led on).

WASHING AUTOTIMER (optional)

Thanks to the AUTOTIMER device it is possible to reduce water and power consumption when the machine is not used. To activate this function, push the button "R" (led on).

HEAT PUMP (optional)

The system exploits the heat produced in the cooling cycle, which allows to constantly regenerate energy from the hot air produced in the machine, to preheat the rinsing water.

This device allows to feed the machine with cold water, so as to save a lot of energy (at least 15,5 Kw).

FLOWMETER RINSING (optional)

It checks the water flow is enough for a good final rinsing cycle. The blinking led "M" indicates a possible failure.

PREWASHING CORNER TUNNEL (optional)















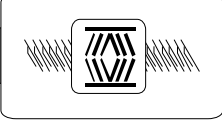
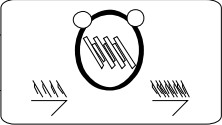

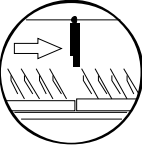
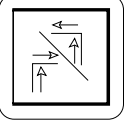
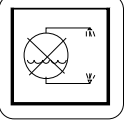

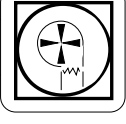
If a PRE-WASH CORNER TUNNEL is installed, the machine indicates when it is possible to insert the basket into the corner tunnel.

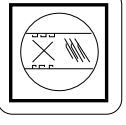
The led "L" .marked with the symbol () lights up when there is a basket inside the corner tunnel.

Once the transport slide has been completed and the tunnel is free, the led "L" goes off: this indicates that it is possible to insert another basket.

"Attention! This unit cannot be connected to any automatic basket loading system. Baskets can be introduced only by hand and by an operator."

SYMBOLS USED FOR THE CONTROLS

- | | |
|--|---|
| <p>A  MAIN ON/OFF SWITCH and MACHINE LOADING</p> <p>B  MACHINE ON LAMP</p> <p>C1  DISPLAY TEMPERATURE NUMBERS</p> <p>C2  TEMPERATURE DISPLAY</p> <p>D  CONTINUOUS WASHING</p> <p>E  SPEED BUTTON</p> <p>G  START PUSHBUTTON</p> <p>H  STOP PUSHBUTTON</p> <p> TENTS POSITION</p> | <p>L  CORNER LOADING ON</p> <p>M  FLOWMETER</p> <p>N  RINSING ON</p> <p>O  DRYING ON</p> <p>P  PRE-RINSING ON</p> <p>Q  HEAT PUMP</p> <p>R  TIMED WASHING, FOR MACHINES WITH AUTOTIMER</p> <p>1  WATER INLET THERMOMETER</p> <p>2  WASH THERMOMETER</p> <p>3  RINSING THERMOMETER</p> <p>4  PRE-WASH THERMOMETER</p> <p>5  PRE-RINSING THERMOMETER</p> <p>6  DRYING THERMOMETER</p> <p>7  SECOND WASHING THERMOMETER</p> <p>8  OPTIONAL</p> |
|--|---|

QUMA-EK-SIMB-GBR

WASHING OF DISHES

- 1) First of all, remove any food residues and any oily masses .
- 2) Knives , forks and spoons should be previously softened; the same applies to dishes, should they be washed a long time after their use .
- 3) Arrange the dishes as shown in the figures (page 18) .
- 4) Push the rack toward the inlet of the machine. The feeding system will make it step up automatically . (N.B. Insert the shelves so that dishes are faced to the inlet and trays are parallel to the machine).
- 5) If the operator is not in a position to remove the shelves from the outlet bracket, they, upon reaching the end thereof, would cause the feeding system and rinsing to stop. In order to restore the operating conditions, it is sufficient to remove that shelf that operates limit switch micro .

DURING WASHING OPERATIONS

- 1) Check that the water temperatures are in accordance with the specified values .
- 2) Monitor the levels of the detergent and the rinse agent liquid in the respective containers .
- 3) Remove the pre-wash filters periodically and remove any residues therefrom; it is suggested to buy another spare filter in order not to have to stop the machine for an extended period of time .
- 4) Avoid dipping your naked hands into the soapy hot water present in the tanks. This can cause burns and skin irritations.

In this case, immediately rinse them with plenty of water.

- 5) When the machine is working, do not open the inspection doors too quickly.
- 6) In case the conveyor belt is stopped by the safety device (limit switch), stop the machine by means of the red emergency mushroom pushbutton located near the operator before removing the obstacle causing the trouble.
- 7) Deactivate the equipment in case of fault or malfunction. For repairs, only address to a technical assistance center authorised by the manufacturer and impose the use of original spare parts.

The non-observance of the above could compromise the safety of the appliance and of the operators.

For possible troubles occurring during the working cycles, see the relevant chapter.

BASKETS



AFTER WASHING OPERATIONS

PRECAUTION AND CLEANING INSTRUCTIONS

- high temperatures can be reached inside the machine (90°C). After power supply has been removed, wait until the machine has reached the room temperature, before working on it;
- never leave tools, parts or other loose material on or in the machine;
- BEFORE starting machine or cycle, after any maintenance or repair work, make sure all protective are correctly installed;

At the end of the working operations:

- 1 – Push the STOP button “H” and push the button "A" to switch off the machine.

Attention! For machines with Drying system it is necessary to *wait 5 minutes* before pushing the button "A" to switch off the machine;
This make Fan able to cool elements.

Tank drain by drain valve

It is necessary to push the button “D” at the end of the working process for 3 seconds:
-The LED will flash and on the information display you will read “TANK DRAIN” (attention! The “A” button has to be on switch-off position).
-After two minutes the drain stops automatically.

2 - Take off the machine by means the disconnecting switch located on the control panel.

3 - **IMPORTANT:** Before carrying-out the cleaning and maintenance operations,

disconnect the equipment from the mains voltage through the wall-mounted on/off switch and close the water and steam* supply cocks;

- 4 - Lift the inspection doors making sure that they are firmly linked to the apposite support.

- 5 – **only for M130-M180:**
Take out the overflow (draw 4 n.6) from pre-rinsing tank.

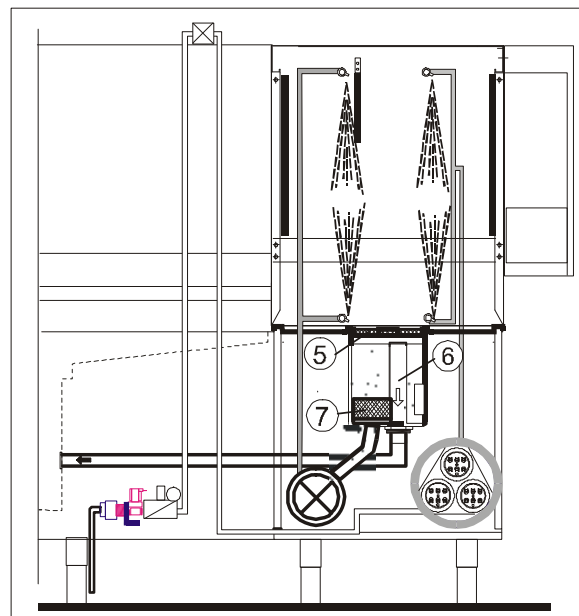

fig.4 – Pre-rinsing zone

- 6 - Wash the inside of the machine with a water jet.
- 7 – When everything is clean and water is completely drained, take out and clean carefully the flat filters the suction pump filters and that of the pre-wash and wash them carefully every day (don't beat them against the floor or others) .
- 8 – Remove and wash the splash-guard curtains.

- 9 - For machines with steam condensation only, remove the steam aspiration filter (fig.5) and clean it.

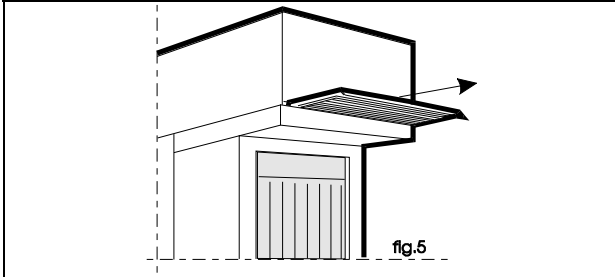

fig.5 – Steam condenser

- 10 - Check that the washing nozzles are not clogged. If necessary, disassemble the nozzles and pay attention to assemble them again in the right position (twice a week) .
- 11 - Remove the rinsing arms by rotating them counter-clockwise and check that the nozzles are not clogged: if otherwise, clean them using a needle (every week).
- 12 - Replace the filters taking care that: Curtains shall have their shortest side turned towards the basket inlet (see the blue signalling marks located on the doors)
- 13 - Clean the outside part of the machine using a wet sponge .Don't use water jets that, beside being dangerous, could also damage the electrical parts.
Don't use detergent, abrasives, steel-wools or steel-brushes.
- 14 – In order to avoid the formation of nasty smells, let the doors open making sure that they are firmly linked to the opposite supports.

Machine prolonged stop

In case the machine is not used for some weeks it is advisable to carry out an accurate cleaning of all components inside to avoid the formation of unpleasant smells.

In case of a very long standstill, it is advisable to oil the stainless steel surfaces with white mineral oil.

* for steam machines only

HELPFUL SUGGESTIONS

MAINTENANCE

IMPORTANT: Before carrying out cleaning and maintenance operations disconnect the machine from the power supply source by means of the wall-mounted switch or by means of the disconnecting switch located on the control panel.

WARNING! - Do not disconnect the switch when the machine is on!

Check and frequently clean the nozzles. The frequency at which such operation shall be carried out will be suggested by the quantity of residues and scales and by the unsatisfying washing results.

To clean the machine outside and inside, never make use of corrosive products such as sodium hypochlorite (bleach) and hydrochloric acid (muriatic acid), acids in general, wire wool and steel brushes.

To avoid compromising the correct operation and to keep the appliance in optimal hygienic conditions, it is advisable to carry out periodical sanifications and scale removing operations.

ACHIEVEMENTS

Any deficiency in the washing process is apparent when dirty residuals are visible. Any halos might be caused by an insufficient rinsing: in this case, check that the rinsing jets are clean and there is a sufficient pressure in the water distribution network (2÷4 bar) ;

In the case that residuals are present, check that:

- the washing jets are clean
- pre-washing temperatur is 40 °C maximum;
- washing temperature is from 55 to 60 °C,

- rinsing temperature is from 80 to 85 °C,
- there is detergent in the right concentration;
- the filters are clean;
- washing water is not dirty;
- the positions of the objects in the rack are correct.

SAFETY DEVICES

The dishwashers are equipped with a number of devices in order to ensure the safety of the operator and of the appliance itself.

LIMIT MICROSWITCH

If dishes reach the end of the unloading area, before the operator has managed to unload the basket, the limit switch stops the drawbar motion and therefore the baskets.

DOOR MICROSWITCHES

Each inspection door is provided with two safety microswitches forming two redundant chains (safety level 2).

If one of the doors is opened accidentally, the pumps, the conveyor belt gearmotor and the rinsing area solenoid valve stop working.

This way all washing operations are stopped preventing dangerous jets of hot water from spurting out.

Operation is restored only when the door are closed again and the start button "H" pressed.

In case of appliances with more complex layouts, more pushbuttons near the operator can be necessary.

EMERGENCY STOP PUSHBUTTON

Dish inlet and outlet side of the machine is equipped with a red mushroom-shaped pushbutton on yellow field, which, if pressed, stops all motors. Once the trouble has been removed, it is possible to restart the machine only after the pushbutton has been rotated and released. Subsequently press the start button "H" again.

More pushbuttons may be necessary near the operators depending upon the appliance washing characteristics.

TORQUE LIMITER

The drawbar forward feeding system is provided with a mechanical friction torque limiter located in the drawbar system.

Each time something interposes between the basket and the machine or the central drawbar is overloaded, the bar motion lowers rapidly to zero.

In this case it is necessary to switch the machine off by means of stop or emergency pushbuttons, remove the obstacle and press the start button again.

To calibrate this kind of device, see the relevant chapter included in the second part of the manual dedicated to the installer.

MOTOR PROTECTION DEVICES

Each motor is protected against short-circuits and current overload by automatic magneto-thermal relays.

Lamp "M" switching on signalizes the intervention of any of these relays.

In this case, the machine should be switched off and qualified personnel should be asked for repair.

ELEMENTS PROTECTION

Each element is protected against short circuit by automatic breakers.

Tank elements are protected against dry running by minimum level pressure switch. Boiler and dryer elements by thermostats with manual reset.

In case of troubles, ask for the intervention of qualified and authorized personnel (see the paragraph dedicated to the user).

RESIDUAL RISKS

Although the appliance is equipped with the above-mentioned safety devices, danger of burns to upper limbs persists.

As already mentioned in the paragraph "DURING WASHING OPERATIONS", avoid dipping your naked hands into soapy hot water of the tanks. This can cause burns and skin irritations.

In this case, immediately rinse them with plenty of water. Anyway consult the product card of the detergent employed.

WASHING FLOW CONTROL SYSTEM

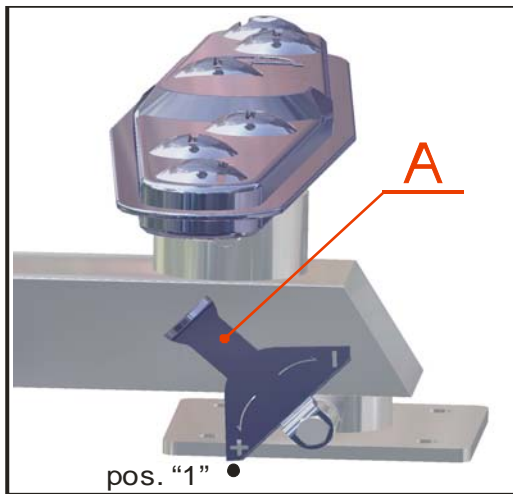

Highest power (position 1)

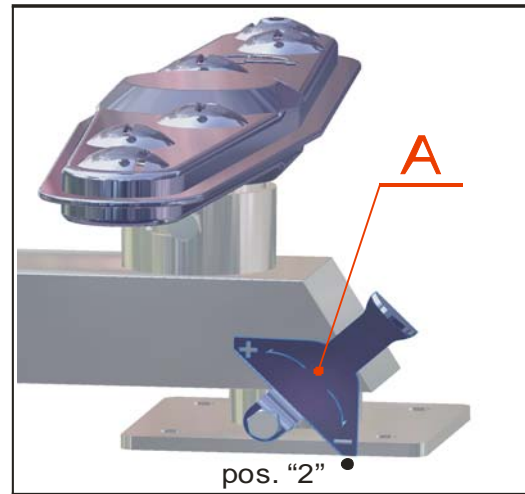

Lowest power (position 2)

The flow control system is a device that allows You to act on the intensity of the washing power.

This can be useful by washing glasses, when it is necessary to reduce the washing jet power.

This device is placed into the pre-washing and washing areas of the rack conveyor dishwashing machines, by the lower washing arms group.

In order to act on the control system You have to rotate the lever "A" by hand anticlockwise to rise the washing jet power and clockwise to reduce it.

If You turn it thoroughly leftwards, You get the highest power (pos.1).

If You turn it thoroughly rightwards, You get the lowest power (pos.2).

USEFUL HINTS OF STAINLESS STEEL MAINTENANCE

Stainless steel is so called because it is not affected by oxidation, this is due to a thin molecular layer of oxide on the surface which protects against further oxidation. There are, however, substances which can modify or destroy this layer, giving rise to corrosion: besides preventing the protective film of oxide from reforming, these substances corrode the stainless steel itself and can cause irreparable damage. It is therefore necessary to prevent this by choosing correct cleaning products and by complying with the following simple recommendations: **never forget that when using these appliances, the first and fundamental rule is to guarantee that the cleaning products are both non-toxic and hygienic.**

Before using any detergent to clean either the stainless steel or the immediate and surrounding floor area, always ask your supplier for the most suitable product which does not cause corrosion on the steel itself; the onset of rust is most commonly caused by the use of unsuitable cleaning materials (strongly acid chlorate based detergents) or on inadequate maintenance.

Our appliances are made of stainless steel AISI 304 (18-10 type) for exterior panelling, upper tops, tanks etc.
Comply with the following instructions when cleaning and servicing parts in stainless steel.

Ordinary daily maintenance

Carefully and frequently clean the surfaces using a damp cloth; use soap and water or normal detergents, **so long as these do not contain abrasives or chlorine based substances** such as sodium hypochlorite (bleach), hydrochloric acid or other such solutions: These products quickly and irreparably corrode stainless steel. When cleaning floors underneath or near the appliances, never use the above mentioned products as vapours or splashes could subject the steel to similar destructive effects.

Only ever rub in the direction of the satining, then thoroughly rinse with clean water and carefully dry.

Rust : water supply pipes, inevitably convey particles of rust dissolved in the water especially in new installation plants or when taps are opened after a period of inactivity. These iron deposits must not be allowed to remain on the stainless steel since they produce rust by contamination.

Use suitable products to remove any rust marks, from companies which produce detergents for industrial use. After application, thoroughly rinse with clean water, neutralizing the action of the product with an alkaline detergent normally used to clean such appliances or with another specific product.

DO NOT USE METAL MATS TO CLEAN THE STAINLESS STEEL

INSTRUCTIONS FOR THE INSTALLER

The following instructions are addressed to a qualified personnel, the only one authorised to carry-out checks and repair, if any.
The Manufacturer declines any responsibility in the case of interventions made by a non qualified personnel.

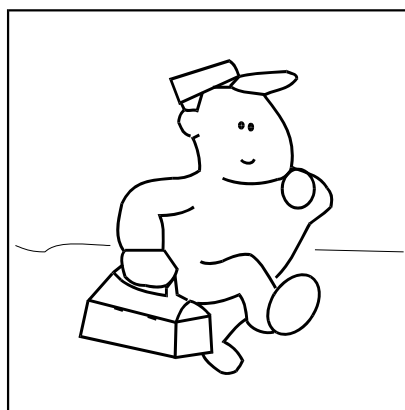

2

Second Section - FOR THE INSTALLER

The following instructions are addressed to qualified personnel who is the only one authorized to carry out the inspections and the necessary repairs.

The machine should be installed in "Normal" environment that is to say, indoors, free of dust, explosion-proof and adequately lit and well aired.

Before installing the machine, it is necessary to arrange the power and water connections.

See the reported wiring diagram (supplied by the manufacturer) of the selected model as far as the dimensions of pipes, cables and wall-mounted switch concerns.

In order to prevent damages caused by the escape of vapours from the equipment make sure that adjacent materials do not deteriorate in their presence.

The Manufacturer cannot assume any responsibility for any damage to persons or property deriving from the non-observance of the above specified norms.

DETERGENTS

The machine should also be equipped with a detergent and brightener dispenser, which shall be supplied by the manufacturer of these products.

N.B.: If you make use of chlorinated sanitizers, **it is always advisable to employ an automatic dispenser provided with feeler for the measurement of the detergent concentration**, because brownish spots can form on the surfaces due to chlorine reactions when pouring the detergent directly into the tank. The feeler for the measurement of concentration must be placed on the front side of the tank through the hole "**A**" preset for such operation (see drawing on page 28).

In any case **the LIQUID DETERGENT** shall be introduced through the preset hole "**B**" on the front side of the washing tank.

Choice of the suitable cleansing agent is an essential condition if you want to obtain extremely good washing results as concerns hygienic results.

It is then important to consider some points.

First of all only highly alkaline and chlorine-active antifoam products, especially made for industrial dish-washing machines, must be used and they must be produced by well known reliable Firms. We provide a short list just as an indication: Ecolab-Soilax; Henkel; Lever; Diversey; Relativ.

The average concentration of liquid detergents must be 2-4g/liter. In any case it is essential that the producer of the detergent rules the dosage properly according to the features of the installation.

As regards the introduction of the **liquid rinse aid product**, use the passage "**C**" , placed near the water inlet group.

This coupling will allow an appropriate introduction of the liquid rinse aid product.
In order to do this use a fitting with non-return valve.

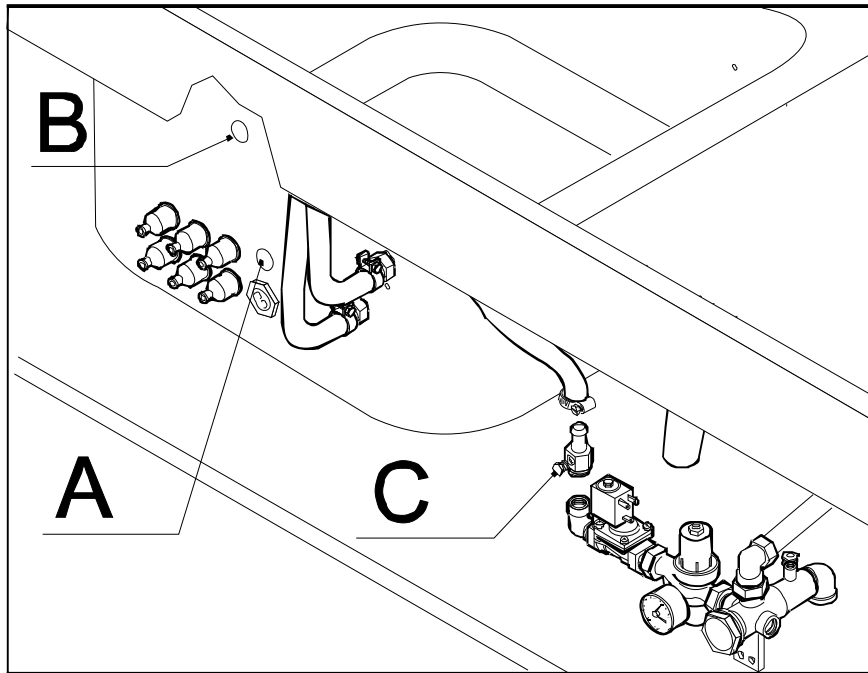

To connect the dispensers there are four **light blue terminals**, marked with apposite labels, which are energized when the pump is working. To avoid damages to the electrical components it is compulsory to use these terminals and avoid movable connections in other points of the plant.

Terminal voltage corresponds to line voltage.

Note: In order to let cables pass, please use the labelled wire clamp behind the electrical control box.

DISPOSAL

At the end of its life, the machine shall be disposed according to the local laws in force by specialized and acknowledged companies in this field. Its components shall be distinguished as follows:

- metallic components: body, plans, frames, filters;
- electric components: motors, remote control switch, microswitches, wiring;
- plastic components: baskets, connections;
- rubber components: hoses, sleeves.

POSITIONING

During installation, carry out a good levelling of the machine in order to let it work properly (doors, basket forward feeding). In order to do so use the adjustable feet.

After removing front panels, position the machine over the connections. Assemble the inlet and outlet shelves for basket loading and unloading. The limit switch FC1 is located on the outlet shelf or on the machine delivery if the shelf is not provided for. The limit switch shall be connected to the outlet shelf. The machine shall also be equipped with detergent and brightener dispenser, which shall be supplied by the manufacturer of these products.

To connect the dispensers there are four **light blue terminals**, marked with apposite labels, which are energized when the pump is working. To avoid damages to the electrical components it is compulsory to use these terminals and avoid movable connections in other points of the plant. Terminal voltage corresponds to line voltage.

ELECTRICAL CONNECTION

Before connecting the machine, check to make sure the voltage outlet of the mains is the same as the voltage specified on the data plate of the machine.

It is also necessary to check that the counter, the mains and the intake are adequately dimensioned to withstand the required maximum load.

A main switch must be installed between the mains and the machine. This safety measure also requires that the minimum distance between the switch contacts is at least 3 mm and the disconnection on all poles according to **EN 60204 (VDE 113)**.

The mains must be wired to be able to handle the current drawn by the machine. The system must also be provided with a proper ground lead in accordance with the existings norms. The electric cable must be of the following type **H07RN-F**.

For a correct selection of the cable rated cross-section refer to the data reported on the product data plate.

The cable cross-section shall not be inferior to the one indicated in the "Technical data and description" reported in the first page of the present manual.

The cable shall be connected to the **isolator IA1** and to the adjacent yellow-green terminal, it shall be made passed and stopped by means of the apposite cable grip.

It is necessary to connect the equipment to an effective ground installation, as specified by the electrical safety regulations in force.

Chack that this basic requirement is complied with and, in case of doubt, ask for a careful check of the installation by a qualified personal.

In addition, the equipment shall be part of an equipotential system, the effectiveness of which should be checked according to the regulations in force.

The connection should be made at the screw marked by the respective label

located on the equipment back side (▽). It is recommended to make the electric line be checked by your own designer.

THE MACHINE SHALL BE CONNECTED WITH AN EFFECTIVE GROUND CLAMP.

The manufacturer declines any responsibility for any damages caused by lack of an effective ground installation.

Emergency pushbuttons:

The machine is also equipped with emergency pushbuttons located by the inlet and outlet areas. Position such pushbuttons in suitable places, according to the characteristics of the washing plant and according to the position of the operators.

WATER CONNECTIONS

Carefully comply with any national or regional regulations in force.

Hot water supply

Arrange a gate valve in an easily accessible place, with a tap having a 3/4" gas thread spout at its end and connect to the water inlet valve (fig.1)

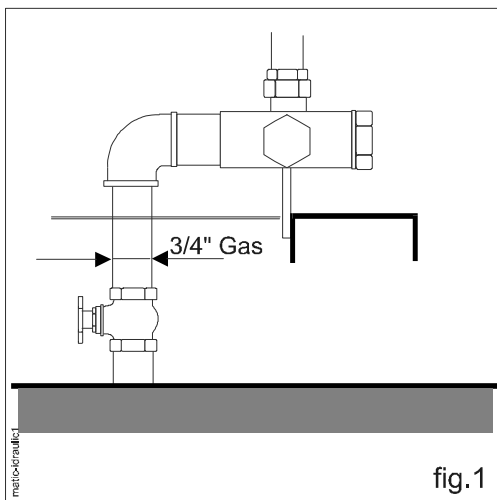

- **temperature** between 55° and 60°C,
- **Dynamic Pressure** 2÷4 bar (200÷400 kPa),
- **Hardness** between 7,2 and 12,5 °f

N.B.: Each machine is equipped with a pressure reducer near the water inlet valves.

In order to obtain an optimum rinse it is necessary to adjust it from 0,6 to 1 bar

according to inlet water pressure and temperature.

(remember that the required dynamic pressure must be 2÷4 bar (200÷400kPa) and that inlet water temperature must be 55÷60°C for standard machines).

If a variation of rinse pressure is required while installing, proceed as follows:

1: make the machine work and check that the rinse is activated;

2: Take away the upper protection plug on the reduction gear and turn the proper adjusting screw anti-clockwise in order to decrease pressure or clockwise in order to increase it or to restore the optimum working conditions (see picture 1A).

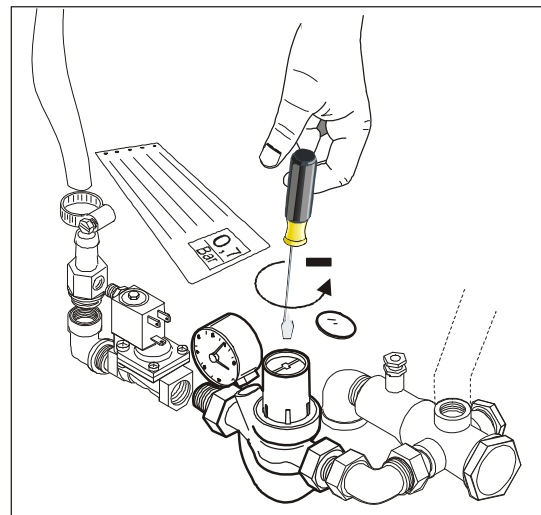

PIC.1A- PRESSURE REDUCER

Cold water supply

This connection is required only for machine with **pre-wash** and any other dishwasher equipped with **steam condenser or regenerator**.

Water shall be supplied at a temperature ranging from 10÷15°C and at a dynamic pressure of 2÷4 bar (200÷400 kPa).

WATER DRAINING

Reachable from the machine front side after opening the front panel (to do this turn the two front screws out);

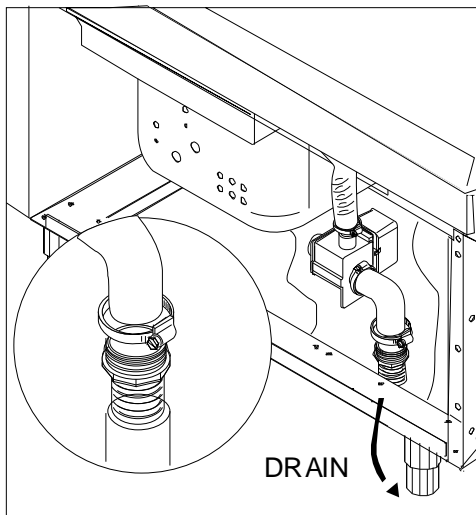

DES-SCARI CO-MATIC-2008

Arrange a discharge at floor level provided with siphon and connect to the floor drain by means of a hose provided with an adequate inclination. Make sure the drain hose is not choked in any way. Make sure the drain hose is resistant to a temperature of 70 °C. Carefully comply with any national or regional regulations in force.

STEAM FEEDING *

As far as steam feeding is concerned, connect to the machine fittings indicated in the installation drawings. In order to make the equipment independent from the general steam distribution network, it is necessary to use gate and gas on/off valves (see draw 2 and 3)..

This type of feeding should be supplied at a pressure ranging from 1 bar (100°C) to 2 bar (121°C).

The steam used should be absolutely saturated and dry.

STEAM EXHAUST *

The condensed steam exhaust shall have an appropriate slope toward the recovery installation or a blow-by pump, in order to guarantee an autonomous scavenging of the condensed steam.

N.B.: for possible maintenance operations, it is advisable to arrange a gate valve parallel with the discharge so that it is possible to deviate condensation towards a runoff pit.

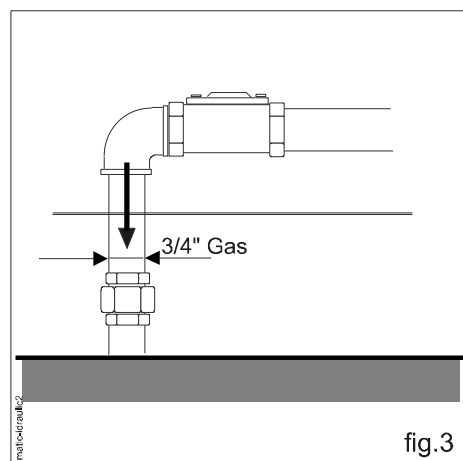
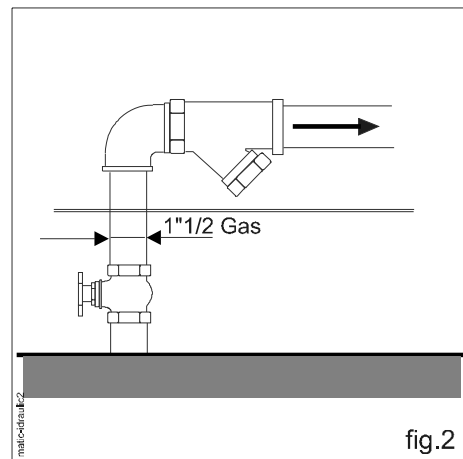

- for steam machines only

VAPOURS SUCTION

For machines equipped with splashguard with collar or heat recovery, carry out the necessary connection as showed in figure 4.

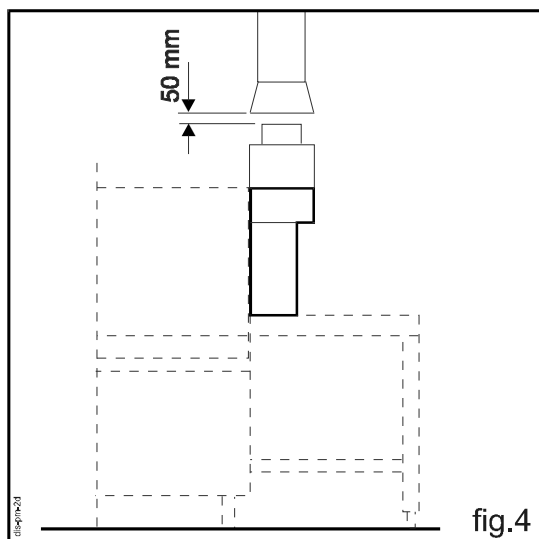

In any case it is necessary to provide a way to extract steam through a hood or a similar system.

TESTING

Before starting machine:

During the testing operations, prior to switching the dishwashing machine on, check that thermostat of the rinsing boiler (0°-90° C) is set to zero and the direction of rotation of the pumps is correct.

Should the pumps rotate in the reverse direction, reverse two wires of the line .

The magnetothermic switch of the boiler IA3 is open (OFF position). Let some empty racks pass through, then check that water jets sprinkle from the rinsing nozzles, then adjust the thermostat of the boiler to 85° C.

WORKING TEMPERATURES

Check that the thermostats are set according to the following working temperatures.

If there is a PRE-WASH unit, check that the maximum thermostat (**CT4**), placed near the pre-wash tank, is ruled on the temperature of 45°C.

ATTENTION! The cooling occurs thanks to the introduction of cold water with working wash pump. This device avoids the excessive growing of the pre-wash temperature. If there is also a thermostat for low temperature (**CT9**) for the heating element in the tank, rule it on the temperature of 35-40°C.

WASHING

The tank thermostat (**CT3**), also placed near the wash tank, will be set according to the following temperature:

Washing water: 55-60°C.

RINSING

The rinsing thermostat (**CT2**) will be set according to the following temperature:

Rinsing water: 80-85°C.

Note: In order to obtain an optimal rinse please check the pression on the pressure reducer manometer. If a new adjustment is required see the specifical paragraph (page 31: water feeding).

PRE-RINSING (only for M39-49-59-M130-M180)

The pre-rinsing thermostat (**CT7**) will be set according to the following temperature:

Pre-rinsing water: 60°C.

DO NOT TAMPER WITH THE THERMOSTAT CALIBRATION

TORQUE LIMITER

The limiter has already been described in the paragraph "SAFETY DEVICES".

It is placed in connection with the drawbar and it is calibrated during testing by the manufacturer.

In case it is necessary to calibrate it again, proceed as follows:

1. Switch the machine off ;
2. Remove the protection panel;
3. Load the whole drawbar with baskets full of dishes to be washed;
4. Loose the axial ring nut with the hexagon ring wrench type "A";
5. Disengage the friction with a hooked key type "B" so that it slips;
6. At this point clockwise turn until the drawbar manages to carry the whole dishes charge;
7. It is considered adequately calibrated when, in second gear, by pressing the start pushbutton, the belt hardly manages to carry the whole load until the end of the delivery shelf.

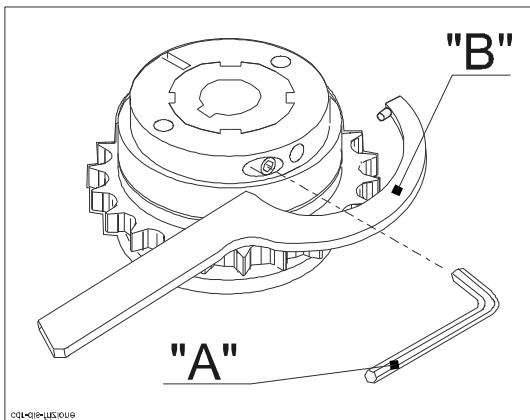

STEAM CONDENSER

As regards the machines provided with “STEAM CONDENSER” device, pay attention to the following:

The adjustment of the device is carried out by means of the regulator valve (COCK “V”) placed inside the machine base plate and marked with its special label.

The Manufacturer should rule this cock while testing the machine.

Never touch this cock without a specific reason.

This valve rules the water flow in the vapour condensing battery.

If the machine needed a more precise adjustment, under regular conditions, adjust the valve until no more vapour comes out of the “vapour condensing” cap.

Generally it is sufficient to slightly open the valve.

ATTENTION! An excessive opening can cause the cooling of the tank.

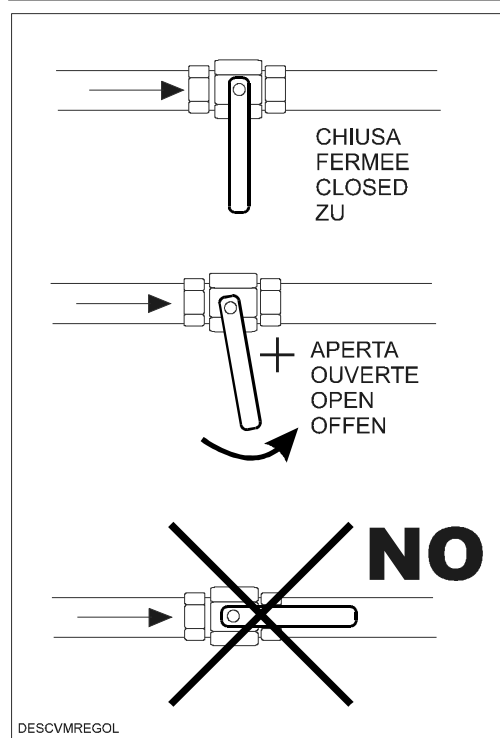
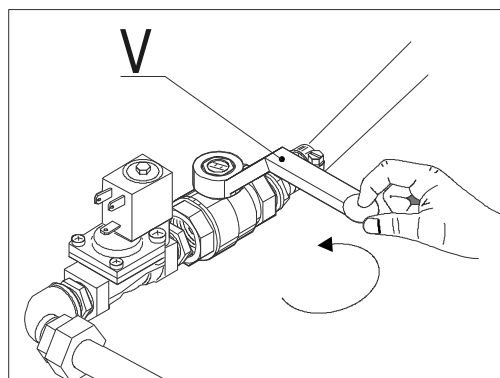

MODIFICATION OF PARAMETERS' PROGRAMMING

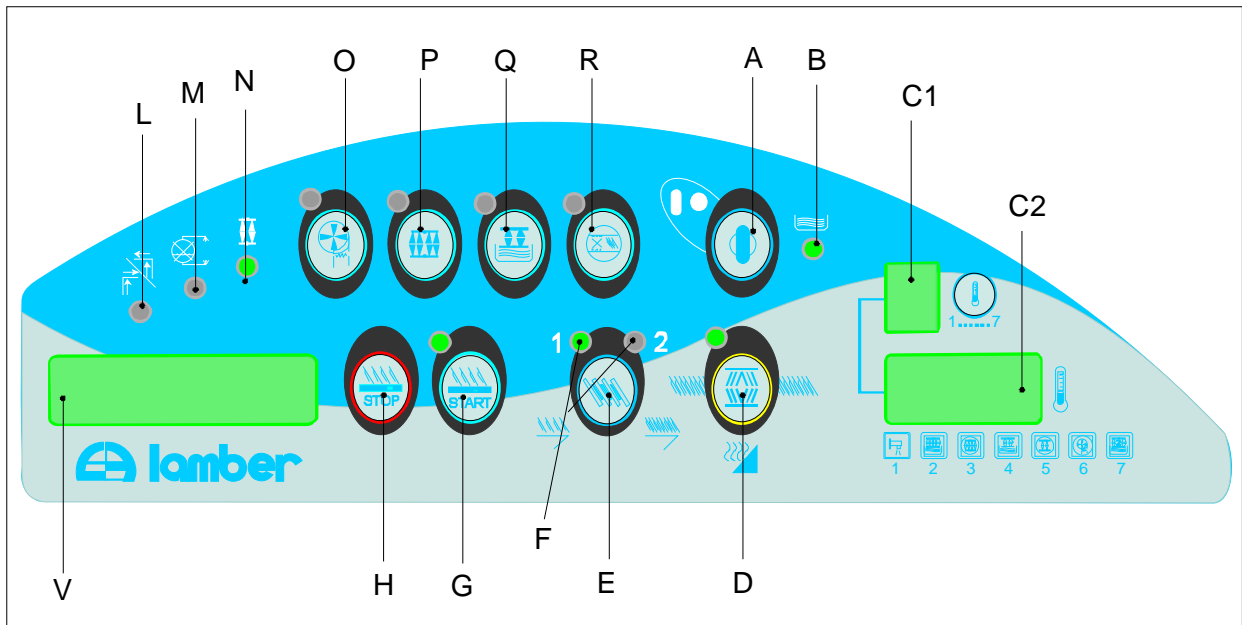

1. Make sure that the wall switch is on;
2. Give power to the machine by the main selector which is placed on the top of the control box: the thermometer display "C1-C2" will turn on, as well as the information display "V", where "OFF" will appear;
3. Push on the "H-G-D" buttons at the same time : on the display "PARAMETERS" will appear ;
4. Push "G"(start) in order to see all the parameters in sequence (see complete list on the following page); (with the "H"(stop) button it is possible to go back to the previous parameter)
5. Modify the parameter acting on the "E" button to reduce and on the "D" button to increase the value of this parameter;
6. To validate the value of the modified parameters it is necessary to push the button "G"(start) until the last "OFF" appears;
7. Push the "A" line button (on the information display you'll see that "ON" will appear);
8. Start the machine and check the right value of the established parameters.

PARAMETERS MATIC-M-MA

Description	Default (Reset)	Modified Parameters
Language	English	
Pre-rinse (Yes-No)	No	
Pre-Rinse Start 1 (0-240s) (first speed)	2s	
Pre-Rinse Start 2 (0-240s) (second speed)	1s	
Pre-Rinse time 1 (0-240s) (first speed)	2s	
Pre-Rinse time 2 (0-240s) (second speed)	1s	
Drying (Yes-No)	Non	
Heat pump (Yes-No)	Non	
Rinse Flowmeter(Yes-No)	Non	
Speed (1-2)	2	
Auto Timer (0-20min)	0min	
Boiler Filling (0-10min)	2min	
Tank Filling Stop (0-240s)	30s	
Tank Filling Alarm (0-60min)	20min	
Rinse Start 1 (0-240s) (first speed)	0s	
Rinse Start 2 (0-240s) (second speed)	0s	
Rinse time 1 (0-240s) (first speed)	1s	
Rinse time 2 (0-240s) (second speed)	1s	
Tanks drain time (0-15min)	0min	
Start after End Switch (0-10s)	3s	
Level (0-240s)	10s	
Stop Washing (0-250s)	0s	
Service (0-2500)	500	
Stop machine (Si-No)	Not	

RESET OF TANK FACTORY PARAMETERS

1- Push buttons **"H"(stop)- "G"(start)- A (I-O)** at the same time.

2- While keeping the above mentioned buttons pushed, give power to the machine by the main selector placed on the top of the control box.

MATIC PARAMETERS' DESCRIPTION

<i>Description</i>	<i>Parameter functioning</i>
Language	Select the language to use: Italian-French-English-German-Spanish.
Pre-rinsing (Yes-No)	Select YES only for machines with pre-rinsing. This function can be activated or not by pressing "P" button.
Pre-rinsing Start 1 (0-240s)	a: (for machines with Pull-through rack) lag at the pre-rinsing pump start from the moment of the basket contact with the rinsing economizer at the first speed . b: (for Belt-towing machines) lag at the pre-rinsing pump start from the moment of the basket or dish passage between the entry's photoelectric cells at the first speed.
Pre-rinsing Start 2 (0-240s)	a: (for machines with Pull-through rack) lag at the pre-rinsing pump start from the moment of the basket contact with the rinsing economizer at the second speed . b: (for Belt-towing machines) lag at the pre-rinsing pump start from the moment of the basket or dish passage between the entry's photoelectric cells at the second speed.
Pre-rinsing duration 1 (0-240s)	a: (for machines with Pull-through rack) lag at the pre-rinsing pump stop from the moment of the exit of the basket contact with the rinsing economizer at the first speed. b: (for Belt-towing machines) lag at the pre-rinsing pump stop from the moment of the dish or basket exit from the entry's photoelectric cells at the first speed.
Pre-rinsing duration 2 (0-240s)	a: (for machines with Pull-through rack) lag at the pre-rinsing pump stop from the moment of the basket contact with the pre-rinsing economizer at the second speed. b: (for Belt-towing machines) lag at the pre-rinsing pump stop from the moment of the dish or basket exit from the entry's photoelectric cells at the second speed.
Drying (Yes-No)	Select YES only for machines with drying tunnel. This function can be activated or excluded by "O" button.
Heat pump (Yes-No)	Select YES only for machines with heat pump. This function can be activated or excluded by "Q" button.
Flow-meter (Yes-No)	Select YES only for machines with flow-meter. It checks the rinsing water quantity. Lamp "M" is lighted up when the rinsing functioning is regular; when the water quantity is inadequate lamp "M" flashes and the display shows "RINSING ALERT".
Speed (1-2)	Select -1- for machines with only one speed and select -2- for machines with two speeds. "E" button allows to select the conveyor's or belt-towing 's speed. The corresponding lamp "F" will be lighted up.
Autotimer (0-20min)	Only for machines with autotimer. Select a time from 1 to 20 minutes to activate it. This function anyway can be activated or excluded by "R" button. It stops the machine after the selected time from when the last basket or dish has passed by the rinsing economizer.
Boiler filling (0-10min)	At every daily start, before filling the tanks, the rinsing system is activated to guarantee the water presence in the boiler. Regulate the time according to the single needs or boiler dimensions.
Tank filling stop (0-60s)	Time during which the tank filling has to continue after having reached the level of the level switch to reach immediately the optimal functioning level.
Tank filling alert (0-60min)	Maximum time for the tank filling, after which the machine stops and

	the display shows this trouble. Alert in case of lack of water or anomaly on the machine drain system.
Rinsing Start 1 (0-240s)	a: (for machines with Pull-through rack) lag at the rinsing start from the moment of the basket contact with the rinsing economizer (at the first speed) . b: (for Belt-towing machines) lag at the rinsing start from the moment of the basket or dish passage between the entry's photoelectric cells (at the first speed).
Rinsing Start 2 (0-240s)	a: (for machines with Pull-through rack) lag at the rinsing start from the moment of the basket contact with the rinsing economizer (at the second speed) . b: (for Belt-towing machines) lag at the rinsing start from the moment of the basket or dish passage between the entry's photoelectric cells (at the second speed).
Rinsing duration 1 (0-240s)	a: (for machines with Pull-through rack) lag at the rinsing stop from the moment of the exit of the basket contact with the rinsing economizer (at the first speed). b: (for Belt-towing machines) lag at the rinsing stop from the moment of the dish or basket exit from the entry's photoelectric cells (at the first speed).
Rinsing duration 2 (0-240s)	a: (for machines with Pull-through rack) lag at the rinsing stop from the moment of the basket contact with the rinsing economizer (at the second speed). b: (for Belt-towing machines) lag at the rinsing stop from the moment of the dish or basket exit from the entry's photoelectric cells (at the second speed).
Tank drain time (0-15min)	Only for machines with automatic drain valve. It fixes the time of the drain cycle.
Start after the conveyor limit stop (0-10s)	Lag time for the restart of the conveyor or of the belt-towing after the stop by the conveyor limit stop to allow to clear the exit table. This lag is activated also at the start of the washing or of the conveyor.
Level (0-240s)	Waiting time for the tank level reset at the washing pumps' start. It can be useful if the machine is equipped with Autotimer and subject to frequent stops and restarts.
Washing stop (0-250s)	Washing stop at limit stop. It allows to stop the washing after some time, from the moment of the baskets stop at the limit stop. The parameter can be set from 0 to 250 seconds.
CALL SERVICE (500-2500)	It allows to fix after how many hours of utilization the dishwasher's maintenance has to be done. The parameter can be regulated from 0 to 2500 hours.
STOP MACHINE (YES-NOT)	This parameter allows to stop the machine after 50 hours of working since the flashing word "CALL SERVICE" appeared on the display.

**A LIST OF DRAWBACKS POSSIBLY OCCURRING WITH THE USE OF THE
DISHWASHING MACHINE, THEIR CAUSES AND POSSIBLE REMEDIES**

1 - Display does not turn on upon switching the machine on

- A - Check that the wall-mounting switch is ON and the respective fuses are not burnt.
- B - Check that fuses FS1-2-3 of transformer TR1 are not burnt .

2 – Pump alarm – Washing pump alarm

A - Check that the overload cutouts of the individual remote switches and replace those disconnected . If such a drawback occurs several times in the same device, it is suggested to increase the current rate through the graduated cursor.

B - Check that the power supply voltage is not subjected to variations in excess of 10% of the nominal value .

C - Check, using an ammeter, that the current drained by the motor does not exceed the rated values .

3 - The tank does not fill, the lamp “B” does not turn on

A - Check that pressure switches CP1-CP2 (those existing) are effective and calibrated.

B - Check that the feeding water intercept is open and water is present in the piping system.

C - Check that the overflows are in their housing.

D - Check that the coil of the solenoid valve EV2 is not disconnected and that tension arrives.

4 - The racks don't step up, feeding rod still

A - Check that nothing is resting on limit switch micro FC1 and this is in good operating conditions .

B - Check that there are no objects got stuck inside the tunnel between the feeding group and the fixed part of the machine.

C - Check that the locking ringnut of the friction clutch in speed reducer M01-M01A1 is not slackened, if otherwise tighten it slowly until the feeding system operates.

D - Check that overload cutouts RM04_RM04A are not triggered, if otherwise restore them.

E - Check that fuses and remote switch coils MT04-MT04A are effective .

F - Check that speed reducer M01-M01A is in good operating conditions .

5 - The racks don't step up, feeding rod moving

A - Check whether one or several pawles are blocked .

B - Check that the central rack of the rack is effective .

6 - The racks don't stop at end of stroke

A - Check that the wheel of micro FC1 projects sufficiently from the bracket and is operated by the shelf.

B - Check that micro FC1 is effective and the respective cable is connected correctly.

7 - The tanks don't stop being filled upon reaching the desired level

A - Check that the trap of the pressure switch has no porosities and the connection pipe is not disconnected .

B - Check that the pressure switch is in good conditions and is calibrated .

C - Check that there is no dirty in the solenoid valve. This drawback can be noted because the machine continues to load water, whilst the main on/off switch is off .

8 - Insufficient washing

A - Check that the detergent is effective, of the type for industrial dishwashing machines, and is proportioned for the right concentration .

B - Check that the detergent container is not empty and operates correctly .

C - Check that the jets of the prewashing, washing and pre-rinsing arms are not clogged. If necessary, clean them.

D - Check that the dishes are placed in the respective racks. Soup plates have to be mandatorily placed in rack type P12-16.

E - Check that the feeding rate is not too high. The first speed shall always be used for knives, forks and spoons that have not been previously softened , for dishes sent to washing after an extended period of time from their use, and for deep or difficult objects.

F - Check that the temperatures in the tanks are the specified ones.

G - One or several pumps don't operate, in this case check that:

- the overload cutout didn't switch the pump in question and, if necessary, restore
- the fuses or the coil of the respective remote switch are not broken
- finally, the pump is not blocked, the motor is effective and rotates in the right direction.

PUMPS ELECTRICAL COMPONENTS

	pre-wash	1st wash	2nd wash	pre rinse
PUMP	M03	M02	M09	M06
CONTACTOR	MT06			
CUTOUT	RM6	RM2	RM9	RM3

H - Shadings or spots present on dishes, specially on glasses, may be caused by minerals present in the water. In such an event, it is suggested to analyze the water used. The contents of calcium and magnesium in the water should not exceed 10°F. The presence of iron should not exceed 0,1 ppm. If these values are exceed, it is suggested to treat the water as appropriate .

I - A preliminary softening is suggested prior to washing knives, forks and spoons

9 - Temperatures insufficient in one or several tanks

- A - Check that the thermostats are effective and calibrated .
- B - Check that the temperature of the feeding water is from 50° to 60° C, as specified .
- C - Check that the thermostats relevant to the tanks are set to the right temperatures and operate correctly .
- D - Check that the fuses and the coil of the remote switch are not broken .
- E - Check that the heater elements are effective .

HEATER ELECTRICAL COMPONENTS

	pre-wash	1st wash	2nd wash	pre rinse
TEMPERATURE	35°-40°C	50°-60°C	50°-60°C	-----
HEATERS	R6	R2	R5	R4
THERMOSTATS	CT4	CT3	CT8	CT7
CONTACTORS	MT06	MT05	MT07	MT10

10 - Rinsing insufficient

An effective rinsing also depends on correct washing operations . Therefore, prior to checking the rinsing system, make sure that washing took place correctly, and specifically look at item X in the respective paragraph. Having ascertained that washing was made correctly, check that :

- A - The dynamic pressure of the feeding water is not less than 2 bars. Should the pressure be insufficient, install rinse buster pump M07 in order to increase pressure .
- B - The nozzles are not clogged by calcareous residuals and they are oriented to the right direction .
- C - Water inlet solenoid valve EV1 operates correctly.
- D - The water input filter is not clogged
- E - Energy-saver microswitch FCE1 is effective .
- F - The curtain of the last tank is in the right position and does not cover the rinsing nozzles when dishes pass there .
- G - The boiler is not scaled to such an extent as to limit the water flow rate.

11 - Rinsing temperature insufficient

The temperature of the rinsing water should range from 80° to 90° C.

Should it be lower, check that :

- A - The thermometer is effective and calibrated .
- B - The temperature of the feeding water ranges from 50° to 60° C specified (excluding machines with drain heat recovery unit) .
- C - The dynamic pressure of the feeding water does not exceed 2 bars. If so, calibrate the pressure reducer incorporated in the machine.
- D - The rinsing nozzles have not been unduly widened or replaced.
- E - The thermostats relevant to boiler CT2 is set to the right temperature and operate correctly.

If the drawback is not due to any of the causes listed hereabove, proceed as follows :

for machines with electric heating

- check that fuses are effective
- check that the coil of remote switch MT03 is not broken
- check all elements of boiler heaters R1
- check the security thermostat CT1 is on

for machines with steam heating

- check that the steam inlet gate is open and it is present with a pressure not less than 0,5 bars,
- check that the filter of the condensated steam drainage is not clogged;
- check that steam solenoid valve EV7 operates correctly,
- check that the input steam filter is not clogged to such an extent as to prevent the normal flow rate,
- check that the condensated steam outlet pipe can freely drain by drop,
- check that the pipe-coil of the boiler is not scaled to such an extent as to limit the heat exchange thereof .

12 - Drying insufficient

An effective drying is strictly related to an effective washing and rinsing. Prior to checking the drying system, check whether washing and rinsing have been made correctly. Then check that :

A - The rinse agent liquid container is not empty and the respective proportioner operates correctly.

B - The air suction holes located on the upper panel are not clogged by foreign bodies.

C - The Overload cutout is not triggered. If so, restore it.

D - Fuses and remote switch coil MT09 are not broken.

E - Motor M05 is not blocked and rotates in the right direction.

F - Using a maximum thermometer, check that the temperature of the hot air jet is at least 80° C. Should it be lower, proceed as follows :

for machines with electrical heating

- check that thermostat CT6 is set to the right position and operates correctly.
- check that fuses and remote switch coil MT07 are effective.
- check that heater element R3 are effective.

for machines with steam heating

- check that the steam inlet gate is open and is present with a pressure not less than 0,5 bars,
- check that the filter of the condensated steam drainage is not clogged;
- check that steam solenoid valve EV7 operates correctly,
- check that the input steam filter is not clogged to such an extent as to prevent the normal flow rate,
- check that the condensated steam outlet pipe can freely drain by drop.

13 - Aspiration and steam condensation insufficient

- A - Check whether foreign bodies obstruct the upper air exhaust hole .
- B - Check that the filter of the condenser battery is not clogged by fat residuals. In such an event, wash it with boiling water and detergent. Rinse thoroughly.
- C - Check that overload cutout is not triggered. If so, restore it.
- D - Check that fuses and remote switch coil MT16 are not broken.
- E - Check that motor M08 is not blocked nor burnt and rotates in the right direction
- F - Check that the cold water feed cock is open and water is present at a pressure of at least 2 bars.
- G - Check that cold water inlet filter D is not clogged to such an extent as to limit the flow rate.

The manufacturer declines any responsibility for any printing errors contained in this booklet. The manufacturer also reserves the right to make any modifications to its products that don't affect the basic characteristics thereof.

ATTENTION !



ENGLISH

FOR A CORRECT WORKING OF THE MACHINE (PUMPS, FANS, ETC.), PLEASE CHECK THAT THE **PULL-THROUGH CRANK** INSIDE THE MACHINE (FIG."A") TURNS ANTICLOCKWISE, OR THAT THE **DRIVE MOTOR** SHAFT UNDER THE WASHING TANK (FIG."B") TURNS IN THE DIRECTION INDICATED BY THE YELLOW ARROW ON THE MOTOR BODY.

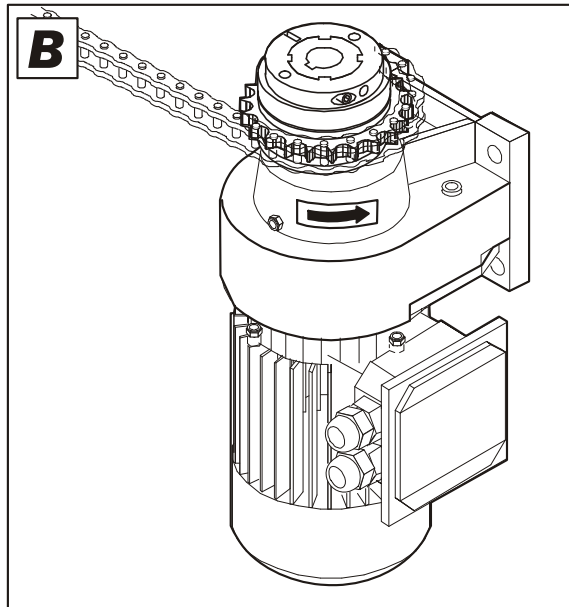
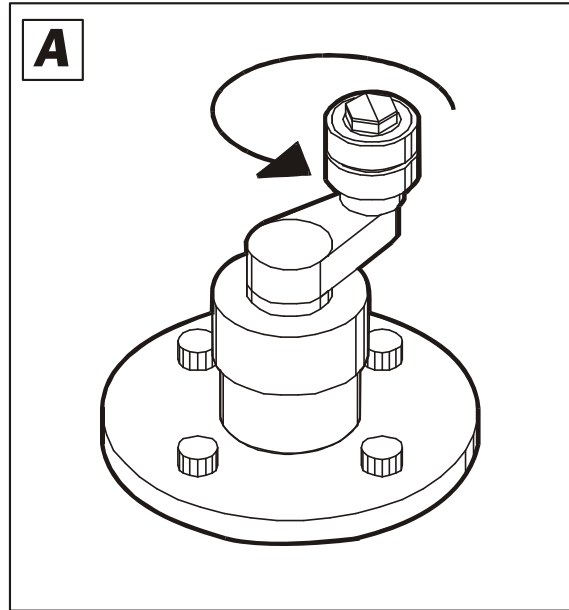

TABLE CONNECTION SCHEME

