

SC-206X Series

User Manual

Optically Isolated and Electromechanical Relay Boards

December 1996 Edition

Part Number 371167A-01

**© Copyright 1989, 1996 National Instruments Corporation.
All Rights Reserved.**

Limited Warranty

The SC-206X Series boards are warranted against defects in materials and workmanship for a period of one year from the date of shipment, as evidenced by receipts or other documentation. National Instruments will, at its option, repair or replace equipment that proves to be defective during the warranty period. This warranty includes parts and labor.

A Return Material Authorization (RMA) number must be obtained from the factory and clearly marked on the outside of the package before any equipment will be accepted for warranty work. National Instruments will pay the shipping costs of returning to the owner parts which are covered by warranty.

National Instruments believes that the information in this manual is accurate. The document has been carefully reviewed for technical accuracy. In the event that technical or typographical errors exist, National Instruments reserves the right to make changes to subsequent editions of this document without prior notice to holders of this edition. The reader should consult National Instruments if errors are suspected. In no event shall National Instruments be liable for any damages arising out of or related to this document or the information contained in it.

EXCEPT AS SPECIFIED HEREIN, NATIONAL INSTRUMENTS MAKES NO WARRANTIES, EXPRESS OR IMPLIED, AND SPECIFICALLY DISCLAIMS ANY WARRANTY OF MERCHANTABILITY OR FITNESS FOR A PARTICULAR PURPOSE. CUSTOMER'S RIGHT TO RECOVER DAMAGES CAUSED BY FAULT OR NEGLIGENCE ON THE PART OF NATIONAL INSTRUMENTS SHALL BE LIMITED TO THE AMOUNT THEREFORE PAID BY THE CUSTOMER. NATIONAL INSTRUMENTS WILL NOT BE LIABLE FOR DAMAGES RESULTING FROM LOSS OF DATA, PROFITS, USE OF PRODUCTS, OR INCIDENTAL OR CONSEQUENTIAL DAMAGES, EVEN IF ADVISED OF THE POSSIBILITY THEREOF. This limitation of the liability of National Instruments will apply regardless of the form of action, whether in contract or tort, including negligence. Any action against National Instruments must be brought within one year after the cause of action accrues. National Instruments shall not be liable for any delay in performance due to causes beyond its reasonable control. The warranty provided herein does not cover damages, defects, malfunctions, or service failures caused by owner's failure to follow the National Instruments installation, operation, or maintenance instructions; owner's modification of the product; owner's abuse, misuse, or negligent acts; and power failure or surges, fire, flood, accident, actions of third parties, or other events outside reasonable control.

Copyright

Under the copyright laws, this publication may not be reproduced or transmitted in any form, electronic or mechanical, including photocopying, recording, storing in an information retrieval system, or translating, in whole or in part, without the prior written consent of National Instruments Corporation.

Trademarks

LabVIEW[®], NI-DAQ[®], and RTSI[®] are trademarks of National Instruments Corporation.

Product and company names listed are trademarks or trade names of their respective companies.

WARNING REGARDING MEDICAL AND CLINICAL USE OF NATIONAL INSTRUMENTS PRODUCTS

National Instruments products are not designed with components and testing intended to ensure a level of reliability suitable for use in treatment and diagnosis of humans. Applications of National Instruments products involving medical or clinical treatment can create a potential for accidental injury caused by product failure, or by errors on the part of the user or application designer. Any use or application of National Instruments products for or involving medical or clinical treatment must be performed by properly trained and qualified medical personnel, and all traditional medical safeguards, equipment, and procedures that are appropriate in the particular situation to prevent serious injury or death should always continue to be used when National Instruments products are being used. National Instruments products are NOT intended to be a substitute for any form of established process, procedure, or equipment used to monitor or safeguard human health and safety in medical or clinical treatment.

Operator's Safety Summary

The general safety information in this summary is for both operating and servicing personnel. Specific warnings are found throughout the manual where they apply but may not appear in this summary.

Terms

In this manual, *Warning* statements identify conditions or practices that could result in personal injury, loss of life, or damage to equipment or other property.

1. Heed all warnings and safety instructions.
2. Never make any signal or cable connection or disconnection when devices are powered on. All connections must be made with devices powered off. Failure to do so can result in a shock hazard.
3. If any voltage potentials can possibly exceed 30 V—particularly potentials across the optocouplers or relays—the SC-206X Series board *must be completely enclosed* in order to protect the operator from shock when devices are powered on. Do *not* leave the SC-206X Series boards uncovered under these circumstances.

Contents

About This Manual	<i>ix</i>
Organization of This Manual	<i>ix</i>
Conventions Used in This Manual.....	<i>x</i>
Related Documentation.....	<i>x</i>
Customer Communication	<i>xi</i>

Chapter 1

Introduction	1-1
What Your Kit Should Contain.....	1-3
Software	1-3
Optional Equipment	1-4
Unpacking	1-4

Chapter 2

SC-2060 Board	2-1
Specifications	2-3
Optically Isolated Digital Input.....	2-3
Power Requirement (from Host Board or External Power Supply).....	2-3
Physical	2-4
Operating Environment.....	2-4
Storage Environment.....	2-4
Mounting and Connection to Data Acquisition Boards	2-4

Chapter 3

SC-2061 Board	3-1
Specifications	3-3
Optically Isolated Digital Output.....	3-3
Power Requirement (from Host Board or External Power Supply).....	3-3
Physical	3-4
Operating Environment.....	3-4
Storage Environment.....	3-4
Mounting and Connection to Data Acquisition Boards	3-4

Chapter 4

SC-2062 Board	4-1
Specifications	4-3
Electromechanical Relay Digital Output	4-3
Power Requirement (from Host Board or External Power Supply).....	4-4
Physical	4-4
Operating Environment.....	4-4
Storage Environment.....	4-4
Mounting and Connection to Data Acquisition Boards	4-4

Chapter 5

Installation and Operation..... 5-1

- Hardware Installation..... 5-1
 - Internal or External Power Selection 5-4
 - SC-206X Series Board Connection..... 5-5
- Operation..... 5-8
- Safety Information 5-9

Appendix A

HCPL-2611-060 Technical Data.....A-1

Appendix B

Motorola Array Technical Data.....B-1

Appendix C

American Zettler Relay Technical DataC-1

Appendix D

Customer Communication.....D-1

Glossary..... Glossary-1

Index.....Index-1

Figures

Figure 1-1.	SC-2060 Board Connected to Host Data Acquisition Board Via an SC-2050 Board	1-2
Figure 1-2.	SC-2060 Boards and SC-2050 Board Mounted in 19 in. Rack Mount with Connection to Host Data Acquisition Board	1-2
Figure 2-1.	SC-2060 Board Parts Locator Diagram	2-1
Figure 2-2.	SC-2060 Power Circuit	2-2
Figure 2-3.	Onboard Equivalent Circuit	2-2
Figure 3-1.	SC-2061 Board Parts Locator Diagram	3-1
Figure 3-2.	SC-2061 Onboard Equivalent Power Circuit.....	3-2
Figure 4-1.	SC-2062 Board Parts Locator Diagram	4-1
Figure 4-2.	SC-2062 5 V Onboard Equivalent Circuit	4-2
Figure 5-1.	Mounting Locations for SC-205X and SC-206X Series Boards	5-2
Figure 5-2.	Attaching a Mountable Board to the Chassis.....	5-2
Figure 5-3.	Double-Height Mounting.....	5-3
Figure 5-4.	Location of the External Power Screw Terminals	5-5
Figure 5-5.	Power Selection Settings for Switch S1.....	5-5
Figure 5-6.	Connecting SC-206X Series Boards to Data Acquisition Boards via the SC-205X Series Cable Adapter Boards	5-6
Figure 5-7.	Pinout for I/O Connector J1	5-7

Tables

Table 1-1.	Data Acquisition Boards for Use with SC-206X Series Boards.....	1-1
Table 2-1.	Data Acquisition Boards for Use with the SC-2060 Board	2-4
Table 3-1.	Data Acquisition Boards for Use with the SC-2061 Board	3-4
Table 4-1.	Data Acquisition Boards for Use with the SC-2062 Board	4-5
Table 5-1.	Amount of Power Data Acquisition Boards Supply	5-4
Table 5-2.	SC-205X Series Connectors Compatible with SC-206X Series.....	5-8

About This Manual

This manual describes the mechanical and electrical aspects of the SC-206X Series boards and contains information about installing and operating the boards. The SC-206X Series consists of three digital signal conditioning boards you can use with National Instruments data acquisition boards—the SC-2060 optically isolated digital input board, the SC-2061 optically isolated digital output board, and the SC-2062 electromechanical relay digital output board. You can use the SC-206X Series boards for digital signal conditioning on the Macintosh NuBus computers with the NB Series and Lab-NB boards, the IBM Personal System/2 (PS/2) Micro Channel computers with the MC Series boards, and IBM PC/XT/AT and compatible computers with the AT Series and Lab-PC+ boards. Each of the SC-206X Series boards is described in detail in this manual.

Organization of This Manual

The *SC-206X Series User Manual* is organized as follows:

- Chapter 1, *Introduction*, describes the SC-206X Series boards; lists the contents of your SC-206X Series kit; describes the optional equipment and software support; and explains how to unpack your SC-206X Series board.
- Chapter 2, *SC-2060 Board*, describes the SC-2060 board in detail including function, compatibility, specifications, mounting, and connection.
- Chapter 3, *SC-2061 Board*, describes the SC-2061 board in detail including function, compatibility, specifications, mounting, and connection.
- Chapter 4, *SC-2062 Board*, describes the SC-2062 board in detail including function, compatibility, specifications, mounting, and connection.
- Chapter 5, *Installation and Operation*, describes the installation and operation of the SC-206X Series boards. Hardware installation, signal connections to the boards, and operation are discussed.
- Appendix A, *HCPL-2611-060 Technical Data*, contains technical data on the Hewlett-Packard Company high-speed TTL compatible optocoupler.
- Appendix B, *Motorola Array Technical Data*, contains technical data on the Motorola Corporation ULN2801 array.
- Appendix C, *American Zettler Relay Technical Data*, contains technical data on American Zettler Corporation relays.
- Appendix D, *Customer Communication*, contains forms you can use to request help from National Instruments or to comment on our products and manuals.
- The *Glossary* contains an alphabetical list and description of terms used in this manual, including abbreviations, acronyms, metric prefixes, mnemonics, and symbols.
- The *Index* contains an alphabetical list and description of terms in this manual, including the page where you can find each one.

Conventions Used in This Manual

The following conventions are used in this manual:

<i>italic</i>	Italic text denotes emphasis or a cross reference.
MIO-16	MIO-16 refers to the AT-MIO-16, AT-MIO-16D, AT-MIO-16F-5, AT-MIO-16X, AT-MIO-64F-5, MC-MIO-16, NB-MIO-16, and NB-MIO-16X boards.
DIO-24	DIO-24 refers to the PC-DIO-24, MC-DIO-24, and NB-DIO-24 boards.
DIO-32F	DIO-32F refers to the AT-DIO-32F, MC-DIO-32F, and NB-DIO-32F boards.
DIO-96	DIO-96 refers to the PC-DIO-96 and NB-DIO-96 boards.
Lab boards	Lab boards refers to the Lab-PC+ and Lab-NB boards.
PS/2	PS/2 refers to IBM Personal System/2 computers.
PC/XT/AT	PC/XT/AT refers to IBM PC/XT, PC AT, and compatible computers.

Abbreviations, acronyms, metric prefixes, mnemonics, symbols, and terms are listed in the *Glossary*.

Related Documentation

The following National Instruments document contains information that may be helpful as you read this manual:

- *SC-205X Series User Manual* (part number 320385-01)

The following National Instruments documents may also be helpful to you depending on the type of system you are using with your SC-206X Series boards.

- Macintosh NuBus users
 - *Lab-NB User Manual* (part number 320174-01)
 - *NB-DIO-24 User Manual* (part number 320094-01)
 - *NB-DIO-32F User Manual* (part number 320095-01)
 - *NB-MIO-16 User Manual* (part number 320295-01)
 - *NB-MIO-16X User Manual* (part number 320157-01)

- IBM PC/XT and PC AT users
 - *AT-DIO-32F User Manual* (part number 320147-01)
 - *AT-MIO-16 User Manual* (part number 320146-01)
 - *AT-MIO-16D User Manual* (part number 320489-01)
 - *AT-MIO-16F-5 User Manual* (part number 320266-01)
 - *AT-MIO-16X User Manual* (part number 320488-01)
 - *AT-MIO-64F-5 User Manual* (part number 320487-01)
 - *Lab-PC+ User Manual* (part number 320502-01)
 - *PC-DIO-24 User Manual* (part number 320288-01)
 - *PC-DIO-96 User Manual* (part number 320289-01)
- IBM PS/2 Micro Channel users
 - *MC-DIO-24 User Manual* (part number 320129-01)
 - *MC-DIO-32F User Manual* (part number 320128-01)
 - *MC-MIO-16 User Manual* (part number 320130-01)

Customer Communication

National Instruments wants to receive your comments on our products and manuals. We are interested in the applications you develop with our products, and we want to help if you have problems with them. To make it easy for you to contact us, this manual contains comment and configuration forms for you to complete. These forms are in Appendix D, *Customer Communication*.

Chapter 1

Introduction

This chapter describes the SC-206X Series boards; lists the contents of your SC-206X Series kit; describes the optional equipment and software support; and explains how to unpack your SC-206X Series board.

The SC-206X Series consists of three digital signal conditioning boards (the SC-2060, SC-2061, and SC-2062) you can use with the National Instruments data acquisition boards. The SC-2060 optically isolated digital input board isolates digital signals received by data acquisition boards from the power system of the host computer. The SC-2061 optically isolated digital output board isolates digital signals sent by data acquisition boards used in systems that are isolated from the power of the host computer. The SC-2062 electromechanical relay digital output board has eight electromechanical relays controlled by digital output signals from the data acquisition boards. You can use the SC-206X Series boards for digital signal conditioning on the Macintosh NuBus computers with the NB Series and Lab-NB boards, the IBM Personal System/2 (PS/2) Micro Channel computers with the MC Series boards, and IBM PC/XT/AT and compatible computers with the AT Series and Lab-PC+ boards.

Table 1-1 lists the data acquisition host boards that you can use with the SC-206X Series boards.

Table 1-1. Data Acquisition Boards for Use with SC-206X Series Boards

AT Series Boards (PC AT)	MC Series Boards (IBM PS/2)	NB Series Boards (Macintosh II)	Lab Series Boards (PC/XT and Macintosh NuBus)
AT-DIO-32F AT-MIO-16 AT-MIO-16D AT-MIO-16F-5 AT-MIO-16X AT-MIO-64F-5 PC-DIO-24 PC-DIO-96	MC-DIO-24 MC-DIO-32F MC-MIO-16	NB-DIO-24 NB-DIO-32F NB-DIO-96 NB-MIO-16 NB-MIO-16X	Lab-LC Lab-NB Lab-PC+

Note: MIO-16 board refers to the AT-MIO-16F-5, AT-MIO-16, AT-MIO-16D, AT-MIO-16X, AT-MIO-64F-5, MC-MIO-16, NB-MIO-16X, and NB-MIO-16 boards. DIO-24 board refers to the PC-DIO-24, MC-DIO-24, and NB-DIO-24 boards. DIO-32F board refers to the AT-DIO-32F, MC-DIO-32F, and NB-DIO-32F boards. Lab board refers to the Lab-PC+ and Lab-NB boards. DIO-96 board refers to the PC-DIO-96 and NB-DIO-96 boards.

Each of the SC-206X Series boards connects to the host data acquisition board (MIO-16, DIO-24, DIO-32F, DIO-96, or Lab) via a corresponding SC-205X Series cable adapter board designed for the data acquisition board you are using. This adapter board connects the specified SC-206X Series board to the desired 8-bit digital port of the host board. Figure 1-1 illustrates an SC-2060 board connection.

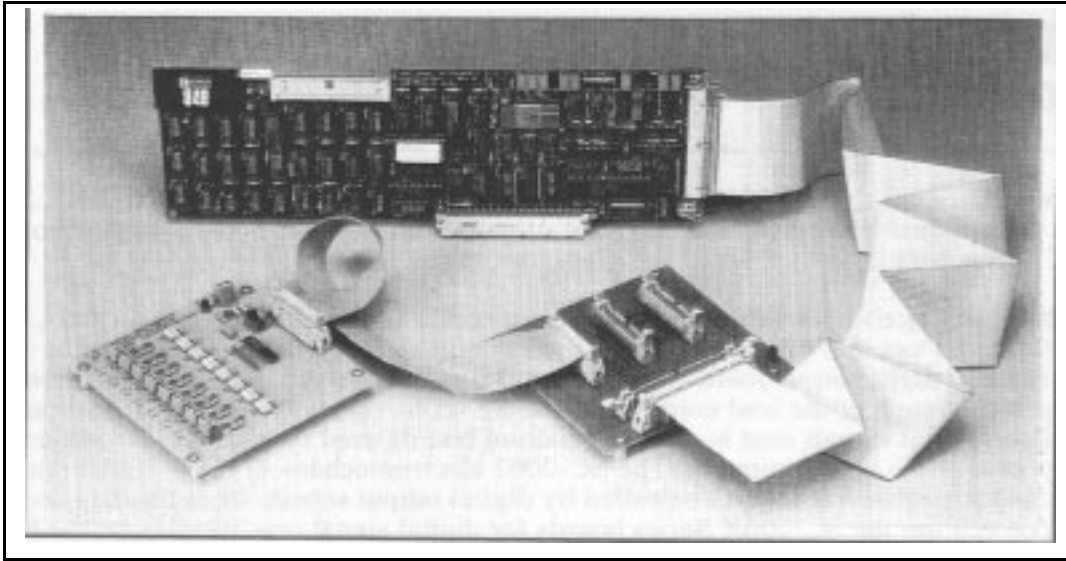

Figure 1-1. SC-2060 Board Connected to Host Data Acquisition Board
Via an SC-2050 Board

The SC-206X Series boards are circuit board assemblies that are external to the host computer. Standoffs are attached to the boards so they can sit on a workbench near the host computer. Alternatively, you can mount the SC-206X Series boards in a 19 in. metal chassis for rack mounting. You can attach a flat acrylic plastic cover or a metal wraparound cover to the chassis. Input signals are attached at screw terminals along one edge of the SC-206X Series boards. Figure 1-2 shows the SC-2060 mounted in a 19 in. rack mount with an SC-2050 mounted alongside it.

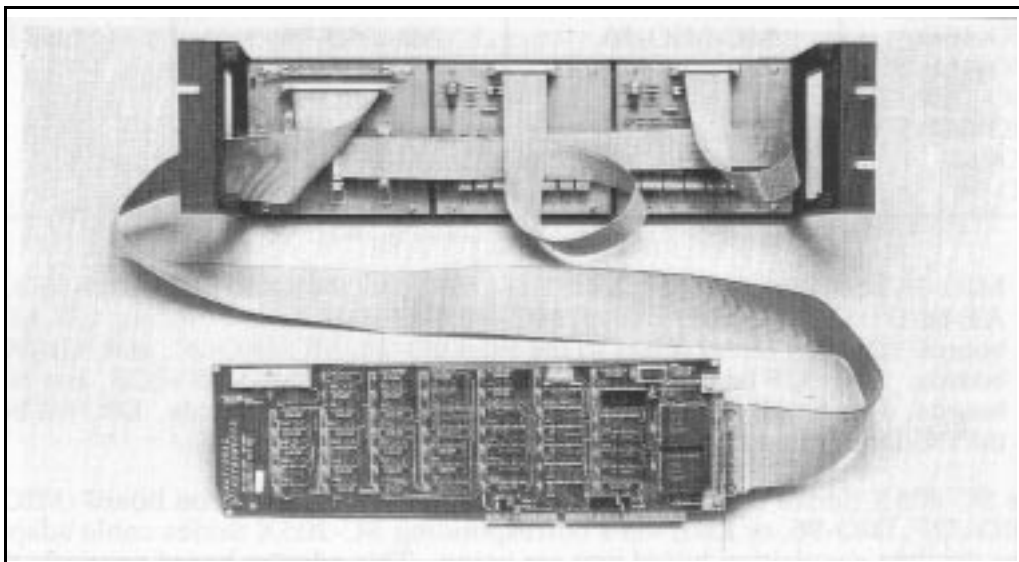

Figure 1-2. SC-2060 Boards and SC-2050 Board Mounted in 19 in. Rack Mount
with Connection to Host Data Acquisition Board

What Your Kit Should Contain

The contents of the SC-206X Series kits are as follows. Notice that there are two versions of each board kit. One version contains a 0.2 m cable, and the other version contains a 0.4 m cable.

Kit Name	Kit Components	Part Number
SC-2060 kit (776336-00) with 0.2 m cable	SC-2060 board <i>SC-206X Series User Manual</i> Type NB7 0.2 m cable	180925-01 320200-01 180924-02
SC-2060 kit (776336-10) with 0.4 m cable	SC-2060 board <i>SC-206X Series User Manual</i> Type NB7 0.4 m cable	180925-01 320200-01 180924-04
SC-2061 kit (776336-01) with 0.2 m cable	SC-2061 board <i>SC-206X Series User Manual</i> Type NB7 0.2 m cable	180930-01 320200-01 180924-02
SC-2061 kit (776336-11) with 0.4 m cable	SC-2061 board <i>SC-206X Series User Manual</i> Type NB7 0.4 m cable	180930-01 320200-01 180924-04
SC-2062 kit (776336-02) with 0.2 m cable	SC-2062 board <i>SC-206X Series User Manual</i> Type NB7 0.2 m cable	180935-01 320200-01 180924-02
SC-2062 kit (776336-12) with 0.4 m cable	SC-2062 board <i>SC-206X Series User Manual</i> Type NB7 0.4 m cable	180935-01 320200-01 180924-04

Contact National Instruments if your kit is missing any of its components or if you received the wrong version.

Software

The SC-206X Series boards require no additional software beyond that you are using for your data acquisition board. The digital I/O lines of the host board control all the SC-206X Series functions.

Optional Equipment

Equipment	Part Number
Rack-mount kit with acrylic plastic cover	
Single-height	180636-01
Double-height	180636-02
Rack-mount kit with metal wraparound cover	
Single-height	181080-01
Double-height	181080-02

Unpacking

Your SC-206X Series board is shipped in an antistatic package to prevent electrostatic damage to the board. Electrostatic discharge can damage several components on the board. To avoid such damage when handling the board, take the following precautions:

- When handling the board, use a ground strap or touch the antistatic package to a metal chassis that is connected to each ground before removing the board from the package.
- Remove the board from the package and inspect the board for loose components or any other sign of damage. Notify National Instruments if the board appears damaged in any way. *Do not* connect a damaged board to your computer.

Chapter 2

SC-2060 Board

This chapter describes the SC-2060 board in detail including function, compatibility, specifications, mounting, and connection.

With the SC-2060 optically isolated digital input board, you can easily connect field digital signals to a computer equipped with a National Instruments data acquisition board. With the appropriate SC-205X Series board, the SC-2060 can have input isolation for the National Instruments data acquisition boards for the Macintosh II, IBM PS/2 Micro Channel, and PC/XT/AT computers.

Each SC-2060 board has screw terminals for eight input channels. Each input screw terminal is optically isolated from the digital I/O pins of the data acquisition board and from the other input terminals up to a working voltage of 300 Vrms. This feature is useful in many situations, especially in industrial and other monitoring environments where common mode voltages are present.

Figure 2-1 shows the parts locator diagram for the SC-2060 board.

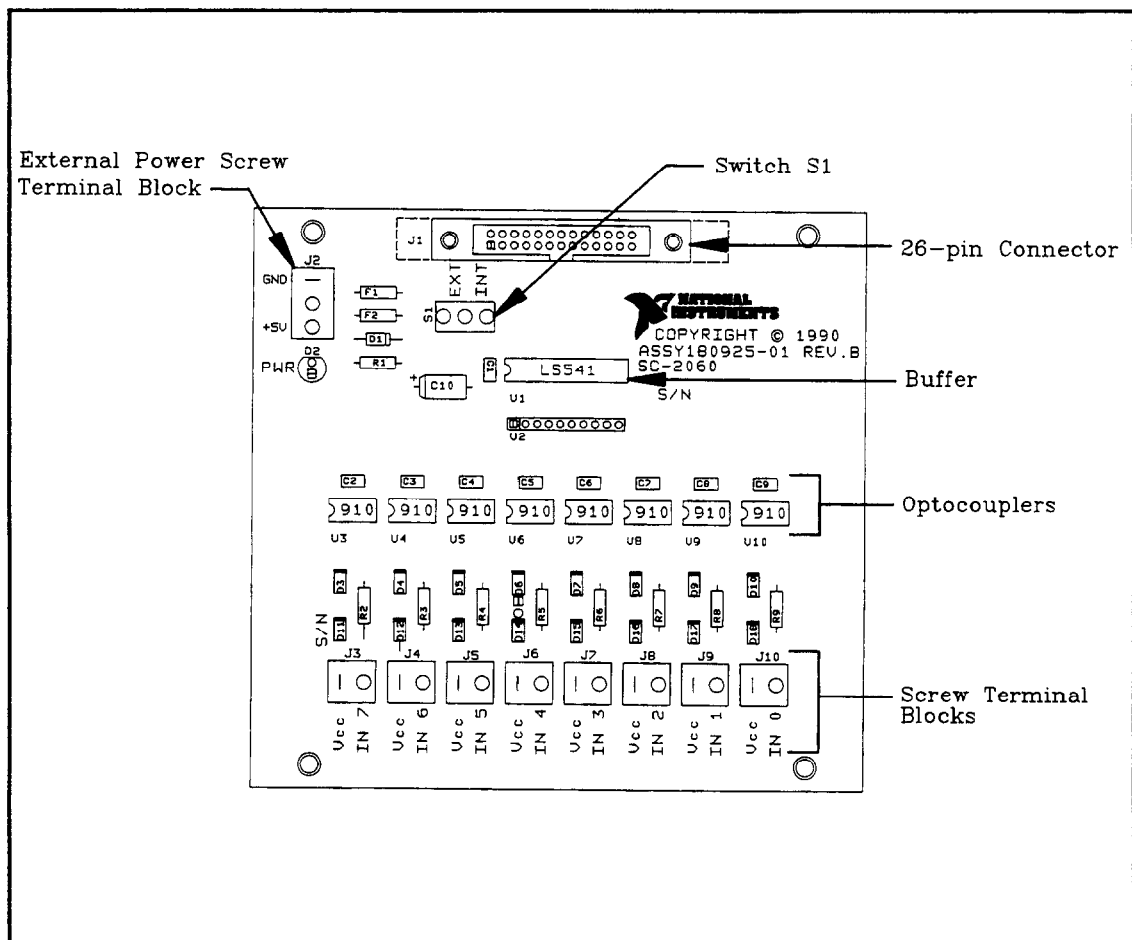

Figure 2-1. SC-2060 Board Parts Locator Diagram

The 26-pin connector (J1) attaches to the appropriate SC-205X Series board via a 26-pin conductor cable. You can connect an external +5 V power supply to the external power screw terminal block (J2) if required. To determine if an external +5 V supply is necessary, refer to *Internal or External Power Selection* in Chapter 5. Switch S1 selects either internal or external power. The buffer improves the logic levels of the outputs from the optocouplers to the host data acquisition board. The optocouplers isolate digital input signals connected to screw terminals IN0 through IN7 (on J3 through J10) from the computer. The Vcc terminal of each pair (J3 through J10) of the contacts connects to the power reference (Vcc) for the digital signal at the corresponding IN_x, where x represents any channel number from zero through seven.

The digital input circuitry is positive logic; that is, a high input signal produces a high input state at the host data acquisition board. The SC-2060 has eight channels of optocoupler input. For each channel, the digital signal must connect to the channel screw terminals along with its voltage reference signal (Vcc). The SC-2060 accepts many types of digital signals, including TTL, CMOS logic, and even voltage references other than +5 V. However, the SC-2060 input circuitry must not carry more than 20 mA (that is, the difference between the voltage reference and the input signal at the terminals must not exceed 8.4 V) to avoid damage to the board. You can add additional resistance in series with the input circuitry to keep the current below 20 mA for voltage differences greater than 8.4 V. Figure 2-2 shows the 5 V power circuit for the SC-2060 board. Figure 2-3 shows an equivalent circuit for the input channels.

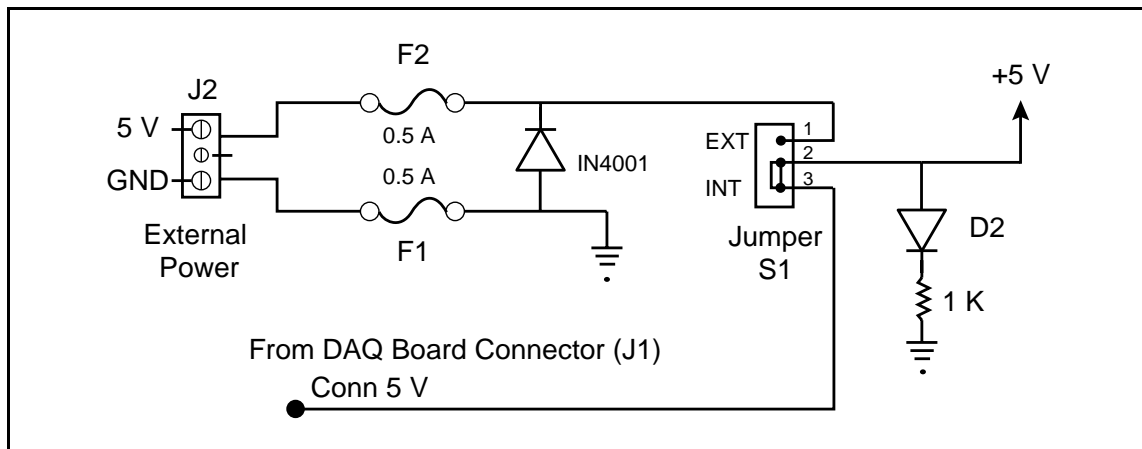

Figure 2-2. SC-2060 Power Circuit

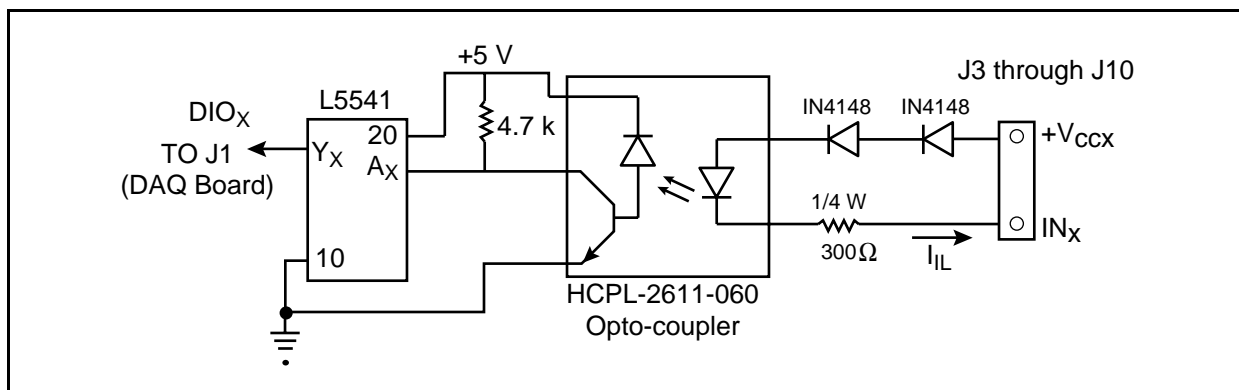

Figure 2-3. Onboard Equivalent Circuit

Warnings: When connecting or disconnecting signal lines to the screw terminals, you must power off the lines. Potential differences between the lines and the SC-2060 ground create a shock hazard while connecting the lines.

Connections, including power signals to ground and vice versa, that exceed any of the maximum input or output signal ratings on the SC-2060 board can result in damage to any or all of the boards connected to the SC-206X Series, to the host computer, and to the SC-2060 board. National Instruments is not liable for any damages resulting from incorrect signal connections.

Specifications

The following sections list the specifications of the SC-2060 digital signal conditioning accessory board. These ratings are typical at 25° C unless otherwise stated. The operating temperature range for this board is 0° to 70° C.

Optically Isolated Digital Input

Number of channels	Eight
Isolation	
Working voltage	300 Vrms (minimum) channel-to-channel or channel-to-ground
Note: This product complies with IEC-1010 for Voltage Installation Category II Pollution Degree 2.	
Common-mode rejection	
Typical	500 V/μs
Minimum	100 V/μs
Data rate	Up to maximum speed of host board (500 kHz)
Propagation delay	$t_{PLH} = 75$ ns (typical) with $I_{IL} = 7$ mA $t_{PHL} = 45$ ns (typical) with $I_{IL} = 7$ mA
Input	
Compatibility	Most TTL and CMOS logic
Input impedance	300 Ω ± 10%, 0.25 W (maximum)
Maximum current	$I_{IL} = 20$ mA (maximum)
Field connections	Two screw terminals per channel

Power Requirement (from Host Board or External Power Supply)

Power consumption (at +5 VDC)

Typical

71 mA \pm 5% with all inputs low

111 mA \pm 5% with all inputs high

Maximum

210 mA

Note: The power specifications pertain to the power supply of the host computer when using internal power or to the external supply connected at screw terminal J2 when using external power.

Physical

Board dimensions (including standoffs)

5.2 by 4.9 by 1.8 in.

I/O connectors

18 screw terminals

One 26-pin male ribbon-cable connector

Operating Environment

Temperature

0° to 70° C

Relative humidity

5% to 90% noncondensing

Storage Environment

Temperature

-55° to 125° C

Relative humidity

5% to 90% noncondensing

Mounting and Connection to Data Acquisition Boards

The SC-2060 has metal standoffs so the board can sit on a workbench near the host computer. You can use an optional rack-mount chassis, which can be fitted with a flat acrylic plastic cover. The SC-2060 grounds to its metal standoffs, and thus to the rack, when it is mounted in the chassis.

Warning: The SC-2060 *must be completely enclosed* if any onboard voltages or voltage differences across the optoisolators can exceed 30 V.

The SC-2060 connects to the data acquisition boards listed in Table 2-1 via the appropriate SC-205X Series cable adapter board.

Table 2-1. Data Acquisition Boards for Use with the SC-2060 Board

Host Data Acquisition Boards	SC-205X Series Boards				
	SC-2050	SC-2051	SC-2052	SC-2053	SC-2054
	AT-MIO-16 AT-MIO-16D AT-MIO-16F-5 AT-MIO-16X AT-MIO-64F-5 MC-MIO-16 NB-MIO-16 NB-MIO-16X	AT-MIO-16D MC-DIO-24 NB-DIO-24 PC-DIO-24	AT-DIO-32F MC-DIO-32F NB-DIO-32F	Lab-LC Lab-NB Lab-PC+	PC-DIO-96

A 26-pin ribbon cable connector connects the SC-2060 board to a digital I/O connector on an SC-205X Series cable adapter board. The SC-205X Series board connects to the data acquisition board with a 50-conductor or 100-conductor ribbon cable. You can connect the SC-2060 to any digital I/O port on any SC-205X Series board. The digital I/O port that is connected to the SC-2060 must be configured and operated on the data acquisition board as input only. For more information on mounting and connection, see Chapter 5, *Installation and Operation*.

Chapter 3

SC-2061 Board

This chapter describes the SC-2061 board in detail including function, compatibility, specifications, mounting, and connection.

With the SC-2061 optically isolated digital output board, you can easily control field digital signals from a computer equipped with a National Instruments data acquisition board. With the appropriate SC-205X Series board, the SC-2061 can have input isolation for the National Instruments data acquisition boards for the Macintosh II, IBM PS/2 Micro Channel, and PC/XT/AT computers.

The SC-2061 board has eight output channels at its screw terminals that are optically isolated from the computer up to a working voltage of 300 Vrms. You can use these boards in many situations, especially in industrial and other control environments where common mode voltages are present. The SC-2061 accommodates output signals that switch at rates up to 500 kHz.

Figure 3-1 shows the parts locator diagram for the SC-2061 board.

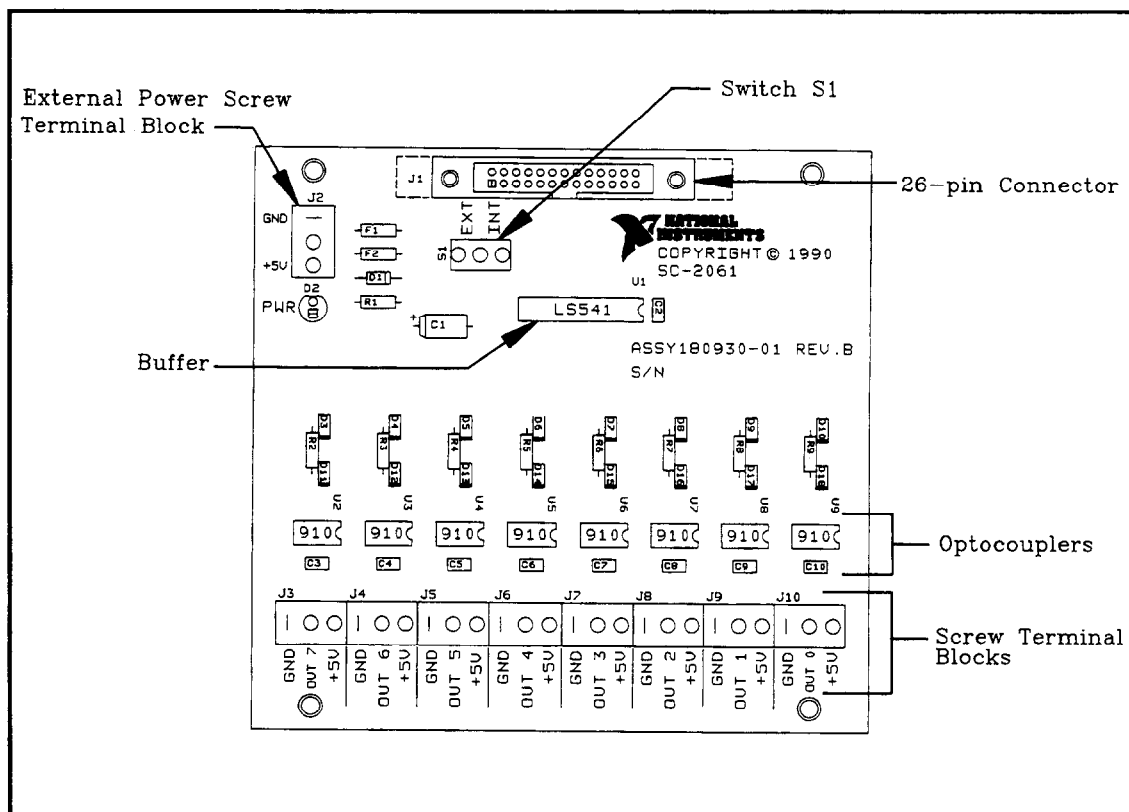

Figure 3-1. SC-2061 Board Parts Locator Diagram

The 26-pin connector (J1) attaches to the appropriate SC-205X Series board via a 26-pin conductor cable. You can connect an external +5 V power supply to the external power screw terminal block (J2) if required. To determine if an external +5 V supply is necessary, refer to *Internal or External Power Selection* in Chapter 5. Switch S1 selects between internal and external power. The buffer improves the logic levels of the inputs from the optocouplers to the

The output channels are labeled *OUT0* through *OUT7* at the screw terminals. The SC-2061 has three screw terminals per channel—GND, *OUT_x*, where *x* is any channel number (0 through 7), and +5 V. The lines between +5 V and GND indicate the boundary between channels. The digital output of the SC-2061 is positive logic; that is, high output states from the data acquisition board create high output at the screw terminals. The SC-2061 has eight channels of optocoupler output. The digital output signal and its reference ground must connect at the screw terminals. A +5 VDC power supply must also connect at the screw terminals. The digital output signal must be pulled up. National Instruments recommends using a 4.7 kΩ resistor to the +5 VDC line for the SC-2061. Because the output lines are open-collector lines, you must use pullup resistors to obtain valid output from the board. Figure 3-2 shows the 5 V onboard equivalent circuit for the SC-2061 board.

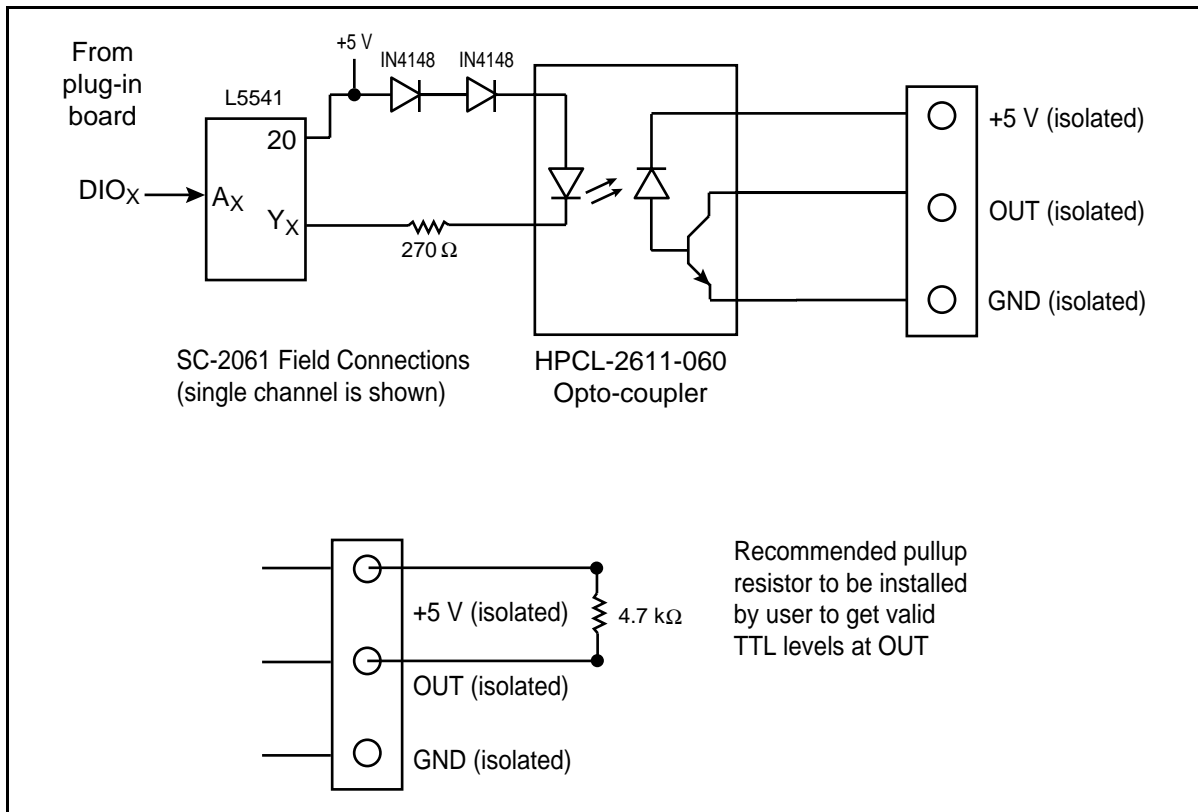

Figure 3-2. SC-2061 Onboard Equivalent Circuit

Warnings: When connecting or disconnecting signal lines to the screw terminals, you must power off the lines. Potential differences between the lines and the SC-2061 ground create a shock hazard while connecting the lines.

Connections, including power signals to ground and vice versa, that exceed any of the maximum input or output signal ratings on the SC-2061 board can result in damage to any or all of the boards connected to the SC-206X Series, to the host computer, and to the SC-2061 board. National Instruments is not liable for any damages resulting from incorrect signal connections.

Specifications

The following sections list the specifications of the SC-2061 digital signal conditioning accessory board. These ratings are typical at 25° C unless otherwise stated. The operating temperature range for this board is 0° to 70° C.

Optically Isolated Digital Output

Number of channels	Eight
Isolation	
Working voltage	250 Vrms channel-to-channel 300 Vrms channel-to-ground
Note:	This product complies with IEC-1010 for Voltage Installation Category II Pollution Degree 2.
Common-mode rejection	
Typical	500 V/ μ s
Minimum	100 V/ μ s
Data rate	Up to maximum speed of host board (500 kHz)
Propagation delay	
Typical (with 4.7 k Ω pullup to +5 VDC)	$t_{PLH} = 110$ ns $t_{PHL} = 45$ ns
Output	
Type	Open-collector
Compatibility	TTL-compatible
Fan-out	10 (using 4.7 k Ω pullup resistor at +5 VDC)
Voltage	Must pull up to +5 VDC only
Low level output current	15 mA (using 350 Ω pullup resistor at +5 VDC)
Field connections	Three screw terminals per channel

Power Requirement (from Host Board or External Power Supply)

Power consumption (at +5 VDC)	
Typical	21 mA \pm 5% with all outputs low 77 mA \pm 5% with all outputs high
Maximum	130 mA

Note: The power specifications pertain to the power supply of the host computer when using internal power or to the external supply connected at screw terminal J2 when using external power.

Physical

Board dimensions (including standoffs) 5.2 by 4.9 by 1.8 in.
 I/O connectors One 26-pin male ribbon-cable connector
 26 screw terminals

Operating Environment

Temperature 0° to 70° C
 Relative humidity 5% to 90% noncondensing

Storage Environment

Temperature -55° to 125° C
 Relative humidity 5% to 90% noncondensing

Mounting and Connection to Data Acquisition Boards

The SC-2061 has metal standoffs so the board can sit on a workbench near the host computer. You can use an optional rack-mount chassis, which can be fitted with a flat acrylic plastic cover. The SC-2061 grounds to its metal standoffs, and thus to the rack, when it is mounted in the chassis.

Warning: The SC-2061 *must be completely enclosed* if any onboard voltages or voltage differences across the optoisolators can exceed 30 V.

The SC-2061 connects to the data acquisition boards listed in Table 3-1 via the appropriate SC-205X Series cable adapter board.

Table 3-1. Data Acquisition Boards for Use with the SC-2061 Board

	SC-205X Series Boards				
	SC-2050	SC-2051	SC-2052	SC-2053	SC-2054
Host Data Acquisition Boards	AT-MIO-16 AT-MIO-16D AT-MIO-16F-5 AT-MIO-16X AT-MIO-64F-5 MC-MIO-16 NB-MIO-16 NB-MIO-16X	AT-MIO-16D MC-DIO-24 NB-DIO-24 PC-DIO-24	AT-DIO-32F MC-DIO-32F NB-DIO-32F	Lab-LC Lab-NB Lab-PC+	PC-DIO-96

A 26-pin ribbon cable connector connects the SC-2061 board to a digital I/O connector on an SC-205X Series cable adapter board. The SC-205X Series board connects to the data acquisition board with a 50-conductor or 100-conductor ribbon cable. You can connect the SC-2061 to any digital I/O port on any SC-205X Series board. The digital I/O port that is connected to the SC-2061 must be configured and operated on the data acquisition board as output only. For more information on mounting and connection, see Chapter 5, *Installation and Operation*.

Chapter 4

SC-2062 Board

This chapter describes the SC-2062 board in detail including function, compatibility, specifications, mounting, and connection.

With the SC-2062 board, you can easily control many field digital signals with a computer equipped with a National Instruments data acquisition board. With the appropriate SC-205X Series board, the SC-2062 connects to the digital ports of any board in the SC-205X Series. Therefore, the SC-2062 can provide relay output for the National Instruments data acquisition boards for the Macintosh II, IBM PS/2 Micro Channel, and PC/XT/AT computers.

The SC-2062 electromechanical relay digital output board has eight single-pole, dual-throw (SPDT) relays controlled by the eight digital lines connected to the SC-2062 board. Each of these relays has a normally closed (NC) contact that is connected to the common (COM) contact when the corresponding digital output line is low and a normally open (NO) contact that is connected to the COM contact when the digital line is high. The contacts are break-before-make so that all three contacts are never shorted. Working voltage isolation from contact-to-coil and from contact-to-contact is a maximum of 250 Vrms.

Figure 4-1 shows the parts locator diagram for the SC-2062 board.

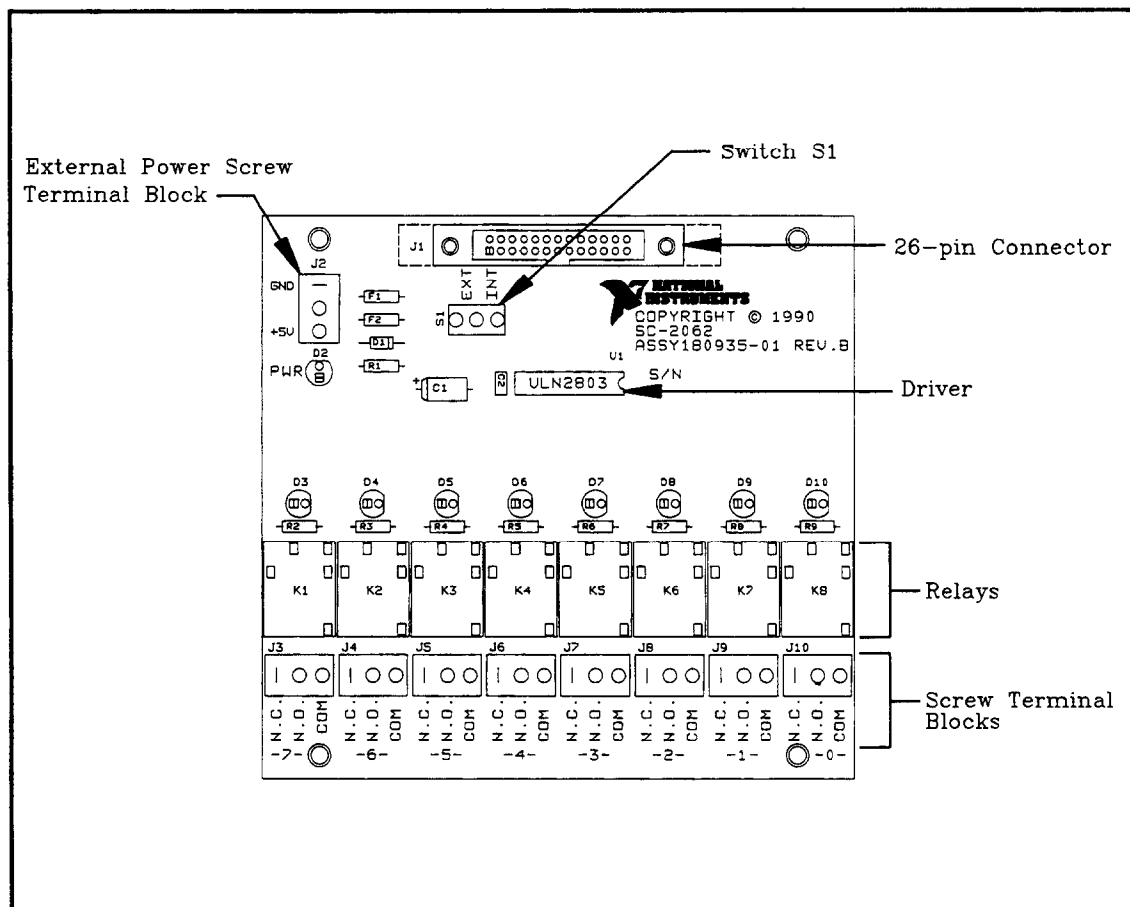

Figure 4-1. SC-2062 Board Parts Locator Diagram

The 26-pin connector (J1) attaches to the appropriate SC-205X Series board via a 26-pin conductor cable. You can connect an external +5 V power supply to the external power screw terminal block (J2) if required. To determine if an external +5 V supply is necessary, refer to *Internal or External Power Selection* in Chapter 5. Switch S1 selects between internal and external power. The driver amplifies the logic-level signals from the host data acquisition board to levels sufficient to drive the relays. The relays open and close connections made at the screw terminals (J3 through J10).

There are three connections per channel—NC, NO, and COM. There is a small gap between screw terminal blocks of adjacent channels. Figure 4-1 shows the locations of the screw terminals and other major board components.

The SC-2062 has eight sets of relay contacts. While a channel receives a low output signal, the relay for that channel remains unenergized and the NC contact shorts to COM while the NO contact remains open. When a high output signal is present on a channel, the relay for that channel is energized, and the NO contact shorts to COM while the NC contact is open. A green indicator LED just above each relay illuminates when the relay is energized. Each energized relay requires about 60 mA, so power consumption goes up dramatically as the number of energized relays increases. To reduce power consumption and to help extend relay life, control the signals so that relays are energized for only the shortest periods of time and simultaneously a minimal number of relays are energized. Figure 4-2 shows the 5 V onboard equivalent circuit for the SC-2062 board.

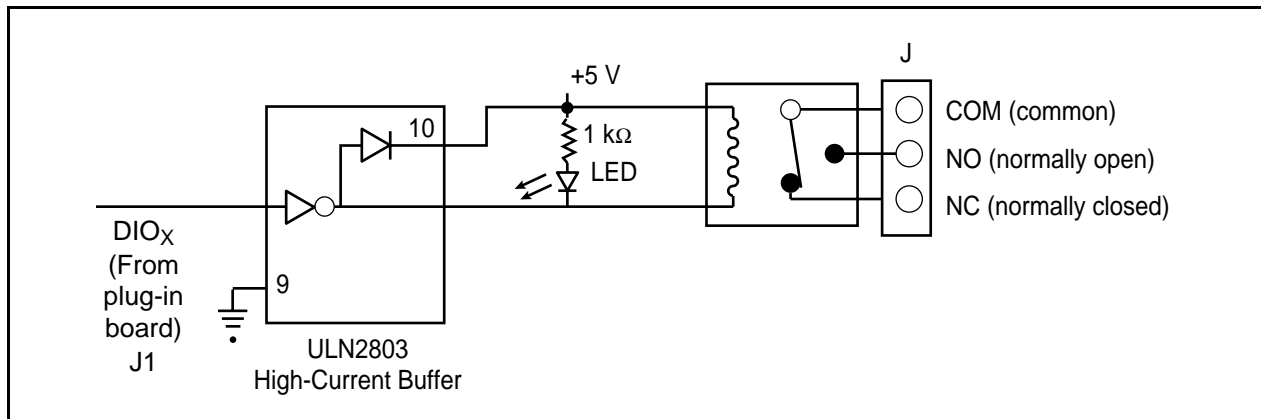

Figure 4-2. SC-2062 5 V Onboard Equivalent Circuit

Warnings: When connecting or disconnecting signal lines to the screw terminals, you must power off the lines. Potential differences between the lines and the SC-2062 ground create a shock hazard while connecting the lines.

Connections, including power signals to ground and vice versa, that exceed any of the maximum input or output signal ratings on the SC-2062 can result in damage to any or all of the boards connected to the SC-206X Series, to the host computer, and to the SC-2062 board. National Instruments is *not* liable for any damages resulting from incorrect signal connections.

Specifications

The following sections list the specifications of the SC-2062 digital signal conditioning accessory board. These ratings are typical at 25° C unless otherwise stated. The operating temperature range for this board is 0° to 70° C.

Electromechanical Relay Digital Output

Digital Input	
I_{in} (ON)	0.93 mA at 3.85 V
I_{in} (OFF)	65 μ A
Number of channels	Eight
Relay type	SPDT (1 Form C) Break-before-make
Contact material	Gold-plated silver nickel
Contact rating	
Noninductive load	6 A at 30 VDC or 250 VAC 170 W or 1,800 VA maximum
Contact life	
Mechanical	2×10^7 operations
Electrical	1×10^5 operations (at 6 A, 24 VDC, or 120 VAC)
Contact resistance	
Initially	100 m Ω maximum
At end of life	200 m Ω maximum
Working voltage	250 Vrms contact-to-contact 250 Vrms contact-to-ground
Note:	This product complies with IEC-1010 for Voltage Installation Category II Pollution Degree 2.
Turn-on delay (operate time)	
Typical	5 ms
Maximum	6 ms
Turn-off delay (release time)	
Typical	3 ms
Maximum	3 ms

Power Requirement (from Host Board or External Power Supply)

Field connections	3 screw terminals per channel
Power consumption (at +5 VDC)	
All relays energized (typical)	490 mA \pm 5%
No relays energized (typical)	10 mA \pm 5%
Maximum	630 mA

Note: The power specifications pertain to the power supply of the host computer when using internal power or to the external supply connected at screw terminal J2 when using external power.

Physical

Board dimensions (including standoffs)	5.2 by 4.9 by 1.8 in.
I/O connectors	One 26-pin male ribbon-cable connector 26 screw terminals

Operating Environment

Temperature	0° to 70° C
Relative humidity	5% to 90% noncondensing

Storage Environment

Temperature	-55° to 130° C
Relative humidity	5% to 90% noncondensing

Mounting and Connection to Data Acquisition Boards

The SC-2062 has metal standoffs so the board can sit on a workbench near the host computer. You can use an optional rack-mount chassis, which can be fitted with a flat acrylic plastic cover. The SC-2062 grounds to its metal standoffs, and thus to the rack, when it is mounted in the chassis.

Warning: The SC-2062 *must be completely enclosed* if any onboard voltages or any voltages connected to the relays can exceed 30 V.

The SC-2062 connects to the data acquisition boards listed in Table 4-1 via the appropriate SC-205X Series cable adapter board.

Table 4-1. Data Acquisition Boards for Use with the SC-2062 Board

	SC-205X Series Boards				
	SC-2050	SC-2051	SC-2052	SC-2053	SC-2054
Host Data Acquisition Boards	AT-MIO-16 AT-MIO-16D AT-MIO-16F-5 AT-MIO-16X AT-MIO-64F-5 MC-MIO-16 NB-MIO-16 NB-MIO-16X	AT-MIO-16D MC-DIO-24 NB-DIO-24 PC-DIO-24	AT-DIO-32F MC-DIO-32F NB-DIO-32F	Lab-LC Lab-NB Lab-PC+	PC-DIO-96

A 26-pin ribbon cable connector connects the SC-2062 board to a digital I/O connector on an SC-205X Series cable adapter board. The SC-205X Series board connects to the data acquisition board with a 50-conductor or 100-conductor ribbon cable. You can connect the SC-2062 to any digital I/O port on any SC-205X Series board. The digital I/O port that is connected to the SC-2062 must be configured and operated on the data acquisition board as output only. For more information on mounting and connection, see Chapter 5, *Installation and Operation*.

Chapter 5

Installation and Operation

This chapter describes the hardware installation, signal connections, and operation of the SC-206X Series boards.

Hardware Installation

The following are general instructions for installing your SC-206X Series board in your computer data acquisition system. Consult your computer user manual or technical reference manual for specific instructions and warnings. Notice that the installation instructions are the same for each SC-206X Series board.

1. Turn the host computer off before making any connections.
2. Install the SC-205X Series cable adapter board that is compatible with the host data acquisition board you are using. Consult the *SC-205X Series User Manual* for instructions on the installation of your SC-2050, SC-2051, SC-2052, SC-2053, or SC-2054 board.
3. It is advisable to use a 19 in. mounting rack or some other protective enclosure if you are using the SC-206X Series board with high voltage. If you are not using high voltage, skip to Step 4.

Warning: The SC-206X Series boards are for use where high-voltage isolation is necessary or desired. To ensure operator safety, these boards must be mounted in a suitable enclosure if they are connected to circuits that may have high voltages (greater than 42 V peak). The rack-mount kit alone with the acrylic plastic cover does not provide adequate operator protection unless additional coverage is provided on the top and bottom. Remember to turn the power off when making any connections to any of these boards, unless the top and bottom are also covered to prevent unintentional contact with high voltage wiring.

- a. Your SC-206X Series board mounts on one-third of a 19-in. rack chassis. You can mount two SC-206X Series boards alongside any SC-205X Series cable adapter board except the SC-2054 board, which occupies half of the rack chassis. You can mount your SC-206X Series board on the left side, in the center, or on the right side of the 19-in. rack mount as shown in Figure 5-1.

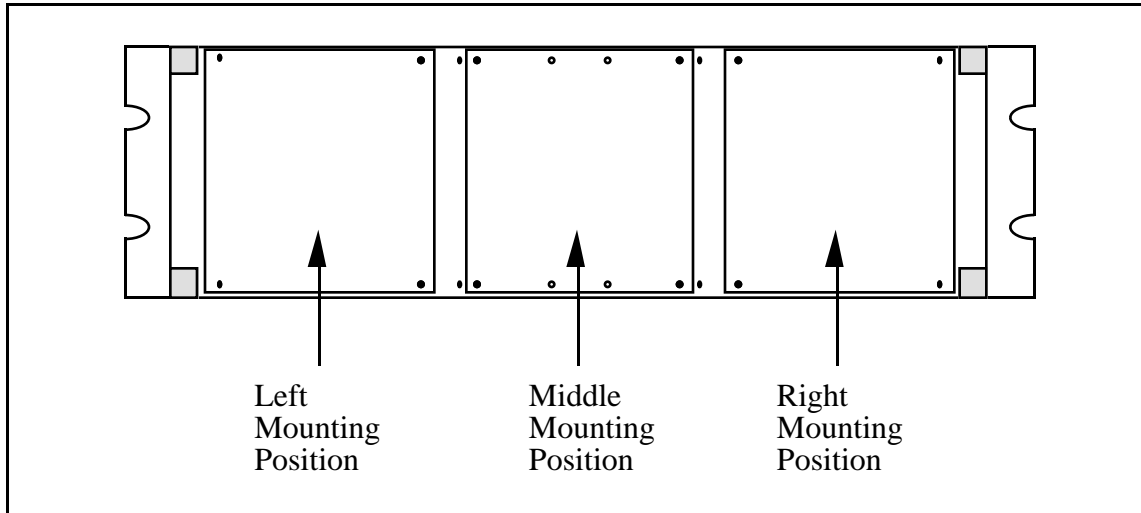

Figure 5-1. Mounting Locations for SC-205X and SC-206X Series Boards

- b. Remove the screws on the bottoms of the four standoffs attached to the board. Use the same screws to mount your SC-206X Series board to the rack chassis as shown in Figure 5-2. Put the washers around the screws before you screw them to the rack.

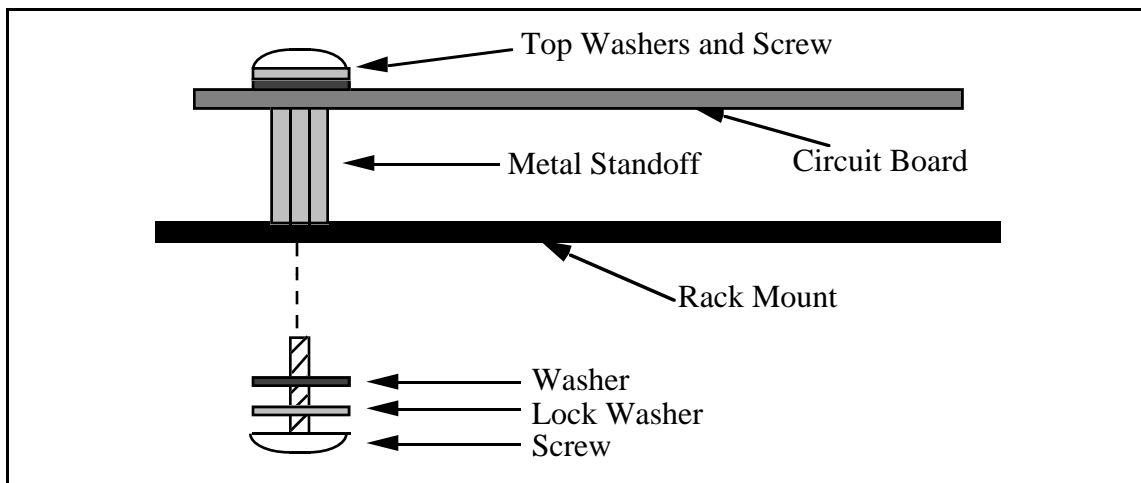

Figure 5-2. Attaching a Mountable Board to the Chassis

Notice that the ground for the SC-206X Series board is connected to the metal standoffs attached to the board. Rack mounting automatically grounds the board to the metal chassis.

- If you are planning to use more than two SC-206X Series boards with one SC-205X Series board, double-height mounting within one rack-mount chassis is possible. You need a hardware kit for double-height mounting (see *Optional Equipment* in Chapter 1), which consists of two brackets that mount in the rack mount. You can mount a second row of SC-205X Series and SC-206X Series boards on these brackets the same way you mount the first row. Figure 5-3 illustrates double-height mounting.

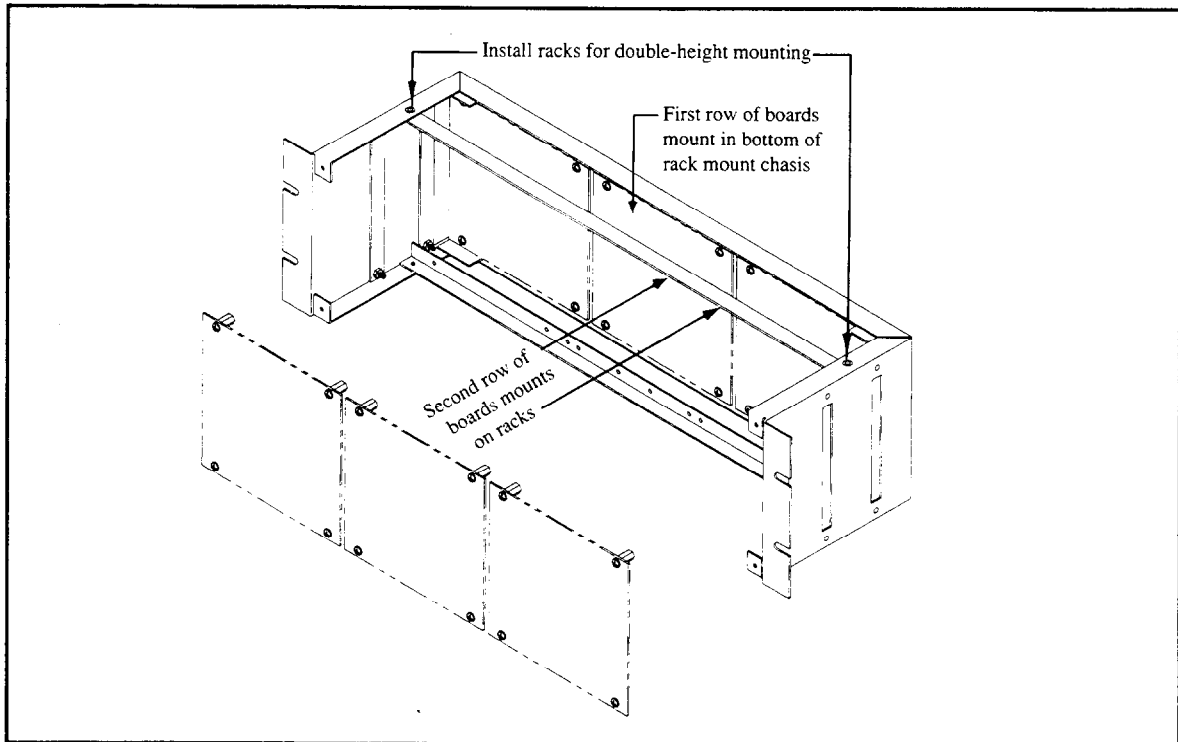

Figure 5-3. Double-Height Mounting

4. Connect the external power lines to the SC-206X Series board (if required). See *Internal or External Power Selection* later in this chapter to determine whether external power is required.
5. Connect the SC-206X Series board to the SC-205X Series board using type SC1 ribbon cable.
6. Connect the field signals to the SC-206X Series board at the screw terminals.
7. Repeat steps three through five to install and connect any additional boards.
8. If desired, attach the appropriate cover to the rack mount. The optional 19-in. rack-mount accessory (type DA1) kit includes a flat acrylic plastic cover. You install the cover by sliding it over the rack-mount brackets and using the four screws included in the kit.
9. If the SC-206X Series board has an external +5 V supply, turn the power supply on now. A red LED labeled *PWR* illuminates when the board is receiving power.
10. Turn the computer on.
11. When finished, turn off the computer before turning off any external power supplies for the SC-206X Series board.

Internal or External Power Selection

Switch S1 on each SC-206X Series board selects internal or external +5 V power for that board. If you set S1 to the position labeled *INT*, the host computer powers the SC-206X Series board via the host data acquisition board. If you set S1 to the position labeled *EXT*, the SC-206X Series board is powered from an external +5 V source connected to the J2 connector located near the J1 26-pin header.

In many cases, the host data acquisition board can supply enough power to run the SC-206X Series boards. If the total +5 V power drawn by external accessories (such as the SC-206X Series boards, the SC-2070 or SC-2071 boards, the AMUX-64T board, and SSR Series boards) exceeds the power remaining, then some of these accessories must be powered by an external +5 V supply. Also, any accessories connected to a DIO-32F board *must* be powered externally because this board does not supply +5 V power. Table 5-1 shows the amount of power that each data acquisition board can supply to external accessories.

Table 5-1. Amount of Power Data Acquisition Boards Supply

Board	Allotted Power by Slot	Power Used by Board	Power from Board Available for Accessories
Lab-NB	2.0 A	0.8 A	1 A ¹
NB-DIO-24	2.0 A	0.8 A	1.0 A ¹
NB-DIO-32F	2.0 A	1.6 A	0 A ²
NB-MIO-16	2.0 A	1.5 A	0.5 A
NB-MIO-16X	2.0 A	1.4 A	0.25 A ¹
AT-DIO-32F	No Restriction	1.28 A	0 A ²
AT-MIO-16	No Restriction	1.5 A	1 A ¹
AT-MIO-16D	No Restriction	1.7 A	1 A ¹
AT-MIO-16F-5	No Restriction	1.7 A	1 A ¹
AT-MIO-16X	No Restriction	1.6 A	1 A ¹
Lab-PC	No Restriction	0.6 A	1 A ¹
Lab-PC+	No Restriction	0.15 A	1 A ¹
PC-DIO-24	No Restriction	0.16 A	1 A ¹
PC-DIO-96	No Restriction	0.45 A	1 A ¹
MC-DIO-24	1.6 A	0.8 A	0.8 A
MC-DIO-32F	1.6 A	1.4 A	0 A ²
MC-MIO-16	1.6 A	1.4 A	0.2 A

¹ These limitations are caused by a series fuse on the +5 V out on these boards, rather than the remaining power per slot.

² DIO-32F boards do not supply +5 V power.

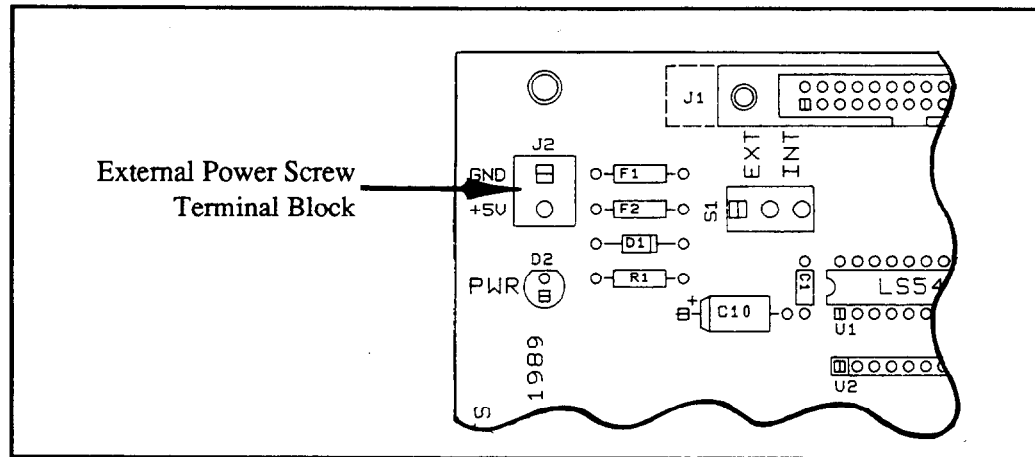

Figure 5-4. Location of the External Power Screw Terminals

Switch S1, located near the ribbon cable connector J1, selects internal or external power (see Figure 5-5). To use external power, set this switch to the position labeled EXT. To use internal power, set the switch to the position labeled INT. Figure 5-5 illustrates these switch settings. The SC-206X Series boards are shipped from the factory with switch S1 set for internal power.

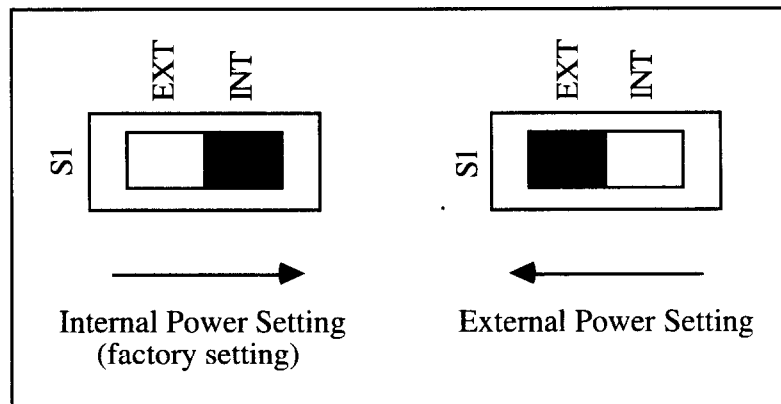

Figure 5-5. Power Selection Settings for Switch S1

SC-206X Series Board Connection

Each of the SC-206X Series boards is connected to the host data acquisition board—NB Series, MC Series, AT Series, or Lab board—via an SC-205X Series cable adapter board. Figure 5-6 illustrates the connections between the host board and the SC-205X Series boards and between the SC-205X Series and the SC-206X Series boards. For more information on the SC-205X Series boards, see the *SC-205X Series User Manual*.

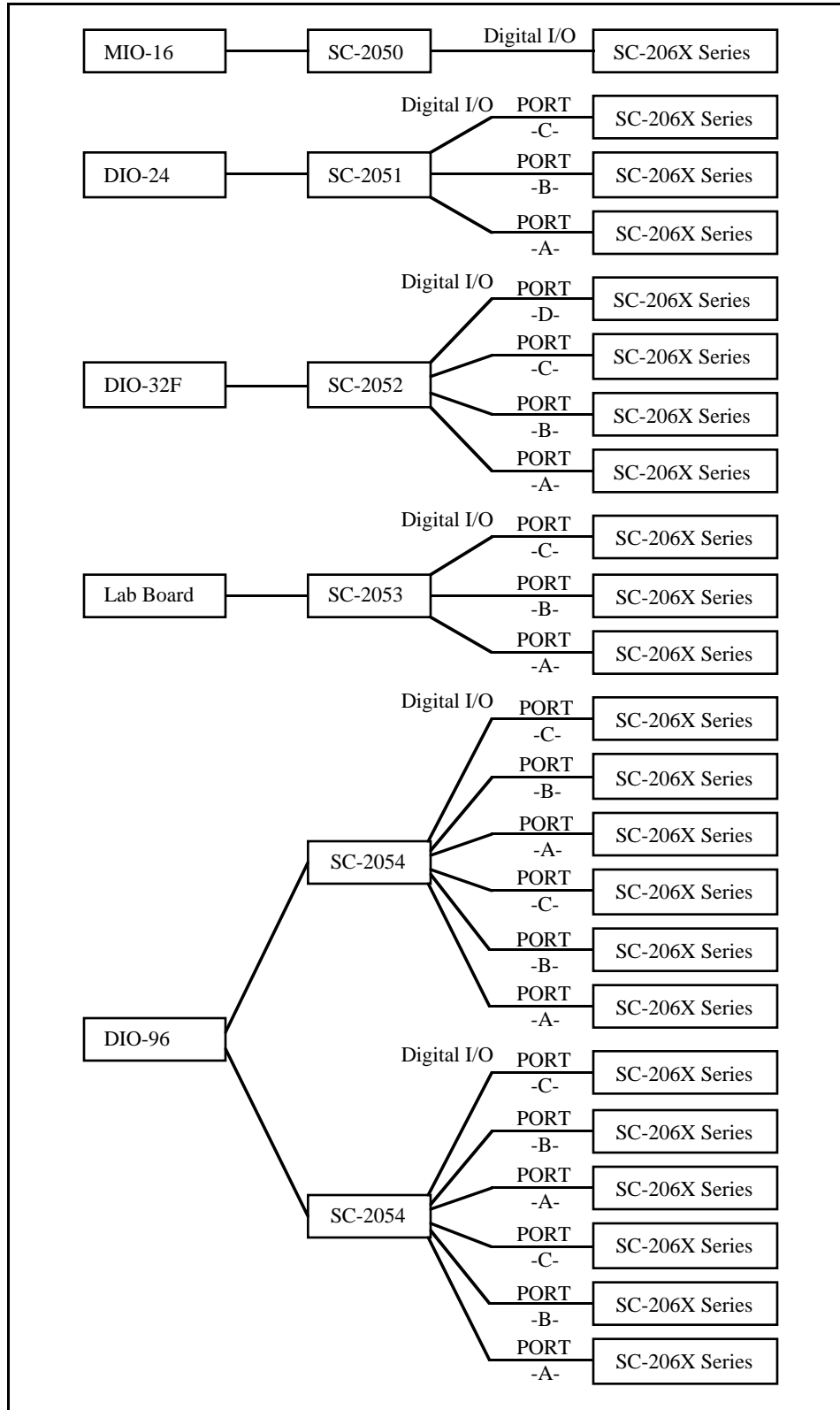

Figure 5-6. Connecting SC-206X Series Boards to Data Acquisition Boards via the SC-205X Series Cable Adapter Boards

For more detailed information about the SC-206X Series boards, see Chapter 2, *SC-2060 Board*, Chapter 3, *SC-2061 Board*, or Chapter 4, *SC-2062 Board*.

A 26-pin ribbon cable (type SC1) connects your SC-206X Series board to an SC-205X Series board. Remember to turn the computer or any other device off before making any connections. One end of the ribbon cable connects to the SC-206X Series board at connector J1.

Figure 5-7 shows the pinouts for cable connector J1 on your SC-206X Series boards.

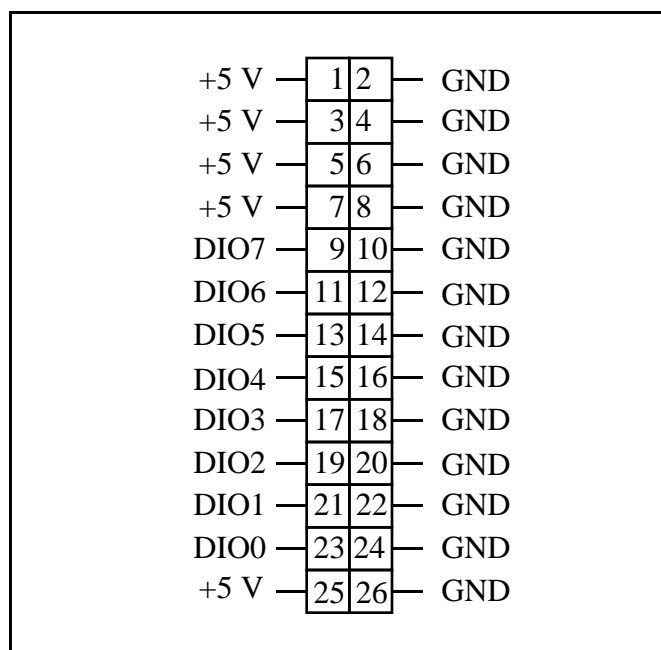

Figure 5-7. Pinout for I/O Connector J1

Pins	Signal Names	Description
9, 11, 13, 15, 17, 19, 21, 23	DIO<0..7>	Digital data lines—DIO7 is the most significant bit; DIO0 is the least significant bit.
1, 3, 5, 7, 25	+5 V	Power from host computer—When you set switch S1 to the position labeled <i>INT</i> , these pins are connected to power connections on the SC-206X Series. When you set switch S1 to the position labeled <i>EXT</i> , these pins are disconnected from parts on the SC-206X Series.
2, 4, 6, 8, 10, 12, 14, 16, 18, 20, 22, 24, 26	GND	Ground—These pins are connected to the ground signal of the SC-206X Series board.

Connector J1 is for connection only to an SC-205X Series board at a 26-pin connector labeled *Digital I/O* (see Table 5-2). Incorrect connection can result in damage to the SC-206X Series board and all components connected to the SC-206X Series board, including the host computer. Remember to turn the host computer off before making any connections. For further information concerning the signal connections on the SC-205X Series cable adapter boards, consult your *SC-205X Series User Manual*.

The other end of the ribbon cable connects to the SC-205X Series board that you have installed for use with the host data acquisition board. You should connect your SC-206X Series board only to the 26-pin connector labeled *DIGITAL I/O* on your SC-205X Series board. Table 5-2 lists these connectors.

Table 5-2. SC-205X Series Connectors Compatible with SC-206X Series

Board	Connector
SC-2050 (for MIO-16 boards)	Connector J5, DIGITAL I/O
SC-2051 (for DIO-24 boards)	Connector J3, DIGITAL I/O, PORT -C- Connector J4, DIGITAL I/O, PORT -B- Connector J5, DIGITAL I/O, PORT -A-
SC-2052 (for DIO-32F boards)	Connector J3, DIGITAL I/O, PORT -D- Connector J4, DIGITAL I/O, PORT -C- Connector J5, DIGITAL I/O, PORT -B- Connector J6, DIGITAL I/O, PORT -A-
SC-2053 (for Lab-NB, Lab-PC, and Lab-PC+ boards)	Connector J4, DIGITAL I/O, PORT -C- Connector J5, DIGITAL I/O, PORT -B- Connector J6, DIGITAL I/O, PORT -A-
SC-2054 (for DIO-96 boards)	Connector J4, DIGITAL I/O, PPI A/C PORT -C- Connector J5, DIGITAL I/O, PPI A/C PORT -B- Connector J6, DIGITAL I/O, PPI A/C PORT -A- Connector J8, DIGITAL I/O, PPI B/D PORT -C- Connector J9, DIGITAL I/O, PPI B/D PORT -B- Connector J10, DIGITAL I/O, PPI B/D PORT -A-
<p>Warning: Do not attempt to connect an SC-206X Series board to any connector for which it is not designed. Incorrect connection can result in damage to the SC-206X Series board and all components connected to the SC-206X Series board, including the host computer. National Instruments is not liable for any damages resulting from incorrect connections.</p>	

The SC-206X Series board operates on the digital port to which it is connected. For example, if you want digital input isolation on Port B of a DIO-24 board, connect an SC-2060 board to an SC-2051 board at connector J4, labeled *DIGITAL I/O, PORT -B-*.

Operation

An SC-206X Series board operates on the 8-bit digital port corresponding to the label on its SC-205X Series connection. To change the digital port that is being conditioned, simply disconnect the SC-206X Series board from the current port on the SC-205X Series board and reconnect it to the desired port. Power to the host computer and all external circuitry must be *off* while disconnecting and connecting an SC-206X Series board.

Notice that the SC-2060 board has only input capability. Therefore, you must configure and operate the digital port used with the SC-2060 board as only an input port. Likewise, the SC-2061 and SC-2062 boards have only output capability. You must configure the digital ports used with either the SC-2061 board or the SC-2062 board for only digital output.

When using an SC-206X Series board with an MIO-16 and SC-205X Series board, the 8-bit digital port connected to the signal conditioning board consists of *both* port A and port B (4-bit ports) from the MIO-16.

Note: For the MIO-16 boards, both port A and port B are used together as a single 8-bit port. Port A bits 0 through 3 correspond to SC-206X Series channels 0 through 3 and Port B bits 0 through 3 correspond to SC-206X Series channels 4 through 7.

In this case, you must configure both 4-bit ports to match the operation of the SC-206X Series, that is, input for the SC-2060 board or output for either the SC-2061 or SC-2062 boards.

Safety Information



Caution: *DO NOT OPERATE THE DEVICE IN AN EXPLOSIVE ATMOSPHERE OR WHERE THERE MAY BE FLAMMABLE GASES OR FUMES.*

Equipment described in this document must be used in an Installation Category II environment per IEC 664. This category requires local level supply mains-connected installation.

DO NOT OPERATE DAMAGED EQUIPMENT. The safety protection features built into this device can become impaired if the device becomes damaged in any way. If the device is damaged, turn the device off and do not use until service-trained personnel can check its safety. If necessary, return the device to National Instruments for service and repair to ensure that its safety is not compromised.

Do not operate this equipment in a manner that contradicts the information specified in this document. Misuse of this equipment could result in a shock hazard.

Terminals are for use only with equipment that has no accessible live parts.

DO NOT SUBSTITUTE PARTS OR MODIFY EQUIPMENT. Because of the danger of introducing additional hazards, do not install unauthorized parts or modify the device. Return the device to National Instruments for service and repair to ensure that its safety features are not compromised.

When using the device with high common-mode voltages, you MUST insulate your signal wires for the highest input voltage. National Instruments is NOT liable for any damages or injuries resulting from inadequate signal wire insulation. Use only 26-14 AWG wire with a voltage rating of 300 V and 60° C for controlling 250 V. Prepare your signal wire by stripping the insulation no more than 7 mm.

KEEP AWAY FROM LIVE CIRCUITS. When connecting or disconnecting signal lines to the terminal block screw terminals, make sure the lines are powered off. Potential differences between the lines and ground create a shock hazard while you connect the lines.

Connect the signal wires to the screw terminals by inserting the stripped end of the wire fully into the terminals. Tighten the terminals to a torque of 5-7 in.-lb.

Connections, including power signals to ground and vice versa, that exceed any of the maximum signal ratings on the device can create a shock or fire hazard or can damage any or all of the boards connected to the device and the host computer, and the device itself. National Instruments is NOT LIABLE FOR ANY DAMAGES OR INJURIES resulting from incorrect signal connections.

Clean devices and terminal blocks by brushing off light dust with a soft, nonmetallic brush. Remove other contaminants with deionized water and a stiff nonmetallic brush. The unit must be completely dry and free from contaminants before returning to service.

Appendix A

HCPL-2611-060 Technical Data*

This appendix contains technical data on the Hewlett-Packard Company HPCL-2611-060 high-speed TTL compatible optocoupler. The HCPL-2611-060 is used on the SC-2060 and the SC-2061.

* Copyright © Hewlett-Packard Company. Reprinted with permission of copyright owner. All rights reserved.



High CMR, High Speed TTL Compatible Optocoupler

Technical Data

6N137	
HCNW137	HCPL-0631
HCNW2601	HCPL-0661
HCNW2611	HCPL-2601
HCPL-0600	HCPL-2611
HCPL-0601	HCPL-2630
HCPL-0611	HCPL-2631
HCPL-0630	HCPL-4661

Features

- 5 kV/ μ s Minimum Common Mode Rejection (CMR) at $V_{CM} = 50$ V for HCPL-X601/X631, HCNW2601 and 10 kV/ μ s Minimum CMR at $V_{CM} = 1000$ V for HCPL-X611/X661, HCNW2611
- High Speed: 10 MBd Typical
- LSTTL/TTL Compatible
- Low Input Current Capability: 5 mA
- Guaranteed ac and dc Performance over Temperature: -40°C to $+85^{\circ}\text{C}$
- Available in 8-Pin DIP, SOIC-8, Widebody Packages
- Strobable Output (Single Channel Products Only)
- Safety Approval
UL Recognized - 2500 V rms for 1 minute and 5000 V rms* for 1 minute per UL1577
CSA Approved
VDE 0884 Approved with $V_{FORM} = 630$ V peak for HCPL-2611 Option 060 and $V_{FORM} = 1414$ V peak for HCNW137/26X1
BSI Certified (HCNW137/26X1 Only)
- MIL-STD-1772 Version Available (HCPL-56XX/66XX)

Applications

- Isolated Line Receiver
- Computer-Peripheral Interfaces
- Microprocessor System Interfaces
- Digital Isolation for A/D, D/A Conversion
- Switching Power Supply
- Instrument Input/Output Isolation
- Ground Loop Elimination
- Pulse Transformer Replacement

- Power Transistor Isolation in Motor Drives
- Isolation of High Speed Logic Systems

Description

The 6N137, HCPL-26XX/06XX/4661, HCNW137/26X1 are optically coupled gates that combine a GaAsP light emitting diode and an integrated high gain photo detector. An enable input allows the detector to be strobed. The output of the detector IC is

Functional Diagram

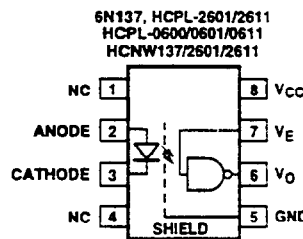

TRUTH TABLE (POSITIVE LOGIC)

LED	ENABLE	OUTPUT
ON	H	L
OFF	H	H
ON	L	H
OFF	L	H
ON	NC	L
OFF	NC	H

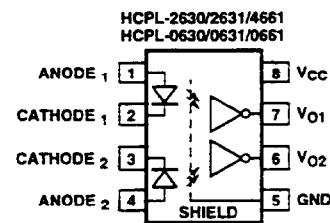

TRUTH TABLE (POSITIVE LOGIC)

LED	OUTPUT
ON	L
OFF	H

*5000 V rms/1 Minute rating is for HCNW137/26X1 and Option 020 (6N137, HCPL-2601/11/30/31, HCPL-4661) products only.

A 0.1 μ F bypass capacitor must be connected between pins 5 and 8.

CAUTION: It is advised that normal static precautions be taken in handling and assembly of this component to prevent damage and/or degradation which may be induced by ESD.

an open collector Schottky-clamped transistor. The internal shield provides a guaranteed common mode transient immunity specification of 5,000 V/ μ s for the HCPL-X601/X631 and HCNW2601, and 10,000 V/ μ s for the HCPL-X611/X661 and HCNW2611.

This unique design provides maximum ac and dc circuit isolation while achieving TTL compatibility. The optocoupler ac and dc operational parameters are guaranteed from -40°C to +85°C allowing troublefree system performance.

The 6N137, HCPL-26XX, HCPL-06XX, HCPL-4661, HCNW137, and HCNW26X1 are suitable for high speed logic interfacing, input/output buffering, as line receivers in environments that conventional line receivers cannot tolerate and are recommended for use in extremely high ground or induced noise environments.

Selection Guide

Minimum CMR		Input On-Current (mA)	Output Enable	8-Pin DIP (300 Mil)		Small-Outline SO-8		Widebody (400 Mil)	Hermetic Single and Dual Channel Packages
dV/dt (V/ μ s)	V _{CM} (V)			Single Channel Package	Dual Channel Package	Single Channel Package	Dual Channel Package	Single Channel Package	
NA	NA	5	YES	6N137		HCPL-0600		HCNW137	
			NO		HCPL-2630		HCPL-0630		
5,000	50		YES	HCPL-2601		HCPL-0601		HCNW2601	
			NO		HCPL-2631		HCPL-0631		
10,000	1,000		YES	HCPL-2611		HCPL-0611		HCNW2611	
			NO		HCPL-4661		HCPL-0661		
1,000	50	YES	HCPL-2602 ^[1]						
3,500	300	YES	HCPL-2612 ^[1]						
1,000	50	3	YES	HCPL-261A ^[1]		HCPL-061A ^[1]			
			NO		HCPL-263A ^[1]		HCPL-063A ^[1]		
1,000 ^[2]	1,000		YES	HCPL-261N ^[1]		HCPL-061N ^[1]			
			NO		HCPL-263N ^[1]		HCPL-063N ^[1]		
1,000	50	12.5	[3]					HCPL-193X ^[1] HCPL-56XX ^[1] HCPL-66XX ^[1]	

Notes:

1. Technical data are on separate HP publications.
2. 15 kV/ μ s with V_{CM} = 1 kV can be achieved using HP application circuit.
3. Enable is available for single channel products only, except for HCPL-193X devices.

Ordering Information

Specify Part Number followed by Option Number (if desired).

Example:

HCPL-2611#XXX

- _____ 020 = 5000 V rms/1 minute UL Rating Option*
- _____ 060 = VDE 0884 $V_{IORM} = 630$ Vpeak Option**
- _____ 300 = Gull Wing Surface Mount Option†
- _____ 500 = Tape and Reel Packaging Option

Option data sheets available. Contact: Hewlett-Packard sales representative or authorized distributor for information.

*For 6N137, HCPL-2601/11/30/31 and HCPL-4661 (8-pin DIP products) only.

**For HCPL-2611 only. Combination of Option 020 and Option 060 is not available.

†Gull wing surface mount option applies to through hole parts only.

Schematic

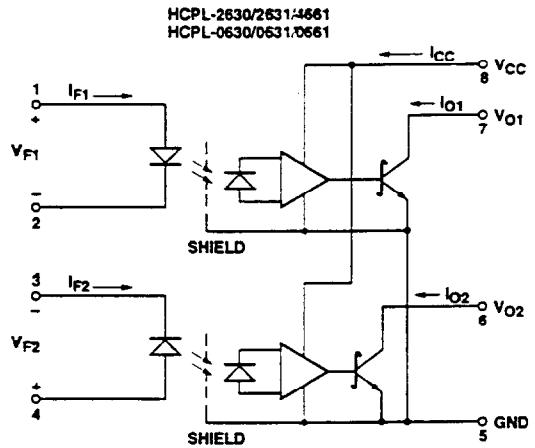
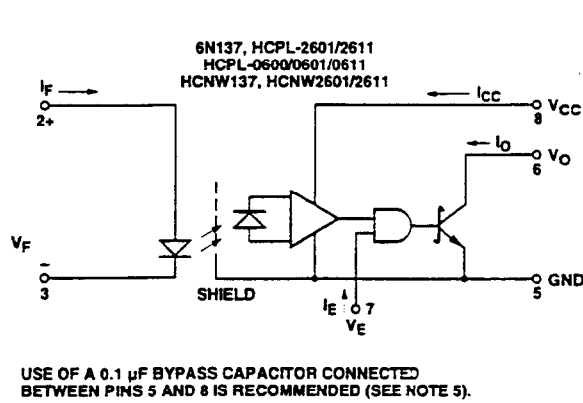

Package Outline Drawings

8-pin DIP Package (6N137, HCPL-2601/11/30/31, HCPL-4661)**

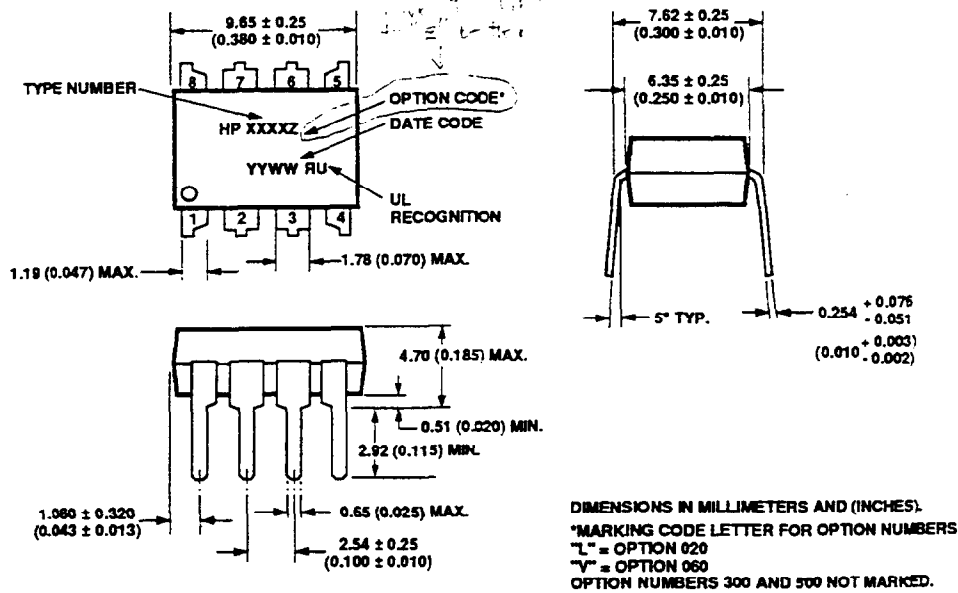

**JEDEC Registered Data (for 6N137 only).

8-pin DIP Package with Gull Wing Surface Mount Option 300 (6N137, HCPL-2601/11/30/31, HCPL-4661)

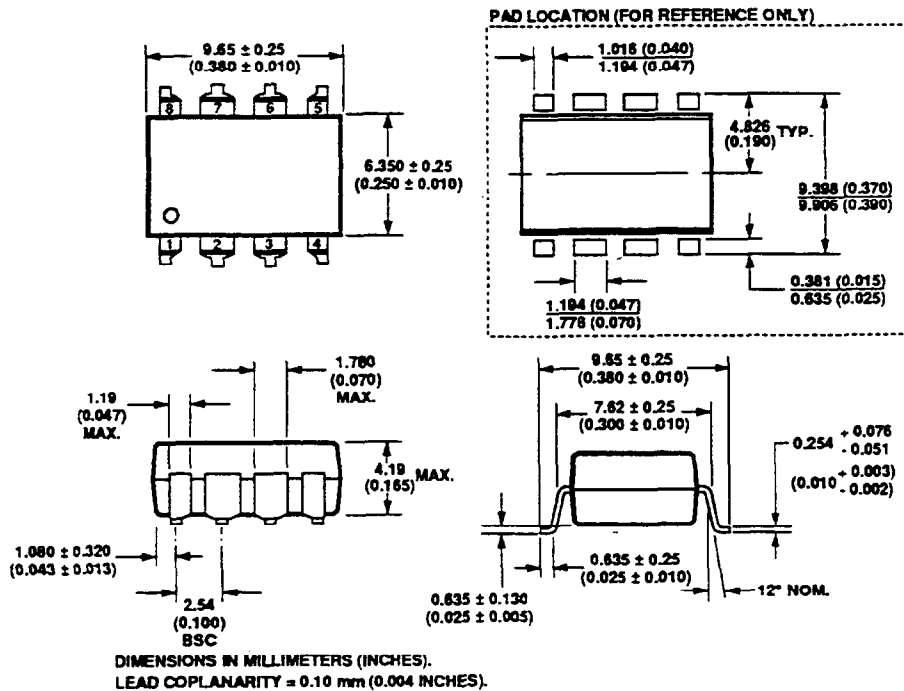

Small-Outline SO-8 Package (HCPL-0600/01/11/30/31/61)

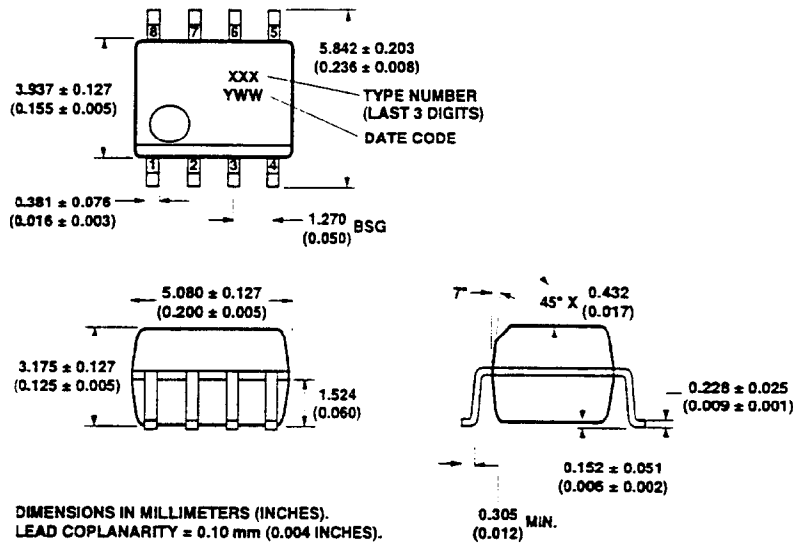

8-Pin Widebody DIP Package (HCNW137, HCNW2601/11)

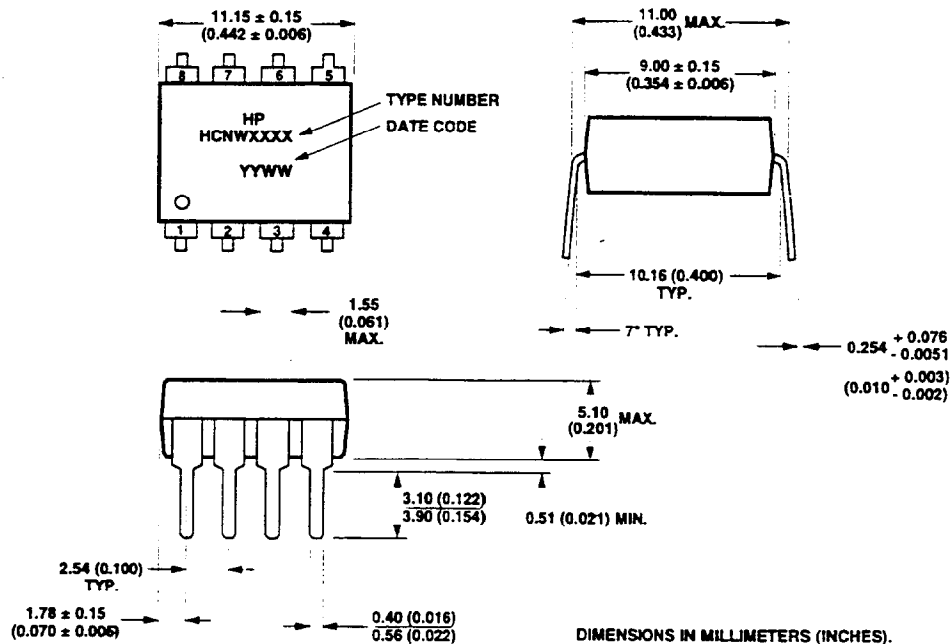

**8-Pin Widebody DIP Package with Gull Wing Surface Mount Option 300
(HCNW137, HCNW2601/11)**

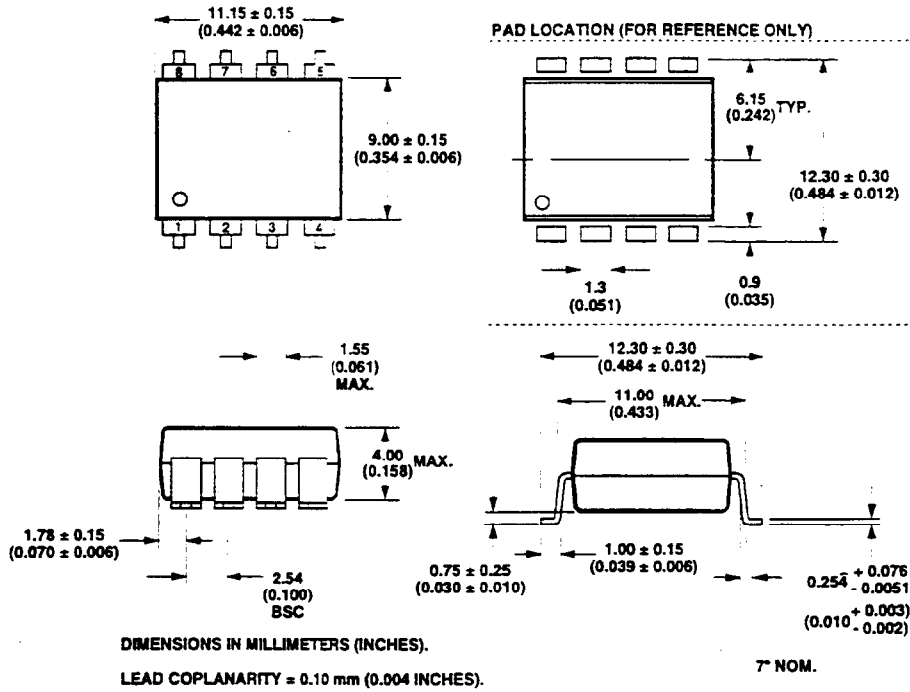

Solder Reflow Temperature Profile (HCPL-06XX and Gull Wing Surface Mount Option 300 Parts)

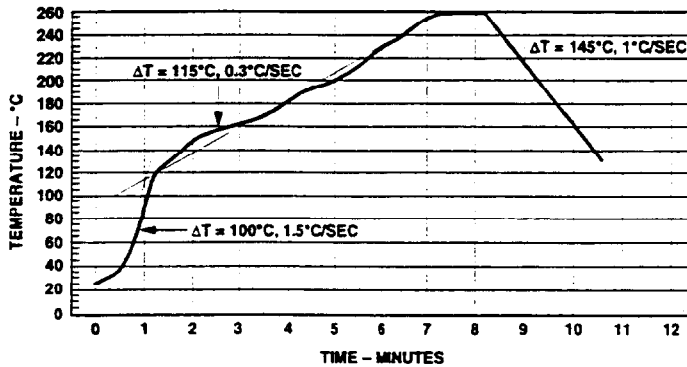

Note: Use of nonchlorine activated fluxes is highly recommended.

Regulatory Information

The 6N137, HCPL-26XX/06XX/46XX, and HCNW137/26XX have been approved by the following organizations:

UL

Recognized under UL 1577, Component Recognition Program, File E55361.

CSA

Approved under CSA Component Acceptance Notice #5, File CA 88324.

VDE

Approved according to VDE 0884/06.92. (HCPL-2611 Option 060 and HCNW137/26X1 only)

BSI

Certification according to BS415:1994 (BS EN60065:1994), BS7002:1992 (BS EN60950:1992) and EN41003:1993 for Class II applications. (HCNW137/26X1 only)

Insulation and Safety Related Specifications

Parameter	Symbol	8-pin DIP (300 Mil) Value	SO-8 Value	Widebody (400 Mil) Value	Units	Conditions
Minimum External Air Gap (External Clearance)	L(101)	7	4.97	9.6	mm	Measured from input terminals to output terminals, shortest distance through air.
Minimum External Tracking (External Creepage)	L(102)	7	4.83	10	mm	Measured from input terminals to output terminals, shortest distance path along body.
Minimum Internal Plastic Gap (Internal Clearance)		0.08	0.08	1.0	mm	Through insulation distance, conductor to conductor, usually the direct distance between the photoemitter and photodetector inside the optocoupler cavity.
Minimum Internal Tracking (Creepage)		NA	NA	4.0	mm	Measured from input terminals to output terminals, along internal cavity.
Tracking Resistance (Comparative Tracking Index)	CTI	200	200	200	Volts	DIN IEC 112/VDE 0303 Part 1
Isolation Group		IIIa	IIIa	IIIa		Material Group (DIN VDE 0110, 1/89, Table 1)

Option 300 - surface mount classification is Class A in accordance with CECC 00802.

VDE 0884 Insulation Related Characteristics (HCPL-2611 Option 060 Only)

Description	Symbol	Characteristic	Units
Installation classification per DIN VDE 0110/1.89, Table 1 for rated mains voltage ≤ 300 V rms for rated mains voltage ≤ 450 V rms		I-IV	
		I-III	
Climatic Classification		55/85/21	
Pollution Degree (DIN VDE 0110/1.89)		2	
Maximum Working Insulation Voltage	V_{IORM}	630	V peak
Input to Output Test Voltage, Method b* $V_{IORM} \times 1.875 = V_{PR}$, 100% Production Test with $t_m = 1$ sec, Partial Discharge < 5 pC	V_{PR}	1181	V peak
Input to Output Test Voltage, Method a* $V_{IORM} \times 1.5 = V_{PR}$, Type and sample test, $t_m = 60$ sec, Partial Discharge < 5 pC	V_{PR}	945	V peak
Highest Allowable Overvoltage* (Transient Overvoltage, $t_{ni} = 10$ sec)	V_{IOTM}	6000	V peak
Safety Limiting Values (Maximum values allowed in the event of a failure, also see Figure 16, Thermal Derating curve.)			
Case Temperature	T_S	175	$^{\circ}\text{C}$
Input Current	$I_{S,INPUT}$	230	mA
Output Power	$P_{S,OUTPUT}$	600	mW
Insulation Resistance at T_S , $V_{IO} = 500$ V	R_S	$\geq 10^9$	Ω

*Refer to the front of the optocoupler section of the current catalog, under Product Safety Regulations section (VDE 0884), for a detailed description.

Note: Isolation characteristics are guaranteed only within the safety maximum ratings which must be ensured by protective circuits in application.

VDE 0884 Insulation Related Characteristics (HCNW137/2601/2611 Only)

Description	Symbol	Characteristic	Units
Installation classification per DIN VDE 0110/1.89, Table 1 for rated mains voltage ≤ 600 V rms for rated mains voltage ≤ 1000 V rms		I-IV	
		I-III	
Climatic Classification (DIN IEC 68 part 1)		55/100/21	
Pollution Degree (DIN VDE 0110/1.89)		2	
Maximum Working Insulation Voltage	V_{IORM}	1414	V peak
Input to Output Test Voltage, Method b* $V_{IORM} \times 1.875 = V_{PR}$, 100% Production Test with $t_m = 1$ sec, Partial Discharge < 5 pC	V_{PR}	2651	V peak
Input to Output Test Voltage, Method a* $V_{IORM} \times 1.5 = V_{PR}$, Type and sample test, $t_m = 60$ sec, Partial Discharge < 5 pC	V_{PR}	2121	V peak
Highest Allowable Overvoltage* (Transient Overvoltage, $t_{ni} = 10$ sec)	V_{IOTM}	8000	V peak
Safety Limiting Values (Maximum values allowed in the event of a failure, also see Figure 16, Thermal Derating curve.)			
Case Temperature	T_S	150	$^{\circ}\text{C}$
Input Current	$I_{S,INPUT}$	400	mA
Output Power	$P_{S,OUTPUT}$	700	mW
Insulation Resistance at T_S , $V_{IO} = 500$ V	R_S	$\geq 10^9$	Ω

*Refer to the front of the optocoupler section of the current catalog, under Product Safety Regulations section (VDE 0884), for a detailed description.

Note: Isolation characteristics are guaranteed only within the safety maximum ratings which must be ensured by protective circuits in application.

Absolute Maximum Ratings* (No Derating Required up to 85°C)

Parameter	Symbol	Package**	Min.	Max.	Units	Note
Storage Temperature	T _S		-55	125	°C	
Operating Temperature†	T _A		-40	85	°C	
Average Forward Input Current	I _F	Single 8-Pin DIP Single SO-8 Widebody		20	mA	2
		Dual 8-Pin DIP Dual SO-8		15		
Reverse Input Voltage	V _R	8-Pin DIP, SO-8		5	V	1
		Widebody		3		
Input Power Dissipation	P _I	Widebody		40	mW	
Supply Voltage (1 Minute Maximum)	V _{CC}			7	V	
Enable Input Voltage (Not to Exceed V _{CC} by more than 500 mV)	V _E	Single 8-Pin DIP Single SO-8 Widebody		V _{CC} + 0.5	V	
Enable Input Current	I _E			5	mA	
Output Collector Current	I _O			50	mA	1
Output Collector Voltage (Selection for Higher Output Voltages up to 20 V is Available.)	V _O			7	V	1
Output Collector Power Dissipation	P _O	Single 8-Pin DIP Single SO-8 Widebody		85	mW	1, 4
		Dual 8-Pin DIP Dual SO-8		60		
Lead Solder Temperature (Through Hole Parts Only)	T _{LS}	8-Pin DIP	260°C for 10 sec., 1.6 mm below seating plane			
		Widebody	260°C for 10 sec., up to seating plane			
Solder Reflow Temperature Profile (Surface Mount Parts Only)		SO-8 and Option 300	See Package Outline Drawings section			

*JEDEC Registered Data (for 6N137 only).

**Ratings apply to all devices except otherwise noted in the Package column.

†0°C to 70°C on JEDEC Registration.

Recommended Operating Conditions

Parameter	Symbol	Min.	Max.	Units
Input Current, Low Level	I _{FL} *	0	250	µA
Input Current, High Level ^[1]	I _{FH} **	5	15	mA
Power Supply Voltage	V _{CC}	4.5	5.5	V
Low Level Enable Voltage†	V _{EL}	0	0.8	V
High Level Enable Voltage†	V _{EH}	2.0	V _{CC}	V
Operating Temperature	T _A	-40	85	°C
Fan Out (at R _L = 1 kΩ) ^[1]	N		5	TTL Loads
Output Pull-up Resistor	R _L	330	4 k	Ω

*The off condition can also be guaranteed by ensuring that V_{FL} ≤ 0.8 volts.

**The initial switching threshold is 5 mA or less. It is recommended that 6.3 mA to 10 mA be used for best performance and to permit at least a 20% LED degradation guardband.

†For single channel products only.

Electrical Specifications

Over recommended temperature ($T_A = -40^\circ\text{C}$ to $+85^\circ\text{C}$) unless otherwise specified. All Typicals at $V_{CC} = 5\text{ V}$, $T_A = 25^\circ\text{C}$. All enable test conditions apply to single channel products only. See note 5.

Parameter	Sym.	Package	Min.	Typ.	Max.	Units	Test Conditions	Fig.	Note	
High Level Output Current	I_{OH}^*	All		5.5	100	μA	$V_{CC} = 5.5\text{ V}$, $V_E = 2.0\text{ V}$, $V_O = 5.5\text{ V}$, $I_F = 250\ \mu\text{A}$	1	1, 6, 19	
Input Threshold Current	I_{TH}	Single Channel Widebody		2.0	5.0	mA	$V_{CC} = 5.5\text{ V}$, $V_E = 2.0\text{ V}$, $V_O = 0.6\text{ V}$, $I_{OL}(\text{Sinking}) = 13\text{ mA}$	2, 3	19	
		Dual Channel		2.5						
Low Level Output Voltage	V_{OL}^*	8-Pin DIP SO-8		0.35	0.6	V	$V_{CC} = 5.5\text{ V}$, $V_E = 2.0\text{ V}$, $I_F = 5\text{ mA}$, $I_{OL}(\text{Sinking}) = 13\text{ mA}$	2, 3, 4, 5	1, 19	
		Widebody		0.4						
High Level Supply Current	I_{CCH}	Single Channel		7.0	10.0*	mA	$V_F = 0.5\text{ V}$, $V_{CC} = 5.5\text{ V}$, $V_E = V_{CC}$, $I_F = 0\text{ mA}$		7	
		Dual Channel		10	15	Both Channels				
Low Level Supply Current	I_{CCL}	Single Channel		9.0	13.0*	mA	$V_F = 0.5\text{ V}$, $V_{CC} = 5.5\text{ V}$, $V_E = V_{CC}$, $I_F = 10\text{ mA}$		8	
		Dual Channel		13	21	Both Channels				
High Level Enable Current	I_{EH}	Single Channel		-0.7	-1.6	mA	$V_{CC} = 5.5\text{ V}$, $V_E = 2.0\text{ V}$			
Low Level Enable Current	I_{EL}^*			-0.9	-1.6	mA	$V_{CC} = 5.5\text{ V}$, $V_E = 0.5\text{ V}$		9	
High Level Enable Voltage	V_{EH}			2.0		V			19	
Low Level Enable Voltage	V_{EL}				0.8	V				
Input Forward Voltage	V_F	8-Pin DIP SO-8		1.4	1.5	1.75*	$T_A = 25^\circ\text{C}$, $I_F = 10\text{ mA}$	6, 7	1	
				1.3		1.80				
		Widebody		1.25	1.64	1.85				$T_A = 25^\circ\text{C}$
				1.2		2.05				
Input Reverse Breakdown Voltage	BV_R^*	8-Pin DIP SO-8	5			V	$I_R = 10\ \mu\text{A}$		1	
		Widebody	3				$I_R = 100\ \mu\text{A}$, $T_A = 25^\circ\text{C}$			
Input Diode Temperature Coefficient	$\Delta V_F / \Delta T_A$	8-Pin DIP SO-8		-1.6		$\text{mV}/^\circ\text{C}$	$I_F = 10\text{ mA}$	7	1	
		Widebody		-1.9						
Input Capacitance	C_{IN}	8-Pin DIP SO-8		60		pF	$f = 1\text{ MHz}$, $V_F = 0\text{ V}$		1	
		Widebody		70						

*JEDEC registered data for the 6N137. The JEDEC Registration specifies 0°C to $+70^\circ\text{C}$. HP specifies -40°C to $+85^\circ\text{C}$.

Switching Specifications (AC)

Over Recommended Temperature ($T_A = -40^\circ\text{C}$ to $+85^\circ\text{C}$), $V_{CC} = 5\text{ V}$, $I_F = 7.5\text{ mA}$ unless otherwise specified. All Typical at $T_A = 25^\circ\text{C}$, $V_{CC} = 5\text{ V}$.

Parameter	Sym.	Package**	Min.	Typ.	Max.	Units	Test Conditions	Fig.	Note
Propagation Delay Time to High Output Level	t_{PLH}		20	48	75*	ns	$T_A = 25^\circ\text{C}$ $R_L = 350\ \Omega$ $C_L = 15\text{ pF}$	8, 9, 10	1, 10, 19
					100				
Propagation Delay Time to Low Output Level	t_{PHL}		25	50	75*	ns	$T_A = 25^\circ\text{C}$		1, 11, 19
					100				
Pulse Width Distortion	$ t_{PHL} - t_{PLH} $	8-Pin DIP		3.5	35	ns		8, 9, 10, 11	13, 19
		SO-8							
		Widebody			40				
Propagation Delay Skew	t_{PSK}				40	ns			12, 13, 19
Output Rise Time (10-90%)	t_r			24		ns		12	1, 19
Output Fall Time (90-10%)	t_f			10		ns		12	1, 19
Propagation Delay Time of Enable from V_{EH} to V_{EL}	t_{ELH}	Single Channel		30		ns	$R_L = 350\ \Omega$, $C_L = 15\text{ pF}$, $V_{EL} = 0\text{ V}$, $V_{EH} = 3\text{ V}$	13, 14	14
Propagation Delay Time of Enable from V_{EL} to V_{EH}	t_{EHL}	Single Channel		20		ns			15

*JEDEC registered data for the 6N137.

Ratings apply to all devices except otherwise noted in the **Package column.

Parameter	Sym.	Device	Min.	Typ.	Units	Test Conditions	Fig.	Note
Logic High Common Mode Transient Immunity	$ CM_H $	6N137 HCPL-2630 HCPL-0600/0630 HCNW137		10,000	$V_\mu\text{s}$	$ V_{CM} = 10\text{ V}$ $V_{CC} = 5\text{ V}$, $I_F = 0\text{ mA}$, $V_{O(MIN)} = 2\text{ V}$, $R_L = 350\ \Omega$, $T_A = 25^\circ\text{C}$	15	1, 16, 18, 19
		HCPL-2601/2631 HCPL-0601/0631 HCNW2601	5,000	10,000	$ V_{CM} = 50\text{ V}$			
		HCPL-2611/4661 HCPL-0611/0661 HCNW2611	10,000	15,000	$ V_{CM} = 1\text{ kV}$			
Logic Low Common Mode Transient Immunity	$ CM_L $	6N137 HCPL-2630 HCPL-0600/0630 HCNW137		10,000	$V_\mu\text{s}$	$ V_{CM} = 10\text{ V}$ $V_{CC} = 5\text{ V}$, $I_F = 7.5\text{ mA}$, $V_{O(MAX)} = 0.8\text{ V}$, $R_L = 350\ \Omega$, $T_A = 25^\circ\text{C}$	15	1, 17, 18, 19
		HCPL-2601/2631 HCPL-0601/0631 HCNW2601	5,000	10,000	$ V_{CM} = 50\text{ V}$			
		HCPL-2611/4661 HCPL-0611/0661 HCNW2611	10,000	15,000	$ V_{CM} = 1\text{ kV}$			

Package Characteristics

All Typical at $T_A = 25^\circ\text{C}$.

Parameter	Sym.	Package	Min.	Typ.	Max.	Units	Test Conditions	Fig.	Note
Input-Output Insulation	I_{I-O}^*	Single 8-Pin DIP Single SO-8			1	μA	45% RH, $t = 5 \text{ s}$, $V_{I-O} = 3 \text{ kV dc}$, $T_A = 25^\circ\text{C}$		20, 21
Input-Output Momentary Withstand Voltage**	V_{ISO}	8-Pin DIP, SO-8	2500			V rms	RH $\leq 50\%$, $t = 1 \text{ min}$, $T_A = 25^\circ\text{C}$		20, 21
		Widebody	5000						20, 22
		OPT 020†	5000						
Input-Output Resistance	R_{I-O}	8-Pin DIP, SO-8		10^{12}		Ω	$V_{I-O} = 500 \text{ V dc}$		1, 20, 23
		Widebody	10^{12}	10^{13}					
			10^{11}						
Input-Output Capacitance	C_{I-O}	8-Pin DIP, SO-8		0.6		pF	$f = 1 \text{ MHz}$, $T_A = 25^\circ\text{C}$		1, 20, 23
		Widebody		0.5	0.6				
Input-Input Insulation Leakage Current	I_{I-I}	Dual Channel		0.005		μA	RH $\leq 45\%$, $t = 5 \text{ s}$, $V_{I-I} = 500 \text{ V}$		24
Resistance (Input-Input)	R_{I-I}	Dual Channel		10^{11}		Ω			24
Capacitance (Input-Input)	C_{I-I}	Dual 8-Pin DIP		0.03		pF	$f = 1 \text{ MHz}$		24
		Dual SO-8		0.25					

*JEDEC registered data for the 6N137. The JEDEC Registration specifies 0°C to 70°C . HP specifies -40°C to 85°C .

**The Input-Output Momentary Withstand Voltage is a dielectric voltage rating that should not be interpreted as an input-output continuous voltage rating. For the continuous voltage rating refer to the VDE 0884 Insulation Characteristics Table (if applicable), your equipment level safety specification or HP Application Note 1074 entitled "Optocoupler Input-Output Endurance Voltage."

†For 6N137, HCPL-2601/2611/2630/2631/4661 only.

Notes:

- Each channel.
- Peaking circuits may produce transient input currents up to 50 mA, 50 ns maximum pulse width, provided average current does not exceed 20 mA.
- Peaking circuits may produce transient input currents up to 50 mA, 50 ns maximum pulse width, provided average current does not exceed 15 mA.
- Derate linearly above 80°C free-air temperature at a rate of $2.7 \text{ mW}/^\circ\text{C}$ for the SOIC-8 package.
- Bypassing of the power supply line is required, with a $0.1 \mu\text{F}$ ceramic disc capacitor adjacent to each optocoupler as illustrated in Figure 17. Total lead length between both ends of the capacitor and the isolator pins should not exceed 20 mm.
- The JEDEC registration for the 6N137 specifies a maximum I_{OH} of 250 μA . HP guarantees a maximum I_{OH} of 100 μA .
- The JEDEC registration for the 6N137 specifies a maximum I_{CCH} of 15 mA. HP guarantees a maximum I_{CCH} of 10 mA.
- The JEDEC registration for the 6N137 specifies a maximum I_{CCL} of 18 mA. HP guarantees a maximum I_{CCL} of 13 mA.
- The JEDEC registration for the 6N137 specifies a maximum I_{EL} of -2.0 mA . HP guarantees a maximum I_{EL} of -1.6 mA .
- The t_{PLH} propagation delay is measured from the 3.75 mA point on the falling edge of the input pulse to the 1.5 V point on the rising edge of the output pulse.
- The t_{PHL} propagation delay is measured from the 3.75 mA point on the rising edge of the input pulse to the 1.5 V point on the falling edge of the output pulse.
- t_{PSK} is equal to the worst case difference in t_{PHL} and/or t_{PLH} that will be seen between units at any given temperature and specified test conditions.
- See application section titled "Propagation Delay, Pulse-Width Distortion and Propagation Delay Skew" for more information.
- The t_{ELH} enable propagation delay is measured from the 1.5 V point on the falling edge of the enable input pulse to the 1.5 V point on the rising edge of the output pulse.
- The t_{EHL} enable propagation delay is measured from the 1.5 V point on the rising edge of the enable input pulse to the 1.5 V point on the falling edge of the output pulse.
- CM_H is the maximum tolerable rate of rise of the common mode voltage to assure that the output will remain in a high logic state (i.e., $V_O > 2.0 \text{ V}$).
- CM_L is the maximum tolerable rate of fall of the common mode voltage to assure that the output will remain in a low logic state (i.e., $V_O < 0.8 \text{ V}$).
- For sinusoidal voltages, $(|dV_{CM}| / dt)_{\max} = \pi f_{CM} V_{CM}(p-p)$.

19. No external pull up is required for a high logic state on the enable input. If the V_E pin is not used, tying V_E to V_{CC} will result in improved CMR performance. For single channel products only.
20. Device considered a two-terminal device: pins 1, 2, 3, and 4 shorted together, and pins 5, 6, 7, and 8 shorted together.
21. In accordance with UL1577, each optocoupler is proof tested by applying an insulation test voltage ≥ 3000 V rms for one second (leakage detection current limit, $I_{L0} \leq 5 \mu A$). This test is performed before the 100% production test for partial discharge (Method b) shown in the VDE 0884 Insulation Characteristics Table, if applicable.
22. In accordance with UL 1577, each optocoupler is proof tested by applying an insulation test voltage ≥ 6000 V rms for one second (leakage detection current limit, $I_{L0} \leq 5 \mu A$). This test is performed before the 100% production test for partial discharge (Method b) shown in the VDE 0884 Insulation Characteristics Table, if applicable.
23. Measured between the LED anode and cathode shorted together and pins 5 through 8 shorted together. For dual channel products only.
24. Measured between pins 1 and 2 shorted together, and pins 3 and 4 shorted together. For dual channel products only.

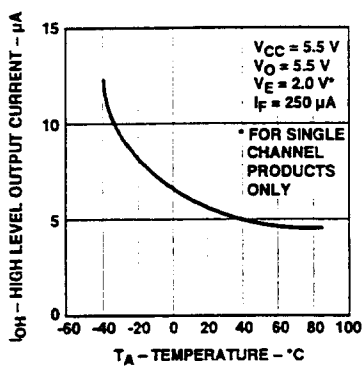

Figure 1. Typical High Level Output Current vs. Temperature.

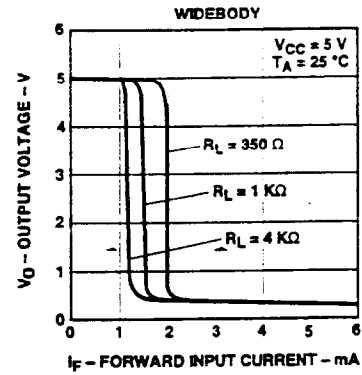
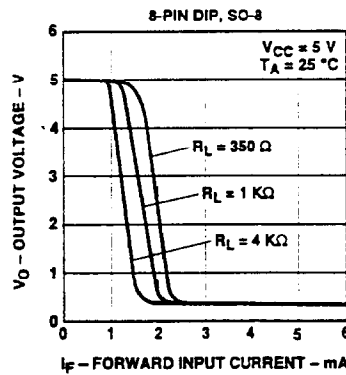

Figure 2. Typical Output Voltage vs. Forward Input Current.

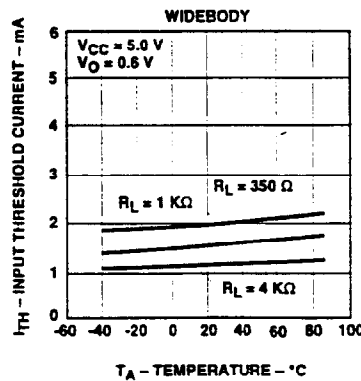
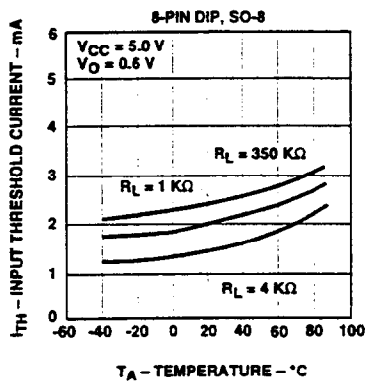

Figure 3. Typical Input Threshold Current vs. Temperature.

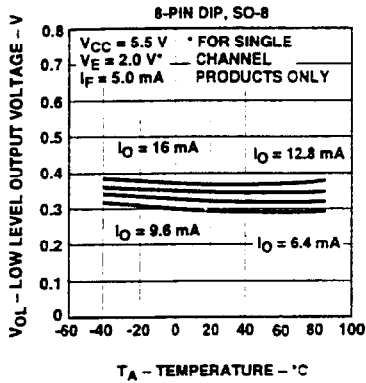

Figure 4. Typical Low Level Output Voltage vs. Temperature.

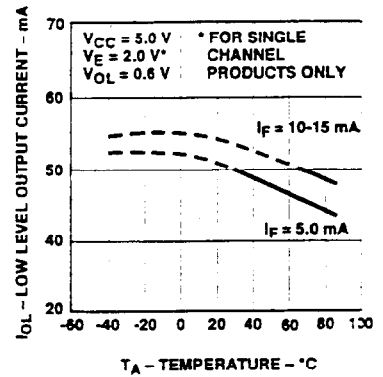
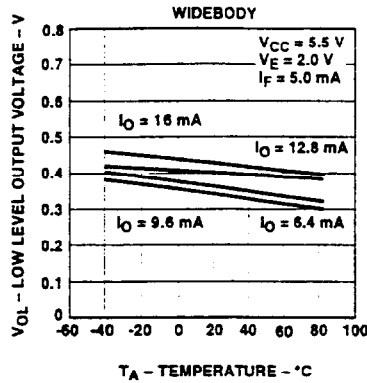

Figure 5. Typical Low Level Output Current vs. Temperature.

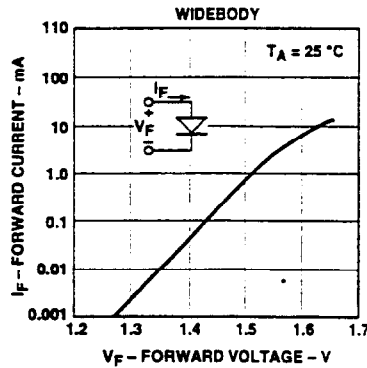
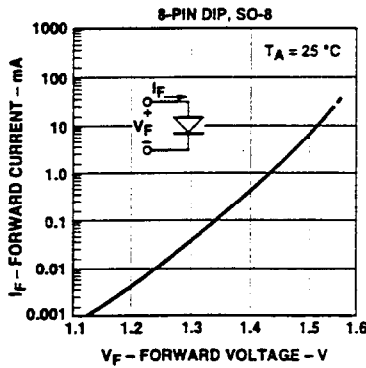

Figure 6. Typical Input Diode Forward Characteristic.

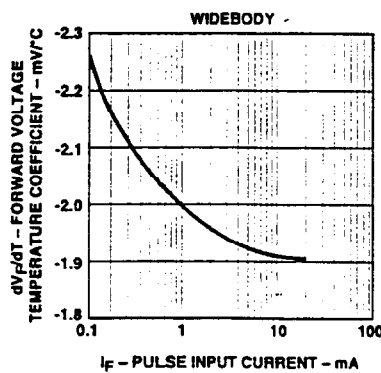
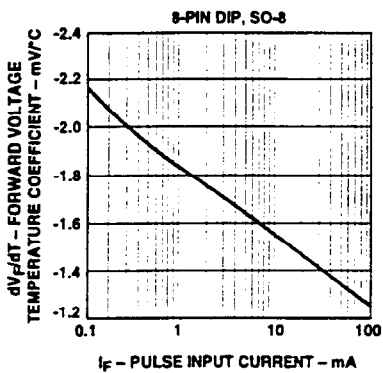
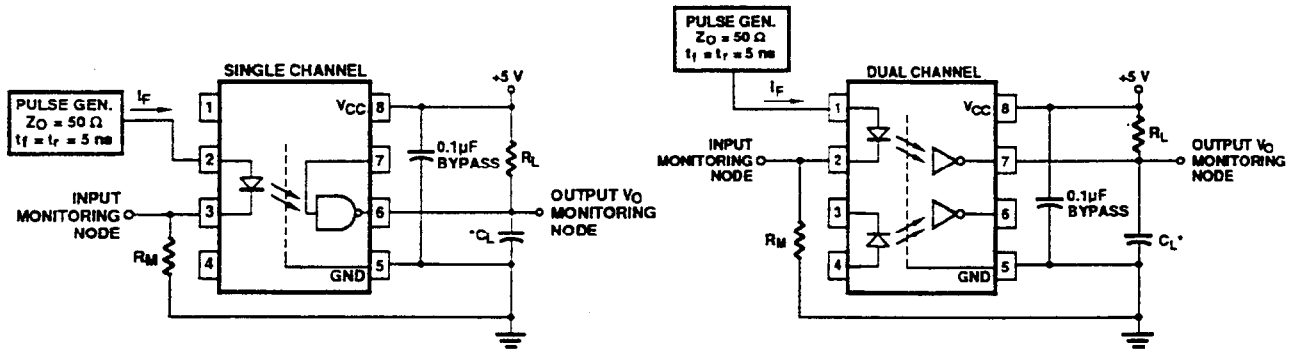

Figure 7. Typical Temperature Coefficient of Forward Voltage vs. Input Current.



*CL IS APPROXIMATELY 15 pF WHICH INCLUDES PROBE AND STRAY WIRING CAPACITANCE.

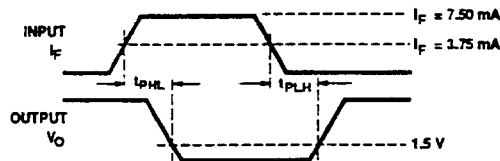

Figure 8. Test Circuit for t_{PHL} and t_{PLH} .

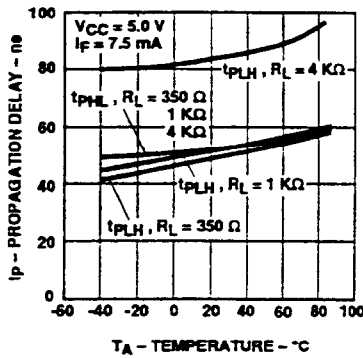

Figure 9. Typical Propagation Delay vs. Temperature.

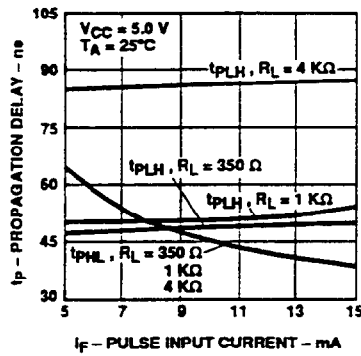

Figure 10. Typical Propagation Delay vs. Pulse Input Current.

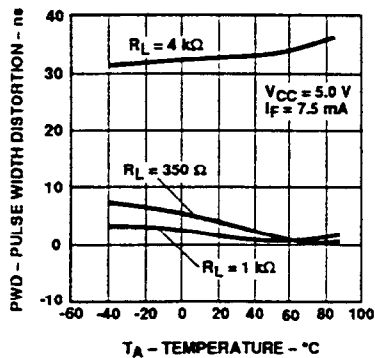

Figure 11. Typical Pulse Width Distortion vs. Temperature.

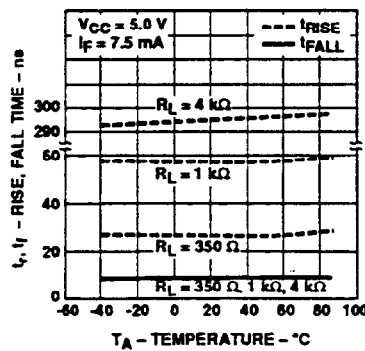

Figure 12. Typical Rise and Fall Time vs. Temperature.

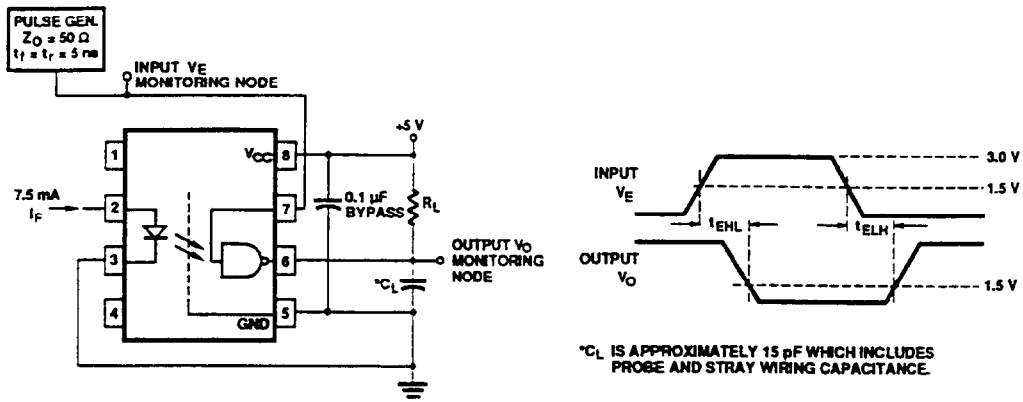

Figure 13. Test Circuit for t_{rHL} and t_{rLH} .

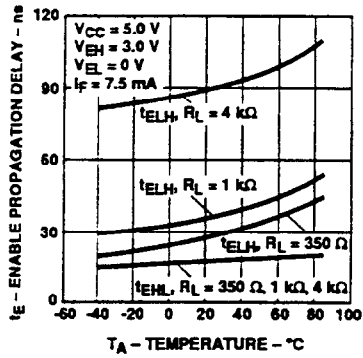

Figure 14. Typical Enable Propagation Delay vs. Temperature.

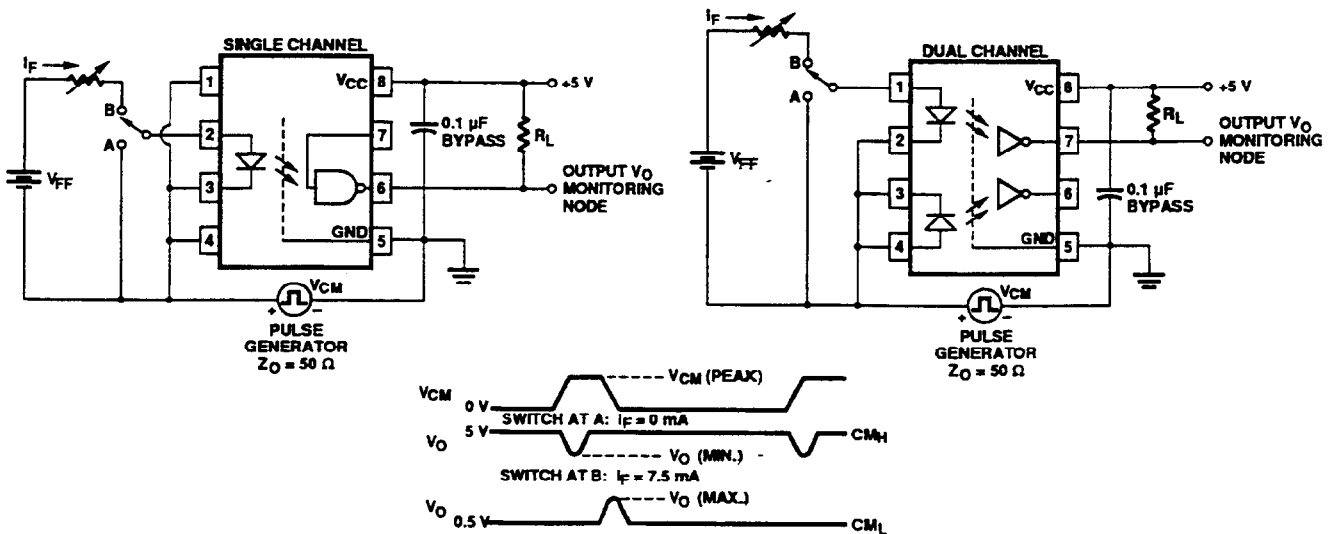

Figure 15. Test Circuit for Common Mode Transient Immunity and Typical Waveforms.

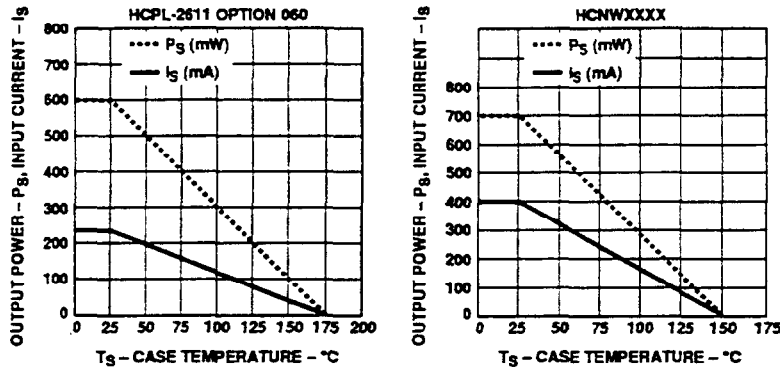

Figure 16. Thermal Derating Curve, Dependence of Safety Limiting Value with Case Temperature per VDE 0884.

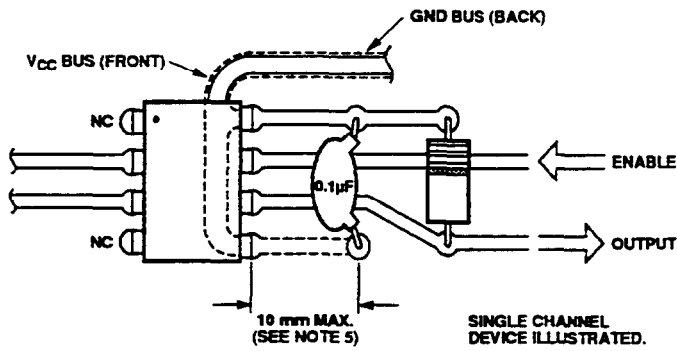
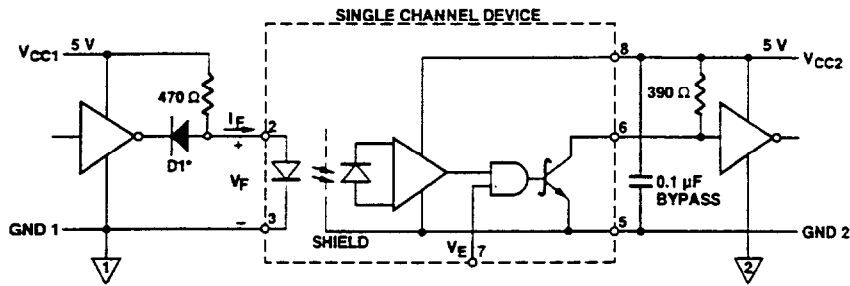

Figure 17. Recommended Printed Circuit Board Layout.



*DIODE D1 (1N916 OR EQUIVALENT) IS NOT REQUIRED FOR UNITS WITH OPEN COLLECTOR OUTPUT.

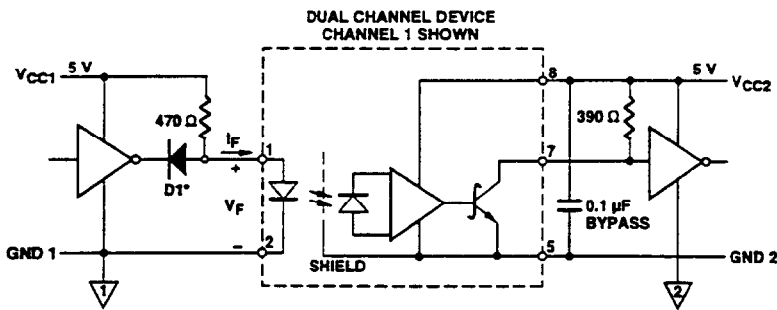

Figure 18. Recommended TTL/LSTTL to TTL/LSTTL Interface Circuit.

Propagation Delay, Pulse-Width Distortion and Propagation Delay Skew

Propagation delay is a figure of merit which describes how quickly a logic signal propagates through a system. The propagation delay from low to high (t_{PLH}) is the amount of time required for an input signal to propagate to the output, causing the output to change from low to high. Similarly, the propagation delay from high to low (t_{PHL}) is the amount of time required for the input signal to propagate to the output causing the output to change from high to low (see Figure 8).

Pulse-width distortion (PWD) results when t_{PLH} and t_{PHL} differ in value. PWD is defined as the difference between t_{PLH} and t_{PHL} and often determines the maximum data rate capability of a transmission system. PWD can be expressed in percent by dividing the PWD (in ns) by the minimum pulse width (in ns) being transmitted. Typically, PWD on the order of 20-30% of the minimum pulse width is tolerable; the exact figure depends on the particular application (RS232, RS422, T-1, etc.).

Propagation delay skew, t_{PSK} , is an important parameter to consider in parallel data applica-

tions where synchronization of signals on parallel data lines is a concern. If the parallel data is being sent through a group of optocouplers, differences in propagation delays will cause the data to arrive at the outputs of the optocouplers at different times. If this difference in propagation delays is large enough, it will determine the maximum rate at which parallel data can be sent through the optocouplers.

Propagation delay skew is defined as the difference between the minimum and maximum propagation delays, either t_{PLH} or t_{PHL} , for any given group of optocouplers which are operating under the same conditions (i.e., the same drive current, supply voltage, output load, and operating temperature). As illustrated in Figure 19, if the inputs of a group of optocouplers are switched either ON or OFF at the same time, t_{PSK} is the difference between the shortest propagation delay, either t_{PLH} or t_{PHL} , and the longest propagation delay, either t_{PLH} or t_{PHL} .

As mentioned earlier, t_{PSK} can determine the maximum parallel data transmission rate. Figure 20 is the timing diagram of a typical parallel data application with both the clock and the data lines being sent through optocouplers. The figure shows data and clock

signals at the inputs and outputs of the optocouplers. To obtain the maximum data transmission rate, both edges of the clock signal are being used to clock the data; if only one edge were used, the clock signal would need to be twice as fast.

Propagation delay skew represents the uncertainty of where an edge might be after being sent through an optocoupler. Figure 20 shows that there will be uncertainty in both the data and the clock lines. It is important that these two areas of uncertainty not overlap, otherwise the clock signal might arrive before all of the data outputs have settled, or some of the data outputs may start to change before the clock signal has arrived. From these considerations, the absolute minimum pulse width that can be sent through optocouplers in a parallel application is twice t_{PSK} . A cautious design should use a slightly longer pulse width to ensure that any additional uncertainty in the rest of the circuit does not cause a problem.

The t_{PSK} specified optocouplers offer the advantages of guaranteed specifications for propagation delays, pulsewidth distortion and propagation delay skew over the recommended temperature, input current, and power supply ranges.

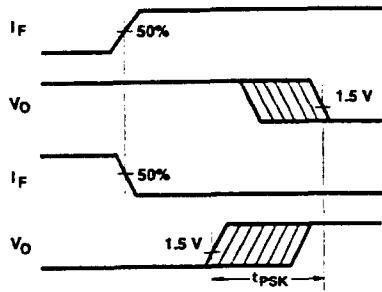

Figure 19. Illustration of Propagation Delay Skew - t_{PSK} .

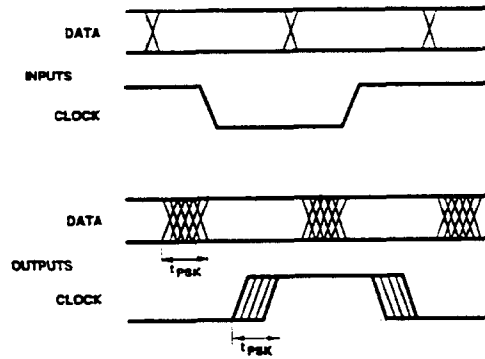

Figure 20. Parallel Data Transmission Example.

Appendix B

Motorola Array Technical Data*

This appendix contains technical data on the Motorola Corporation ULN2801 array. Motorola arrays are used on the SC-206X.

* Copyright © Motorola Corporation, 1990. Reprinted with permission of copyright owner. All rights reserved. Motorola Corporation. 1990 *Linear and Interface integrated Circuits*.

MOTOROLA
SEMICONDUCTOR
TECHNICAL DATA

**OCTAL HIGH VOLTAGE, HIGH CURRENT
 DARLINGTON TRANSISTOR ARRAYS**

The eight NPN Darlington connected transistors in this family of arrays are ideally suited for interfacing between low logic level digital circuitry (such as TTL, CMOS or PMOS/NMOS) and the higher current/voltage requirements of lamps, relays, printer hammers or other similar loads for a broad range of computer, industrial, and consumer applications. All devices feature open-collector outputs and free wheeling clamp diodes for transient suppression.

The ULN2801 is a general purpose device for use with CMOS, PMOS or TTL logic. The ULN2802 contains a zener diode and resistor in series with the input to limit input currents and assure compatibility with 14 to 25 volt PMOS logic. The ULN2803 is designed to be compatible with standard TTL families while the ULN2804 is optimized for 6 to 15 volt high level CMOS or PMOS.

ULN2801
ULN2802
ULN2803
ULN2804

**OCTAL
 PERIPHERAL
 DRIVER ARRAYS**

**SILICON MONOLITHIC
 INTEGRATED CIRCUITS**

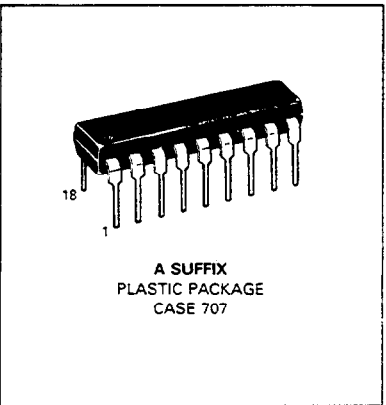

7

MAXIMUM RATINGS ($T_A = 25^\circ\text{C}$ and rating apply to any one device in the package unless otherwise noted.)

Rating	Symbol	Value	Unit
Output Voltage	V_O	50	V
Input Voltage (Except ULN2801)	V_I	30	V
Collector Current — Continuous	I_C	500	mA
Base Current — Continuous	I_B	25	mA
Operating Ambient Temperature Range	T_A	0 to +70	$^\circ\text{C}$
Storage Temperature Range	T_{stg}	-55 to +150	$^\circ\text{C}$
Junction Temperature	T_J	125	$^\circ\text{C}$

$R_{\theta JA} = 55^\circ\text{C/W}$
 Do not exceed maximum current limit per driver.

ORDERING INFORMATION

Device	Characteristics		
	Input Compatibility	$V_{CE}(\text{Max})/I_C(\text{Max})$	T_A
ULN2801A	General Purpose CMOS, PMOS	50 V/500 mA	0 to +70 $^\circ\text{C}$
ULN2802A	14-25 Volt PMOS		
ULN2803A	TTL, 5.0 V CMOS		
ULN2804A	6-15 V CMOS, PMOS		

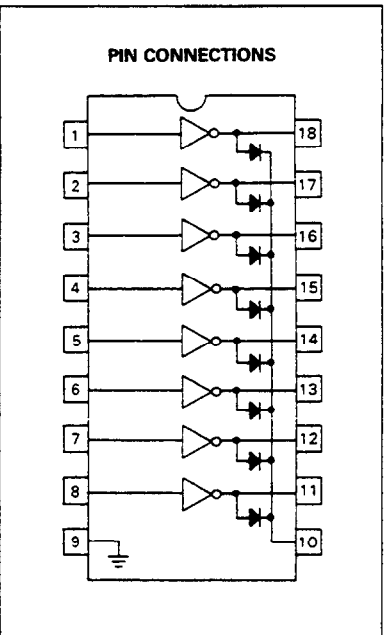

MOTOROLA LINEAR/INTERFACE DEVICES

7-201

ELECTRICAL CHARACTERISTICS ($T_A = 25^\circ\text{C}$ unless otherwise noted)

Characteristic		Fig.	Symbol	Min	Typ	Max	Unit
Output Leakage Current ($V_O = 50\text{ V}$, $T_A = +70^\circ\text{C}$) ($V_O = 50\text{ V}$, $T_A = +25^\circ\text{C}$) ($V_O = 50\text{ V}$, $T_A = +70^\circ\text{C}$, $V_I = 6.0\text{ V}$) ($V_O = 50\text{ V}$, $T_A = +70^\circ\text{C}$, $V_I = 1.0\text{ V}$)	All Types All Types ULN2802 ULN2804	1	I_{CEX}	— — — —	— — — —	100 50 500 500	μA
Collector-Emitter Saturation Voltage ($I_C = 350\text{ mA}$, $I_B = 500\text{ }\mu\text{A}$) ($I_C = 200\text{ mA}$, $I_B = 350\text{ }\mu\text{A}$) ($I_C = 100\text{ mA}$, $I_B = 250\text{ }\mu\text{A}$)	All Types All Types All Types	2	$V_{CE(sat)}$	— — —	1.1 0.95 0.85	1.6 1.3 1.1	V
Input Current — On Condition ($V_I = 17\text{ V}$) ($V_I = 3.85\text{ V}$) ($V_I = 5.0\text{ V}$) ($V_I = 12\text{ V}$)	ULN2802 ULN2803 ULN2804 ULN2804	4	$I_{I(on)}$	— — — —	0.82 0.93 0.35 1.0	1.25 1.35 0.5 1.45	mA
Input Voltage — On Condition ($V_{CE} = 2.0\text{ V}$, $I_C = 300\text{ mA}$) ($V_{CE} = 2.0\text{ V}$, $I_C = 200\text{ mA}$) ($V_{CE} = 2.0\text{ V}$, $I_C = 250\text{ mA}$) ($V_{CE} = 2.0\text{ V}$, $I_C = 300\text{ mA}$) ($V_{CE} = 2.0\text{ V}$, $I_C = 125\text{ mA}$) ($V_{CE} = 2.0\text{ V}$, $I_C = 200\text{ mA}$) ($V_{CE} = 2.0\text{ V}$, $I_C = 275\text{ mA}$) ($V_{CE} = 2.0\text{ V}$, $I_C = 350\text{ mA}$)	ULN2802 ULN2803 ULN2803 ULN2803 ULN2804 ULN2804 ULN2804 ULN2804	5	$V_{I(on)}$	— — — — — — — —	— — — — — — — —	13 2.4 2.7 3.0 5.0 6.0 7.0 8.0	V
Input Current — Off Condition ($I_C = 500\text{ }\mu\text{A}$, $T_A = +70^\circ\text{C}$)	All Types	3	$I_{I(off)}$	50	100	—	μA
DC Current Gain ($V_{CE} = 2.0\text{ V}$, $I_C = 350\text{ mA}$)	ULN2801	2	h_{FE}	1000	—	—	—
Input Capacitance			C_I	—	15	25	pF
Turn-On Delay Time (50% E_I to 50% E_O)			t_{on}	—	0.25	1.0	μs
Turn-Off Delay Time (50% E_I to 50% E_O)			t_{off}	—	0.25	1.0	μs
Clamp Diode Leakage Current ($V_R = 50\text{ V}$)	$T_A = +25^\circ\text{C}$ $T_A = +70^\circ\text{C}$	6	I_R	—	—	50 100	μA
Clamp Diode Forward Voltage ($I_F = 350\text{ mA}$)		7	V_F	—	1.5	2.0	V

7

ULN2801, ULN2802, ULN2803, ULN2804

TEST FIGURES

(SEE FIGURE NUMBERS IN ELECTRICAL CHARACTERISTICS TABLES)

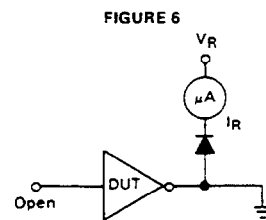
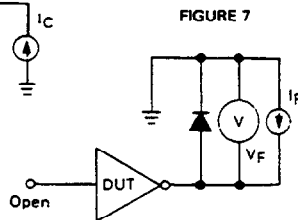
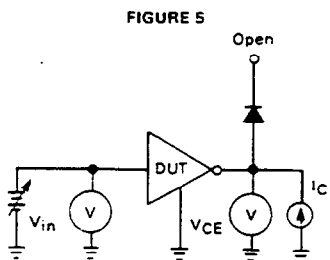
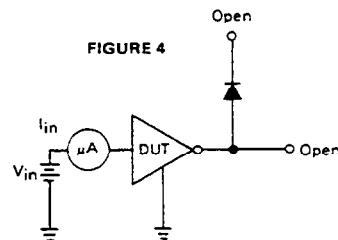
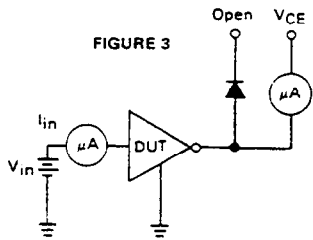
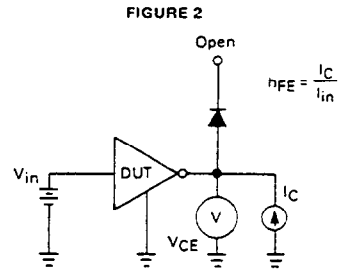
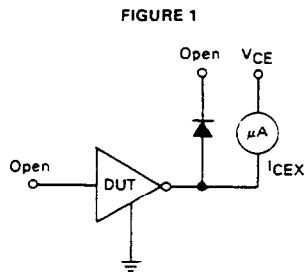

7

ULN2801, ULN2802, ULN2803, ULN2804

TYPICAL CHARACTERISTIC CURVES — $T_A = 25^\circ\text{C}$
(unless otherwise noted)

OUTPUT CHARACTERISTICS

FIGURE 8 — OUTPUT CURRENT versus SATURATION VOLTAGE

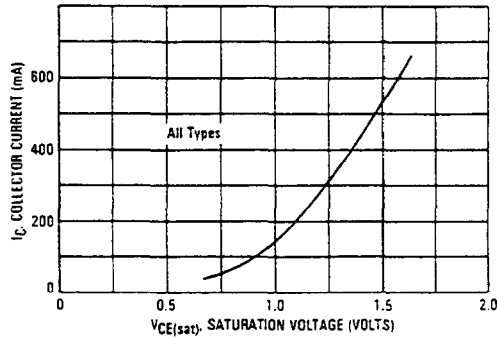
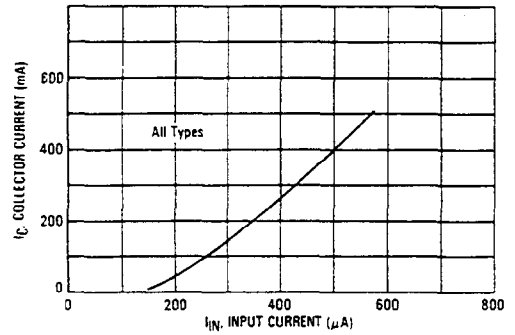

FIGURE 9 — OUTPUT CURRENT versus INPUT CURRENT



INPUT CHARACTERISTICS

FIGURE 10 — ULN2802 INPUT CURRENT versus INPUT VOLTAGE

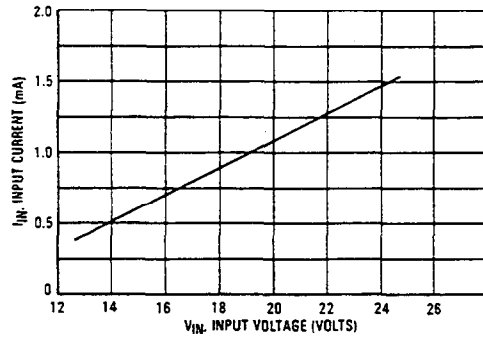

FIGURE 11 — ULN2803 INPUT CURRENT versus INPUT VOLTAGE

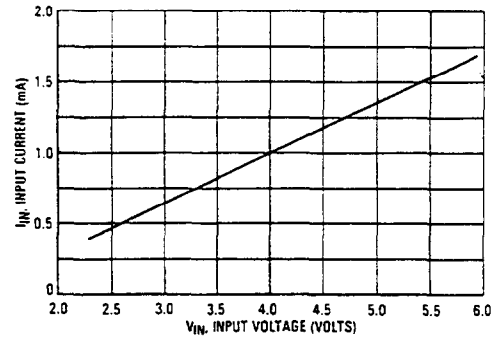
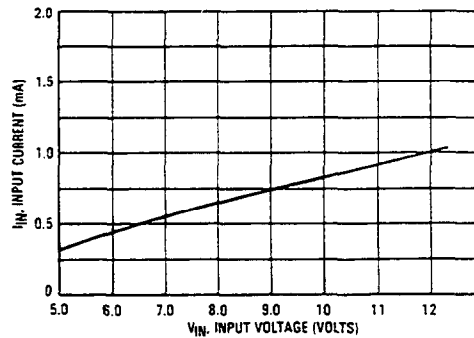

FIGURE 12 — ULN2804 INPUT CURRENT versus INPUT VOLTAGE



7

ULN2801, ULN2802, ULN2803, ULN2804

REPRESENTATIVE CIRCUIT SCHEMATICS

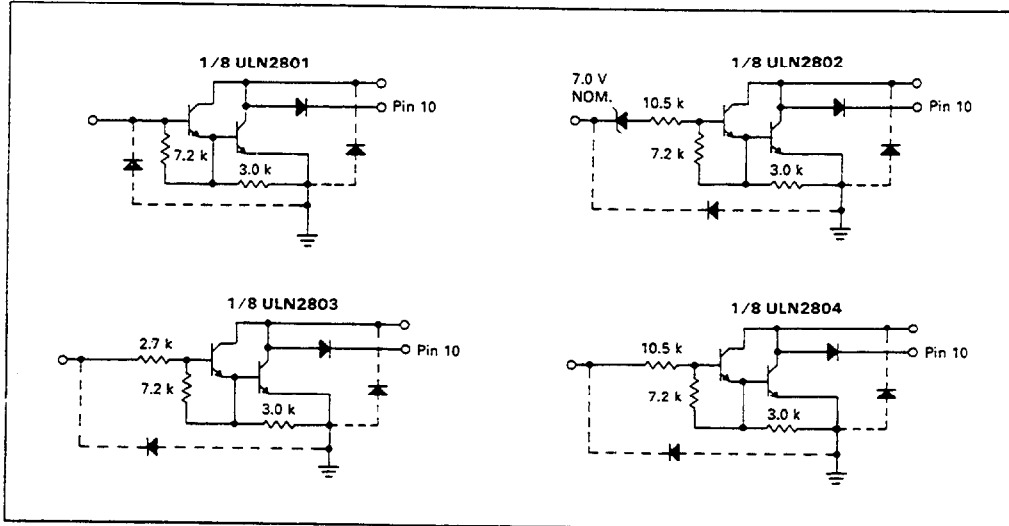

7

Appendix C

American Zettler Relay Technical Data*

This appendix contains technical data on an American Zettler Corporation relay. American Zettler relays are used on the SC-2062.

* Copyright © American Zettler Corporation, 1992-93. Reprinted with permission of copyright owner. All rights reserved. American Zettler Corporation, 1992-93 *Relay Technical Data Book*.

AZ 8

MINIATURE PC BOARD RELAY

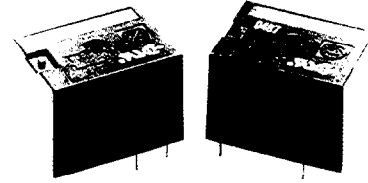

FEATURES

- Subminiature Size
- High Sensitivity, 110 mW Pick Up
- Coils to 48 VDC
- Epoxy Sealed for Automatic Wave Soldering
- Contacts Rated at 3, 6 or 10 Amps
- Life Expectancy to 20 Million Operations
- Extremely Low Cost
- Class B Insulation (130°C) Standard
- Class F Insulation (155°C) Version Available
- UL, CUR File E44211
- VDE Approved Versions Available

CONTACTS

Arrangement	SPDT (1 Form C) 3 or 6 A Version SPST (1 Form A) 10 A Version
Rating	Noninductive load
Light Duty	Max. switched power: 100 W or 600 VA Max. switched current: 3 Amps Max. switched voltage 150* VDC or 300 VAC UL Rating: 2 A @ 28 VDC or 300 VAC 1/8 HP @ 120 VAC 1/10 HP @ 120/240 VAC (100,000 cyc) 1.2/0.6 A @ 120/240 VAC, Pilot Duty 100,000 cyc 3.0/1.5 A @ 120/240 VAC General Use 100,000 cyc
Medium Duty	Max. switched power: 180 W or 1800 VA Max. switched current: 6 Amps Max. switched voltage: 150* VDC or 300 VAC UL Rating: 6 A @ 28 VDC or 300 VAC 1/8 HP @ 120/240 VAC (100,000 cyc) 1.5/0.8 A @ 120/240 VAC, Pilot Duty 100,000 cyc 3.8/1.9 A @ 120/240 VAC General Use 100,000 cyc
Heavy Duty	Max. switched power: 300 W or 2400 VA Max. switched current: 10 Amps Max. switched voltage: 150* VDC or 300 VAC UL Rating: 10 A @ 30 VDC or 120 VAC 1/4 HP @ 120 VAC 1/2 HP @ 250 VAC *Note: If switching voltage is greater than 30 VDC special precautions must be taken. Please contact the factory.
Material	Light Duty: Silver Medium Duty: Silver nickel Heavy Duty: Silver cadmium oxide
Resistance	100 milliohms initially

NOTES

1. All values at 20°C(68°F).
2. Relay may pull in with less than "Must Operate" value.
3. Other coil resistances and sensitivities available upon request.
4. Unsealed relays should not be dip cleaned.
5. Specifications subject to change without notice.

COIL

Power	
At Pick Up Voltage (typical)	Standard coil: 210 mW Sensitive coil: 140 mW Heavy duty: 228 mW (110 mW available)
Max. Continuous Dissipation	Class B: 2.0 W @ 20°C (68°F) ambient 1.6 W @ 40°C (104°F) ambient Class F: 2.5 W @ 20°C (68°F) ambient 2.1 W @ 40°C (104°F) ambient
Temperature Rise	At nominal coil voltage Standard coil: 38°C (68°F) Sensitive coil: 28°C (50°F)
Temperature	Max. 130°C (266°F) Class B Max. 155°C (311°F) Class F

GENERAL DATA

Life Expectancy	Minimum operations 100 million operations
Mechanical	
Electrical	
Light Duty	3x10 ⁵ @ 3 A, 120 VAC
Medium Duty	1.8x10 ⁵ @ 6 A, 120 VAC
Heavy Duty	1x10 ⁵ @ 10 A, 120 VAC
Operate Time (typical)	5 ms at nominal coil voltage
Release Time (typical)	2 ms at nominal coil voltage (with no coil suppression)
Dielectric Strength (at sea level)	750 Vrms contact to contact 3000 Vrms contact to coil VDE 2000 Vrms contact to coil standard
Insulation Resistance	1000 megohms min. @ 20°C, 500 VDC, 50% RH
Drop Out	Greater than 5% of nominal coil voltage
Ambient Temperature Operating	At nominal coil voltage -55°C (-67°F) to 90°C (194°F) Class B -55°C (-67°F) to 115°C (239°F) Class F
Storage	-55°C (-67°F) to 130°C (266°F) Class B -55°C (-67°F) to 155°C (311°F) Class F
Vibration	0.062" DA, 5-55 Hz, 10g at 55-110 Hz
Shock	10 g
Enclosure	P.E.T. polyester
Terminals	Tinned copper alloy, P.C.
Max. Solder Temp.	270°C (518°F)
Max. Solder Time	5 seconds
Max. Solvent Temp.	80°C (176°F)
Max. Immersion Time	30 seconds
Weight	8 grams



AMERICAN ZETTLER, INC.

75 COLUMBIA ARLISO WELLS CA 92656 PHONE (714) 963-5999 FAX (714) 963-6002



RELAY ORDERING DATA

COIL SPECIFICATIONS				ORDER NUMBER			
STANDARD RELAYS: 1 Form C (SPDT)				LIGHT DUTY (3 AMP CONTACT)		MEDIUM DUTY (6 AMP CONTACT)	
Nominal Coil VDC	Max. VDC Continuous	Resistance ± 10%	Must Operate VDC	Unsealed	Epoxy Sealed	Unsealed	Epoxy Sealed
5	10.6	56	3.25	AZ 8-1C-5D	AZ 8-1C-5DE	AZ 8-1CH-5D	AZ 8-1CH-5DE
6	12.6	80	3.90	AZ 8-1C-6D	AZ 8-1C-6DE	AZ 8-1CH-6D	AZ 8-1CH-6DE
9	19.0	180	5.85	AZ 8-1C-9D	AZ 8-1C-9DE	AZ 8-1CH-9D	AZ 8-1CH-9DE
12	25.0	320	7.80	AZ 8-1C-12D	AZ 8-1C-12DE	AZ 8-1CH-12D	AZ 8-1CH-12DE
24	50.0	1280	15.60	AZ 8-1C-24D	AZ 8-1C-24DE	AZ 8-1CH-24D	AZ 8-1CH-24DE
48	87.0	3800	28.80	AZ 8-1C-48D	AZ 8-1C-48DE	AZ 8-1CH-48D	AZ 8-1CH-48DE
SENSITIVE RELAYS: 1 Form C (SPDT)				LIGHT DUTY (3 AMP CONTACT)		MEDIUM DUTY (6 AMP CONTACT)	
Nominal Coil VDC	Max. VDC Continuous	Resistance ± 10%	Must Operate VDC	Unsealed	Epoxy Sealed	Unsealed	Epoxy Sealed
5	12.6	80	3.25	AZ 8-1C-5DS	AZ 8-1C-5DSE	AZ 8-1CH-5DS	AZ 8-1CH-5DSE
6	14.8	110	3.90	AZ 8-1C-6DS	AZ 8-1C-6DSE	AZ 8-1CH-6DS	AZ 8-1CH-6DSE
9	22.4	250	5.85	AZ 8-1C-9DS	AZ 8-1C-9DSE	AZ 8-1CH-9DS	AZ 8-1CH-9DSE
12	30.0	440	7.80	AZ 8-1C-12DS	AZ 8-1C-12DSE	AZ 8-1CH-12DS	AZ 8-1CH-12DSE
24	60.0	1780	15.60	AZ 8-1C-24DS	AZ 8-1C-24DSE	AZ 8-1CH-24DS	AZ 8-1CH-24DSE
STANDARD RELAYS: 1 FORM A (SPST-NO)				HEAVY DUTY (10 AMP CONTACT)			
Nominal Coil VDC	Max. VDC Continuous	Resistance ± 10%	Must Operate VDC	Unsealed		Epoxy Sealed	
5	10.6	56	4.0	AZ 8-1AT-5D		AZ 8-1AT-5DE	
6	12.6	80	4.8	AZ 8-1AT-6D		AZ 8-1AT-6DE	
9	19.0	180	7.2	AZ 8-1AT-9D		AZ 8-1AT-9DE	
12	25.0	320	9.6	AZ 8-1AT-12D		AZ 8-1AT-12DE	
24	50.0	1280	19.2	AZ 8-1AT-24D		AZ 8-1AT-24DE	
48	87.0	3800	38.4	AZ 8-1AT-48D		AZ 8-1AT-48DE	

To indicate Class F version, add suffix "F". Other coil resistances and sensitivities available. Please contact the factory.

MECHANICAL DATA

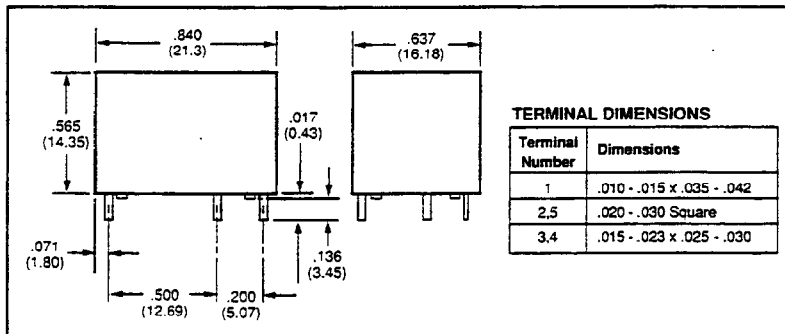

Coil Temperature Rise

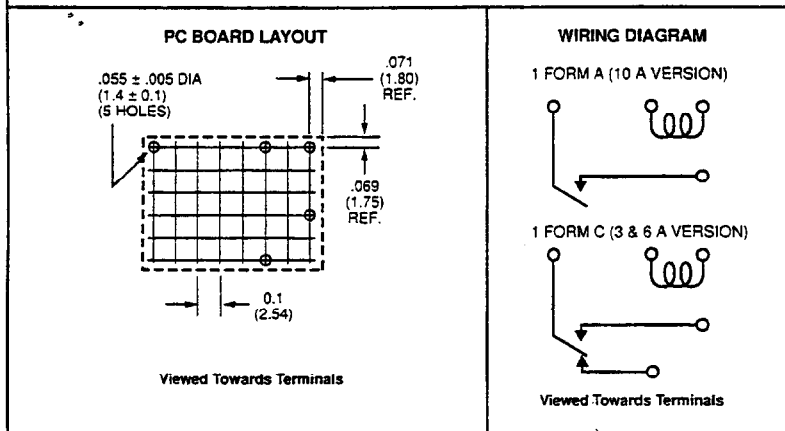
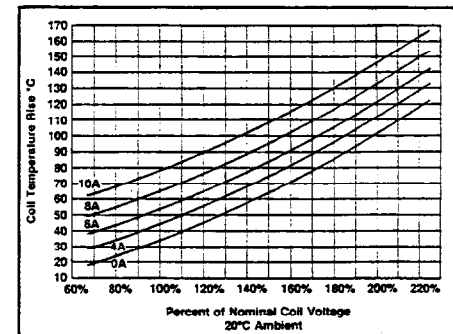

Maximum Switching Capacity

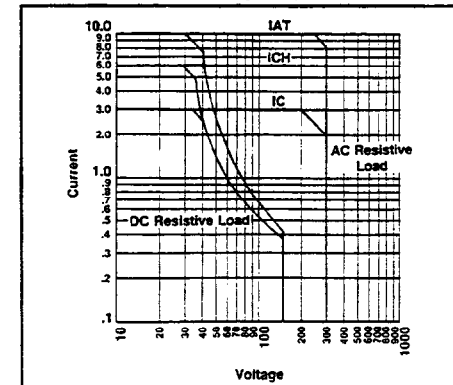

Dimensions in inches with metric equivalents in parentheses. Tolerance: ± .010"



Appendix D

Customer Communication

For your convenience, this appendix contains forms to help you gather the information necessary to help us solve technical problems you might have as well as a form you can use to comment on the product documentation. Filling out a copy of the *Technical Support Form* before contacting National Instruments helps us help you better and faster.

National Instruments provides comprehensive technical assistance around the world. In the U.S. and Canada, applications engineers are available Monday through Friday from 8:00 a.m. to 6:00 p.m. (central time). In other countries, contact the nearest branch office. You may fax questions to us at any time.

Corporate Headquarters

(512) 795-8248

Technical support fax: (800) 328-2203
(512) 794-5678

Branch Offices	Phone Number	Fax Number
Australia	03 9879 5166	03 9879 6277
Austria	0662 45 79 90 0	0662 45 79 90 19
Belgium	02 757 00 20	02 757 03 11
Canada (Ontario)	905 785 0085	905 785 0086
Canada (Quebec)	514 694 8521	514 694 4399
Denmark	45 76 26 00	45 76 26 02
Finland	09 527 2321	09 502 2930
France	01 48 14 24 24	01 48 14 24 14
Germany	089 741 31 30	089 714 60 35
Hong Kong	2645 3186	2686 8505
Israel	03 5734815	03 5734816
Italy	02 413091	02 41309215
Japan	03 5472 2970	03 5472 2977
Korea	02 596 7456	02 596 7455
Mexico	5 520 2635	5 520 3282
Netherlands	0348 433466	0348 430673
Norway	32 84 84 00	32 84 86 00
Singapore	2265886	2265887
Spain	91 640 0085	91 640 0533
Sweden	08 730 49 70	08 730 43 70
Switzerland	056 200 51 51	056 200 51 55
Taiwan	02 377 1200	02 737 4644
U.K.	01635 523545	01635 523154

Technical Support Form

Photocopy this form and update it each time you make changes to your software or hardware, and use the completed copy of this form as a reference for your current configuration. Completing this form accurately before contacting National Instruments for technical support helps our applications engineers answer your questions more efficiently.

If you are using any National Instruments hardware or software products related to this problem, include the configuration forms from their user manuals. Include additional pages if necessary.

Name _____

Company _____

Address _____

Fax (____) _____ Phone (____) _____

Computer brand _____ Model _____ Processor _____

Operating system _____

Speed _____MHz RAM _____MB Display adapter _____

Mouse _____yes _____no Other adapters installed _____

Hard disk capacity _____MB Brand _____

Instruments used _____

National Instruments hardware product model _____ Revision _____

Configuration _____

National Instruments software product _____ Version _____

Configuration _____

The problem is _____

List any error messages _____

The following steps will reproduce the problem _____

SC-206X Hardware and Software Configuration Form

Record the settings and revisions of your hardware and software on the line to the right of each item. Complete a new copy of this form each time you revise your software or hardware configuration, and use this form as a reference for your current configuration. Completing this form accurately before contacting National Instruments for technical support helps our applications engineers answer your questions more efficiently.

National Instruments Products

- Data Acquisition Hardware _____
- Interrupt Level of Hardware _____
- DMA Channels of Hardware _____
- Base I/O Address of Hardware _____
- NI-DAQ Version _____

Other Products

- Computer Make and Model _____
- Microprocessor _____
- Clock Frequency _____
- Type of Video Board Installed _____
- Operating System Version _____
- Operating System Mode _____
- Programming Language _____
- Programming Language Version _____
- Other Boards in System _____
- Base I/O Address of Other Boards _____
- DMA Channels of Other Boards _____
- Interrupt Level of Other Boards _____

Documentation Comment Form

National Instruments encourages you to comment on the documentation supplied with our products. This information helps us provide quality products to meet your needs.

Title: **SC-206X Series User Manual**

Edition Date: **December 1996**

Part Number: **371167A-01**

Please comment on the completeness, clarity, and organization of the manual.

If you find errors in the manual, please record the page numbers and describe the errors.

Thank you for your help.

Name _____

Title _____

Company _____

Address _____

Phone (_____) _____

Mail to: Technical Publications
National Instruments Corporation
6504 Bridge Point Parkway, MS 53-02
Austin, TX 78730-5039

Fax to: Technical Publications
National Instruments Corporation
(512) 794-5678

Glossary

Prefix	Meaning	Value
n-	nano-	10 ⁻⁹
μ-	micro-	10 ⁻⁶
m-	milli-	10 ⁻³
k-	kilo-	10 ³
M-	mega-	10 ⁶

+5V	power supply
°	degrees
Ω	ohms
%	percent
A	amperes
C	Celsius
CMOS	complementary metallic oxide semiconductor
COM	common
GND	ground
Hz	hertz
I _{IL}	current, input low
I _{in}	input current
in.	inches
I/O	input/output
LED	light-emitting diode
m	meters
MB	megabytes
NC	normally closed
NO	normally open
R	resistance
s	seconds
SPDT	single-pole dual-throw
t _{PHL}	propagation delay, high-to-low
t _{PLH}	propagation delay, low-to-high
TTL	transistor-transistor logic
V	volts
VA	volt-ampere
VAC	volts alternating current
V _{cc}	positive voltage supply
VDC	volts direct current
V _{in}	volts in
V _{rms}	volts, root mean square
W	watts

Index

Numbers

+5 V signal, 5-7
26-pin connector. *See* connector J1.

A

American Zettler relays, C-1 to C-3

C

COM connection, SC-2062 board, 4-1, 4-2
computers supported by SC-206X Series boards
 data acquisition boards for SC-206X Series boards (table), 1-1
 SC-2060 board, 2-1
 SC-2061 board, 3-1
 SC-2062 board, 4-1
connecting or disconnecting signal lines
 SC-2060 board, 2-3
 SC-2061 board, 3-2
 SC-2062 board, 4-2
connector J1, 5-7 to 5-8
 damage caused by incorrect connection, 5-7
 pinout (illustration), 5-7
 SC-2060 board, 2-2
 SC-2061 board, 3-1 to 3-2
 SC-2062 board, 4-2
 signal descriptions, 5-7
connectors for SC-205X Series cable adapter boards (table), 5-8
customer communication, *xi*, D-1

D

damage resulting from incorrect signal connections
 connector J1, 5-7
 SC-2060 board, 2-3
 SC-2061 board, 3-2
 SC-2062 board, 4-2
data acquisition boards

 connection to SC-206X Series boards
 SC-2060 board, 2-4
 SC-2061 board, 3-4
 SC-2062 board, 4-4 to 4-5
 via SC-205X Series cable adapter board, 1-1, 5-5 to 5-8
 for use with SC-206X Series boards (table), 1-1
 illustration, 1-2, 5-6
 power supplied by data acquisition boards (table), 5-4
digital input circuitry, SC-2060 board
 description, 2-2
 specifications for optically isolated digital input, 2-3
digital output circuitry, SC-2061 board, 3-3
digital port operation of SC-206X Series boards, 5-8 to 5-9
DIO<0..7> signal, 5-7
documentation
 conventions used, *x*
 organization of manual, *ix*
 related documentation, *x-xi*
double-height mounting of SC-206X Series boards, 5-2 to 5-3

E

electromechanical relay digital output specifications, SC-2062 board, 4-3
equipment, optional, 1-4
external power supply selection. *See* internal or external power selection.

G

GND signal, 5-7
grounding of mounting for SC-206X Series boards, 5-2

H

hardware installation. *See* installation.
HCPL-2611-060 optocoupler, A-1 to A-21

I

IBM PC compatible computers. *See* computers supported by SC-206X Series boards.

input screw terminals, SC-2060 board, 2-1

installation, 5-1 to 5-10

- internal or external power selection, 5-4 to 5-5
- operation of SC-206X Series boards, 5-8 to 5-9
- procedure for installation, 5-1 to 5-3
- safety information, 5-9 to 5-10
- SC-206X Series boards connection via SC-205X Series boards, 5-5 to 5-8
- unpacking, 1-4

internal or external power selection, 5-4 to 5-5

- location of external power screw terminals (illustration), 5-5
- power requirements, 5-4
- power selection settings for switch S1 (illustration), 5-5
- power supplied by data acquisition boards (table), 5-4
- SC-2060 board, 2-2
- SC-2061 board, 3-1 to 3-2
- SC-2062 board, 4-2
- switch S1, 5-4, 5-5

J

J1 connector. *See* connector J1.

M

Macintosh computers. *See* computers supported by SC-206X Series boards.

manual. *See* documentation.

Motorola ULN2801 array. *See* ULN2801 array.

mounting of SC-206X Series boards

- alternative methods, 1-2
- attaching mountable board to chassis (illustration), 5-2
- cover for rack mount, 5-3
- double-height mounting (illustration), 5-2 to 5-3
- grounding, 5-2

- illustration, 1-2
- installation instructions, 5-1 to 5-3
- locations for SC-205X and SC-206X Series boards (illustration), 5-2
- SC-2060 board, 2-4
- SC-2061 board, 3-4
- SC-2062 board, 4-4 to 4-5

N

NC connection, SC-2062 board, 4-1, 4-2

NO connection, SC-2062 board, 4-1, 4-2

O

onboard equivalent circuit (illustration)

- SC-2060 board, 2-2
- SC-2061 board, 3-2
- SC-2062 board, 4-2

operating environment specifications

- SC-2060 board, 2-4
- SC-2061 board, 3-4
- SC-2062 board, 4-4

operation of SC-206X Series boards, 5-8 to 5-9

optically isolated digital input, SC-2060 board, 2-3

optically isolated digital output, SC-2061 board, 3-3

optional equipment, 1-4

optocoupler input, SC-2060 board, 2-2

optocoupler output, SC-2061 board, 3-3

P

physical specifications

- SC-2060 board, 2-4
- SC-2061 board, 3-4
- SC-2062 board, 4-4

pinout for connector J1 (illustration), 5-7

ports. *See* digital port operation of SC-206X Series boards.

power requirement specifications

- SC-2060 board, 2-3
- SC-2061 board, 3-3
- SC-2062 board, 4-4

power selection. *See* internal or external power selection.

R

relay contacts, SC-2062 board, 4-2. *See also* American Zettler relays.
 relay digital output, SC-2062 board, 4-3

S

S1 switch. *See* switch S1.
 safety information, 5-9 to 5-10
 SC-205X Series cable adapter board
 connections, 5-5 to 5-8
 cable connector J1, 5-7 to 5-8
 damage caused by incorrect connection, 5-7
 pinout (illustration), 5-7
 signal descriptions, 5-7
 connectors compatible with SC-206X Series boards (table), 5-8
 damage caused by incorrect connection, 5-8
 illustration, 5-6
 installation of SC-205X Series cable adapter board, 5-1
 overview, 1-1
 rack mounting (illustration), 1-2
 SC-2060 board, 2-4
 connected to data acquisition board (illustration), 1-2
 SC-2061 board, 3-4
 SC-2062 board, 4-5
 SC-206X Series boards. *See also* installation.
 additional software not required, 1-3
 component boards, 1-1
 contents of kit, 1-3
 external mounting
 alternative methods, 1-2
 illustration, 1-2
 optional equipment, 1-4
 purpose, *ix*, 1-1
 unpacking, 1-4
 SC-2060 board, 2-1 to 2-4
 computers supported, 2-1
 connected to data acquisition board via SC-2050 board (illustration), 1-2
 connector J1, 2-2
 damage resulting from incorrect signal connections, 2-3
 digital input circuitry, 2-2

 features, 2-1
 mounting and connection to data acquisition boards, 2-4
 onboard equivalent circuit (illustration), 2-2
 parts locator diagram, 2-1
 power circuit (illustration), 2-2
 power selection, 2-2
 screw terminals, 2-1
 shock hazard when connecting or disconnecting signal lines, 2-3
 specifications, 2-3 to 2-4
 operating environment, 2-4
 optically isolated digital input, 2-3
 physical, 2-4
 power requirements, 2-3
 storage environment, 2-4
 SC-2061 board, 3-1 to 3-4
 computers supported, 3-1
 connecting to data acquisition board via SC-2050 board, 3-4
 connector J1, 3-1 to 3-2
 damage resulting from incorrect signal connections, 3-2
 digital output channels, 3-2
 features, 3-1
 mounting and connection to data acquisition boards, 3-4
 onboard equivalent circuit (illustration), 3-2
 parts locator diagram, 3-1
 power selection, 3-1 to 3-2
 purpose, 3-1
 screw terminals, 3-1, 3-2
 shock hazard when connecting or disconnecting signal lines, 3-2
 specifications, 3-3 to 3-4
 operating environment, 3-4
 optically isolated digital output, 3-3
 physical, 3-4
 power requirements, 3-3
 storage environment, 3-4
 SC-2062 board, 4-1 to 4-5
 COM connection, 4-1, 4-2
 computers supported, 4-1
 connector J1, 4-2
 damage resulting from incorrect signal connections, 4-2
 features, 4-1
 mounting and connection to data acquisition boards, 4-4 to 4-5

- NC connection, 4-1, 4-2
- NO connection, 4-1, 4-2
- onboard equivalent circuit (illustration), 4-2
- parts locator diagram, 4-1
- power selection, 4-2
- purpose, 4-1
- relay contacts, 4-2
- shock hazard when connecting or disconnecting signal lines, 4-2
- specifications, 4-3 to 4-4
 - electromechanical relay digital output, 4-3
 - operating environment, 4-4
 - physical, 4-4
 - power requirements, 4-4
 - storage environment, 4-4
- screw terminals
 - SC-2060 board, 2-1
 - SC-2061 board, 3-1, 3-2
- shock hazard when connecting or disconnecting signal lines
 - SC-2060 board, 2-3
 - SC-2061 board, 3-2
 - SC-2062 board, 4-2
- signal description for connection J1, 5-7
- signal lines. *See* connecting or disconnecting signal lines.
- single-pole, dual-throw (SPDT) relays, 4-1
- specifications
 - SC-2060 board, 2-3 to 2-4
 - SC-2061 board, 3-3 to 3-4
 - SC-2062 board, 4-3 to 4-4
- storage environment specifications
 - SC-2060 board, 2-4
 - SC-2061 board, 3-4
 - SC-2062 board, 4-4
- switch S1
 - power selection settings (illustration), 5-5
 - selecting internal or external power, 5-4

T

- technical support, D-1

U

- ULN2801 array, B-1 to B-6
 - circuit schematics, B-6
 - electrical characteristics, B-3
 - electrical characteristics curves, B-5
 - illustration, B-2
 - maximum ratings, B-2
 - overview, B-2
 - pin connections, B-2
 - test figures, B-4
- unpacking SC-206X Series boards, 1-4