

# MODEL GWH 1600 PS

## INDOOR MODEL

Standing pilot, thermostatically modulated  
Suitable for heating potable water only  
Not approved for space heating  
For use with solar preheated water

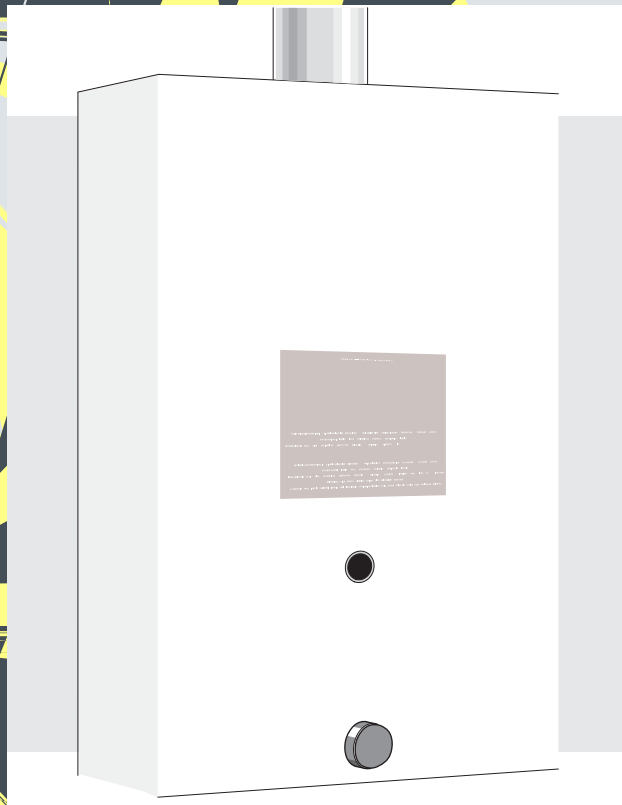

# BOSCH



MODEL GWH 1600 PS

O w

# Index

<b>1</b>	<b>Warning</b>	<b>2</b>
<hr/>		
<b>2</b>	<b>Appliance details</b>	<b>3</b>
2.1	GWH 1600 PS specifications (Technical data)	3
2.2	Unpacking the GWH 1600 PS heater	4
2.3	General rules to follow for safe operation	4
2.4	Dimensions	5
<hr/>		
<b>3</b>	<b>Installation instructions</b>	<b>6</b>
3.1	Introduction	6
3.2	Proper location for installing your heater	6
3.3	Heater placement and clearances	6
3.4	Mounting Heater	7
3.5	Combustion air requirements	8
3.6	Venting	9
3.7	Gas piping & connections	11
3.8	Measuring gas pressure	13
3.9	Water connections	13
3.10	Recirculation application	14
<hr/>		
<b>4</b>	<b>Operation instructions</b>	<b>14</b>
4.1	For your safety read before operating your water heater	14
4.2	Lighting instructions	15
4.3	To turn off appliance	15
4.4	Calibrating the thermostat	16
4.5	Winterizing	16
<hr/>		
<b>5</b>	<b>Maintenance and service</b>	<b>17</b>
5.1	Maintenance intervals	17
5.2	Water valve	17
5.3	Pilot	18
5.4	Main burners	18
5.5	Vent assembly	18
5.6	Mineral scale build-up	18
<hr/>		
<b>6</b>	<b>Troubleshooting</b>	<b>20</b>
6.1	Introduction	20
6.2	Pilot does not light	20
6.3	Pilot lights, but goes out when button released	20
6.4	Pilot goes out during or after hot water use	20
6.5	Burners do not light with water flow	20
6.6	Hot water temperature fluctuates at tap	20
6.7	Water is too hot	20
6.8	Water is not hot enough	22
6.9	Burners ignite without hot water flow	22
6.10	Low hot water pressure	22
6.11	Noise when heater is running	22
6.12	Burners do not operate cleanly; yellow flames when operating	22
<hr/>		
<b>7</b>	<b>Protecting the environment</b>	<b>23</b>
<hr/>		
<b>8</b>	<b>Interior components diagram parts list</b>	<b>24</b>
8.1	Interior components	24
8.2	Components diagram	25
8.3	Parts list	26
<hr/>		
<b>9</b>	<b>Two-Year Limited Warranty</b>	<b>27</b>

## 1 Warning



**Warning:** The heater must be isolated from the gas supply piping system during any pressure testing of that system at test pressures equal to or more than 0.5 psig.



**Caution:** Any changes or modifications not expressly approved by the party responsible for compliance could void the user's authority to operate the equipment.

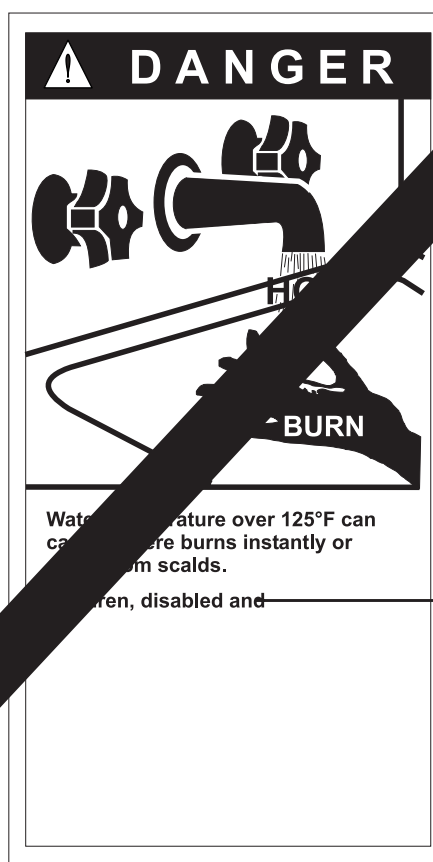

Fig. 1

## 2 Appliance details

### 2.1 GWH 1600 PS specifications (Technical data)

Approved in US/Canada

#### Capacity

GWH 1600 PS: 4.3 GPM

#### Maximum output

GWH 1600 PS: 96,600 Btu/hr

#### Maximum input

GWH 1600 PS: 117,000 Btu/hr

#### Efficiency in %

Recovery efficiency 80%

#### Min. Output

GWH 1600 PS: 23,400 Btu/hr

#### Gas Requirement

Gas connection (inches) - 1/2" NPT

Inlet gas pressure under maximum operation\*

- Propane: 10.5" - 14" water column
- Natural Gas: 5.7" - 14" water column.

\* To measure Gas Pressure, see Measuring Gas Pressure, chapter 3.8.

#### Venting

- Natural Draft
- Vent diameter (inches) - 5"
- Minimum height (feet) - 6' with no elbows
- Vertical termination
- Sidewall termination only with AQ1 power vent kit.

#### Water

- Hot water connection (inches) - 1/2" NPT
- Cold water connection (inches) - 1/2" NPT
- Water valve material: Brass
- Minimum water flow: 0.5 gallon/minute (1.9 l/m)
- Minimum recommended water pressure: 30 PSI (2.07 bar)
- Connections:
  - Bottom of heater

#### Dimensions

- Depth (in): 8 3/4" (222 mm)
- Width (in): 18 1/4" (463 mm)
- Height (in): 29 3/4" (756 mm)
- Weight: 44 lb (20 kg).

#### Gas types

Natural Gas.  
LP Gas

#### Safety devices

- Flame failure device (ionization thermocouple)
- Pressure relief valve (supplied with heater)
- Over heat prevention (temperature limiter).

## 2.2 Unpacking the GWH 1600 PS heater

This heater is packed securely.

**Before installing the unit, be certain you have the correct heater for your type of Gas - Propane or Natural Gas.** Identification labels are found on the shipping box, and on the rating plate sticker which is located on the right side panel of the cover.

MODEL # / N° DE MODELE	FD # / N° DE SERIE	
ORDER # / N° DE COMMANDE		
AUTOMATIC INSTANTANEOUS WATER HEATER / CHAUFFE EAU INSTANTANEE AUTOMATIQUE		
ANSI Z223.1/NFPA 54		
CSA 4.3 2001		
GAS WATER HEATERS / CHAUFFE EAU		
GAS WATER HEATERS / CHAUFFE EAU		
FOR OPERATION AT OUTLET WATER TEMPERATURE OF 140°F		
HYDROSTATIC PRESSURE 300 psi MAX. HYDROSTATIC WORKING PRESSURE 150 psi.		
POUR LE FONCTIONNEMENT A UNE TEMPERATURE DE 140° F A LA DECHARGE.		
SOUMIS A UNE PRESSION HYDROSTATIQUE MAX. 300 psi. PRESSION HYDROSTATIQUE DE FONCTIONNEMENT 150 psi.		
0 - 2000 Ft. (0 - 610 m.) SEMI-RANGE ALL ALTITUDE NORMALE	RATINGS AT ALTITUDE / EVALUATION A DIFFERENTE ALTITUDE	2000 - 4500 Ft. (610 - 1370 m.) HIGH ALTITUDE HAUTE ALTITUDE
MAX. INPUT BTU/H	CONSUMATION MAX. BTU/H	
MIN. INPUT BTU/H	CONSUMATION MIN. BTU/H	
REC. RATING, U.S. GAL/MIN.	RECOMMAND. U.S. GAL/MIN.	
ORIFICE SIZE	TAILLE DES ORIFICES	
INLET PRESS., IN W.C.	PRESSION D'ENTREE EN Po	
VENT. DIAM., INCHES	DIAMETRE DU CONDUIT DE CHEMINEE	
MIN. GAS SUPPLY PRESS., IN W.C.	LA PRESSION MINIMUM DU GAZ EN Po	
FOR PURPOSE OF RATE ADJUSTMENT	POUR RAISON D'AJUSTEMENT	
SI.	SI.	

Fig. 2 Rating plate sticker

- A Serial number
- B Type of gas

The box includes:

- Pressure relief valve
- Mounting screws
- Product registration card
- Installation manual (additional copies can be downloaded at [www.boschwaterheating.com](http://www.boschwaterheating.com))
- Incandescent particle tray.

Please complete and return the enclosed product registration card.

**The GWH 1600 PS is not approved or designed for:**

- Manufactured (mobile) homes, RV's, boats or any mobile installation
- Heating or other recirculating/pumping applications\*
- Installation in a bathroom, bedroom or any other habitable room normally kept closed.

\* This includes domestic hot water circulator pump loop systems that may be installed in home hot water system prior to installing this unit. An approved recirculation design can be found in chapter 3.10.

## 2.3 General rules to follow for safe operation

- **1.** You must follow these instructions when you install your heater. In the United States: The installation must conform with local codes or, in the absence of local codes, the National Fuel Gas Code ANSI Z223.1/NFPA 54.

In Canada: The Installation must conform with CGA B149.(1,2) INSTALLATION CODES and /or local installation codes.

- **2.** You must vent your heater. See section on VENTING.
- **3.** Carefully plan where you install the heater. Correct combustion air supply and vent pipe installation are very important. If not installed correctly, fatal accidents can be caused by lack of air, carbon monoxide poisoning or fire.
- **4.** The appliance and its gas connection must be leak tested before placing the appliance in operation. The appliance must be isolated from the gas supply piping system by closing its individual manual gas shutoff valve (not supplied with heater) during any pressure testing at pressures in excess of 1/2 Psig (3.5 kPa).
- **5.** Keep water heater area clear and free from combustibles and flammable liquids. Do not locate the heater over any material which might burn.
- **6. Correct gas pressure** is critical for the optimum operation of this heater. Gas piping must be sized to provide the required pressure at the maximum output of the heater, while all the other gas appliances are in operation. Check with your local gas supplier, and see chapter 3.7 and 3.8 to verify proper gas line sizing.
- **7.** Should overheating occur or the gas supply fail to shut off, turn off the gas supply at the manual gas shut off valve, on the gas line. Note: manual gas shutoff valve is not supplied with the heater.
- **8.** Do not use this appliance if any part has been underwater. Immediately call a qualified service technician to inspect the appliance and to replace any part of the control system and any gas control which has been underwater.
- **9.** Failure to install heater correctly may lead to unsafe operation and void the warranty.
- **10.** The heater must not be installed in an unheated area where temperatures will reach 36°F or lower. If the heater is left in an area susceptible to such temperatures, refer to section 4.5 on Winterizing.
- **11.** In areas where water supply has a high mineral content, a water softener is strongly recommended. Damage to the water heater resulting from hard water/scale deposits will not be covered under warranty.

## 2.4 Dimensions

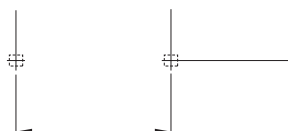

- 40 Gas valve
- 49 Observation window
- 50 Piezo Igniter button
- 51 Off button
- 52 Pilot button
- 53 On button

### 3 Installation instructions

#### 3.1 Introduction

Please follow these instructions. Failure to follow instructions may result in:

- ▶ Damage or injury.
- ▶ Improper operation.
- ▶ Loss of warranty.

If you are unable to perform the tasks required to install this heater properly, please contact a locally licensed plumber or gas technician.

Please contact Bosch Water Heating with any questions.

#### 3.2 Proper location for installing your heater

Carefully select the location of the water heater. For your safety and for proper heater operation, you must provide combustion air to the heater and a proper exhaust vent system.

Follow the guidelines below:

- ▶ **1.** Locate the heater where venting, gas and plumbing connections are feasible and convenient.
- ▶ **2.** The hot water lines should be kept short to save energy. Centrally locating the water heater is best. It is always best to have hot water lines insulated.
- ▶ **3.** Do not install in a bathroom, bedroom or any other habitable room normally kept closed.



**Warning:** The water in this water heater is cold and always remains cold except for the times that hot water is being used. **DO NOT INSTALL IN AN AREA WHERE IT COULD FREEZE.**

Drain the heater entirely if freezing temperatures are anticipated in area where heater is installed. See chapter 4.5 for draining instructions.

To prevent any freeze damage, introduce short bursts of compressed air (20-40psi) through these connections to remove the residual water in the horizontal pipes and water valve.



**Warning:** Flammable materials, gasoline, pressurized containers, or any other items or articles that are potential fire hazards must NOT be placed on or adjacent to the heater. The appliance area must be kept free of all combustible materials, gasoline and other flammable vapors and liquids.



**Warning:** The heater must be isolated from the gas supply piping system during any pressure testing of that system at test pressures equal to or more than 0.5 psig.



**Warning:** Place the heater in a location where water leaks will do NO DAMAGE to adjacent areas.

#### 3.3 Heater placement and clearances

The GWH 1600 PS is design certified for installation on a combustible wall (see 3.4 Mounting installation) provided the floor covering below the heater is noncombustible. For installations in an alcove or closet, maintain the minimum clearances to combustible and non-combustible materials listed below. See also Fig. 4.

- A. Top 12 inches (306 mm)
- B. Front 4 inches (100 mm)
- C. Back 0 inches
- D. Sides 4 inches (100 mm)
- E. Bottom 12 inches (306 mm)

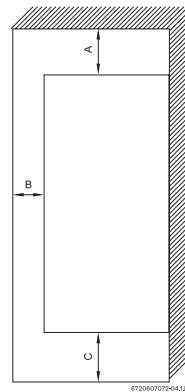

	Model GWH 1600
TOP (A)	12 inches (306 mm)
FRONT (B)	4 inches (100 mm)
BACK	0 inches
SIDES	4 inches (100 mm)
BOTTOM (C)	12 inches (306 mm)

Fig. 4 Minimum clearances

### 3.4 Mounting Heater

**Warning:** before starting installation:

- ▶ check that there are no loose parts inside the appliance
- ▶ ensure that gas pipe, gas valve, and burner have no damage and are properly fitted.
- ▶ Read chapter 2.2 to verify proper gas type and to check all parts are included in box.

**i** Front cover should be removed in order to inspect components visually (see instructions below).

#### Remove cover and inspect.

- ▶ Loosen the fixing screw, bottom of the front cover.
- ▶ Remove the outer cover by pulling it forwards and then lifting upwards, see Fig. 6.
- ▶ Ensure that the flue terminal is clear.
- ▶ After inspection, replace front cover.

#### Install incandescent particle tray.

- ▶ Install incandescent particle tray using screws provided as shown in Fig. 5.

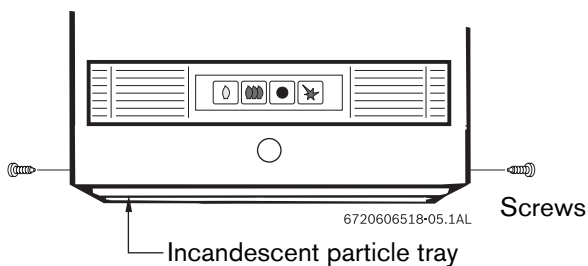

Fig. 5 Incandescent particle tray illustration

#### Mounting heater.

**Warning:**

- ▶ Do not install this appliance on a carpeted wall.

The heater must be mounted on a wall using appropriate anchoring materials. If wall is sheathed with plasterboard, it is recommended that support board(s), either 1x4's or 1/2" (minimum) plywood first attached across a pair of studs and then the heater should be attached to the support board.

- ▶ Secure the two included L shaped brackets to wall studs or support board 13 1/4" apart. (See Fig. 7).
- ▶ Hang heater on two L shaped hooks. (See Fig. 8).

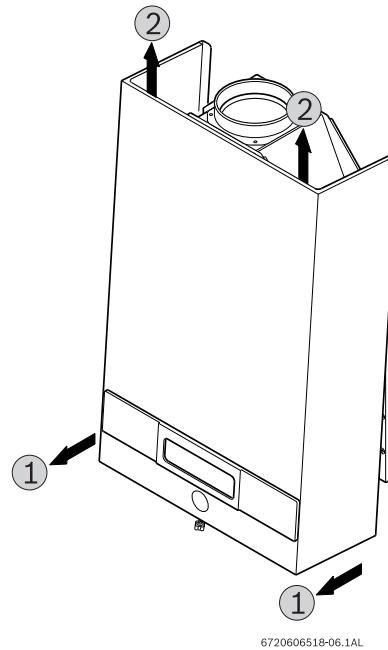

Fig. 6 Remove front cover

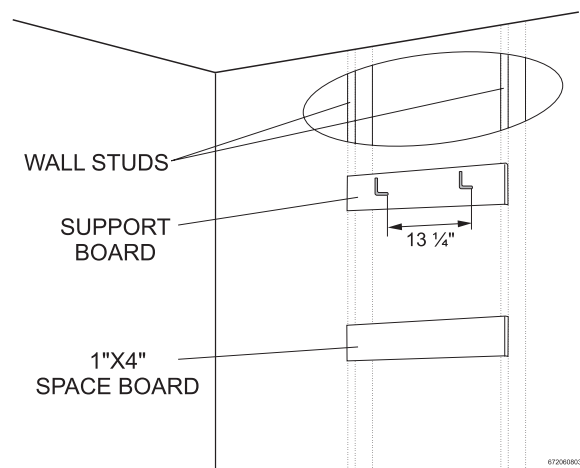

Fig. 7 Support board

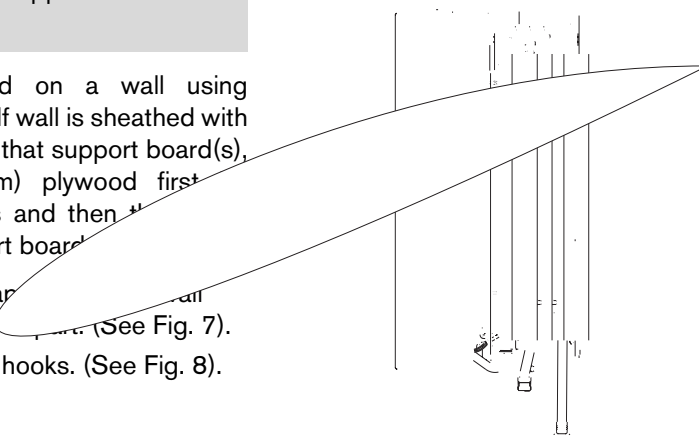

Fig. 8 Secure heater to wall

### 3.5 Combustion air requirements

The AquaStar water heater holds cold water in its copper heat exchanger and water valve when not in use. Because of this, any cold air that comes down through the unit's vent pipe is capable of freezing these components. This installation manual specifies the minimum vertical vent pipe height and the amount of combustion air required for this unit. When all requirements are followed, the unit will operate properly and safely. However, there may still be a risk of freezing due to negative draft if all the combustion appliances in the building are not being supplied with a sufficient amount of make-up air. A wood stove or furnace can pull cold air down the Aquastar's vent pipe, freezing the cold water in the heat exchanger or water valve causing damage. Supplying more combustion air for all combustion appliances is the solution. A HVAC specialist should be consulted to design solutions for providing more make-up air if necessary. Observe the following guidelines concerning combustion air.

#### **Appliances located in unconfined spaces:**

- a)** An unconfined space is one whose volume is greater than 50 cubic feet per 1000 Btu per hour of the combined rating of all appliances installed in the space. That would be 5850 cubic feet for the AquaStar GWH 1600 PS alone.
- b)** Installations in structures that have been tightly constructed (air infiltration rate of 0.40 ACH or less) must be provided with combustion air per the National Fuel Gas Code. Consult a HVAC specialist if your air infiltration rate is questionable.

#### **Appliances located in confined spaces:**

The confined space must be provided with two permanent openings, one commencing within 12 inches of the top and one commencing within 12 inches of the bottom of the enclosure. Each opening must have a minimum free area of one square inch per:

- 1000 Btu/hr if all air is taken from inside the building.
- 2000 Btu/hr if all air is taken from the outside by horizontal ducts.
- 4000 Btu/hr if all air is taken from the outside by direct openings or vertical ducts.

Or the confined space must be provided with one permanent opening or duct that is within 12 inches of the ceiling of the enclosure. This opening must have a minimum free area of one square inch per:

- 3000 Btu/hr if all air is taken from the outside by a direct opening or vertical duct.

Louvers, grills and screens have a blocking effect. If the effective free area is not known, increase the sizes of your openings by 400% if your louvers are wood and by 135% if your louvers are metal. Refer to the National Fuel Gas Code for complete information. In buildings of tight construction all air should be taken from outside.



vent pipe  
y on top  
venting  
exhaust

with no elbows  
w

the following all  
installing a gas  
must be located  
ing chimney or  
mination point.  
d constructed  
to remove flue  
onal Fuel Gas  
e venting with

vent with  
e.

g to a  
k along  
is not

g to a  
t power

of-draft safety  
le for sidewall  
omwealth of  
ns must utilize

### 3.6.1

- ▶ A 5 inch diameter gas vent constructed of double wall Type B gas vent is required. A 6 inch vent is required in elevations greater than 2000 feet, see Fig. 10. Under no circumstances should the vent pipe be reduced in size.
- ▶ An approved gas vent connector must be attached to the top of the water heater and rise vertically at least 12" before entering into an approved gas vent connector elbow.
- ▶ The minimum vertical gas vent height allowed is 6 feet; horizontal vent connectors and elbows are not to be considered in the total gas vent height.

Fig. 9 Flat roof

Fig. 10 Vent Adaptor for High Altitude Installations

**Masonry chimney**

Masonry chimneys shall be built and installed in accordance with NFPS 211 or local codes. A minimum 5" diameter gas vent pipe (metal double wall Type B), or an approved clay flue liner or a listed chimney lining system must be used when venting into a naturally drafting, internal masonry chimney. 6 inch is required in elevations greater than 2000 feet, see Fig. 10. Local codes may require the use of both gas vent and an approved lining system when venting into a masonry chimney. The Commonwealth of Massachusetts requires the use of a listed liner. Lining systems include approved clay flue lining, a listed chimney lining system or other approved material that will resist corrosion, erosion, softening, or cracking from exhaust flue gases at temperatures up to 1800 degrees F. The lining system must be listed for use with naturally drafting, draft hood equipped gas appliances. Follow local codes and refer to NFGC 54 and NFPA 58.

**Existing interior masonry or tile lined chimney**

The metal gas vent pipe should be permanently mounted inside the masonry chimney. Double wall Type B gas vent is recommended. The masonry chimney may have to be tile or metal lined before the insertion of the gas vent pipe; check local codes for clarification. The lining material must be listed for use only with naturally drafting, draft hood equipped gas appliances. Follow manufactures instructions for installation of listed lining material. You may not vent any other fuel burning appliances into any free space remaining in the chimney. The minimum vertical gas vent length within the masonry chimney should be no less than 6 ft (1.8 m); the vent terminator should extend at least 3 feet (0.9 m) above where the chimney meets the roofline and at least 2 feet (0.6 m) higher than any vertical wall or similar obstruction within 10 feet (3.1 m). The top of the gas vent must have an approved vent terminator. See Fig. 12.

**Exterior Masonry Chimney**

Refer to the National Fuel Gas Code and consult a local venting HVAC contractor. Not recommended in cold climates.

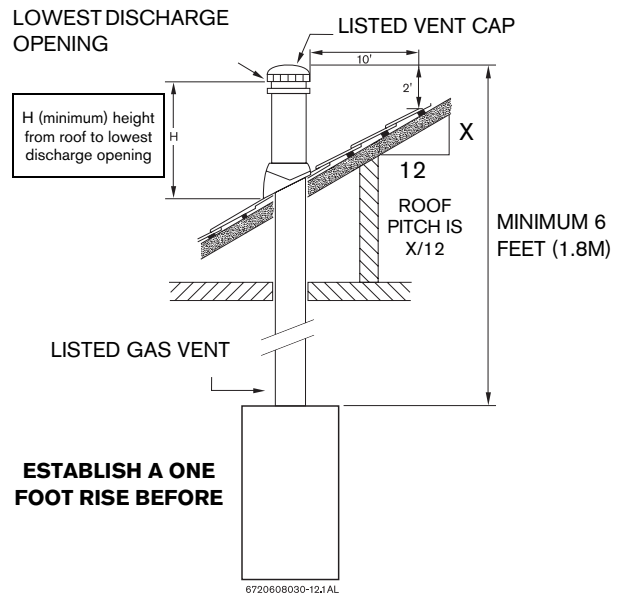

Fig. 11 Pitch roof

GAS VENT TERMINATIONS FOR LISTED VENT CAPS		
Roof pitch	H (minimum) feet	meters
Flat to 6/12	1.0	0.30
6/12 to 7/12	1.25	0.38
Over 7/12 to 8/12	1.5	0.46
Over 8/12 to 9/12	2.0	0.61
Over 9/12 to 10/12	2.5	0.76
Over 10/12 to 11/12	3.25	0.99
Over 11/12 to 12/12	4.0	1.22
Over 12/12 to 14/12	5.0	1.52
Over 14/12 to 16/12	6.0	1.83
Over 16/12 to 18/12	7.0	2.13
Over 18/12 to 20/12	7.5	2.27
Over 20/12 to 21/12	8.0	2.44

Table 2

Fig. 12 Masonry chimney

### 3.7 Gas piping & connections



Before connecting the gas supply, check the rating plate sticker on the right side of the heater to be sure that the heater is rated for the same gas to which it will be connected.

In the United States: The installation must conform with local codes or, in the absence of local codes, the National Fuel Gas Code ANSI Z223.1/NFPA 54.

In Canada: The Installation must conform to CGA B149 INSTALLATION CODES and/or local installation codes.

Mount regulator to gas inlet pipe as shown in Fig. 13. The arrow on the back of the regulator indicates the direction of gas flow and must point toward the appliance.

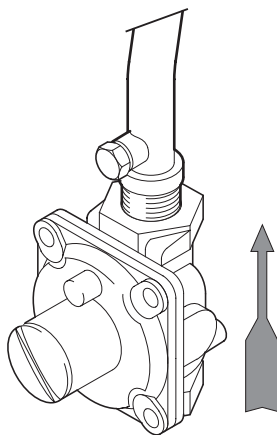

Fig. 13 Installation of Gas Pressure Regulator

**Note:** The GWH 1600 PS comes with a gas pressure regulator. Not installing or altering the gas pressure regulator will be a violation of CSA certification of the unit. The regulator supplied with the heater is preset for the gas shown on the rating plate to the correct pressure. It is an appliance level regulator designed for (low inlet) pressure (less than 1/2 Psig or 14" W.C.).



**Warning:** DO NOT connect to an unregulated or high pressure propane line or to a high pressure commercial natural gas line.



**Warning:** The heater must be isolated from the gas supply piping system during any pressure testing of that system at test pressures equal to or more than 0.5 psig. If overpressure has occurred, such as through improper testing of the gas lines or malfunction of the supply system, the gas valve must be checked for safe operation.

#### GAS CONNECTIONS

- ▶ Install a manual gas shut off valve, on the gas supply line.

- ▶ Install a union when connecting gas supply.
- ▶ Attach the supplied appliance regulator to the inlet gas pipe.
- ▶ The minimum diameter required for any appliance connector used is 3/4".
- ▶ National Fuel Gas Code requires that a sediment trap (drip leg) be installed on gas appliances not so equipped. The drip leg must be accessible and not subject to freezing conditions. Install in accordance with the recommendations of the serving gas supplier.

When connections are made, check for gas leaks at all joints. Apply some gas leak detection solution to all gas fittings. Bubbles are a sign of a leak. A combustible gas detector may also be used to detect for leaks.



**Danger:** If you have a leak, shut off the gas. Tighten appropriate fittings to stop leak. Turn the gas on and check again with a gas leak detection solution. Never test for gas leaks using a match or flame.

#### HIGH ALTITUDE INSTALLATION

The pressure regulator provided with the heater is adjusted to deliver the proper gas pressure (as indicated on the rating plate and in the manual for altitude up to 2000 feet (660 meters) above sea level. On appliances being installed above 2000 ft (660 meters) elevation, the inlet gas pressure should be set at installation to the value shown below.

**Note:** The gas pressures specified below refer to pressures taken at the pressure tap on the gas inlet pipe just above the regulator. See chapter 3.8 for measuring gas pressure.

#### MAXIMUM INLET GAS FLOW PRESSURE SETTING

Altitude	Nat. Gas inches W.C.	Liquid Propane inches W.C.
0' - 2 000 ft	5.7"	10.5"
2 000 ft - 4 500 ft	4.6"	8.4"

Table 3 Above 4.500 ft consult your local gas provider

#### GAS LINE SIZING

The gas supply piping should be sized according to the applicable code for a maximum draw of 117,000 BTUH. Measure the length of gas supply line and use the tables in Fig. 14 or the gas line manufacturer's sizing tables to determine the pipe diameter necessary to accommodate the BTU demand of the unit. If there are more gas appliances drawing on the same line, size the gas line according to the total maximum amount of BTU draw for all appliances.

**Note:** Under sizing the gas line may result in diminished output and improper operation. See chapter 3.8 for the procedure to confirm gas pressure.

**Installation instructions**

**FOR NATURAL GAS**

Maximum Capacity of pipe in Cubic Feet of Gas per Hour for Gas Pressure of 0.5 Psig or less and a Pressure drop of 0.3 in Water Column (0.75mbar).(Based on a 0.60 Specific Gravity Gas) Btu numbers given in thousands. Copper tubing is prohibited for use with Natural Gas in the Commonwealth of Massachusetts and not recommended elsewhere.

Follow boxed numbers for piping just one GWH 1600 PS (example: 3/4" B.I. Natural Gas pipe for 20 ft (6.1m). will handle 190,000 btu's (55.7 kWh). For multiple appliances combine the total btu input load and then refer to applicable chart below.

Nominal Iron Pipe Size inches	Internal Diameter inches	Length of Black Iron Pipe, Feet													
		10	20	30	40	50	60	70	80	90	100	125	150	175	200
3/4	0.824	278	190	152	130	115	105	96	90	84	79	72	64	59	55
1	1.049	520	350	285	245	215	195	180	170	160	150	130	120	110	100
1 1/4	1.380	1050	730	590	500	440	400	370	350	320	305	275	250	225	210

Length of Flexible Corrugated Stainless Steel Tubing (CSST), Feet Tube size, inches	EHD*						
		10	20	30	40	50	60
1/2	18 EHD	82	58	47	41	37	34
3/4	23 EHD	161	116	96	83	75	68
1	30 EHD	330	231	188	162	144	131
1 1/4	37 EHD	639	456	374	325	292	267

\* EHD = Equivalent Hydraulic Diameter. The greater the value of EHD, the greater the gas capacity of the tubing.

**FOR LP GAS**

Maximum Capacity of Pipe in Thousands of BTU per Hour of Undiluted Petroleum Gases (at 11 inches Water Column Inlet Pressure) (Based on a Pressure Drop of 0.5 Inch Water Column).

\* EHD = Equivalent Hydraulic Diameter. The greater the value of EHD, the greater the gas capacity of the tubing.

Nominal Iron pipe size inches	Black Iron Pipe Length of pipe, Feet											
	10	20	30	40	50	60	80	100	125	150	200	
1/2	291	200	160	137	122	110	94	84	74	67	58	
3/4	608	418	336	287	255	231	197	175	155	140	120	
1	1145	787	632	541	480	434	372	330	292	265	227	

Length of Flexible Corrugated Stainless Steel Tubing (CSST), Feet Tube size inches	EHD*						
		10	20	30	40	50	60
1/2	18 EHD	129	91	74	64	58	53
3/4	23 EHD	254	183	151	131	118	107
1	30 EHD	521	365	297	256	227	207
1 1/4	37 EHD	971	661	528	449	397	359

Maximum Capacity of Semi-Rigid copper Tubing in Thousands of BTU per Hour of Undiluted Liquefied Petroleum Gases (at 11 inches Water Column Inlet Pressure).

(Based on a Pressure Drop of 0.5 Inch Water Column)

\* Source National Fuel Gas Code NFPA 54, ANSI Z223.1 - No Additional Allowance is necessary for an ordinary number of fittings

Outside diameter Inch	Copper (LP gas only) Length of Tubing, Feet									
	10	20	30	40	50	60	70	80	90	100
3/8	39	26	21	19	-	-	-	-	-	-
1/2	92	62	50	41	37	35	31	29	27	26
5/8	199	131	107	90	79	72	67	62	59	55
3/4	329	216	181	145	131	121	112	104	95	90

Fig. 14

### 3.8 Measuring pressure

- ▶ Proper gas pressure must be verified before installation.

#### Connect manometer

- ▶ Shut off gas with installed supplied shutoff valve. Remove cover to locate inlet gas regulator, see Fig. 15. Remove cover from test point above the test point and connect

ably rated stainless steel flex line piping be used at least three feet before and after the heater (follow codes if more stringent). Never sweat any rigid piping directly to or beneath the water connections or leakage can occur to the internal water valve from sweating of the pipe. Plastics or other PEX type plumbing materials are not recommended for connecting directly to the water heater. Keep water inlet and outlet pipes to no less than 1/2" (12.7mm) diameter to allow the full flow capacity.

It is recommended that all water piping after the heater be properly insulated to avoid heat loss.

If the cold and hot connections to the heater are reversed, the heater will not function. Be certain there are no loose particles or dirt in the piping. Blow out or flush the lines before connecting to the water heater. Full port shutoff valves should be installed on both the cold water supply and hot water outlet lines to facilitate servicing the heater (see Fig. 16). For installation on a private well system with the use of a pressure tank, the lowest pressure range setting recommended is 30-50 psi (2.07 and 3.45bar)

#### Connecting the pressure relief valve (PRV)

The pressure relief valve supplied with the heater must be installed at the time of installation. No valve is to be placed between the PRV and the heater. No reducing coupling or other restriction may be installed in the discharge line. The discharge line must be a minimum of 4" above a drain and installed such that it allows complete drainage of both the PRV and the line.

The local code may require the PRV to be installed in a specific location. See the local code for details.

Fig. 15 Pressure measuring point

A

#### Start gas test

- ▶ Check all other gas appliances at their input.
- ▶ Check gas supply back on.
- ▶ Check static gas pressure reading at test point.

#### Operating pressure

- ▶ Turn on gas supply to all gas appliances served by the water heater.
- ▶ Check for gas leaks at all gas appliances or same gas piping.
- ▶ Check for gas leaks at all gas piping.
- ▶ Check operating gas pressure reading on back of gas valve.

Pressure lower than 5.0 bar (72.5 psi) for Natural Gas or 3.5 bar (50.8 psi) for LP Gas should be corrected. Use of water being used should be corrected. See the local code for details.

#### 3.9 Water connections

When installing the heater, the 1/2" cold water inlet is on the bottom right and the hot water outlet is on the top right.

#### Install full port shutoff valves and isolate connections to facilitate any necessary servicing.

Although water piping throughout your structure may be other than copper, we recommend copper piping for the water heater connections.

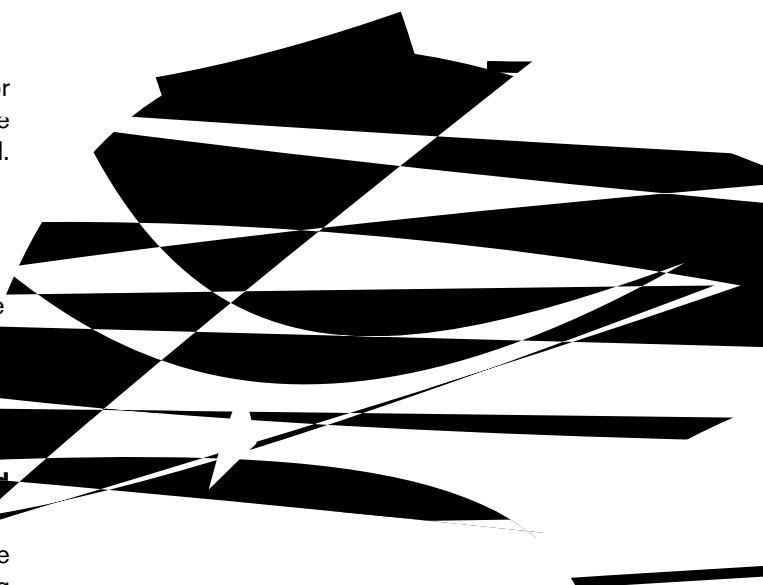

### 3.10 Recirculation application

Since recirculation through tankless water heater is not permissible, the following drawing is provided to outline a proper recirculation application using the Aquastar water heater with an Ariston tank water heater. This schematic is for illustration only and must not be used for actual installation without appropriate engineering and technical advice from a professional properly licensed in locality where the installation is made.

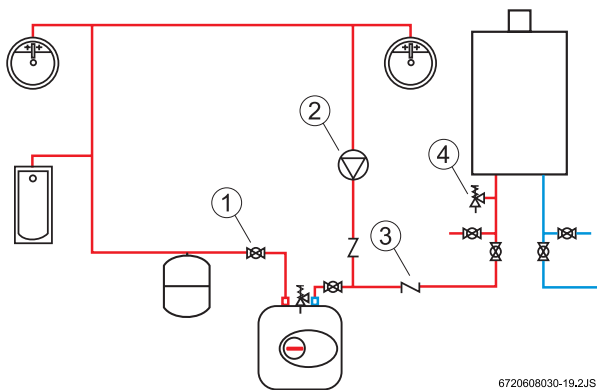

Fig. 17 Recirculation application

The use of a small electric mini-tank (4-6 gallon size) should be used for this application and designed so the pump will circulate the water through the mini-tank and the building's hot water return loop only. A timed or thermostatically controlled operation of the pump is commonly done. The GWH 1600 PS should be plumbed in line before the mini-tank water heater. Contact Bosch Water Heating if further instruction is needed.

## 4 Operation instructions

### 4.1 For your safety read before operating your water heater



**Warning:** If you do not follow these instructions exactly, a fire or explosion may result causing property damage, personal injury or loss of life.



**Note:** Upon initial installation, existence of air in the gas supply line and in the water line may cause some ignition delay. In that case, repeat the ignition process until all the air has been purged.

**A.** This appliance employs a piezo-igniter to light the pilot burner. When lighting the pilot, follow these instructions exactly.

**B.** What to do if you smell gas.

- ▶ Close gas valve. Open windows.
- ▶ Do not try to light any appliance.
- ▶ Do not touch any electric switch; do not use any phone in your building.
- ▶ Immediately call your gas supplier from a neighbors phone. Follow the gas supplier's instructions.
- ▶ If you cannot reach your gas supplier, call the fire department.

**C.** Use only your hand to push in the gas control buttons. Never use tools. If a button will not push in, check to make sure the buttons are being pushed in the proper sequence. Follow these instructions exactly. If control button(s) are jammed, close the heater's individual manual gas shutoff valve and call a qualified service technician. Forced or attempted repair may result in a fire or explosion.

**D.** Do not use this appliance if any part has been under water. Immediately call a qualified service technician to inspect the appliance and to replace any part of the control system and any gas control which has been under water.

## 4.2 Lighting instructions

- ▶ STOP! Read the previous safety information.
- ▶ The gas valve must be turned off by pushing the gas valve off (●) button.

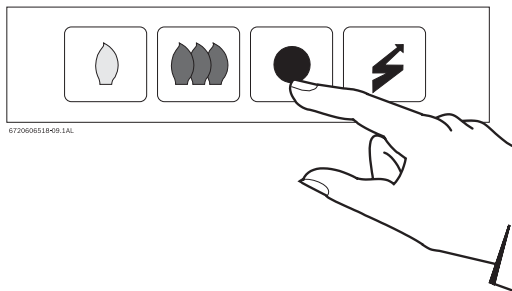

Fig. 18

- ▶ Wait five (5) minutes to clear out any gas. If you smell gas, STOP! Follow “B” in chapter 4.1. If you don’t smell gas, go to next step.
- ▶ The pilot burner window is located in the front center of the cover (Fig. 3, num. 49).
- ▶ Fully depress pilot button (🔥).

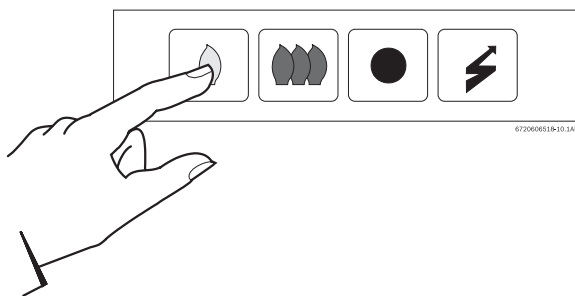

Fig. 19

- ▶ With the pilot button fully depressed, light pilot by pushing the piezo button (⚡). This step may have to be repeated until pilot is lit.

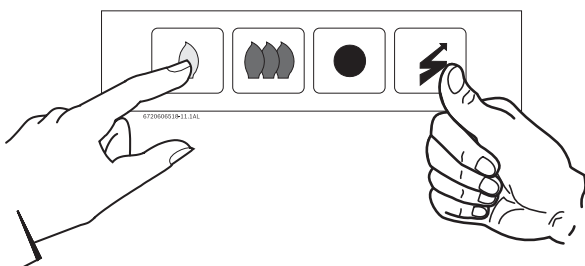

Fig. 20

- ▶ Observe the pilot flame through the pilot burner window. The pilot button should be pushed in for at least 15 seconds with pilot burning before releasing. When the pilot button is released, the pilot should continue to burn.
  - If the pilot button does not pop out to an intermediate position when released, stop and immediately call your service technician or gas supplier.

- If pilot does not stay lit, repeat all steps.
- If pilot will not stay lit after several tries, push the gas valve off button (●) all the way in and call service technician or gas supplier.

- ▶ When lit, depress the on (🔥) button. The heater will now fire at minimum power when water is drawn at a rate greater than the required activation flow rate.

**Note:** If main burner does not ignite, make sure pilot is burning. If not, repeat lighting steps.

## 4.3 To turn off appliance

- ▶ Push the gas valve off button (●) all the way in and turn off the installer supplied manual gas shutoff on the supply line to the heater.

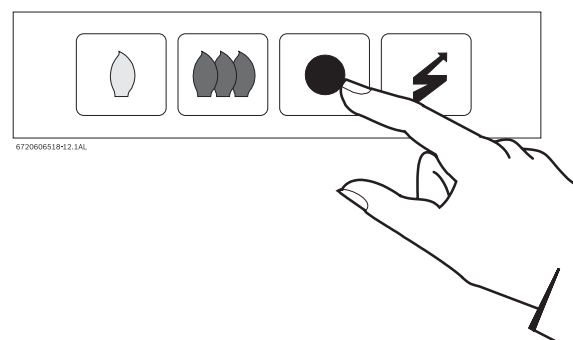

Fig. 21

zing

reezing, proceed as follow  
et and outlet elbow conn  
valv

- ▶ Remove the drain plug from the under s  
water valve.

**Caution:** it should not be necessary to  
loosen 22 mm nut beyond two turns out  
this is a gas seal and will leak if loosened  
too far.

- ▶ Loosen the lock-nut collar above the 22 mm nut to begin the calibration procedure. A seal of yellow paint will be broken when it is loosened. See diagram below.

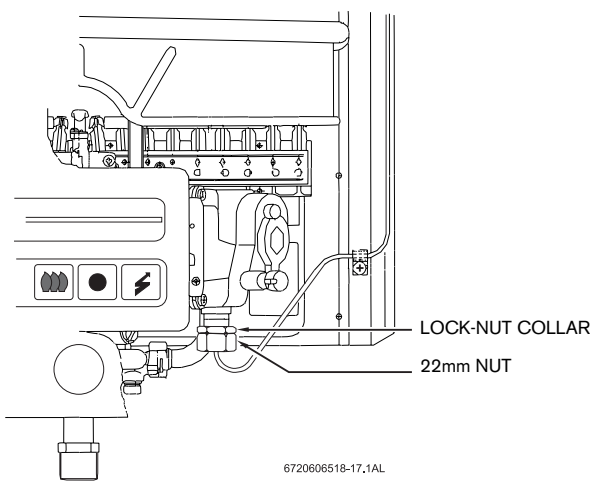

Fig. 22

- ▶ Turning the 22 mm nut (upwards) will lower the flame height. Loosening (downwards) will raise the flame height. When making an adjustment it is recommended to have water flowing and the heater on, then at 1/4 turn increments of the 22 mm nut, test the temperature of the outlet water by measuring the hot water temperature at an open tap.

**Note:** If the water temperature does not vary when the thermostat is adjusted then it needs to be replaced.

**Note:** The thermostat's modulation will respond sooner with varying flow rates of preheated water. Although varying flows of cold water will be sensed by the thermostat there will often be a delay to stabilize temperature.

- ▶ Retighten lock-nut collar against 22 mm nut when calibration is complete. Replace front cover panel.

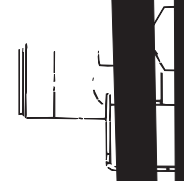

Fig. 23 Drain plug and fit

- 1 Water valve
- 2 From heat exchanger
- 3 Slow ignition valve
- 4 To heat exchanger
- 5 Drain plug



## 5 Maintenance and service

### 5.1 Maintenance intervals



**Warning:** Failure to perform recommended maintenance may result in complete failure of the unit over time. The warranty does not cover failures due to improper or insufficient maintenance.

The GWH 1600 PS requires periodic maintenance. The below time maintenance intervals should keep the unit operating for many years.

#### Every year

- ▶ Inspect inlet water filter screen ( 5.2)
- ▶ Inspect pilot assembly and flame ( 5.3)
- ▶ Inspect burner assembly ( 5.4)
- ▶ Inspect vent system for blockage

#### Every 2 years

- ▶ Lubricate and clean water valve ( 5.2)

#### Every 3 to 5 years

- ▶ Rebuild water valve ( 5.2)
- ▶ Clean pilot assembly and clean or replace orifice ( 5.3)

### 5.2 Water valve

The water valve is the main control that tells the heater to fire. If the periodic maintenance is neglected, more costly damage may occur over time.

#### Inspecting inlet water filter screen

Shut off the installer supplied cold water isolation valve to the heater. If one is not installed, install before proceeding. Open the nearest hot water tap to drain the plumbing lines. Position a bucket under the heater's water valve assembly to catch any water that may drain from the heater. Remove cold water supply connection on rear right-hand side of water valve. Inlet filter is recessed inside water valve. Carefully pry filter screen out with a blunt object. Clean with water and inspect for damage. If the filter is at all damaged, it should be replaced.

#### Lubricating the water valve

A more detailed instruction is available on our website at [www.boschhotwater.com](http://www.boschhotwater.com). Shut off the installer supplied cold water isolation valve to the heater. If one is not installed, install before proceeding. Open the nearest hot water tap to drain the plumbing lines. Position a bucket under the heater's water valve assembly to catch any water that may drain from the heater. Remove water pipes connected to the back of

the water valve. Remove heat exchanger piping connected to the right and left side of water valve. Loosen the two set screws (Fig. 27, num. 36) at the top of the water valve where it connects to the gas valve. If the set screws are seized, STOP and call Bosch tech support before proceeding. Forcing and snapping seized set screws may cause irrevocable damage to the water valve and gas valve assemblies. Remove the water valve from the heater by pulling it down. Once free from the heater, separate the two halves of the water valve by removing the three screws on the top of the water valve. Apply lithium or faucet & valve grease to the pushrod and o-ring. (See Fig. 25, num. 27). With needle-nosed pliers, remove recessed venturi tube from right hand port on water valve (Fig. 27, num. 32). Inspect venturi and clean if necessary. If plugged with mineral deposits, soak in straight vinegar for at least one hour prior to cleaning.

#### Rebuilding the water valve

Several parts within the water valve should be replaced every 3 to 5 years depending on water quality and usage. The parts list and instructions can be found on our website at [www.boschhotwater.com](http://www.boschhotwater.com). Failure to rebuild the water valve can result in decreased performance or damage to the heater.

### 5.3 Pilot

#### Inspecting pilot

The pilot should burn with a clean sharp blue flame. The flame should fully engulf the tip of the thermocouple. If it does not, clean the pilot assembly using the procedure below.

#### Cleaning pilot assembly

- **1.** Shut off gas to heater using installer supplied manual gas shutoff, then remove front cover.
- **2.** Carefully loosen 8 mm pilot tube nut shown below. Once loosened with wrench, continue by hand. Do not pull pilot tube down. Follow next step.
- **3.** Remove both pilot bracket screws that mount to front of burners.

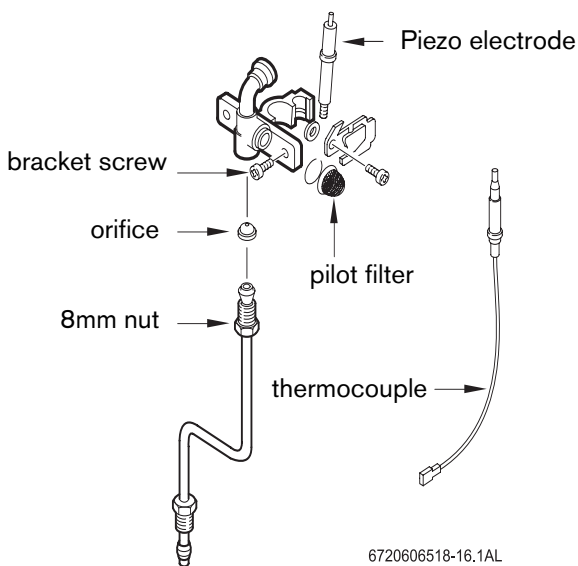

Fig. 24 Pilot assembly



**Caution:** Pilot orifice may fall out when pilot tube and pilot bracket are separated.

- **4.** Lift up pilot bracket slowly (8 mm nut may need to be loosened further)
- **5.** The pilot orifice sits on top of the pilot tube. Stamped on it will be a number identifying the gas type. [5 - Natural Gas] [49 - LP].
- **6.** We recommend that you replace if dirty or clogged (especially LP). If cleaning, compressed air or aerosol sprayed carburetor cleaner will work. Soak in cleaner if necessary..



**Caution:** Do not ream or poke orifice as it will enlarge orifice opening.

- **7.** Blow through pilot burner that is affixed to the pilot bracket. If air screen on right side of pilot bracket is dirty or clogged, remove and clean.

- **8.** Place new or cleaned pilot orifice back on top of pilot tube.
- **9.** Set pilot bracket on top of the pilot tube.
- **10.** Begin to hand thread the 8 mm nut to the pilot bracket being sure not to cross thread. Once started tighten pilot bracket to front of burners with both screws.
- **11.** Carefully tighten 8 mm nut with wrench.
- **12.** Turn on gas and check for a leak at the 8 mm nut connection by applying soap solution, then pushing in pilot button. Bubbles are a sign of a leak.
- **13.** If no leaks are found replace front cover and return heater to service.

### 5.4 Main burners

The main burner flames should be blue, with a more intense blue cone in the center core. Yellow flames could be a sign of wrong size gas orifices, dirty burners or a blockage on the heat exchangers fins. If some burners have yellow flames while others have blue flames, it is likely that dust, lint or spider webs have partially clogged the burner venturis. To clean the burners, contact a gas service person.

### 5.5 Vent assembly

Inspect the draft hood and heat exchanger fins for signs of soot build-up or any other foreign material such as spider webs. Clean out any debris found in the vent hood. Signs of soot indicate insufficient combustion air or exhaust draft. Check for vent assembly blockage or combustion air blockage on the underside of the unit.

### 5.6 Mineral scale build-up

The GWH 1600 PS, when operated at lower temperatures settings, does not accumulate mineral build-up. If however, the heater is used at the higher temperature settings and the water has a high mineral content, periodic descaling may be necessary. The heat exchanger should be flushed with a descaling solution.

#### 5.6.1 Descaling heat exchanger

1. Shut off the water supply to the water heater using (installer supplied) shutoff valves.
2. Open hot water taps to drain and relieve pressure from the plumbing system
3. Drain water from the unit's heat exchanger by disconnecting inlet and outlet water connections
4. Connect the line (A) from the outlet of the circulating pump (installer supplied) to the inlet water fitting on the water heater
5. Using another line (B), connect to the water outlet fitting on the water heater. Route the other end of this line into a descaling reservoir

6. Using a 3rd line (C) from the descaling reservoir, connect to the inlet side of circulating pump. Verify there is a filter on the end of the line in the descaling reservoir.
7. Make sure all connections are "hand tight."
8. Fill tank with descaling solution so lines inside are submersed. We recommend a straight white vinegar solution. If using a commercial descalant, refer to manufacturer's instructions on dilution with water.
9. Operate the circulating pump.
10. Make sure there are no leaks and the solution is flowing from the descaling reservoir through the heat exchanger and returning to the reservoir.
11. Run solution through the heat exchanger until the solution returning to the descaling reservoir comes out clear. (Changing to a fresh solution may be necessary during this process).
12. Disconnect all lines and drain all solution from heat exchanger. Properly discard of solution
13. Position a container below the hot water outlet and connect cold water supply. Open cold water supply isolation valve and flush heat exchanger with clean water.
14. Shut cold water isolation valve and reconnect hot water supply to the water heater.
15. Open water isolation valves, and return the unit to service.

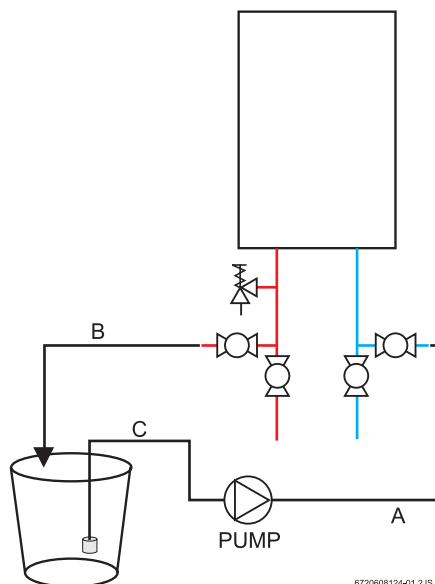

Fig. 25

# 6 Troubleshooting

## 6.1 Introduction

Many of the questions customers ask regarding operation of this unit can be answered by following the troubleshooting steps as outlined below. Visit our web site at [www.boschhotwater.com](http://www.boschhotwater.com) for more detailed troubleshooting. For best results, perform each step before proceeding to the next. The suggested solutions may require that the cover be taken off. (See chapter 3.4).

## 6.2 Pilot does not light

1. Verify gas supply is on at Natural Gas meter or Propane Tank. Make sure all manual gas shut off valves are in the open position. Have licensed gas technician confirm adequate gas pressure at the inlet tap (chapter 3.8). If gas is not present, verify manufacturer supplied Maxitrol regulator is in the upright position. The arrow on the back of the regulator must point in the same direction as gas flow.

2. If the unit was just installed or the gas lines have been worked on, there may be air in the gas line. Push in the pilot button while pushing the pilot igniter button every few seconds. It may take several minutes to bleed air out of the gas line.

3. Verify a spark is being thrown at pilot area while pilot button is being firmly depressed. Repeatedly push in pilot igniter button to light the pilot. If no spark is present, verify proper wire connection to the electrode.

4. Pilot assembly may be blocked. Clean or replace the pilot orifice (chapter 5.3).

## 6.3 Pilot lights, but goes out when button released

1. When lighting pilot ensure the pilot button is fully depressed and held in for at least 20 seconds after pilot is lit.

2. Verify gas type indicated in rating sticker located on right hand side of cover, coincides with the gas type you are using. NG is a natural gas unit and LP is for liquid propane.

3. If using a power vent, check the safety spillage switch reset button (the safety spillage switch is wired through the water heater's thermocouple circuit). The spill switch should be mounted at the top of water heater on the draft diverter (Consult power vent manual for location).

4. Check all connections of the pilot safety circuit. The pilot safety circuit consists of a thermocouple, overheat sensor (ECO), safety spillage switch (models with power vents only) and the electromagnet (See parts diagram for locations). Clean sensor connections with light sandpaper if corrosion is evident. The

electromagnet connection is 5mm nut from the thermocouple which screws into a larger 24mm nut. Tighten both nuts snugly but do not over tighten.

5. Pilot flame should be blue in color and completely engulfing the tip of the thermocouple. If not, have a licensed gas technician verify gas pressure is in accordance with manufacturer's specifications (see chapter 3.8) and clean or replace the pilot orifice (see chapter 5.3).

6. Have a licensed gas technician verify the proper operation of the thermocouple by measuring the millivoltage from the thermocouple lead to ground. The proper reading should be 24mVDC or greater. If the reading is lower and the pilot is engulfing the thermocouple tip, the thermocouple may be defective. Call Bosch Water Heating for further instruction.

## 6.4 Pilot goes out during or after hot water use

1. Pilot outage during use typically results from the unit's safety overheat/high limit sensors interrupting the pilot circuit.

2. Failure to vent properly by reducing pipe diameter, improper use of elbows or not meeting required vent length are common causes that deactivate the pilot safety circuit. Confirm venting is in accordance with manufacturer's specifications (see chapter 3.6).

3. Confirm the combustion air requirements are being met in accordance with manufacturer's specifications (see chapter 3.5). Proper venting and combustion air will ensure a proper draft.

4. Confirm that the burners in the water heater go off immediately when the hot water is turned off. If they remain on or shut down slowly, then the overheat sensor (ECO) will interrupt the pilot circuit and shut off all gas to the heater. The water valve assembly, which actuates the burners, may be dirty and requires periodic maintenance (every 2 - 5 years depending on water quality and use) (see chapter 5.2).

5. Check all connections of the pilot safety circuit. The pilot safety circuit consists of a thermocouple, overheat sensor (ECO), safety spillage switch (models with power vents only) and the electromagnet (See parts diagram for locations). Clean sensor connections with light sandpaper if corrosion is evident. The electromagnet connection is 5mm nut from the thermocouple which screws into a larger 24mm nut. Tighten both nuts snugly but do not over tighten.

6. Verify pilot is a steady blue flame that completely engulfs the thermocouple tip. If pilot flame is too small, clean pilot orifice (see chapter 5.3).

7. If the water has a high mineral content, the heat exchanger may be scaled internally. This restricts the

water path, causing the water to over heat which shuts all gas off to the heater. See chapter 5.6.1 for descaling instructions.

8. If steps 1 through 7 do not correct the problem, then confirm that the gas pressure is adequate. Ensure gas pressure is in accordance with manufacturer's specifications (see chapter 3.8). A gas pressure reading is needed to proceed further. Contact your original installer or a licensed gas technician to obtain this reading.

## 6.5 Burners do not light with water flow

1. Verify the pilot is lit
2. Verify the 3-flame button (  ) is pushed in.
3. Verify the cold water supply is connected to the right side of the heater.
4. Close installer supplied cold water shut off valve (if none installed, install before proceeding). Open all hot water taps supplied by the heater. Wait 5 minutes and check all taps. Any water running is a sign of a plumbing crossover. Consult a local plumber or service person for help in correcting a plumbing crossover.
5. Verify flow through the water heater is sufficient. Fully open a hot water faucet and fill a quart container. If the container fills in 30 seconds or less, the flow rate (1/2 gallon per minute) is sufficient to activate the heater.
6. Inspect the water path outside of the heater for obstructions. Make sure all showerheads, faucet aerators and whole house filters are clear of debris. Also, the water heater's inlet filter screen should be inspected and cleaned (see chapter 5.2).
7. The water valve assembly, which actuates the burners, requires periodic maintenance (every 2 - 5 years depending on water quality and use) (see chapter 5.2).

## 6.6 Hot water temperature fluctuates at tap

1. Close off installer supplied cold water shut off valve (if none installed, install before proceeding). Open all hot water taps supplied by the heater. Wait 5 minutes and check all taps. Water running is a sign of a plumbing cross-over. Consult a local plumber or service person for help in correcting a plumbing crossover.
2. Check for a clogged inlet water filter screen (see chapter 5.2).
3. Hot water is very hot out of the tap, requiring a lot of cold water to be added with it in order to attain a useable hot water temperature. The addition of too much cold will overpower and slow the flow within the tankless water heater, decreasing it below activation point, which shuts off the burners. The end result is nothing but cold water coming out of the outlet.

Recalibrate thermostat for cooler outlet temperatures. (See chapter 4.4).

4. The GWH 1600 PS is designed to modulate gas flow to the burners when water flow varies. If the water pressure in the home is erratic and the water flow is not consistent while a tap is opened, then the temperature of hot water will fluctuate. The minimum water pressure for the home should be 30psi or greater. For installation on a private well system with the use of a pressure tank, the lowest pressure range setting recommended is 30-50 psi (2.07-3.45 bar). The use of a pressure reducing/regulating valve before the water heater (directly after pressure tank on well systems) is an effective way to maintain constant water pressure to the water heater. Watts brand 25AUB- 3/4" or N35B-3/4" pressure reducing/regulating valves or equivalent are suggested.

5. A temperature balance shower valve can automatically mix in cold water to reduce hot water temperatures. This can slow the flow within the tankless water heater, decreasing it below activation point, which shuts off the burners. In the event of any temperature instability with the use of a temperature balance shower valve, refer to shower valve manufacturer's instructions for internal adjustment setting. An adjustment should be made to minimize the amount of cold water the valve is adding.

6. The gas pressure also needs to be stable and adequate. Ensure gas pressure is in accordance with manufacturer's specifications (see chapter 3.8). A gas pressure reading is needed to proceed further. Contact your original installer or a local certified gas technician to obtain this reading.

7. A water valve which has not been serviced may be unable to keep the gas valve open. The water valve requires periodic maintenance (every 2-5 yrs depending on water quality and use) (see chapter 5.2)

## 6.7 Water is too hot

1. Verify gas type indicated in rating sticker located on right-hand side of cover, coincides with the gas type you are using. NG is a natural gas unit and LP is for liquid propane.
2. Recalibrate thermostat for cooler outlet temperatures. (See chapter 4.4).
3. Increase the flow rate. Restrictions in the water path can slow the flow of water through the heater, resulting in very hot outlet temperatures. Restrictive showerheads and faucet aerators should be cleaned or upgraded with less restrictive ones. In addition, the water heater's inlet filter should be cleaned and inspected (see chapter 5.2).
4. If the water has a high mineral content, the heat exchanger may be scaled internally. This restricts the water path, causing the water to boil and produce extremely hot temperatures. See chapter 5.6.1 for descaling instructions.

### 6.8 Water is not hot enough

1. Verify gas type indicated in rating sticker located on right-hand side of cover, coincides with the gas type you are using. NG is a natural gas unit and LP is for liquid propane.
2. Flow at one particular tap is too great or too many fixtures are running at one time. Lower flow to stay within heater's specifications.
3. Shut off installer supplied cold water shut off valve (if none installed, install before proceeding). Open all hot water taps supplied by the heater. Wait 5 minutes and check all taps. Any water running is a sign of a plumbing crossover. Consult a local plumber or service person for help in correcting a plumbing crossover.
4. Inspect the water path outside of the heater for obstructions. Make sure all showerheads, faucet aerators and whole house filters are clear of debris. Also, the water heater's inlet filter screen should be inspected and cleaned (see chapter 5.2).
5. Recalibrate thermostat for hotter outlet temperatures. (See chapter 4.4).
6. The water valve may be dirty, preventing it from fully opening the gas valve. This part needs to be periodically serviced (every 2-5 yrs depending on water quality and use) (see chapter 5.2).
7. Gas pressure is too low. Ensure gas pressure is in accordance with manufacturer's specifications (see chapter 3.8). A gas pressure reading is needed to proceed further. Contact your original installer or a local certified gas technician to obtain this reading.

### 6.9 Burners ignite without hot water flow

1. The water valve may be dirty and sticking, preventing it from fully closing the gas valve. The water valve needs to be periodically serviced (every 2-5 yrs depending on water quality and use) (see chapter 5.2).

### 6.10 Low hot water pressure

1. Confirm adequate flow rate through the unit. With cold supply shut off to the unit, disconnect hot outlet side to the unit. Place a gallon jug under a hot outlet to catch water. Open cold supply to the water heater and measure flow rate out of the unit. The flow rate should be close to 3.7gpm, filling the jug in less than 16 seconds. If the flow rate is not adequate, inspect and clean the inlet filter screen (see chapter 5.2).
2. Confirm the incoming water pressure to the unit is above the required 30psi.
3. Inspect the water path outside of the heater for obstructions. Make sure all showerheads, faucet aerators and whole house filters are clear of debris.
4. Be sure to run only one major application at a time with this unit. Opening too many taps at one time can

disperse water flow resulting in a diminished flow and pressure at all outlets.

5. If the water has a high mineral content, the heat exchanger may be scaled internally. This restricts the water path, causing diminished water flow. See chapter 5.6.1 for descaling instructions.

### 6.11 Noise when heater is running

1. Confirm adequate flow rate through the unit. With cold supply shut off to the unit, disconnect hot outlet side to the unit. Place a gallon jug under a hot outlet to catch water. Open cold supply to the water heater and measure flow rate out of the unit. The flow rate should be close to 3.7gpm, filling the jug in less than 16 seconds. If the flow rate is not adequate, inspect and clean the inlet filter screen (see chapter 5.2).
2. Inspect the water path outside of the heater for obstructions. Make sure all showerheads, faucet aerators and whole house filters are clear of debris. Restrictions in the water path can slow water flow through the heat exchanger causing it to boil and make noise.
3. Recalibrate the thermostat for cooler temperatures (see chapter 4.4). If the water temperature remains excessively hot when the thermostat is adjusted, then it should be replaced.
4. If the water has a high mineral content, the heat exchanger may be scaled internally. This restricts the water path, causing the water to boil resulting in noise and overheating. See chapter 5.6.1 for descaling instructions.

### 6.12 Burners do not operate cleanly; yellow flames when operating

1. Verify gas type indicated in rating sticker located on right-hand side of cover, coincides with the gas type you are using. NG is a natural gas unit and LP is for liquid propane.
2. Gas pressure may be inadequate resulting in improper combustion. Ensure gas pressure is in accordance with manufacturer's specifications (see chapter 3.8). A gas pressure reading is needed to proceed further. Contact your original installer or a licensed gas technician to obtain this reading.
3. For proper combustion at high elevations the inlet gas pressure should be set at installation to the value shown in chapter 3.7 Table 3 (while operating at maximum BTU). A gas pressure reading is needed to proceed further. Contact your original installer or a licensed gas technician to obtain this reading.
4. Ventilation is not adequate. Ensure adequate combustion air is being supplied to the unit in accordance with manufacturer's specifications (see chapter 3.5).

5. Make sure the water heater is vented properly. Check for proper draft and ensure venting is in accordance with manufacturer's specifications (see chapter 3.6).

6. The water heater has burners much like a furnace. It is essential that they remain clean and are supplied with adequate air for combustion. If the flames burn yellow or orange, it is strongly recommended that the burners be removed from the unit and cleaned. Once the burners are removed, the fins in the top of the heat exchanger can be accessed and should be brushed or vacuumed clean. Instructions to remove burners are available at [www.boschhotwater.com](http://www.boschhotwater.com).

## 7 Protecting the environment



### Packing

The packing box may be fully recycled as confirmed by the recycling symbol .

### Components

Many parts in the heater can be fully recycled in the end of the product life. Contact your local authorities for information about the disposal of recyclable products.

### Saving water resources:

- ▶ Make sure you close all the taps after any use. Avoid leaving the taps dripping. Repair any leaking tap.
- ▶ Set the water heat to the temperature you want. This way you have the precise water temperature needed (mixing cold water to regulate temperature will increase the water temperature with consequent waste of water).

## 8 Interior components and diagram parts list

### 8.1 Interior components

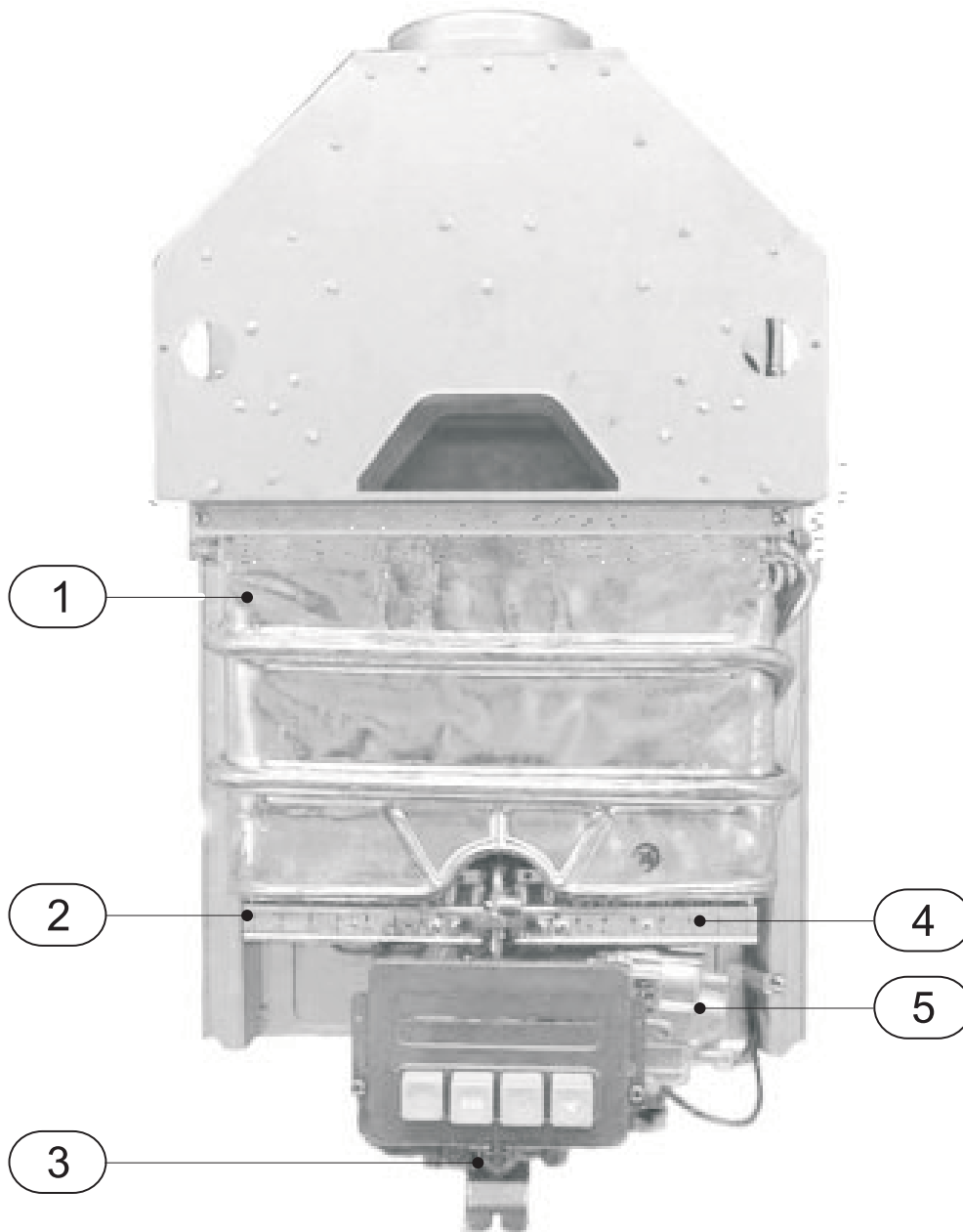
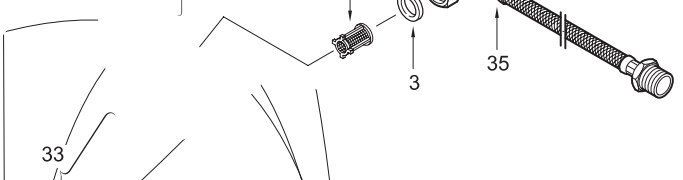
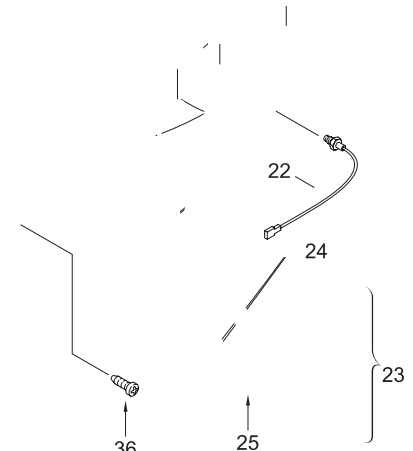
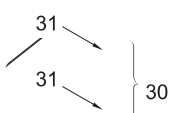
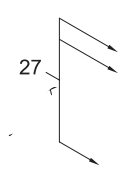
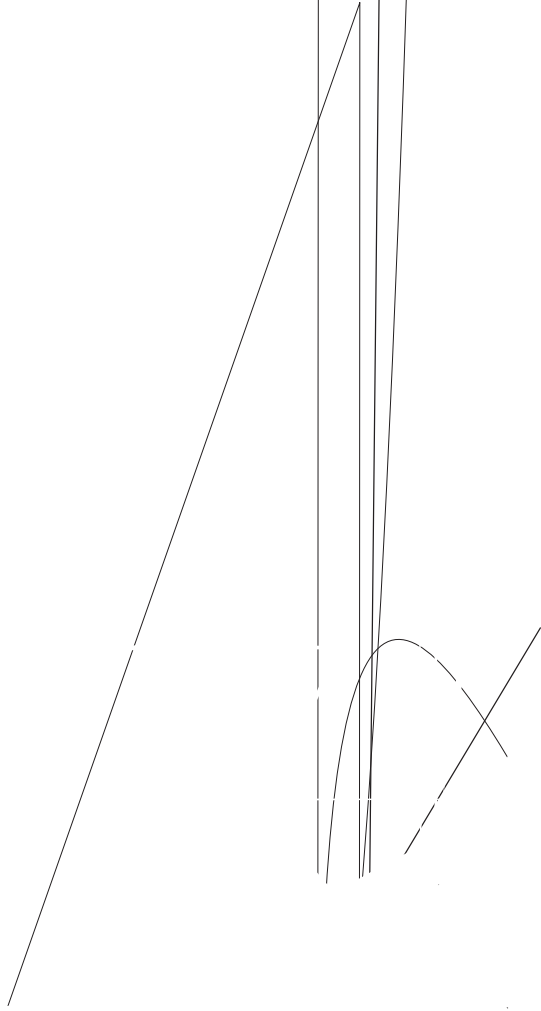

Fig. 26 Functional scheme

- 1 Heat exchanger
- 2 Burner manifold gas pressure test nipple
- 3 Water valve
- 4 Main gas burner
- 5 Gas valve





6720606518-14.1JF

### 8.3 Parts list

Item	Description	Reference
1	Cover	8 705 421 033
2	Cap cover	8 703 304 011
3	Water connection gasket	8 710 103 043
5	Heat exchanger	8 705 406 189
6	Hot water pipe	8 700 705 431
7	Cold water pipe	8 700 705 294
8	Heat exchanger washer	8 710 103 045
9	Overheat sensor (ECO)	8 707 206 017
10	Main burner assembly	8 708 120 296 LP
	Main burner assembly	8 708 120 298 NG
11	Pilot burner assembly	8 718 105 051
11a	Pilot filter screen	8 700 507 055
12	Piezo electrode	8 708 107 002
13	Pilot orifice	8 708 200 005 NG
	Pilot orifice	8 748 200 173 LP
14	Pilot Tube	8 710 707 166
15	Thermocouple	8 747 202 083
16	Burner assembly washer	8 710 103 060
17	Gas valve	8 707 011 467 LP
17	Gas valve	8 707 011 469 NG
18	Gas supply pipe	8 700 705 464
19	Electromagnet	8 747 201 094
20	Electromagnet washer	8 700 103 144
21	Gas filter	8 700 507 051
22	Thermocable	8 747 202 078
23	Thermostat	8 707 206 039
24	O ring Thermostat	8 700 205 101
25	O ring Thermostat	8 700 205 041
26	Water valve assembly	8 707 002 393
27	Pushrod	8 703 406 204
28	Water valve diaphragm	8 700 503 050
29	Slow ignition valve	8 708 503 062
30	Water valve setting screw	8 703 404 092
31	O ring setting screw	8 700 205 050
32	Water valve venturi	8 708 205 235
33	Water valve piston assembly	8 708 500 230
34	Water inlet filter	8 700 507 059
35	Water elbow fitting	8 700 703 114
36	Water valve set screw	8 703 401 051
37	Water valve drain screw	8 703 406 153

Table 4

## 9 Twelve Year Limited Warranty

### General

Aquastar water heaters are warranted by the Manufacturer (BOSCH) through BBT North America. BBT North America (BBTNA) will furnish a replacement heat exchanger and will furnish a replacement of any other part which fails in normal use and service within the applicable periods specified below, in accordance with the terms of this warranty. The BBTNA replacement will be warranted for the unexpired portion of the original warranty. This warranty will be valid only for water heaters in possession of the original purchaser as recorded on the warranty card.

### The Heat Exchanger

If the heat exchanger fails within twelve (12) years after the original installation and operation BBTNA will furnish a replacement heat exchanger. However, if the water heater is installed in other than a single family dwelling this heat exchanger warranty is limited to two (2) years from date of original installation and operation.

### Exceptions

This warranty will not apply:

- **1.** to defects or malfunctions resulting from failure to properly install, operate or maintain the unit in accordance with the printed instructions provided;
- **2.** to damage or abuse, accident, neglect or freezing and other acts of nature;
- **3.** to damage resulting from operation with either the flame sensor rod or overheat sensor removed;
- **4.** to failure of the heat exchanger resulting from the operation of the water heater in a corrosive atmosphere or at water temperatures exceeding the maximum rating, or if the water heater is not supplied with potable water;
- **5.** to defects or damage cause by any attachment or modification, including any energy-saving device.
- **6.** to damage resulting from scale deposits and/or highly mineralized/unsoftened water supply.

### All Other Parts

If any other part fails within two (2) years after original installation and operation, BBTNA will furnish a replacement part free of charge.

### Shipping costs

In addition to supplying the replacement part(s), BBTNA will provide ground service delivery for these parts. Expedited or upgraded shipping will be charged to the customer.

### Service Labor Costs

This warranty does not cover any labor costs associated with service, removal or re-installation of

part(s). All such costs must be borne by the Purchaser. Additionally, this warranty does not cover any labor costs associated with service, removal or re-installation of the original water heater or a replaced water heater.



Note: the water heater must be free of damaging scale deposits and not subject to gas pressures greater than those shown on the rating plate, which must not be altered, defaced or removed.

### How to Make a Claim

Any claim for warranty parts should be made to your local dealer, distributor or to BBTNA. If BBTNA, please contact the Technical Support Department:

**BBT NORTH AMERICA**  
 Bosch Group  
 340 Mad River Park  
 Waitsfield, VT 05673  
 Phone: 800-642-3111  
[www.boschhotwater.com](http://www.boschhotwater.com)

In most cases, the dealer or distributor will be able to promptly honor your claim and subsequently notify BBTNA. However, all replacements are made subject to validation by BBTNA of in-warranty coverage. The damaged or defective item must be made available in exchange for the replacement.

### Miscellaneous

No one is authorized to make any other warranties on behalf of BBTNA. It is expressly understood that the replacement warranty of BBTNA shall be in lieu of any and all other warranties, express or implied, including warranties of merchantability or fitness for a particular use or purpose, and further that BBTNA shall not be liable for any loss or damage directly or indirectly arising from the use of the hot water heater, or for any consequential damages arising from such use (including damages from water leakage). BBTNA sole liability with respect to any defect shall be for the replacement of the defective part(s). Some states do not allow such limitations and exclusions, so the above may not apply to you.

This warranty gives specific legal rights. You may also have other rights which vary from state to state.

## Installer Checklist, to be performed by installer upon installation

Serial Number

\_\_\_\_\_  
(8 digit serial number is located on rating plate on right side panel)

Gas Pressure Reading\*

Static \_\_\_\_\_ Operating \_\_\_\_\_

Building Water Pressure

\_\_\_\_\_ Range if on Well system \_\_\_\_\_

Average Winter Temperature

\_\_\_\_\_

Average Summer Temperature

\_\_\_\_\_

Installing Company

\_\_\_\_\_

Installer name

\_\_\_\_\_

Address

\_\_\_\_\_

Phone

\_\_\_\_\_

\* See Chapter 3.8 and gas pressure table (to be filled out by installer)

Installation manual should be left with the owner after the installation is tested and completed

**BBT NORTH AMERICA**  
Bosch Group

Bosch Water Heating  
340 Mad River Park  
Waitsfield, VT 05673  
Phone 800-642-3111  
Fax 802-496-6924  
[www.boschhotwater.com](http://www.boschhotwater.com)  
[techsupport@boschhotwater.com](mailto:techsupport@boschhotwater.com)

BBT Termotecnologia Portugal S.A.  
Estrada de Cacia  
3801 - 856 Aveiro - PORTUGAL