

Important Safety Advice:

1. Knowledge of the relevant electric technical regulations is required.
2. Training in use is compulsory.
3. Always use the correct tools.
4. Test every component before final operation.
5. Make familiar with the use of the system before initial operation.

USER'S MANUAL

SWING GATE OPENER SW200 SERIES

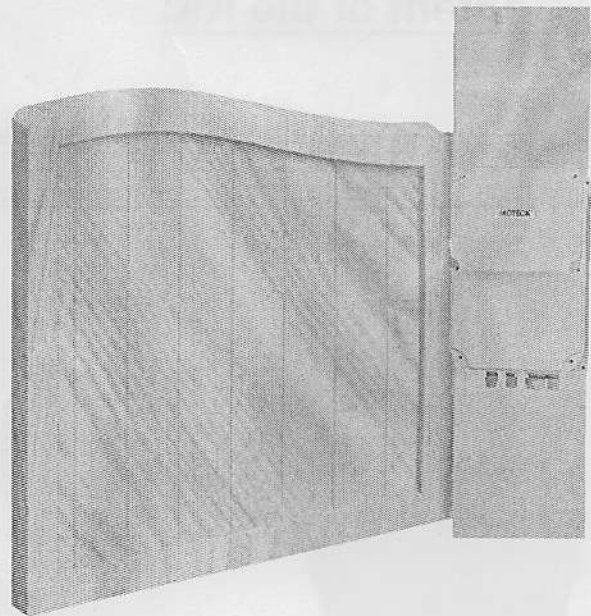
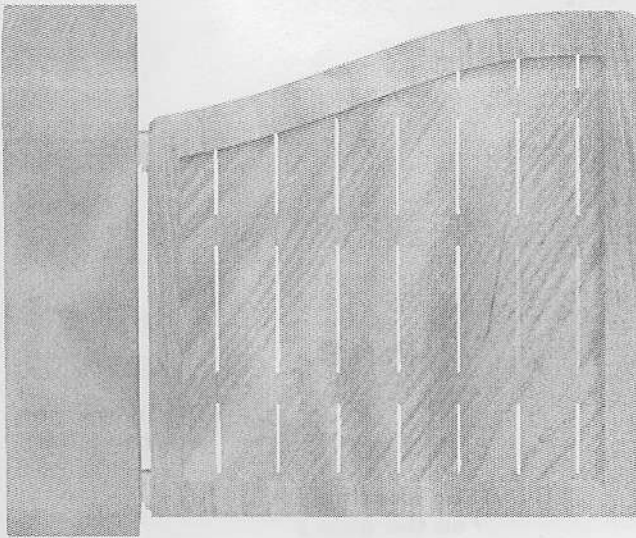

1.50m max.
100kg max.



1.50m max.
100kg max.

Important Safety Advice:

1. Knowledge of the relevant electro-technical regulations is required.
2. Training in use and maintenance of safety equipments is necessary.
3. Always lay mains and control cables separately.
4. Test every equipment before initial operation.
5. Make familiar with the use of the system before initial operation.

Content of the Kit:

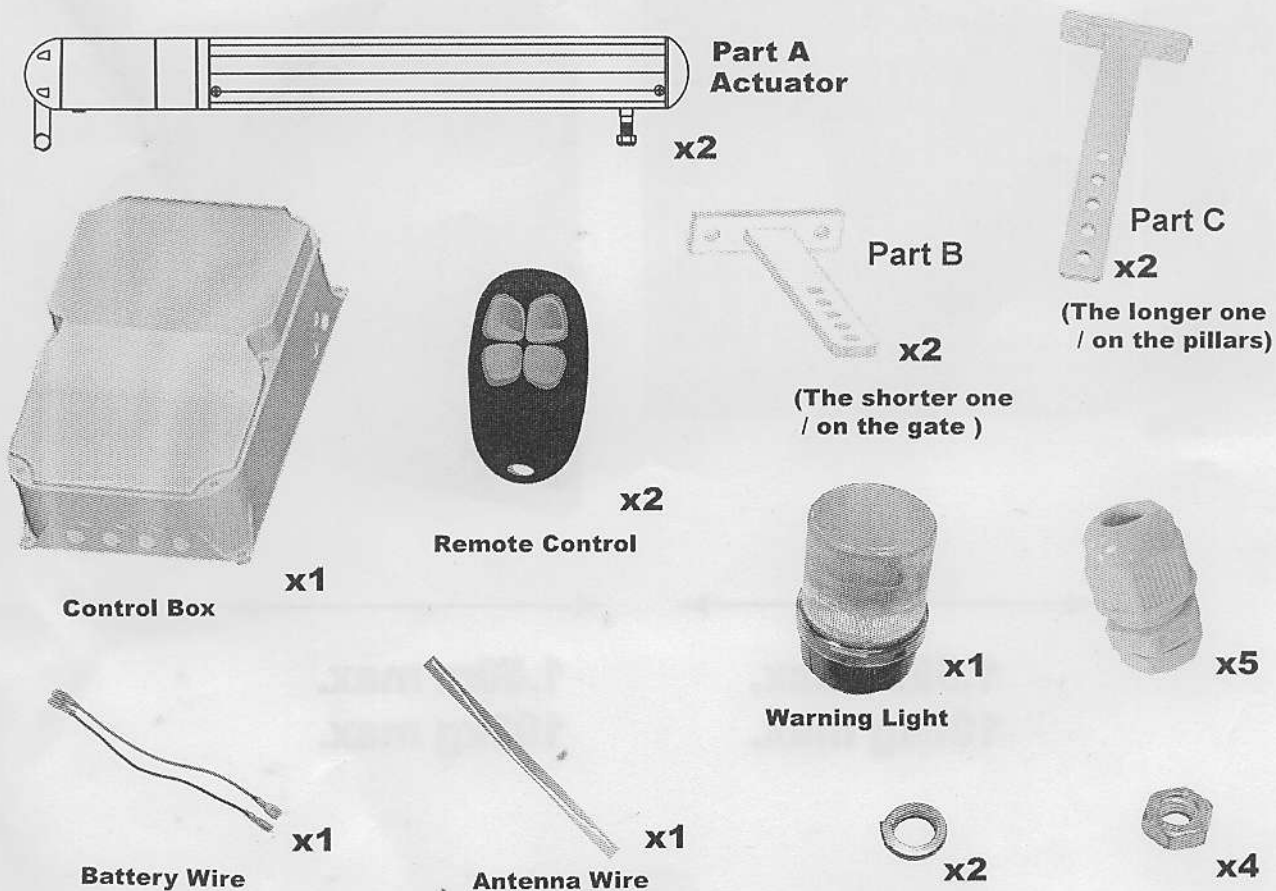

Wiring Diagram:

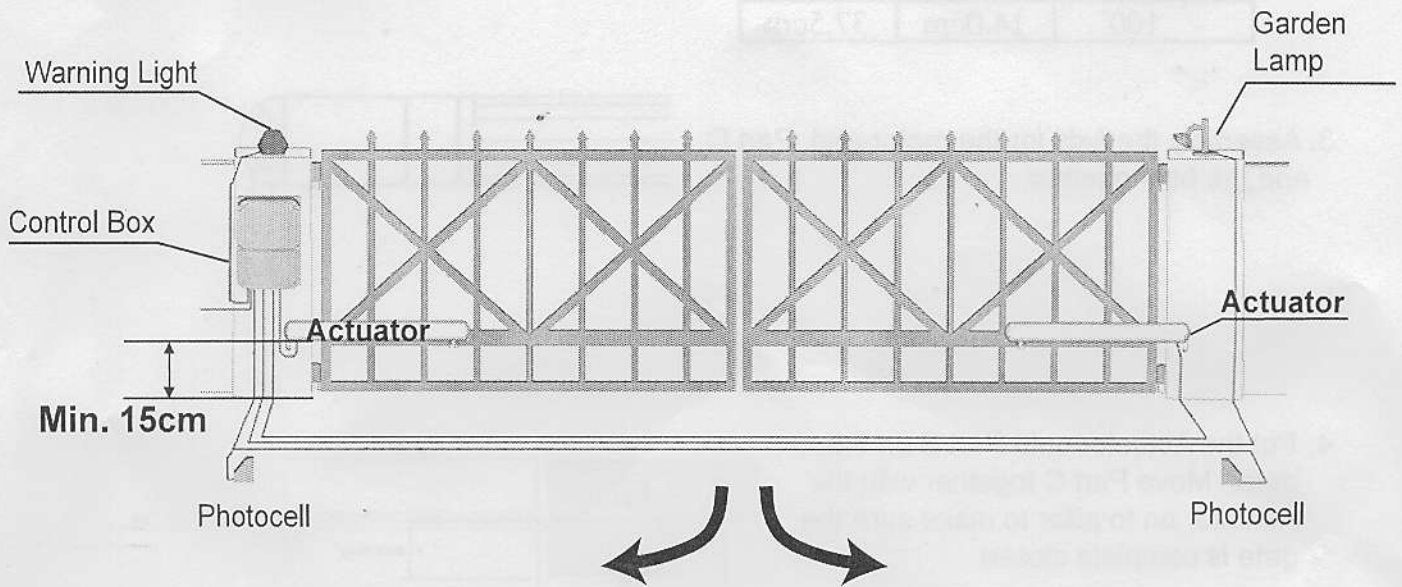

Instruction of Installation:

1. Keep a space of 5mm (default setting from factory) between the driving bolt and the metal cover of the motor.
2. Measure out the length of E on the figure1 as 36cm or 37.5cm. Use this point as a center point for fixing the T form metal (Part B) on the gate. Drill two holes on the gate to fix the Part B (the shorter T form metal).

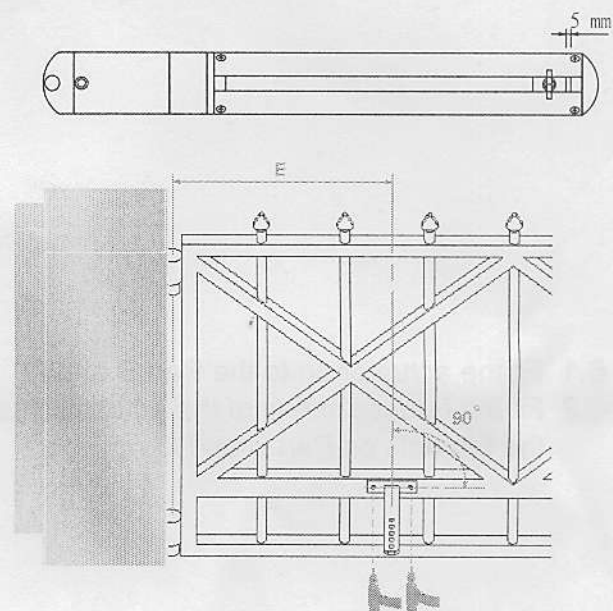

Recommended Installation Distances:

Open Range	A	E
90°	15.5cm	36.0cm
100°	14.0cm	37.5cm

3. Assembly the Axis for the motor end, Part C and the bolt together.

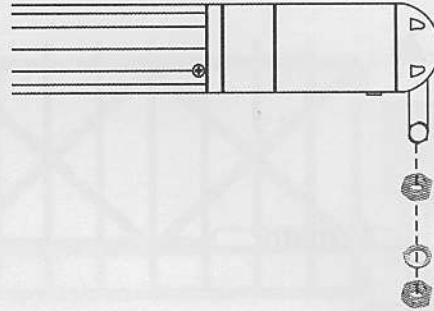

4. Put the Actuator onto Part B on the gate. Move Part C together with the Actuator on to pillar to make sure the gate is complete closed.

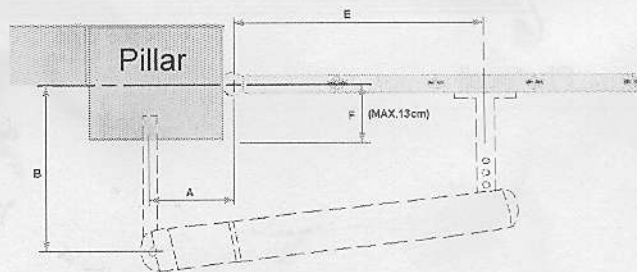

5. Draw a horizontal line from the center point of the Part B. Stick the Part C on the pillar and drill the two supposed holes. Fix the Part C on the pillar.

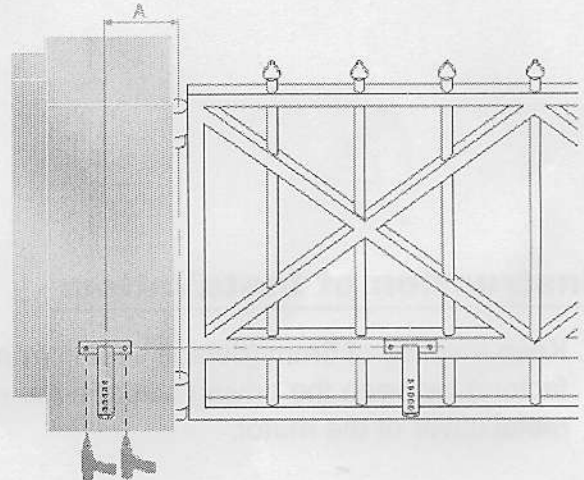

- 6.1 Fit the actuator on to the Part B and C.
6.2 Fit the release screw of the actuator into the 5th hole on Part B and C.

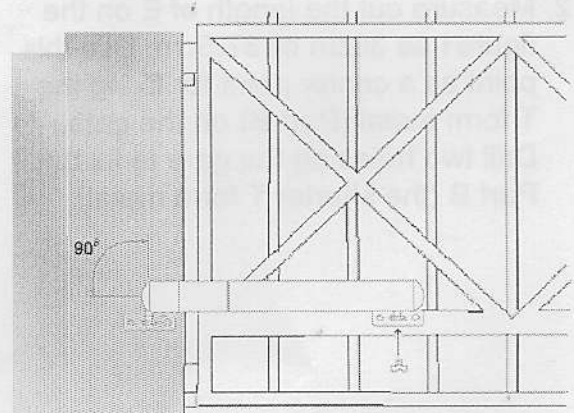

Connection Diagram

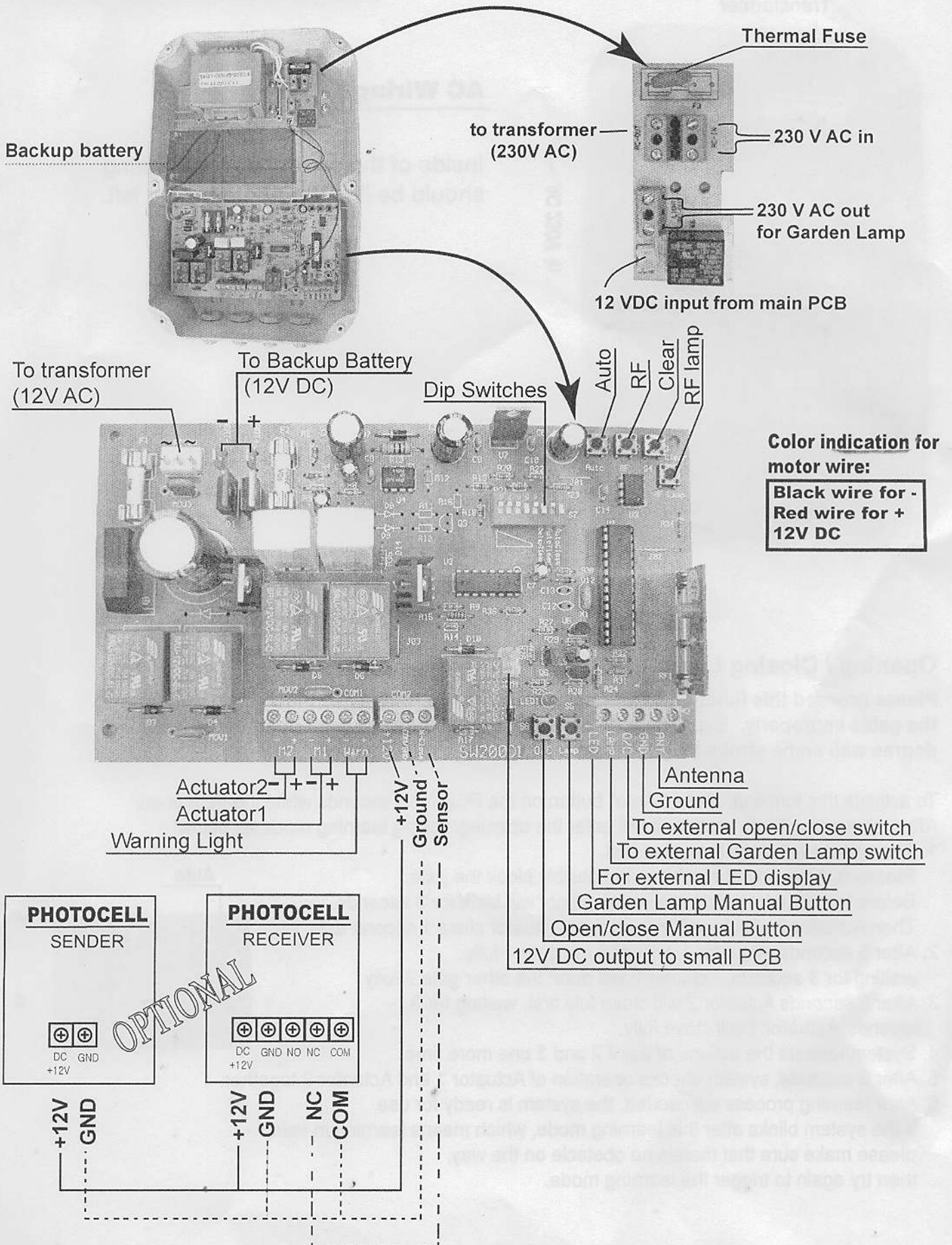

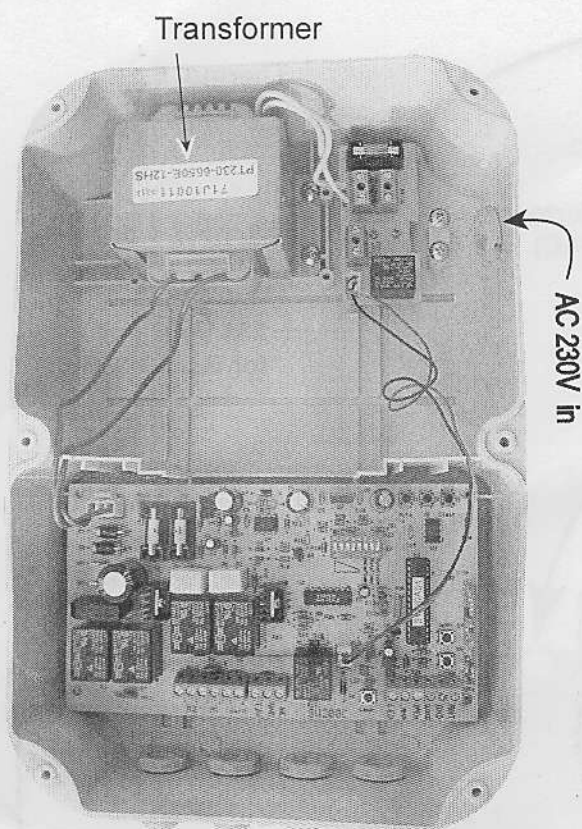

AC Wiring :

Inside of the control box, the wiring should be like the photo on the left.

Opening / Closing Learning:

Please proceed this function before using this product, otherwise the system will drive the gates improperly. E.g.: The gate can't close completely or can't open to the intended degree with some stroke length left unused.

To activate this function, press "Auto" button on the PCB for 3 seconds while the PCB is on. After release the "Auto" button, it will enter the opening/closing learning mode as below:

1. The system will close the gates first.
Please remove any obstacle could possibly block the gate.
Before the actuators start, the warning light will blink for 3 seconds.
Then Actuator 2 will close first, and then Actuator close 1 second later.
2. After 3 seconds, Actuator 1 will open the gate 1 fully, waiting for 3 seconds, Actuator 2 will open the other gate 2 fully.
3. After 3 seconds Actuator 2 will close fully first, waiting for 3 seconds, Actuator 1 will close fully.
4. System repeats the actions of point 2 and 3 one more time.
5. After 3 seconds, system checks operation of Actuator 1 and Actuator 2 together.
6. After learning process succeeded, the system is ready for use.

If the system blinks after this learning mode, which means learning in vain, please make sure that there's no obstacle on the way, then try again to trigger the learning mode.

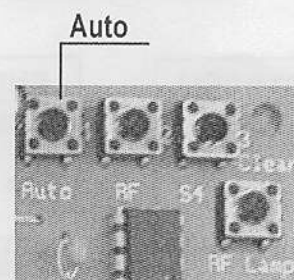

Remote Learning (activation of remote control for gate and lamp operation):

To activate the remote control service, please proceed the following steps:

A. RF gate learning: (for Open/Close the Gates)

1. Press "RF" key on the PCB for over 2 seconds while the PCB is on.
2. You'll see the LED light on (learning mode entered), please press any key on the remote control, LED will now blink for 3 times (learning succeeded) or light off after 10 seconds without blinking (learning failed, please try again the whole process).
3. Please repeat the step 1 and 2 to activate another remote control, otherwise the unlearnt remote control won't be recognized by the system.

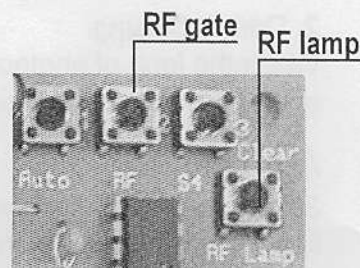

B. RF lamp learning:(for Turning On/Off the Garden Lamp)

Proceed with "RF lamp" key on the PCB and another key on the remote control as step 1~3 above.

Note: Up to 8 different RF remote control keys can be learnt for each function by this system (gates & Garden Lamp).

Remote Control:



Choose two of the four keys to proceed RF learning. The rest of the keys are available for other purposes such as Garage Door Opener.

The remote control has 4 keys on it, and choose two of them to proceed RF learning for one-key gate control and lamp control separately.

Operation (open, close and stop) by remote control:

The remote operation is very simple: one key press will open the gate, next press to stop, next to close the gate, next to stop...and so on.

When opening the gates:

1. Warning light will blink for 3 seconds, then Actuator 1 opens, 4 seconds later the Actuator 2 opens.
2. If the gate hits something, Actuators reverse for 3 seconds warning light blinks until next command received.

When closing the gates:

1. Warning light will blink for 3 seconds, then Actuator 2 closes, 4 seconds later the Actuator 1 closes.
2. If the gate hits something, Actuators reverse for 3 seconds warning light blinks until next command received.

Lamp control (on and off) by remote control:

Simply switch on and off the lamp by the key which had proceeded the "RF lamp" learning.

Remark: The gate operation works properly only after successful Opening/Closing Learning.

Photocell (Optional):

1. During Opening:

When the loop of photocells has been intercepted, system will:

- A. ignore, if the Actuator 2 has been activated. OR
- B. halt, if the Actuator 2 hasn't been activated yet.

2. During Closing:

When the loop of photocells has been intercepted, system will stop closing the gates and then open both gates simultaneously until the set position.

Auto close:

30 seconds or 60 seconds later (only when this function is enabled, depends on your setting of key 1 of dip switch), warning light will blink for 3 seconds then Actuator 2 closes, 4 seconds later Actuator 1 closes. When the process finished, warning light will be switched off.

Manual gates control on the PCB:

- 1. The operation is the same as remote: one key press will open the gate, next press to stop, next to close the gate, next to stop...and so on.
- 2. Optional handset or external wall button is available. (Connected to O/C & GND terminals)

Manual lamp on:

Simply switch on and off the lamp by the "Manual lamp on" key.

Clear RF memory:

Press "Clear" key on the PCB for over 2 seconds while the PCB is on.

You'll see the LED blinking for 2.5 seconds then the RF memory has been cleared.

Reset:

Press "Clear" key on the PCB and input AC power; keep pressing "Clear" key for over 2 seconds.

You'll see the LED blink for 2 seconds and light on for 3 seconds then light off.

Once the mentioned actions have been carried out, all RF data will be cleared.

Quick release:

Loosen the release screw.

Settings of Dip Switches:

The default setting of dip switches.

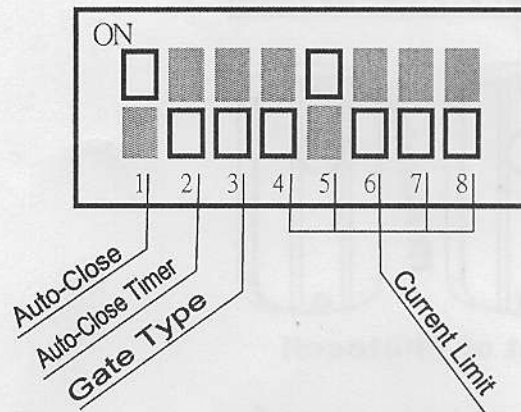

Key No.	Function	ON	OFF
1	Auto-Close	Yes	No
2	Auto-Close Timer	60 Sec	30 Sec
3	Gate Type	Heavy Gate	Light Gate
4~8	Current Limit	selected	unselected

Approx. current limit values for different dip switch setting:

switch 4	switch 5	switch 6	switch 7	switch 8	All off
1.0A	2.0A	3.0A	3.7A	4.5A	5.2A

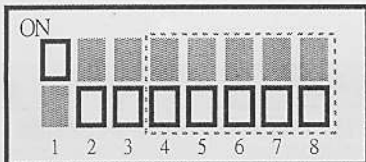

Maximum Current Limit (means also the worst sensibility, could shorten the life of motor, please try lower current limit first)

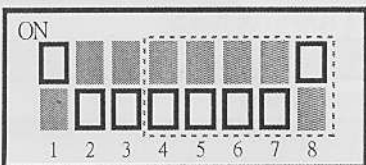

Second Highest Current Limit

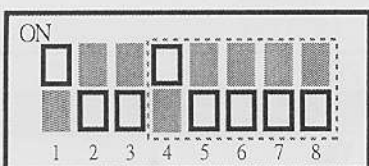

Minimum Current Limit

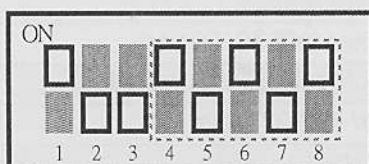

When user switches several switches on, for safety reason, system will choose the lowest (switch 4 instead of switch 6 or 8) current limit setting automatically.

Optional Accessories:

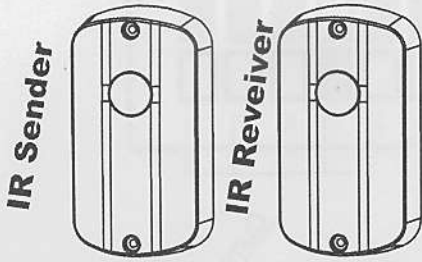

1 Set of Photocell

Operation of Photocell:

Select a proper installation site, where the sender and receiver can be along the same line and at the same height. Connect to the opener's PCB as wiring diagram above. Power on the system, try and see if it works properly by interrupting the IR between the sender and receiver for times. The relay in the receiver should respond accordingly while LED switches ON and OFF.

With photocell well installed, while it's triggered during opening the gates, the gates will ignore the interruption and open. While it's triggered during closing the gates, the gates will reverse for 3 seconds and stop and warning light will keep blinking until next command sent.

Specifications :

Model	SW200
Power Supply	230V AC \pm 10% 50Hz; 110V AC 60Hz available
Power for Motor	12 VDC
Maximum Gate Weight	200KGS (100+100KGS)
Maximum Gate Width	1.5M + 1.5M (10Feet)
Stroke Length	330mm (13in)
Drive	ACME
90° Operating Time	around 15 Sec
Open Range	110° Max.
Duty Cycle	20%
Operation Temperature	-20~65°C
Overload Protection	Yes
Backup Recharging Battery Foundation	Yes (Not Including Battery 12V,7AH)
Auto Gate Close	Adjustable timer (off/ 30/ 60sec)
Extension Terminal	Warning Light / Photocell / Back-up Battery
RF Carriage	315 MHz/ 433.92 MHz
Control Range	Approx. 30~50 Meters