

SAR-713

Seismic Alarm Recorder

User's Manual
(Version 1.07)



www.icpdas-usa.com

Warranty

All products manufactured by ICPDAS Inc. are warranted against defective materials for a period of one year from the date of delivery to the original purchaser.

Warning

ICPDAS Inc. assumes no liability for damages consequent to the use of this product. ICPDAS Inc. reserves the right to change this manual at any time without notice. The information furnished by ICPDAS Inc. is believed to be accurate and reliable. However, no responsibility is assumed by ICPDAS Inc. for its use, or for any infringements of patents or other rights of third parties resulting from its use.

Copyright

Copyright 2010 by ICPDAS Inc., LTD. All rights reserved worldwide.

Trademark

The user can use, modify and backup this software on a single machine. The user may not reproduce, transfer or distribute this software, or any copy, in whole or in part.

Table of Contents

1. Introduction :	6
1.1 Features :	7
1.2 Specification :	7
2. Application Architecture :	10
3. Wiring :	11
3.1 Information for Power LED	12
3.2 Information for 7-Segment LED Display	12
3.3 Digital Inputs (DIs) Configuration	13
3.4 Parameters for Autoexec.bat	13
3.5 DOs Wiring and Characteristics	14
3.6 DIs Wiring	14
4. Parameters Setting :	15
4.1 Initial Setting	15
4.2 Modbus Table :	16
4.3 Parameter Description	21
※ Addr 000 : NTP / TCP Server Connection Flag	21
※ Addr 001 : Real-Time X-Axis Acceleration	21
※ Addr 002 : Real-Time Y-Axis Acceleration	21
※ Addr 003 : Real-Time Z-Axis Acceleration	21
※ Addr 004 : Real-Time Vector Acceleration	22
※ Addr 005 : X-Axis Offset	22
※ Addr 006 : Y-Axis Offset	22
※ Addr 007 : Z-Axis Offset	22
※ Addr 008 : The Max Acceleratoin in Earthquake	22
※ Addr 009 : Real-Time earthquake Intensity	23
※ Addr 010 : Max Intensity of the last Earthquake	23
※ Addr 011 : Earthquake Event Flag	23
※ Addr 012 : LTA Ready Flag	23
※ Addr 013 : EEPROM Data Reocrd Flag	24
※ Addr 014 : Time Zone	24
※ Addr 015 : STA Duration	24
※ Addr 016 : LTA Duration	25
※ Addr 017 : Earthquake Thresold in STA/LTA	25
※ Addr 018 : Operation Mode Setting	25
※ Addr 019 : DI / DO Status	27

※ Addr 020 : Earthquake Event Duration.....	27
※ Addr 021 : Earthquake Event Remaining Time	28
※ Addr 022 : Zero Offset Sample Number.....	28
※ Addr 023 / 024 : DO0/ DO1 Trig Value.....	28
※ Addr 025 : Trig NTP Function.....	29
※ Addr 026 : NTP Update Time Period.....	29
※ Addr 027 : The Activated NTP Server No.	29
※ Addr 028 : Real-Time STA / LTA.....	29
※ Addr 029 : Max Acceleration of X-Axis in Earthquake Event.....	29
※ Addr 030 : Max Acceleration of Y-Axis in Earthquake Event.....	29
※ Addr 031 : Max Acceleration of Z-Axis in Earthquake Event.....	29
※ Addr 032 : X-Axis Acceleration of Max Vector in Earthquake ...	30
※ Addr 033 : Y-Axis Acceleration of Max Vector in Earthquake ...	30
※ Addr 034 : Z-Axis Acceleration of Max Vector in Earthquake....	30
※ Addr 035 ~038 : Data File Function of Earthquake Event	30
※ Addr 039 : Streaming Data Control	31
※ Addr 040 : Max STA/LTA in Earthquake Event	32
※ Addr 041 ~ 046 : Earthquake Event Time	32
※ Addr 047 ~ 052 : System Date / Time Information	33
※ Addr 053 ~ 058 : System Date / Time Setting	33
※ Addr 059 ~ 062 : IP Address of NTP Server 2 Setting	33
※ Addr 063 / 064 : Pre-Time / Post-Time Setting.....	33
※ Addr 065 / 066 : Counts and Total Counts of Earthquake Event33	
※ Addr 067 ~ 069 : Pulse Filter Value of 3-Axis Acceleration	34
※ Addr 070 : Pulse Filter Total Count of 3-Axis	34
※ Addr 071 ~ 074 : IP Address of NTP Server 1 Setting	34
※ Addr 075 : System Time Information - Week	34
※ Addr 076 ~ 079 : Host MB/TCP Server IP Address Setting.....	34
※ Addr 080 ~ 091 : SAR-713 Network Address Setting.....	35
※ Addr 092 : Available MB/TCP Connections for Host	35
※ Addr 093 : MB/TCP Client Update Period.....	35
※ Addr 094 : Modbus TCP/RTU Server Station No. Setting	35
※ Addr 095 : Debug Message Enable Flag	35
※ Addr 096 : Remaining Time before Earthquake Detection	35
※ Addr 097 : DHCP Client Function Status	36
※ Addr 098 : Axis-Mapping Setting.....	36
※ Addr 099 : SAR-713 Firmware Version	36
※ Addr 100 : SAR-713 Machine Serial Number.....	36

※ Addr 101 ~ 108 : FilterIP Range Setting.....	36
※ Addr 109 : Extended Intensity Standard Option	37
※ Addr 110 : Extended Intensity Calculation Mode Option.....	37
※ Addr 111 : Intensity Degree Value	38
※ Addr 112 : Extra Function Trigger	38
4.4. Modbus Function.....	39
4.5 SAR-713 Sequence.....	40
4.5.1. Boot Sequence.....	40
4.5.2. Earthquake Event Sequence.....	40
5. Software Utility :	41
5.1 Connection Function	41
5.2 Module Configuration Function	44
5.3 TCP1500 Function	46
5.4 EQFile_Info Function.....	52
5.5 Firmware Update.....	54
5.6 Stream Data	57
5.7 EQVoice File	59
6. TCP1500 Function :	61
7. Factory Default Value :	62
7.1 Factory Default Value Table.....	62
8. Direction Definition of X, Y, Z Axis :	65
9. FAQ :	66
9.1 How to scan all SAR-713 modules in LAN ?	66
9.2 Trend Update Pause Problem of SAR-713 Utility.....	69
10. Version	70
Appendix 1: Earthquake Intensity Table of Taiwan	71
Appendix 2: Earthquake Intensity Table of China	72
Appendix 3: Modified Mercalli Intensity Scale	73
Appendix 4: JMA Intensity Scale	74
Appendix 5 : Unit Conversion	75

1. Introduction :

SAR-713 is an advanced technology seismic alarm recorder provided by ICP DAS with a tri-axial MEMS accelerometer and acquires vibration signal by 100Hz sampling rate. It can be used to establish a complete earthquake warning system to prevent any further significant damages caused by.

SAR-713 adopts STA/LTA algorithm and supports dynamic zero offset calibration to detect earthquake. It is not only a seismic switch inclusive of 2 digital outputs for the security of facilities or staffs but also an earthquake data recorder for research analysis. It equips LED display which can real time show the maximum intensity according to CWB (Central Weather Bureau, Taiwan) or GB/T 17742-2008 (China) earthquake intensity standard, maximum vector, instant tri-axial acceleration, etc.

SAR-713 supports NTP (Network Time Protocol) to keep internal clock on time and NTP server backup function for reliability of time accuracy. SAR-713 also supports host IP filter function to promote the security of network access.

SAR-713 offers both MB/TCP and MB/RTU server for easily connection to host PC, PLC, HMI or SCADA. The connection number of MB/TCP host can be up to 10 simultaneously. It also provides active connection ability to MB/TCP server of host PC which is useful to deploy at environment without real IP.

1.1 Features :

- RoHS Design.
- Provide two digital outputs individually to protect crucial facilities.
- Support earthquake data file record function.
- Support NTP (Network Time Protocol) for time calibration to keep SAR-713 clock on time.
- Support NTP backup server to promote time calibration reliability.
- Support IP filter function to promote the security of network access.
- Adopt STA/LTA algorithm and dynamic zero offset to detect earthquake.
- Support DHCP function
- Support MB/TCP and MB/RTU server function.
- Support MB/TCP client to connect to host MB/TCP server automatically.
- Support up to 10 MB/TCP client number simultaneously.
- Support Taiwan / Japan / China / Modified Mercalli Intensity standard.
- Support module installation horizontally or vertically.
- Support firmware update via COM or Ethernet.
- Provide utility tool for real-time tri-axial acceleration trend and module setting.
- Watchdog inside.

1.2 Specification :

Items	SAR-713
Accelerometer	
Type	Tri-axial MEMS
Range	±2g (X, Y Axes) 、 +1g/-3g (Z Axis)
Frequency Response	0 ~ 40 Hz
Shock	500g / 0.5 ms 3000g / 0.1 ms
Digitizer	
ADC Resolution	12 bit
Digital Resolution	< 0.001 g
Earthquake Gauge	
Algorithm	STA/LTA
STA Setting Range	0.01 ~ 60 Sec.

LTA Setting Range	0.01 ~ 60 Sec.
Offset Period	0.01 ~ 655 Sec.
Event Duration Time	0.01 ~ 60 Sec.
Intensity Standard	Support Taiwan / Japan / China / Modified Mercalli Intensity standard.
Earthquake File Record	
Alarm Time Record Range	0.01 ~ 60 Sec.
Pre-Time Record Range	0.01 ~ 10 Sec.
Post-Time Record Range	0.01 ~ 10 Sec.
Switch Setpoints	
Digital Output Numbers	2
Setpoint Range	2 ~ 1960 gal (cm/s ²)
Contact Type	Normal Open
Contact Capacity	0.6A DC
Hold-On Time	Same as Event or Duration Time
Modbus Comm.	
Modbus/TCP	Most 10 Host Simultaneously
Modbus/RTU	Default:1 (settable) ; Format:115200,N,8,1
Modbus Function Code	Function Code : 1, 2, 3, 6, 16
Modbus Variables Address	000 ~ 108
LED Display	
5-Digit 7 Segment LED Display	Display Module and Earthquake Information
System LED Indicator	Display Module Power and Comm. Status
Operating Environment	
Operating Temperature	-25°C ~ +75°C
Storage Temperature	-40°C ~ +80°C
Relative Humidity	5 ~ 90% RH, non-condensing
Dimensions	
W x H x D	102 mm x 123 mm x 28 mm
Weight	285g (Without Power and Cable)
Power	
Protection	Power reverse polarity protection

Frame Ground for ESD Protection	Yes
Required Supply Voltage	+10 ~ +30 VDC (non-regulated)
Power Consumption	3.5 W

2. Application Architecture :

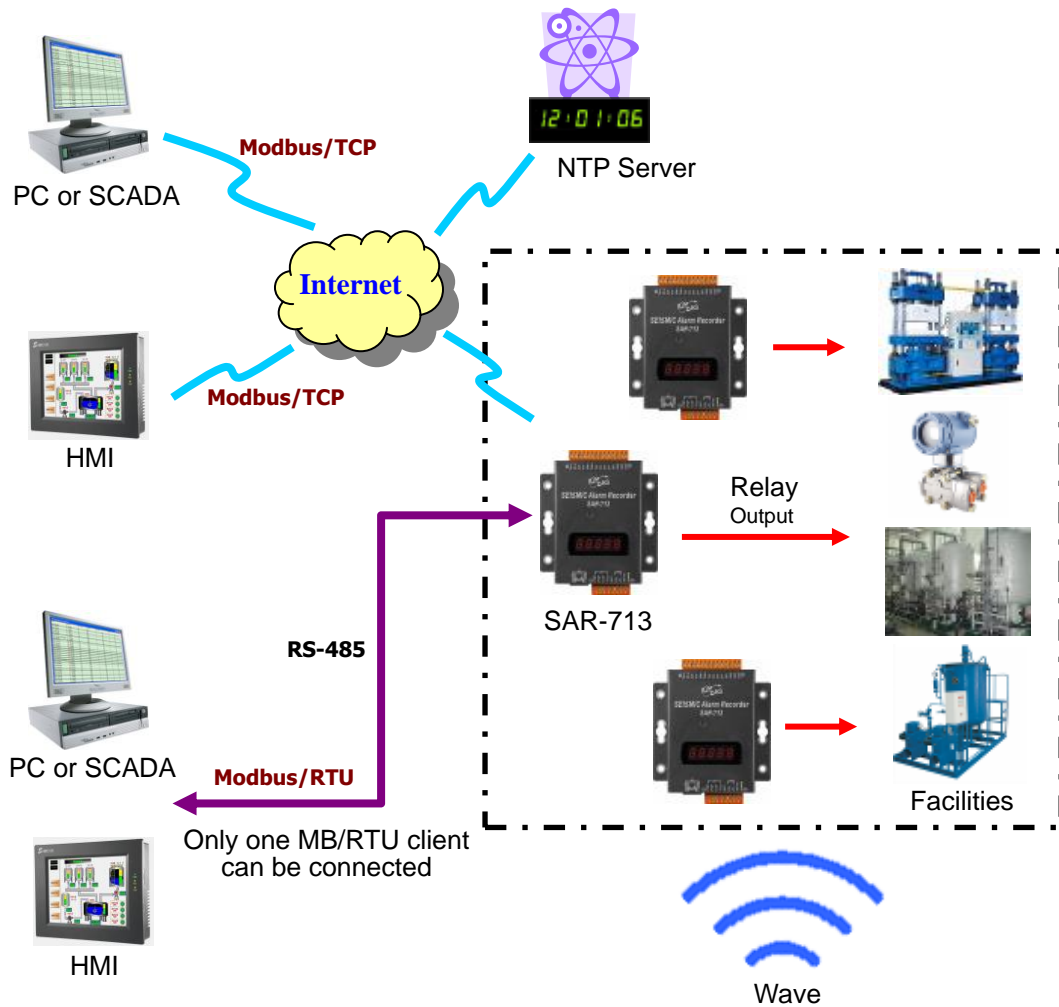

3. Wiring :

Pins	Description
GND	Power Ground
+Vs	Power Input : 10~30VDC 300mA
D2-	RS-485 D- of COM2 (Modbus RTU)
D2+	RS-485 D+ of COM2 (Modbus RTU)
INIT*	Update firmware (No use when operaton)
TXD1	TX of COM1 (Debug Port)
RXD1	RX of COM1 (Debug Port)
RTS1	RTS of COM1
CTS1	CTS of COM1
E1	Modbus TCP (10 / 100M Ethernet Port)
DO0+	Relay Output 0+ (PhotoMOS Relay, Form A) Normal Open , 0.6A/60VDC
DO0-	Relay Output 0- (PhotoMOS Relay, Form A) Normal Open , 0.6A/60VDC
DO1+	Relay Output 1+ (PhotoMOS Relay, Form A) Normal Open , 0.6A/60VDC
DO1-	Relay Output 1- (PhotoMOS Relay, Form A) Normal Open , 0.6A/60VDC
DI0	Digital Input 0 (Show earthquake info when grounding.)
DI1	Digital Input 1 (Recover to factory setting when DI-1 is grounding for 3 second continuously.)
DI2	Digital Input 2 (Reserved)
DI3	Digital Input 3 (Reserved)

3.1 Information for Power LED

When SAR-713 powers on, the PWR LED will be on always. When Modbus communication (including MB/TCP and MB/RTU) starts, the PWR LED will flash. If Modbus communication stopped, then the PWR LED will be on always.

3.2 Information for 7-Segment LED Display

Normal Status :

Display the below system information in order (When DI 0 isn't grounding)

(1) - - 1 - - : Show current IP Address of SAR-713 and format is as below.

1. 192 (IP1)
2. 168 (IP2)
3. 255 (IP3)
4. 1 (IP4)

(2) - - 2 - - : Show current date and format is as below.

- 2010- (Year)
10-13 (Month-Day)

(3) - - 3 - - : Show current time and format is as below.

- 12-01 (Hour-Minute)
01.44 (Minute-Second)

(4) - - 4 - - : Show earthquake event number and format is as below.

- 1.0001 (Event number in this boot up => once)
2.0010 (Event total number => ten times)

Earthquake Detected :

Display the below information in order :

(1) Intensity Standard :

- [1] "-C01-" : CWB scale (Taiwan)
- [2] "-C02-" : GB/T 17742-2008 scale (China)
- [3] "-C03-" : [Modified Mercalli scale. \(America\) => FW_v1.04](#)
- [4] "-C04-" : [JMA scale \(Japan\) => FW_v1.04](#)

(2) Max Intensity : (Format : XXXXX)

- [1] Taiwan(CWB) : Range from 0 to 7 (Ex: 66666 is intensity-6)
- [2] China(GB/T) : Range from 0 to 11 (Ex: AAAAAA is intensity-10)
- [3] [Mercalli](#) : Range from 0 to 11 (Ex: A0001 is intensity-11)
- [4] [Japan\(JMA\)](#) : Range from 0 to 9 (Ex: 55555 is intensity-5 lower)
(Ex: 66666 is intensity-5 upper)

(3) Max Acceleration : (Unit : gal)

[1] Taiwan(CWB) : z-axis or tri-axial vector or XY-axial vector.

[2] China(GB/T) : horizontal axis (X and Y) vector.

[3] Mercalli : z-axis or tri-axial vector or XY-axial vector.

[4] Japan(JMA) : z-axis or tri-axial vector or XY-axial vector.

3.3 Digital Inputs (DIs) Configuration

[1] Display the last earthquake information : (DI-0)

When **DI-0** is grounding, the LED display will show the last earthquake information in order and the format is as below.

(1) -C0x- : Zone ("-C01-" : Taiwan ; "-C02-" : China ;
"-C03-" : America ; "-C04-" : Japan)

(2) YYYY- : Year

(3) MM-DD : Month-Day

(4) hh-mm : Hour-Minute

(5) mm -ss : Minute-Second

(6) XXXXX : Max Intensity

(7) AA.AA : Taiwan: Max Acceleration(gal);

China: Max Horizontal Acceleration(gal)

If no any earthquake event happened after boot up, then the LED display will show "0.0.0.0.0" message.

[Note]

(1) DI-0 will work when earthquake doesn't happen.

[2] Recover to factory setting : (DI-1)

When **DI-1** is grounding for 3 seconds continuously, SAR-713 will execute the factory default value recovery and then reboots.

3.4 Parameters for Autoexec.bat

There is just one parameter is supported by SAR-713 as below.

[Parameter 1] : DHCP Client Enable

Ex1 : SR713_10.exe => No any other extra function will be executed when SAR-713 boots up.

Ex2 : SR713_10.exe Y => DHCP client function will be executed when SAR-713 boots up.

Ex3 : SR713_10.exe **/W300** => In 300 seconds, if there is no any TCP

communication in the socket, then SAR-713 will disconnect the socket automatically. It can solve the TCP connection problem.

[Note]

(1) When DHCP client function executes failed, SAR-713 will adopt the original local IP address for default.

3.5 DOs Wiring and Characteristics

DO is acted just like a switch with **contact capacity as 60V 0.6A**. Please refer to the below wiring diagram.

Output Type	Readback as 1	Readback as 0
	Relay On	Relay Off
From A Relay Contact		

3.6 DIs Wiring

Please refer to the below DI wiring diagram.

Input Type	ON State DI value as 1	OFF State DI value as 0
Relay Contact		
TTL/CMOS Logic		
Open Collector		

4. Parameters Setting :

The parameters of SAR-713 have been set optimally for factory default. However, due to the different installation of location and signal noise, some adjustments for the parameters are necessary. In section 4.1, some basic and important parameters are described. In section 4.2, it is the Modbus table for all parameters. In section 4.3, it is the detailed description for all parameters.

4.1 Initial Setting :

[1] IP/Mask/Gateway setting of SAR-713 : (Addr: 080~091)

Users need to set the IP/Mask/Gateway of SAR-713 according to the current network IP address range (Factory default value refers to chapter 7). If users want to use DHCP client function, please refer to section 3.4.

[2] Installation of SAR-713 : (Addr: 098)

When users install SAR-713 horizontally, then the value of MB addr 098 should be set 0. If SAR-713 is installed vertically, then it should be set 1. If the value of MB addr 98 is set wrong, then the tri-axial direction will be wrong. After set the value of MB addr 098 correctly, the schematic diagram of the tri-axial direction refers to chapter 8.

[3] Operation mode setting of SAR-713 : (Addr: 018, 109, 110)

The OP_Mode parameter must be set according to the application environment. The detailed description refers to MB addr 018. In FW_v1.04 or newer, add the “Extended Intensity Standard Option” in MB addr 109 and the “Extended Intensity Calculation Mode Option” in MB addr 110.

[4] Earthquake function setting :

The related parameters need to be set according the application devices and environment and described as below.

- (1) “STA Time” / “LTA Time” / “STA/LTA Level” (Addr: 015~017)
- (2) Earthquake Alarm Time (Addr: 020)
- (3) Earthquake Pre-/Post- Record Time (Addr: 063~064)
- (4) DO0/1 Trigger Level (Addr: 023~024)

=> Factory default value refers to chapter 7.

[Note]

1. For earthquake testing, the **adjustment principle of the STA/LTA (Addr 017)** is as below.

(1) If the **fake vibration** test failed :

Adjust the STA/LTA (addr 017) value to be larger than the value of "addr 040".

(The "addr 040" means the max value of STA/LTA in this earthquake)

(2) If the **real earthquake** can't be detected :

Adjust the STA/LTA (addr 017) value" to be smaller.

2. For earthquake testing, the **adjustment principle of the DO0 (Addr 023) and DO1 (Addr 024)** is as below.

(1) If the real earthquake is detected, but DO0 or DO1 not triggered :

Adjust the "addr 023" and "addr 024" value" to be smaller than the value of "addr 008".

(The "addr 008" means the max acceleration value in this earthquake)

[4] Time calibration Setting :

This value of MB addr 014 needs to be set according to practical areas (Like: Taiwan is 8). Then set NTP Server IP in MB addr 071~074 and 059~063. At last, set the bit-4 of MB addr 018 to be 1 to enable NTP function.

4.2 Modbus Table :

The Modbus registers from 40001 ~ 40111 are used by SAR-713, 40112 ~ are reserved.

In the below table, the "Addr Offset" value is the offset from 40001. In R/W field · R means "Read Only", W means "Write Only" and RW means "Readable and Writable". "Label" is the variable name and "Description" is the function description. (EQ means Earthquake)

SAR-713 Modbus Table (40XXX)				
Addr Offset (DEC)	Addr Offset (HEX)	R/W	Label	Description
000	0x00	R	SvrConn_Flag	NTP/TCP Server Connection Flag

SAR-713 Modbus Table (40XXX)				
001	0x01	R	X_Acc	Real-Time X-axis Acceleration
002	0x02	R	Y_Acc	Real-Time Y-axis Acceleration
003	0x03	R	Z_Acc	Real-Time Z-axis Acceleration
004	0x04	R	Vec_Acc	Real-Time 3-axial Vector Acc.
005	0x05	R	X_Acc_Offset	X-axis Offset
006	0x06	R	Y_Acc_Offset	Y-axis Offset
007	0x07	R	Z_Acc_Offset	Z-axis Offset
008	0x08	R	Acc_Max	Max Acceleration in Earthquake
009	0x09	R	Intensity_Now	Real-Time EQ Intensity
010	0x0A	R	Intensity_Max	Max Intensity in Earthquake
011	0x0B	R	EQ_Event_Flag	Earthquake Event Flag
012	0x0C	R	LTA_Flag	LTA Ready Flag (1: Ready)
013	0x0D	W	Data_Rec_Flag	EEPROM Data Record Flag
014	0x0E	RW	Time_Zone_Diff	GMT Time Zone (Taipei: 8)
015	0x0F	RW	STA_Time	STA Duration (Unit: 10ms)
016	0x10	RW	LTA_Time	LTA Duration (Unit: 10ms)
017	0x11	RW	STA/LTA_Lev	Earthquake Threshold in STA/LTA
018	0x12	RW	OP_Mode	Operation Mode
019	0x13	R	DIO_Status	DI and DO Status
020	0x14	RW	EQ_Event_Time	Earthquake Event Duration
021	0x15	R	EQ_Remain_Time	Earthquake Event Remain Time
022	0x16	RW	Zero_Offset_Number	Zero Offset Sample Number
023	0x17	RW	DO0_Trig_Value	DO0 Trig Value
024	0x18	RW	DO1_Trig_Value	DO1 Trig Value
025	0x19	W	NTP_Trig	Trig NTP function
026	0x1A	RW	NTP_Update_Time	NTP Update Time Period
027	0x1B	RW	NTP_Server_No	Activated NTP Server No.
028	0x1C	R	STA/LTA	Real-Time STA/LTA
029	0x1D	R	EQ_X_Acc_Max	Max X-Axis Acceleration in EQ
030	0x1E	R	EQ_Y_Acc_Max	Max Y-Axis Acceleration in EQ
031	0x1F	R	EQ_Z_Acc_Max	Max Z-Axis Acceleration in EQ
032	0x20	R	EQ_Vec_X_Max	X-Axis Acceleration of Max Vector in EQ

SAR-713 Modbus Table (40XXX)				
033	0x21	R	EQ_Vec_Y_Max	Y-Axis Acceleration of Max Vector in EQ
034	0x22	R	EQ_Vec_Z_Max	Z-Axis Acceleration of Max Vector in EQ
035	0x23	RW	EQ_Data_RecFlag	EQ Data File Record Flag
036	0x24	RW	EQ_Data_BlkJNo	EQ Data File Block No.
037	0x25	R	EQ_BlkJFreeSize	Remain Space of EQ Data Block
038	0x26	RW	EQ_BlkJFullFunc	Data Block Full Function
039	0x27	RW	Stream_Data_Ctrl	Streaming Data Control
040	0x28	R	EQ_STA/LTA_Max	Max STA/LTA in Earthquake
041	0x29	R	EQ_Year	Earthquake Time - Year
042	0x2A	R	EQ_Month	Earthquake Time - Month
043	0x2B	R	EQ_Day	Earthquake Time - Day
044	0x2C	R	EQ_Hour	Earthquake Time - Hour
045	0x2D	R	EQ_Minute	Earthquake Time - Minute
046	0x2E	R	EQ_Second	Earthquake Time - Second
047	0x2F	R	Sys_Year	System Time - Year
048	0x30	R	Sys_Month	System Time - Month
049	0x31	R	Sys_Day	System Time - Day
050	0x32	R	Sys_Hour	System Time - Hour
051	0x33	R	Sys_Minute	System Time - Minute
052	0x34	R	Sys_Second	System Time - Second
053	0x35	RW	Set_Year	Set System Time - Year
054	0x36	RW	Set_Month	Set System Time - Month
055	0x37	RW	Set_Day	Set System Time - Day
056	0x38	RW	Set_Hour	Set System Time - Hour
057	0x39	RW	Set_Minute	Set System Time - Minute
058	0x3A	RW	Set_Second	Set System Time - Second
059	0x3B	RW	NTPSvr2_IP1	NTP Server2 IP Address 1
060	0x3C	RW	NTPSvr2_IP2	NTP Server2 IP Address 2
061	0x3D	RW	NTPSvr2_IP3	NTP Server2 IP Address 3
062	0x3E	RW	NTPSvr2_IP4	NTP Server2 IP Address 4
063	0x3F	RW	Pre-EvtTime	Pre-Time for EQ Event Record

SAR-713 Modbus Table (40XXX)				
064	0x40	RW	Post-EvtTime	Post-Time for EQ Event Record
065	0x41	R	EQ_Cnt	EQ Count for every boot up
066	0x42	RW	EQ_TotalCnt	EQ Total Count
067	0x43	RW	X_Pulse_Filter	X-axis Pulse Filter Value
068	0x44	RW	Y_Pulse_Filter	Y-axis Pulse Filter Value
069	0x45	RW	Z_Pulse_Filter	Z-axis Pulse Filter Value
070	0x46	RW	Pulse_Filter_Cnt	Pulse Filter Count of 3-axis
071	0x47	RW	NTPSvr_IP1	NTP Server1 IP Address 1
072	0x48	RW	NTPSvr_IP2	NTP Server1 IP Address 2
073	0x49	RW	NTPSvr_IP3	NTP Server1 IP Address 3
074	0x4A	RW	NTPSvr_IP4	NTP Server1 IP Address 4
075	0x4B	R	Sys_Week	System Time - Week
076	0x4C	RW	TCPSvr_IP1	MB/TCP Server IP Address 1
077	0x4D	RW	TCPSvr_IP2	MB/TCP Server IP Address 2
078	0x4E	RW	TCPSvr_IP3	MB/TCP Server IP Address 3
079	0x4F	RW	TCPSvr_IP4	MB/TCP Server IP Address 4
080	0x50	RW	IP1	SAR-713 IP Address 1
081	0x51	RW	IP2	SAR-713 IP Address 2
082	0x52	RW	IP3	SAR-713 IP Address 3
083	0x53	RW	IP4	SAR-713 IP Address 4
084	0x54	RW	Mask1	SAR-713 Subnet Mask 1
085	0x55	RW	Mask2	SAR-713 Subnet Mask 2
086	0x56	RW	Mask3	SAR-713 Subnet Mask 3
087	0x57	RW	Mask4	SAR-713 Subnet Mask 4
088	0x58	RW	Gateway1	SAR-713 Gateway 1
089	0x59	RW	Gateway2	SAR-713 Gateway 2
090	0x5A	RW	Gateway3	SAR-713 Gateway 3
091	0x5B	RW	Gateway4	SAR-713 Gateway 4
092	0x5C	R	Sck_Remain	Available Connections for Host
093	0x5D	RW	MBTCP_Cli_Period	MB/TCP Client Update Period
094	0x5E	RW	MB/TCP/RTU_Server_Station_No	MB/TCP/RTU Server Station No.
095	0x5F	RW	Debug_Msg_Flag	Debug Message Enable Flag

SAR-713 Modbus Table (40XXX)				
096	0x60	R	EQ_Detection_Remain_Time	Remain Time before EQ Detection
097	0x61	R	DHCP_Status	DHCP Client Function Status
098	0x62	RW	Axis_Mapping	Installation Mode Setting 0:Horizontal; 1:Vertical
099	0x63	R	FW_Ver	SAR-713 Firmware Version
100	0x64	RW	Serial_No	SAR-713 Serial Number
101	0x65	RW	Filter_StartIP1	SAR-713 Filter Start IP Addr 1
102	0x66	RW	Filter_StartIP2	SAR-713 Filter Start IP Addr 2
103	0x67	RW	Filter_StartIP3	SAR-713 Filter Start IP Addr 3
104	0x68	RW	Filter_StartIP4	SAR-713 Filter Start IP Addr 4
105	0x69	RW	Filter_EndIP1	SAR-713 Filter End IP Addr 1
106	0x6A	RW	Filter_EndIP2	SAR-713 Filter End IP Addr 2
107	0x6B	RW	Filter_EndIP3	SAR-713 Filter End IP Addr 3
108	0x6C	RW	Filter_EndIP4	SAR-713 Filter End IP Addr 4
109	0x6D	R/W	Intensity_StdOpt	Extended Intensity Standard Option
110	0x6E	R/W	Intensity_CalOpt	Extended Intensity Calculation Mode Option
111	0x6F	R	Intensity_DegVal	Intensity Degree Value
112	0x70	RW	ExtFunc_Trig	Extra Function Trigger

4.3 Parameter Description

※ Addr 000 : NTP / TCP Server Connection Flag

[bit 0]

0: SAR-713 doesn't synchronize with NTP server.

1: SAR-713 has synchronized with NTP server.

If NTP function is enabled, when SAR-713 boots up, SAR-713 will try to synchronize with NTP server immediately and then every 5 minutes will try again. This time period can be modified via MB addr 026.

If SAR-713 tries to synchronize with NTP server 1 three times continuously and all failed, SAR-713 will try to synchronize with NTP server 2 automatically. Regarding the IP address of NTP server 1 and 2, please refer to MB addr 071 ~ 074 and 059 ~ 062.

[bit 1]

0: No connection between SAR-713 and host MB/TCP server.

1: Connection between SAR-713 and host MB/TCP server has been established.

Regarding the IP address of host MB/TCP server, please refer to MB addr 076~079.

[Note]

1. NTP Server function is decided by the bit 4 of MB addr 018 (op_mode) and TCP Server function is decided by the bit 3 of MB addr 018.

※ Addr 001 : Real-Time X-Axis Acceleration

Real-time X axis acceleration in count unit, 1mg is equal to 16.384 counts.

※ Addr 002 : Real-Time Y-Axis Acceleration

Real-time Y axis acceleration in count unit, 1mg is equal to 16.384 counts.

※ Addr 003 : Real-Time Z-Axis Acceleration

Real-time Z axis acceleration in count unit, 1mg is equal to 16.384 counts.

※ Addr 004 : Real-Time Vector Acceleration

Real-time vector acceleration in count unit, 1mg is equal to 16.384 counts. The equation of vector is as below.

$$Vector = \sqrt{X^2 + Y^2 + Z^2}$$

※ Addr 005 : X-Axis Offset

This address stores X-axis offset value in count unit which is calculated by SAR-713 automatically. (Owing to the output of accelerometer at zero acceleration will be affected by installation location or other factors). SAR-713 supports dynamic zero offset function.

※ Addr 006 : Y-Axis Offset

This address stores Y-axis offset value in count unit which is calculated by SAR-713 automatically. (Owing to the output of accelerometer at zero acceleration will be affected by installation location or other factors). SAR-713 supports dynamic zero offset function.

※ Addr 007 : Z-Axis Offset

This address stores Z-axis offset value in count unit which is calculated by SAR-713 automatically. (Owing to the output of accelerometer at zero acceleration will be affected by installation location or other factors). SAR-713 supports dynamic zero offset function.

※ Addr 008 : The Max Acceleratoin in Earthquake

This address stores the [absolute maximum acceleration in 0.1 gal unit](#). This value will be updated until next earthquake happened or cleared when SAR-713 gets into initialization mode. The meaning of this value will be decided by bit 0 and bit 2 of MB addr 018 and MB addr 110. It may be one of max acceleration of z axis or 3-axis or horizontal axis.

※ **Addr 009 : Real-Time earthquake Intensity**

This address stores the real-time intensity and the intensity standard is according to bit 0 of MB addr 018 to decide CWB standard (Central Weather Bureau, Taiwan) or GB/T 17742-2008 standard (China). About the intensity standard, please refer to the appendix 1 for Taiwan and appendix 2 for China.

CWB Standard (Taiwan) :

If CWB standard is adopted, the bit 2 of MB addr 18 is used to decide the intensity calculated by [the acceleration of 3-axis vector or z-axis](#).

GB/T 17742-2008 Standard (China) :

If GB/T 17742-2008 standard is adopted, the intensity will be calculated by [horizontal acceleration](#) (horizontal vector including X and Y axis acceleration). Owing to no definition for intensity less than 4, so the below levels are used by SAR-713 to determine intensity.

1 : $\leq 0.8 \text{ cm/sec}^2$

2 : $\leq 2.2 \text{ cm/sec}^2$

3 : $\leq 8.0 \text{ cm/sec}^2$

4 : $\leq 22.0 \text{ cm/sec}^2$

※ **Addr 010 : Max Intensity of the last Earthquake**

This address stores the max intensity of the last earthquake and the intensity standard is according to “bit 0 of MB addr 018” and “MB addr 109” to decide CWB Intensity (Central Weather Bureau, **Taiwan**) or GB/T 17742-2008 Intensity (**China**) or Modified Mercalli Intensity. About the intensity standard, please refer to the appendix 1 for Taiwan, appendix 2 for China and appendix 3 for the Modified Mercalli.

※ **Addr 011 : Earthquake Event Flag**

The value will be 1 when SAR-713 detects earthquake. 0 when there is no earthquake detected.

※ **Addr 012 : LTA Ready Flag**

LTA means Long Time Average which is the acceleration average in

specified long time period. The other parameter is STA which means Short Time Average. SAR-713 adopts STA/LTA algorithm for earthquake detection. When the value of STA (MB addr 15) divided LTA (MB addr 16) is greater than the level of STA/LTA (MB addr 17), it means earthquake happened. When SAR-713 boots up, it needs enough time (decided by MB addr 16 - LTA) to acquire the enough data for LTA. If LTA Ready Flag is 1, it means SAR-713 is ready for earthquake detection.

※ **Addr 013 : EEPROM Data Reocrd Flag**

When the parameters of SAR-713 are modified, users need to write the corresponding value to trig data recorded in EEPROM. Then the parameters will be adopted whenever SAR-713 reboots.

- (1) Write **1** : Valid for the below MB addr.
005~007, 014~018, 020, 022~024, 026~027, 039, 035~036,
063~064, 066~069, 093~094, 098, 100, 109~110.
- (2) Write **2** : Valid for MB addr 080~091 used to update IP, Mask and Gateway of SAR-713.
- (3) Write **3** : Valid for MB addr 053~058 used to update RTC time of SAR-713.
- (4) Write **4** : Valid for MB addr 071~074 and 059~062 used to update NTP Server IP address of SAR-713.
- (5) Write **5** : Valid for MB addr 076~079 used to update Host MB/TCP Server IP address of SAR-713.
- (6) Write **6** : Recover to Factory default value of SAR-713.
- (7) Write **7** : Valid for MB addr 101~108 used to update FilterIP of SAR-713.
(Including Filter_StartIP and Filter_EndIP group)
- (8) Write **99** : Save all data to EEPROM including above 1,2,3,4,5,7 functions.
- (9) Write **100** : Reboot SAR-713 without saving any data.

※ **Addr 014 : Time Zone**

This address stores the GMT time zone value for NTP time calibration. For example, Taipei is GMT+8.

※ **Addr 015 : STA Duration**

STA means Short Time Average which is the acceleration (up to the setting of MB addr 18 => FW_v1.04) average in specified short time period in 10ms unit.

The other parameter is LTA which means Long Time Average. SAR-713 adopts STA/LTA algorithm for earthquake detection. When the value of STA (MB addr 15) divided LTA (MB addr 16) is greater than the level of STA/LTA (MB addr 17), it means earthquake happened. The default value is 200 which means 2 seconds and the max value is 6000 (60 sec). About the boot sequence of SAR-713, please refer to the section 4.5.1.

[Note]

1. STA value can't be greater than LTA.
2. If STA value is greater, the degree of change of STA/LTA is not sensitive.

※ Addr 016 : LTA Duration

LTA means Long Time Average which is the acceleration ([up to the setting of MB addr 18 => FW_v1.04](#)) average in specified long time period in 10ms unit. The other parameter is STA which means Short Time Average. SAR-713 adopts STA/LTA algorithm for earthquake detection. When the value of STA (MB addr 15) divided LTA (MB addr 16) is greater than the level of STA/LTA (MB addr 17), it means earthquake happened. The default value is 2000 which means 20 seconds and the max value is 6000 (60 sec). About the boot sequence of SAR-713, please refer to the section 4.5.1.

[Note]

1. LTA value needs to be greater than STA value.

※ Addr 017 : Earthquake Threshold in STA/LTA

[SAR-713 adopts STA/LTA algorithm for earthquake detection. When the value of STA \(MB addr 15\) divided LTA \(MB addr 16\) is greater than the value of this MB address, it means earthquake happened.](#) In this time, the value of earthquake event flag (MB addr 011) will be 1 and the DO output may be triggered. About DO trig condition, please refer to MB addr 023 and 024.

※ Addr 018 : Operation Mode Setting

bit 0 : [Intensity Degree Standard](#)

0 : CWB (Taiwan) Standard.

1 : [Other Area Standard. \(Modified by FW_v1.04\)](#)

[=> Please refer to the setting of MB Addr 109.](#)

bit 1 : GAS mode (DO Control Mode)

0 : The turn on time of these two DOs will be the same as earthquake event (MB addr 020).

1 : The turn on time of these two DOs will be only 2 seconds when earthquake happened. This is suitable for gas valve control.

bit 2 : Intensity Calculation Mode

0 : Intensity is determined by the acceleration of z-axis.

1 : Intensity is determined by the acceleration of other axis. (Modified by FW_v1.04). Please refer to the setting of MB Addr 110.

[Note]

1. For China, the intensity is determined by the maximum acceleration of the horizontal (X and Y axis) vector.

bit 3 : Connection to Host MB/TCP Server Function Automatically

0 : Disabled

1 : Enabled

When this function is enabled, the SAR-713 will try to connect to host MB/TCP server continuously until the connection is successful. About the IP address of host MB/TCP server, please refer to MB addr 076 ~ 079.

bit 4 : NTP Function Flag

0 : Disable NTP Function.

1 : Enable NTP Function.

About the IP address of NTP Server, please refer to MB addr 071~074 (first) and 059~062 (second) °

bit 5 : Filter_IP Function Flag

0 : Disabe Filter_IP Function.

1 : Enabe Filter_IP Function.

When Filter_IP function is enabled, then just the specific ip address range of host can connect to SAR-713. Please refer to the MB addr 101~108.

bit 6 : Automatic Zero Offset Function Flag

0 : Disabled

1 : Enabled

The update time period is determined by MB addr 022.

bit 7 : Pulse Filter Function Flag (Supported in FW_v1.03 or newer)

0 : Disabled

1 : Enabled

The MB Address 067 ~ 069 are the pulse filter setting value of 3-axis.

bit 8 : Load Zero Offset Record When SAR-713 Boot (Supported in FW_v1.07 or newer)

0 : Disabled

1 : Enabled

When applying to only measure acceleration or angle without detecting earthquake event, please follow the below steps.

(1) Disable "Automatic Zero Offset Function" (Set the b6 of MAddr_018 to 0)

(2) When the SAR-713 bootup, SAR-713 needs to load the zero offset record.

[1] Set b0 of MAddr_112 to 1 : Get the current zero offset value.

[2] Set b8 of MAddr_018 to 1 : Enable "Load Zero Offset Record" function.

(3) Write MAddr_013 to 99 : Save the above settings.

bit 9~15 : Reserved

When the data is changed, the MB addr 013 must be written 1 to save the data to EEPROM.

※ Addr 019 : DI / DO Status

The DI / DO status will be updated every second. The high byte represents DI and low byte as DO. There are four DIs map from bit0 ~ bit3 of high byte and two DOs map from bit0 ~ bit1 of low byte. Besides, the FC 0x02 Modbus command is supported and address equals 000, 001, 002, 003 represents DI0 ~ DI3. The FC 0x01 and address equals 000, 001 will be also used to read the status of DO0 and DO1.

※ Addr 020 : Earthquake Event Duration

When the earthquake is detected, SAR-713 will go into earthquake operation mode and the below tasks will be executed.

(1) Earthquake Event Flag will be 1.

(2) Max Acceleration, Intensity and time will be updated and stored in real time.

(3) The DOs will be determined to turn on or not.

(4) Count down the earthquake event duration timer and the timer will be reset if max acceleration occurred. When the time is up, SAR-713 will go into normal mode for earthquake detection again.

The address stores the timer value in 10ms unit. The default value is 3000 (30 seconds) and the max value is 6000 (60 seconds). [The end of earthquake event is according to the value.](#) About earthquake event sequence, please refer to section 4.5.2.

※ Addr 021 : Earthquake Event Remaining Time

The address stores the remaining time of earthquake event in 10ms unit. About the earthquake event sequence, please refer to the section 4.5.2.

※ Addr 022 : Zero Offset Sample Number

The address stores the sample number of zero offset and the sample time is 10 ms. The default value is 200 (2 seconds) and it means zero offset calculation will be executed every 2 seconds.

※ Addr 023 / 024 : DO0/ DO1 Trig Value

The address stores the trig value of DO0 and DO1 in [0.1 gal unit](#). The below table is the trig condition and the number with “ ” like “012” in the table represents the MB addr.

DO Status Trig Mode	DO0		DO1	
	ON	OFF	ON	OFF
STA/LTA	“012”=1 AND “028”>=“017” AND “008”>“023”	“020”	“012”=1 AND “028”>=“017” AND “008”>“024”	“020”

The default trig value of DO0 and DO1 are 200 and 800. (unit : [0.1 gal](#))

※ Addr 025 : Trig NTP Function

The address is used to trig NTP function. When writing 1, NTP function will be triggered immediately to synchronize with NTP Server 1. If writing 2, NTP function will be triggered immediately to synchronize with NTP Server 2. After the process of NTP function completed, the value will reset to be zero.

※ Addr 026 : NTP Update Time Period

The address stores the update time period of NTP function in minute unit. The default value is 5 (5 minutes) and it means NTP function will be executed every 5 minutes.

※ Addr 027 : The Activated NTP Server No.

The address stores the activated NTP server no. If the value is 1, it means time calibration of SAR-713 will synchronize with NTP server 1. The default value is 1.

※ Addr 028 : Real-Time STA / LTA

The address stores the real-time STA/LTA value. When this value is greater than the value in MB addr 017, it means earthquake event happened.

※ Addr 029 : Max Acceleration of X-Axis in Earthquake Event

The address stores the max acceleration of X-Axis in this earthquake event in count unit. The value will be updated until next earthquake event detected.

※ Addr 030 : Max Acceleration of Y-Axis in Earthquake Event

The address stores the max acceleration of Y-Axis in this earthquake event in count unit. The value will be updated until next earthquake event detected.

※ Addr 031 : Max Acceleration of Z-Axis in Earthquake Event

The address stores the max acceleration of Z-Axis in this earthquake event in count unit. The value will be updated until next earthquake event detected.

※ Addr 032 : X-Axis Acceleration of Max Vector in Earthquake

The address stores the X-Axis acceleration of Max Vector in this earthquake event in count unit. The value will be updated until next earthquake event detected.

※ Addr 033 : Y-Axis Acceleration of Max Vector in Earthquake

The address stores the Y-Axis acceleration of Max Vector in this earthquake event in count unit. The value will be updated until next earthquake event detected.

※ Addr 034 : Z-Axis Acceleration of Max Vector in Earthquake

The address stores the Z-Axis acceleration of Max Vector in this earthquake event in count unit. The value will be updated until next earthquake event detected.

※ Addr 035 ~038 : Data File Function of Earthquake Event

[MB addr 035]

The address is used to determine if data file will be recorded in flash memory of SAR-713 when earthquake event detected.

0 : Disabled (default)

1 : Enabled

[MB addr 036]

There are two data blocks whose size is 32 MB individually in SAR-713 and they are Disk A and Disk B. The address is used to determine which data block to record earthquake data file.

0 : Disk A (32MB) (default)

1 : Disk B (32MB)

[MB addr 037]

The address is used to show the remaining size of the specific data block in KB unit. If MB addr 036 equals 0, it means the remaining size of Disk A. If MB addr 036 equals 1, it means the remaining size of Disk B. When the value is

smaller than 512 (KB), it means the space of data block is full.

[Note]

1. The max size of earthquake data file in SAR-713 is about 48 KB and it consists of Pre-Time (10 seconds), EQ-Time (60 seconds) and Post-Time (10 seconds).

[MB addr 038]

The address is used to determine the process when the space of the specific data block is full.

0 : Delete the oldest earthquake data file to save the newest earthquake data file. (default)

1 : Don't save the newest earthquake data file.

※ Addr 039 : Streaming Data Control

The function is supported in [FW_v1.02 or newer](#). When the address is written to 1, SAR-713 will save 3-axis acceleration data to internal buffer every 10ms. When the data count reaches 200 (every **2 seconds**), then SAR-713 will send the streaming data packet via Ethernet. Write 0 to this address will stop the streaming. The format of the streaming data packet is described as below.

WORD	Description	Note
1	0x33, 0x37	Sync-Data
2	0x35, 0x37	Sync-Data
3	0x37, 0x35	Sync-Data
4	0x37, 0x33	Sync-Data
5	Year	Event time will be replaced when earthquake is detected.
6	Month	
7	Day	
8	Hour	
9	Minute	
10	Second(High Byte), 10ms(Low Byte)	
11	Event Flag	
12	Maximum Intensity	
13	Current Intensity	
14	X axis Acceleration of Record 1	
15	Y axis Acceleration of Record 1	
16	Z axis Acceleration of Record 1	
..	..	
611	X axis Acceleration of Record 200	
612	Y axis Acceleration of Record 200	
613	Z axis Acceleration of Record 200	

[Note]

1. The “WORD” data of the stream data packet consists of two bytes. The low byte will be sent first and then will be the high byte.
2. TCP port 1501 is used for “Streaming Data” function and the maximum client number of port 1501 is three.

※ Addr 040 : Max STA/LTA in Earthquake Event

The address stores the max STA/LTA value in last earthquake event and it will be updated until next earthquake event detected.

※ Addr 041 ~ 046 : Earthquake Event Time

These addresses store the earthquake event time including “Year”, “Month”, “Day”, “Hour”, “Minute” and “Second”. They will be updated until next earthquake event detected.

※ Addr 047 ~ 052 : System Date / Time Information

These addresses store the real-time system date and time information including “Year”, “Month”, “Day”, “Hour”, “Minute” and “Second”.

※ Addr 053 ~ 058 : System Date / Time Setting

These addresses are used to set system date and time (RTC) including “Year”, “Month”, “Day”, “Hour”, “Minute” and “Second”. When writing 3 in MB addr 013, the system RTC will be updated by these addresses.

※ Addr 059 ~ 062 : IP Address of NTP Server 2 Setting

These addresses store the IP address of NTP server 2 and the default IP address is 192.43.244.18 (time.nist.gov). If these addresses are changed, remember to write 4 in MB addr 013 to save data in EEPROM.

When time calibration of SAR-713 with NTP server 2 failed three times continuously, SAR-713 will change to synchronize with NTP server 1.

※ Addr 063 / 064 : Pre-Time / Post-Time Setting

These addresses store the pre-time and post-time for earthquake event data file in 10ms unit and the default value is zero. The total time of earthquake data file consists of pre-time(063), event-time(020) and post-time(064). The max value of pre-time and post-time is 1000 (10 seconds).

※ Addr 065 / 066 : Counts and Total Counts of Earthquake Event [MB addr 065]

The address stores the earthquake event counts from boot up. But the value will be reset to be zero when SAR-713 reboots.

[MB addr 066]

The address stores the earthquake event total counts and saved in EEPROM. So it will not be cleared when SAR-713 reboots. If factory default recovery function is executed or set to be zero by manual and it will be zero.

※ Addr 067 ~ 069 : Pulse Filter Value of 3-Axis Acceleration

The function is supported in FW_v1.03 or newer. These addresses store the pulse filter value in count unit for 3-axis acceleration. They are used to filter the abnormal acceleration of 3-axis. The MB addr 067 is for X-axis, the MB addr 068 is for Y-axis and the MB addr 069 is for Z-axis. The default value is 16384 count (1g).

For example, if the setting is 10000, it means that if the acceleration difference value between this time and the previous time is bigger than 10000, then it will keep the previous acceleration value this time.

※ Addr 070 : Pulse Filter Total Count of 3-Axis

The function is supported in FW_v1.03 or newer. The address store the total count for pulse filter function of 3-axis executed. It can be used to detect the pulse filter value in MB addr 067~069 if they are appropriate or not.

※ Addr 071 ~ 074 : IP Address of NTP Server 1 Setting

These addresses store the IP address of NTP server 1 and the default IP address is 59.124.196.84 (time.stdtime.gov.tw). If these addresses are changed, remember to write 4 in MB addr 013 to save data in EEPROM.

When time calibration of SAR-713 with NTP server 1 failed three times continuously and SAR-713 will change to synchronise with NTP server 2.

※ Addr 075 : System Time Information - Week

The address stores the week information of system time and its value from 1 to 7 represents Monday to Sunday.

※ Addr 076 ~ 079 : Host MB/TCP Server IP Address Setting

These addresses store the host MB/TCP server IP address and the default IP address is 192.168.255.2. If these addresses are modified, remember to write 5 in MB addr 013 to save data in EEPROM. If the bit 3 of MB addr 018 set to be 1, SAR-713 will connect to host MB/TCP server with the assigned IP address automatically until the connection is successful.

※ **Addr 080 ~ 091 : SAR-713 Network Address Setting**

These addresses 180~183 are used to store IP address, 184~187 store Subnet Mask and 188~191 store Gateway of SAR-713. The factory default value of IP address is 192.168.255.1, Mask is 255.255.0.0 and Gateway is 192.168.255.254. If these addresses are modified, remember to write 2 in MB addr 013 to save data in EEPROM.

※ **Addr 092 : Available MB/TCP Connections for Host**

SAR-713 supports up to 10 MB/TCP client connection and the address stores the available connection number.

※ **Addr 093 : MB/TCP Client Update Period**

The address stores the update period of MB/TCP client of SAR-713 in 10 ms unit. The default value is 10 (100ms) and the min value is 1 (10ms).

[Note]

1. After SAR-713 connects to host MB/TCP server successfully, SAR-713 will send data automatically and the time period is precise.

※ **Addr 094 : Modbus TCP/RTU Server Station No. Setting**

The default value is 1 and its range is from 1 to 255. When it is modified, remember to write 1 in MB addr 013 to save data in EEPROM.

※ **Addr 095 : Debug Message Enable Flag**

The default value is zero and it means no debug message will be sent from COM1 (debug Port) of SAR-713. If users set it to be 1, then the debug message will be sent and the communication parameter of COM1 is "115200,N,8,1". After SAR-713 reboots, it will be set to 0 again.

※ **Addr 096 : Remaining Time before Earthquake Detection**

The address stores the remaining time before earthquake detection function of SAR-713 starts and its unit is 10ms. When the value is zero, it means SAR-713 is ready for earthquake detection. About the boot sequence of

SAR-713, please refer to section 4.5.1.

※ **Addr 097 : DHCP Client Function Status**

The address stores the result of DHCP client function.

0 : DHCP Client disabled

1 : DHCP Client enabled and run successfully.

2 : DHCP Client enabled but run failed. (Check network and DHCP Server)

※ **Addr 098 : Axis-Mapping Setting**

The address stores the installation mode of SAR-713.

0 : For horizontal installation of SAR-713 (default)

0 : For vertical installation of SAR-713

※ **Addr 099 : SAR-713 Firmware Version**

The address stores firmware version of SAR-713. For example, 0x0102 means v1.02.

※ **Addr 100 : SAR-713 Machine Serial Number**

The address stores machine serial number of SAR-713. Its range is from 0~65535 and the default value is 0.

※ **Addr 101 ~ 108 : FilterIP Range Setting**

These addresses are used to set the FilterIP range including Filter_StartIP (101~104) and Filter_EndIP(105~108). Three modes are supported and described as below.

1. [**Lock Single IP**]

If just one host IP (192.168.0.100) can connect to SAR-713, then set Filter_StartIP and Filter_EndIP to be 192.168.0.100.

2. [**Lock Group IP**]

If host IP from 192.168.0.100 to 192.168.0.200 all can connect to SAR-713, then set Filter_StartIP to be 192.168.0.100 and Filter_EndIP to be 192.168.0.200.

3. [**Lock Group IP by using "IP+MASK"**]

- (A) If IP from 192.168.0.0 to 192.168.0.255 all can connect to SAR-713, then set Filter_StartIP to be 192.168.0.1 and Filter_EndIP to be 255.255.255.0 (Filter_EndIP means MASK).
- (B) If IP from 192.168.0.xxx to 192.168.1.xxx all can connect to SAR-713, then set Filter_StartIP to be 192.168.0.1 and Filter_EndIP to be 255.255.254.0 (Filter_EndIP means MASK).
- (C) If Filter_EndIP is 255.255.255.255, then just host IP which is equal to Filter_StartIP can connect to SAR-713.

If data from MB addr 101 to 108 are modified, remember to write 7 to MB addr 013 to save data in EEPROM. At last, remember to set bit 5 in MB addr 018 to be 1 to enable Filter_IP function.

※ Addr 109 : Extended Intensity Standard Option

The address stores the extended intensity standard option for other area. When the bit 0 of MB Addr 018 is 1, then the below intensity standard option are supported.

0 : GB/T 17742-2008 => China Intensity Standard.

1 : Modified Mercalli Intensity (MMI) => Europe and America Intensity Standard.

2 : JMA (Japan Meteorological Agency) => Japan Intensity Standard.

[Note]

1. The below table is the intensity in SAR-713 corresponding to the intensity in JMA scale standard.

Intensity in SAR-713	Corresponding Intensity in JMA
1	1
2	2
3	3
4	4
5	5-lower
6	5-upper
7	6-lower
8	6-upper
9	7

※ Addr 110 : Extended Intensity Calculation Mode Option

The address stores the extended intensity calculation mode option. When the bit 2 of MB Addr 018 is 1, then the below intensity calculation mode option are supported.

- 0 : Intensity is determined by the max acceleration of tri-axial vector.
- 1 : Intensity is determined by the max acceleration of horizontal (X+Y) vector.

※ Addr 111 : Intensity Degree Value

When SAR-713 detected the earthquake happened, the address stores the acceleration trigger value of the max intensity in the current intensity standard. The unit of the address is 0.1 gal and the intensity degree value is adopted by the firmware of SAR-713. It is useful when users want to set the acceleration trigger value of DO switch according to the intensity degree.

※ Addr 112 : Extra Function Trigger

It is used to trig the extra function.

bit 0 : Trig "Zero Offset" function once. (Supported in FW_v1.07 or newer)

1 : Trig immediately and then the bit 0 will be set back to 0.

The rest MB addresses are reserved, please don't use them.

4.4. Modbus Function

SAR-713 supports Modbus function 1,2,3,6 and 16. The FC03 is used to read MB register data. FC06 and FC16 are used to write MB register data.

SAR-713 supports MB/TCP and MB/RTU communication simultaneously. When using MB/RTU, the MB address of SAR-713 is 1 for default and the communication parameter of com port is "115200, 8, N, 1".

For Example : (Set STA value to be 2.5 sec by using MB/TCP)

The unit in STA (MB addr 015) is 10ms, so 2.5 sec equals 250*10ms and the hex value of 250 is 0x00FA. So the MB/TCP command of FC06 will be as below.

TID (hex)	PID (hex)	Field Length (hex)	Net ID (hex)	FC (hex)	Reference number. (hex)	Register value (hex)
01 02	00 00	00 06	01	06	00 0F	00 FA

TID: Transaction Identifier

PID: Protocol Identifier

Net ID: Station number

FC: Function Code

4.5 SAR-713 Sequence

4.5.1. Boot Sequence

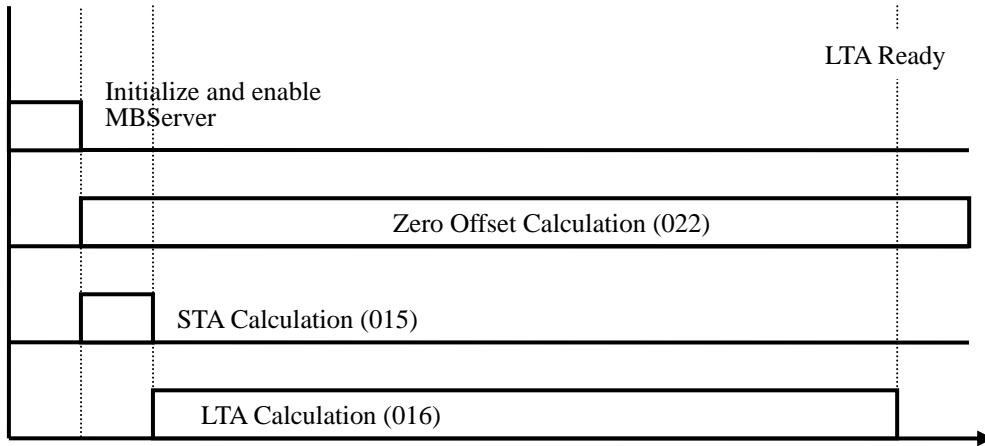

4.5.2. Earthquake Event Sequence

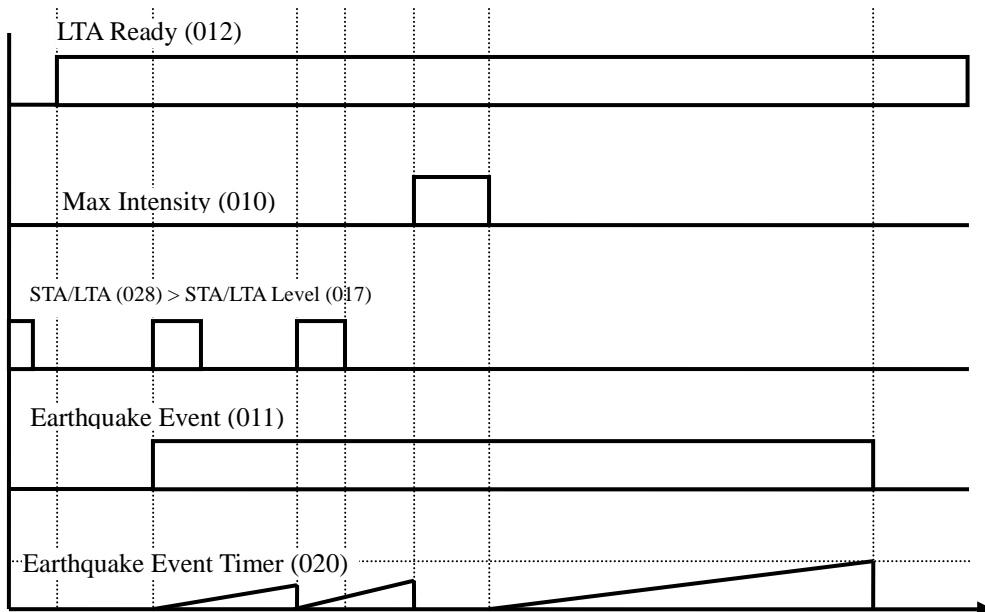

5. Software Utility :

SAR713 utility is provided by ICP DAS to connect to SAR-713 to set data and get information easily and quickly and can also display the real-time tri-axial acceleration trend for analysis conveniently. SAR713 utility can be downloaded from the ICP DAS web site :

<http://ftp.icpdas.com.tw/pub/cd/sar-713/software/utility/>. The following is the description of SAR-713 utility functions.

5.1 Connection Function

Three ways are provided to communicate between SAR-713 and host PC. They are Modbus/TCP Client, Modbus/RTU Client and Modbus/TCP Server like Fig 5.1-1.

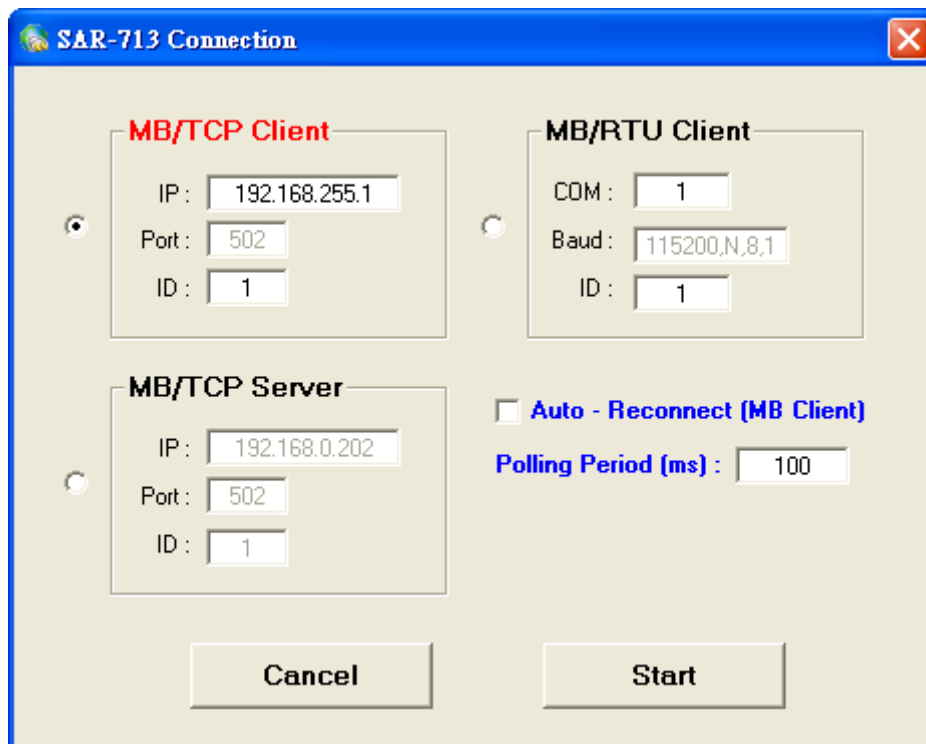

Fig 5.1-1 Connection Screen

(1) Modbus/TCP Client Connection :

Click "MB/TCP Client" option and type in IP Address and Modbus ID in "IP" and "ID" field. If "Auto – Reconnect" function is checked, when the communication is disconnected, utility will try to connect to SAR-713

automatically about every 3~5 seconds. The "Polling Period" field is used to set the polling data period and 100 means utility will get SAR-713 data every 100ms and the minimum value is 10ms for MB/TCP client communication. When the above configuration finished, click "Start" button to connect to SAR-713.

(2) Modbus/RTU Client Connection:

Click "MB/RTU Client" option and type in Com Port number in "COM" field and Modbus ID in "ID" field. If "Auto – Reconnect" function is checked, when the communication is disconnected, utility will try to connect to SAR-713 automatically about every 3~5 seconds. The "Polling Period" field is used to set the polling data period and 100 means utility will get SAR-713 data every 100ms and the minimum value is 20ms for MB/RTU client communication. When the above configuration finished, click "Start" button to connect to SAR-713.

(3) Modbus/TCP Server Connection:

Click "MB/TCP Server" option and the "Auto – Reconnect" and "Polling Period" options in this mode are disabled. Click "Start" button to start MB/TCP server function and wait for SAR-713 to connect to host PC. (This function is useful when host PC doesn't know the IP address of SAR-713.)

Users can click "Connect" item in the menu bar and choose "Connect To SAR-713" function to open "Connectoin Screen" like Fig 5.1-2 or "Disconnect" function to disconnect to SAR-713 like Fig 5.1-3.

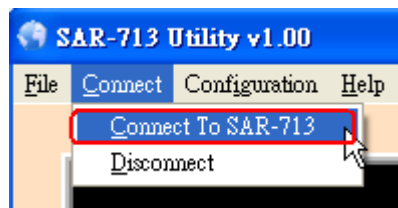

Fig 5.1-2 Open SAR-713 Connection Screen

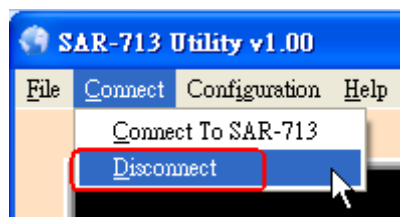

Fig 5.1-3 Disconnect Function

After connecting to SAR-713 is successful, the main screen will be opened

and display the real-time tri-axial acceleration trend and earthquake event information like Fig 5.1-4.

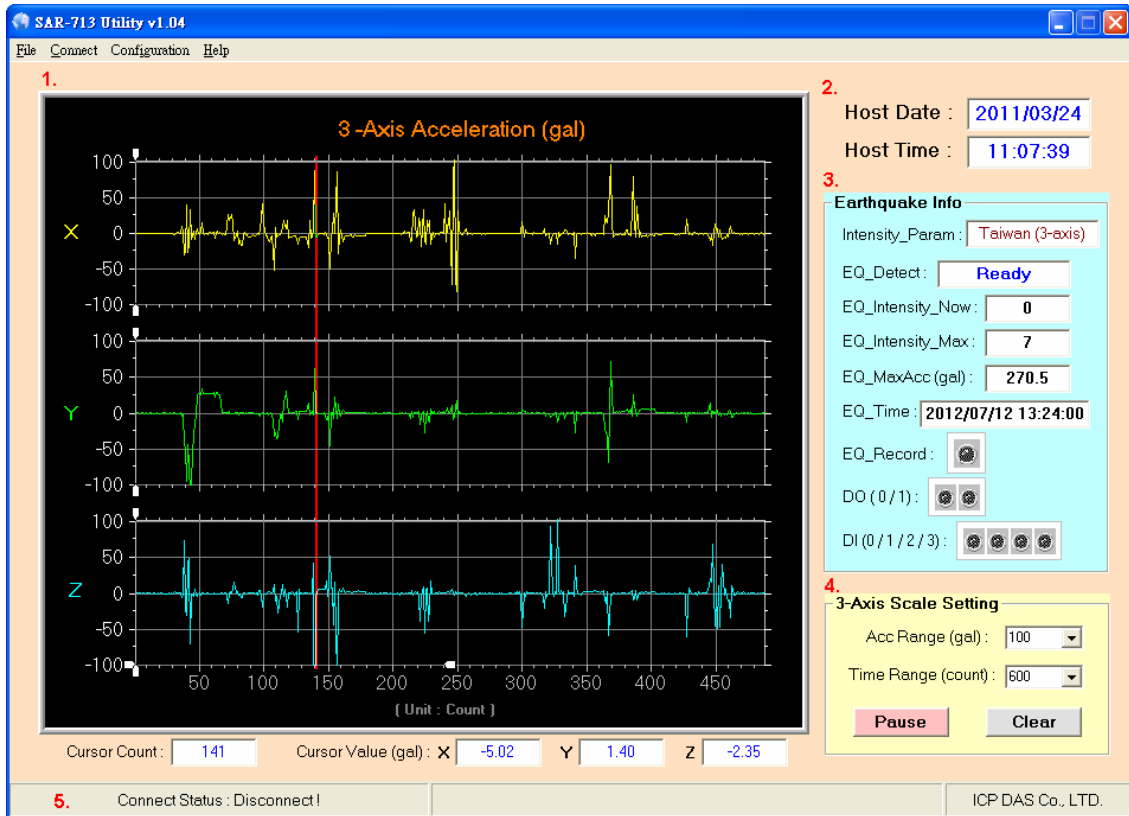

Fig 5.1-4 Main Screen

In main screen, five functions are provided and the following is the description.

1. Real-Time tri-axial Acceleration Trend :

X-axis trend is yellow, Y-axis trend is green and Z-axis trend is blue. The information of the vertical red line will be shown in the fields below trend including corresponding tri-axial acceleration value.

2. Host Date/Time Info :

Show the host PC system date and time information.

3. Earthquake Event Info :

Including the following nine information :

- (1) Intensity Param : SAR-713 current earthquake detection method including intensity standard and acceleration calculation mode.
- (2) EQ_Detect : SAR-713 current earthquake detection status
 - [1] Preparing... : STA and LTA data collection mode.
 - [2] Ready : Earthquake event detection mode.
 - [3] Happened : Earthquake event happened mode.
- (3) EQ_Intensity_Now : Real-time intensity in earthquake event.

- (4) EQ_Intensity_Max : The max intensity in earthquake event.
- (5) EQ_MaxAcc (gal) : The max acceleration in earthquake event.
- (6) EQ_Time : The earthquake event date and time.
- (7) EQ_Record : The earthquake event data recored function flag.
(Yellow means enabled. Black means disabled.)
- (8) DO (0/1) : The earthquake event DO channel ON/OFF status.
(Red means ON. Black means OFF)
- (9) DI (0/1/2/3) : The earthquake event DI channel triggered status.
(Green means ON. Black means OFF)

4. Trend Scale Setting :

- (1) Acc Range (gal) : Tri-axial acceleration range setting.
- (2) Time Range (count) : Time range setting.
- (3) “Pause/Run” button : Pause / Run trend function.
- (4) “Clear” button : Clear trend data.

5. Status Bar Info :

Show the connection status between host PC and SAR-713. If connection is successful, then it will show the IP address of SAR-713 and update time like Fig 5.1-5.



Fig 5.1-5 Status Bar Info

If users want to save the setting parameters of connection and main screen, please click “File” item in the menu bar and choose “Save INI Setting” function like Fig 5.1-6 and SAR713_Utility.ini file will be produced. When connecting to SAR-713 next time, it will load the setting of SAR713_Utility.ini file to initialize the parameters of SAR-713 utility.

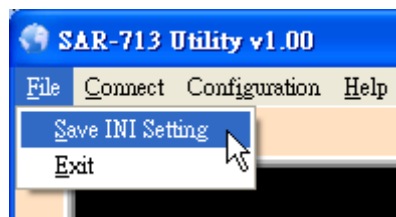

Fig 5.1-6 Save SAR713_Utility Initial Settings

5.2 Module Configuration Function

Click “Configuration” item in the menu bar and choose “Module Config” function like Fig 5.2-1. Then the module configuration screen will be opened like

Fig 5.2-2.

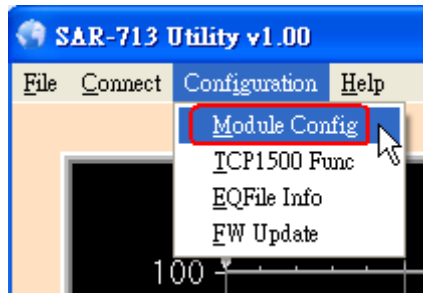

Fig 5.2-1 Open Module Configuratoin Screen



Fig 5.2-2 Module Configuratoin Screen

The following is the function description of module configuratoin screen.

(1) MB Address Table Frame :

Show the real-time data of all Modbus address parameters. Blue fields are read-only, red fields are able to be set and grey fields are reserved.

(2) Display Type Frame :

Show data in hex or decimal format.

(3) MB Data Setting Frame :

[1] Set_Data button :

Type in modbus parameter address in “Addr” field and value in “Data” field, and then click “Set_Data” button to modify the setting. The result will

show in “Res” field.

[2] MBBAddr_Info button :

Type in modbus parameter address in “Addr” field and then click “MBAddr_Info” button to show the detailed information like Fig 5.2-3.

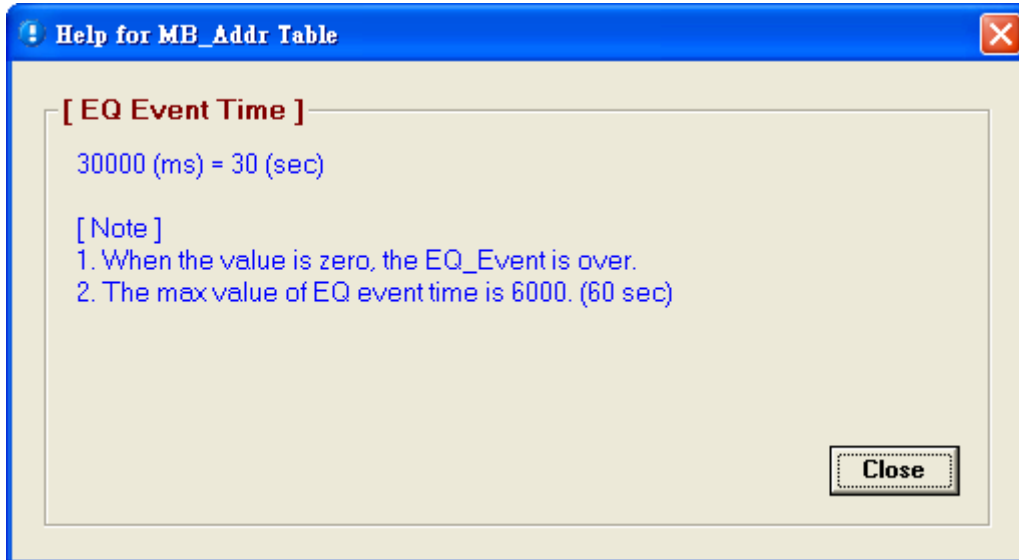

Fig 5.2-3 Modbus Parameter Address Function Information

5.3 TCP1500 Function

Click “Configuration” item in the menu bar and choose “TCP1500 Func” function like Fig 5.3-1. Then the TCP1500 screen will be opened. Four functions are provided and they are “EQ_File”、“TCP_Info”、“Mod_Info”、“Others” like Fig 5.3-2.

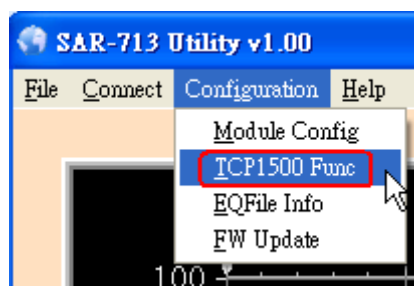

Fig 5.3-1 Open TCP1500 Screen

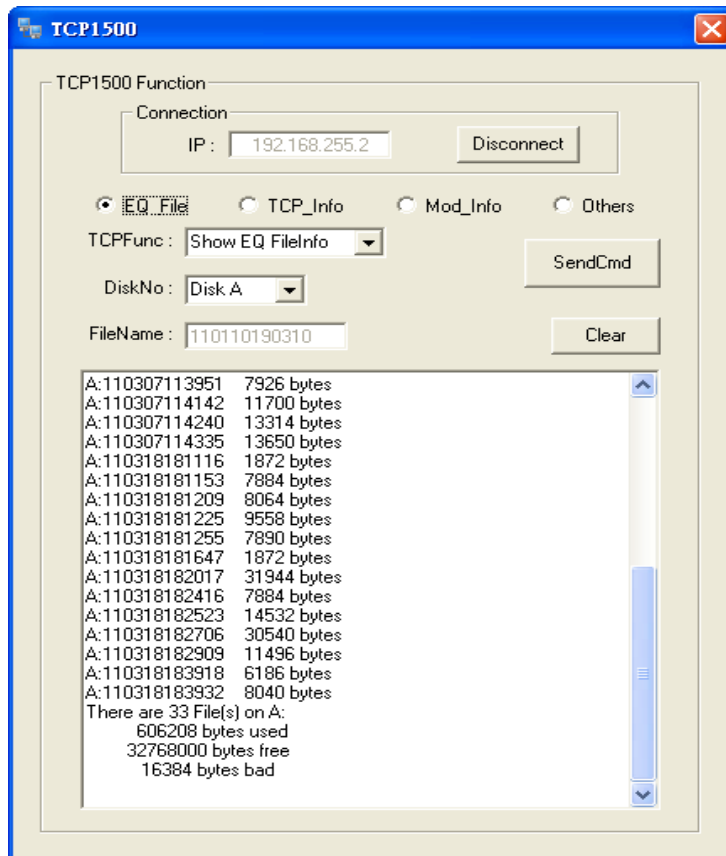

Fig 5.3-2 TCP1500 Screen

Users need to connect to TCP1500 server of SAR-713 first before using TCP1500 functions. Type in the IP address of SAR-713 in “IP” field and click “Connect” button to connect to SAR-713. The connection result will show in the below field. If the connection is successful, then the message - “***** Connect to SAR-713 Success *****” will be shown like Fig 5.3-3.

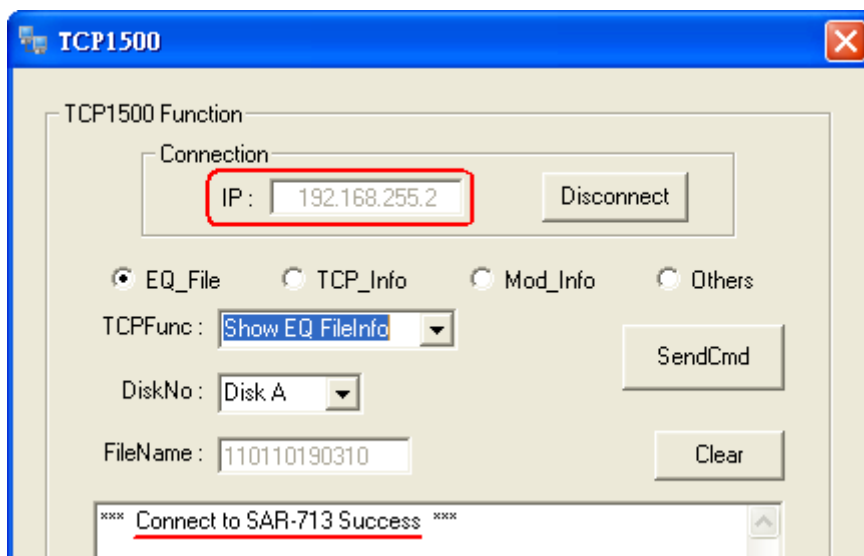

Fig 5.3-3 Connect to TCP1500 Server of SAR-713

The following is the four functions description.

(1) “EQ_File” – Earthquake Record File :

[1] Show EQ FileInfo :

TCPFunc field : Chose ”Show EQ FileInfo” item

DiskNo field : Choose ”Disk A” or ”Disk B” item

Click ”SendCmd” button and it will response the all file information in assigned DiskNo like Fig 5.3-2.

[2] Return EQ File :

TCPFunc field : Choose ”Return EQ File” item

DiskNo field : Choose ”Disk A” or ”Disk B” item

FileName field : Type in the earthquake file name

Click ”SendCmd” button and it will return the assigned earthquake file like Fig 5.3-4 and the file will be saved in the same folder as SAR-713 utility.

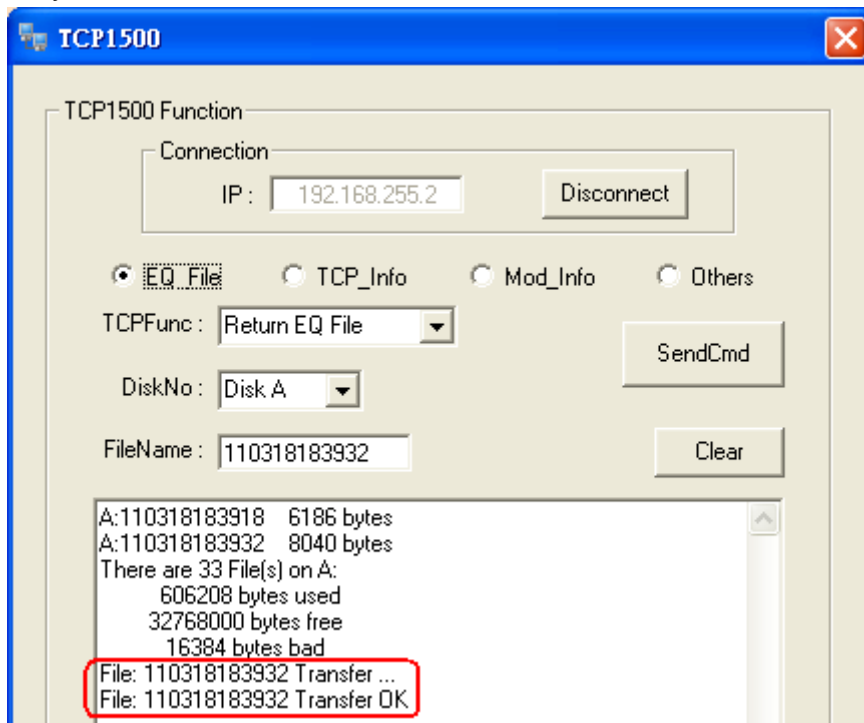

Fig 5.3-4 Return the Assigned Earthquake File

[3] Return All EQ Files :

TCPFunc field : Choose ”Return All EQ Files” item

DiskNo field : Choose ”Disk A” or ”Disk B” item

Click ”SendCmd” button and it will return all earthquake files in the assigned DiskNo like Fig 5.3-5 and these files will be saved in the same folder as SAR-713 utility.

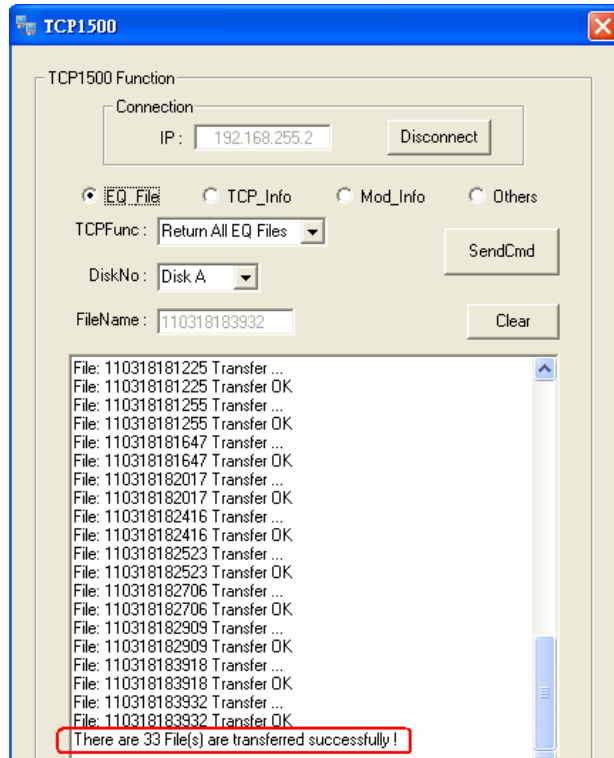

Fig 5.3-5 Return all Earthquake Files in the Assigned DiskNo

[4] Delete EQ File :

TCPFunc field : Choose "Delete EQ File" item

DiskNo field : Choose "Disk A" or "Disk B" item

FileName field : Type in the earthquake file name

Click "SendCmd" button and it will delete the assigned earthquake file in assigned DiskNo like Fig 5.3-6.

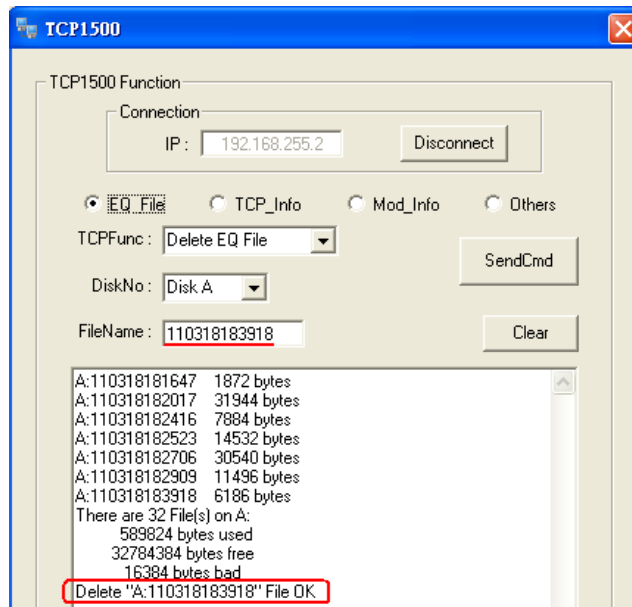

Fig 5.3-6 Delete the Assigned Earthquake File

[5] Delete All EQ Files :

TCPFunc field : Choose "Delete All EQ Files" item

DiskNo field : Choose "Disk A" or "Disk B" item

Click "SendCmd" button and it will show the "Sure to Delete All EQ File on Disk B ?" warning message first. If clicking "OK" button, all earthquake files in assigned DiskNo will be deleted like Fig 5.3-7.

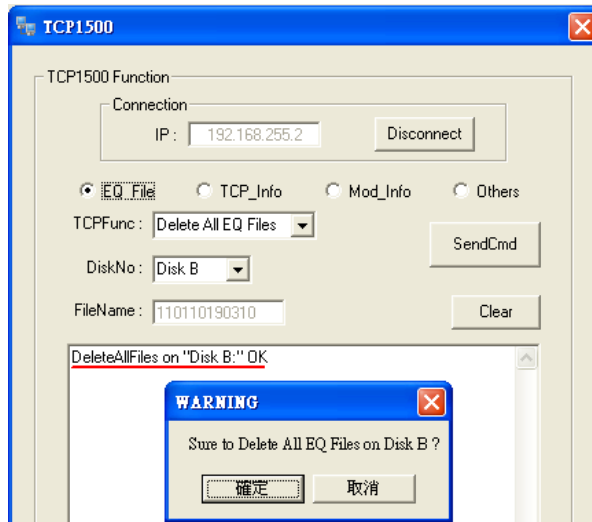

Fig 5.3-7 Delete all Earthquake Files in Assigned DiskNo

[4] Reset EQ Flash :

TCPFunc field : Choose "Reset EQ Flash" item

Click "SendCmd" button and it will show the "Sure to Reset EQ Flash ?" warning message first. If clicking "OK" button, all earthquake files in Flash including Disk A and Disk B will be deleted like Fig 5.3-8.

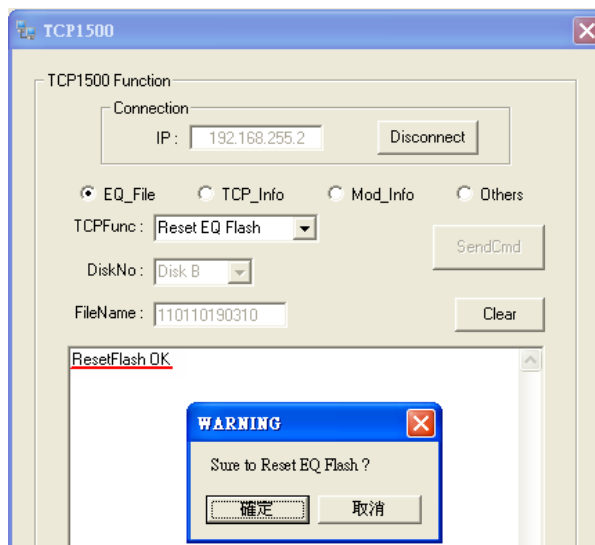

Fig 5.3-8 Reset Earthquake File Flash

(2) “TCP_Info” – TCP Information :

[1] Show All MB/TCP Connected IP :

TCPFunc field : Choose ”Show All MB/TCP Connected IP” item
Click ”SendCmd” button and it will response all IP address of MB/TCP client which connect to SAR-713 like Fig 5.3-9.

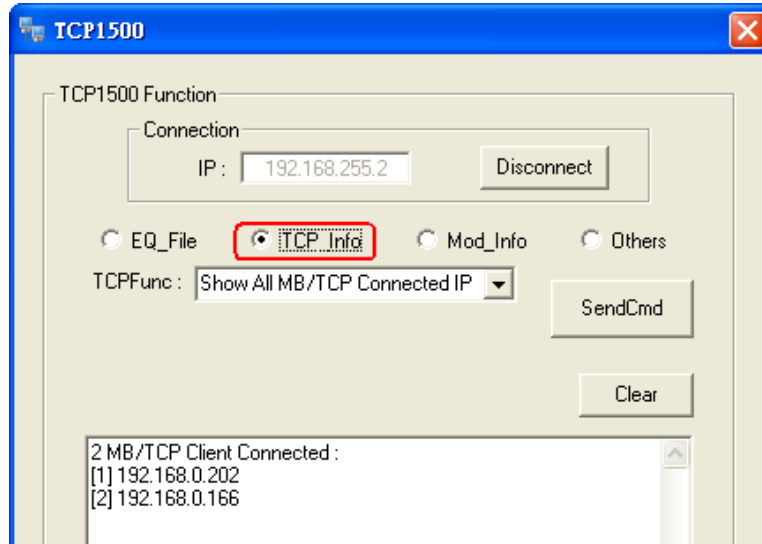

Fig 5.3-9 Show All Connected MB/TCP Client IP

(3) “Mod_Info” – Module Hardware Information:

[1] Show Hardware Serial Number :

TCPFunc field : Choose ”Show Hardware Serial Number” item
Click ”SendCmd” button and it will response the Hardware Serial Number of SAR-713 like Fig 5.3-10. The hardware Serial Number can be used to protect users’ own program for the assigned SAR-713 module.

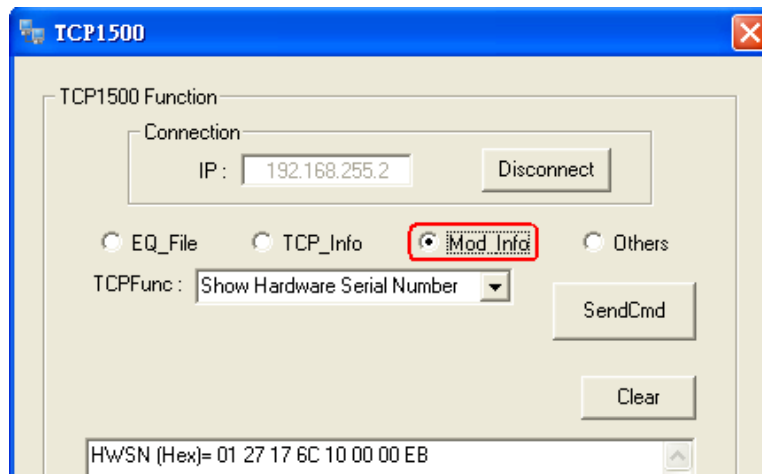

Fig 5.3-10 Show Hardware Serial Number of SAR-713

(4) “Others” – Other Function :

This function is reserved now.

5.4 EQFile_Info Function

It is used to load the earthquake file (*.bin) of SAR-713 and show all the information for analysis. The following is the detailed description.

- (1) Click “Configuration” item in the menu bar and choose “EQFile Info” function like Fig 5.4-1. The EQFile Info screen will be opened like Fig 5.4-2.

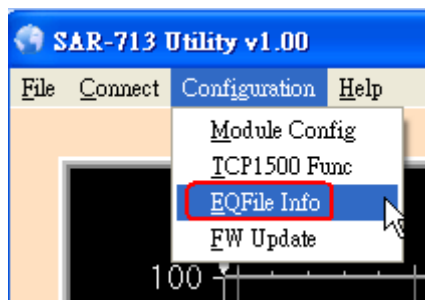

Fig 5.4-1 Open EQFile Info Screen

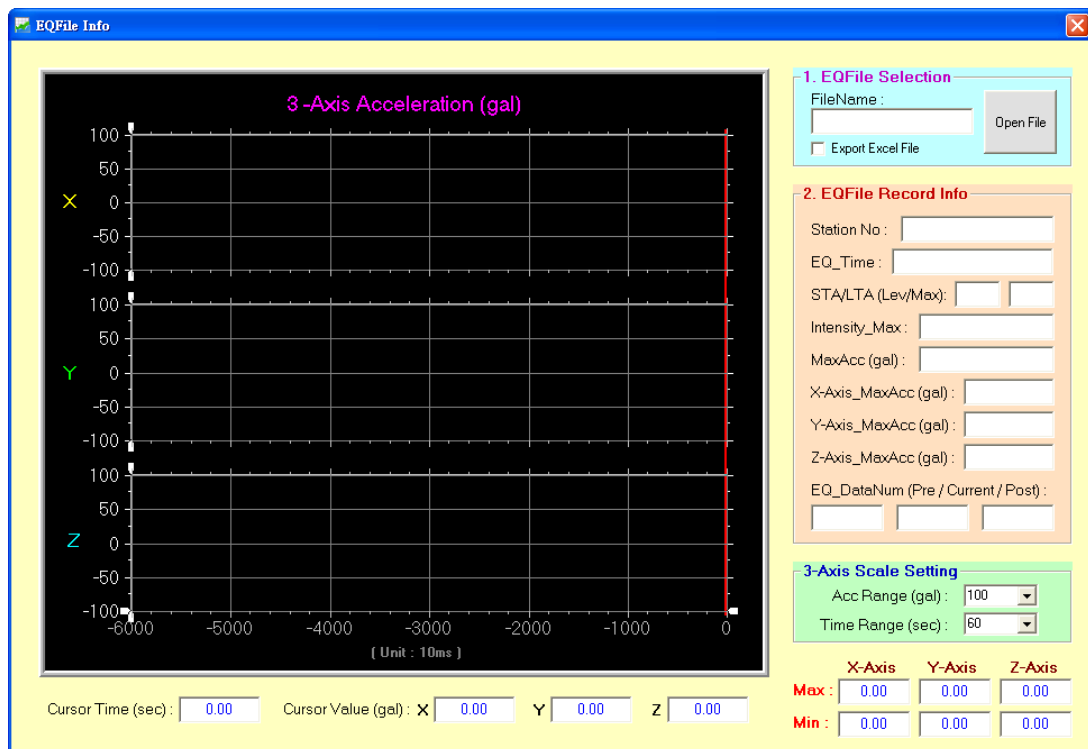

Fig 5.4-2 EQFile Info Screen

- (2) Click “Open File” button in the “EQFile Selection” frame and choose the earthquake file (*.bin) like Fig 5.4-3. The information recorded in earthquake file will be shown with trend and data format like Fig 5.4-4.

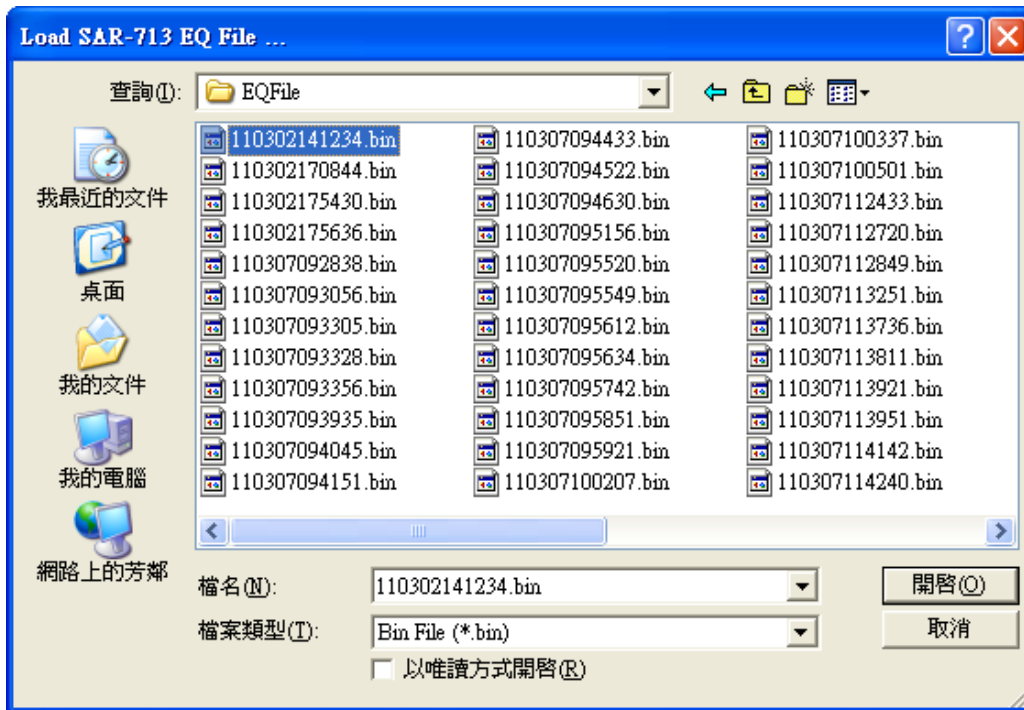

Fig 5.4-3 Assign the Earthquake File

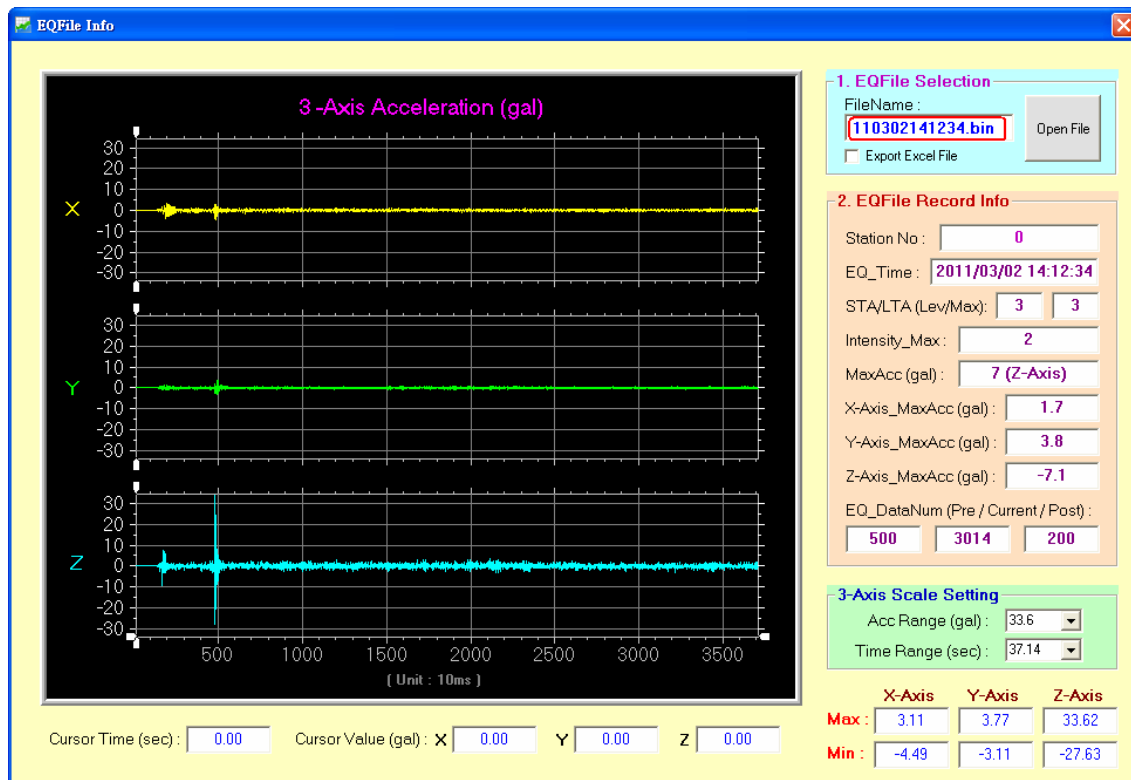

Fig 5.4-4 Show the Information of Earthquake File

The earthquake file of SAR-713 includes the following information.

- [1] SAR-713 Station No.
- [2] Earthquake Event Date and Time
- [3] STA/LTA Information
- [4] Max Intensity
- [5] Max Acceleration
- [6] Tri-axial Max Acceleration
- [7] Tri-axial Pre- / Current / Post- Acceleration

(3) “Export Excel File” Function (Supported by Utility v1.02 or newer)

If “Export Excel File” option is checked like Fig 5.4-5, then SAR-713 utility will produce a excel file (like 110302141234.xls) for the assigned EQFile (like 110302141234.bin).

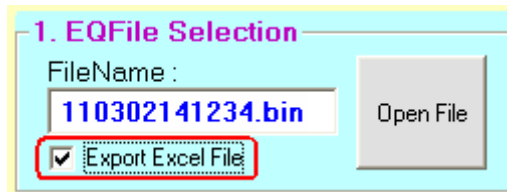

Fig 5.4-5 “Export Excel File” Function

5.5 Firmware Update

Click “Configuration” item in the menu bar and choose “FW Update” function like Fig 5.5-1. The Firmware Update screen will be opened like Fig 5.5-2.

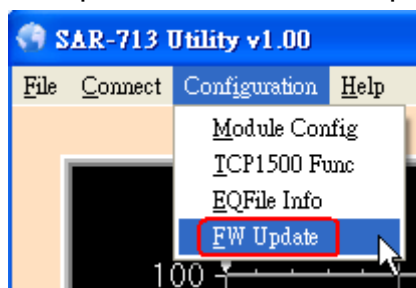

Fig 5.5-1 Open Firmware Update Screen

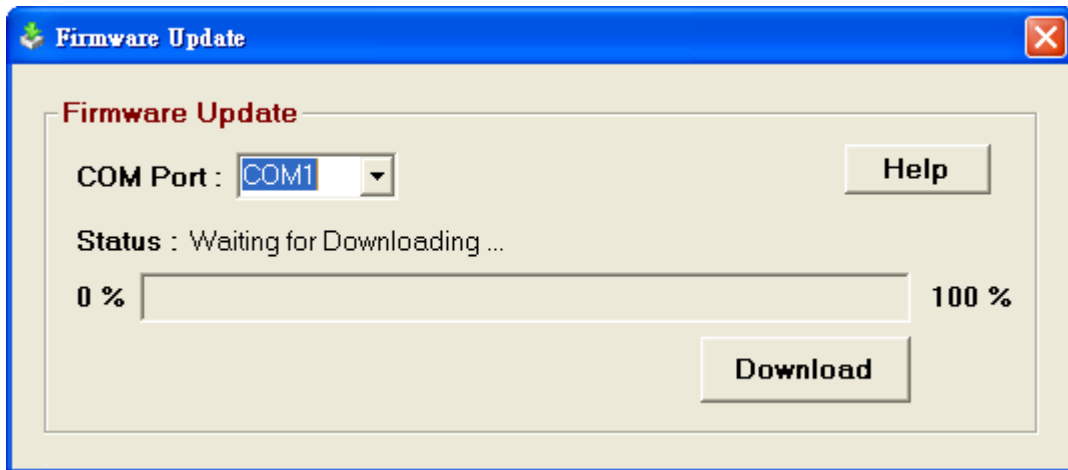

Fig 5.5-2 Firmware Update Screen

The following is the firmware update description.

(1) Help Button :

Show the firmware update steps of SAR-713 like Fig 5.5-3.

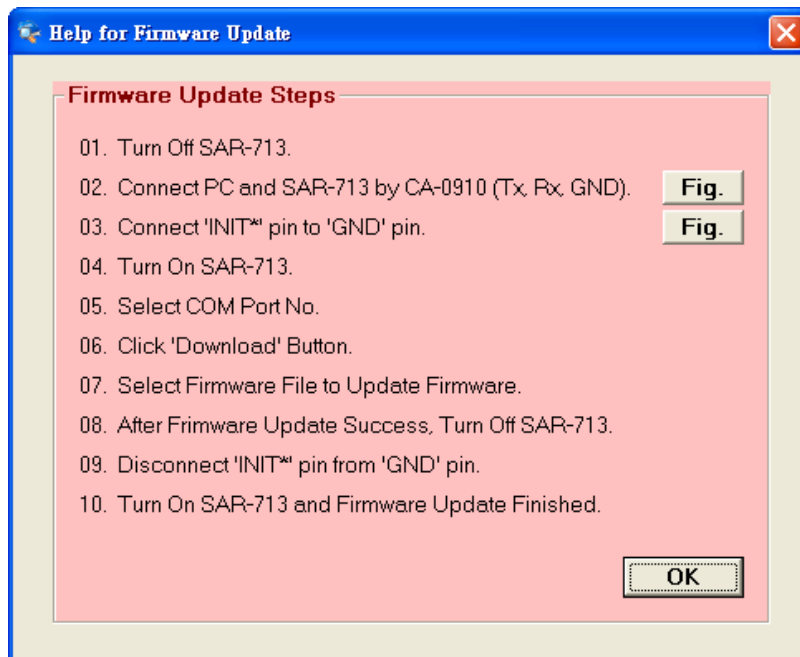

Fig 5.5-3 Help for Firmware Update

(2) Download Button :

After finishing the steps 1~4 for hardware setting, then continues the step 5~7. First choose the com port number and then click “Download” button to choose firmware file (Firmware filename is like SR713_XX.exe and XX means version. So 10 means v1.0) like Fig 5.5-4. Then it will start the firmware update process like Fig 5.5-5. After firmware update process finished, it will show the result like Fig 5.5-6.

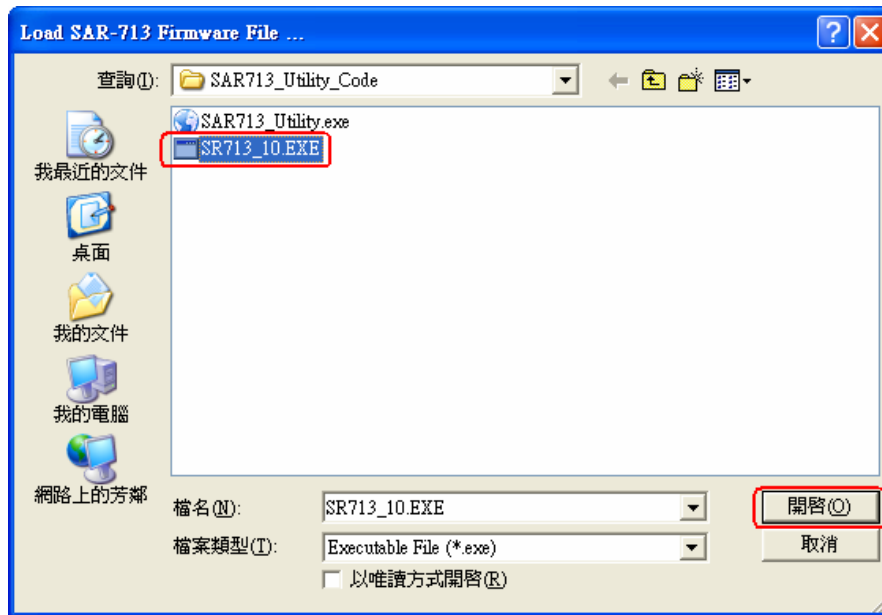

Fig 5.5-4 Choose the Firmware File

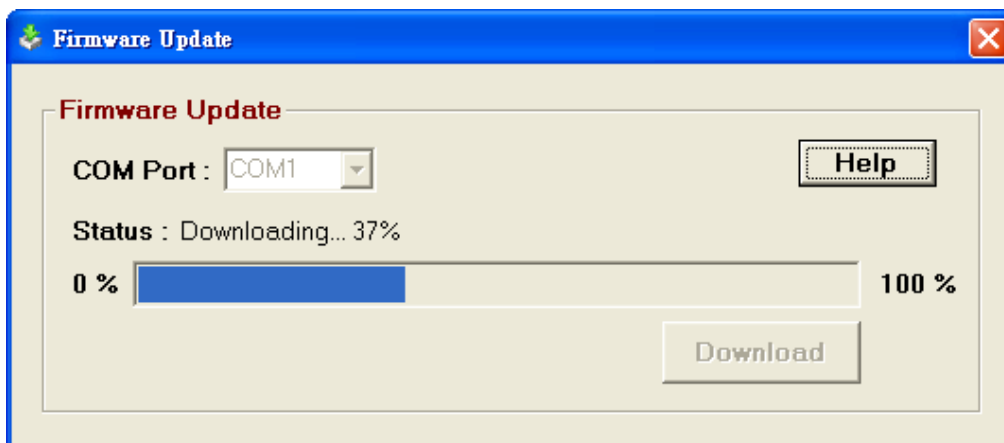

Fig 5.5-5 Firmware Update Process

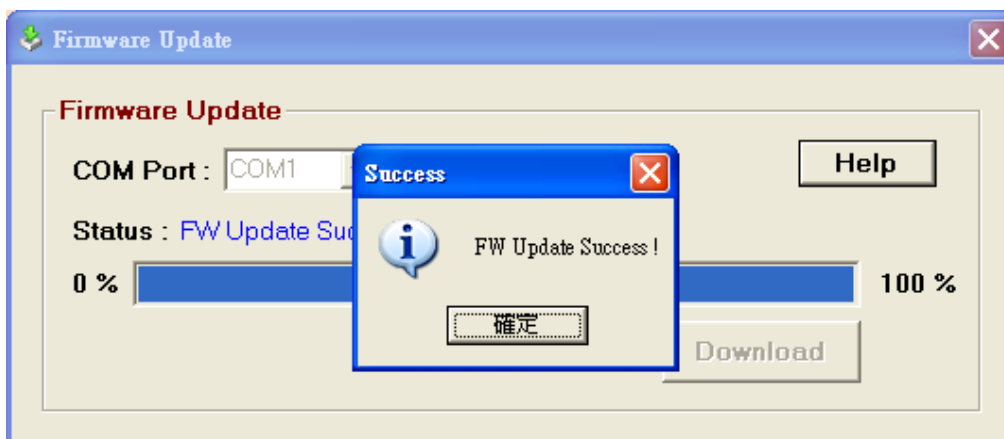

Fig 5.5-6 Firmware Update Success

In the last, please follow the steps 8~10 to reboot SAR-713 and finish the firmware update process.

[Note]

1. The firmware of SAR-713 can be also updated via Ethernet and the detailed steps please refer to the third item of section 9.1 – “Update Firmware via Ethernet”.

5.6 Stream Data

Click “Configuration” item in the menu bar and choose “Stream Data” function like Fig 5.6-1. The Stream Data screen will be opened like Fig 5.6-2.

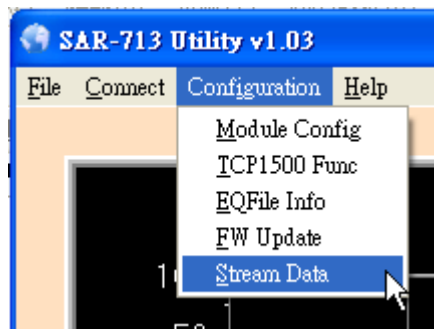

Figure 5.6-1 Open “Stream Data” Screen

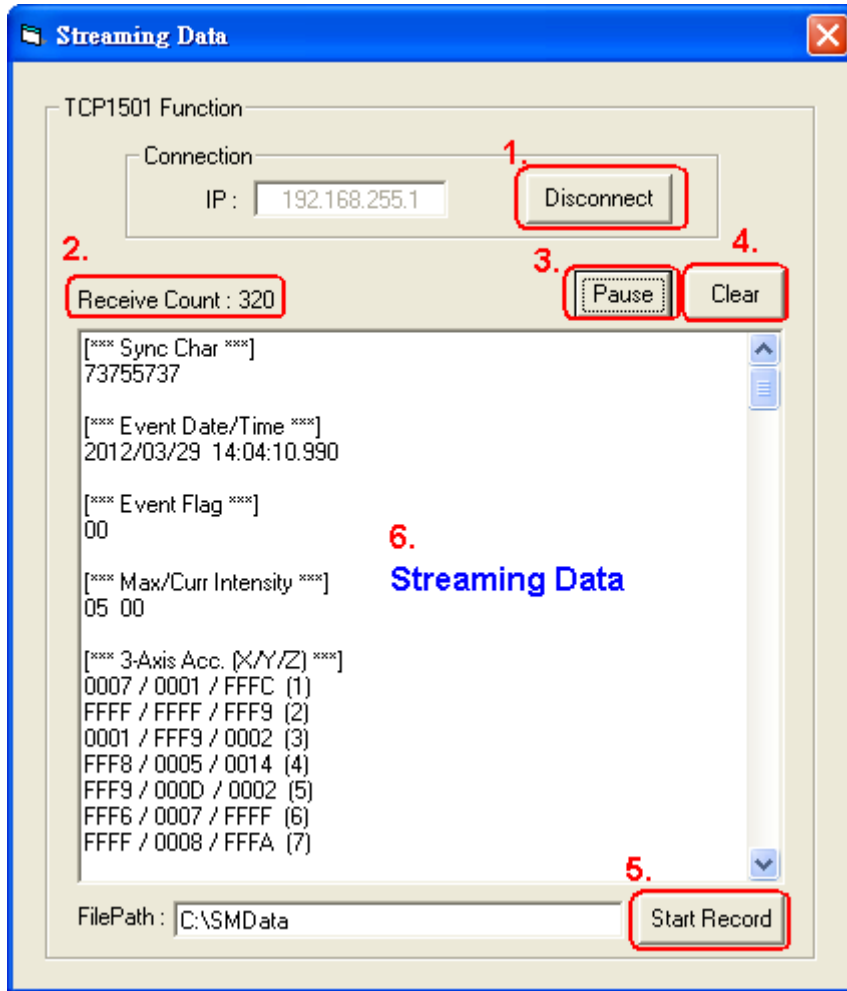

Figure 5.6-2 Stream Data Screen

The following is the detailed function description :

(1) **“Connect”** button :

Type IP address of SAR-713 in the “IP” field and click “Connect” button to connect to the TCP Server (**Port 1501**). If the connection is successful, the message, “Port1501_Connected”, will show in the below field like Figure 5.6-3.

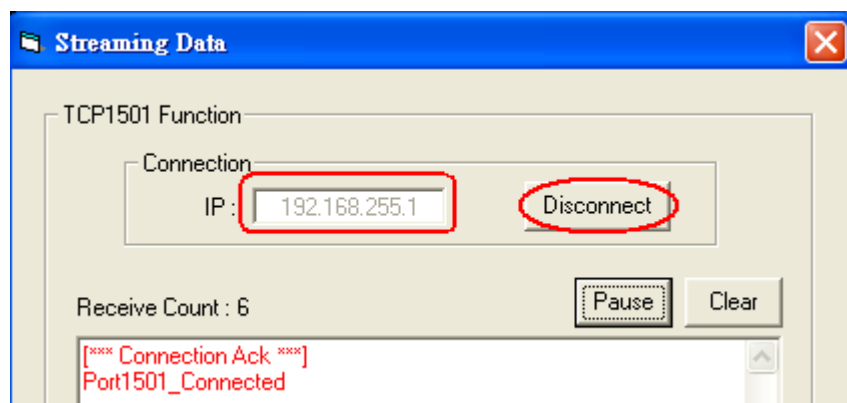

Figure 5.6-3 Connect to the TCP1501 Server

(2) **Receive Count** :

Show the total count of the received "Streaming Data".

(3) **"Pause"** button :

Used to pause updating the content of "Streaming Data" field. But the "Streaming Data" will be still received.

(4) **"Clear"** button :

Used to clear the content of "Streaming Data" field and reset the "Receive Count" value.

(5) **"Start Record"** button :

Enable the "Stream Data" file saving function (TXT File Format) and the filename consists of date and time of host. These "Stream Data" files will be saved in the path assigned by "File Path" field.

(6) **"Streaming Data"** Field :

Show the content of the received Streaming Data.

5.7 EQVoice File

In Utility_v1.04 or newer, add "EQVoice File" option in the "Configuration" item of the menu bar like Fig 5.7-1. The "Seismic Intensity Voice Setting" screen will be opened like Fig 5.7-2.

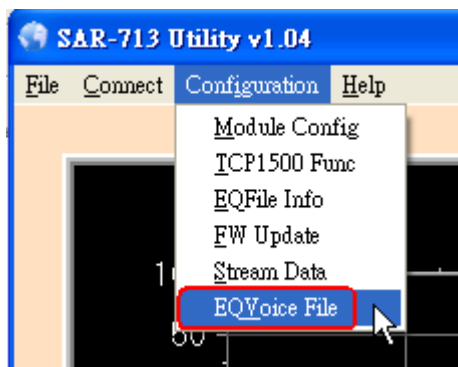

Figure 5.7-1 Open "EQVoice File" Screen

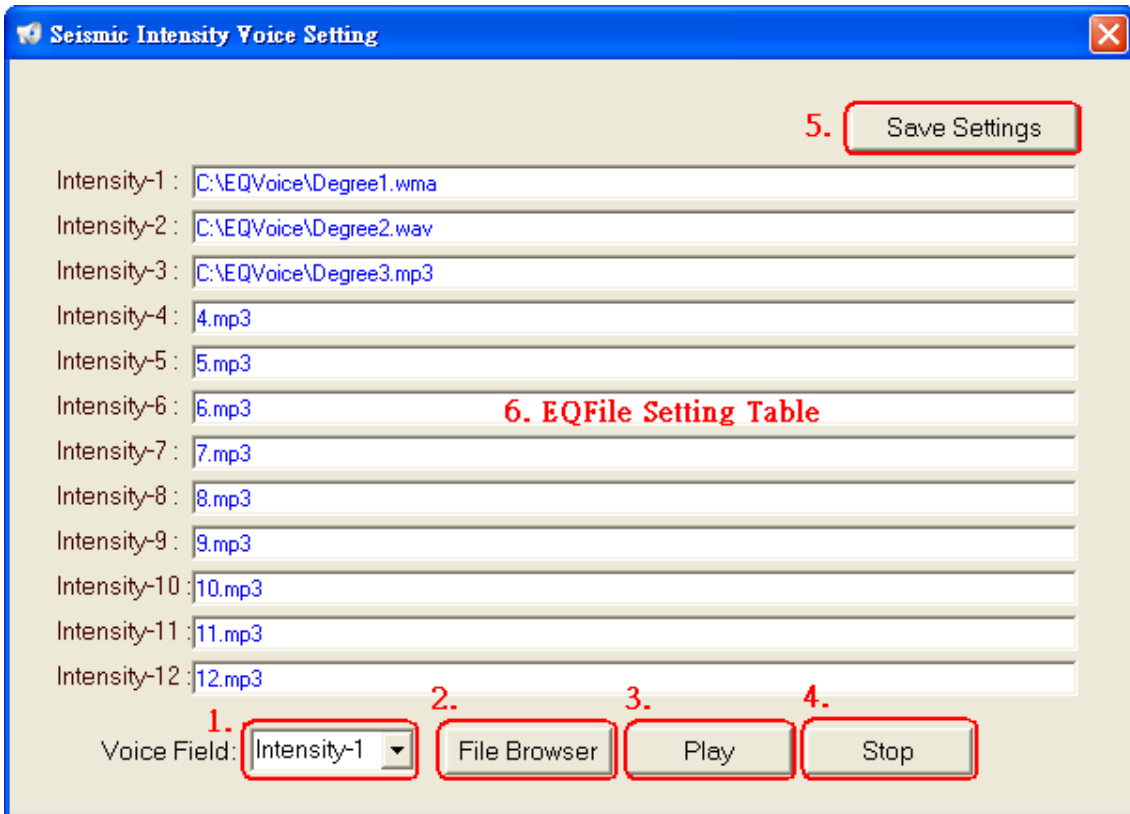

Figure 5.7-2 “Seismic Intensity Voice Setting” screen

The following is the detailed function description.

- (1) “Voice” option : Choose the voice file field of the assigned intensity range from 1 to 12.
- (2) “File Browser” button : Choose the voice file (*.wma, *.wav, *.mp3) of the assigned intensity.
- (3) “Play” button : Play the voice file of the assigned intensity.
- (4) “Stop” button : Stop playing the current voice file.
- (5) “Save Setting” button : Save the voice file settings to file, SysSettings.ini, saved in the same folder of SAR-713 utility.
- (6) EQFile Setting Table : Show the content of the seismic voice files.

[Note]

- 1. After finishing the setting of seismic alarm voice file, when earthquake happened, the assigned voice file of the current maximum intensity will be played.

6. TCP1500 Function :

TCP server with port 1500 (TCP1500) is provided by SAR-713 to extend the extra function like earthquake file operation, get hardware serial number etc. The following is the command format and function description for TCP server 1500.

[TCP1500 Command Format]

TCPFuncXX : Par1 : Par2 : Par3 :

TCPFuncXX => Command No. (Like: TCPFunc01)

Par1, Par2, Par3 => Command Parameters (Distinguished by usnig ":",")

[1. Earthquake Files Function]

TCPFunc01 => Show all file info of the assigned DiskNo

(Like: **TCPFunc01 : A** => Show all files info of DiskA)

(Like: **TCPFunc01 : B** => Show all files info of DiskB)

TCPFunc02 => Return the assigned earthquake file

(Like: **TCPFunc02 : A : 101224143010** => Return earthquake file of DiskA recorded in 2010/12/24 14:30:10)

TCPFunc03 => Return all earthquake files of the assigned DiskNo

(Like: **TCPFunc03 : A** => Return all files of DiskA)

TCPFunc04 => Delete the assigned earthquake file

(Like: **TCPFunc04 : B : 101224143010** => Delete earthquake file of DiskA recorded in 2010/12/24 14:30:10)

TCPFunc05 => Delete all earthquake files of the assigned DiskNo

(Like: **TCPFunc05 : A** => Delete all files of DiskA)

TCPFunc06 => Delete all earthquake files of Flash

(Like: **TCPFunc06** => Delete all files of Disk A and Disk B)

<Note>

Earthquake files are saved in Flash memory of SAR-713 and its filename format consists of year, month, day, hour, minute and second like 101224143010 without extension file name. So the earthquake file - 101224143010 means saved in 2010/12/24 14:30:10.

[2. TCP Information Function]

TCPFunc11 : Return all Modbus Client Host IP Address.

[3. Module Hardware Information Function]

TCPFunc21 : Return 64bit hardware serial number of SAR-713.

7. Factory Default Value :

The below table is the factory default value of SAR-713 and they will be saved in EEPROM. Users can write 6 in MB addr 013 or trig DI-1 for 3 seconds continuously to execute this function.

7.1 Factory Default Value Table

SAR-713 Default Value Table				
Addr Offset (DEC)	Addr Offset (HEX)	R/W	Label	Default Value
005	0x05	R	X_Acc_Offset	0 (Unit: Count)
006	0x06	R	Y_Acc_Offset	0 (Unit: Count)
007	0x07	R	Z_Acc_Offset	-16384 (Unit: Count)
014	0x0E	RW	Time_Zone_Diff	8 (Taiwan)
015	0x0F	RW	STA_Time	200 (Unit: 10ms)
016	0x10	RW	LTA_Time	2000 (Unit: 10ms)
017	0x11	RW	STA/LTA_Lev	3
018	0x12	RW	OP_Mode	0x54 (01010100b)
020	0x14	RW	EQ_Event_Time	3000 (Unit: 10ms)
022	0x16	RW	Zero_Records	200 (Count)
023	0x17	RW	DO0_Limit	20 (Unit: gal)
024	0x18	RW	DO1_Limit	80 (Unit: gal)
026	0x1A	RW	NTP_Update_Time	5 (Unit: Minute)
027	0x1B	RW	NTP_Server_No	1 (NTP Server 1)
035	0x23	RW	EQ_Data_RecFlag	0 (Disabled)
036	0x24	RW	EQ_Data_BlkJNo	0 (Flash - Disk A)
038	0x26	RW	EQ_BlkJFullFunc	0 (Cover the oldest file mode)
039	0x27	RW	Stream_Data_Ctrl	0 (Disabled)
059	0x3B	RW	NTPSvr2_IP1	192
060	0x3C	RW	NTPSvr2_IP2	43
061	0x3D	RW	NTPSvr2_IP3	244
062	0x3E	RW	NTPSvr2_IP4	18

SAR-713 Default Value Table				
063	0x3F	RW	Pre-EvtTime	0 (Unit: 10ms)
064	0x40	RW	Post-EvtTime	0 (Unit: 10ms)
066	0x42	RW	EQ_TotalCnt	0
067	0x43	RW	X_Pulse_Filter	16384 (Unit: count)
068	0x44	RW	Y_Pulse_Filter	16384 (Unit: count)
069	0x45	RW	Z_Pulse_Filter	16384 (Unit: count)
071	0x47	RW	NTPSvr_IP1	59
072	0x48	RW	NTPSvr_IP2	124
073	0x49	RW	NTPSvr_IP3	196
074	0x4A	RW	NTPSvr_IP4	84
076	0x4C	RW	TCPSvr_IP1	192
077	0x4D	RW	TCPSvr_IP2	168
078	0x4E	RW	TCPSvr_IP3	255
079	0x4F	RW	TCPSvr_IP4	2
080	0x50	RW	IP1	192
081	0x51	RW	IP2	168
082	0x52	RW	IP3	255
083	0x53	RW	IP4	1
084	0x54	RW	Mask1	255
085	0x55	RW	Mask2	255
086	0x56	RW	Mask3	0
087	0x57	RW	Mask4	0
088	0x58	RW	Gateway1	192
089	0x59	RW	Gateway2	168
090	0x5A	RW	Gateway3	255
091	0x5B	RW	Gateway4	254
093	0x5D	RW	Server_Period	10 (Unit:: 10ms)
094	0x5E	RW	MB/TCP/RTU_Server_Station_Number	1
098	0x62	RW	Axis_Mapping	0 (Horizontal Installation)
100	0x64	RW	Serial_No	0
101	0x65	RW	Filter_StartIP1	192
102	0x66	RW	Filter_StartIP2	168

SAR-713 Default Value Table				
103	0x67	RW	Filter_StartIP3	255
104	0x68	RW	Filter_StartIP4	1
105	0x69	RW	Filter_EndIP1	192
106	0x6A	RW	Filter_EndIP2	168
107	0x6B	RW	Filter_EndIP3	255
108	0x6C	RW	Filter_EndIP4	255
109	0x6D	R/W	Intensity_StdOpt	0 (China Intensity Scale)
110	0x6E	R/W	Intensity_CalOpt	0 (3-axial vector)

8. Direction Definition of X, Y, Z Axis :

No matter the installation of SAR-713 is horizontal or vertical and the tri-axial direction definition is the same like Fig 8-1. X axis is in the right side, Y axis is in the front side and Z axis is in the down side of SAR-713 module.

[Note]

1. After the installation of SAR-713 is completed, users need to set the value of MB addr 098. When the value is 0, it is used for horizontal installation of SAR-713. When the value is 1, it is used for vertical installation of SAR-713.

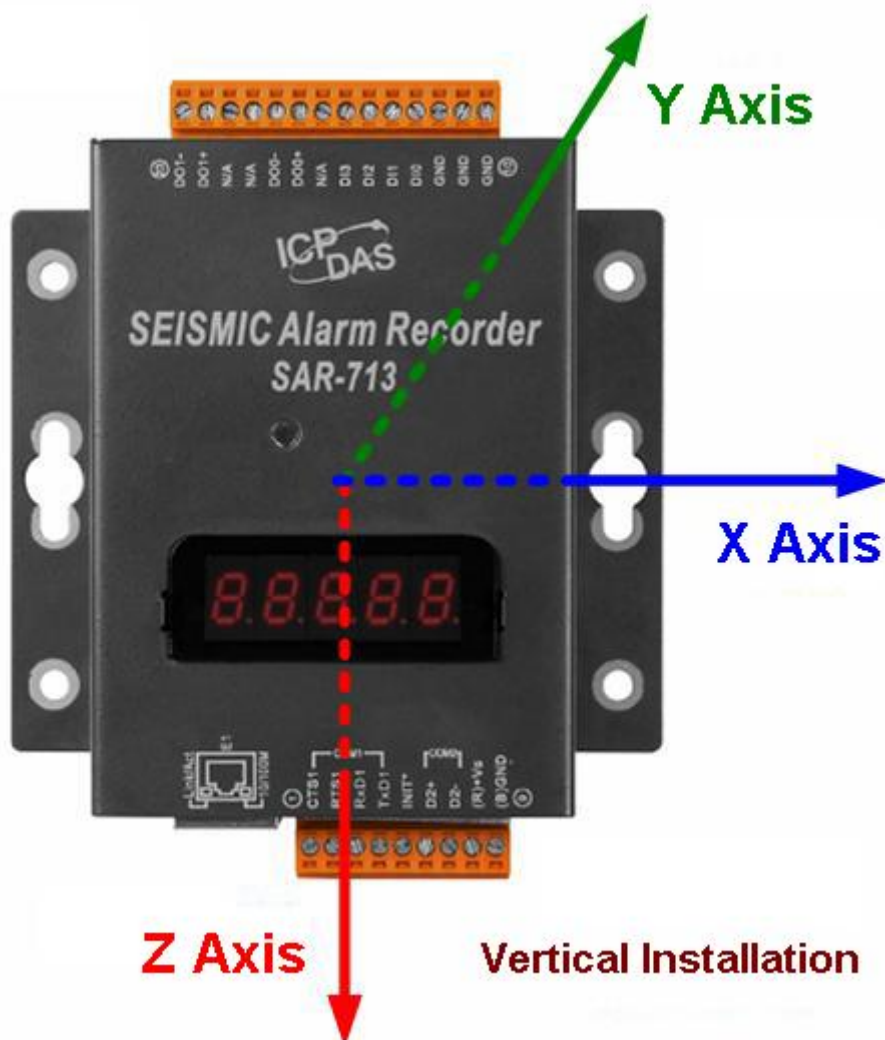

Fig 8-1 Tri-axial Direction Definition of SAR-713

9. FAQ :

9.1 How to scan all SAR-713 modules in LAN ?

Users can use the free MiniOS7 utility provided by ICP DAS (Download : ftp://ftp.icpdas.com/pub/cd/8000cd/napdos/minios7/utility/minios7_utility/) to scan all SAR-713 modules and update firmware. The following is the detailed description.

<1. Scan all SAR-713 modules >

- (1) Execute MiniOS7 Utility
- (2) Click the “arrow” button in the right side of "Connection" button and choose the “Search” function. It will start to scan all SAR-713 modules automatically like Fig 9.1-1 and the result will show in the list table like Fig 9.1-2.

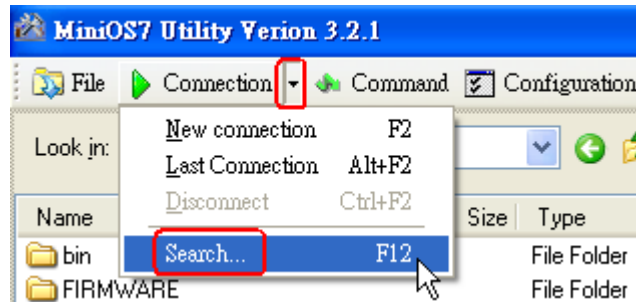
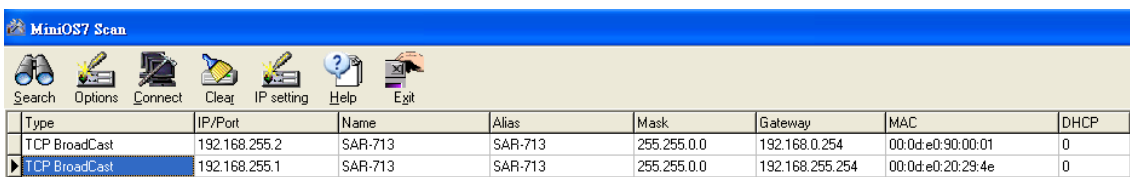

Fig 9.1-1 Search Function

The screenshot shows the MiniOS7 Scan window. The window title is 'MiniOS7 Scan'. The interface includes a toolbar with icons for Search, Options, Connect, Clear, IP setting, Help, and Exit. Below the toolbar is a table with the following data:

Type	IP/Port	Name	Alias	Mask	Gateway	MAC	DHCP
TCP BroadCast	192.168.255.2	SAR-713	SAR-713	255.255.0.0	192.168.0.254	00:0d:e0:90:00:01	0
TCP BroadCast	192.168.255.1	SAR-713	SAR-713	255.255.0.0	192.168.255.254	00:0d:e0:20:29:4e	0

Fig 9.1-2 Search List Table

<2. Modify IP address of the Assigned SAR-713 >

- (1) Choose the assigned SAR-713 module and click the “IP setting” button. It will open the network parameter setting screen like Fig 9.1-3 and remember to click “Set” button to enable the modification.

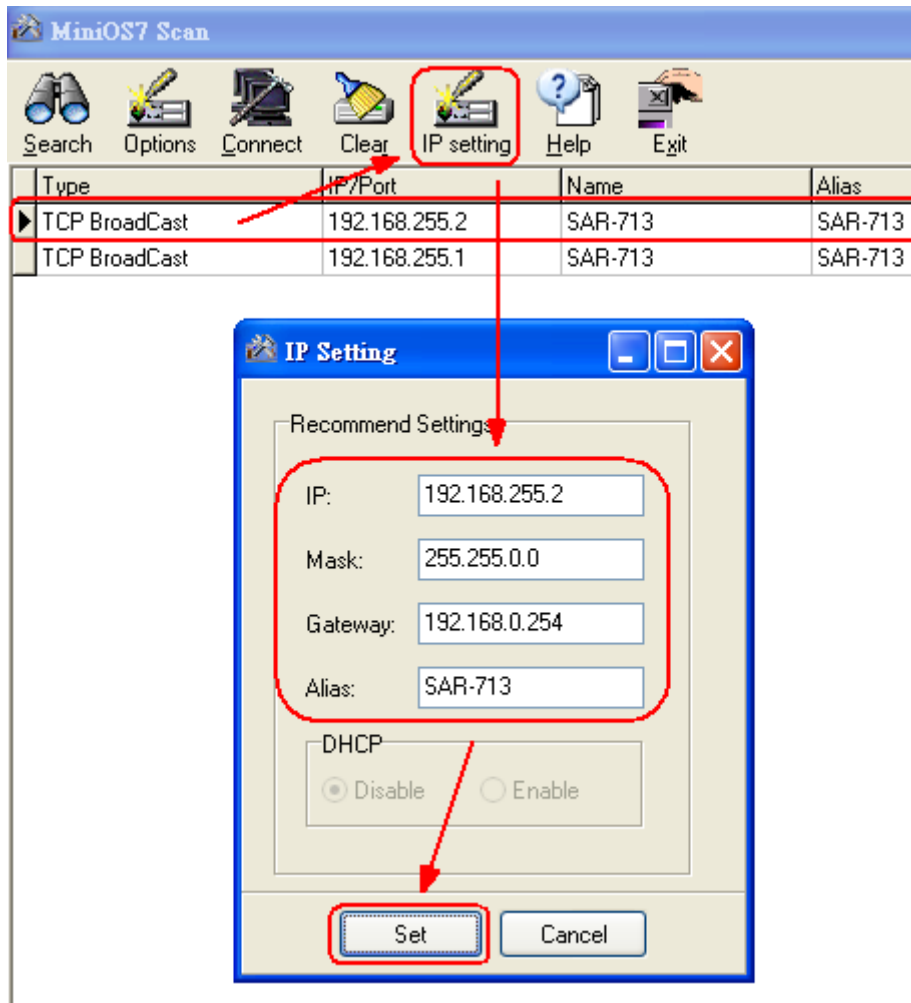

Fig 9.1-3 Network Parameter Setting

<3. Update Firmware via Ethernet >

- (1) Choose the assigned SAR-713 module and click the “Connect” button like Fig 9.1-4. It will open the connection screen and show the internal firmware files in the right field like Fig 9.1-5.

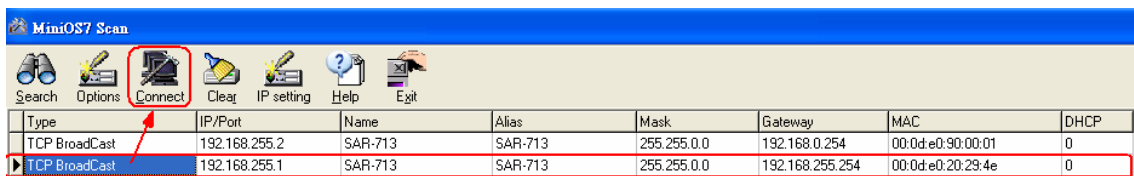

Fig 9.1-4 Open Connection Screen

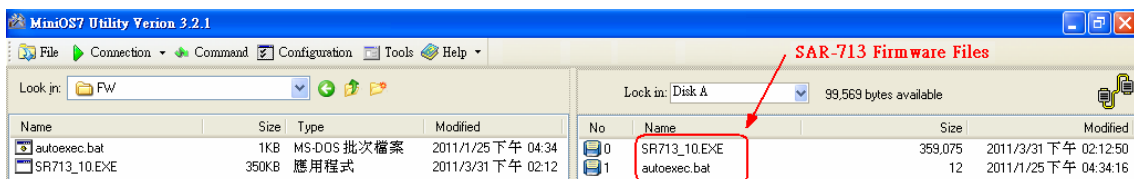

Fig 9.1-5 Firmware Files

- (2) Click "Command" button and choose "Erase Disk" function. It will show the "Confirm" message and click "Yes" button to delete firmware files of SAR-713 like Fig 9.1-6.

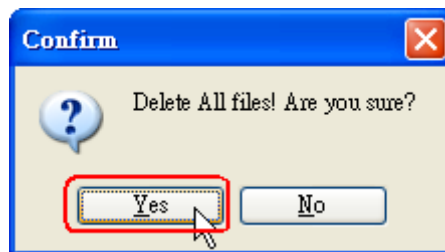
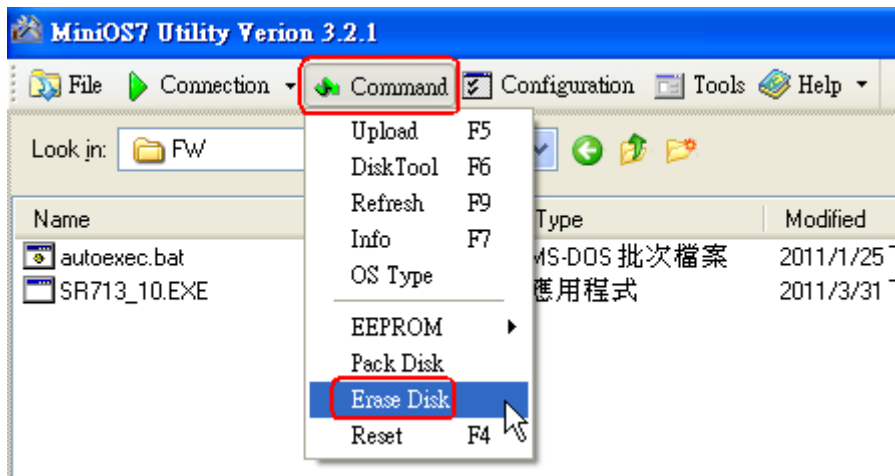

Fig 9.1-6 "Erase Disk" Function

- (3) Choose firmware files of SAR-713 including "autoexec.bat" and "SR713_10.EXE" files and click right button of mouse to choose the "Upload" function. Then it will start the firmware upload process like Fig 9.1-7.



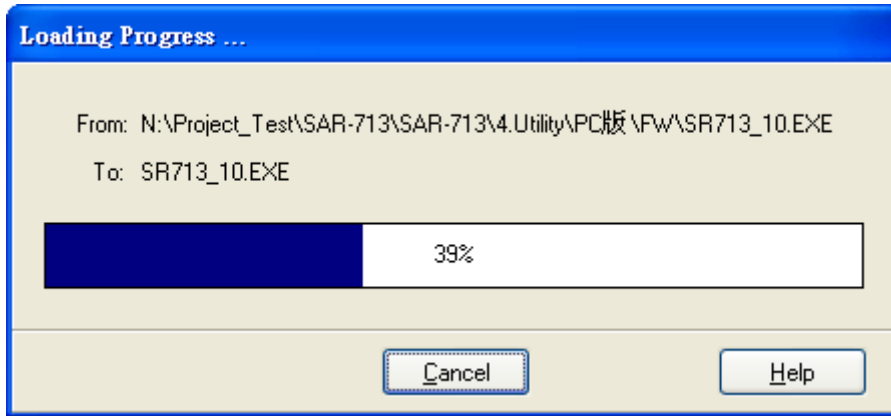

Fig 9.1-7 Firmware Upload

(4) After firmware upload finished, please reboot SAR-713 to complete the firmware update process. Users can also click “Reset” button to reboot SAR-713 like Fig 9.1-8.

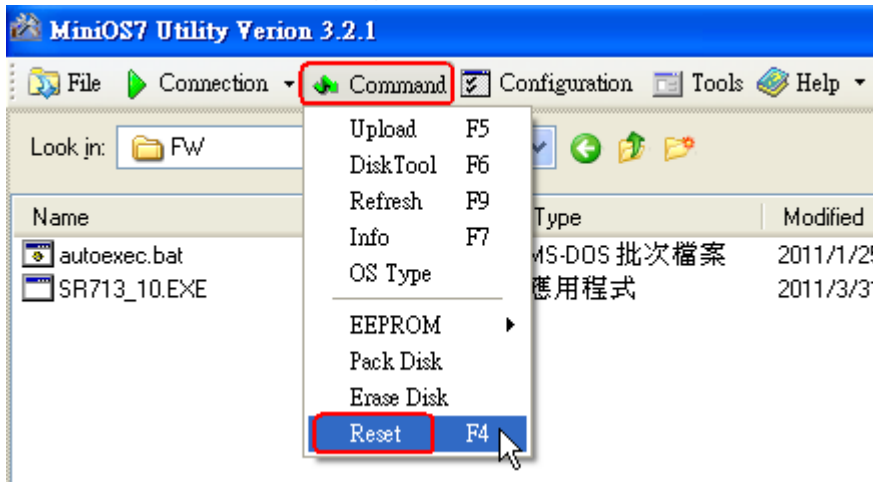

Fig 9.1-8 "Reset" function of SAR-713

9.2 Trend Update Pause Problem of SAR-713 Utility

When connecting to SAR-713 by using MB/TCP or MB/RTU client communication, if pause condition happened in trend, please check if the TCP server function is enabled by checking the bit 3 of MB addr 018. If the bit is 1, it means TCP server function is enabled and set the bit to be 0 to solve this problem.

10. Version

Version	Author	Date	Description
1.00	Edward	2011/06/29	1. First Version.
1.01	Edward	2012/01/03	1. In Utility v1.02, add "Export EQFile (*.bin) to Excel" Function.
1.02	Edward	2012/03/29	1. Add "Streaming Data Control" function in FW v1.02 or newer.
1.03	Edward	2012/05/21	1. Add "Pulse Filter" function of 3-axis acceleration in FW v1.03 or newer. 2. Improve "Streaming Data" function timer accuracy in FW v1.03 or newer.
1.04	Edward	2012/07/12	<p>[FW_v1.04 New Features]</p> <p>1. Modify the calculation method of STA/LTA and up to the bit 2 setting of MB Addr 18.</p> <p>2. Add "Extended Intensity Standard Option" (MB Addr 109)</p> <p>3. Add "Extended Intensity Calculation Mode Option" (MB Addr 110)</p> <p>4. Add "Intensity Degree Value" (MB Addr 111)</p> <p>5. Add "Modified Mercalli Intensity" (MMI) scale.</p> <p>6. Add "JMA" Intensity scale.</p> <p>[Utility_v1.04 New Features]</p> <p>1. Add "Seismic Alarm Voice Playing Function".</p>
1.06	Edward	2015/01/22	<p>[FW_v1.06 New Features]</p> <p>1. Add "Socket Auto-Disconnection" function to solve SAR-713 unable connection issue. Users need to add "/W" parameter in autoexec.bat file first. (Example: /W300 means if there is no any communication in 300 seconds, the SAR-713 will disconnect the socket automatically.</p>
1.07	Edward	2015/02/06	<p>[FW_v1.07 New Features]</p> <p>1. Add the b0 function of "MBAddr 112".</p> <p>2. Add the b8 function of "MBAddr 018".</p>

Appendix 1: Earthquake Intensity Table of Taiwan

Intensity Scale		Ground Acceleration (cm/s ² ,gal)
0		0.8 Below
1	Very Minor	0.8~2.5
2	Minor	2.5~8.0
3	Light	8~25
4	Moderate	25~80
5	Strong	80~250
6	Very Strong	250~400
7	Great	400 Above
Note : 1gal = 1cm/sec ²		

Appendix 2: Earthquake Intensity Table of China

Intensity	Earthquake Effects
1	No felt
2	Felt only by persons at rest
3	Felt by persons indoors only
4	Felt by persons indoors only
5	Felt by all; some damage to plaster, chimneys
6	Felt by all; some damage to plaster, chimneys
7	People run outdoors, damage to poorly built structures
8	Well-built structure slightly damaged; poorly built structures suffer major damage
9	Buildings shifted off foundations
10	Some well-built structures destroyed
11	Few masonry structures remain standing; bridges destroyed
12	Damage total; waves seen on ground; objects thrown into air

Appendix 3: Modified Mercalli Intensity Scale

- I. Not felt except by a very few under especially favorable conditions.
- II. Felt only by a few persons at rest, especially on upper floors of buildings.
Felt quite noticeably by persons indoors, especially on upper floors of buildings. Many people do not recognize it as an earthquake. Standing motor cars may rock slightly. Vibrations similar to the passing of a truck. Duration estimated.
- III. Felt indoors by many, outdoors by few during the day. At night, some awakened.
- IV. Dishes, windows, doors disturbed; walls make cracking sound. Sensation like heavy truck striking building. Standing motor cars rocked noticeably.
- V. Felt by nearly everyone; many awakened. Some dishes, windows broken. Unstable objects overturned. Pendulum clocks may stop.
- VI. Felt by all, many frightened. Some heavy furniture moved; a few instances of fallen plaster. Damage slight.
Damage negligible in buildings of good design and construction; slight to moderate in well-built ordinary structures; considerable damage in poorly built or badly designed structures; some chimneys broken.
- VII. Damage slight in specially designed structures; considerable damage in ordinary substantial buildings with partial collapse. Damage great in poorly built structures. Fall of chimneys, factory stacks, columns, monuments, walls. Heavy furniture overturned.
- VIII. Damage considerable in specially designed structures; well-designed frame structures thrown out of plumb. Damage great in substantial buildings, with partial collapse. Buildings shifted off foundations.
- IX. Some well-built wooden structures destroyed; most masonry and frame structures destroyed with foundations. Rails bent.
- X. Few, if any (masonry) structures remain standing. Bridges destroyed. Rails bent greatly.
- XI. Damage total. Lines of sight and level are distorted. Objects thrown into the air.

Appendix 4: JMA Intensity Scale

Shindo / Meter reading	People	Indoor situations
0 (0) / 0–0.4	Imperceptible to people.	
1 (1) / 0.5–1.4	Felt by only some people indoors.	
2 (2) / 1.5–2.4	Felt by most people indoors. Some people awake.	Hanging objects such as lamps swing slightly.
3 (3) / 2.5–3.4	Felt by most people indoors. Some people are frightened.	Dishes in a cupboard rattle occasionally.
4 (4) / 3.5–4.4	Many people are frightened. Some people try to escape from danger. Most sleeping people awake.	Hanging objects swing considerably and dishes in a cupboard rattle. Unstable ornaments fall occasionally.
5-lower / 4.5–4.9	Most people try to escape from a danger. Some people find it difficult to move.	Hanging objects swing violently. Most unstable ornaments fall. Occasionally, dishes in a cupboard and books on a bookshelf fall and furniture moves.
5-upper / 5.0–5.4	Many people are considerably frightened and find it difficult to move.	Most dishes in a cupboard and most books on a bookshelf fall. Occasionally, a TV set on a rack falls, heavy furniture such as a chest of drawers fall, sliding doors slip out of their groove and the deformation of door frames makes it impossible to open doors.
6-lower / 5.5–5.9	Difficult to keep standing.	A lot of heavy and unfixed furniture moves and falls. It is impossible to open the door in many cases.
6-upper / 6.0–6.4	Impossible to keep standing and to move without crawling.	Most heavy and unfixed furniture moves and falls. Occasionally, sliding doors are thrown from their groove.
7 (7) / 6.5 and up	Thrown by the shaking and impossible to move at will.	Most furniture moves to a large extent and some jumps up.

Appendix 5 : Unit Conversion

The following is the unit conversion for acceleration used by SAR-713.

(1) 1 g = 980 cm/s² = 980 gal

1 mg = 0.98 gal

(2) 1 gal = 16.718 count

1 mg = 16.384 count