

3GHD-OE 3GHD-OE-2

Single and dual 3G-SDI
optical to electrical converter

User manual

Rev. 5

Nezion Support

Nezion Europe

P.O. Box 1020
3204 Sandefjord, Norway

Support phone 1: +47 33 48 99 97
Support phone 2: +47 90 60 99 99

Nezion USA

1600 Emerson Avenue
Oxnard, CA 93033, USA

Toll free North America: (866) 515-0811
Outside North America: +1 (805) 247-8560

E-mail: support@nezion.com

See <http://www.nezion.com/support/> for service hours for customer support globally.

Revision history

Current revision of this document is the uppermost in the table below.

Rev.	Repl.	Date	Sign	Change description
5	4	2012-06-12	AJM	Updated chapter 3.5. and 6.1.1
4	3	2012-01-20	AJM	Added MADl transport chapter.
3	2	2011-10-19	AJM	Changed optical overload.
2	1	2010-03-09	AJM	Updated DIP 5 in 3.2
1	0	2009-10-23	AJM	Updated DIP 2, 4 and 6 in 3.2.
0	-	2009-05-15	AJM	First release.

Contents

- 1 Product overview 4
 - 1.1 Product versions..... 5
- 2 Specifications 6
 - 2.1 General 6
 - 2.2 Optical Input 6
 - 2.3 Electrical Outputs 6
 - 2.4 Standards..... 6
- 3 Configuration 7
 - 3.1 Single converter 7
 - 3.2 Dual converter 8
 - 3.3 Reclocker mode 9
 - 3.4 Display optical input power (long-haul version only) 9
 - 3.5 Automatic change over 10
 - 3.6 Single converter configuration example 10
 - 3.7 Dual converter configuration example..... 11
- 4 MADI transport 12
- 5 Connections..... 13
 - 5.1 Mounting the connector module..... 13
 - 5.2 Terminal format support..... 13
- 6 Module status 15
 - 6.1 GPI ALARM – Module Status Outputs 15
 - 6.2 Front panel – Status monitoring 16
- 7 RS422 commands 17
 - 7.1 FLP4.0 block commands 17
 - 7.2 Single converter 18
 - 7.3 Dual converter 18
- General environmental requirements for Nevion equipment..... 20
- Product Warranty..... 21
- Appendix A Materials declaration and recycling information..... 22
- EC Declaration of Conformity 23

1 Product overview

The Flashlink 3GHD-OE and 3GHD-OE-2 is a dual multi bit-rate optical to electrical converter module providing high performance media conversion for various signal formats from 19.4Mbps up to 2970Mbps. Unmatched signal accuracy, even in critical applications with pathological signal patterns makes the 3GHD-OE and 3GHD-OE-2 the first choice for all optical transport demands.

The 3GHD-OE- and 3GHD-OE-2 can transport all HD and SD signal formats in addition to DVB-ASI and SMPTE 310M. It performs optical refreshing and signal re-clocking, which is selectable on application. The optical input comes with a sophisticated PIN diode with a sensitivity typically better than -20dBm operating in the 1200-1620nm wavelength range. The module is also available as a long-haul version with typically -30dBm sensitivity. The open system platform of Nevision Flashlink system allows easy interoperability with third party fibre optical systems.

The 3GHD-OE and 3GHD-OE-2 unit has also three electrical outputs for each converter, which reduces the need for additional DA's

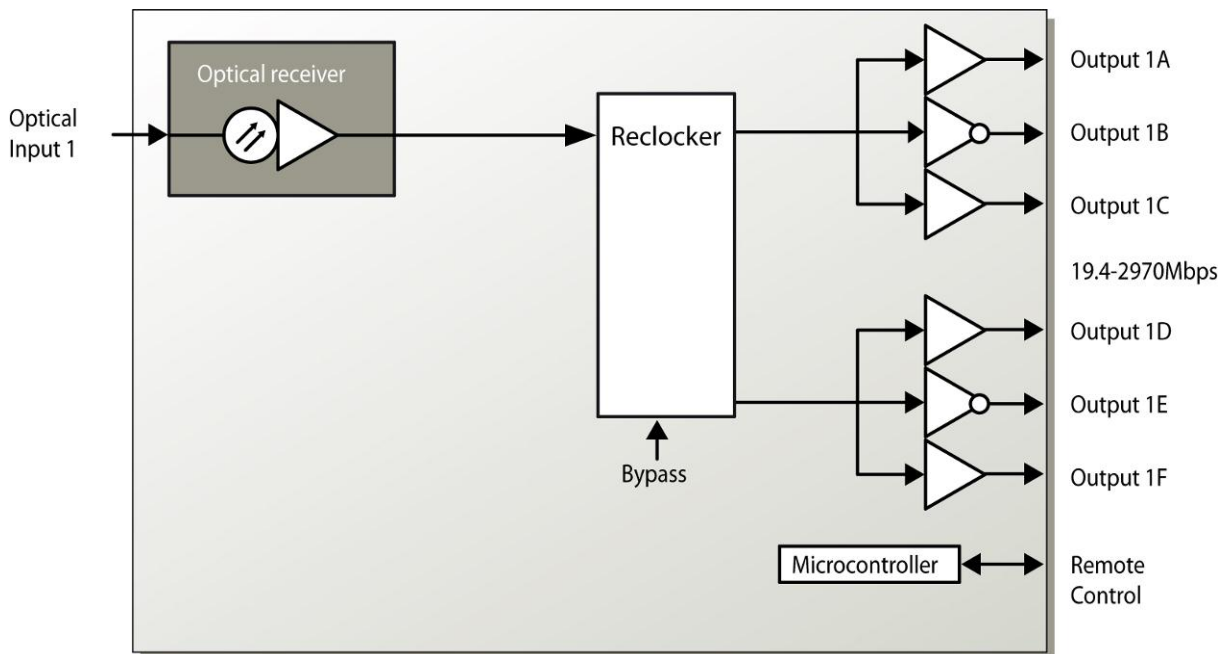

Figure 1 Block diagram of the 3GHD-OE converter

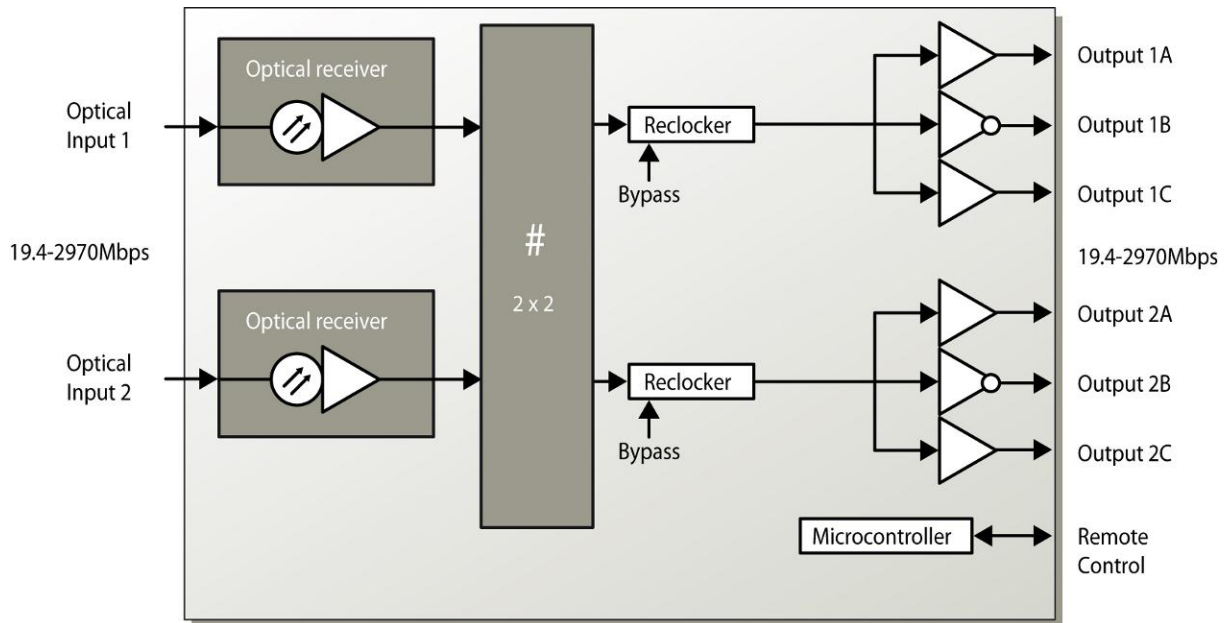

Figure 2 Block diagram of the 3GHD-OE-2 converter

1.1 Product versions

Available in the following versions:

3GHD-OE	Single converter
3GHD-OE long haul	Single converter, long haul
3GHD-OE-2	Dual converter
3GHD-OE-2 long haul	Dual converter, long haul

2 Specifications

2.1 General

Power	+5V DC / 3.2W, max
Control	Control system for access to setup and module status with BITE (Built-In Test Equipment)
Temp. range	0 to +40 °C

2.2 Optical Input

Number of inputs	1 on single converter 2 on dual converter
Data rate optical	19.4 to 2970Mbps
Sensitivity short haul	-20dBm
Sensitivity long haul	-30dBm with laser extinction ratio >10:1 (DWDM) -28dBm (CWDM)
Input overload short haul	SD/HD: -3dBm, 3G: -5dBm
Input overload long haul	-7dBm
Detector damage threshold	>0dBm
Optical wavelength	1200–1620nm
Transmission circuit fiber	Single mode 9/125um
Connector return loss	>40dB w/SM fiber
Connector	SC/UPC

2.3 Electrical Outputs

Number of outputs	6 on single converter 3 (per converter) on the dual converter
Connector	BNC
Impedance	75 ohm
Return loss	>15dB @ 5-1485MHz >10dB 1485-2970MHz
Peak to peak signal level	800mV ± 100mV
Signal polarity	2 inverting, 4 non-inverting on single converter 2 inverting, 1 non-inverting (per converter) on dual converter

2.4 Standards

Supported standards for electrical and optical ports:

SMPTE292M, SMPTE259M, SMPTE297M, SMPTE305.2M, SMPTE310M, SMPTE424M, DVB-ASI EN50083-9

3 Configuration

3.1 Single converter

The 3GHD-OE can support a number of different broadcast formats. The correct configuration can either be set with a DIP switch or with the GYDA Control System. The layout of 3GHD-OE is shown in the drawing below with the DIP switch to the upper left position.

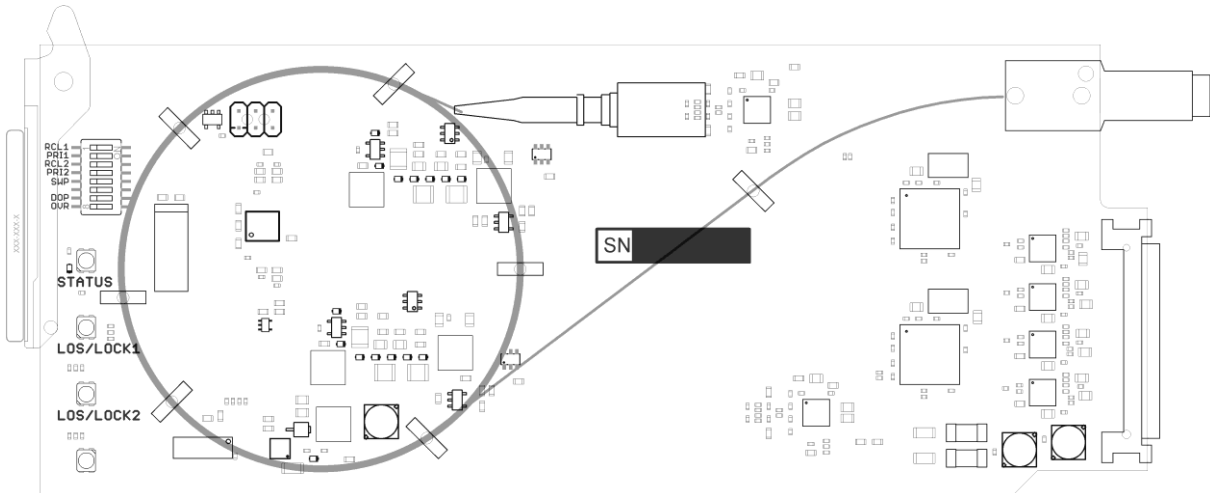

Figure 3 3GHD-OE board layout

Switch #	Label	Function, DIP = ON	Function, DIP = OFF	Comment
1	RCL1	Reclocker 1 ON	Reclocker 1 bypass	Reclocker mode for output 1
2	PRI1			No function on this product
3	RCL2			No function on this product
4	PRI2			No function on this product
5	SWP			No function on this product
6				
7	DOP	All LED showing optical input power	LED's normal operation	See 3.4 Display optical input power
8	OVR	Override GYDA control. Configuration with DIP switch	GYDA control. Configuration with GYDA	Select configuration from GYDA

All DIP switches are off when pointing towards the release handle.

3.2 Dual converter

The 3GHD-OE-2 can support a number of different broadcast formats. The correct configuration can either be set with a DIP switch or with the GYDA Control System. The layout of 3GHD-OE-2 is shown in the drawing below with the DIP switch to the upper left position.

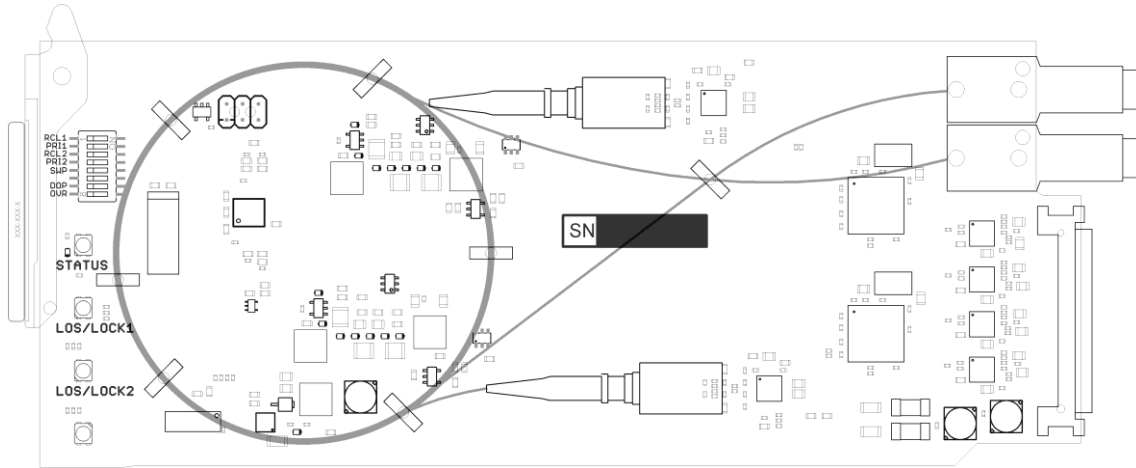

Figure 4 3GHD-OE-2 board layout

Switch #	Label	Function, DIP = ON	Function, DIP = OFF	Comment
1	RCL1	Reclocker 1 ON	Reclocker 1 bypass	Reclocker mode for output 1
2	PRI1	Select input 2	Select input 1	Selects input or in ACO mode selects main input for output 1
3	RCL2	Reclocker 2 ON	Reclocker 2 bypass	Reclocker mode for output 2
4	PRI2	Select input 2	Select input 1	Selects input or in ACO mode selects main input for output 2
5	SWP	Automatic change over	Normal operation	See chapter 3.5 Automatic change over
6		Select input 2	Select input 1	Selects input for DOP
7	DOP	All LED showing optical input power	LED's normal operation	See chapter 3.4 Display optical input power
8	OVR	Override GYDA control. Configuration with DIP switch	GYDA control. Configuration with GYDA	Select configuration from GYDA

All DIP switches are off when pointing towards the release handle.

3.3 Reclocker mode

The reclocker can be set to reclock or bypass from DIP#1 and DIP#3 or from GYDA.

When reclocker is set to reclock mode jitter from the signal is removed. Accepted bitrates is 270, 1483.5, 1485, 2967 and 2970Mbps.

When reclocker is set to bypass the converter accept all bitrates between 19.4 to 2970Mbps. Note that in this mode the jitter is not removed and this can cause problems for equipment following the converter.

3.3.1 Transparency

This converter only looks at the bitrates and not the content. This means that any signal with correct bitrates is converted. The product is transparent to data in the ancillary space like embedded audio.

3.4 Display optical input power (long-haul version only)

On the long haul version the LEDs can be used as an optical power meter. This is practical under installation of the module. The power measurement is not accurate but can be used as an indication of optical signal strength. Remember to turn this function of after installation. When all LEDs are green the optical input power is more than -6.5dBm. When all LED are off input power is below -25dBm.

The DOP can only be turned on from the DIP. DOP is turned on by DIP#7 and DIP#6 select input port.

Optical input power	Status LED	LOS/lock1 LED	LOS/lock2 LED	
More than -6.5dBm	Green	Green	Green	Green
-7.0dBm to -8.5dBm	Yellow	Green	Green	Green
-9.0dBm to -10.5dBm	Red	Green	Green	Green
-11.0dBm to -12.5dBm		Green	Green	Green
-13.0dBm to -14.5dBm		Yellow	Green	Green
-15.0dBm to -16.5dBm		Red	Green	Green
-17.0dBm to -18.0dBm			Green	Green
-18.5dBm to -19.0dBm			Yellow	Green
-19.5dBm to -20.0dBm			Red	Green
-21.0dBm to -22.0dBm				Green
-23.0dBm to -24.0dBm				Yellow
Below -25dBm				Red

3.5 Automatic change over

Dual optical converter has an automatic changeover module. This module has the possibility to have an automatic change over on the input. This can be used in redundancy systems where the user wants automatically switch to a backup port when the main input loses signal. This function can be turned with DIP#5. From GYDA this function can be turned on for each converter. Each converter can be configured to what is main and backup input by DIP#2 and DIP#4 or from GYDA.

3.5.1 Trigger condition

Loss of optical power trigs the automatic change over. When the main input loss optical power the backup input is selected. When the backup input is active an alarm is displayed in Gyda. When the main input optical power is restored the converter switches immediately back to main input and the alarm is restored.

Note that bit error or loss of lock on reclocker does not trigger the ACO.

3.6 Single converter configuration example

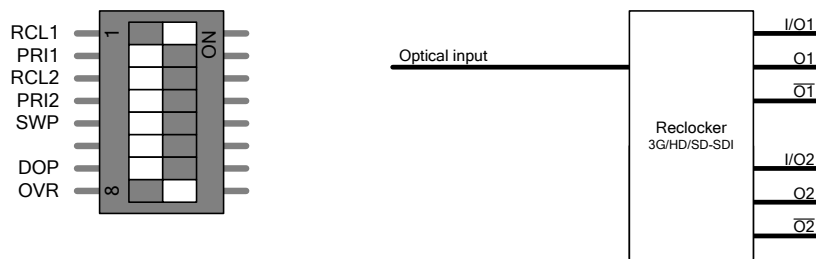

Figure 5 OE converter with reclocker

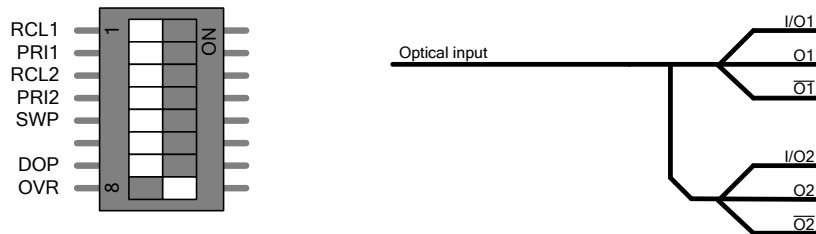

Figure 6 OE converter with reclocker in bypass

3.7 Dual converter configuration example

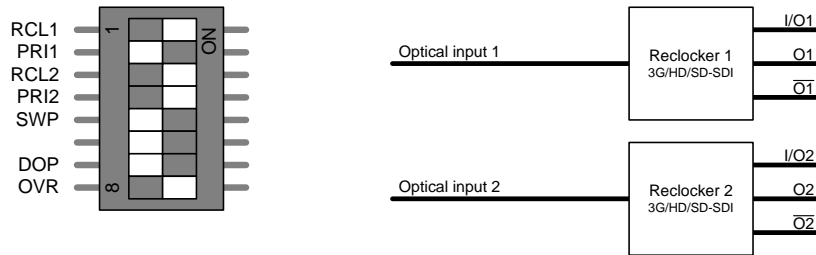

Figure 7 Dual OE converter, standard setup

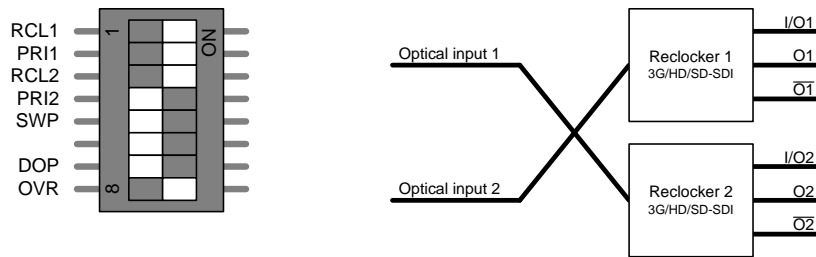

Figure 8 Dual OE converter, input swap

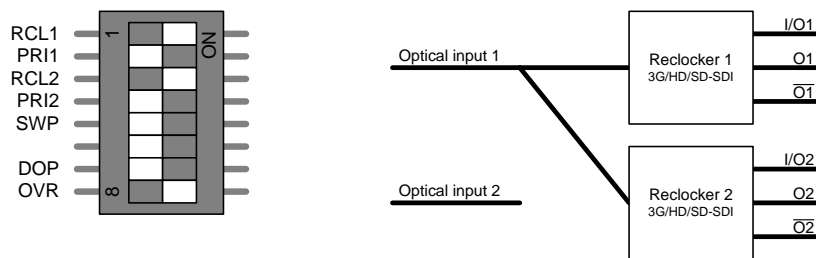

Figure 9 Single OE converter with DA, input 1

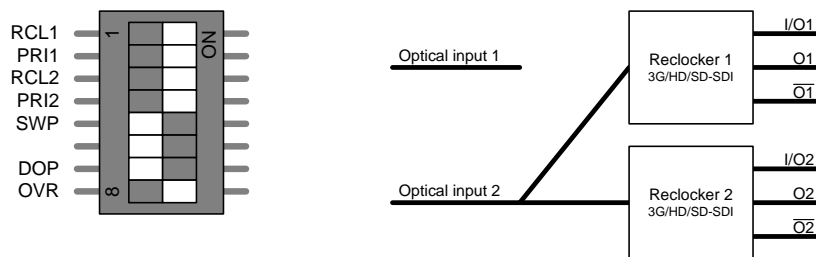

Figure 10 Single OE converter with DA, input 2

4 MADI transport

The card can be used to transport MADI signal. Neveion recommend setting the cable EQ and rec-clocker in bypass.

5 Connections

The 3GHD-OE and 3GHD-OE-2 has a dedicated connector module; 3GHD-EO-2-C1. This module is mounted at the rear of the sub-rack. The module is shown in the figure below.

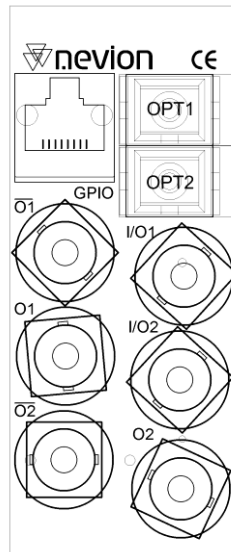

Figure 11 Connector module for 3GHD-OE-2

5.1 Mounting the connector module

The details of how the connector module is mounted, is found in the user manual for the sub-rack frame FR-2RU-10-2.

This manual is also available from our web site:

<http://www.nevion.com/>.

5.2 Terminal format support

The different input and output ports on 3GHD-OE and 3GHD-OE-2 can support a number of formats. The table below show which signal formats are supported on the selected terminals.

Terminal format support for single converter:

Terminal	Function	Supported Format	Mode
OPT1	Optical input	SDI, DVB-ASI, SMPTE310, Transparent	Input
OPT2	Not used.		
I/O1 I/O2 O1 O2	Electrical Output Reclocked DA output	SDI, DVB-ASI, Transparent	Output
$\overline{O1}$ $\overline{O2}$	Electrical Output Reclocked DA inverted output	SDI, Transparent	Output
GPI ALARM	Open Collector Alarms	Wired alarms	OC Output

Terminal format support for dual converter:

Terminal	Function	Supported Format	Mode
OPT1 OPT2	Optical output	SDI, DVB-ASI, SMPTE310, Transparent	Output
I/O1 I/O2 O1 O2	Electrical Output Reclocked DA output	SDI, DVB-ASI, Transparent	Output
$\overline{O1}$ $\overline{O2}$	Electrical Output Reclocked DA inverted output	SDI, Transparent	Output
GPI ALARM	Open Collector Alarms	Wired alarms	OC Output

Unused inputs should be terminated to avoid alarms triggered by noise.

6 Module status

The status of the module can be monitored in three ways.

1. GYDA System Controller (optional).
2. GPI at the rear of the sub-rack.
3. LED's at the front of the sub-rack.

Of these three, the GPI and the LED's are mounted on the module itself, whereas the GYDA System Controller is a separate module giving detailed information on the card status.

6.1 GPI ALARM – Module Status Outputs

These outputs can be used for wiring up alarms for third party control systems. The GPI outputs are open collector outputs, sinking to ground when an alarm is triggered. The GPI connector is shown in figures below.

Electrical Maximums for GPI outputs

Max current: 100mA

Max voltage: 30V

6.1.1 GPI connections

3GHD-OE-2 module GPI pinning:

Signal	Name	Pin #	Mode
Status	General error status for the module.	Pin 1	Open Collector This is normally closed.
LOS1	Loss of signal on input 1.	Pin 2	Open Collector
LOS2	Loss of signal on input 2.	Pin 3	Open Collector
Ground	0V / gnd pin.	Pin 8	0V.

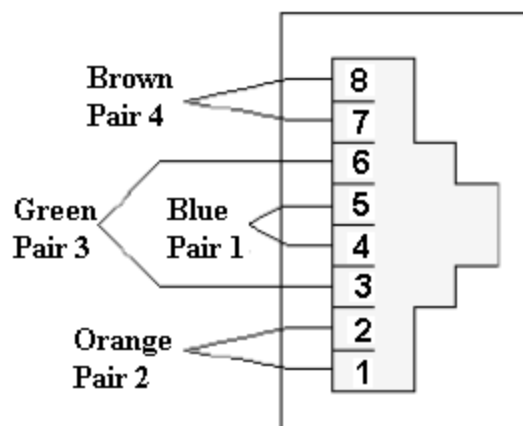
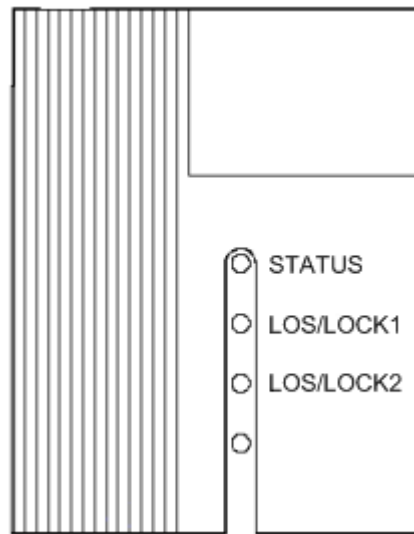

Figure 1 GPI connector

6.2 Front panel – Status monitoring

The status of the module can be easily monitored visually by the LED's at the front of the module. The LEDs are visible through the front panel as shown in the figure below.



The 3GHD-OE-2 has 4 LED's each showing a status corresponding to the GPI pinning. When DIP#7 is on the LEDs are used as an optical power meter.

Diode \ State	Red LED	Yellow LED	Green LED	No light
Status	Module is faulty, or module is initializing.	N/A	Module is OK Module power is OK	Module has no power
LOS/LOCK1	No input signal on electrical output 1.	Input signal on electrical output 1 but reclocker not in lock.	Input signal on electrical output 1 and reclocker in lock.	
LOS/LOCK2	No input signal on electrical output 2.	Input signal on electrical output 1 but reclocker not in lock.	Input signal on electrical output 1 and reclocker in lock.	

7 RS422 commands

This card uses the FLP 4.0 protocol to be configured and monitored. See separate documents for definition of this protocol.

7.1 FLP4.0 block commands

Common FLP4.0 block for both single and dual converter is listed below.

7.1.1 PIN 0

Optical input 1. Long haul version supports optical level.

```
<identifier> ::= 'pin'
<status> ::= ['cd'|'ncd'] [<rssi>'dBm']
```

7.1.2 TEMP 0

Board temperature.

```
<identifier> ::= 'temp'
<status> ::= ['alarm'] [<temperature>'C'] ['ulim' <temperature>]
           ['llim' <temperature>]
<block command> ::= <upper limit>|<lower limit>
<upper limit> ::= 'ulim' <temperature>
<lower limit> ::= 'llim' <temperature>
```

7.1.3 PWR 0

```
<identifier> ::= 'pwr'
<status> ::= [<nominal voltage>'Vnom'] [<voltage>]
```

7.1.4 PWR 1

```
<identifier> ::= 'pwr'
<status> ::= [<nominal voltage>'Vnom'] [<voltage>]
```

7.1.5 PWR 2

```
<identifier> ::= 'pwr'
<status> ::= [<nominal voltage>'Vnom'] [<voltage>]
```

7.1.6 PWR 3

Only for long haul version.

```
<identifier> ::= 'pwr'
<status> ::= [<nominal voltage>'Vnom'] [<voltage>]
```

7.2 Single converter

FLP4.0 block for single converter is listed below.

7.2.1 RCL 0

Reclocker for output 1.

```

<identifier> ::= 'rcl'
<status> ::= ['en'|'mute'|'bypass'] ['lock'|'lol']
             [<bitrate>'Mbps'] ['asi'|'sdi'|'hdspi']
             ['abp' 'on'|'off'] ['rate' 'man'|'auto']

<block command> ::= <set mode>|<set autobypass>|

<set mode> ::= 'en'|'mute'|'bypass'
<set autobypass> ::= 'abp' 'on'|'off'

```

7.3 Dual converter

FLP4.0 block for dual converter is listed below.

7.3.1 PIN 1

Optical input 1. Long haul version supports optical level.

```

<identifier> ::= 'pin'
<status> ::= ['cd'|'ncd'] [<rssi>'dBm']

```

7.3.2 CHO 0

Input select for output 1.

```

<identifier> ::= 'cho'
<status> ::= [<input>] ['size' 2] [<changeover mode>]
             [<priority list>]

<block command> ::= <set position>|<set priority>

<changeover mode> ::= 'auto'|'man'
<priority list> ::= 'pri' <input>

<set position> ::= 'pos' 'auto'|('man' <input>)
<set priority> ::= 'pri' <input>

```

7.3.3 CHO 1

Input select for output 2.

```

<identifier> ::= 'cho'
<status> ::= [<input>] ['size' 2] [<changeover mode>]
             [<priority list>]

<block command> ::= <set position>|<set priority>

<changeover mode> ::= 'auto'|'man'
<priority list> ::= 'pri' <input>

<set position> ::= 'pos' 'auto'|('man' <input>)
<set priority> ::= 'pri' <input>

```

7.3.4 RCL 0

Reclocker for output 1.

```

<identifier> ::= 'rcl'
<status> ::= ['en'|'mute'|'bypass'] ['lock'|'lol']
             [<bitrate>'Mbps'] ['asi'|'sdi'|'hdspi']
             ['abp' 'on'|'off'] ['rate' 'man'|'auto']

<block command> ::= <set mode>|<set autobypass>|

<set mode> ::= 'en'|'mute'|'bypass'
<set autobypass> ::= 'abp' 'on'|'off'

```

7.3.5 RCL 1

Reclocker for output 2.

```

<identifier> ::= 'rcl'
<status> ::= ['en'|'mute'|'bypass'] ['lock'|'lol']
             [<bitrate>'Mbps'] ['asi'|'sdi'|'hdspi']
             ['abp' 'on'|'off'] ['rate' 'man'|'auto']

<block command> ::= <set mode>|<set autobypass>|

<set mode> ::= 'en'|'mute'|'bypass'
<set autobypass> ::= 'abp' 'on'|'off'

```

General environmental requirements for Nevision equipment

1. The equipment will meet the guaranteed performance specification under the following environmental conditions:
 - Operating room temperature range: 0°C to 40°C
 - Operating relative humidity range: <90% (non-condensing)

2. The equipment will operate without damage under the following environmental conditions:
 - Temperature range: -10°C to 50°C
 - Relative humidity range: <95% (non-condensing)

Product Warranty

The warranty terms and conditions for the product(s) covered by this manual follow the General Sales Conditions by Nevion, which are available on the company web site:

www.nevion.com

Appendix A Materials declaration and recycling information

A.1 Materials declaration

For product sold into China after 1st March 2007, we comply with the “Administrative Measure on the Control of Pollution by Electronic Information Products”. In the first stage of this legislation, content of six hazardous materials has to be declared. The table below shows the required information.

組成名稱 Part Name	Toxic or hazardous substances and elements					
	鉛 Lead (Pb)	汞 Mercury (Hg)	鎘 Cadmium (Cd)	六价铬 Hexavalent Chromium (Cr(VI))	多溴联苯 Polybrominated biphenyls (PBB)	多溴二苯醚 Polybrominated diphenyl ethers (PBDE)
3GHD-OE/ 3GHD-OE-2	○	○	○	○	○	○
<p>O: Indicates that this toxic or hazardous substance contained in all of the homogeneous materials for this part is below the limit requirement in SJ/T11363-2006.</p> <p>X: Indicates that this toxic or hazardous substance contained in at least one of the homogeneous materials used for this part is above the limit requirement in SJ/T11363-2006.</p>						

This is indicated by the product marking:



A.2 Recycling information

Nevion provides assistance to customers and recyclers through our web site <http://www.nevion.com/>. Please contact Nevion’s Customer Support for assistance with recycling if this site does not show the information you require.

Where it is not possible to return the product to Nevion or its agents for recycling, the following general information may be of assistance:

- Before attempting disassembly, ensure the product is completely disconnected from power and signal connections.
- All major parts are marked or labelled to show their material content.
- Depending on the date of manufacture, this product may contain lead in solder.
- Some circuit boards may contain battery-backed memory devices.

EC Declaration of Conformity

MANUFACTURER	Nevion	
AUTHORIZED REPRESENTATIVE (Established within the EEA)	Not applicable	
MODEL NUMBER(S)	3GHD-OE / 3 GHD-OE-2	
DESCRIPTION	Single and dual 3G-SDI optical to electrical converter	
DIRECTIVES this equipment complies with	Low voltage (EU Directive 2006/95/EC) EMC (EU Directive 2004/108/EC) RoHS (EU Directive 2002/95/EC) China RoHS ¹ WEEE (EU Directive 2002/96/EC) REACH	
HARMONISED STANDARDS applied in order to verify compliance with Directive(s)	EN 55103-1:1996 EN 55103-2:1996 EN 60950-1:2006	
TEST REPORTS ISSUED BY	Notified/Competent Body	Report no:
	Nemko	E08463
TECHNICAL CONSTRUCTION FILE NO	Not applicable	
YEAR WHICH THE CE-MARK WAS AFFIXED	2008	
TEST AUTHORIZED SIGNATORY		
MANUFACTURER	AUTHORIZED REPRESENTATIVE (Established within EEA)	Date of Issue
		2010-03-09
		Place of Issue
	Not applicable	Sandefjord, Norway
Name	Thomas Øhrbom	
Position	VP of Business Support Systems, Nevion (authorized signature)	

¹ Administration on the Control of Pollution Caused by Electronic Information Products

