



MMusb2232

User's Manual

REV 1.0

Introduction

MMusb2232 is low-cost integrated module for data transmission via USB 2.0 Full Speed interface with maximum transfer 12 Mbit/s. It is based on FTDI's FT2232C device. Module features two Multi-Purpose UART/FIFO controllers that can be configured individually in several modes. In addition to the UART interface, FIFO interface, and Bit-Bang I/O modes of the second-generation FT232BM and FT245BM devices, the FT2232C offers a variety of additional modes of operation including a Multi-Protocol Synchronous Serial Engine interface designed specifically for synchronous serial protocols such as JTAG and SPI bus.

MMusb2232 is made in two-layer printed circuit board technology with a solid ground plane. Module includes an integral 93C56 EEPROM on board which is programmable via USB. All signals are drive via 34 pin, 1.1 in wide footprint. Integral power control makes the MMusb2232 a perfect choice for USB bus-powered, high power designs as well as self- and low-powered products.

Choosing our Minimodule is the first step for projects, which should be done in the short time. MMusb2232 could be used both prototype eliminating necessity of designing circuit board and final circuit in which module is fitted like "sandwich shape".

We wish you were successful at designing and using new devices

Features Summary

- Single board, USB Dual Channel Serial / Parallel Ports with a variety of configurations
- Entire USB protocol handled on-board. No USB-specific firmware programming required
- UART interface option with full Handshaking & Modem interface signals
- UART Interface supports 7/8 bit data, 1/2 stop bits, and Odd/Even/Mark/Space/NoParity
- Transfer Data Rate 300 to 1 Mega Baud (RS232)
- Transfer Data Rate 300 to 3 Mega Baud (TTL and RS422 / RS485)
- Auto Transmit Enable control for RS485 serial applications using TXDEN pin
- MMusb245-style FIFO interface option with bi-directional data bus and simple 4-wire handshake interface
- Transfer Data Rate up to 1 MegaByte / Second
- Enhanced Bit-Bang Mode interface option
- New Synchronous Bit-Bang Mode interface option
- New CPU-Style FIFO Interface Mode option
- New Multi-Protocol Synchronous Serial Engine (MPSSE) interface option
- New MCU Host Bus Emulation Mode option
- New Fast Opto-Isolated Serial Interface Mode option
- Interface mode and USB Description strings configurable in on-board EEPROM
- EEPROM Configurable in-circuit via USB
- Support for USB Suspend and Resume conditions via PWREN#, and SI/WUx pins
- Support for bus powered, self powered, and high-power bus powered USB configurations
- Integrated Power-On-Reset circuit, with optional Reset input and Reset Output pins
- 5V and 3.3V logic IO Interfacing with independent level conversion on each channel
- USB Bulk or Isochronous data transfer modes
- 4.35V to 5.25V single supply operating voltage range
- UHCI / OHCI / EHCI host controller compatible

- USB 2.0 Full Speed (12 Mbits / Second) compatible
- 4 diodes LED which signalize transmission on lines TXD and RXD channel's A and B
- Standard 34-pin, 0.6in wide footprint

Virtual Com Port (VCP) drivers

- Windows 98 / 98 SE / 2000 / ME / XP

D2XX (Direct Drivers + DLL S/W)

- Windows 98 / 98 SE / 2000 / ME / XP

Application areas

- USB Dual Port RS2232 Converters
- USB Dual Port RS422 / RS485
- Upgrading Legacy Peripheral Designs
- USB Instrumentation
- USB JTAG Programming
- USB to SPI Bus Interfaces
- USB Industrial Control
- Field Upgradeable USB Products
- Galvanically Isolated Products with USB Interfaces
- Toys

General Description

The **MMusb2232** module is a USB interface that incorporates the functionality of two chips FT232BM and FT245BM into a single 34-pin module. A single downstream USB port is converted to two IO channels that can each be individually configured as UART interface, or FIFO interface, without the need to add a USB hub.

There are also several new modes which can be enabled in the external EEPROM, or by using DLL driver commands. These include Synchronous Bit-Bang Mode, a CPU-Style FIFO Interface Mode, a Multi-Protocol Synchronous Serial Engine Interface Mode, MCU Host Bus Emulation Mode, and Fast Opto-Isolated Serial Interface Mode. Additionally, a new high output drive level option means that the device UART / FIFO IO pins will drive out at around three times the normal power level, allowing the data bus to be shared by several devices.

Classic BM-style Asynchronous Bit-Bang Mode is also supported, but has been enhanced to give the user access to the device's internal RD# and WR# strobes.

FTDI provides a royalty free Virtual Com Port (VCP) driver that makes the peripheral ports look like a standard COM port to the PC. Most existing software applications should be able to interface with the Virtual Com Port simply by reconfiguring them to use the new ports created by the driver. Using the VCP drivers, an application programmer would communicate with the device in exactly the same way as they would a regular PC COM port - using the Windows VCOMM API calls or a COM port library. The FT2232C driver also incorporates the functions defined for FTDI's D2XX drivers, allowing applications programmers to interface software directly to the device using a Windows DLL.

MMusb2232 Module Simplified Block Diagram

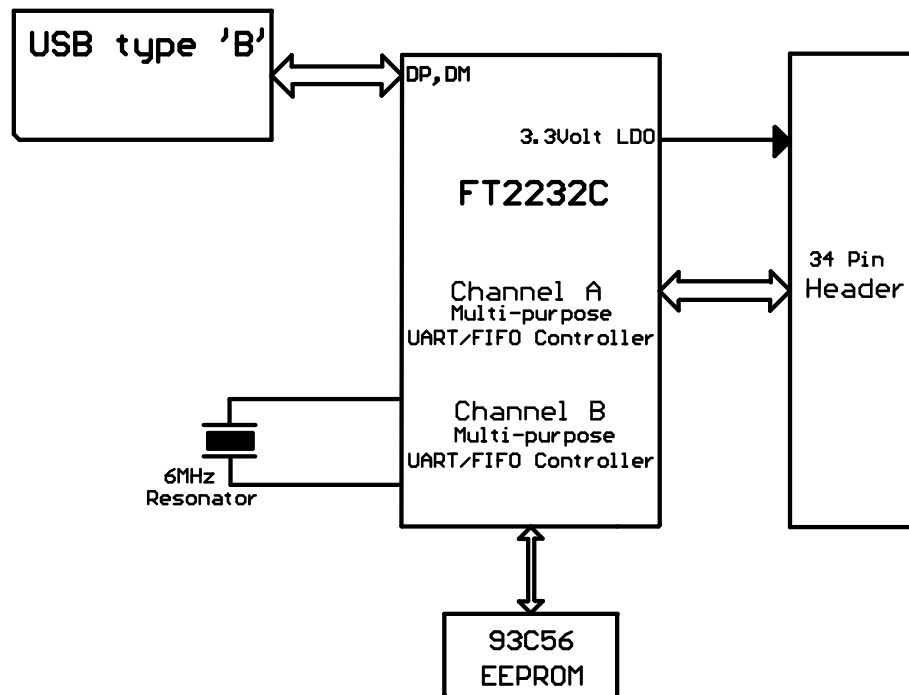

Figure 1. MMusb2232 block diagram.

Functional Block Descriptions

6MHz Oscillator

The 6MHz Oscillator cell generates a 6MHz reference clock input to the x8 Clock multiplier from an external 6MHz ceramic resonator.

Multi-Purpose UART / FIFO Controllers

The Multi-purpose UART / FIFO controllers handle the transfer of data between the Dual Port RX and TX buffers and the UART / FIFO transmit and receive registers. When configured as a UART it performs asynchronous 7/8 bit parallel to serial and serial to parallel conversion of the data on the RS232 (RS422 and RS485) interface. Control signals supported by UART mode include RTS, CTS, DSR, DTR, DCD and RI. There are also transmitter enable control signal pins (TXDEN) provided to assist with interfacing to RS485 transceivers. RTS/CTS, DSR/DTR and X-On/X-Off handshaking options are also supported. Handshaking, where required, is handled in hardware to ensure fast response times. The UARTs also support the RS232 BREAK setting and detection conditions.

EEPROM Interface

The on-board 93C56 EEPROM allows each of the MMusb2232 module's channels to be independently configured as a serial UART (232 mode), or a parallel FIFO (245 mode). The EEPROM is used to enable the CPU-style FIFO interface, and Fast Opto-Isolated Serial interface modes. The EEPROM can also be used to customize the USB VID, PID, Serial Number, Product Description Strings and Power Descriptor value of the MMusb2232 for OEM applications. Other parameters controlled by the EEPROM include Remote Wake Up, Isochronous Transfer Mode, Soft Pull-Down on Power-Off and USB 2.0 descriptor modes. The EEPROM is programmable in-circuit via USB using a utility program available from both FTDI's web site (www.ftdichip.com) and www.propox.com.

Module Pin-Out

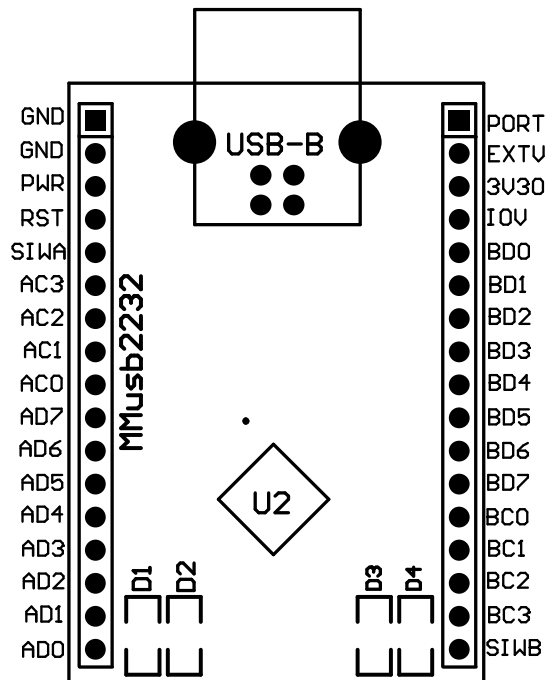

Figure 2. Pin-Out

Pin Definitions

This section describes the operation of the MMusb2232 pins. Common pins are defined in the first section and the I/O pins are defined by chip mode.

Common Pins

The operations of the following MMusb2232 pins stay the same, regardless of the operating mode.

Pin#	Signal /on module	Type	Description
31	RESET /RST	Input	Can be used by an external device to reset the FT2232C. If not required, can be left disconnected.
2	EXTVCC /EXTV	Input	+4.35 to +5.25 volt VCC to the device core, LDO and non-UART / FIFO controller interface pins. Device Analog Power Supply for the internal x8 clock multiplier.
4	IOVCC /IOV	PWR	+3.0 to +5.25 volt VCC to the UART/FIFO Channel A interface pins. When interfacing with 3.3V external logic connect VCCIO to the 3.3V supply of the external logic, otherwise connect to VCC to drive out at 5V CMOS level.
1	PORTVCC /PORT	PWR	Power from USB port. Connect to EXTVCC if module is to be powered by the USB port (typical configuration). 500mA maximum current available to USB adapter and target electronics if USB device is configured for high power.
3	3V3OUT /3V30	PWR	Output signal 3.3V

IO Pin Definitions by Chip Mode .

Pin Definitions by Chip Mode (2)

Pin#	Pin Name /on module	232 UART Mode	245 FIFO Mode	CPU FIFO Interface Mode	Enhanced Asynchronous and Synchronous Bit-Bang Modes	MPSSE (4)	MCU Host Bus Enumeration Mode (5)	Fast Opto-Isolated Serial Mode
18	ADBUS0/AD0	TXD	D0	D0	D0	TCK/SK	AD0	(3)

Commentary:

(2) - 232 UART, 245 FIFO, CPU FIFO Interface, and Fast Opto-Isolated modes are enabled in the external EEPROM. Enhanced Asynchronous and Synchronous Bit-Bang modes, MPSSE, and MCU Host Bus Emulation modes are enabled using driver commands.

(3) - Channel A can be configured in another IO mode if channel B is in Fast Opto-Isolated Serial Mode. If both Channel A and Channel B are in Fast Opto-Isolated Serial Mode all of the IO will be on Channel B.

(4) - MPSSE is Channel A only.

(5) - MCU Host Bus Emulation requires both Channels.

(6) - The Bit-Bang Mode (synchronous and asynchronous) WR# and RD# strobes are on these pins when the main Channel mode is 245 FIFO, CPU FIFO interface, or Fast Opto-Isolated Serial Modes.

(7) - The Bit-Bang Mode (synchronous and asynchronous) WR# and RD# strobes are on these pins when the main Channel mode is 232 UART Mode.

(8) - The Bit-Bang Mode (synchronous and asynchronous) WR# and RD# strobes are on these pins when the main Channel mode is 245 FIFO, CPU FIFO interface. Bit-Bang mode is not available on Channel B when Fast Opto-Isolated Serial Mode is enabled.

Technical Parameters

Dimensions	: 46,16 x 31,8 x 19,63 mm
Weight	: about 70 g
Power supply	: 5V
Power dissipation	: 500mW

Mechanical Dimensions

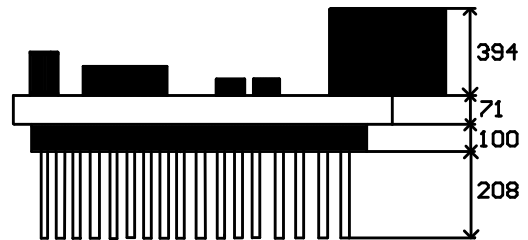
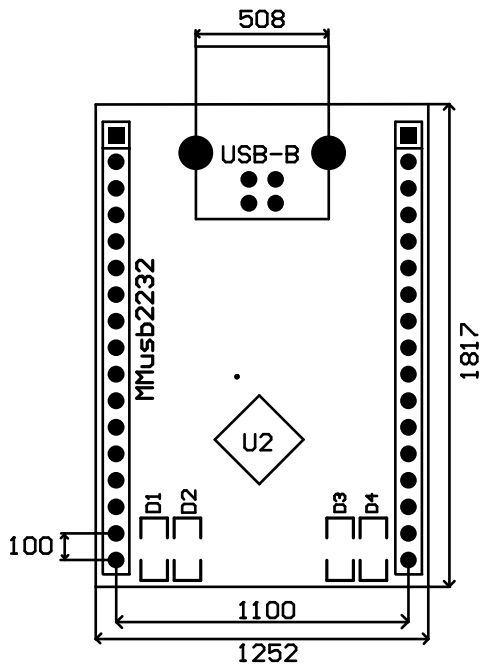

Dimensions are in miles.
1miles – 1/1000 inch
100miles = 2,54mm

Standard Device Configuration Examples

USB Bus Powered and Self Powered Configuration

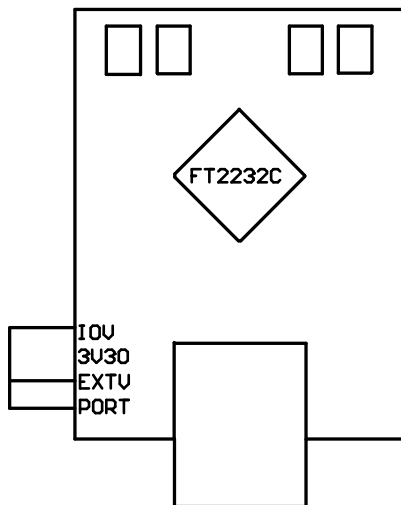

Figure 3a.USB Bus Powered Configuration

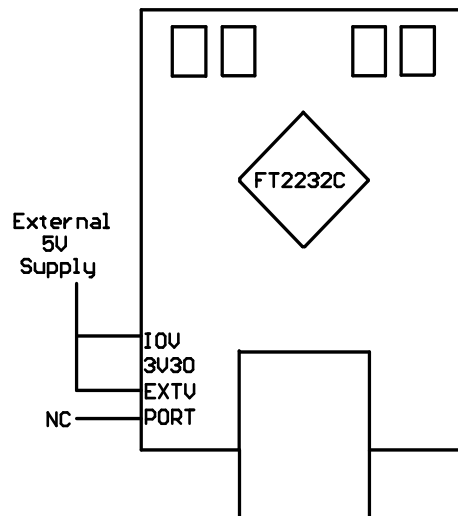

Figure 3b.Self Powered Configuration

Figure 3a illustrates the MMusb2232 in a typical USB bus powered configuration. A USB Bus Powered device gets its power from the USB bus. Basic rules for USB Bus power devices are as follows:

- On plug-in, the device must draw no more than 100mA
- On USB Suspend the device must draw no more than 500uA.
- A High Power USB Bus Powered Device (one that draws more than 100mA) should use the on-board MOSFET to keep the current drawn by external circuitry to below ~70mA on plug-in and ~200uA on USB suspend.
- A device that consumes more than 100mA cannot be plugged into a USB Bus Powered Hub
- No device can draw more that 500mA from the USB Bus. The power descriptor in the EEPROM should be programmed to match the current draw required by the device. A Ferrite Bead is connected in series with USB power to prevent noise from the device and associated circuitry (EMI) being radiated down the USB cable to the host.

Figure 3b illustrates the MMusb2232 in a typical USB self powered configuration. A USB Self Powered device gets its power from its own power supply and does not draw current from the USB bus. The basic rules for USB Self power devices are as follows –

- A Self-Powered device should not force current down the USB bus when the USB Host or Hub Controller is powered down.
- A Self-Powered device can take as much current as it likes during normal operation and USB suspend as it has its own power source.
- A Self-Powered device can be used with any USB Host and both Bus and Self Powered USB Hubs.

The USB power descriptor option in the EEPROM should be programmed to a value of zero (self powered).

To meet requirement a) the 1.5K pull-up resistor on USBDP is connected to RSTOUT# as per the bus-power circuit. However, the USB Bus Power is used to control the RESET# Pin of the FT2232C device. When the USB Host or Hub is powered up RSTOUT# will pull the 1.5K resistor on USBDP to 3.3V, thus identifying the device as a full speed device to USB. When the USB Host

or Hub power is off, RESET# will go low and the device will be held in reset. As RESET# is low, RSTOUT# will also be low, so no current will be forced down USBDP via the 1.5K pull-up resistor when the host or hub is powered down. Failure to do this may cause some USB host or hub controllers to power up erratically.

Note: When the MMusb2232 is in reset, the I/O interface pins all go tri-state. These pins have 200K pull-up resistors to VCCIOx internal to the FT2232C, so they will gently pull high unless driven by some external logic.

Interfacing to Microcontrollers

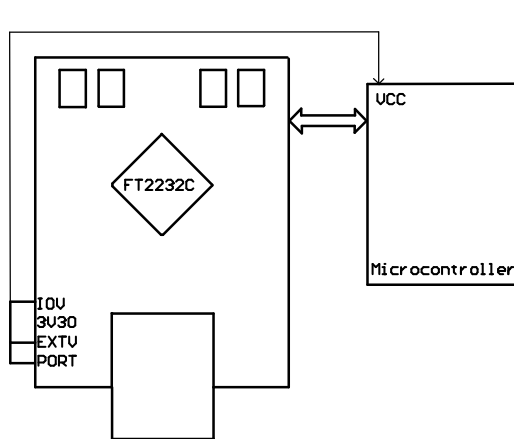

Figure 4a

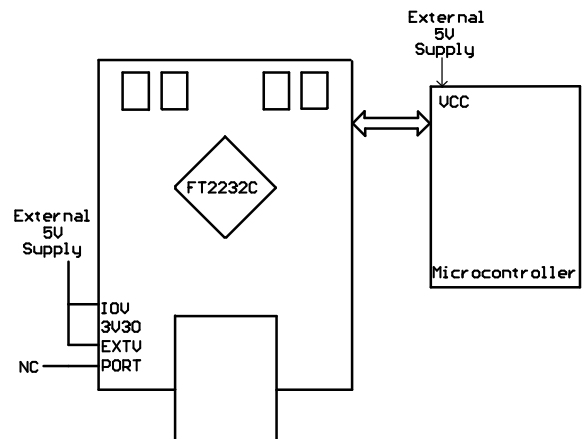

Figure 4b

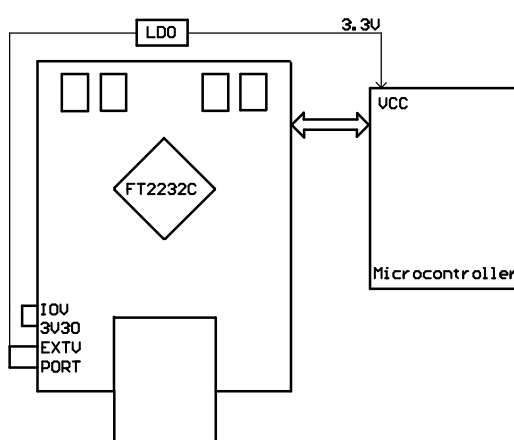

Figure 4c

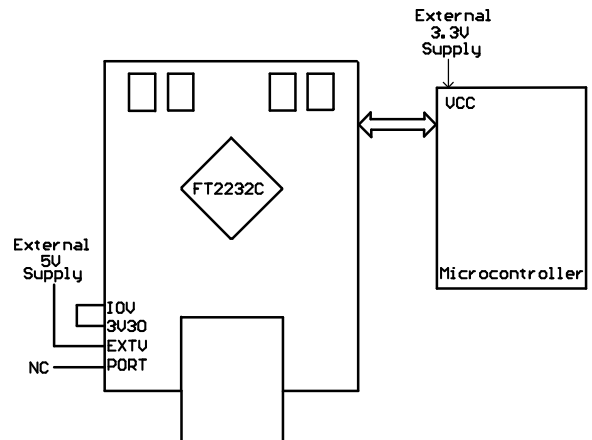

Figure 4d

USB Bus-Powered, 5V Systems

Figure 4a shows how to configure the MMusb2232 to interface with a 5V microcontroller. In this example, the USB port is the power source for VCCIOA and VCCIOB, which in turn will cause the device interface IO pins on both channels to drive out at the 5V level. In this configuration, must be on-board MOSFET power switch controls power to the microcontroller. Care must be taken to ensure all microcontroller circuitry, when combined with the MMusb2232M circuitry, does not exceed the maximum available current from the USB port of 500mA for a high-powered USB device.

USB Self-Powered, 5V Systems

Figure 4b is an example of a MMusb2232 USB self-powered design with 5V interface. In this case, the VCCIOA and VCCIOB pins are supplied by an external 5V supply in order to make both of the device's IO channels drive out at 5V logic level, thus allowing them to be connected to a 5V microcontroller or other external logic. A USB self-powered design uses its own power supplies, and does not draw any of its power from the USB bus. In such cases, no special care need be taken to meet the USB suspend current (0.5 mA) as the device does not get it's power from the USB port. Note that if the SI/WUx pins are not being used they should be pulled up to the same supply as their respective VCCIOx pin.

USB Bus-Powered, 3.3V Systems

Figure 4c shows how to configure the MMusb2232 to interface with a 3.3V microcontroller. In this example, a discrete 3.3V regulator is used to supply the 3.3V logic from the USB supply. VCCIOA and VCCIOB are connected to the output of the 3.3V regulator, which in turn will cause the device interface IO pins on both channels to drive out at 3.3V level. It is also possible to have one IO interface channel driving out at 5V level, and the other at 3.3V level. In this case one of the VCCIOx pins would be connected to 5V, and the other connected to 3.3V. For USB bus powered circuits, care must be taken when selecting the regulator. The regulator must be capable of sustaining its output voltage with an input voltage of 4.35 volts. A Low Drop Out (LDO) regulator must be selected. An example of a regulator family that meets these requirements is the MicroChip (Telcom) TC55 Series. These devices can supply up to 250mA current.

Note: It should be emphasized that the 3.3V supply, for VCCIOx in a bus powered design with a 3.3V logic interface, should come from an LDO that is supplied by the USB bus, not from any other source. Please also note that if the SI/WUx pins are not being used they should be pulled up to the same supply as their respective VCCIOx pin.

USB Self-Powered, 3.3V Systems

Figure 4d is an example of a MMusb2232 USB self-powered design with 3.3V interface. In this case, the VCCIOA and VCCIOB pins are supplied by an external 3.3V supply in order to make both of the device's IO channels drive out at 3.3V logic level, thus allowing them to be connected to a 3.3V microcontroller or other external logic. It is also possible to have one IO interface channel driving out at 5V level, and the other at 3.3V level. In this case one of the VCCIOx pins would be connected to 5V, and the other connected to 3.3V.

A USB self-powered design uses its own power supplies, and does not draw any of its power from the USB bus. In such cases, no special care need be taken to meet the USB suspend current (0.5 mA) as the device does not get it's power from the USB port. Note that if the SI/WUx pins are not being used they should be pulled up to the same supply as their respective VCCIOx pin.

Technical Support

If You have problem with MMusb2232, please contact us at support@propox.com.

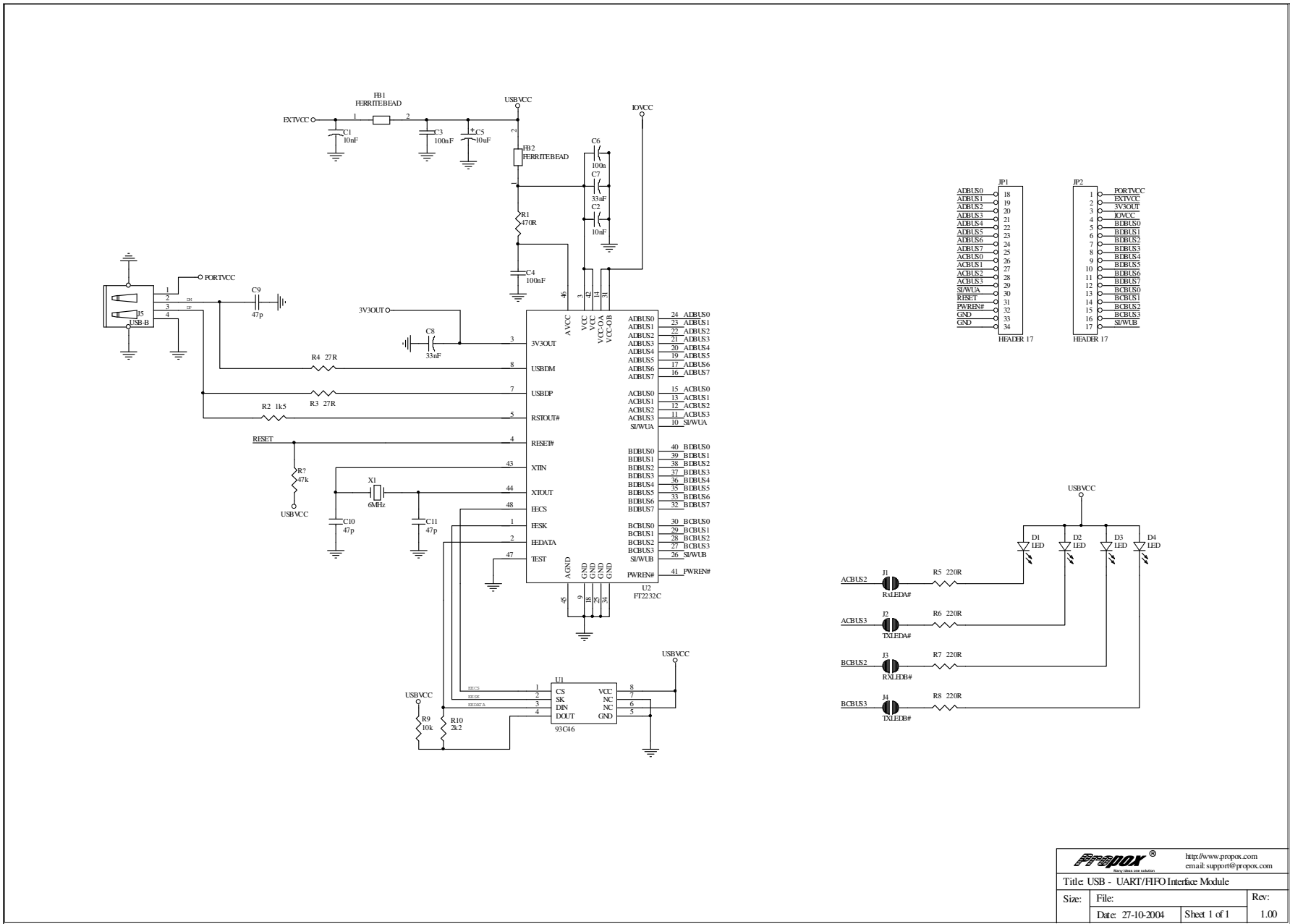

PREPOX <small>Many ideas one solution</small>		http://www.prepo.com email: support@prepo.com	
Title: USB - UART/HFIO Interface Module			
Size:	File:	Date:	Rev:
		27-10-2004	1.00
		Sheet 1 of 1	