

Model

1190



Data

Collection

Platform

User's

Manual

Copyright © 2010, All Weather, Inc.

All Rights Reserved. The information contained herein is proprietary and is provided solely for the purpose of allowing customers to operate and/or service All Weather, Inc. manufactured equipment and is not to be released, reproduced, or used for any other purpose without written permission of All Weather, Inc.

Throughout this manual, trademarked names might be used. Rather than put a trademark (™) symbol in every occurrence of a trademarked name, we state herein that we are using the names only in an editorial fashion and to the benefit of the trademark owner, and with no intention of infringement. All Weather, Inc. and the All Weather, Inc. logo are trademarks of All Weather, Inc.

Disclaimer

The information and specifications described in this manual are subject to change without notice.

Latest Manual Version

For the latest version of this manual, see the *Product Manuals* page under *Reference* on our web site at www.allweatherinc.com/.



**All Weather, Inc.
1165 National Drive
Sacramento, CA 95834
Tel.: (916) 928-1000
Fax: (916) 928-1165**

Contact Customer Service

- **Phone** support is available from 8:00am - 4:30pm PST, Monday through Friday. Call 916-928-1000 and ask for “Service.”
- **Online** support is available by filling out a request at www.allweatherinc.com/customer/support.html
- **E-mail** your support request to support@allweatherinc.com

TABLE OF CONTENTS

1.	INTRODUCTION	1
2.	INSTALLATION	3
	DCP Installation.....	3
	Sensor Wiring	3
	Communication Connections.....	4
	Serial Sensor Wiring.....	5
	Power Wiring.....	5
3.	OPERATION.....	7
	General.....	7
	Maintenance Switch.....	7
	DIP Switches.....	7
	Display Screens.....	8
	LED Indicators.....	16
4.	CALIBRATION	17
5.	MAINTENANCE.....	19
6.	WARRANTY	21
7.	SPECIFICATIONS.....	23
8.	DRAWINGS.....	25

1. INTRODUCTION

The Model 1190 Data Collection Platform (DCP) is used with Automated Weather Observing Systems (AWOS) for collecting and processing sensor signals. Located at the sensor station, the DCP collects data from the sensors, performs error detection on the received information, converts the sensors' data into engineering units, and transmits a message packet containing sensor data and status information to the Central Data Platform (CDP) once every five seconds.

2. INSTALLATION

DCP Installation

The Model 1190 DCP mounts to the sensor tower using Unistrut; optional barometric pressure (Model 7190) and radio kits mount inside the DCP enclosure. Installation drawings in the *Drawings* chapter of this manual illustrate the installation procedures. Refer to those drawings when installing the DCP (1190-007), the 7190 barometric pressure sensor (M403316-003), and the 20980-A radio (M403316-003).

Two or three junction boxes—1) AC power, 2) ceilometer and visibility signal, and 3) landline (present only when a radio data link is not used)—that were installed during the site preparation procedure are located at the edge of the tower foundation. After installing the DCP on the tower, install flexible or rigid conduit between the junction boxes and the holes in the underside of the DCP enclosure. Route the wires from the junction boxes through the conduit into the DCP.

Wiring diagrams 903-A-019, 903-B-019, 903-C-019, 903-D-019, 903-E-019, 903-G-019, 903-H-019, and 903-HH-019 in the *Drawings* chapter of this manual illustrate the wiring connections described below.

Sensor Wiring

The AWOS sensors are connected to the DCP at a series of terminal blocks along the left side of the backplane.

TB2

- The MARS (Motor Aspirated Radiation Shield), Wind Speed sensor, and Temperature/Relative Humidity sensor connect to TB2.

TB3

- The Day/Night sensor, Rain Gauge, Auxiliary sensor, and Wind Direction sensor connect to TB3.

TB4

- The Ceilometer, Visibility Sensor, and Present Weather Sensor interface to interconnecting daughter boards that mount to the backplane. They communicate via an RS-485 bus accessed at TB4. The Thunderstorm/Lightning Sensor's signal lines connect directly to TB4.

TB2—MARS Wiring

Power for a Model 8190 MARS unit is obtained at pins 9 and 10 of TB2.

- 1 Connect the WHITE positive lead of the MARS power cable to pin 9.
- 2 Connect the BLACK negative lead of the MARS power cable to pin 10.

TB2—Wind Speed Wiring

Either a Model 2030 Micro Response Anemometer or a Model 2100 Skyvane can be used to sense wind speed. The wind speed sensor is wired to pins 5–8 of TB2.

2030 Wiring

When wiring a Model 2030 Micro Response Anemometer to the DCP, connect as follows:

- 1 Connect the BLACK wire to pin 5 of TB2.
- 2 Connect the WHITE wire to pin 6 of TB2.
- 3 Connect the GREEN wire to pin 7 of TB2.
- 4 Connect the RED wire to pin 8 of TB2.

2100 Wind Speed Wiring

When wiring a Model 2100 Skyvane to the DCP, connect the wind speed portion as follows:

- 1 Connect the RED wire to pin 5 of TB2.
- 2 Connect the WHITE wire to pin 6 of TB2.
- 3 Connect the GREEN wire to pin 7 of TB2.
- 4 Connect the BLACK wire to pin 8 of TB2.

TB2—Temperature/Relative Humidity Wiring

The Model 5190 Temperature/Relative Humidity sensor is wired to pins 1-4 of TB2 as follows (refer to the sensor manual for corresponding wire colors):

- 1 Connect the BROWN temperature signal wire (TEMP) to pin 1 of TB2.
- 2 Connect the WHITE relative humidity signal wire (RH) to pin 2 of TB2.
- 3 Connect the GREEN positive power lead (V+) to pin 3 of TB2.
5190-D
- 4 Connect the GRAY, BLUE and SHIELD wires to pin 4 of TB2.
5190-F
- 4 Connect the GRAY, YELLOW and SHIELD wires to pin 4 of TB2.

TB3—Day/Night Sensor Wiring

The Model 83339-A Day/Night sensor's two wires connect to pins 9 and 10 of TB3.

- 1 Connect the positive lead to pin 9.
- 2 Connect the negative lead to pin 10.

Note: For 8364-E Visibility Sensor installations, the visibility sensor provides the Day/Night sensor output, and the Model 83339-A is not installed.

TB3—Rain Gauge Wiring

The Model 6011 or 6021 Rain Gauge connects to pins 7 and 8 of TB3. These two pins are interchangeable, allowing the two rain gauge wires to be connected to either pin.

TB3—Auxiliary Sensor Wiring

An auxiliary voltage output sensor (such as a solar radiation sensor) can be connected to the DCP via pins 5 and 6 of TB3.

- 1 Connect the positive lead from the auxiliary sensor to pin 5 of TB3.
- 2 Connect the negative lead from the auxiliary sensor to pin 6 of TB3.

TB3—Wind Direction Wiring

The wind direction sensor is wired to pins 1–3 of TB3. Either a Model 2020 Micro Response Vane or a Model 2100 Skyvane can be used.

2020 Wiring

When wiring a Model 2020 Micro Response Vane to the DCP, connect as follows:

- 1 Connect the WHITE wire to pin 1 of TB3.
- 2 Connect the RED wire to pin 2 of TB3.
- 3 Connect the BLACK wire to pin 3 of TB3.

2100 Wind Direction Wiring

When wiring a Model 2100 Skyvane to the DCP, connect the wind direction portion as follows:

- 1 Connect the ORANGE wire to pin 1 of TB3.
- 2 Connect the GREEN wire to pin 2 of TB3.
- 3 Connect the BLUE wire to pin 3 of TB3.

TB3—+5 V Power

A +5 V output is available at pin 4 of TB3. This is used as a test point by the Model 11920 Sensor Simulator to verify the DCP's +5 V power supply.

Communication Connections

The DCP can communicate with the CDP (Central Data Platform) using one of three available methods: RS-232, RS-485, or UHF Radio. Only one of these methods can be in use at any one time, with the active method determined by the settings of switch SW1. (Refer to the **DIP Switches** section of the *Operation* chapter of this manual for the required switch settings.) Connections for RS-232 and RS-485 communication are found at TB4.

TB4—RS-232 Wiring

Since the distance separating the DCP and CDP is generally too great for RS-232 communications, it is an impractical method for this use. The RS-232 port provided at pins 5-7 of TB4 is intended as a maintenance port, allowing DCP operation to be checked using a laptop computer. The three pins have the following functions:

- 1 Pin 5 is data transmit (TX), and should be connected to the laptop's data receive (RX) line.

- 2 Pin 6 is data receive (RX), and should be connected to the laptop's data transmit (TX) line.
- 3 Pin 7 is ground (GND).

Note: Remember that only one communication method can be in effect at any one time, determined by SW1's switch settings. If communication with the CDP is being maintained using RS-485 or UHF radio, when the RS-232 port is activated other communication will cease.

TB4—5 V Power

A -5 V output is available at pin 8 of TB4. This is used as a test point by the Model 11920 Sensor Simulator to verify the DCP's -5 V power supply.

TB4—RS-485 Wiring

When RS-485 communication is used to communicate with the CDP, pins 9 and 10 of TB4 are used to make the connection.

- 1 Connect the positive lead of the RS-485 line from the CDP to pin 9 of TB4.
- 2 Connect the negative lead of the RS-485 line from the CDP to pin 10 of TB4.
- 3 Connect the ground lead of the RS-485 line from the CDP to pin 7 of TB4.

TB4—RS-485 Expansion Port

The two RS-485 connections on TB4 (1-2 and 3-4) are used to connect RS-485 sensors such as the 6490 Present Weather Sensor, 8364-E Visibility Sensor, and 6500 Thunderstorm/Lightning Sensor.

Model 6490 Present Weather Sensor

- 1 Connect the Model 6490's signal cable to pins 1 and 2 of terminal block TB4.
- 2 Connect the ground wire to pin 7 of terminal block TB4.

Model 8364-E Visibility Sensor

- 1 Connect the Model 8364-E's signal cable to pins 2 and 3 of terminal block TB4.
- 2 Connect the ground wire to pin 7 of terminal block TB4.

Model 6500 Thunderstorm/Lightning Sensor

- 1 Connect the Model 6500's signal cable to pins 1 and 2 of terminal block TB4.
- 2 Connect the ground wire to pin 7 of terminal block TB4.

Serial Sensor Wiring

When using a 2040/2040H/2040HH Ultrasonic Wind Sensor, 8329 Ceilometer, 8339 Ceilometer, 6495 Freezing Rain Sensor, or 8364-C Visibility Sensor, a separate "daughter board" is added to the backplane to interface to the sensor. The daughter boards are connected to one another via an internal RS-485 bus. Connect the sensors' signal cables to their appropriate daughter boards at TB1 pins 1-3 on the daughter board.

Power Wiring

AC Power Wiring

(See drawing M404802-004 in the *Drawings* chapter.) AC line power is input to the DCP via the AC Interface Board (M404802). Connect incoming AC power to TB1 on the AC Interface Board (**not** TB1 on the DCP backplane) as follows:

- 1 Connect the AC LINE (hot) wire to TB1, pin 1.
- 2 Connect the AC NEUTRAL wire to TB1, pin 2.
- 3 Connect the AC GROUND wire to TB1, pin 3.

DC, Battery Backup, and Solar Power Wiring

TB1 on the DCP backplane provides input power connections for a +15VDC supply (provided by the AC Interface Board), backup battery power, and solar power.

+15 V DC Power

The DCP is usually powered by the AC Interface Board, which provides a +15VDC output. This +15 V is input to the DCP at pins 5 (+) and 6 (-) of TB1.

- 1 Connect the positive lead from the AC Interface Board to pin 5 of TB1.
- 2 Connect the negative lead from the AC Interface Board to pin 6 of TB1.

Battery Power

The DCP is equipped with a battery charging circuit that allows it to be powered by a rechargeable 12 V backup battery during short power outages. The battery connects to pins 1 (+) and 2 (-) of TB1.

- 1 Connect the battery's positive lead to pin 1 of TB1.
- 2 Connect the battery's negative lead to pin 2 of TB1.

The battery charging circuit supplies current to the battery at different levels and voltages depending on the state of the battery. If the battery is low, the circuit senses this and provides a trickle charge, and continues to charge the battery to full capacity. The state of the battery and the progress of the charging process are monitored by two LEDs on the DCP backplane.

The green **BATT. CHARGE** LED indicates, when lighted, that the battery is charged to operating levels.

The red LED labeled **FLOAT CHARGE** indicates, when lighted, that the battery is in the final stages of its charging cycle. When the battery is being charged after being largely depleted, both the **FLOAT CHARGE** and **BATT. CHARGE** lights will be off until the charging cycle is nearly complete.

When a battery is not connected, the **FLOAT CHARGE** LED is always on.

Solar Power

Where conditions permit, the DCP can be powered by a solar power kit rather than by the AC Interface Board. (Consult All Weather, Inc. for solar power requirements for a given site.) The solar power unit connects to TB1 at pins 3 (+) and 4 (-).

- 1 Connect the positive lead from the solar power unit to pin 3 of TB1.
- 2 Connect the negative lead from the solar power unit to pin 4 of TB1.

3. OPERATION

General

The Model 1190 Data Collection Platform (DCP) is designed for use with the All Weather, Inc. AWOS aviation weather systems. The DCP collects data from the AWOS sensors, performs error detection on the received information, converts the sensors' data into engineering units, and transmits a message packet containing sensor data and status information to the Central Data Platform (CDP) once every five seconds. The DCP interfaces to the following sensors:

- Model 2100 or Model 2030 Wind Speed Sensor
- Model 2100 or Model 2020 Wind Direction Sensor
- Model 2040/2040H/2040HH Ultrasonic Wind Sensor
- Model 5190 Temperature and Relative Humidity Sensor
- Model 8190 Motor Aspirated Radiation Shield (MARS)
- Model 7190 Barometric Pressure Sensor
- Model 6011-A/B or 6021-A/B Rain Gauge
- Model 83339-A Day/Night Sensor
- M403326 Day/Night Sensor
- Model 8360, 8362-A/B, 8364-A/B/C/D/E Visibility Sensors
- Model 8329-A/B Cloud Height Sensor
- Model 8339-D/F Ceilometer
- Model 6490 (OWI-120) Present Weather Sensor
- Model 6500 Thunderstorm/Lightning Sensor
- Model 6495 Freezing Rain Sensor
- One auxiliary voltage input Sensor (0–10 V DC)

Maintenance Switch

A maintenance switch (SW3) is located on the DCP backplane, on the lower right side of the board. This momentary switch should be pressed any time maintenance is performed on any part of the AWOS system, prior to beginning maintenance. The switch closure will be recorded by the CDP, thereby alerting airport personnel that sensor data may be invalid (due to calibration or maintenance checks being performed), and keeping an ongoing log of maintenance activity at the site. The ON state of the switch (shown both on the DCP's LCD display and at the CDP) will be reset to OFF automatically after five minutes. This switch must be pressed to enable several maintenance functions from the keypad.

DIP Switches

(Note: DIP switches SW1 and SW2 are set at the factory according to each system's specific configuration.)

Two DIP switch assemblies (SW1 and SW2) on the DCP backplane are used to set configuration parameters for the DCP. These switches are set at the factory and should not need to be changed.

The first set of switches, SW1, specifies the communication method in use between the DCP and CDP (RS-232, RS-485, or UHF Radio). **Table 1** shows the switch settings for each communication setup.

Comm. Input/Output	Switches							
	1	2	3	4	5	6	7	8
RS-232	ON	OFF	OFF	ON	OFF	OFF	OFF	OFF
RS-485	OFF	ON	OFF	OFF	ON	OFF	ON	ON
UHF Radio	OFF	OFF	ON	OFF	OFF	ON	OFF	OFF

Model 1190 Data Collection Platform

The second set of switches, SW2, is used to set the station address, type of wind speed sensor, and the auxiliary input gain.

- The station address should normally be set to 0, unless multiple DCPs are used.
- The wind speed sensor setting should agree with the model sensor used (2100, 2040, or 2030).
- The auxiliary input gain can be set to 1, 10, or 50, depending on the type of sensor (if any) connected to the auxiliary input.

The setting combinations for switch SW2 are shown in **Table 2**.

Selection	Switches							
	1	2	3	4	5	6	7	8
Station 0	OFF	OFF						
Station 1	ON	OFF						
Station 2	OFF	ON						
Station 3	ON	ON						
2100 Wind Speed			OFF	OFF	ON			
2030 Wind Speed			OFF	ON	OFF			
2040/2040-H			ON	OFF	OFF			
Aux. Gain 1						ON	OFF	OFF
Aux. Gain 10						OFF	ON	OFF
Aux. Gain 50						OFF	OFF	ON

Display Screens

Located inside the DCP enclosure are a keypad and LCD display screen, which are used for viewing sensor data and performing maintenance checks. The screens available at the DCP are explained in the following sections. The * and # keys on the keypad are used for moving through the screens. To move down (to a higher numbered screen), press the # key. To move up (to a lower numbered screen), press the * key.

In the screen explanations below, unchanging screen text is shown unbracketed, while explanations of the data values for specific parameters are shown in brackets.

Screen 1

This screen displays the value of the DCP address dip switch SW1 and the status of the maintenance switch. The maintenance switch will retain its ON value for 5 minutes after being pressed.

Address Switch = {dcp poll address}

Maint Switch {On / Off}

Screen 2

This screen identifies the type of wind speed sensor as configured by SW2.

Wind Speed Sensor

{2030 Micro Response, 2100 Skyvane, or 2040 Ultrasonic}

Screen 3

This screen displays the current wind speed in knots, and wind direction values. If the Model 2040 Ultrasonic sensor is used and an error is detected, the error will be displayed in place of wind data.

Wind Speed {speed in knots to the nearest .1 knot}

Wind Dir {direction} True; or Wind Dir 999 if missin

Screen 4

This screen displays the current temperature and dew point temperature in Celsius and the relative humidity (RH).

Temp {temperature in degrees Celsius to nearest .1 degree C} RH {rh value}

Dew Point {dew point temperature in degrees Celsius to nearest .1 degree C}

Values are set to 999 if missing

Screen 5

This screen displays the current temperature and dew point temperature in Fahrenheit and the relative humidity (RH).

Temp {temperature in degrees Fahrenheit to nearest .1 degree F} RH {rh value}

Dew Point {dew point temperature in degrees Fahrenheit to nearest .1 degree F}

Values are set to 999 if missing

Screen 6

This screen displays the status of the 8190 MARS fan and the system power source.

MARS Fan {OK or FAIL}

System Pwr: {AC or Battery}

If the fan fails, the 2090 CDP will stop reporting temperature and dew point.

Screen 7

This screen displays the current value in volts and counts of the auxiliary input channel.

Aux Inp {auxiliary input channel value in volts}

Counts=count value

Value is set to 99.999 if missing

Screen 8

This screen displays the values obtained from the pressure sensor in inches of mercury.

Barometric Pres inHg

P1 {pressure value 1} P2 {pressure value 2}

Values are reported to 0.001 inHg, and are set to 99.999 if missing

Screen 9

This screen displays the rainfall counter.

Rainfall {rain tip counter} tips

Counter values range from 0 to 99.

Screen 10

This screen displays the status of the 83339-A Day/Night sensor if a Model 8364-E Visibility Sensor is not installed.

Day - Night: {Day or Night}

Screen 11

This screen displays the output of the visibility sensor: extinction coefficient and status.

Vis Ext Coeff: {extinction coefficient}

Status: {OK or ERR} {eight digit sensor status code}

Screen 12

This screen displays error messages associated with the visibility sensor. If no errors are detected, the display will show:

Visibility Sensor

Configuration Normal

If an error is detected, one of the following messages will be displayed.

For Model 8364-E:	Setup Error Clean Lenses Configuration Error Data Missing 3 Headed Operation Other Error
For other models:	Clean Lenses Data Missing Vis Conf Err. Use STD 10s, 3min, ext, mi, 1200 CHECK Visibility POWER and COMM LINES

Screen 13

This screen displays fault information for the visibility sensor.

Visibility Failure
{visibility sensor decoded error(s)}

or

Visibility Sensor
{Status Normal or No input available}

Table 3 shows the visibility status codes that might be displayed when an error is detected, along with their meanings.

Screen 14

This screen displays status information for the 8364-E's Ambient Light Sensor.

Ambient Light Sensor
Status OK

or

Status Normal

or

Not Installed

or

ALS Err Clean Window

Table 3 Visibility Error Codes			
Model 8364-E		Model 8364-C	
Code	Meaning	Code	Meaning
MODE0D	Mode 0 direct error	MODE0	Mode 0 error
MODE0I	Mode 0 indirect error	MODE1	Mode 1 error
MODE1D	Mode 1 direct error	DIRECT	Direct count error
MODE1I	Mode 1 indirect error	OFFSET	Offset error
E0	Emitter 0 failure	CROSSCHK	Crosscheck error
E1	Emitter 1 failure	E0	Emitter 0 failure
D0	Detector 0 failure	E1	Emitter 1 failure
D1	Detector 1 failure	D0	Detector 0 failure
XCHK	Crosscheck error	D1	Detector 1 failure
E0HT	Emitter 0 heater failure	E0HTR	Emitter 0 heater failure
E1HT	Emitter 1 heater failure	E1HTR	Emitter 1 heater failure
D0HT	Detector 0 heater failure	D0HTR	Detector 0 heater failure
D1HT	Detector 1 heater failure	D1HTR	Detector 1 heater failure
ALHT	ALS head or Day/Night Sensor heater failure		
PS	Power supply failure		

Screen 15

This screen displays the reporting value in Candela of the Ambient Light Sensor.

Ambient Light Sensor

xxxxx Candela

or

Not Installed

Screen 16

This screen displays the status of the 8364-E's Day/Night Sensor

8364-E Day-Night

Missing

or

Day

or

Night

or

Not Installed

Screen 17

This screen displays the power status of the 8364-E.

8364-E

On Battery Power

or

On AC Power

or

Sensor Not Installed

Screen 18

This screen displays the status of the 8364-E's power supplies.

8364-E Power Supplies

OK

or

Sensor Not Installed

or

Fail {+5, +15, -15}

Screen 19

This screen displays counts of crc errors and timeout errors for the visibility sensor. A crc error indicates that data is not being received properly due to communication line problems. Timeout errors indicate that the sensor is not reporting. This may be caused by communication line problems or a fault with the sensor.

Visi00 CRC Err/Touts

{crc error counter and timeout error counter}

Screen 20

This screen displays cloud height sensor information: cloud height and sensor status.

{No Clouds Detected *or* Cloud Base {height} Ft *or* Cloud Data Missing}

Status: {OK or ERR} {four-digit sensor status}

Screen 21

This screen displays cloud height sensor status information.

Ceilometer Stat {sensor status}

{decoded sensor status message}

Screen 22

This screen displays cloud height sensor crc error counts and timeout error counts. CRC errors indicate that communication problems exist. Timeout errors indicate that the sensor is not communicating and may be caused by bad communication lines or a problem with the sensor.

Ceil00 CRC Err/Touts
 {crc error counter and timeout error counter}

Screen 23

This screen displays the current present weather sensor data.

Present Weather Data
 {present weather sensor information}

Present weather data is in the format

WwwPppppSssss

where:

ww is the present weather code (see **Table 4**)
 pppp is the rain rate in .001 inches per hour
 ssss is the sensor status word, normally 0000.

Screen 24

This screen displays the status values from the present weather sensor.

Present Weather Stat
 {present weather status codes}

Present weather status is in the format:

XnnnLnnnKnnnHnnnTnnn

where: nnn is a three digit number

- X indicates the start of the carrier raw data field
- L indicates the start of the low raw data field
- K indicates the start of the particle raw data field
- H indicates the start of the high raw data field
- T indicates the start of the temperature field

**Table 4
 Present Weather Codes
 as reported by Model 6490**

Code	Meaning
L-	Light Drizzle
L	Moderate Drizzle
L+	Heavy Drizzle
R-	Light Rain
R	Moderate Rain
R+	Heavy Rain
P-	Light Precipitation
P	Moderate Precipitation
P+	Heavy Precipitation
S-	Light Snow
S	Moderate Snow
S+	Heavy Snow
ZL	Freezing Drizzle
	Freezing Rain
I-	Light Ice Pellet (optional)
I	Moderate Ice Pellet (optional)
I+	Heavy Ice Pellet (optional)
A-	Light Hail (optional)
A	Moderate Hail (optional)
A+	Heavy Hail (optional)
	No Precipitation
—	Start-Up Indicator
ER	Error Condition
CL	Lenses require cleaning

Screen 25

This screen contains status information from the present weather interface computer. CRC errors indicate that the computer is communicating, but not correctly. It may indicate problems with the communications line. Timeout errors indicate that no data was received from the sensor when expected.

PRWX00 CRC Err/Touts
 {crc error counter and timeout error counter}

Screen 26

This screen displays information about the data being received from the present weather sensor. BCC errors indicate that the sensor is communicating, but not correctly. The input message counter (“Inctr”) shows the number of data packet requests from the DCP to the sensor since power-up.

PRWX00 BCC Err/Inctr
 {present weather sensor internal crc error counter and input message counter}

Screen 27

This screen contains the counts for the Analog to Digital negative and positive reference voltages. These are normally 0 and 4095.

ADC Vref- {adc high reference count}
 ADC Vref+ {adc low reference count}

Screen 28

This screen reports any detected lightning strikes within 10 miles of the installation site. If the strikes are less than 5 miles away, “TS Reported” will be displayed. This will be voiced in the AWOS voice output as “Thunderstorm at the airport”. If the strikes are within 5-10 miles, “VCTS Reported” will be displayed. This will be voiced in the AWOS voice output as “Thunderstorm in the vicinity”. If no strikes are detected, the message “No Strikes < 10 mi” will be displayed. This screen is updated every minute.

Lightning Sensor Pg1
 {"TS Reported" or "VCTS Reported" }

Screen 29

This screen reports any detected lightning strikes more than 10 miles from the installation site, up to 30 miles away. If no strikes are detected, the message “No Strikes > 10 mi” will be displayed. If the data string exceeds the LCD’s capacity (20 characters), the data will be continued on the next screen (**Screen 30**). This screen is updated every minute.

Lightning Sensor Pg2
 {"LTG_DSNT_" followed by direction in octants}

Screen 30

This screen displays data continued from the previous screen when the amount of data for the 10-30 mile range exceeds the LCD’s 20-character capacity. If the data does not exceed 20 characters, this screen is a duplicate of **Screen 29**.

Lightning Sensor Pg3
 {"LTG_DSNT_" followed by direction in octants}

Screen 31

This screen reports the number of strikes detected within the full measuring area (200 nautical mile radius of the installation site) during the previous one minute. The value is reported in strikes per minute.

If no strikes were detected, the message “Strike Rate none” will be displayed. This screen is updated every minute.

Lightning Sensor Pg4
 {number of strikes recorded during previous 1 minute}

Screen 32

This screen shows the current operating mode of the sensor. This should always read “Normal Weather Data”, unless the sensor fails or is disconnected, in which case it will read “Sensor Not Reporting”.

Lightning Sensor Pg5
 Normal Weather Data

Screens 33 and 34

These two screens show the most recent status message received from the lightning sensor. The format of the status message is explained in the Model 6500 User's Manual. Due to the length of the message, it is split between two screens.

Lightning Sensor Pg6
{first 17 characters of status message; e.g.,
SPE00MAG@XXN00000}

Lightning Sensor Pg7
{remaining 11 characters of status message; e.g.,
R0000VB1.03}

Screen 35

The final lightning sensor status screen shows the number of CRC errors and timeouts detected since the sensor was last powered up.

LTNG00 CRC Err/Touts
{number of CRC errors/number of timeouts}

Screen 36

This screen shows the most recent freezing rain count. This is the probe's oscillating frequency, which is normally 40,000 Hz in non-icing conditions.

Freezing Rain Count
{probe frequency, in Hz, e.g., 40000 Hz}

Screen 37

This screen shows the freezing rain status. This should normally indicate "Sensor OK". If an error is detected, the screen will show the type of failure (e.g., "Probe Failure")..

Freezing Rain Status
Sensor OK

Screen 38

This screen shows the number of CRC errors and timeouts detected since the sensor was last powered up. CRC errors indicate that the computer is communicating, but not correctly. It may indicate problems with the communications line. Timeout errors indicate that no data was received from the sensor when expected.

ZR CRC Err/Touts
{number of CRC errors/number of timeouts}

Screen 39

This screen shows the number of deicing cycles initiated since power-up, along with the number of sensor CRC errors ("BccErr") and the number of data packet requests ("Inctr") from the DCP to the sensor since power-up.

ZR Deic/BccErr/Inctr
{number of deice cycles/sensor internal crc error counter/input message counter}

Screen 40

This screen contains information transmitted from the Central Data Processor every five seconds. Line one contains the airport identifier, date, and time. If communications are normal, the time should update every five seconds.

CDP information line 1 {airport identifier, date, time}
CDP information line 2 {other information from the CDP}

Screen 41 (A-C)

This series of screens is available when the maintenance switch has been pressed to allow testing of the data link radio.

Screen A

Data link radio test

Press 1 to continue

Pressing 1 calls up Screen B to start the test. Pressing any other key bypasses the test.

Screen B

(appears if 1 was pressed at Screen A)

Idle: Press 2 to start

Press 2 to begin the test.

Screen C

Xmit: Any key = Stop

While this screen is displayed, the radio will transmit for 60 seconds or until a key is pressed to stop the transmission.

Screen 42

This screen allows the keypad to be tested. It appears only when the maintenance switch has been pressed.

Keypad test. # = Exit

Press any key to test the keypad. The key's value will appear on the second line of this screen. (*Note: Pressing the * key will cause a decimal point to be displayed.*) When done, press the # key to end the test.

Screen 43 (A-C)

This series of screens allows a Model 8364-E Visibility Sensor to be calibrated using the 1190 DCP's built-in keypad and display. This series of screens is only displayed when a Model 8364-E is installed and communicating properly, and the maintenance switch has been pressed.

Screen A

Cal 8364E Vis Sensor

1 to Cont or # to Exit

Screen B

(appears if 1 was pressed at Screen A)

Enter Cal ID * for .

when done

Enter the calibration number from the Visibility Sensor's calibration paddle. To enter a decimal point, press the * key. Press the # key when done.

Screen C

Cal ID is XXXXXX

Press # if OK

If the displayed calibration number is correct, press the # key to continue to the next screen. Follow the on-screen instructions on the remaining screens to complete the calibration process.

Screen 44

This screen allows you to run a series of diagnostic tests on the 8364-E Visibility Sensor, and is displayed when an 8364-E is installed and communicating properly, and the maintenance switch has been pressed. The tests include:

- RAM test
- ROM Test
- Power Supply Test
- NVRAM Test
- Mode tests

Test 8364-E Sensor

1 to Cont. or # to Exit

Press 1 to initiate the tests, or press # to bypass them. If you choose to run the tests, follow the instructions on the succeeding screens until the test cycle is complete.

Screen 45 (A-C)

Note: The following ALS calibration procedure requires specialized equipment and facilities and should normally only be performed at the factory.

This series of screens allows a Model 8364-E Visibility Sensor's Ambient Light Sensor (ALS) to be calibrated using the 1190 DCP's built-in keypad and display. These screens are only displayed when a Model 8364-E with ALS is installed and communicating properly, the maintenance switch has been pressed, and the DCP's address switch is not set to address 0.

Screen A

Cal 8364E ALS Sensor

1 to Cont, # to Exit

Screen B

(appears if 1 was pressed at Screen A)

Enter CalID * for .

when done XXXX.X

Enter the cal standard light level from the photometer in Candela. To enter a decimal point, press the * key. Press the # key when done.

Screen C

CalID is XXXXXX

Press # if OK

If the displayed number is correct, press the # key to continue to the next screen. Follow the on-screen instructions on the remaining screens to complete the ALS calibration process.

LED Indicators

The DCP backplane is equipped with seven LED indicators, which provide a visual clue to the activity and status of several portions of the DCP circuitry.

PWR. IN

The green **PWR. IN** LED is lighted when a +15VDC power source is connected to TB4, pins 5 and 6.

BATT. CHARGE

The green **BATT. CHARGE** LED is lighted when the backup 12V battery (if present) is fully charged.

STATUS

The green **STATUS** LED is not currently used.

RS-485 TX/RX

The red **RS-485 TX/RX** LED lights when data is being transmitted to or received from the CDP via the RS-485 port.

RS-232 RX

The red **RS-232 RX** LED lights when data is being received from the CDP via the RS-232 port.

RS-232 TX

The red **RS-232 TX** LED lights when data is being transmitted to the CDP via the RS-232 port.

FLOAT CHARGE

The red **FLOAT CHARGE** LED lights when the 12V rechargeable battery (if used) is in the final charging stages. It is also lighted when no battery is connected.

4. CALIBRATION

No calibration is required with the Model 1190 Data Collection Platform.

5. MAINTENANCE

No regular maintenance is required with the Model 1190 Data Collection Platform, other than verifying periodically that all cables are connected and in good condition.

A 0.5 A slow-blow fuse protecting a connected MARS (Motor Aspirated Radiation Shield) is located at F1 on the DCP backplane. This should be checked if a MARS failure is detected.

When performing maintenance on any other part of the system, remember to press the maintenance switch (SW3) prior to beginning maintenance as explained in the *Operation* chapter of this manual.

6. WARRANTY

This equipment has been manufactured and will perform in accordance with requirements of FAA Advisory Circular 150/5220-16C. Any defect in design, materials, or workmanship that may occur during proper and normal use during a period of 1 year from date of installation or a maximum of 2 years from shipment will be corrected by repair or replacement by All Weather Inc.

7. SPECIFICATIONS

Supply Voltage..... 110/220 V AC
 Operating Temperature -40° to +60°C
 Storage Temperature -40° to +60°C
 Display 2 line × 20 character LCD

Fuses

Backplan

F1 (MARS)..... 0.5 A, 250 V slow-blow

Power Interface Board

F1..... 10 A, 250 V slow-blow

F2..... 5 A, 250 V slow-blow

Supported Sensors

Model 2100, 2040/2040H/2040HH, and Model 2020/2030 Wind Sensors

Model 5190 Temperature and Relative Humidity Sensor

Model 8190 Motor Aspirated Radiation Shield (MARS)

Model 7190 Barometric Pressure Sensor

Model 6011-A/B and 6021-A/B Rain Gauges

Model 83339-A Day/Night Sensor

Model 8360, 8362-A/B, 8364-A/B/C/D/E Visibility Sensors

Model 8329-A/B Ceilometer

Model 8339-D/F Ceilometer

Model 6490 (OWI-120) Present Weather Sensor

Model 6495 Freezing Rain Sensor

Model 6500 Thunderstorm/Lightning Sensor

M403326 Day/Night Sensor (with 8364-E only)

M105068 Ambient Light Sensor (with 8364-E only)

One auxiliary voltage input sensor (0–10 V DC)

Communication (to/from CDP)..... RS-232, RS-485, UHF radio

Size 15"W × 16.5"H × 6.25"D (38 cm × 42 cm × 16 cm)

Weight 15 lbs. (6.8 kg)

8. DRAWINGS

The following pages contain drawings to aid in the use and maintenance of the Model 1190 DCP.

M403316-003

M403316-019

1190-007

M404802-003

M404802-004

903-E-019

903-HH-019

3000-A-019

3000-B-019

NOTES: UNLESS OTHERWISE SPECIFIED;

* SEE SHEET 6 FOR NOTES.

REVISIONS			DWG NO. M403316-003	
REV	ECN	DESCRIPTION	DATE	APPROVED
H	4922	SHT 2, DETAIL E, ITEM 9 WAS ITEM 7		
J	5036	SHT 5: SWAP BATT WIRES AND ADD HEAT SHRINK LENGTH	12-9-04	JCONNER
K	5145	ADD NOTE 16 ON SHT 6	9-30-05	BRG
L	0566	ADD SHT. 8, ULTRASONIC DCP I/F KIT	11-10-05	BRG
M	0656	ADDED 11902-B TO SHT.4	6-7-06	BRG
N	0832	CHG PWR CBL TERM FROM: TB2-5, -7 TO: TB2-9, -10	12-21-06	PMK
P	0982	REPLACE DCP PWR SUPPLY W/MORE RELIABLE VERSION	1-17-06	PMK
Q	0868	SWAP BLK AND WHT WIRE DESIG FOR RS232 CBL, SHT 8	7-03-07	PMK
R	1158	BLU GILL SNSR WIRE SHOULD HOOK UP TO "SG" TERMINAL	9-13-07	PMK
S	1194	CONV PWR NOW COMES FROM 11905-G	10-16-07	BRG
T	1219	RELOCATED BATTERY, RE-ROUTE BP & RADIO CABLE	8/28/08	BRG
U	1400	ADDED FASTENERS FOR 7 AMP XFMR	12-30-08	J.CONNER
V	1745	REVISED SHT.8, GILL DC PWR CONNECTION	9/9/09	BRG
W	1938	UPDATED DCP BOX	03/24/10	TI

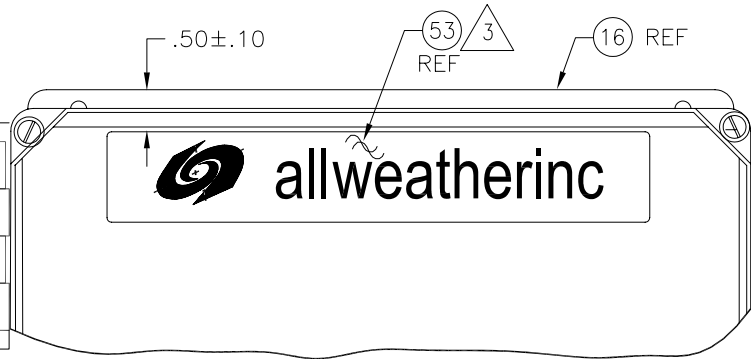

DETAIL N
DETAIL OF FRONT COVER
SHOWING PLACEMENT
OF LABEL ITEM 53

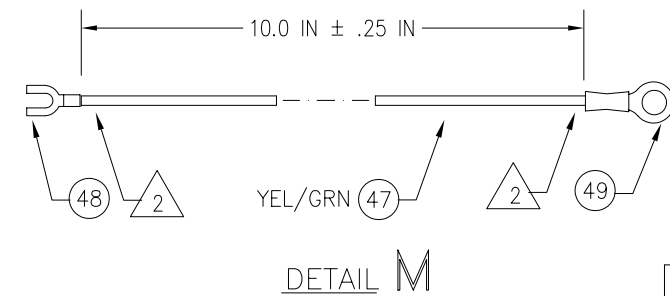
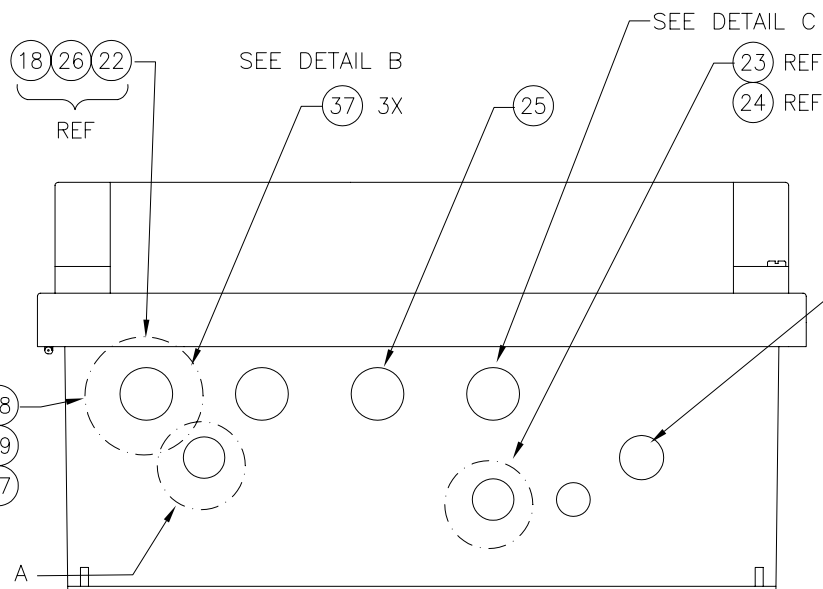
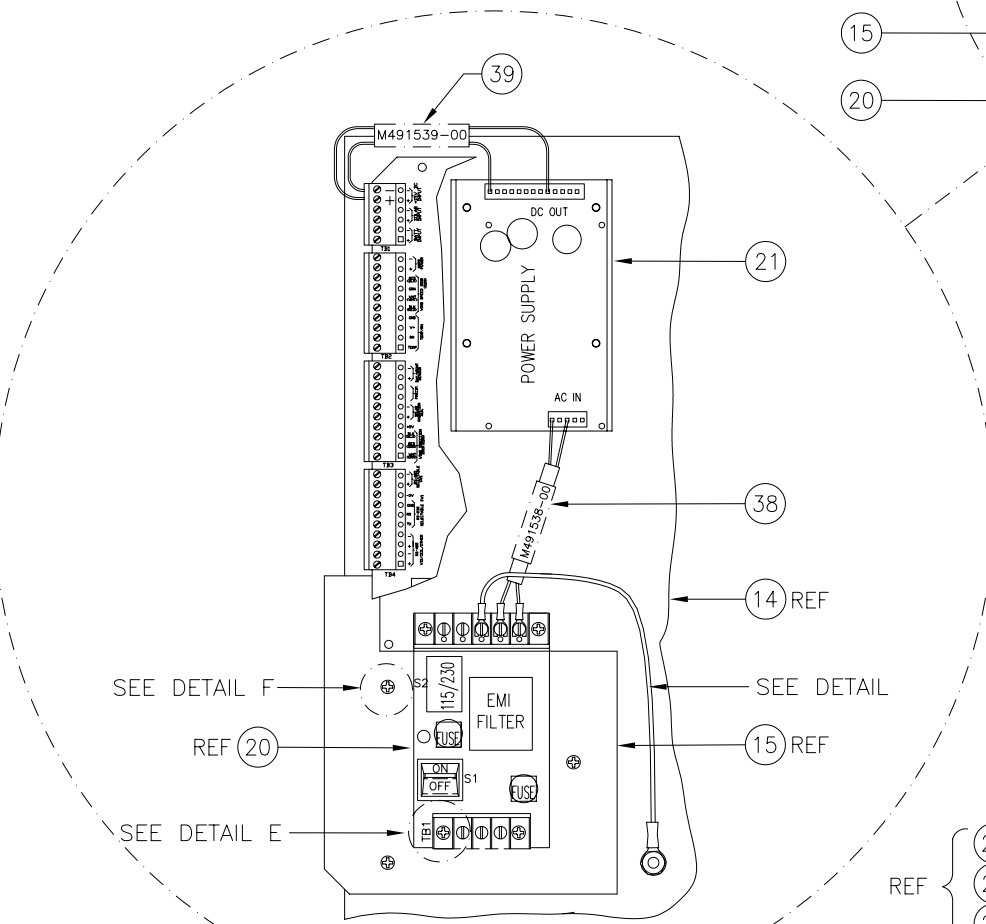
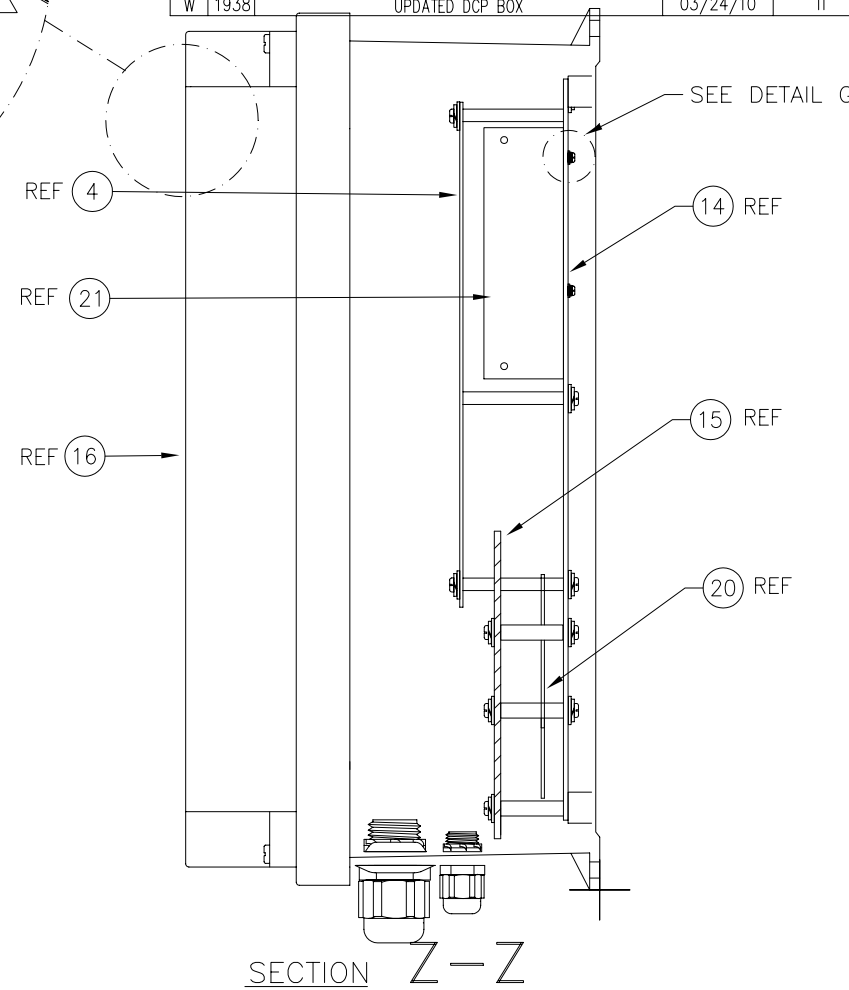
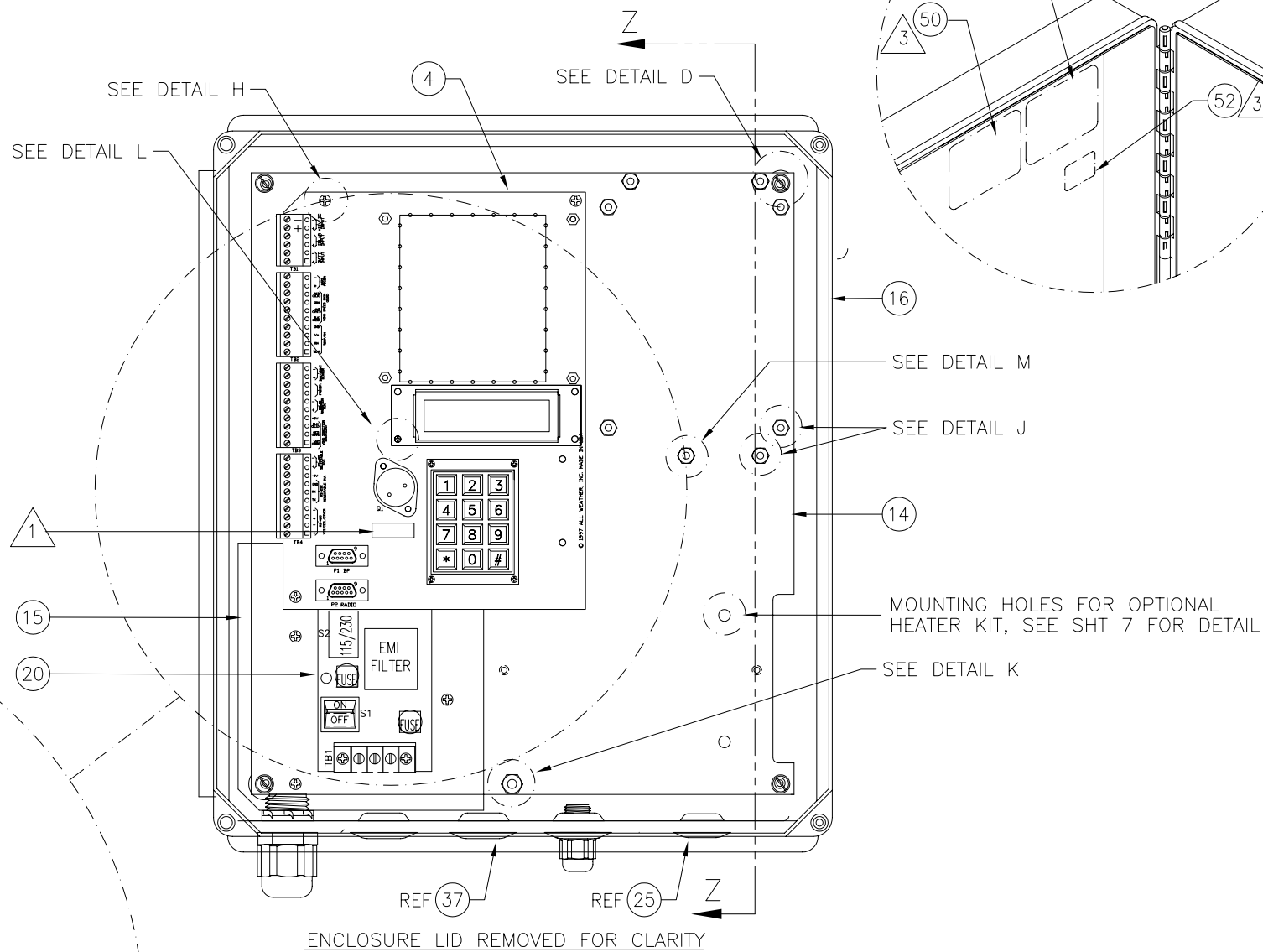

EXCEPT AS MAY OTHERWISE BE SPECIFIED BY CONTRACT, THIS DOCUMENT AND THE DATA DISCLOSED HEREIN AND HEREWITH, IS NOT TO BE USED, REPRODUCED OR DISCLOSED, IN WHOLE OR IN PART, TO ANYONE WITHOUT THE WRITTEN PERMISSION OF ALL WEATHER INC..

APPEND THE FOLLOWING DOCUMENTS WHEN CHANGING THIS DOCUMENT:		UNLESS OTHERWISE SPECIFIED: DIMENSIONS ARE IN INCHES TOLERANCES XX=±.010 ANGLES ±1/2° XXX=±.005 CONCENTRICITY: .003 TIR DO NOT SCALE DRAWING		DRAWN BY: P Kooyman 21July97		TITLE ASSEMBLY DRAWING, AWOS DCP	
		MATERIAL SEE BILL OF MATERIALS		REVISED BY: T IWANOWSKI 03/24/10		DWG NO. M403316-003	
		FINISH AS ISSUED		CHECKED BY:		SCALE 1/2	
		TREATMENT		DESIGN ENGINEER: J CONNER 21OCT97		RELEASE DATE 21OCT97	
				PROJECT MANAGER: JJ SPOTTS 21OCT97		SHEET 1 OF 8	
				APPROVALS		DATE	

W	W	W	W	W	W	W	W	REV	REV
8	7	6	5	4	3	2	1	SHEET	STATUS
									OF SHEETS



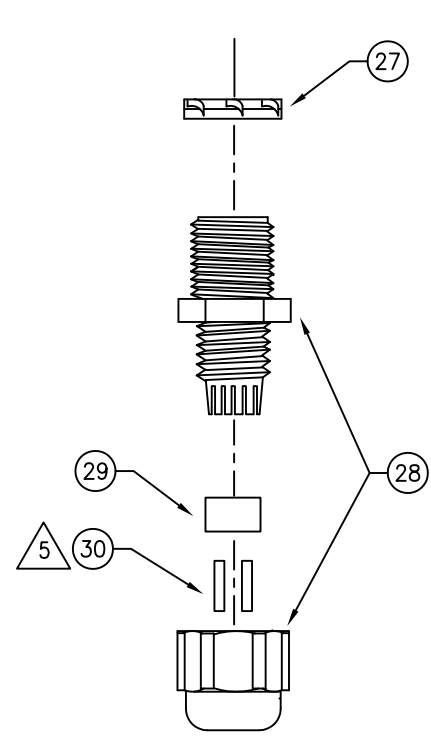

DETAIL A

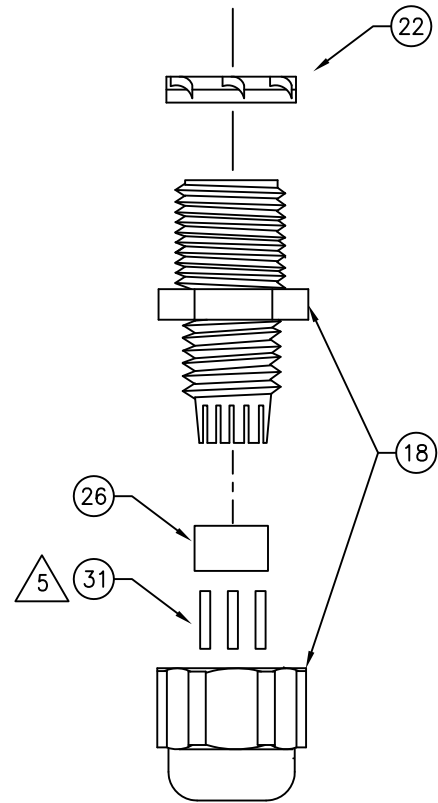

DETAIL B

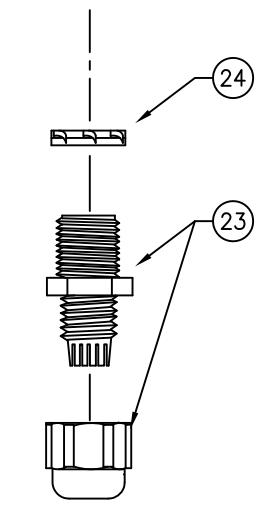

DETAIL C

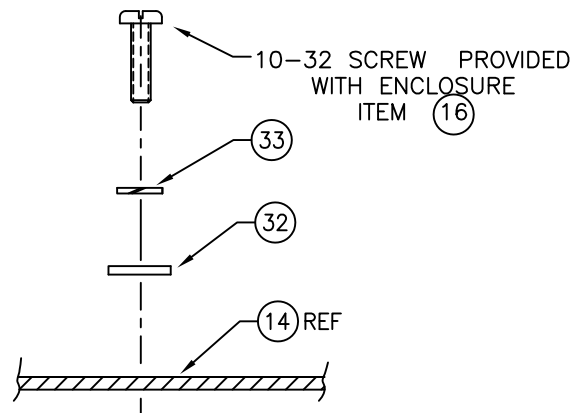

DETAIL D
4 PLACES

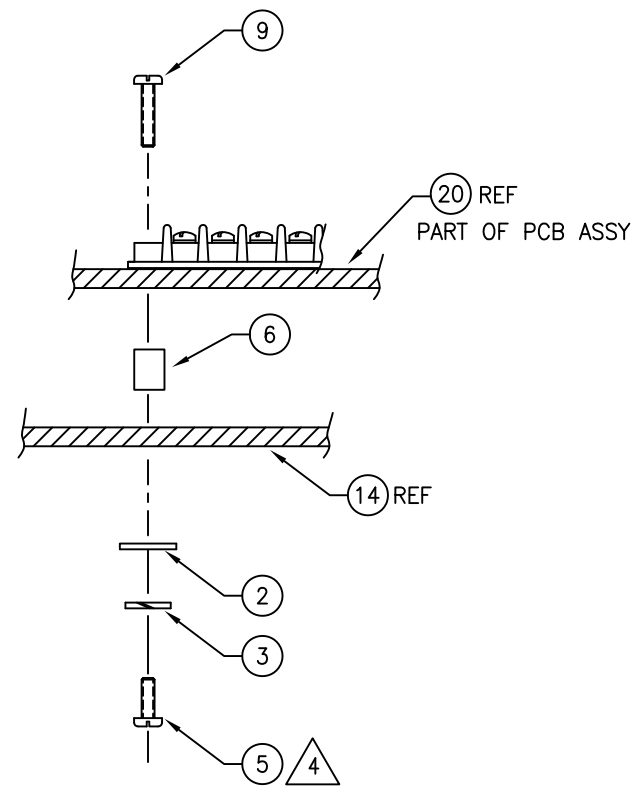

DETAIL E
4 PLACES

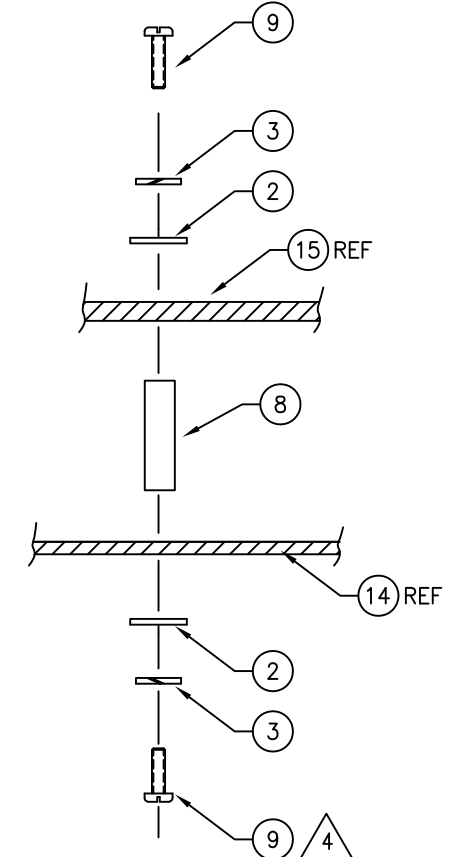

DETAIL F
3 PLACES

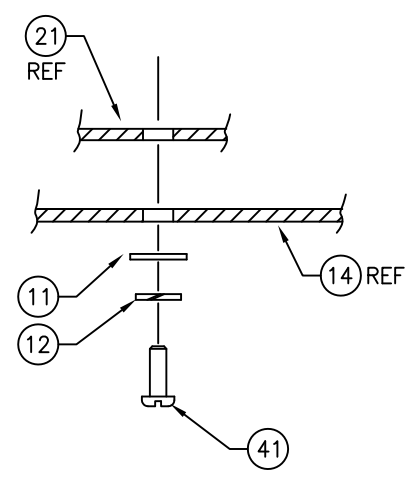

DETAIL G
HARDWARE MOUNTING
FOR ITEM (21)
4 PLACES

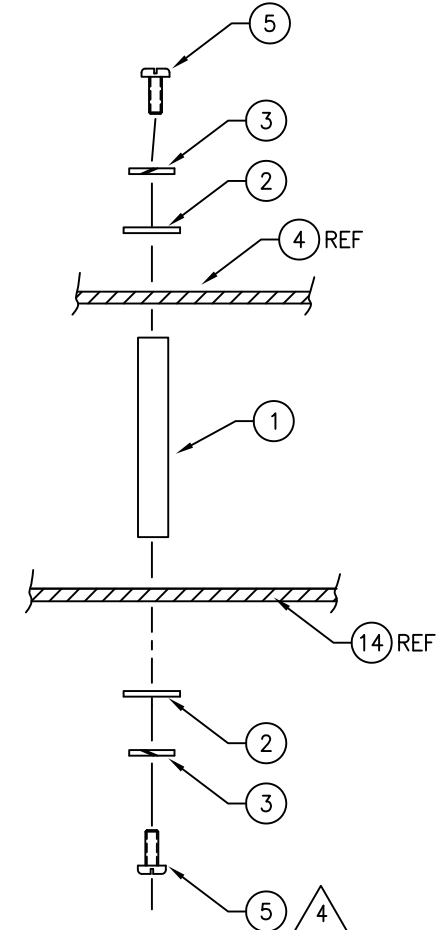

DETAIL H
4 PLACES

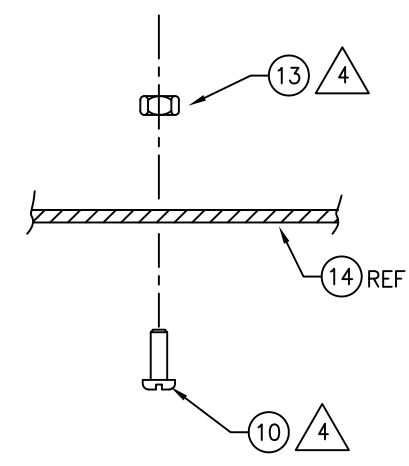

DETAIL J
7 PLACES
HARDWARE MOUNTING FOR
OPTIONAL BP SENSOR
AND OPTIONAL 7 AMP XFMR

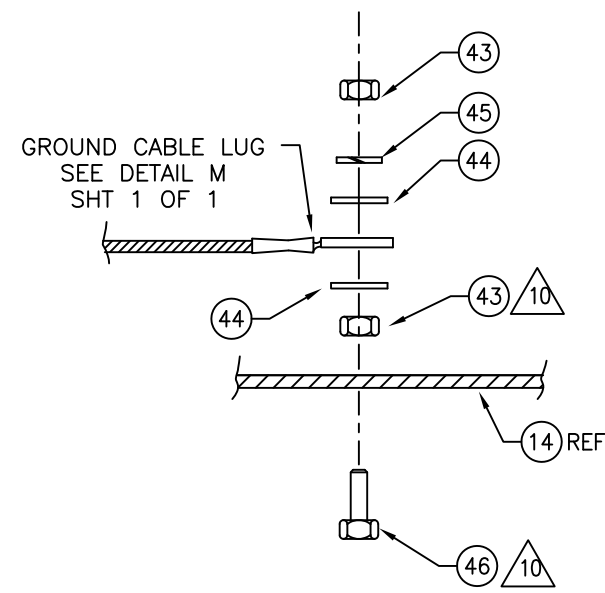

DETAIL K
HARDWARE MOUNTING
FOR GROUND CABLE

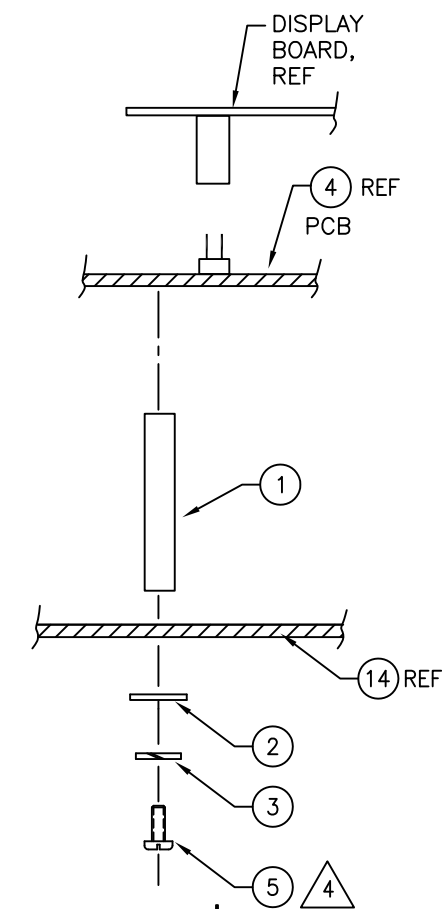

DETAIL L

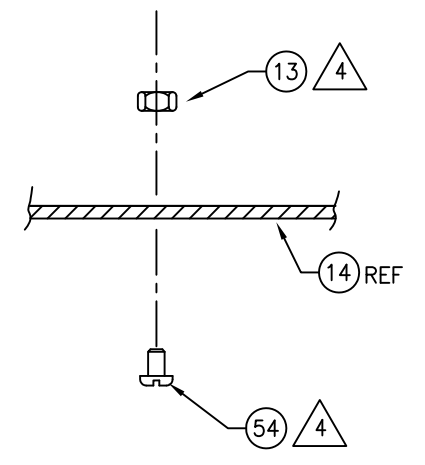

DETAIL M
1 PLACE

EXCEPT AS MAY OTHERWISE BE SPECIFIED BY CONTRACT, THIS DOCUMENT AND THE DATA DISCLOSED HEREIN AND HEREWITH, IS NOT TO BE USED, REPRODUCED OR DISCLOSED, IN WHOLE OR IN PART, TO ANYONE WITHOUT THE WRITTEN PERMISSION OF ALL WEATHER, INC..

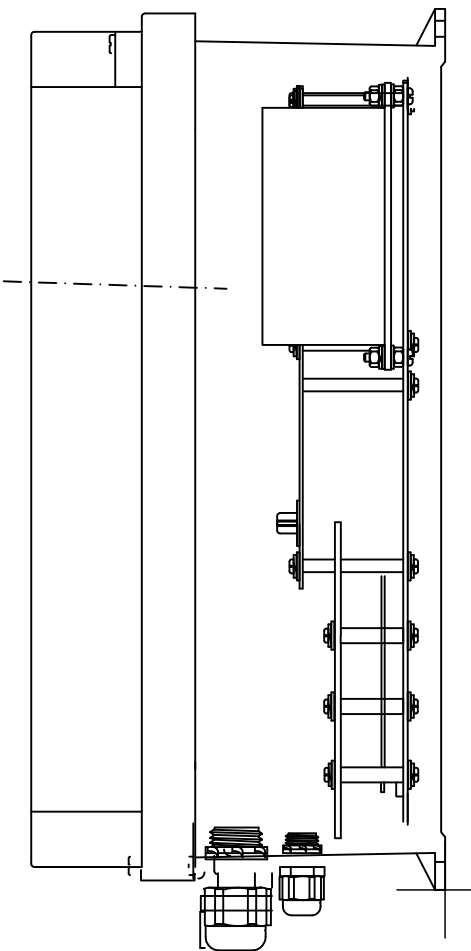
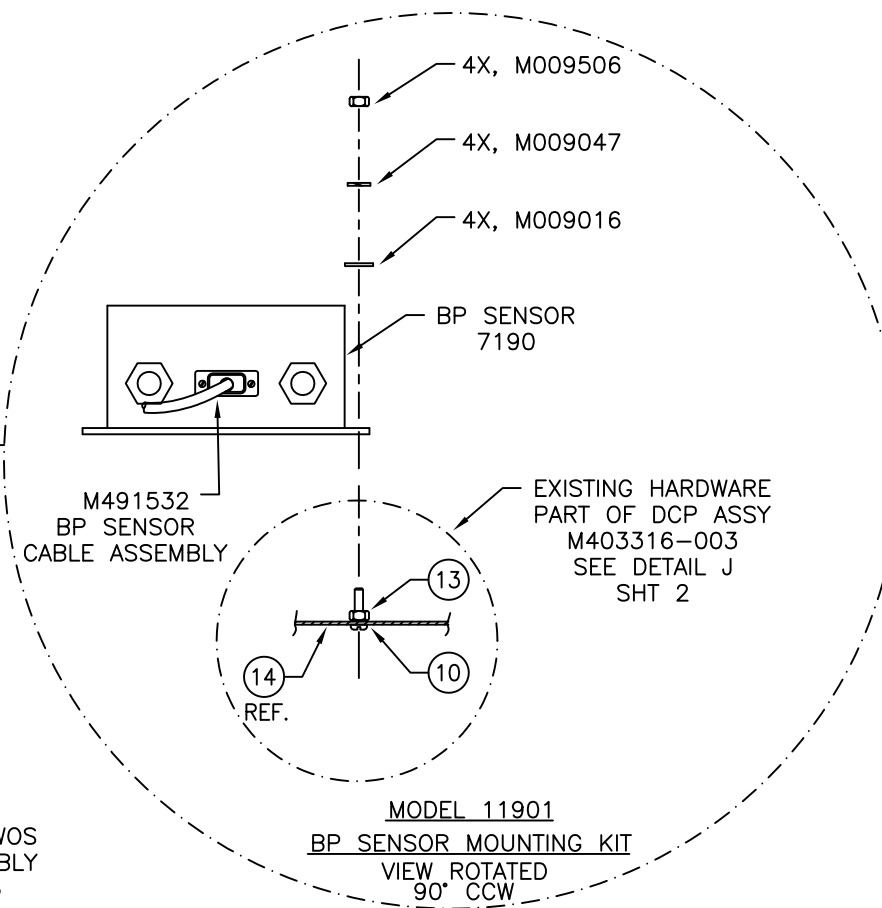
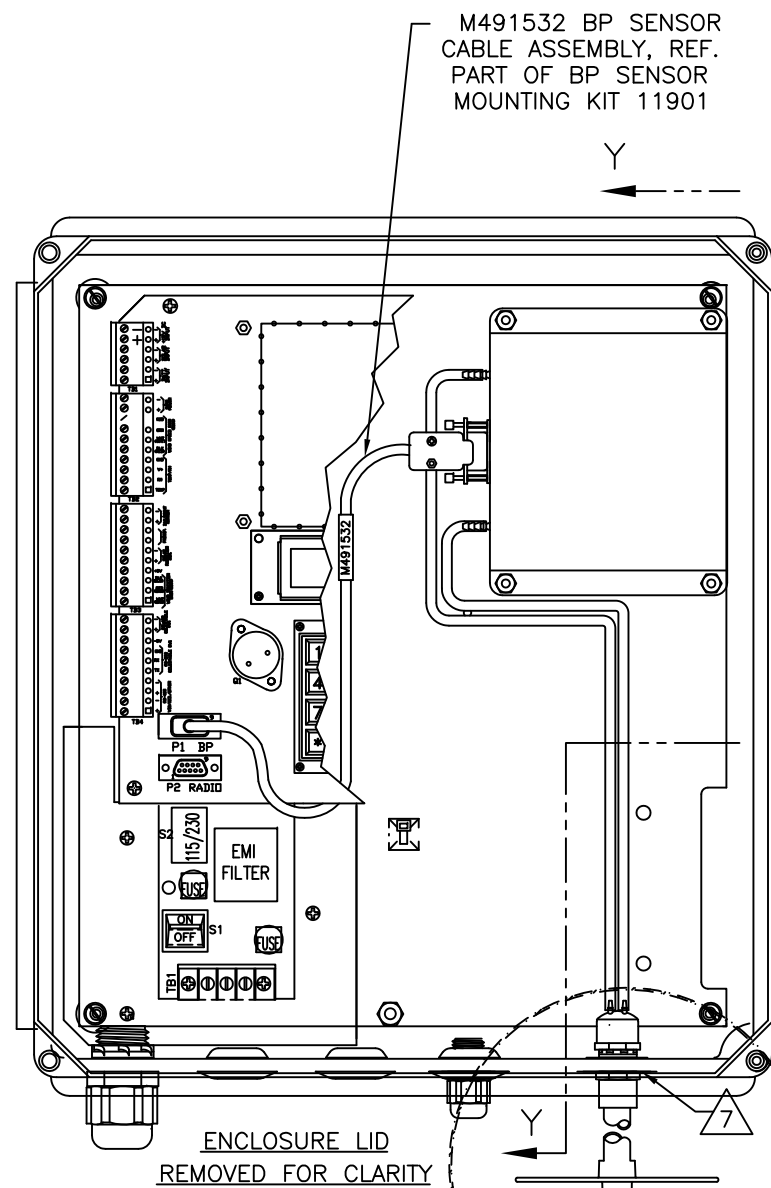

SECTION Y-Y

MODEL 11901
BP SENSOR MOUNTING KIT

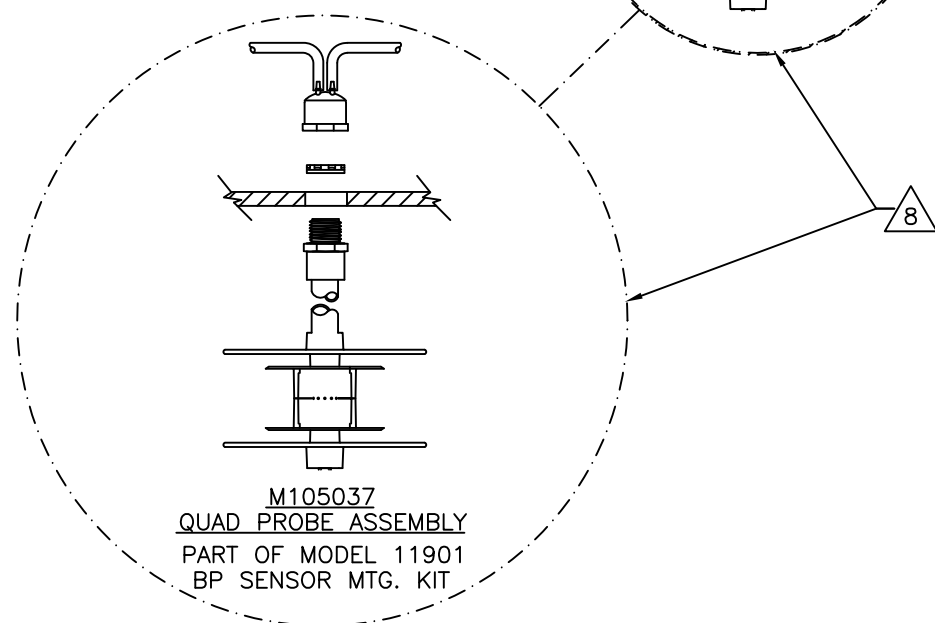

EXCEPT AS MAY OTHERWISE BE SPECIFIED BY CONTRACT, THIS DOCUMENT AND THE DATA DISCLOSED HEREIN AND HEREWITH, IS NOT TO BE USED, REPRODUCED OR DISCLOSED, IN WHOLE OR IN PART, TO ANYONE WITHOUT THE WRITTEN PERMISSION OF ALL WEATHER, INC..

SIZE	DWG NO.
D	M403316-003
SCALE	REV LTR
1/2	W
SHEET	3 OF 8

EXISTING AWOS
DCP ASSEMBLY
M403316

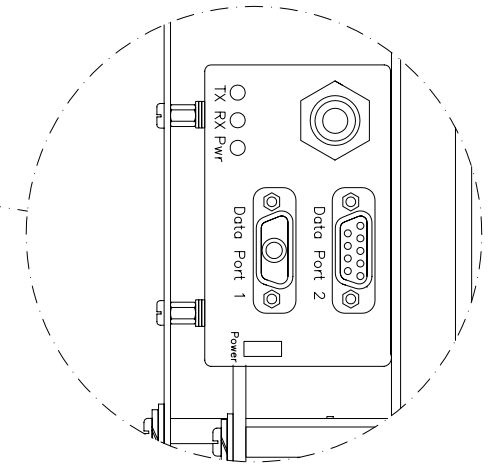
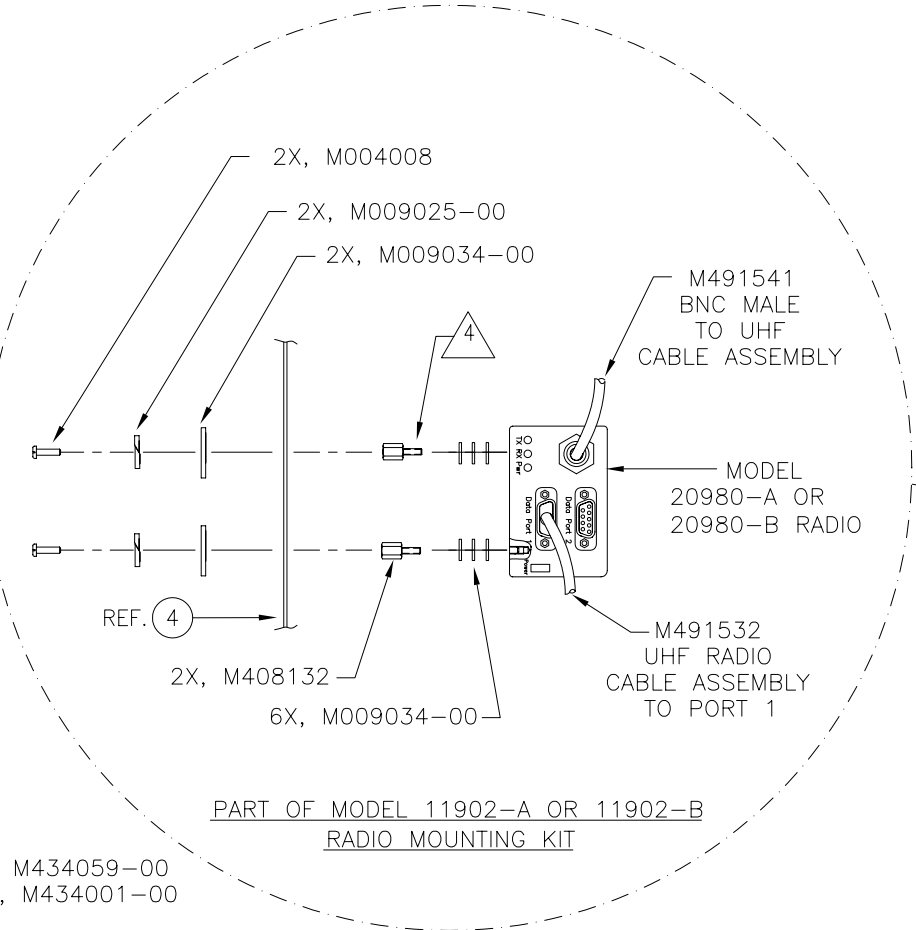
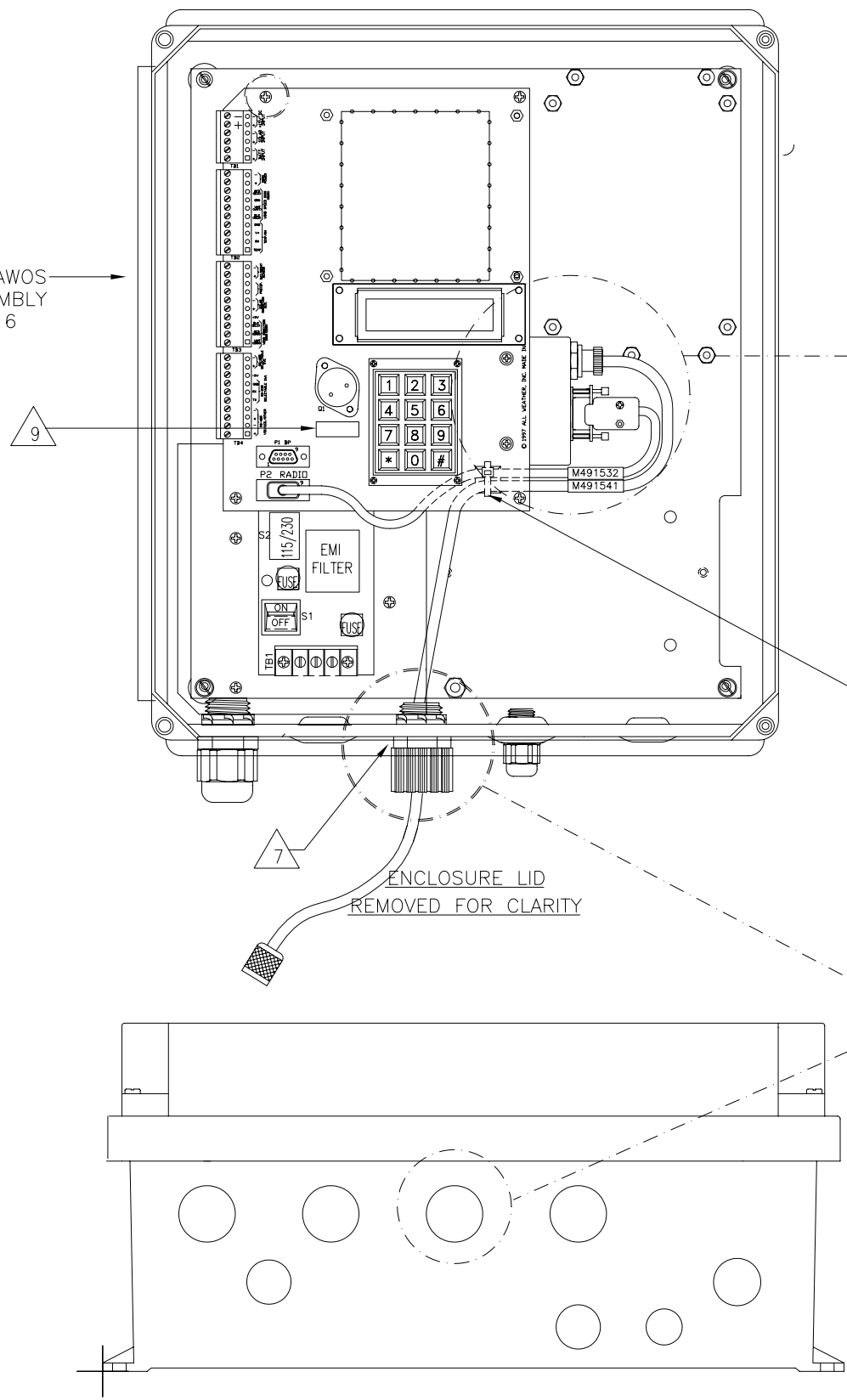

CABLE TIE, M434059-00
TIE MOUNT, M434001-00

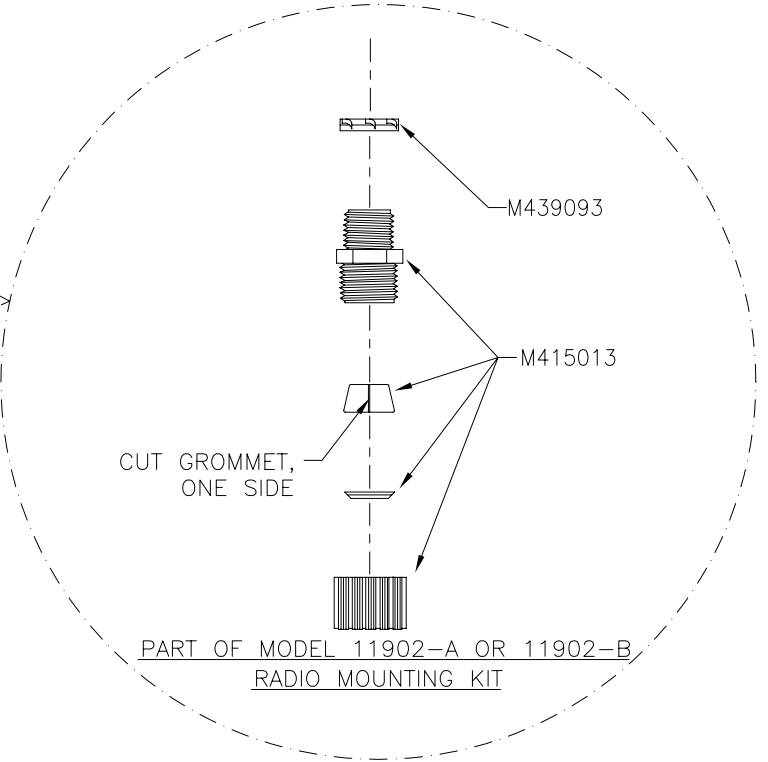

MODEL 11902-A OR 11902-B
RADIO MOUNTING KIT

EXCEPT AS MAY OTHERWISE BE SPECIFIED BY CONTRACT,
THIS DOCUMENT AND THE DATA DISCLOSED HEREIN
AND HEREWITH, IS NOT TO BE USED, REPRODUCED OR
DISCLOSED, IN WHOLE OR IN PART, TO ANYONE WITHOUT
THE WRITTEN PERMISSION OF ALL WEATHER, INC..

SIZE D	DWG NO. M403316-003
SCALE 1/2	REV LTR W
SHEET 4 OF 8	

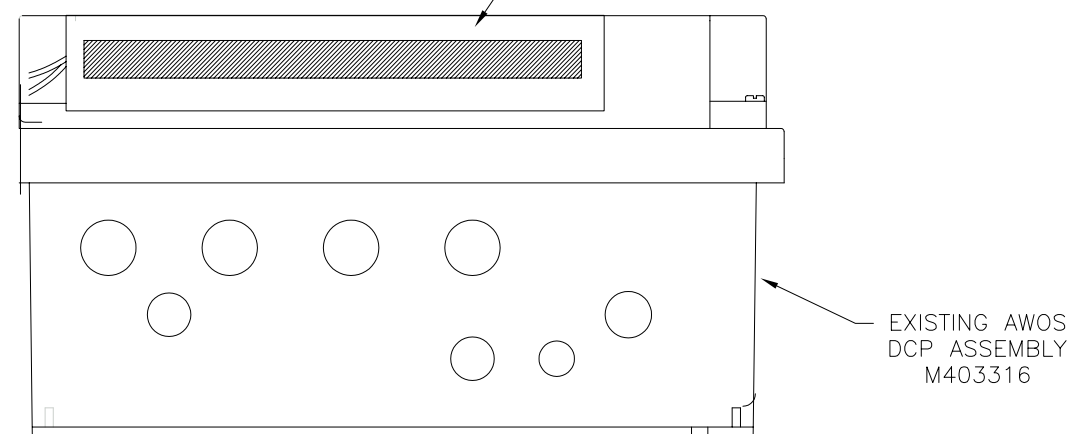
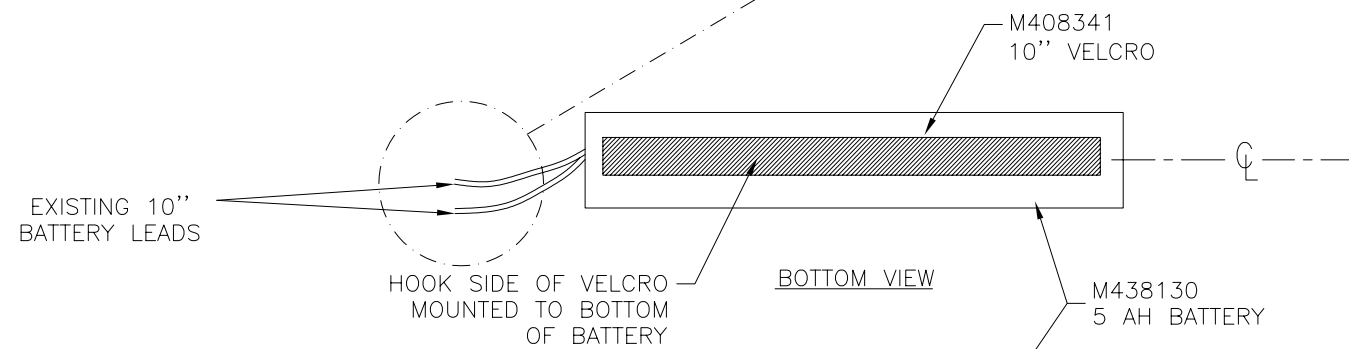
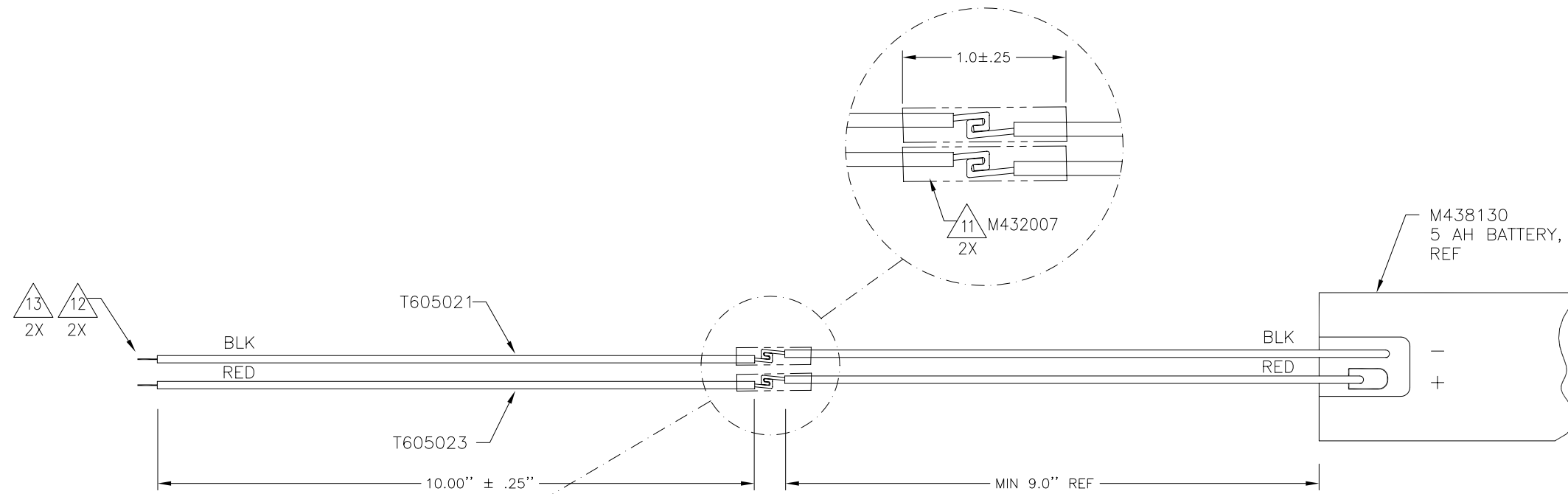

ENCLOSURE BOTTOM VIEW
ENCLOSURE LID SHOWN AS
A SECTION FOR CLARITY

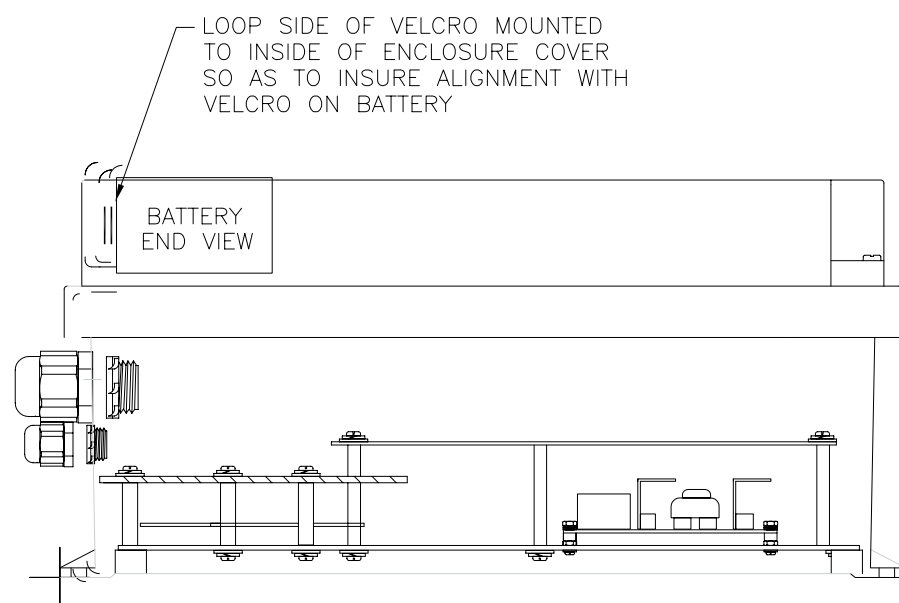

ENCLOSURE SIDE VIEW SECTION

THIS DOCUMENT AND THE DATA DISCLOSED HEREIN AND HEREWITH, IS NOT TO BE USED, REPRODUCED OR DISCLOSED, IN WHOLE OR IN PART, TO ANYONE WITHOUT THE WRITTEN PERMISSION OF ALL WEATHER, INC..

BATTERY KIT
11903

SIZE	DWG NO.
D	M403316-003
SCALE	REV LTR
1/2	W
SHEET	5 OF 8

NOTES: UNLESS OTHERWISE SPECIFIED;

- 1 SET DIP SWITCH, SW1, ON ITEM 4, TO "RS-485" SETTINGS PER SILK SCREEN SETTINGS ON BOARD. (SET TO "UHF RADIO" WHEN RADIO OPTION IS INSTALLED).
- 2 REMOVE (.25 \pm .00 / .10) INSULATION, THIS END.
- 3 INSTALL LABELS ITEM 50, 51 AND 52 ON THE INSIDE OF THE UPPER RIGHT HAND CORNER OF ENCLOSURE COVER. INSTALL LABEL ITEM 53 ON THE OUTSIDE OF ENCLOSURE COVER.
- 4 APPLY A SMALL AMOUNT OF LOCTITE 222.
- 5 CUT TO 1" LONG AT ASSEMBLY. INSERT INTO BUSHING, (ITEM 29 ON 26) FOR PLUGS.
- 6 DELETED
- 7 REMOVE HOLE PLUG.
- 8 DO NOT INSTALL THESE PARTS. PACKAGE AND SHIP WITH UNIT TO BE INSTALLED LATER.
- 9 SET DIP SWITCH, SW1, ON ITEM 4, TO "UHF RADIO" SETTINGS PER SILK SCREEN SETTINGS ON BOARD.
- 10 APPLY A SMALL AMOUNT OF LOCTITE 242.
- 11 HOOK SPLICE AND COVER WITH HEAT SHRINK TUBING, M432007.
- 12 REMOVE (.38 \pm .00 / -.10) INSULATION, THIS END. TIP TIN ONLY.
- 13 COVER WITH REMOVABLE TAPE TO PREVENT SHORTING OF BATTERY.
- 14 CONN. H1 ON DAUGHTER BOARD CONNECTS TO H4 ON DAUGHTER BOARD AS SHOWN.
- 15 CONN. H1 ON DAUGHTER BOARD CONNECTS TO H6 ON MOTHER BOARD AS SHOWN.
- 16 ENSURE EACH APPROPRIATE SENSOR INTERFACE MODULE (11905-X) ARE LABELED PER INSTRUCTIONS ON LABEL SET.

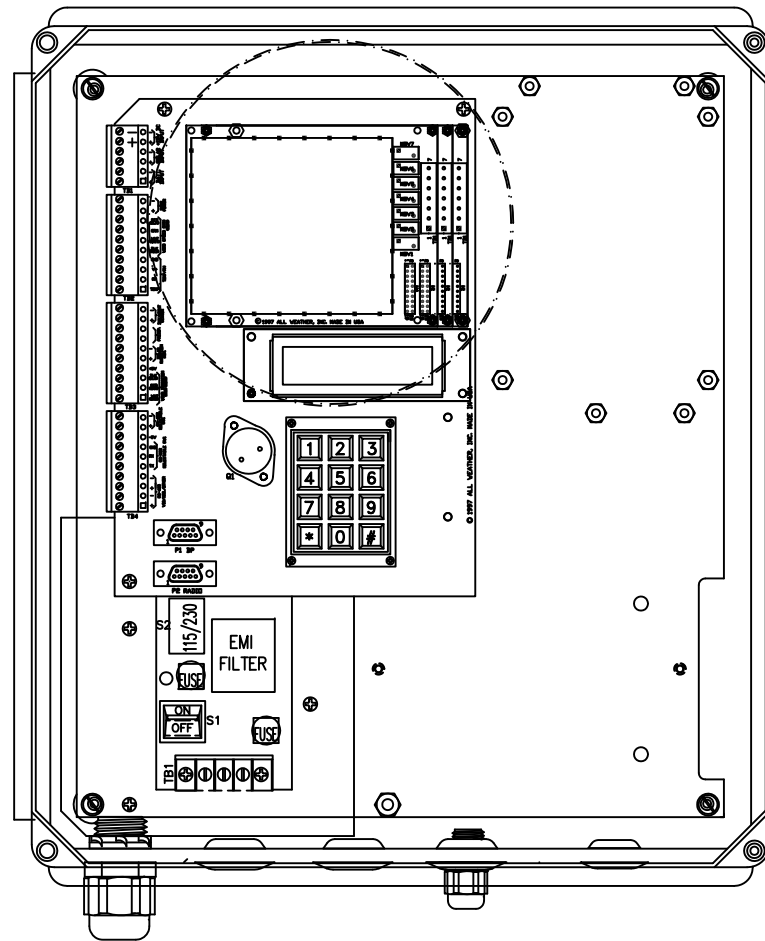

ENCLOSURE FRONT VIEW LID REMOVED

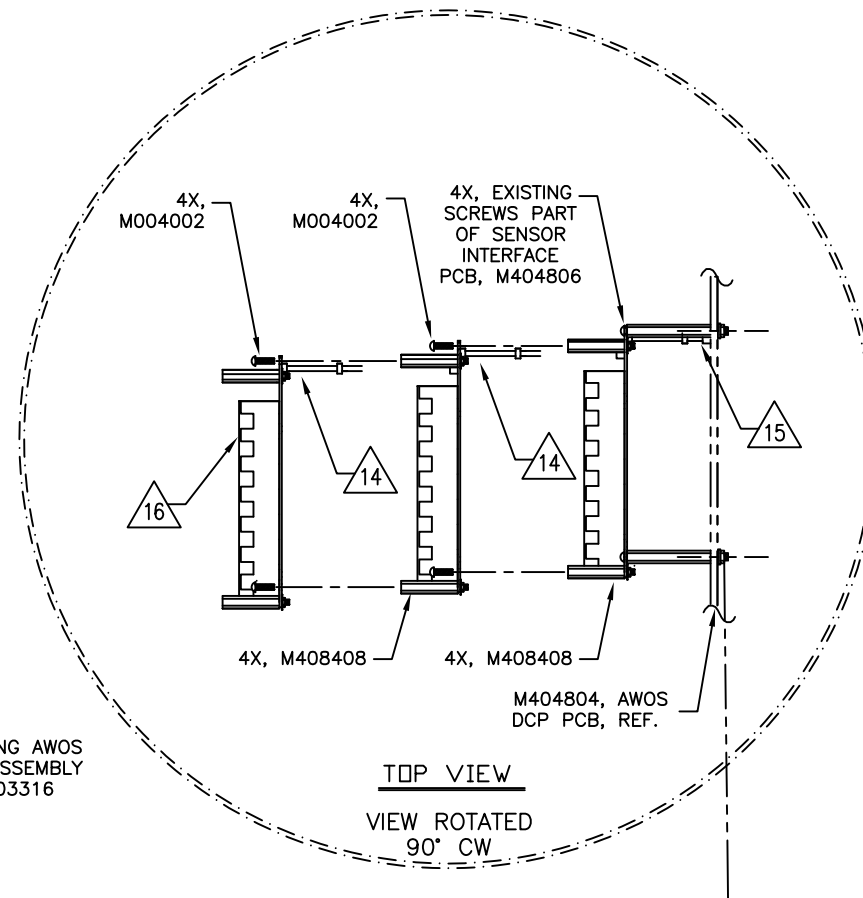

SERIAL SENSOR
INTERFACE KIT
M404806

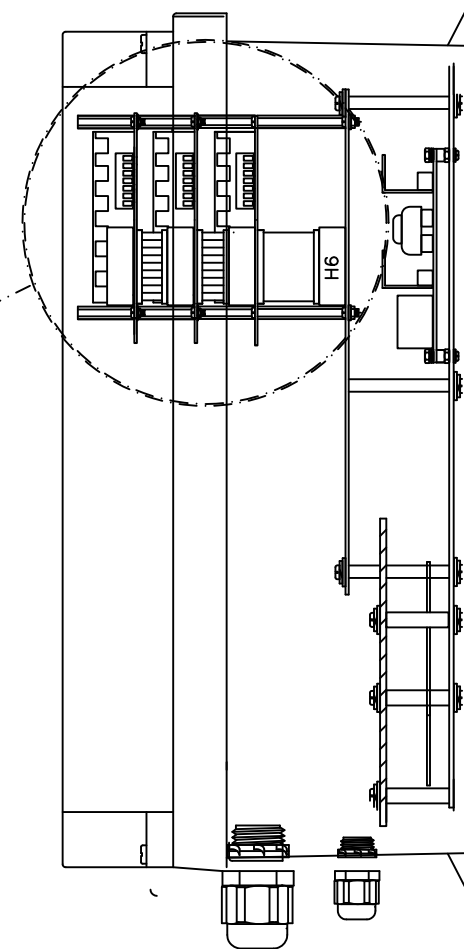

ENCLOSURE SIDE VIEW SECTION

EXCEPT AS MAY OTHERWISE BE SPECIFIED BY CONTRACT, THIS DOCUMENT AND THE DATA DISCLOSED HEREIN AND HERewith, IS NOT TO BE USED, REPRODUCED OR DISCLOSED, IN WHOLE OR IN PART, TO ANYONE WITHOUT THE WRITTEN PERMISSION OF ALL WEATHER, INC..

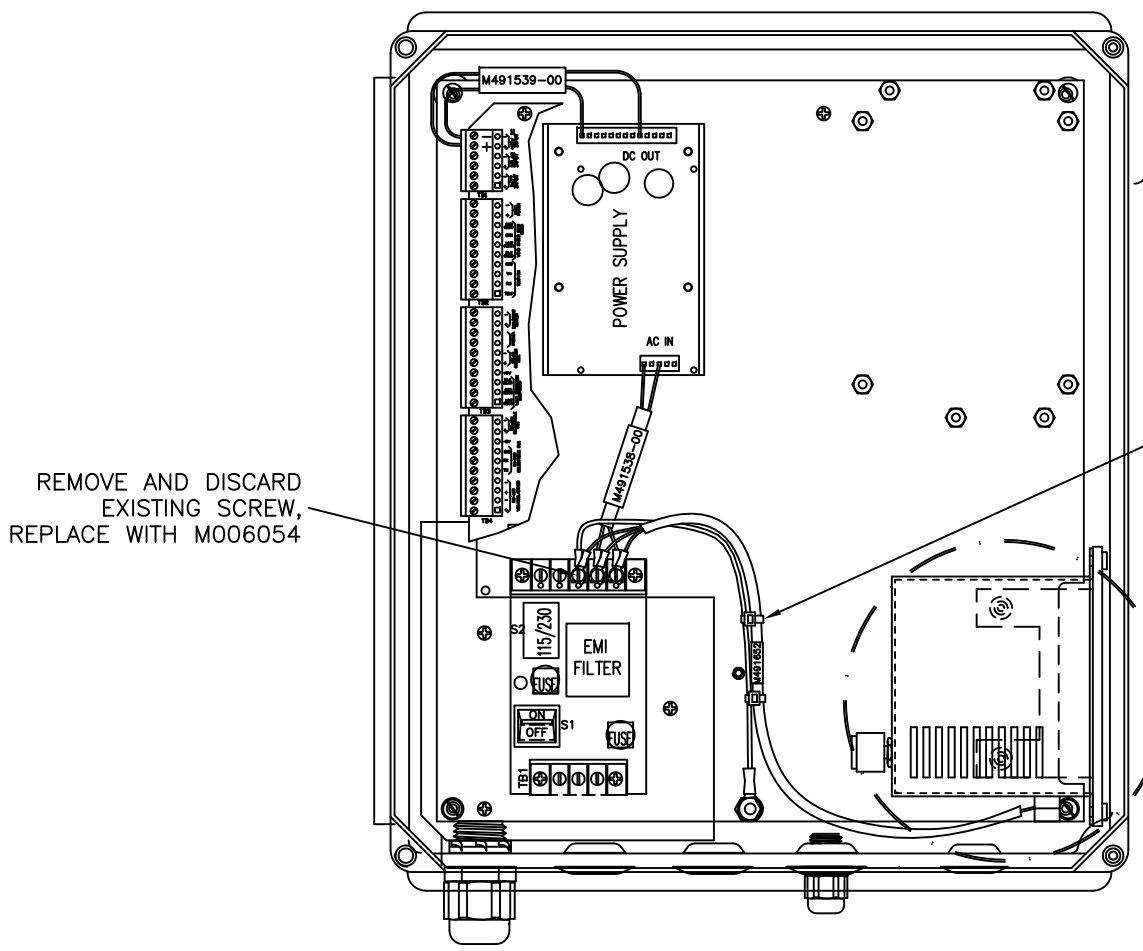

REMOVE AND DISCARD EXISTING SCREW, REPLACE WITH M006054

2X, M434001

ENCLOSURE LID AND PCB's REMOVED FOR CLARITY

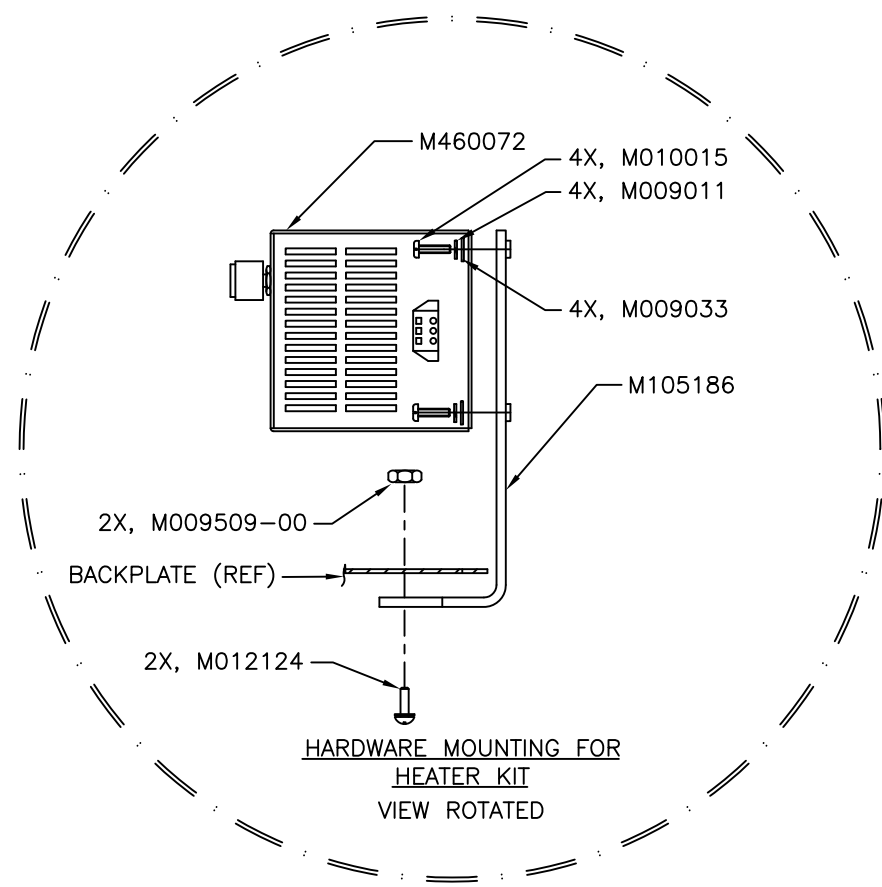

2X, M009509-00

BACKPLATE (REF)

2X, M012124

HARDWARE MOUNTING FOR HEATER KIT
VIEW ROTATED

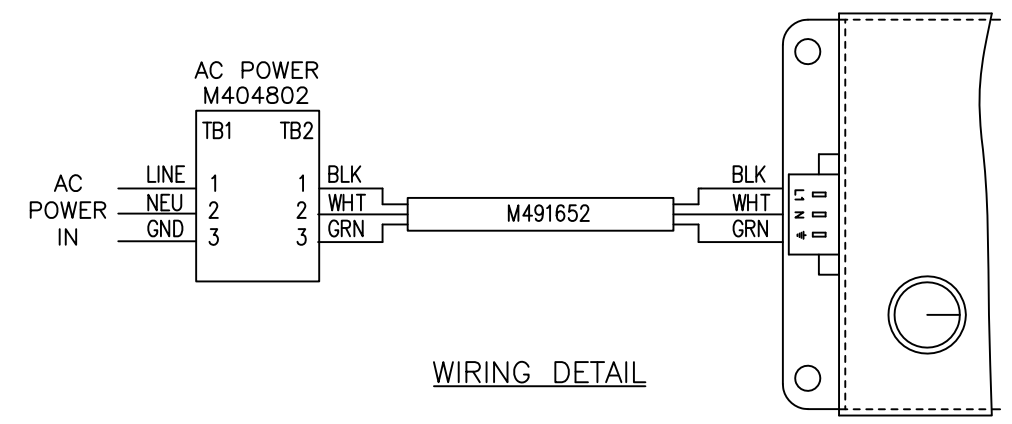

WIRING DETAIL

M488181
OPTIONAL HEATER KIT

EXCEPT AS MAY OTHERWISE BE SPECIFIED BY CONTRACT, THIS DOCUMENT AND THE DATA DISCLOSED HEREIN AND HEREWITH, IS NOT TO BE USED, REPRODUCED OR DISCLOSED, IN WHOLE OR IN PART, TO ANYONE WITHOUT THE WRITTEN PERMISSION OF ALL WEATHER, INC.

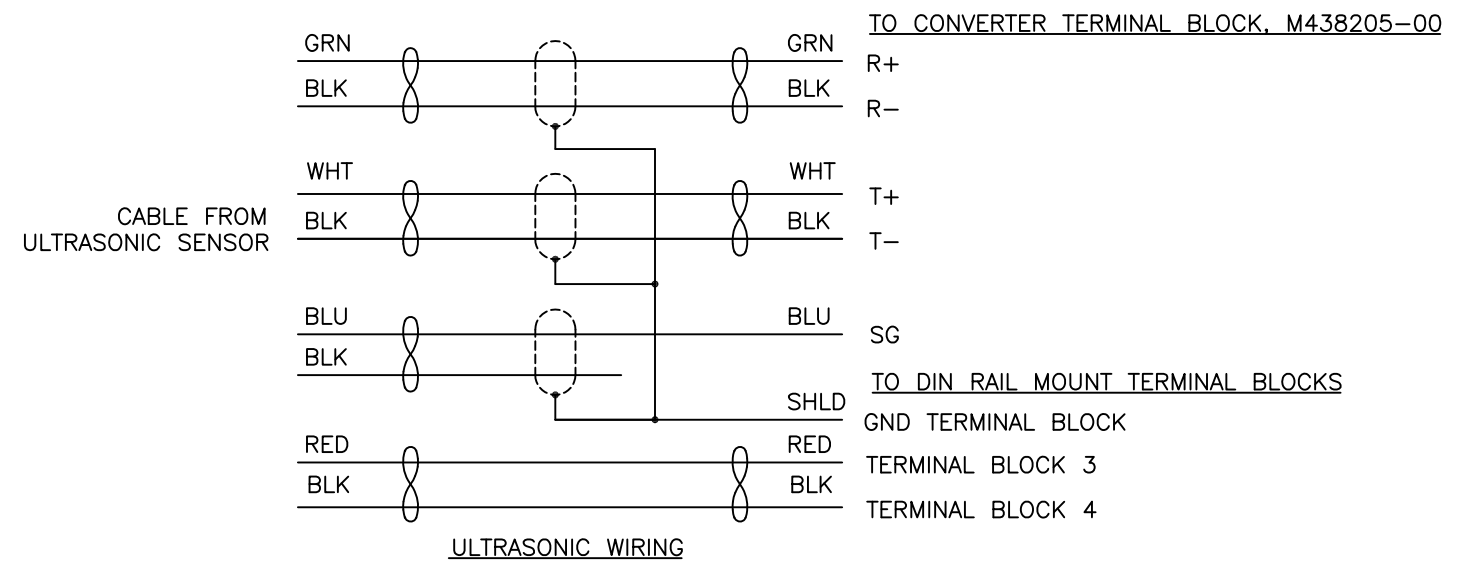
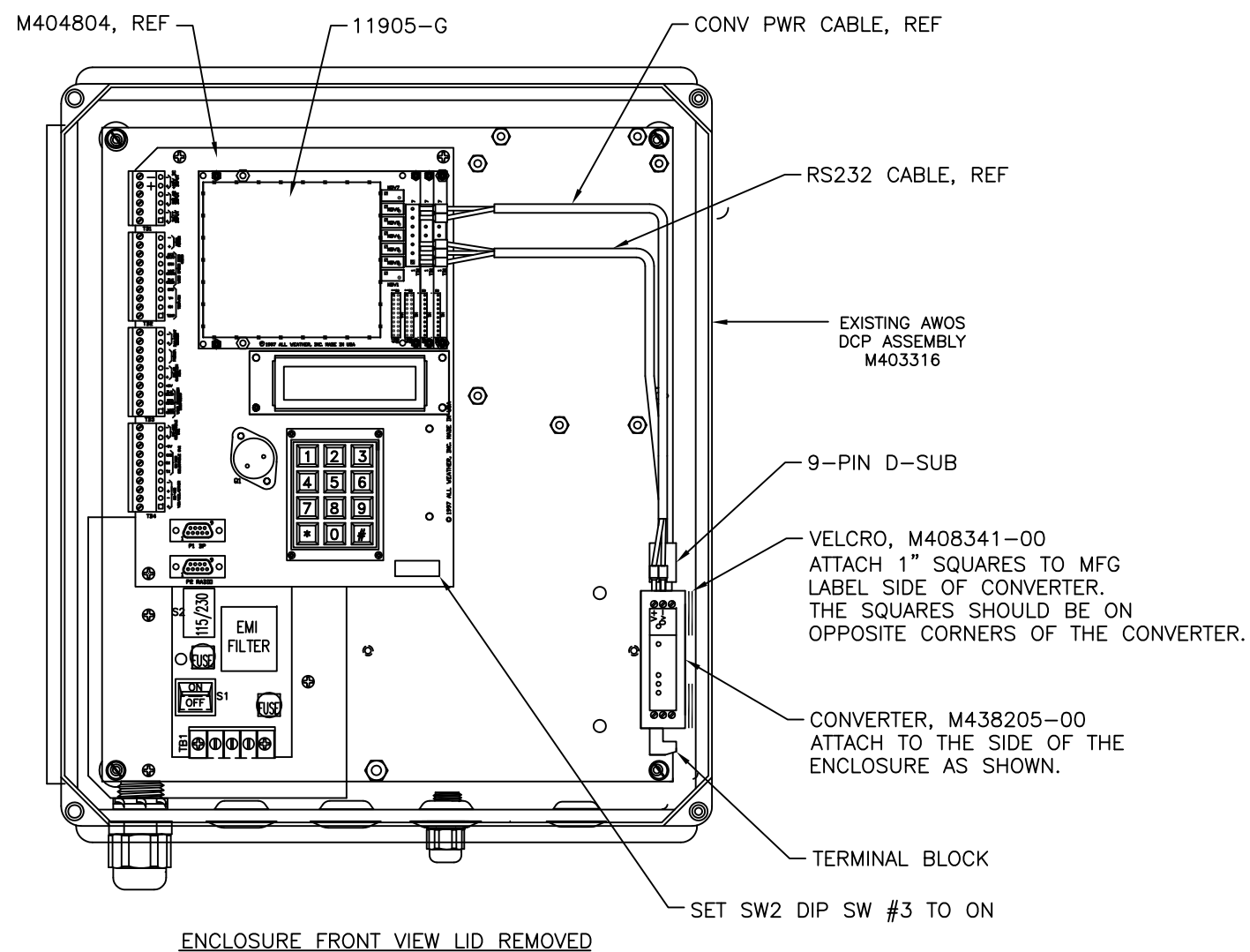
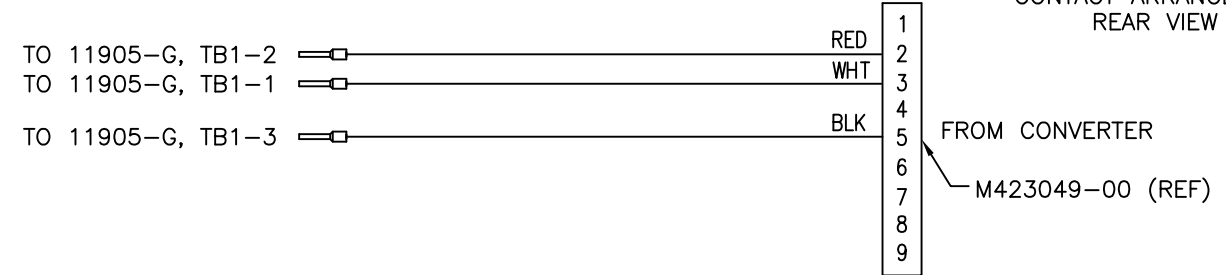
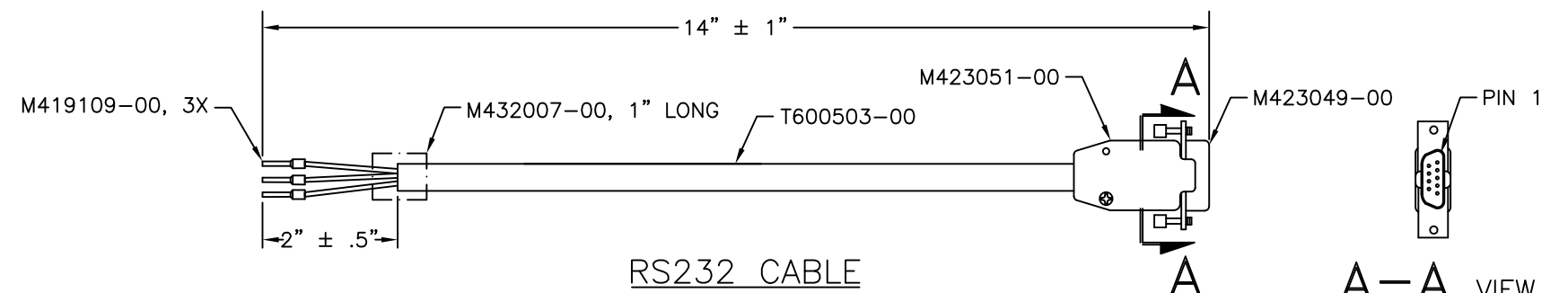
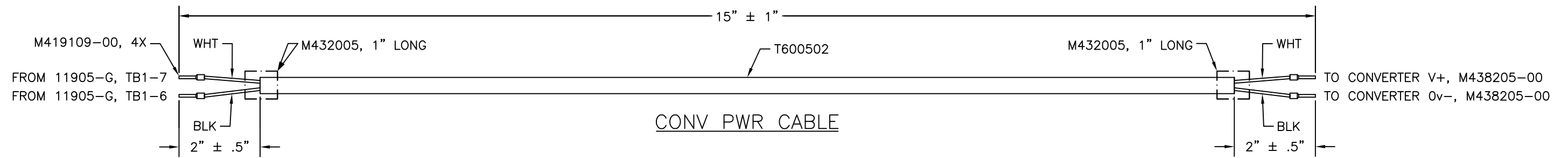

ULTRASONIC DCP INTERFACE KIT
M488271-00

EXCEPT AS MAY OTHERWISE BE SPECIFIED BY CONTRACT, THIS DOCUMENT AND THE DATA DISCLOSED HEREIN AND HERewith, IS NOT TO BE USED, REPRODUCED OR DISCLOSED, IN WHOLE OR IN PART, TO ANYONE WITHOUT THE WRITTEN PERMISSION OF ALL WEATHER, INC..

REVISIONS				
REV	ECN	DESCRIPTION	DATE	APPROVED
A	4703	INITIAL RELEASE	21OCT97	PK
B	4769	CHG CBL M491539 FROM: PIN 2 TO: PIN 4	2-23-98	CSP
C	4785	TB1 WAS TB4, REVERSE POSITION OF P1 & P2	4/22/98	CSP
D	4826	REPLACE 20980 RADIO WITH NEW 20980-A RADIO	10/25/99	CSP
E	4889	ADD HEATER KIT	3/23/01	C.P.
F	0832	ADDED 11902-B	6/7/06	BRG
G	0868	REPLACE DCP PWR SUPPLY W/MORE RELIABLE VERSION	1-17-07	PK

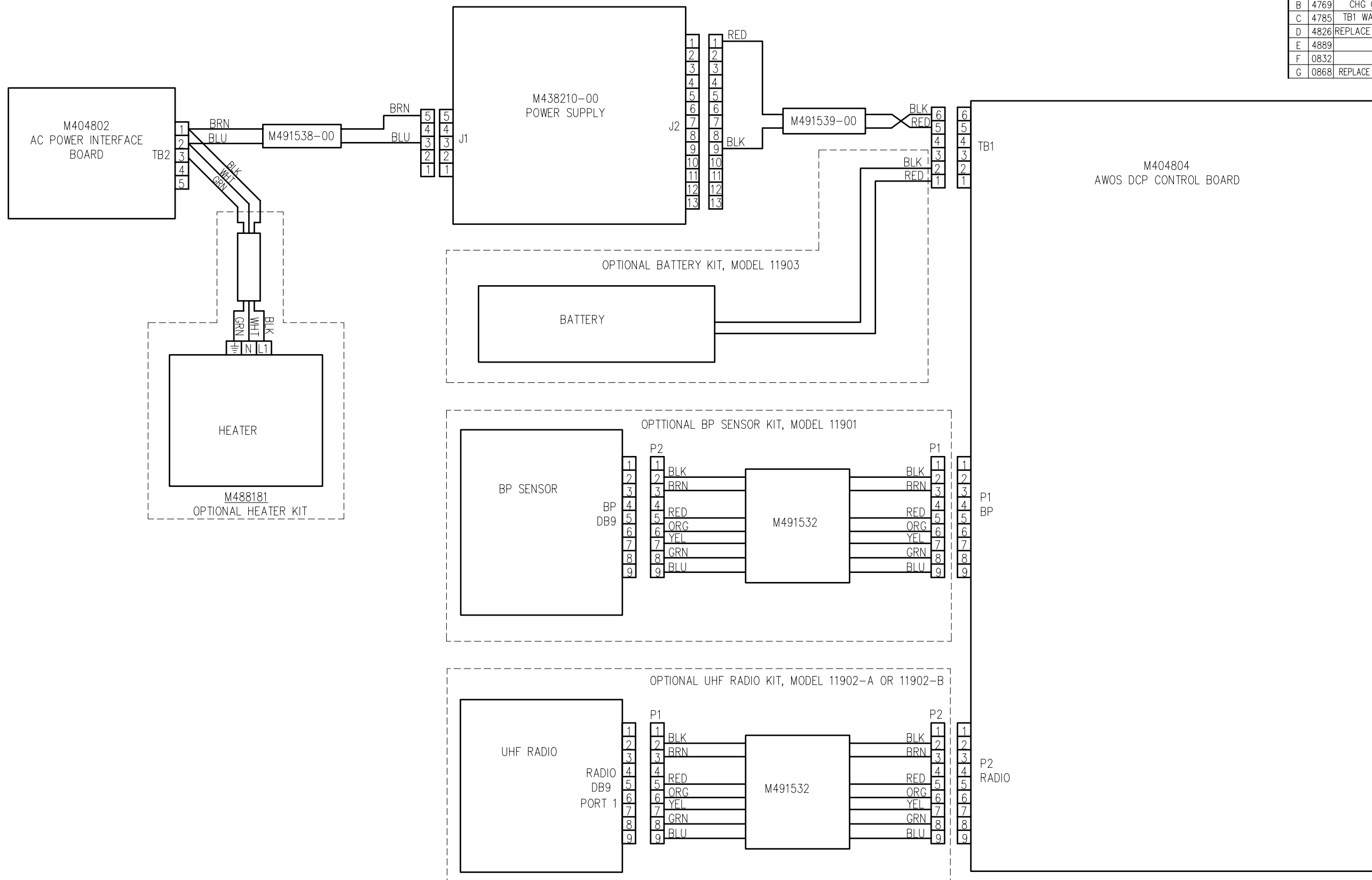

EXCEPT AS MAY OTHERWISE BE SPECIFIED BY CONTRACT, THIS DOCUMENT AND THE DATA DISCLOSED HEREIN AND HERewith, IS NOT TO BE USED, REPRODUCED OR DISCLOSED, IN WHOLE OR IN PART, TO ANYONE WITHOUT THE WRITTEN PERMISSION OF ALL WEATHER, INC..

APPEND THE FOLLOWING DOCUMENTS WHEN CHANGING THIS DOCUMENT:		UNLESS OTHERWISE SPECIFIED: DIMENSIONS ARE IN INCHES TOLERANCES .XX=±.010 ANGLES ±1/2" .XXX=±.005 CONCENTRICITY: .003 TIR DO NOT SCALE DRAWING		DRAWN BY: J.CONNER 10-3-97		TITLE WIRING DIAGRAM, AWOS DCP		
		MATERIAL SEE BILL OF MATERIALS		REVISED BY: Chander Palhan 17Nov00				
		FINISH AS ISSUED		CHECKED BY: Billy Galarpe 3-22-01				SIZE D
		TREATMENT NONE		DESIGN ENGINEER: J.CONNER 10-21-97		DWG NO. M403316-019		
		APPROVALS		PROJECT MANAGER: JJ SPOTTS 10-21-97		SCALE NONE RELEASE DATE 10-21-97 SHEET 1 OF 1		

NOTES: UNLESS OTHERWISE SPECIFIED;

1. WHEN USING MODEL 8518-A FOLDOVER TOWER, MOUNT TO HINGED SIDE OF TOWER.

REVISIONS			DWG NO. 1190-007	
REV	ECN	DESCRIPTION	DATE	APPROVED
A	4769	INITIAL RELEASE	2/23/98	CSP
B	4981	ADD NOTE FOR FOLD OVER TOWER MOUNTING		
C	1400	UPDATE DWG FOR CORROSION RESISTANT MTG KIT	9/2/08	BRG
D	1938	UPDATE DCP BOX	03/24/10	TI

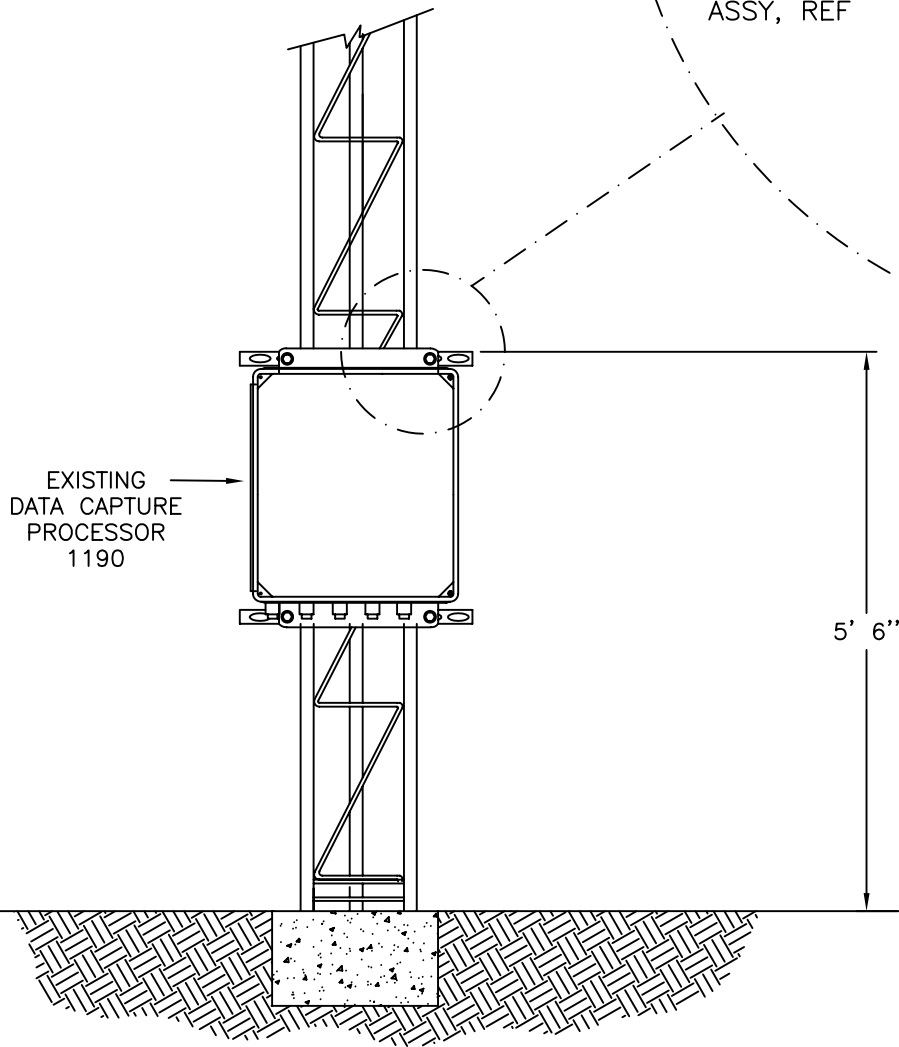
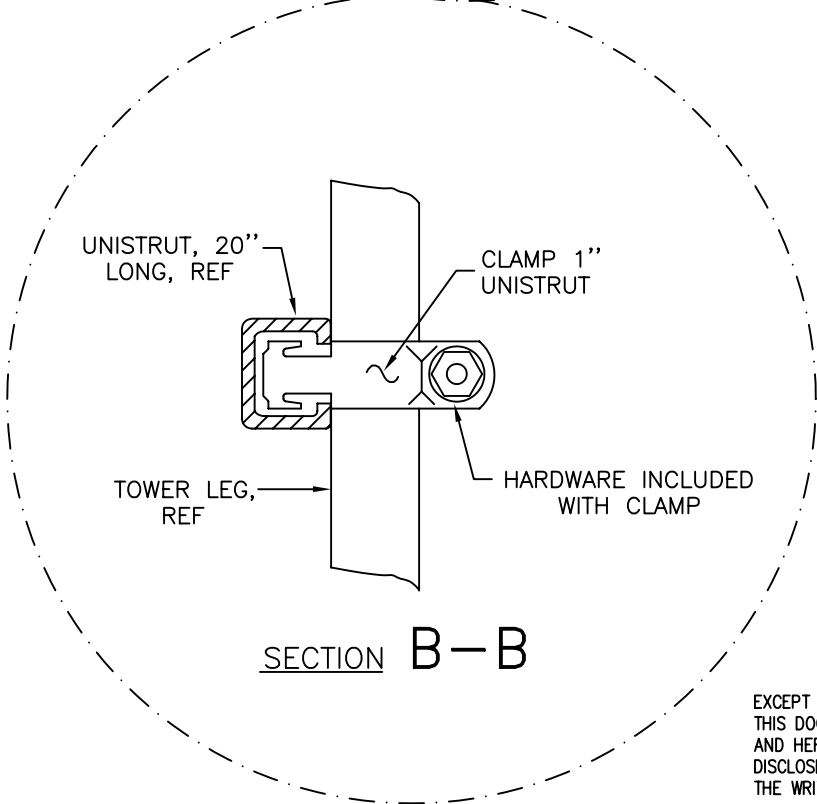
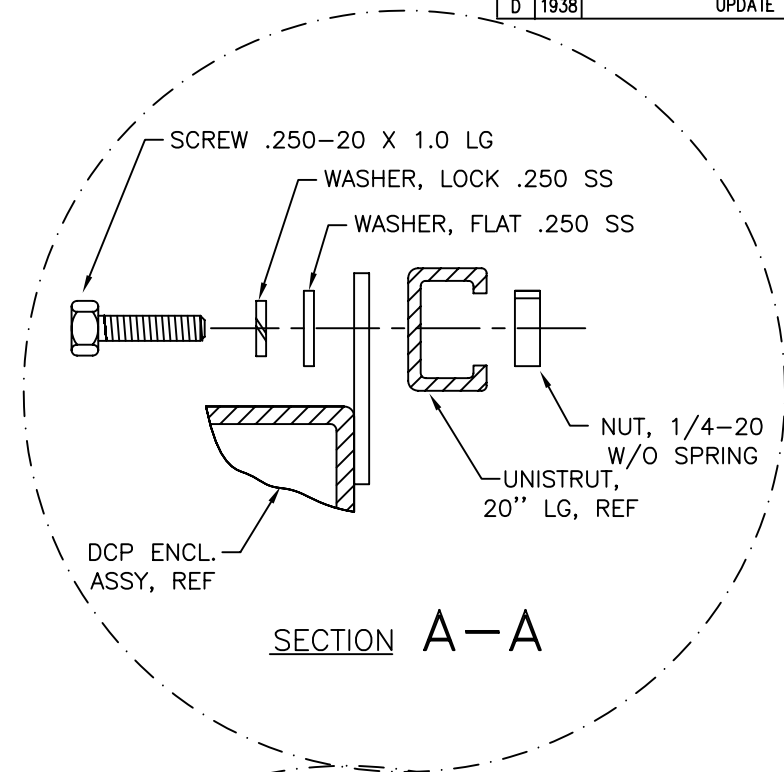
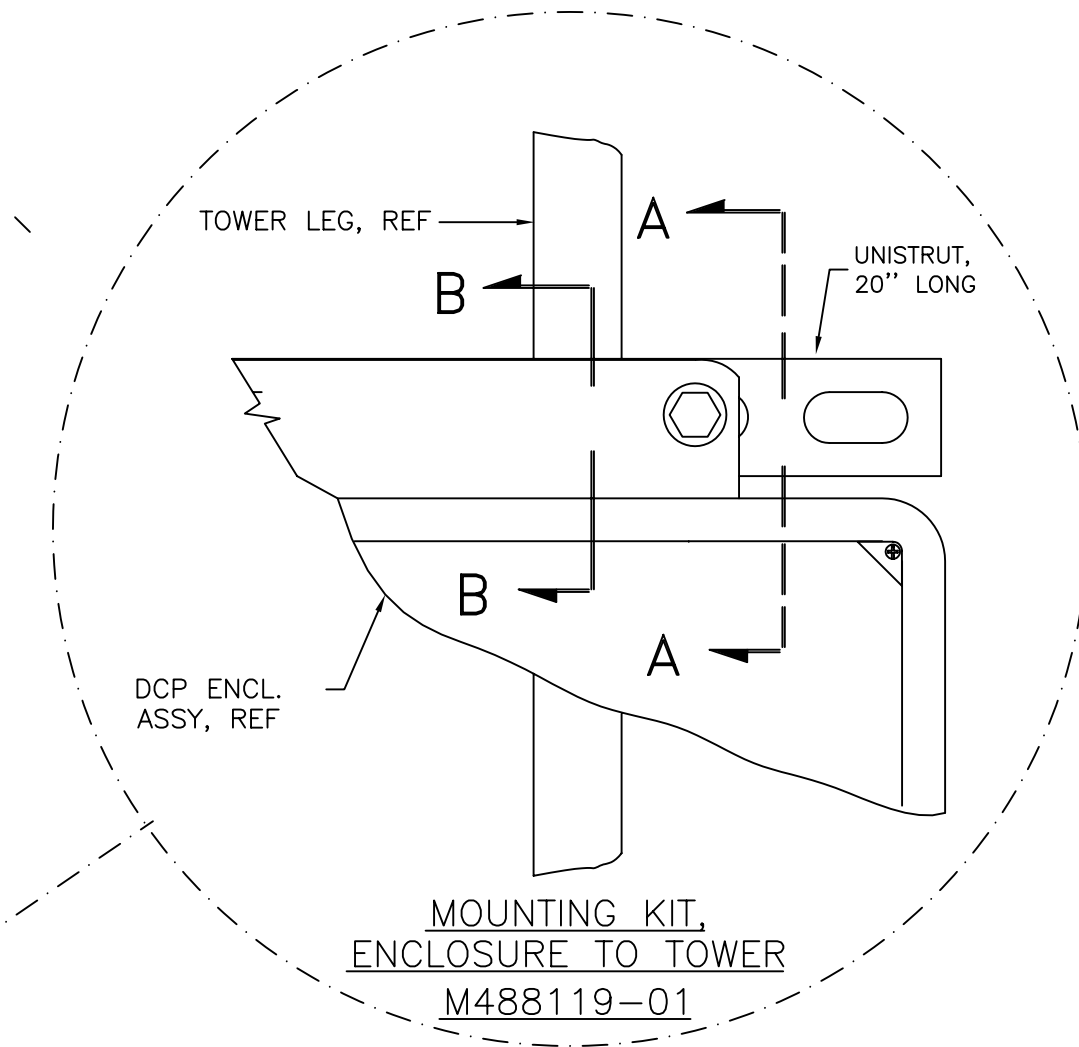

MOUNTING KIT,
ENCLOSURE TO TOWER
M488119-01

EXCEPT AS MAY OTHERWISE BE SPECIFIED BY CONTRACT, THIS DOCUMENT AND THE DATA DISCLOSED HEREIN AND HERewith, IS NOT TO BE USED, REPRODUCED OR DISCLOSED, IN WHOLE OR IN PART, TO ANYONE WITHOUT THE WRITTEN PERMISSION OF ALL WEATHER INC.

APPEND THE FOLLOWING DOCUMENTS WHEN CHANGING THIS DOCUMENT:		UNLESS OTHERWISE SPECIFIED: DIMENSIONS ARE IN INCHES TOLERANCES XX=±.010 ANGLES ±1/2° XXX=±.005 CONCENTRICITY: .003 TIR DO NOT SCALE DRAWING		DRAWN BY: P Kooyman 10FEB98		TITLE INSTALLATION DRAWING, 1190 DCP TOWER MOUNTING		
		MATERIAL: SEE BILL OF MATERIALS		REVISED BY: T IWANOWSKI 03/24/10		DWG NO. 1190-007		
		FINISH: AS ISSUED		CHECKED BY:		SIZE D		SHEET 1 OF 1
		TREATMENT		DESIGN ENGINEER:		SCALE NONE		
				PROJECT MANAGER:		RELEASE DATE		
				APPROVALS		DATE		

REVISIONS			DWG NO. M404802-003	
REV	ECN	DESCRIPTION	DATE	APPROVED
A	4680	INITIAL RELEASE		
B	5104	ADDED NOTE 7 TO HAND SOLDER S1	1-17-05	B.R.G.

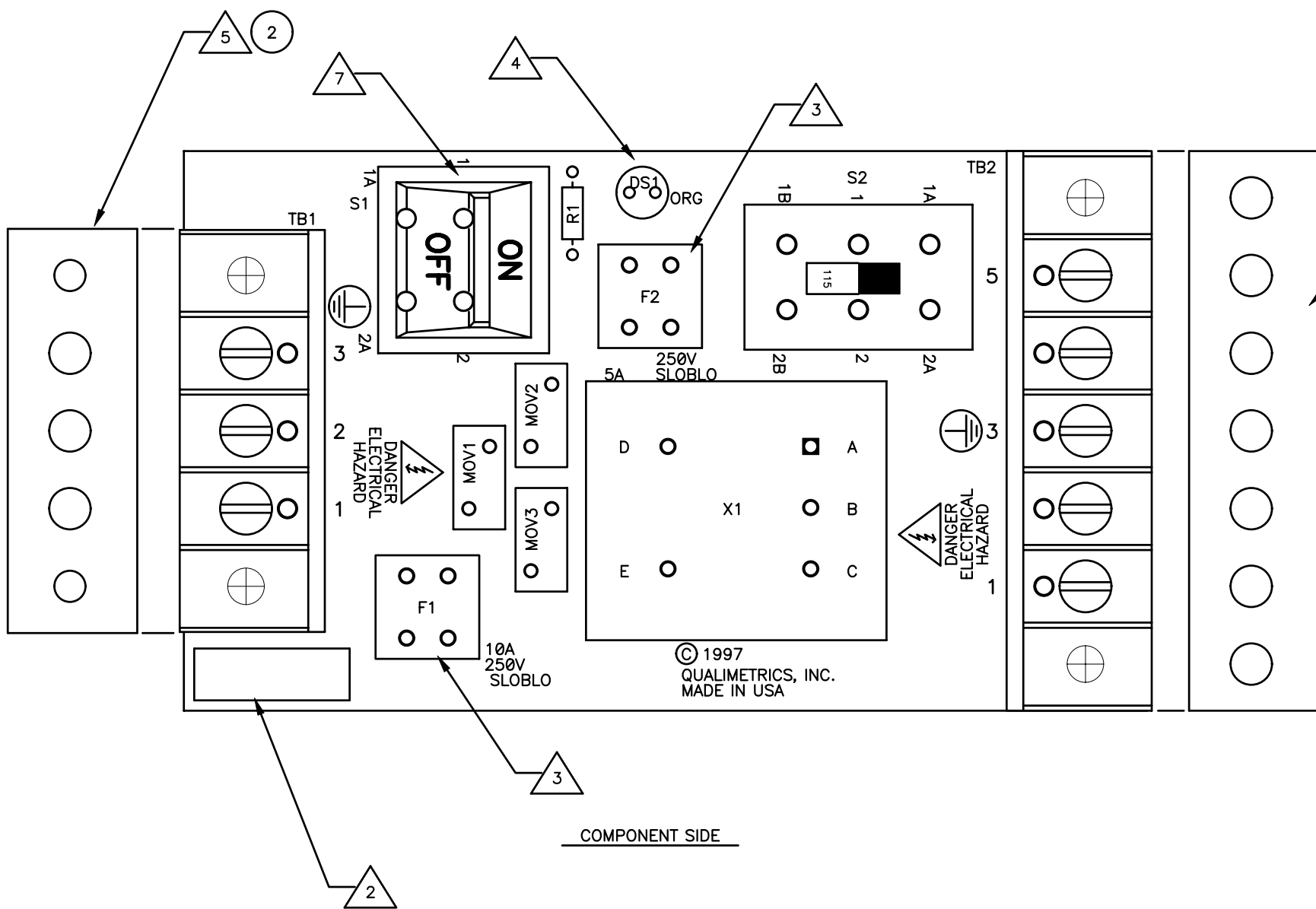

- NOTES: UNLESS OTHERWISE SPECIFIED:
- TRIM ALL COMPONENT LEADS IN COMPLIANCE WITH QUALIMETRICS WORKMANSHIP MANUAL.
 - ENSURE PCB ASSEMBLY IS CORRECTLY LABELED IN COMPLIANCE WITH QAI228.
 - INSTALL XF1 AND XF2 PRIOR TO INSTALLATION OF F1 AND F2.
 - INSTALL IT-1 PRIOR TO INSTALLATION OF DS1. (NOT INSTALLED ON THIS ASSEMBLY)
 - PRESS-FIT IT-2 ONTO TB1 AFTER INSTALLATION.
 - PRESS-FIT IT-3 ONTO TB2 AFTER INSTALLATION.
 - S1 MUST BE HAND SOLDERED TO PREVENT CONTAMINATION. DO NOT WAVE SOLDER.

EXCEPT AS MAY OTHERWISE BE SPECIFIED BY CONTRACT, THIS DOCUMENT AND THE DATA DISCLOSED HEREIN AND HEREWITH, IS NOT TO BE USED, REPRODUCED OR DISCLOSED, IN WHOLE OR IN PART, TO ANYONE WITHOUT THE WRITTEN PERMISSION OF ALL WEATHER, INC..

APPEND THE FOLLOWING DOCUMENTS WHEN CHANGING THIS DOCUMENT:		REFERENCE DOCUMENTS		UNLESS OTHERWISE SPECIFIED: DIMENSIONS ARE IN INCHES		DRAWN BY: KEITH HOEK		DATE: 03APR97		TITLE: PCB ASSEMBLY 7.5/3.75 AMP, A/C POWER INTERFACE 115/230 VOLT		allweatherinc	
		A/W	M405570-011	TOLERANCES XX= +/- .010 ANGL= +/- 1/2 DEGREE XXX= +/- .005 FRACTIONS= +/- .02 DO NOT SCALE DRAWING		REVISED BY:				SIZE: C		DWG NO. M404802-003	
		FAB	M405570-012	MATERIAL: SEE BILL OF MATERIALS		CHECKED BY:				SCALE: 2 : 1		SHEET: 1 OF 1	
		SCH	M404802-004	FINISH: AS ISSUED		DESIGN ENGINEER: MICHAEL HOOVER		DATE: 5-9-97		RELEASE DATE:			
		ETS	M404802-021	TREATMENT:		PROJECT MANAGER:				APPROVALS:			

REV		REVISIONS		DWG NO. M404802-004	
A	4680	DESCRIPTION		DATE	APPROVED
		INITIAL RELEASE			

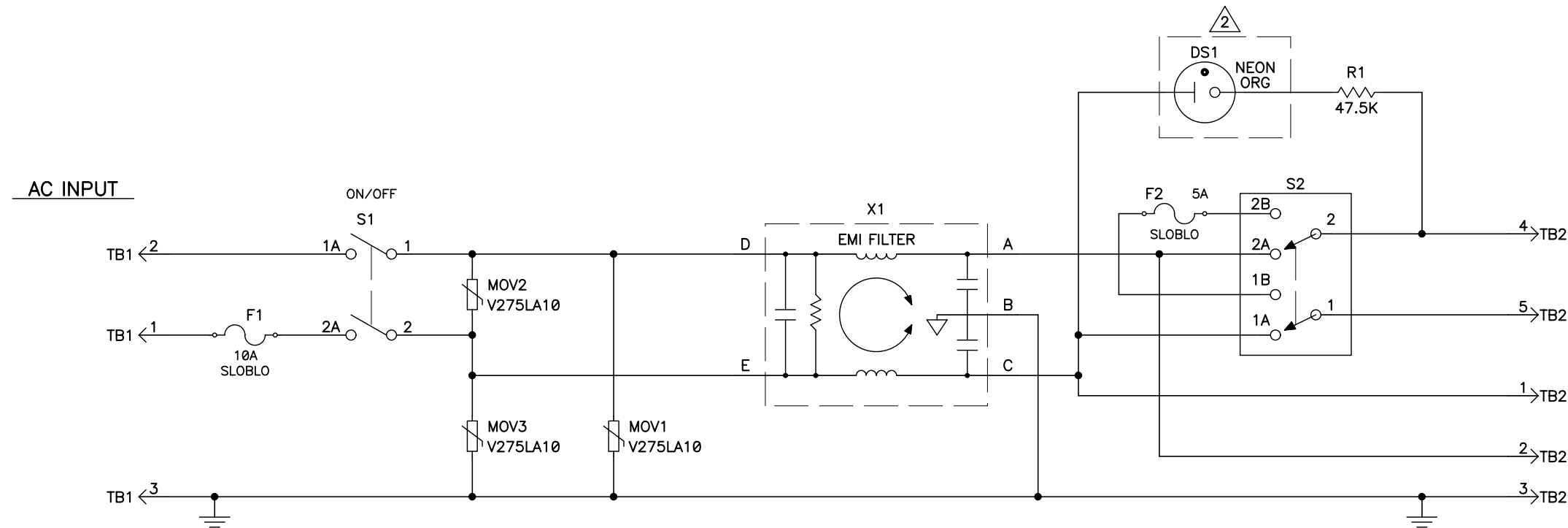

NOTES: UNLESS OTHERWISE SPECIFIED

1. ALL RESISTANCE IS IN OHMS, 1/4W, 1%.

② DS1 NOT INSTALLED ON M404802 ASSEMBLY.

EXCEPT AS MAY OTHERWISE BE SPECIFIED BY CONTRACT,
THIS DOCUMENT AND THE DATA DISCLOSED HEREIN
AND HEREWITH, IS NOT TO BE USED, REPRODUCED OR
DISCLOSED, IN WHOLE OR IN PART, TO ANYONE WITHOUT
THE WRITTEN PERMISSION OF ALL WEATHER, INC..

APPEND THE FOLLOWING DOCUMENTS WHEN CHANGING THIS DOCUMENT:	REFERENCE DOCUMENTS	REFERENCE DESIGNATIONS		DRAWN BY:	03APR97	TITLE SCHEMATIC DIAGRAM 7.5/3.75 AMP, A/C POWER INTERFACE 115/230 VOLT	
	A/W M405570-001 FAB M405570-012 ASSY M404802-003 ETS M404802-021	LAST USED	NOT USED	KEITH HOEK	03APR97		
				REVISED BY:		SIZE C DWG NO. M404802-004	
				CHECKED BY:			
				DESIGN ENGINEER:	5-9-97	SCALE NONE RELEASE DATE SHEET 1 OF 1	
				PROJECT MANAGER:			
				APPROVALS	DATE		

REVISIONS				DWG NO.
REV	ECO	DESCRIPTION	DATE	APPROVED
A	0866	INITIAL RELEASE	7-27-06	PK
B	0860	CHANGE GROUND WIRING COLORS OF 5190-D	9-26-06	PK
C	0909	ADD(T600503-3rd RED WIRE)CONNECT FOR RS485	10-30-06	PK
D	0868	REPLACE DCP PWR SUPPLY W/MORE RELIABLE VERSION	2-16-07	PK
E	1346	SWAPPED 6495 RED & WHT WIRING TO 1190 INTERFACE	1-08-08	PK
F	1377	CHG RAIN GAUGE CABLE M491238 TO 60116	1-17-08	BRG
G	1888	5190-F UPDATE	04-15-10	SLVS

DWG NO. 903-E-019

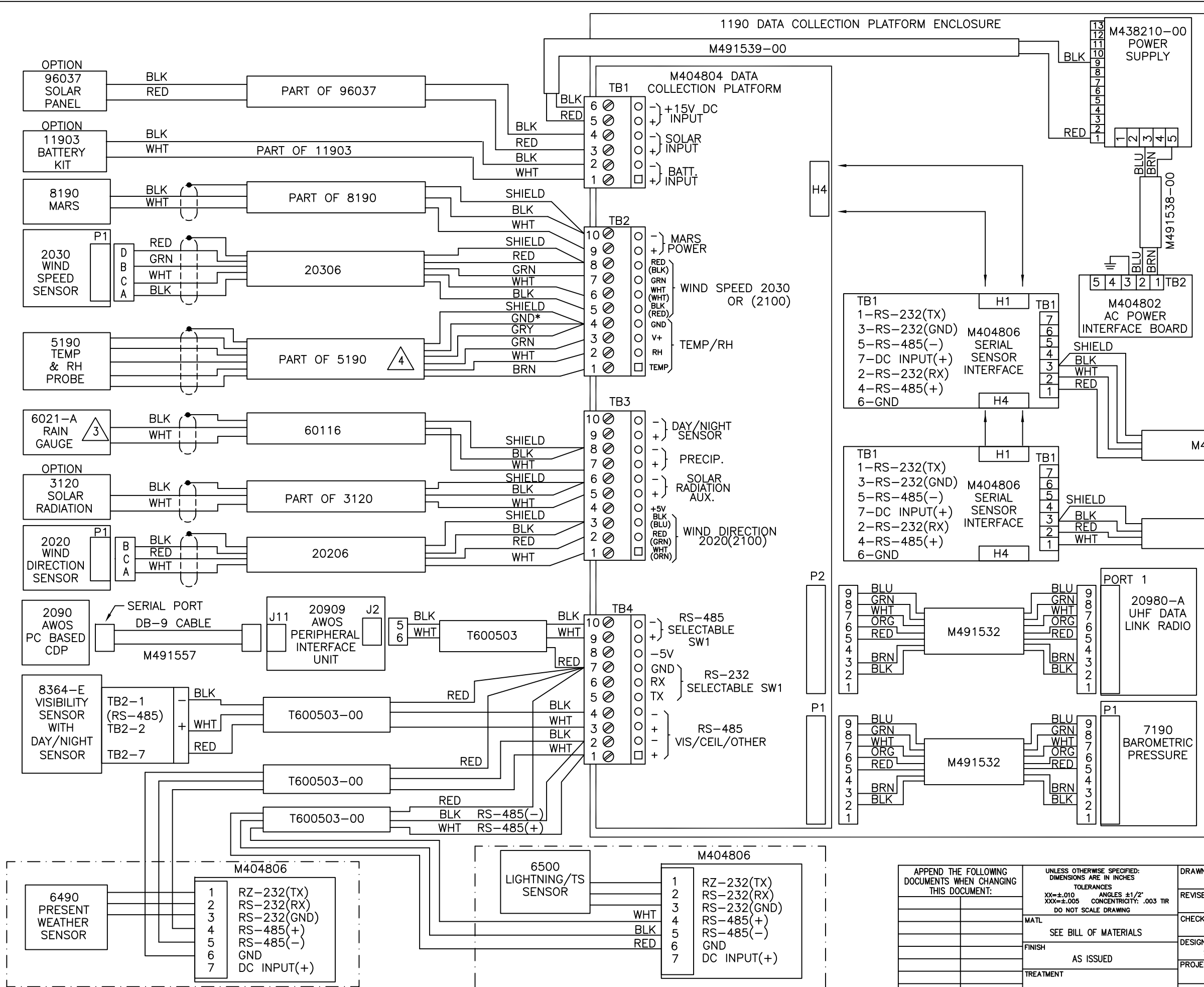

- NOTES: UNLESS OTHERWISE SPECIFIED;
- AWOS I (AWI MODEL 901-A, 901-B) DOES NOT INCLUDE 8364 VISIBILITY SENSOR, 83339-A DAY/NIGHT SENSOR, 8329-A CLOUD HEIGHT SENSOR OR 6021-A RAIN GAUGE.
 - AWOS II (AWI MODEL 902-A, 902-B) DOES NOT INCLUDE 8329-A CLOUD HEIGHT SENSOR.
- 3 IN AREAS NOT REQUIRING A HEATED RAIN GAUGE, THE 6011-A RAIN GAUGE MAY BE USED IN LIEU OF THE 6021-A RAIN GAUGE WITH FAA APPROVAL BY A WAIVER.
- 4 5190-D GND* IS BLUE. 5190-F GND* IS YELLOW.

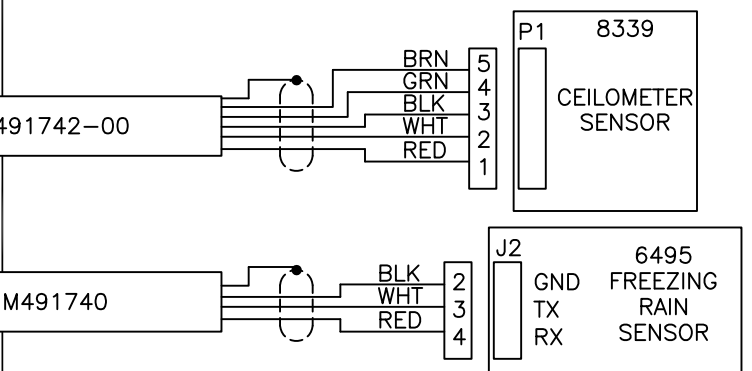

EXCEPT AS MAY OTHERWISE BE SPECIFIED BY CONTRACT, THIS DOCUMENT AND THE DATA DISCLOSED HEREIN AND HERewith, IS NOT TO BE USED, REPRODUCED OR DISCLOSED, IN WHOLE OR IN PART, TO ANYONE WITHOUT THE WRITTEN PERMISSION OF ALL WEATHER INC.

APPEND THE FOLLOWING DOCUMENTS WHEN CHANGING THIS DOCUMENT:		UNLESS OTHERWISE SPECIFIED: DIMENSIONS ARE IN INCHES TOLERANCES XX=±.010 ANGLES ±1/2° XXX=±.005 CONCENTRICITY: .003 TIR DO NOT SCALE DRAWING		DRAWN BY: P KOOYMAN 7-27-06		TITLE WIRING DIAGRAM AWOS 903-E WITH 2020/2030, 8339 AND 8364-E VIS SENSOR	
		MATERIAL SEE BILL OF MATERIALS		REVISED BY: P KOOYMAN 9-26-06		allweatherinc	
		FINISH AS ISSUED		CHECKED BY:		SIZE D DWG NO. 903-E-019	
		TREATMENT		DESIGN ENGINEER: SLVS 7-27-06		SCALE NONE	
				PROJECT MANAGER:		RELEASE DATE	
				APPROVALS		SHEET 1 OF 1	

REV		ECO	DESCRIPTION	DATE	APPROVED
A	1745		INITIAL RELEASE	1-29-09	J.CONNER
B	1459		ADDED M491887-00, UHF PWR TAP, GILL DC PWR CABLE	9/10/09	BRG
C	1888		5190-F UPDATE	04/15/10	SLVS

NOTES: UNLESS OTHERWISE SPECIFIED;

1. AWOS I (AWI MODEL 901-A, 901-B) DOES NOT INCLUDE 8364 VISIBILITY SENSOR, 83339-A DAY/NIGHT SENSOR, 8329-A CLOUD HEIGHT SENSOR, OR 6021-A RAIN GAUGE.

2. AWOS II (AWI MODEL 902-A, 902-B) DOES NOT INCLUDE 8329-A CLOUD HEIGHT SENSOR.

3. IN AREAS NOT REQUIRING A HEATED RAIN GAUGE, THE 6011-A RAIN GAUGE MAY BE USED IN LIEU OF THE 6021-A RAIN GAUGE WITH FAA APPROVAL BY A WAIVER.

4. 5190-D GND* IS BLUE.
5190-F GND* IS YELLOW.

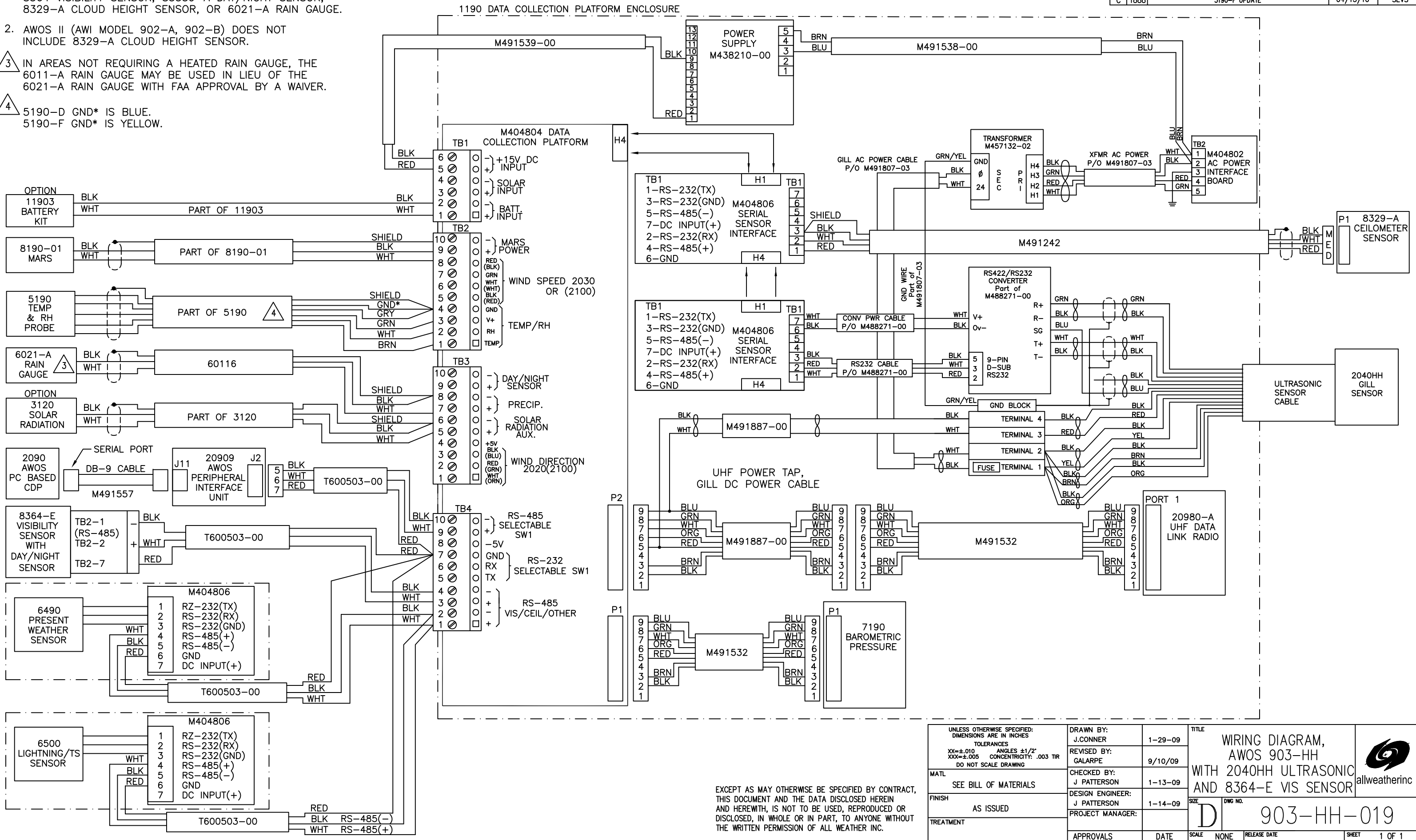

EXCEPT AS MAY OTHERWISE BE SPECIFIED BY CONTRACT, THIS DOCUMENT AND THE DATA DISCLOSED HEREIN AND HERewith, IS NOT TO BE USED, REPRODUCED OR DISCLOSED, IN WHOLE OR IN PART, TO ANYONE WITHOUT THE WRITTEN PERMISSION OF ALL WEATHER INC.

UNLESS OTHERWISE SPECIFIED: DIMENSIONS ARE IN INCHES TOLERANCES XX=±.010 ANGLES ±1/2° XXX=±.005 CONCENTRICITY: .003 TIR DO NOT SCALE DRAWING		DRAWN BY: J.CONNER 1-29-09	TITLE WIRING DIAGRAM, AWOS 903-HH WITH 2040HH ULTRASONIC AND 8364-E VIS SENSOR	
MATL SEE BILL OF MATERIALS	REVISED BY: GALARPE 9/10/09	CHECKED BY: J PATTERSON 1-13-09	SIZE D	
FINISH AS ISSUED	DESIGN ENGINEER: J PATTERSON 1-14-09	PROJECT MANAGER:	DWG NO. 903-HH-019	SHEET 1 OF 1
TREATMENT	APPROVALS	DATE	SCALE NONE RELEASE DATE	

REV	ECO	DESCRIPTION	DATE	APPROVED
A	1535	INITIAL RELEASE	11-16-09	JPATTERSON
B	1888	5190-F UPDATE	04-15-10	SVANSANTEN

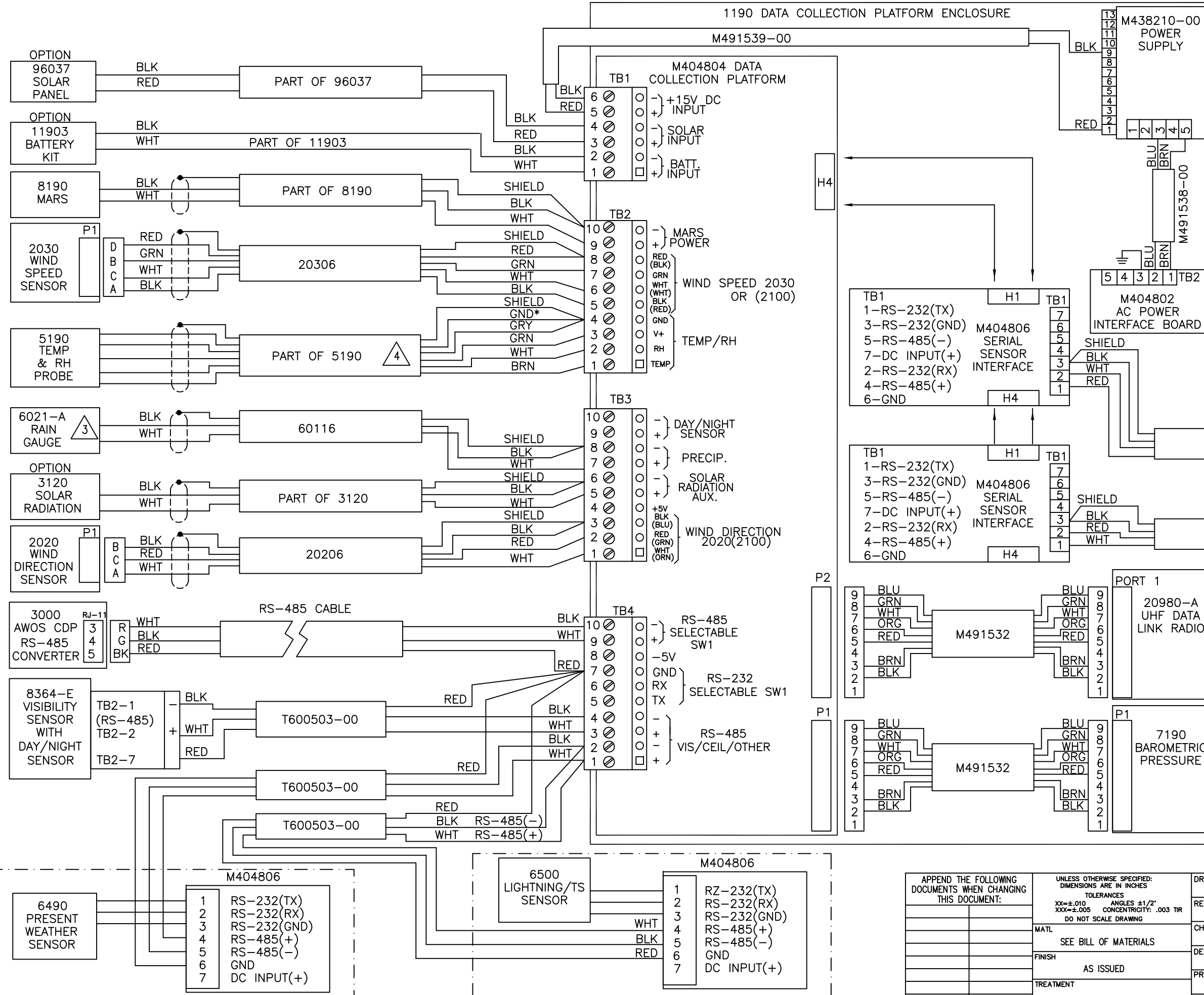

- NOTES: UNLESS OTHERWISE SPECIFIED;
- DRAWING SHOWS ALL POSSIBLE SENSORS (OTHER THAN ULTRASONIC WINDS) THAT CAN BE CONNECTED TO THE DCP FOR AN AWOS. SOME SENSORS MAY NOT BE PART OF SYSTEM CONFIGURATION. REFER TO THE CONFIGURATION MATRIX FOR ACTUAL SENSORS INSTALLED.
 - IF A RAIN GAUGE IS INSTALLED WITH THE PRESENT WEATHER SENSOR (6490), THE RAIN GAUGE IS USED TO MEASURE RAIN ACCUMULATION.
- △ 3 IN AREAS NOT REQUIRING A HEATED RAIN GAUGE, THE 6011-A RAIN GAUGE MAY BE USED IN LIEU OF THE 6021-A RAIN GAUGE WITH FAA APPROVAL BY A WAIVER.

△ 4 5190-D GND* IS BLUE.
5190-F GND* IS YELLOW.

EXCEPT AS MAY OTHERWISE BE SPECIFIED BY CONTRACT, THIS DOCUMENT AND THE DATA DISCLOSED HEREIN AND HERewith, IS NOT TO BE USED, REPRODUCED OR DISCLOSED, IN WHOLE OR IN PART, TO ANYONE WITHOUT THE WRITTEN PERMISSION OF ALL WEATHER INC.

APPEND THE FOLLOWING DOCUMENTS WHEN CHANGING THIS DOCUMENT:	UNLESS OTHERWISE SPECIFIED: DIMENSIONS ARE IN INCHES TOLERANCES XX=±.010 ANGLES ±1/2' XXX=±.005 CONCENTRICITY: .003 TIR DO NOT SCALE DRAWING	DRAWN BY: J PATTERSON 11-16-09	TITLE WIRING DIAGRAM AWOS 3000 WITH 2020/2030 WIND SENSORS
	MATL SEE BILL OF MATERIALS	REVISD BY:	allweatherinc
	FINISH AS ISSUED	CHECKED BY:	
	TREATMENT	DESIGN ENGINEER: J PATTERSON 11-16-09	PROJECT MANAGER:
APPROVALS	DATE	SCALE NONE	RELEASE DATE
			SHEET 1 OF 1

REV	ECO	DESCRIPTION	DATE	APPROVED
A	1535	INITIAL RELEASE	11-16-09	JPATTERSON
B	1888	HUMIDITY 5190-F UPDATE	04-15-10	SVANSANTEN

NOTES: UNLESS OTHERWISE SPECIFIED;

1. DRAWING SHOWS ALL POSSIBLE SENSORS (OTHER THAN ULTRASONIC WINDS) THAT CAN BE CONNECTED TO THE DCP FOR AN AWOS. SOME SENSORS MAY NOT BE PART OF SYSTEM CONFIGURATION. REFER TO THE CONFIGURATION MATRIX FOR ACTUAL SENSORS INSTALLED.

2. IF A RAIN GAUGE IS INSTALLED WITH THE PRESENT WEATHER SENSOR (6490), THE RAIN GAUGE IS USED TO MEASURE RAIN ACCUMULATION.

3. IN AREAS NOT REQUIRING A HEATED RAIN GAUGE, THE 6011-A RAIN GAUGE MAY BE USED IN LIEU OF THE 6021-A RAIN GAUGE WITH FAA APPROVAL BY A WAIVER.

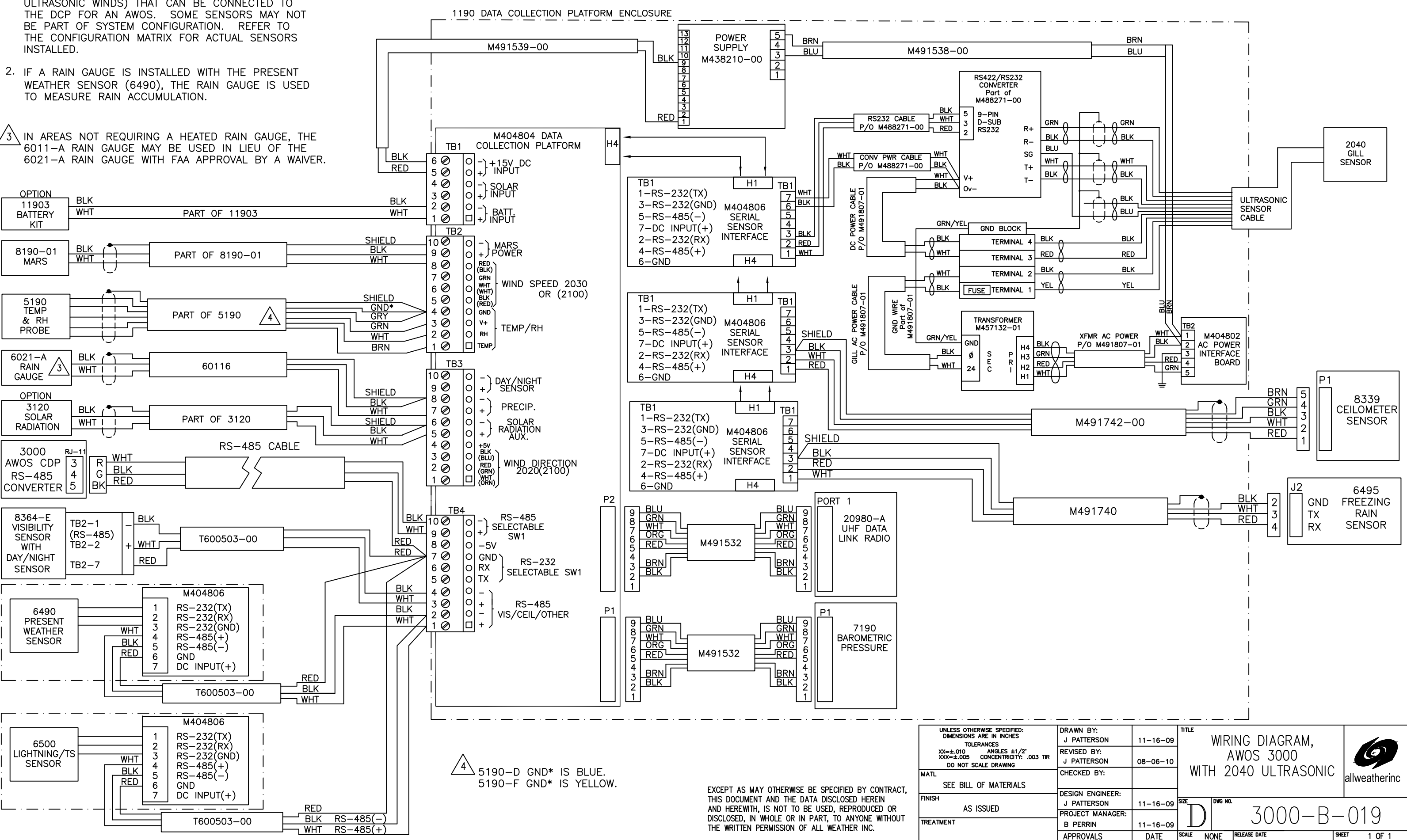

4. 5190-D GND* IS BLUE.
5190-F GND* IS YELLOW.

EXCEPT AS MAY OTHERWISE BE SPECIFIED BY CONTRACT, THIS DOCUMENT AND THE DATA DISCLOSED HEREIN AND HERewith, IS NOT TO BE USED, REPRODUCED OR DISCLOSED, IN WHOLE OR IN PART, TO ANYONE WITHOUT THE WRITTEN PERMISSION OF ALL WEATHER INC.

UNLESS OTHERWISE SPECIFIED: DIMENSIONS ARE IN INCHES TOLERANCES XX=±.010 ANGLES ±1/2° XXX=±.005 CONCENTRICITY: .003 TIR DO NOT SCALE DRAWING		DRAWN BY: J PATTERSON 11-16-09	TITLE WIRING DIAGRAM, AWOS 3000 WITH 2040 ULTRASONIC	
MATERIAL SEE BILL OF MATERIALS		REVISOR BY: J PATTERSON 08-06-10	DATE 11-16-09	
FINISH AS ISSUED		CHECKED BY:	DESIGN ENGINEER: J PATTERSON 11-16-09	SCALE NONE
TREATMENT		PROJECT MANAGER: B PERRIN 11-16-09	DATE 11-16-09	
APPROVALS		DATE	SCALE NONE	RELEASE DATE

SIZE D DWG NO. 3000-B-019



All Weather Inc.
1165 National Drive
Sacramento, CA 95834
USA
800.824.5873
www.allweatherinc.com

1190-001
April, 2010
Revision W