

# ASPIRATED SMOKE DETECTOR

## ASD1 (Single Channel)

### INSTALLATION, OPERATION & MAINTENANCE INSTRUCTIONS (CE)

#### 1 INTRODUCTION

The ASD1 has provision for one or two conventional/analogue addressable point detectors allowing for single, failsafe redundancy or mixed detection strategies.

The airflow level is displayed on a 10 element bar graph with adjustments for sensitivity and high/low flow thresholds. Flow failure is reported to the central panel as a detector/zone fault or via separate volt-free contacts.



**CAUTION!** THE ASD1 SYSTEM HAS BEEN INDEPENDENTLY TESTED AND CERTIFIED TO CEA4022 AND MUST BE INSTALLED IN STRICT COMPLIANCE WITH THE INSTRUCTIONS BELOW IF THE CERTIFICATION IS TO BE MAINTAINED

#### 2 SYSTEM INSTALLATION



**WARNING!** THIS EQUIPMENT MUST BE INSTALLED BY A QUALIFIED INSTALLER IN ACCORDANCE WITH ALL LOCAL AND NATIONAL REGULATIONS

Remove the transparent cover using the special tool provided to unscrew the tamper proof fasteners. Use the template provided to accurately position the holes then secure the unit to a suitable surface through the 4 corner fixing points. Ensure that the correct fasteners are used for the type of surface that the unit is mounted on.

#### 3 WIRING

For correct operation of the unit, it is essential that the case is fully sealed so that air can only be pulled into the system through the aspirating pipe. For this reason, all wiring must pass through the cable seals provided and no additional holes should be made. In order to pass a cable through a seal it is necessary to make a small hole in the centre of the seal with a pointed implement (e.g. small screwdriver) and then force the cable through the hole into the box. The small hole will expand to accommodate any cable diameter from 4 to 10mm and then provide an airtight seal.

In order to gain access to the main circuit board for connection of the wiring it is necessary to remove the display/detector mounting board, which is held in place by the clear top cover. Care should be taken when removing the board to ensure that the ribbon cable on the underside is not strained. The ribbon cable may be removed from the connector on the underside of the board to allow the board to be fully removed.



**WARNING!** TO PREVENT RISK OF ELECTRIC SHOCK, OR POSSIBLE INJURY FROM THE ROTATION OF THE HIGH PERFORMANCE FAN, THE SYSTEM SHOULD BE ISOLATED FROM THE SUPPLY WHEN THE TOP COVER IS REMOVED

All connections to the main circuit board are to pluggable terminals that can accommodate wire sizes up to 2.5mm<sup>2</sup>.

### 3.1 FIELD CONNECTIONS

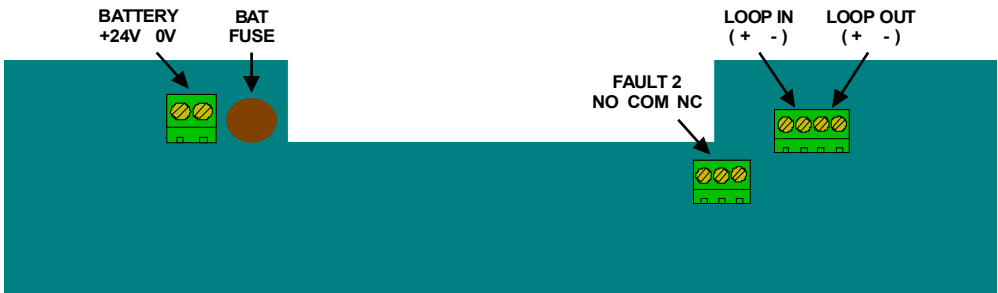

#### 3.1.1 BATTERY

The ASD1 unit is designed to run from a nominal 24V DC supply. The supply should be connected to the 2 way 'BATTERY' connector on the main circuit board ensuring that the wires are correctly orientated. It is recommended that the wires should be a minimum size of 16 x 0.25mm (18AWG), or larger if the supply is further than 5m from the system.



A ferrite core is provided for EMC compliance. This should be fitted to the supply wiring as shown above.

The power requirements are dependant on the fan speed – see table in Section 11.1 for details.

### 3.1.2 LOOP IN/LOOP OUT

The Loop In/Loop Out terminals are connected to the detector terminals on the display board. This provides a convenient means of connecting the loop/circuit wiring to the unit and allows the display and detectors to be removed during servicing by simply disconnecting the ribbon cable.

The loop/circuit wiring can also be connected directly to the detectors if required.

The connection to detector 1 terminal is via a relay contact that is closed under normal operating conditions but open in the event of a flow/fan/power fault. This takes detector 1 off the loop/circuit, which is interpreted by the panel as a fault condition.

 THIS MODE OF OPERATION SHOULD ONLY BE USED IF THE UNIT IS FITTED WITH 2 DETECTORS. IF A SINGLE DETECTOR IS USED THEN THE DETECTOR MUST BE FITTED TO THE DETECTOR 2 POSITION

### 3.1.3 FAULT 2

In the event of a fault condition, the Fault 2 relay will change state. The terminals provide for Normally Open (NO) or Normally Closed (NC) operation and these can be wired using terminating resistors to simulate a zone fault on a conventional control panel or via a loop interface module for an analogue addressable panel.

 NO/NC REFERS TO THE UN-POWERED STATE OF THE RELAYS AND UNDER NORMAL, NON FAULT, CONDITIONS NO IS CLOSED AND NC IS OPEN

## 4 POINT DETECTORS

Ensure that the selected detectors have sufficient sensitivity for the application. See Section 5 below for further details of how dilution affects detector sensitivity.

If the installation is to be in accordance with the CEA 4022 certification then the detector must have been tested for use in the system. Please refer to the list of approved detectors in Section 9.

### 4.1 BAFFLES

Due to the large variation in the sizes and shapes of point detectors it is necessary to fit baffles to the ASD to ensure that the sampled air flow is directed toward the detector. Each baffle is shaped to match a particular model/range of detectors and simply clips into position in the slots provided in the transparent lid.

## 4.2 DETECTOR INSTALLATION

One or two Conventional/Analogue Addressable Point Detectors are mounted on the display/mounting board using the screws provided. The detectors can then be wired to either the local terminals in the centre of the detector mounting points (then to the loop/conventional circuit via the Loop In/Loop Out terminals on the main circuit board) or directly to the loop/conventional circuit with the wiring passing through the cut-outs on the display/mounting board.

## 4.3 WIRING EXAMPLES

The following examples show typical installations for conventional and analogue addressable detectors –

KEY – (1) Display/Detector Mounting Board (2) Main Circuit Board  
(3) Ribbon Connector (4) Detector 1 Relay Contacts (5) Detector 1  
(6) Detector 2 (7) Terminating Resistor (8) Loop Interface Module  
(9) Addressable Loop/Conventional Circuit

### 4.3.1 ASD1 WITH SINGLE CONVENTIONAL DETECTOR

Detector **MUST** be fitted to position 2. Terminating resistor may be fitted to position 1 if required.

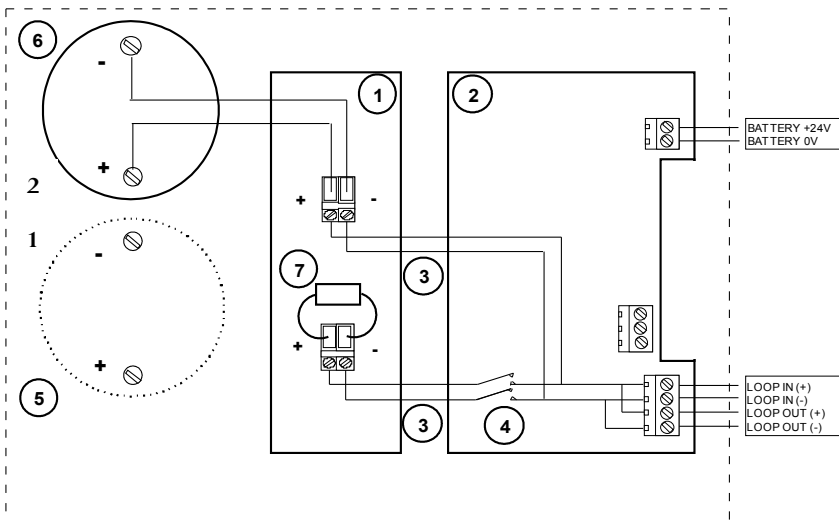

### 4.3.2 ASD1 WITH 2 x CONVENTIONAL DETECTORS

Terminating resistor fitted to detector in position 1 if required.

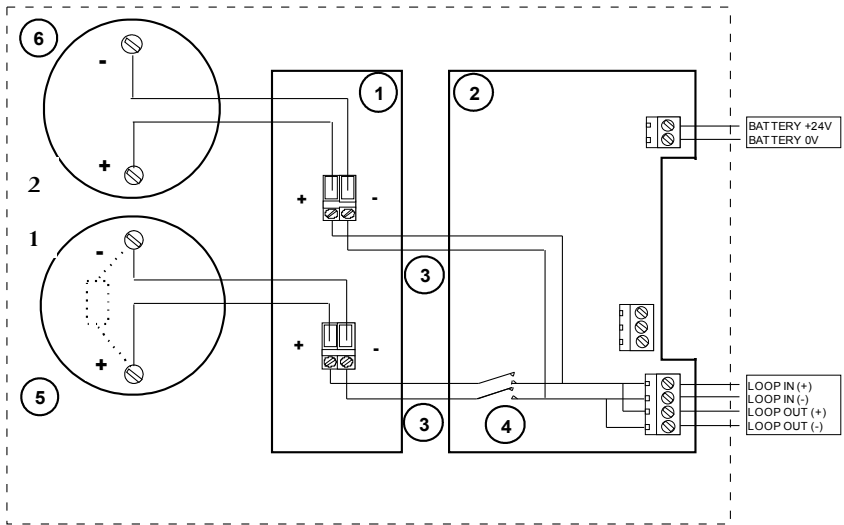

### 4.3.3 ASD1 WITH 2 x ADDRESSABLE DETECTORS

Detectors wired directly to loop with Fault 2 relay connected to loop via addressable module

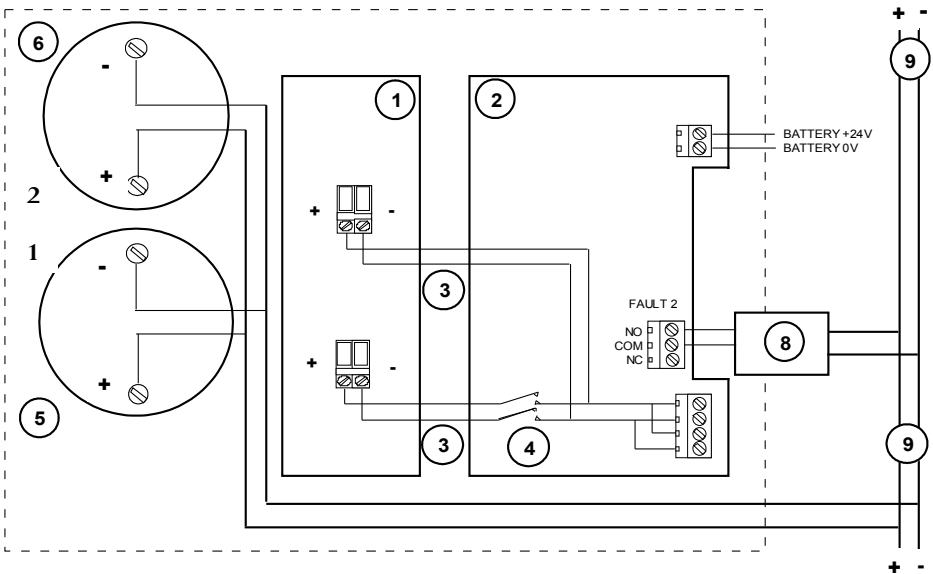

### 4.3.4 SERIES OF ASD1 UNITS ON A CONVENTIONAL DETECTION CIRCUIT

Schematic shows first and last units. Zone circuit wiring returned from last unit to first via Fault 2 relay contacts in each unit and terminating resistor fitted to first unit as shown. Flow fault condition in any unit will break the connection to the terminating resistor and indicate a zone fault without affecting the operation of the detectors themselves

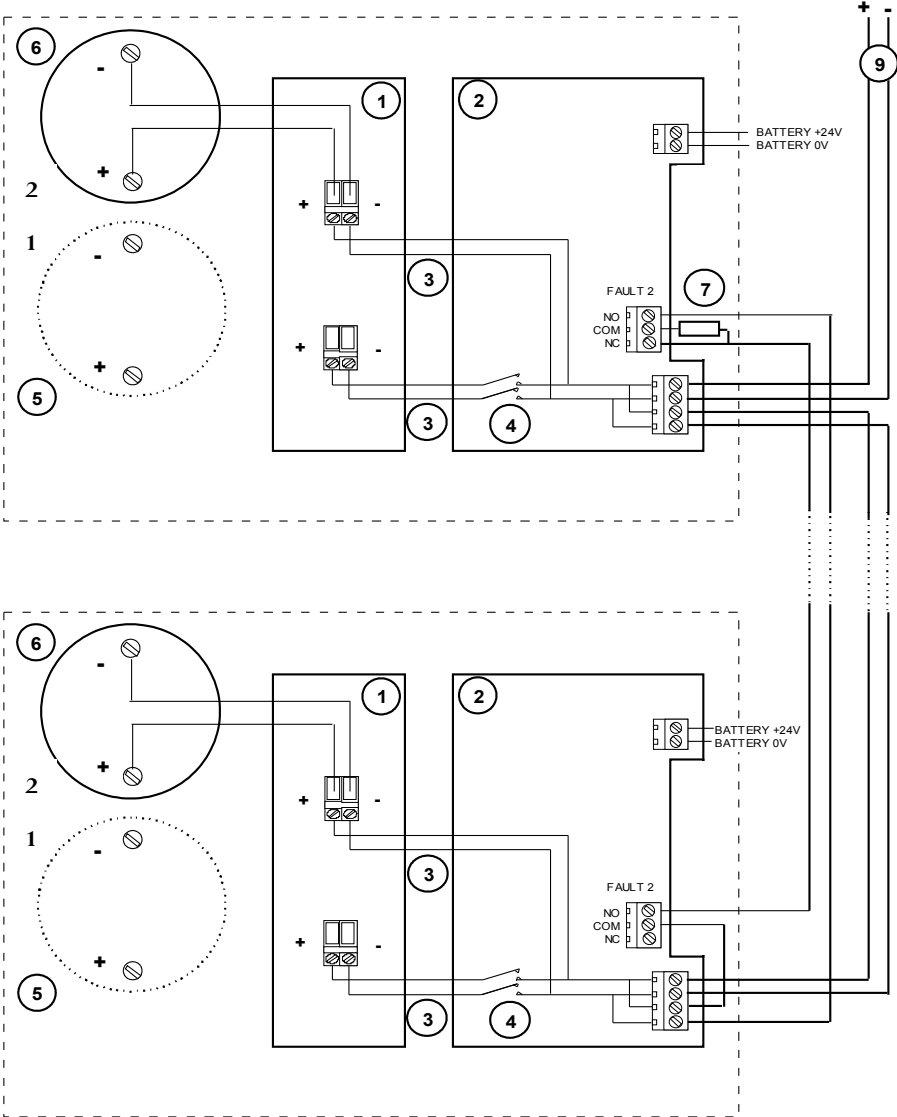

## 5 PIPE INSTALLATION

A simple guide to pipe installation follows with examples of standard configurations and should contain all the information required for simple installations based on the standard configurations.



REFER TO THE PIPE INSTALLATION MANUAL (AVAILABLE AS OPTIONAL CD-ROM OR DOWNLOAD FROM FIRETRACER.COM) FOR DETAILED INFORMATION AND MORE PRACTICAL EXAMPLES

THE PIPETRACER SOFTWARE (AVAILABLE AS OPTIONAL CD-ROM OR DOWNLOAD FROM FIRETRACER.COM) SHOULD BE USED TO CALCULATE TRANSPORT TIMES, DILUTION EFFECTS ETC. FOR ALL INSTALLATIONS BEYOND THE SCOPE OF THIS GUIDE

Use 25mm (or ¾") Red ABS pipe with sampling point holes drilled along its length. The pipe run is terminated with an end cap that has a hole drilled in its centre.

The position of each individual sampling point should be in accordance with the rules for the positioning of point detectors. It is important to note that the concentration of smoke on an individual sample point will be diluted by the clean air from the other sample points and the end cap hole.

### 5.1 PIPE SPECIFICATION

For CEA4022 compliance, the pipe should be Red ABS to EN 50086-1 (Crush 1, Impact 1, Temp 33) with a nominal diameter of 25mm (or ¾"). The sample pipe is normally supplied in 3 metre lengths and is cut as required and joined by solvent welded sockets (permanent), or socket unions (removable).



THE ASD1 INLET PORT IS TAPERED TO ALLOW A PUSH FIT OF THE SAMPLING PIPE. THE PIPE SHOULD BE CUT SQUARELY TO ENSURE A GOOD, AIRTIGHT SEAL. SOLVENT ADHESIVE SHOULD NOT BE USED FOR THIS JOINT

### 5.2 FIXINGS

The normal fixing methods are pipe clips, saddle clamps or even tie wraps. Fixing centres are typically 1.5m apart.

### 5.3 HOLES

The sampling pipe is perforated with sampling holes and can either be pre-drilled or drilled in situ. Care should be taken to avoid swarf entering the pipe. Always blow compressed air through the pipe after drilling to clear any debris before final connection to the equipment. In standard configuration, with pipe

hanging from ceiling, the holes should be placed underneath, so the smoke can easily rise up into the hole.

### 5.4 END CAP

The end of the pipe is terminated with a cap, with a hole drilled in its centre. If the end cap is not used, then practically no air will be drawn through the side holes. If the end cap does not have a hole then the contributions from the side holes will tend to be very unbalanced.

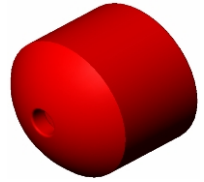

### 5.5 BENDS

Bends are either 45 or 90 degrees. For the 90-degree bends, it is very important that swept bends are used and not sharp elbows, as this will introduce unacceptable pressure losses, and significantly increase the response times from holes beyond the bend.

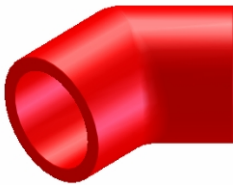

### 5.6 EXHAUST

In most installations the exhaust should be left open but there are some circumstances when it may be necessary to connect pipe to the exhaust port to divert the exhaust away from the location of the unit e.g. to reduce noise, reduce risk of interference/deliberate obstruction, improved environmental protection etc.

Pipe of the same specification as the sample runs should be used and its length limited to a maximum of 10m to avoid significant reduction in the air flow. Care should be taken to position the new exhaust outlet where it cannot be accidentally or deliberately blocked.

### 5.7 FILTERS

The sampled air is passed through a 2 stage filter – *replacement order code FL55* - before entering the detector chamber.







As standard, the filtration should be sufficient for all but extremely dusty conditions where a Harsh Environment Filter – order code *FLU1* (3/4") / *FLU2* (25mm) - should be fitted between the unit and the first sampling point.

## 5.8 STANDARD CONFIGURATIONS (Drawings not to scale)



### 5.8.1 Configuration 1 ASD1 with single pipe

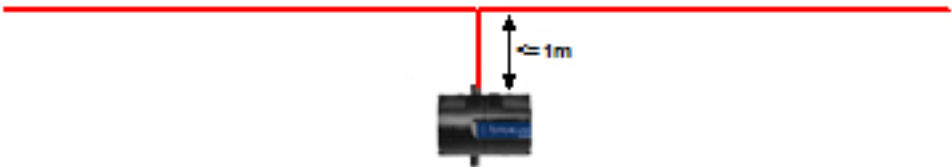

### 5.8.2 Configuration 2 ASD1 with Tee and 2 pipes - Distance from unit to Tee must be $\leq 1\text{m}$ and pipes should be balanced i.e. equal length and equal number of holes.

The use of additional bends as described in Section 5.5 will have a minimal effect on performance – i.e. response time, of either configuration.



THE PIPETRACER SOFTWARE SHOULD BE USED TO VERIFY THE PERFORMANCE OF ANY NON-STANDARD CONFIGURATIONS OR WHERE UNBALANCED PIPE RUNS ARE REQUIRED

SEE TABLE IN SECTION 9 FOR CEA 4022 HOLE AND PIPE LENGTH LIMITS FOR CERTIFIED DETECTORS

## 6 SETUP

### 6.1 DISPLAY FUNCTIONS

1

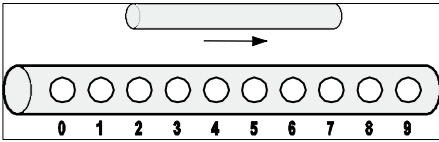





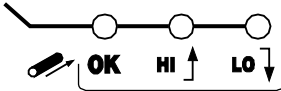

BARGRAPH of AIRFLOW SPEED

2, 3, 4



AIRFLOW OK - HIGH AIRFLOW - LOW AIRFLOW

- 5  POWER ON
- 6  GENERAL FAULT (Mains PSU Option Only)
- 7  MAINS FAILURE (Mains PSU Option Only)
- 8  BATTERY LOW (Mains PSU Option Only)
- 9  FAN FAULT
- 10  **CODE** CODE ENTRY



## 6.2 USER FUNCTIONS

Press and hold SELECT and CHANGE keys simultaneously for 1 second to initialise function selection.

Press and release SELECT key to sequentially step through functions.

Press and release CHANGE key to modify setting.

The relevant LED flashes continuously to indicate the function selected.

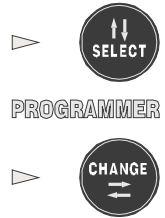

- 1) Enter 3 digit access code - 510. Each number must be selected in turn. e.g. press CHANGE six times to illuminate the number 5 LED on the display then press SELECT etc. (CODE LED flashes – UNLOCK LED illuminates on successful entry).
- 2) Set fan speed (POWER LED flashes)
- 3) Set sensitivity of bar graph to changes in airflow velocity (FLOW OK flashes)
- 4) Select the BARGRAPH LED segment above which the FLOW HIGH LED will be illuminated (FLOW HIGH flashes)
- 5) Select the BARGRAPH LED segment below which the FLOW LOW LED will be illuminated (FLOW LOW flashes)
- 6) Calibrate flow sensors (FAN FAULT LED flashes). CHANGE key must be pressed for at least 2 seconds to initiate the flow calibration process. FAN and POWER LEDs flash to indicate calibration in progress. Fan is temporarily stopped as part of the calibration process. The system will reset and revert to normal operating mode when flow calibration is completed.

Pressing the SELECT key for longer than 1 second when the unit is unlocked will cause the unit to revert to normal operating mode.

## 6.3 SET-UP NOTES

The Fan Speed, Flow Limits and Flow Sensitivity need to be set for each installation prior to Flow Calibration and testing. It is not possible to provide the settings for all possible installations but the following guidelines should assist in the commissioning of the unit.

### 6.3.1 FAN SPEED

The Fan Speed should be set as high as possible to achieve the fastest transport time from the sampling point to the detectors, this is especially important for longer pipe lengths and for installations that must conform to the requirements of CEA4022 (see Section 9). There is, however, a balance to be achieved between performance and the units power requirements and reference should be made to the current consumption figures in the specifications prior to setting this value. Fan speeds 3 and below should not be used for standard configurations.

### 6.3.2 FLOW SENSITIVITY

This setting determines the systems responsiveness in reporting blocked sampling points or broken pipes. The number of sampling points and fan speed are the main factors to consider for this setting.

The following table shows typical settings for a variety of standard fan speed/hole quantity combinations. Other speed/hole combinations should be verified by testing during commissioning.

<b>6.3.2.1 TYPICAL FLOW SENSITIVITY SETTINGS</b>		
<b>PIPE SETUP (all 50m lengths unless otherwise stated)</b>	<b>RECOMMENDED FAN SPEEDS</b>	<b>FLOW SENSITIVITY</b>
13 x 3mm Sampling Holes, 1 x 6mm End Hole	9	9
8 x 3mm Sampling Holes, 1 x 6mm End Hole	6-9	9
4 x 3mm Sampling Holes, 1 x 6mm End Hole	6-9	7
1 x 5mm Sampling Hole, 1 x 5mm End Hole	6-9	5
1 x 8mm End Hole	5-9	2
1 x 8mm End Hole (10m Pipe)	3-9	1

## 7 TESTING



TESTING SHOULD ONLY BE CARRIED OUT BY QUALIFIED PERSONNEL. BEFORE UNDERTAKING ANY TESTING ENSURE THAT THE PROPER AUTHORITIES HAVE BEEN INFORMED AND THAT THE UNIT HAS BEEN ISOLATED FROM THE FIRE CONTROL PANEL IF NECESSARY TO PREVENT UNWANTED ALARMS

### 7.1 DETECTORS

With the unit powered up and top cover removed the detectors can be tested for functionality using methods described by the manufacturer e.g. aerosol spray etc.

### 7.2 SYSTEM

The installed system must be checked with the top cover securely fitted.

As a minimum, smoke should be introduced to the furthest sampling point from the ASD unit on each branch of the pipe. The choice of smoke source is dependant on the installation but in all cases, the smoke must be present for the duration of the test – aerosol sprays for point detectors do NOT work on aspirated systems.

If it is possible to get close to the sampling point then a basic, functional check can be carried out with smoke matches or lighted taper etc. but for measurable performance, tests then refer to Appendix A of the BFPSA Code of Practice for Aspirating Systems to select the appropriate test for the installation.

## 8 MAINTENANCE

With normal use, the filter elements will eventually become contaminated with dust particles, impeding airflow, and it is recommended that the filter elements – *order code FL55* - are changed every six months.



MAINTENANCE SHOULD ONLY BE CARRIED OUT BY QUALIFIED PERSONNEL. BEFORE CARRYING OUT ANY MAINTENANCE, NOTIFY THE PROPER AUTHORITIES AND ISOLATE UNIT FROM THE FIRE CONTROL PANEL TO PREVENT UNWANTED ALARMS

1. Remove the transparent cover using the special tool provided to unscrew the tamper proof fasteners.

2. Lift out the foam filter elements from the filter tube (tweezers or long nosed pliers are recommended for this operation).
3. Fit a new filter element set ensuring that the coarse grade filter is inserted into the tube first. Care should be taken to ensure that the filters are not compressed during fitting and that the fine filter is positioned flush with the top of the filter tube.
4. Replace the top cover



DETECTORS SHOULD BE SERVICED IN ACCORDANCE WITH THE MANUFACTURERS RECOMMENDATIONS

## 9 CEA 4022 CERTIFIED DETECTORS

The following detectors have been independently tested and certified for use in the ASD1 unit. The table shows the limits that should not be exceeded if the installation is to conform to this requirement. All figures are based on the standard configurations shown in Section 5.8. Pipe lengths are 50m pipe with a fan speed of 9 unless otherwise stated.

Detector Brand	Detector Model	Configuration 1 Sampling hole limits	Configuration 2 Sampling hole limits
<b>APOLLO</b>	S65 Optical	1 x 8mm End Hole	n/a
	XP95 Optical	1 x 8mm End Hole	n/a
	DISCOVERY Optical <sup>1</sup>	1 x 8mm End Hole	n/a
	DISCOVERY Optical <sup>2</sup>	2 x 5mm Holes	n/a
<b>DETECTOMAT</b>	CT 3000 O	1 x 8mm End Hole	n/a
	PL 3200 O	1 x 8mm End Hole	n/a
	PL 3300 O	1 x 8mm End Hole	n/a
<b>GE SECURITY</b>	DP 331I	1 x 8mm End Hole	n/a
	DP 721I	3 x 4mm Holes	n/a
	DP 2061 <sup>3</sup>	6 x 4mm Holes	n/a
	DP 951	1 x 8mm End Hole	n/a
<b>HOCHIKI</b>	SLR-E3	1 x 8mm End Hole	n/a
	ALG-E	1 x 8mm End Hole	n/a
<b>SYSTEM SENSOR</b>	2251EM <sup>4</sup>	1 x 8mm End Hole	n/a
	2251EM <sup>5</sup>	2 x 5mm Holes	n/a
	7251 PINNACLE <sup>6</sup>	13 x 3mm,6mm end	8 x 3mm, 6mm end <sup>7</sup>
	7251 PINNACLE <sup>6</sup>	75m Pipe – 11 x 3mm,6mm end	n/a

1) Using standard sensitivity alarm level of 55

2) Using pre-alarm sensitivity level of 45

3) Using high sensitivity mode

4) Using standard sensitivity alarm level of 2200

- 5) Using high sensitivity alarm level of 1800
- 6) Using alarm level 3
- 7) Per branch



SIGNIFICANT REDUCTIONS IN PIPE LENGTH MAY ALLOW THE FAN SPEED TO BE REDUCED AND/OR NUMBER OF HOLES INCREASED. RESULTS OF SUCH CHANGES MUST BE VERIFIED WITH THE PIPETRACER SOFTWARE.

OTHER DETECTORS AND PIPE LENGTHS UP TO 100m MAY BE USED IF CEA 4022 CERTIFICATION IS NOT A REQUIREMENT. DESIGNS SHOULD BE VERIFIED WITH THE PIPETRACER SOFTWARE TO ENSURE THAT THE PERFORMANCE IS SUITABLE FOR THE INTENDED APPLICATION.

## 10 PROBLEM SOLVING

PROBLEM	POSSIBLE SOLUTIONS
Power light flashing.	Ensure supply to BATTERY connector within limits.
No lights on display. Fan not running	Ensure supply leads correctly orientated. Ensure that BAT FUSE correctly seated in socket and fuse not blown.
No lights on display. Fan running OK.	Ensure ribbon cable fully seated into main & display boards.
Flow HI/LO light on	Ensure sampling pipes correctly installed, lid fitted and box fully sealed. Ensure flow calibration procedure has been carried out (Section 6.2). Ensure filters are clean (Section 8)
Flow reading on Bargraph display moves erratically.	Decrease Flow sensitivity setting and re-calibrate air flows (Section 6.2).
Flow reading on Bargraph unresponsive to broken/blocked pipes	Increase Flow sensitivity setting and re-calibrate air flows (Section 6.2).
Detector(s) unresponsive to smoke tests	Ensure sampling pipe installed correctly and undamaged (Section 5). Ensure that holes and pipe length do not exceed limits for detector (Section 9). Ensure that recommended baffles are fitted (Section 4.1). Ensure that recommended test method is used (Section 7.2). Increase fan speed and re-test.

## 11 SPECIFICATIONS

Number of Detectors (not supplied)	1 or 2 Analogue Addressable or Conventional
Filtration	2 Stage, cartridge dust particle filter
Flow Monitoring	Thermal device, high and low thresholds. 10 element bar graph indication. Loop or relay fault reporting.
Supply Voltage	18-30V DC (24V DC Nominal)
Maximum Supply Current	350mA @24V DC with no aspirating pipe. See table below for typical Currents/Fan Speeds
Maximum Pipe Length	Up to 100 + 100 metres in Tee configuration (50m + 50m for CEA 4022) dependant on detector type & application
Environmental Protection	IP65 with exhaust fitted (IP53 without)
Operating Temperature	-10 to 50°C
Operating Humidity	10 to 95% RH (non-condensing)
Approvals	CEA 4022 by VdS (G206066)
CE Certification	EN61000-6-3:2001(+A11:2004) (EMC) EN60950-1:2006 (Safety)

### 11.1 TYPICAL SUPPLY CURRENT/FAN SPEED

Bargraph Value	0	1	2	3	4	5	6	7	8	9
Fan Speed	1	2	3	4	5	6	7	8	9	10
Current (mA)	110	120	130	150	170	190	220	235	265	300

Typical current consumption figures for different fan speeds. Results are based upon an ASD2 installation with 10m of standard, 25mm aspirating pipe per channel. The unit was powered from a 24V supply.

#### WEEE DIRECTIVE 2002/96/EC (Waste Electrical and Electronic Equipment)

The symbol shown is marked on this product to indicate that it must not be disposed of with other waste. Instead, it is the user's responsibility to dispose of their waste equipment by handing it over to a designated collection point for the recycling of waste electrical and electronic





equipment. The separate collection and recycling of your waste at the time of disposal will help to conserve natural resources and ensure that it is recycled in a manner that protects human health and the environment. For more information about where you can drop off your waste equipment for recycling, please contact your local city office, your household waste disposal service or where you purchased the product.

**GLT Exports Limited,**

Detection House,  
72-78 Morfa Road,  
Hafod,  
Swansea,  
SA1 2EN,  
United Kingdom  
Telephone +44 (0)1792 455175  
Fax +44 (0)1792 455176  
e-mail address: [sale@gltextports.com](mailto:sale@gltextports.com)  
web site: [www.zeta-alarms.co.uk](http://www.zeta-alarms.co.uk)



ASD1 Manual (CE) – Issue 10.0  
Part No. 09-0101-10