

USER'S MANUAL

Revision: 3



HEC-200x-E-R Harsh Environment Controller

Covered Models:

HEC-2000-E-R
HEC-2001-E-R
HEC-2002-E-R
HEC-2003-E-R
HEC-2004-E-R



Divelbiss Corporation
9778 Mt. Gilead Road,
Fredericktown, Ohio 43019

Toll Free: 1-800-245-2327
Web: <http://www.divelbiss.com>
Email: sales@divelbiss.com

Manual Contents

Getting Started

| | |
|--|---|
| How to Use this Manual | 3 |
| Configuring the HEC-200x-E-R Target in EZ LADDER Toolkit | 4 |
| Loading the HEC-200x-E-R Kernel | 4 |
| Getting to Know the HEC-200x-E-R | 6 |
| Assembling / Dis-Assembling the HEC-200x-E-R | 8 |

HEC-200x-E-R Features

| | |
|--|----|
| Programming Port | 10 |
| Watchdog LED | 11 |
| Status LED | 11 |
| Input Power | 11 |
| Mounting | 12 |
| Digital Inputs | 13 |
| Counter Inputs | 14 |
| Digital Outputs | 15 |
| Pulse Width Modulation Outputs | 16 |
| General Purpose Serial Port - Models HEC-2001-2003-E-R | 18 |
| General Purpose Serial Port - Models HEC-2004-E-R | 20 |
| CAN Networking Ports | 21 |
| HEC-200x-E-R Target Setting Options | 21 |
| Specifications | 22 |

WARNING!!

The HEC-200x-E-R, as with other programmable controllers must not be used alone in applications which could be hazardous to personnel in the event of failure of this device. Precautions must be taken by the user to provide mechanical and/or electrical safeguards external to this device. This device is **NOT APPROVED** for domestic or human medical use.

Getting Started

This section explains how to read this manual and understand the symbols and information that it contains.

To begin using your HEC Controller, you will need to follow these steps:

- Install EZ LADDER Toolkit if not already installed (not included).
- Configure the HEC Controller in the EZ LADDER Toolkit Project Settings.
- Using purchased or self-made cables, connect the Input Power and Programming Port.
- Write a ladder diagram program.
- Install the HEC Kernel if this is a new unit from the factory.
- Download and run the program on the HEC Controller.

Refer to the appropriate sections of this manual for details on the above items.

How to Use this Manual

In this manual, the following conventions are used to distinguish elements of text:

| | |
|-------------------|--|
| BOLD | Denotes labeling, commands, and literal portions of syntax that must appear exactly as shown. |
| <i>italic</i> | Used for variables and placeholders that represent the type of text to be entered by the user. |
| SMALL CAPS | Used to show key sequences or actual buttons, such as OK, where the user clicks the OK button. |

In addition, the following symbols appear periodically in the left margin to call the readers attention to specific details in the text:



Warns the reader of a potential danger or hazard associated with certain actions.



Appears when the text contains a tip that is especially useful.



Indicates the text contains information to which the reader should pay particularly close attention.

All Specifications and Information Subject to Change without Notice

Configuring the HEC-200x-E-R Target in EZ LADDER Toolkit

Before you can program and use the HEC Controller, it must be configured as a target within the EZ LADDER Toolkit. For help with installing or using EZ LADDER, please refer to the EZ LADDER User's Manual.

1. In EZ LADDER, from the File Menu at the top, click **PROJECT** then **SETTINGS**. This will open the Project Settings Window. Select **HEC-2000** as the target from the choices. Refer to Figure 1.1. Verify the Port is correct and the baud rate is 57600.

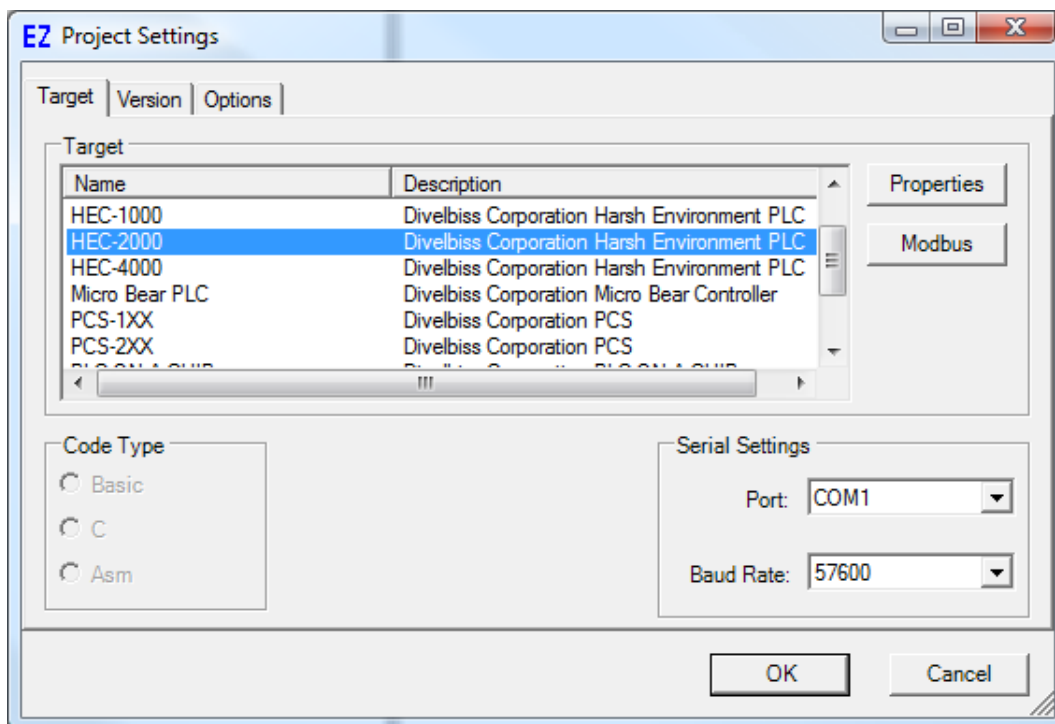

Figure 1.1 - Project Settings Window



2. Click **OK**. This will close the Project Settings Window, saving the HEC-2000 as the target for this ladder diagram project.

Loading the HEC-200x-E-R Kernel

THE HEC-200X-E-R WILL NOT FUNCTION UNLESS THIS STEP (KERNEL LOADING) IS COMPLETED.

The kernel is the firmware for the controller and to provide greater flexibility and reliability, HEC Controller shipments are factory shipped **without** a kernel. If this is a new unit from the factory, it will be necessary to load the kernel before a ladder program can be downloaded. If the kernel is already loaded, this step is not required. To upgrade a kernel, see the EZ LADDER User's Manual.

To install the HEC-200x-E-R's kernel:

1. Verify the target has been configured (see *Configuring the HEC-200x-E-R Target in EZ LADDER Toolkit*).
2. Connect the Programming cable(s) from the computer to the HEC-200x-E-R. See *Programming Port* in the *HEC-200x-E-R Features* section.
3. Create a small one-rung program with a normally open (direct contact) and an output tied together. You may also open a pre-existing program for the HEC. EZ LADDER version 1.0.4.4 and later includes a sub-directory (...EZ LADDER\Kernel Install Start Programs\)which has starter programs for each target to load the kernel. Choose **GetStarted_HEC-200X.dld**.
4. Click the  (Compile) button
5. Click the  (Monitor) button to change from the 'Edit' to 'Monitor' Mode.
6. Click the  (Connect) button to connect to the target. A dialog will appear automatically when no kernel is loaded. If this dialog does not appear, click **PROJECT** then **BOOTLOADER**.
7. Click the **BROWSE** button and select the target's kernel (by partnumber) located by default at C:\Program Files\EZ Ladder\Kernel\

The following are kernel names and descriptions:

| <u>File Name</u> | <u>Description</u> | <u>To be Used on (Partnumber)</u> |
|------------------|-------------------------|--|
| HEC_2000.dat | Kernel for HEC-200x-E-R | HEC-2000-E-R, HEC-2001-E-R, HEC-2002-E-R HEC-2003-E-R, HEC-2004-E-R |

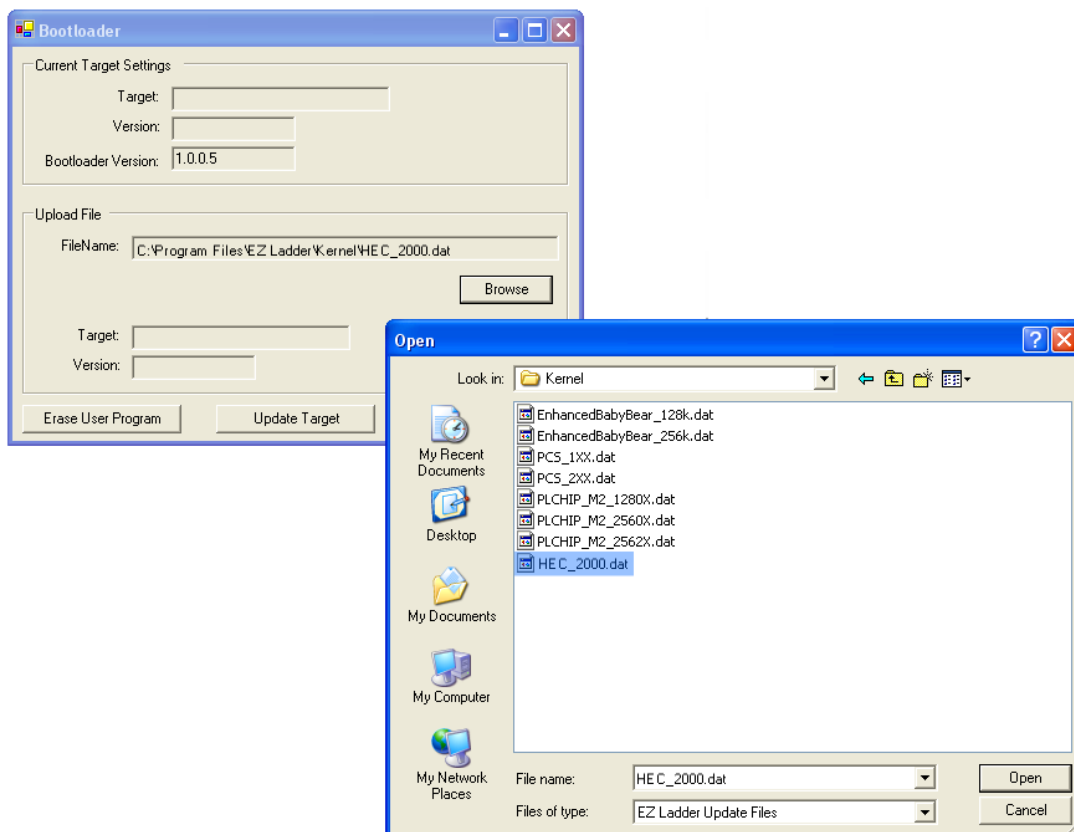

- Click the **OPEN** button to finish the kernel selection. Make sure the correct kernel is chosen.
- Click the **UPDATE TARGET** button to install the kernel.

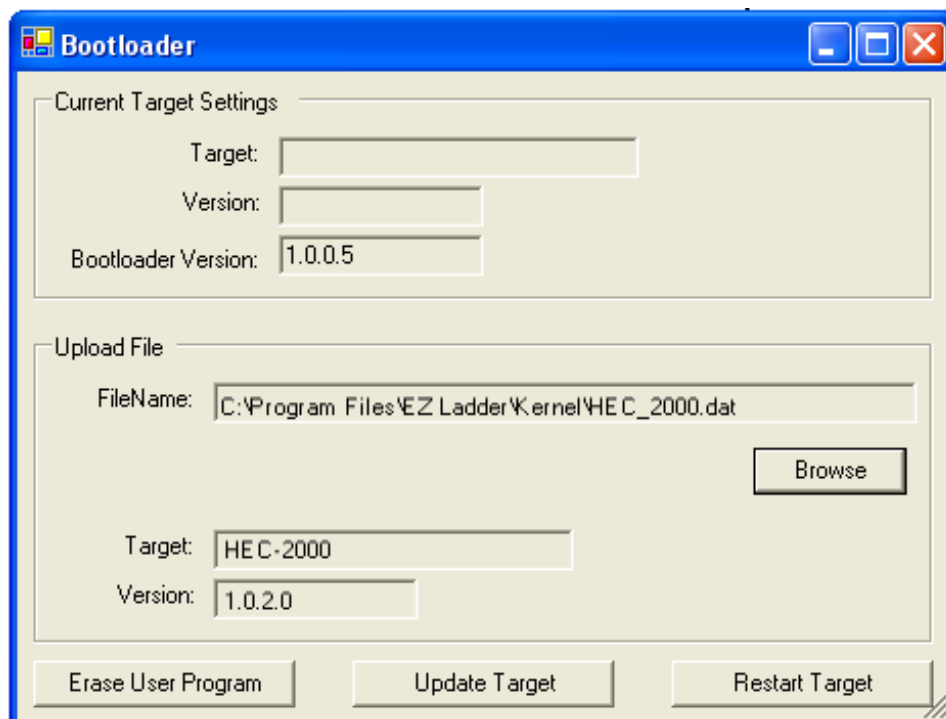

- A dialog box will appear to show the status of the kernel installation. This could take a couple of minutes to install.
- When the dialog windows close, the installation is complete. The HEC is ready to use and may be connected to and programs may be downloaded.

Getting to Know the HEC-200x-E-R

The HEC-200x-E-R Controller is designed to provide powerful programmable features in a tough, harsh environment resistant package. The main features of the HEC-200x-E-R are accessed via sealed Deutsch connectors that will be referred to as the 'A' connector which is grey and the 'B' connector which is black.

Refer to Figure 1.2, it illustrates the HEC-200x-E-R.

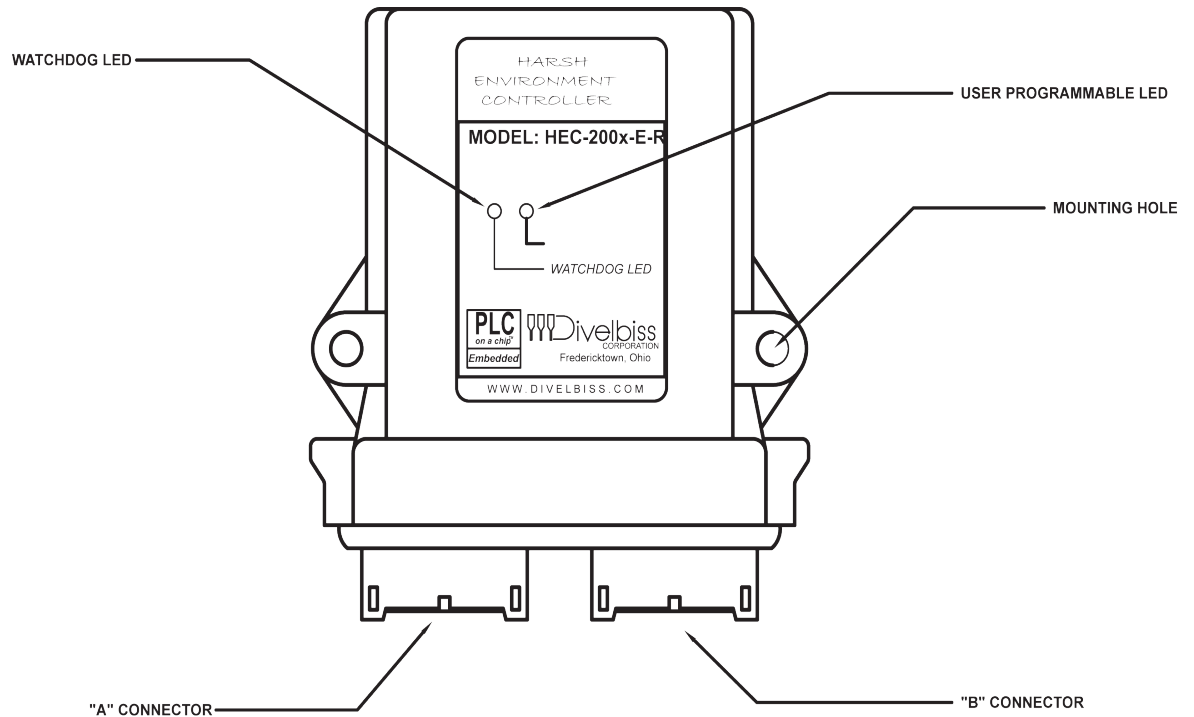

Figure 1.2 - HEC-200x-E-R Product Drawing

Each HEC connector is a Deutsch sealed connector with 12 connections each.

The mating connectors for the HEC's connectors are sold separately. Connectors may be purchased as kits or cable assemblies may be purchased with the mating connectors pre-wired with flying leads on one end.

In addition to connectors and kits for standard wiring, several programming break-out cable assemblies may be purchased.

Refer to Figure 1.3 for the HEC-200x-E-R A and B connector front view Pin Assignments.

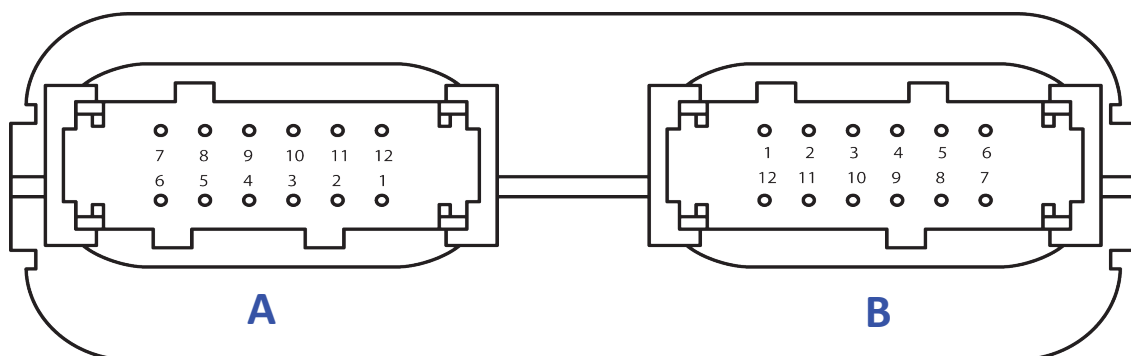

Figure 1.3 - HEC-200x-E-R A / B Connector Front View

A and B Connector Pin Functions

CONNECTOR 'A' (GRAY)

| | |
|--------|--------------------------|
| Pin 1 | Input 4 (GPI4) |
| Pin 2 | Input 5 (GPI5) |
| Pin 3 | CAN Hi |
| Pin 4 | CAN Low |
| Pin 5 | Programming Port TX |
| Pin 6 | Programming Port RX |
| Pin 7 | +VDC Input Power |
| Pin 8 | +VDC Input Power |
| Pin 9 | +VDC Input Power |
| Pin 10 | -DC / Input Power Common |
| Pin 11 | Input 7 (GPI7) / CNTR 2 |
| Pin 12 | Input 6 (GPI6) / CNTR1 |

CONNECTOR 'B' (BLACK)

| | |
|--------|------------------------------|
| Pin 1 | Output 0 / PWM 0 (GPO0/PWM0) |
| Pin 2 | Output 1 / PWM 1 (GPO1/PWM1) |
| Pin 3 | Output 2 / PWM 2 (GPO2/PWM2) |
| Pin 4 | Output 3 / PWM 3 (GPO3/PWM3) |
| Pin 5 | Output 4 / PWM 4 (GPO4/PWM4) |
| Pin 6 | Output 5 / PWM 5 (GPO5/PWM5) |
| Pin 7 | Input 0 (GPI0) |
| Pin 8 | Input 1 (GPI1/) |
| Pin 9 | Input 2 (GPI2) |
| Pin 10 | Input 3 (GPI3) |
| Pin 11 | Output 7 / PWM7 (GPO7/PWM7) |
| Pin 12 | Output 6 / PWM6 (GPO6/PWM6) |

Assembling / Dis-Assembling the HEC-200x-E-R

To dis-assemble the HEC Controller you will need a flat-head screwdriver.

1. Place the screwdriver as shown, press in on the locking latch (of the connector assembly) and push forward gently simultaneously to slide the locking latch out of the enclosure .
2. Repeat this for the second side and slide the entire connector assembly with the printed circuit board out of the enclosure.

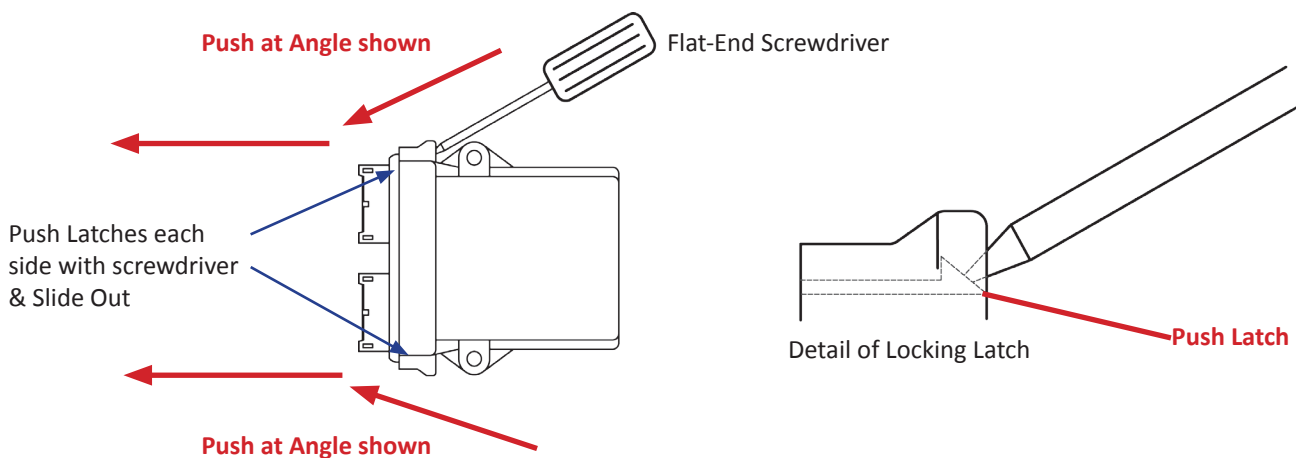

To assemble the HEC Controller:

1. Align the connector assembly with printed circuit board into the enclosure. The printed circuit board will align with the slots in the enclosure.
2. Slide the assembly completely into the enclosure until the locking latches are secure. Please note: If the HEC controller has an optional serial port, make sure the serial board wires do not interfere or get caught on the enclosure's LED pipes (clear plastic tubes).

HEC-200x-E-R Features

This section explains the Harsh Environment Controller (HEC-200x-E-R) hardware features, options and information regarding EZ LADDER Toolkit for basic operation.

Programming Port

! The HEC-200x-E-R is programmed using its Programming Port (COM 0). This RS232 serial port is only to be used for programming using Divelbiss EZ LADDER Toolkit software. This is not a general purpose port and may not be used in any other capacity than programming the controller itself.

The Programming Port defaults to:

| | |
|-------------|-------|
| Baud: | 57600 |
| Parity: | None |
| Data Bits: | 8 |
| Stop Bits : | 1 |

! The HEC-200x-E-R Programming Port is wired through the A Connector just as other features. The Programming Port requires a NULL MODEM cable or connection to the computer to establish communications between EZ LADDER Toolkit and the HEC Controller.

This connection may be made by manufacturing your own programming cable. The mating connector for the HEC-300x-E-R Programming Port may be purchased as a kits (HEC-10, Requires special Crimp Tool) or a complete pre-wired assembly for the A Connector (HEC-100). Ideally, the best option is to purchase the HEC-910 Breakout Cable Assembly. This cable assembly connects in-line with all connected devices and provides an RS232 9-pin D Male connector as the interface. This also requires a null modem cable (ICM-CA-34) that connects from the HEC-910 to the computer serial port. While this is the most commonly used programming cable set, other programming cable set options are available.

Refer to Figure 2.1 for Direct Connections and Figure 2.2 for the HEC-900 Break-out method.

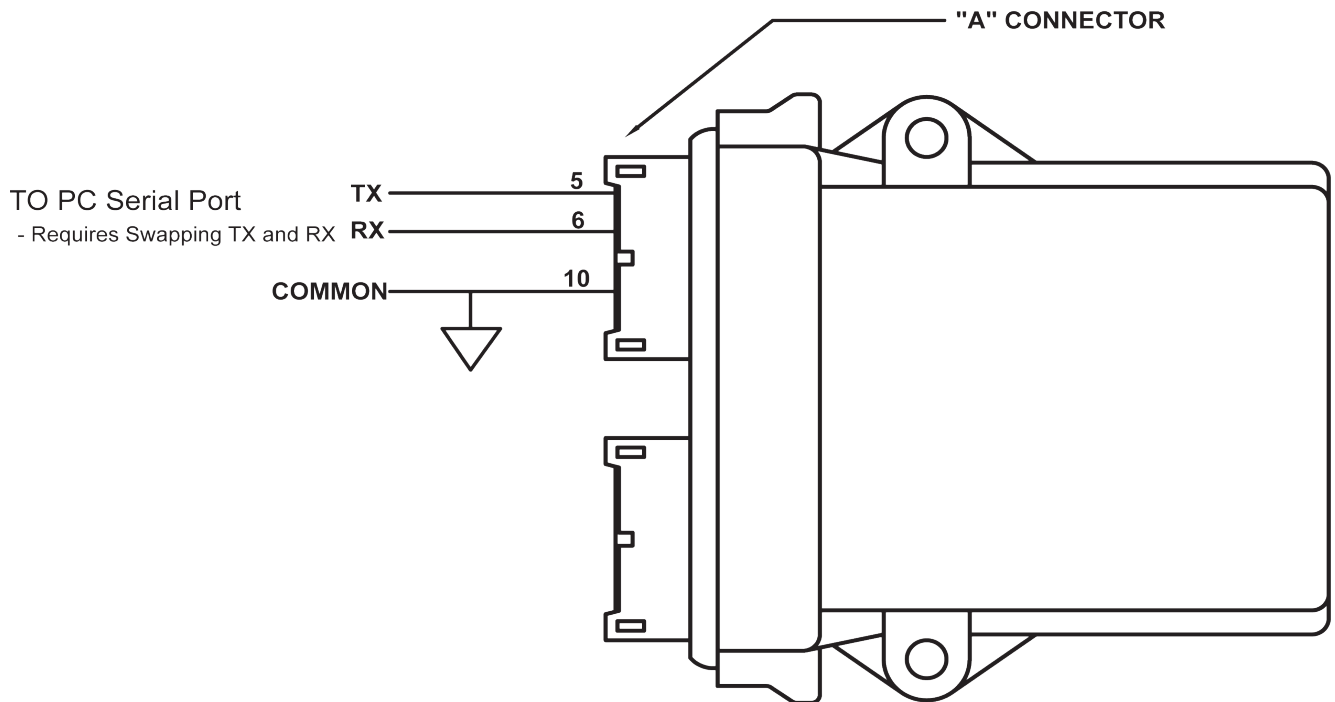

Figure 2.1 - Programming Port Direct Connection

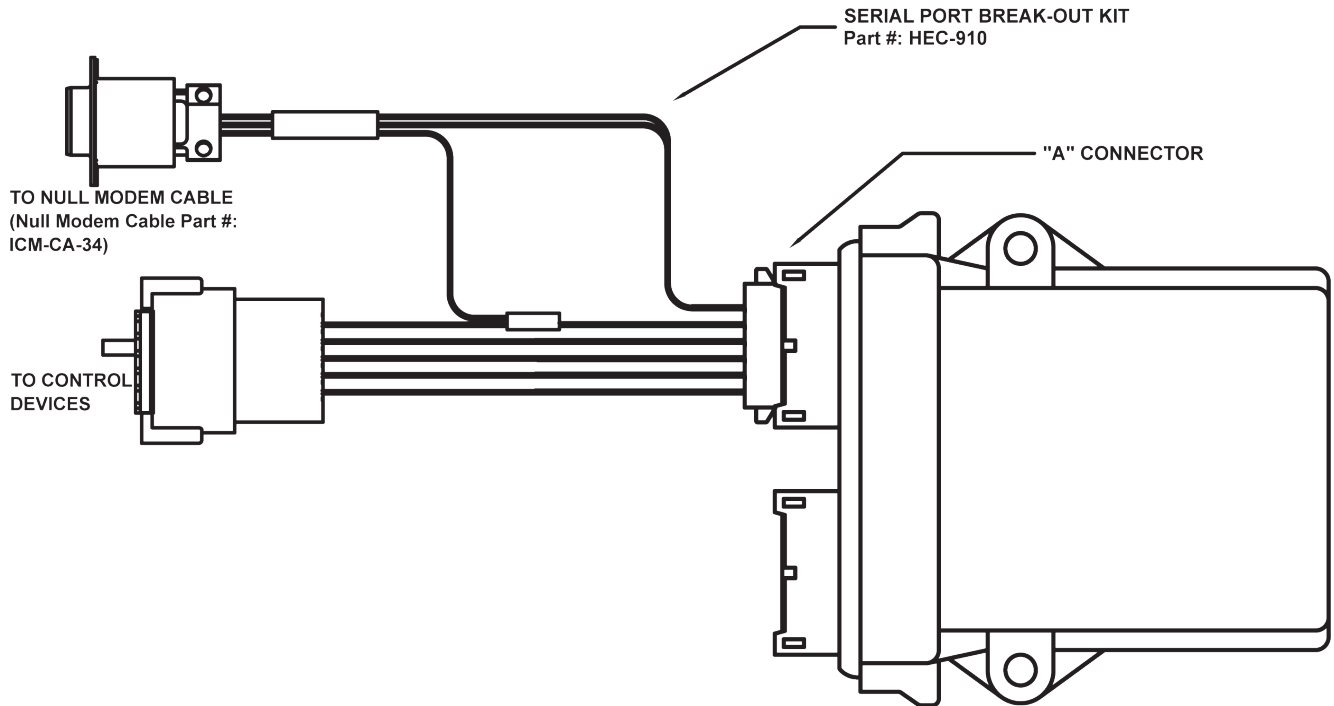

Figure 2.2 - Programming Port Break-out Connections

Watchdog LED



The operating status of the HEC-200x-E-R can be determined by the Watchdog LED. When the Watchdog LED is flashing at a slow rate, approximately once per second, then there is no ladder program executing. When the Watchdog LED is flashing at a fast rate (several times per second), a program has been loaded and it is executing.

If the Watchdog appears to be flickering at a very fast rate, the Kernel is not running. Either the kernel needs to be installed or the controller reset to restart the kernel if it is installed.

Should the Watchdog LED not flash at all, first check the input power. If the input power is correct and there is still no Watchdog LED, contact Divelbiss Technical Services.

Status LED

The HEC-200x-E-R provides a programmable status LED that can be seen from the front of the unit. This LED is programmed in the ladder diagram by using the STATUS variable that is automatically created when the target is selected.

Input Power



The HEC-200x-E-R may be powered using 8-32VDC. The input power must be of sufficient supply to drive the HEC controller and all the digital outputs (based on the load currents for each). Due to wire size limitations of the HEC-200x-E-R connectors, multiple input power pins are provided to allow for *parallel* input power lines to increase the amount of current (for heavier output loads). For an input power wiring diagram, refer to Figure 2.3.

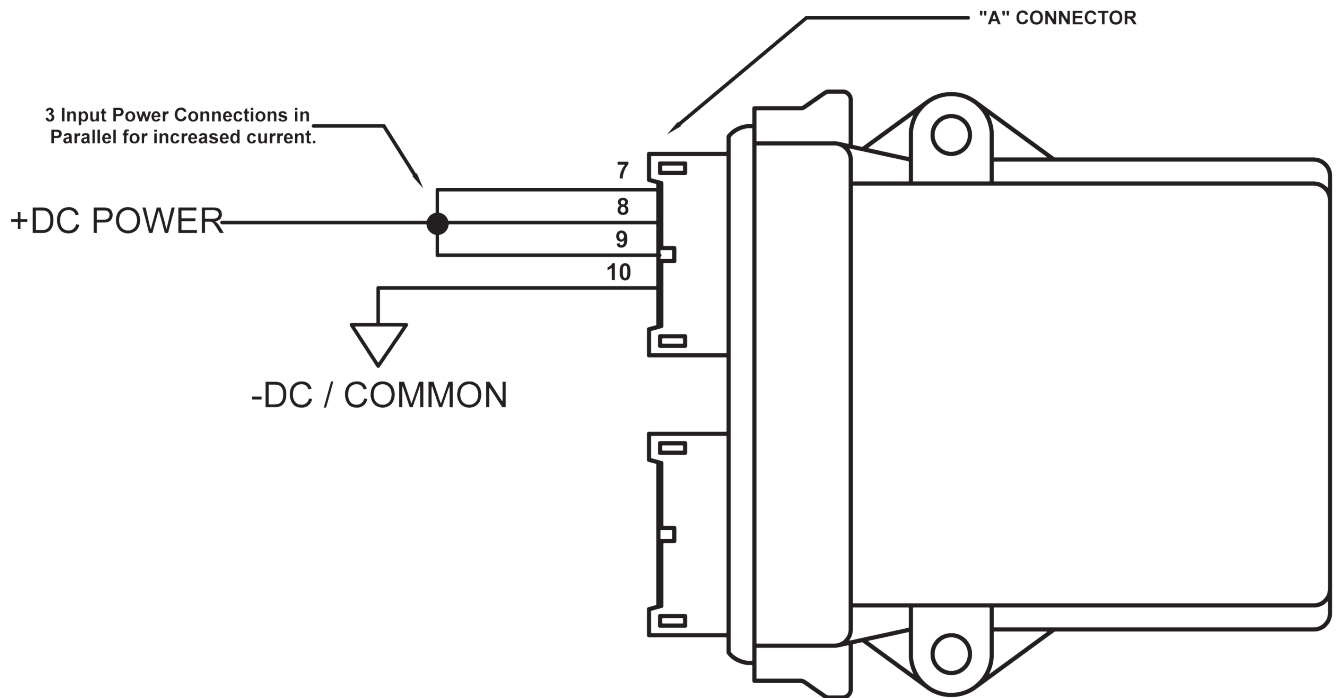

Figure 2.3 - Input Power Connections

Mounting

The HEC-200x-E-R mounts simply using two mounting screws. The HEC can easily accept mounting screws up to 1/4" in diameter.

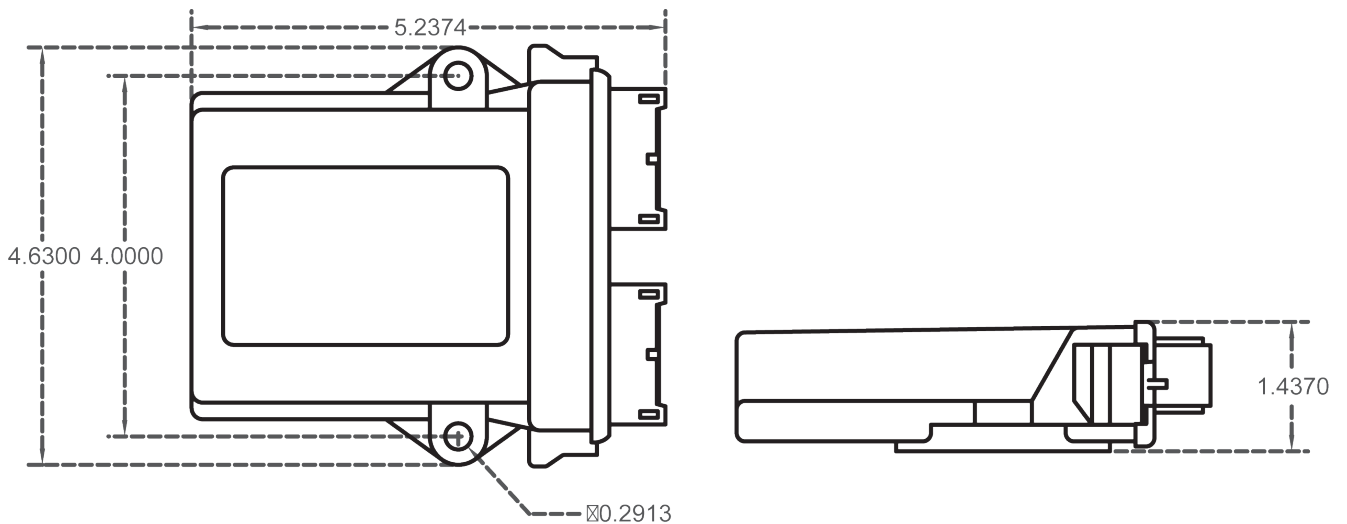



Figure 2.4 - HEC-200x-E-R Mounting

Digital Inputs

The HEC-100x-E-R includes 8 on-board digital inputs. They are identified in EZ LADDER Toolkit and this manual as GPIO through GPI7. Each digital input can accept an input voltage of 8-32VDC. The presence of this voltage on an input will result in the input being read as TRUE in the ladder diagram.

GPI6 and GPI7 may be used as general purpose digital inputs or high speed counters; while GPIO - GPI5 can only be used as general purpose digital inputs. For information on using GPI6 or GPI7 as high speed counter inputs, refer the COUNTER INPUTS Section of this User’s Manual.

To read a digital input status in a ladder diagram, place and connect the appropriate contact for your needs. The DIRECT CONTACT and INVERTED CONTACT functions are used to read digital inputs in the ladder diagram. When placing the contact, verify you select the correct input address (GPIO - GPI7) from the provided drop-down menu.

 It is important that the input device source be the same as the HEC-200x-E-R input power source as shown. Separate power sources could result in a damage to the controller if input power is lost, but the inputs are still powered. Refer to Figure 2.5.

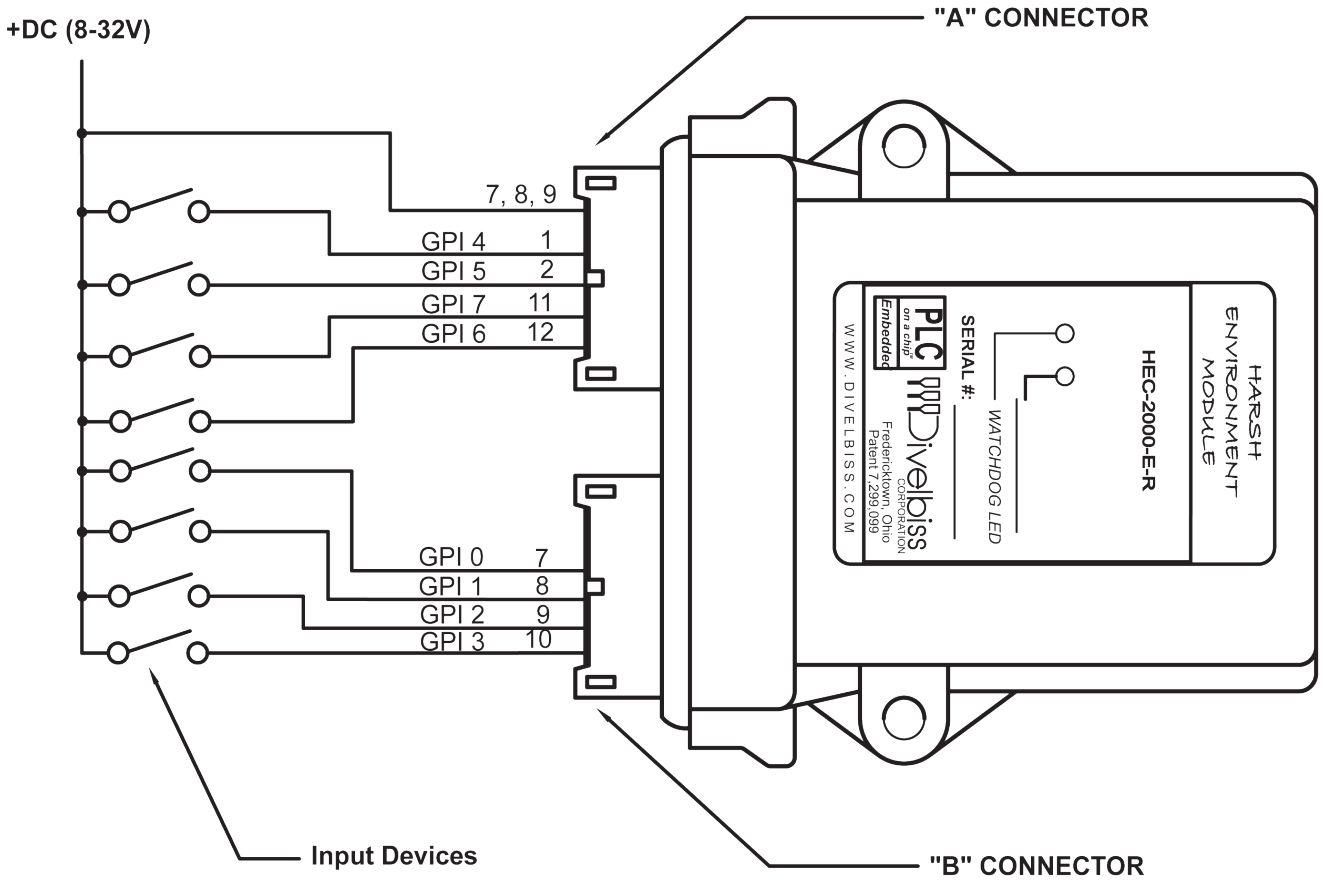

Figure 2.5 - Typical Digital Input Connections

Counter Inputs

As was noted in the Digital Inputs Section, two of the digital inputs (GPI6, GPI7) may be utilized as high speed counters (up counting only). These inputs will accept a maximum frequency of 40KHz and are optically isolated to promote noise immunity. These inputs are ideal to anywhere that high speed counting is required; such as calculating RPM, batch counting and more.



To use GPI6 or GPI7 in a ladder diagram as a high speed counter, you must use the CNTRMR function block. This block, when placed in the ladder diagram, will provide a drop-down menu to select which counter to use. Refer to the EZ LADDER Toolkit User's Manual for details on the CNTRTMR and other function blocks. GPI6 is Counter Channel 1 while GPI7 is Counter Channel 2 in the CNTRTMR function block.



Please note: Individually, the GPI6 and GPI7 inputs are designed to be used as a digital input only or high speed counter input only. EZ LADDER will allow the placement of contacts and /or CNTRTMR function in any program. Therefore, you can place and use the contacts and the CNTRTMR function block in the same program with the same digital input selected. This can be useful in some programs based on the application, but it is important to know that input contacts will only operate at a fraction of the frequency that the CNTRTMR function block can accurately read.

Typical High Speed Counter connections are shown in Figure 2.6.

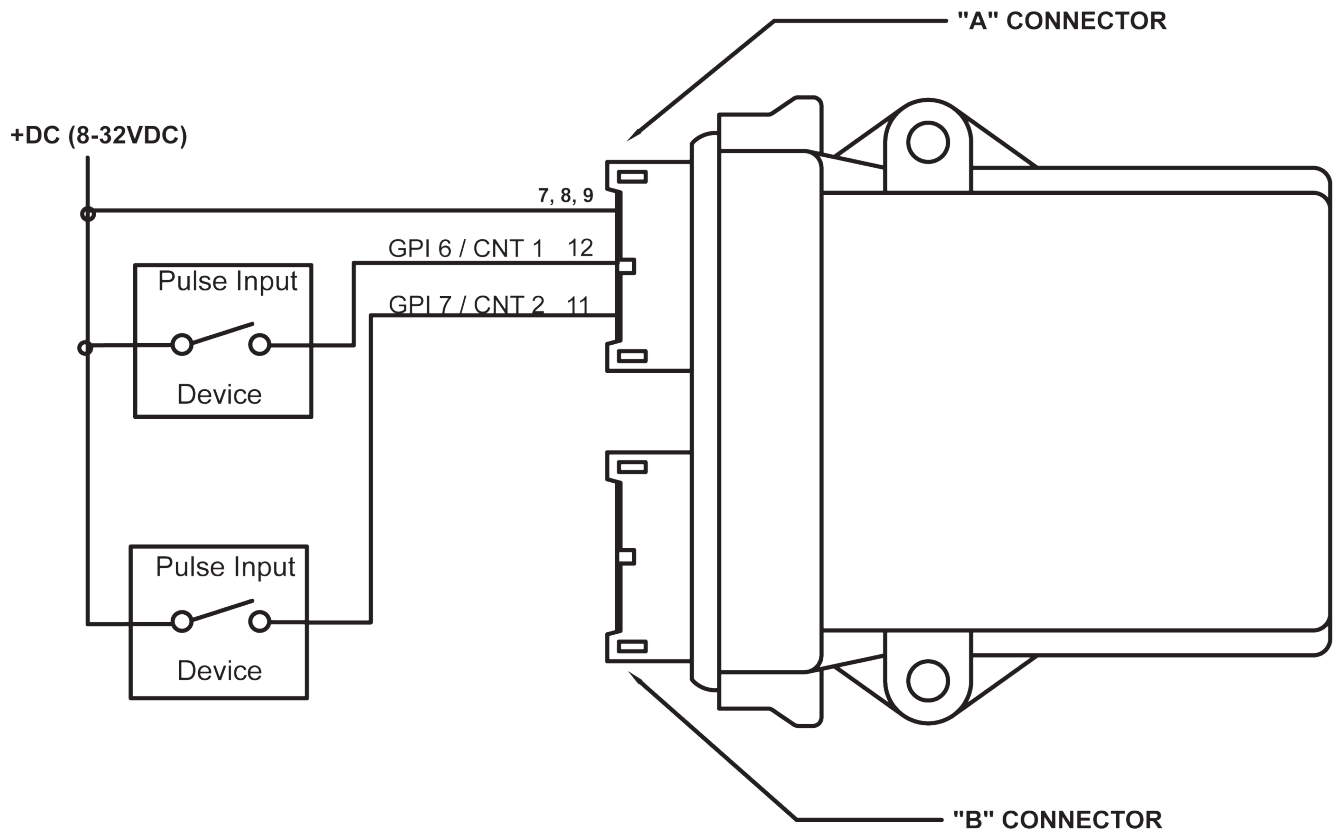

Figure 2.6 - Typical Counter Input Connections

Digital Outputs

The HEC-200x-E-R includes 8 on-board digital outputs. They are identified in the EZ LADDER Toolkit and this manual as GPO0 - GPO7. These outputs are sourcing, therefore an energized output will source an output voltage equal to the controller input voltage. Refer to Figure 2.7 for typical output connections.

Each output can drive a load up to maximum current rating listed in the specifications section (resistive) and includes an automatic over-current shutdown safety. In the event an over current condition exists, the output will shut down. This shut down condition is reset when the output is turned off (set to false) in the ladder diagram.



Each output requires a minimum load to operate correctly. Depending upon the device connected to an output, a minimum load resistor may be required. If the output is ON or true regardless of the ladder diagram program, connect a 470Ω to 1KΩ load from the output to input power common.

Each digital output may be configured and used as a digital output or as a Pulse Width Modulation (PWM). Each output may only be used as either digital output or PWM output only. For information on using digital outputs as PWM outputs, refer to the *Pulse Width Modulation Outputs* Section of this manual.



To control a digital output in a ladder diagram, place and connect the appropriate coil for your needs. The DIRECT COIL and INVERT-ED COIL functions are used to control digital outputs in the ladder diagram. When placing the coil, verify you select the correct output address (GPO0 - GPO7) from the provided drop-down menu.



In addition to controlling the outputs, the status of each digital output may be *monitored* for an OK or Fault status. When the HEC-2000 target is configured in EZ LADDER, 8 status variables are created automatically, identified (STAT0 - STAT7). These variables indicate the status of the output and may be used in the program as any boolean variable (DIRECT CONTACT or INVERTED CONTACT). A High or True condition indicates that the output is functioning properly while a Low or False condition indicates a fault condition of the output (open load or overload).

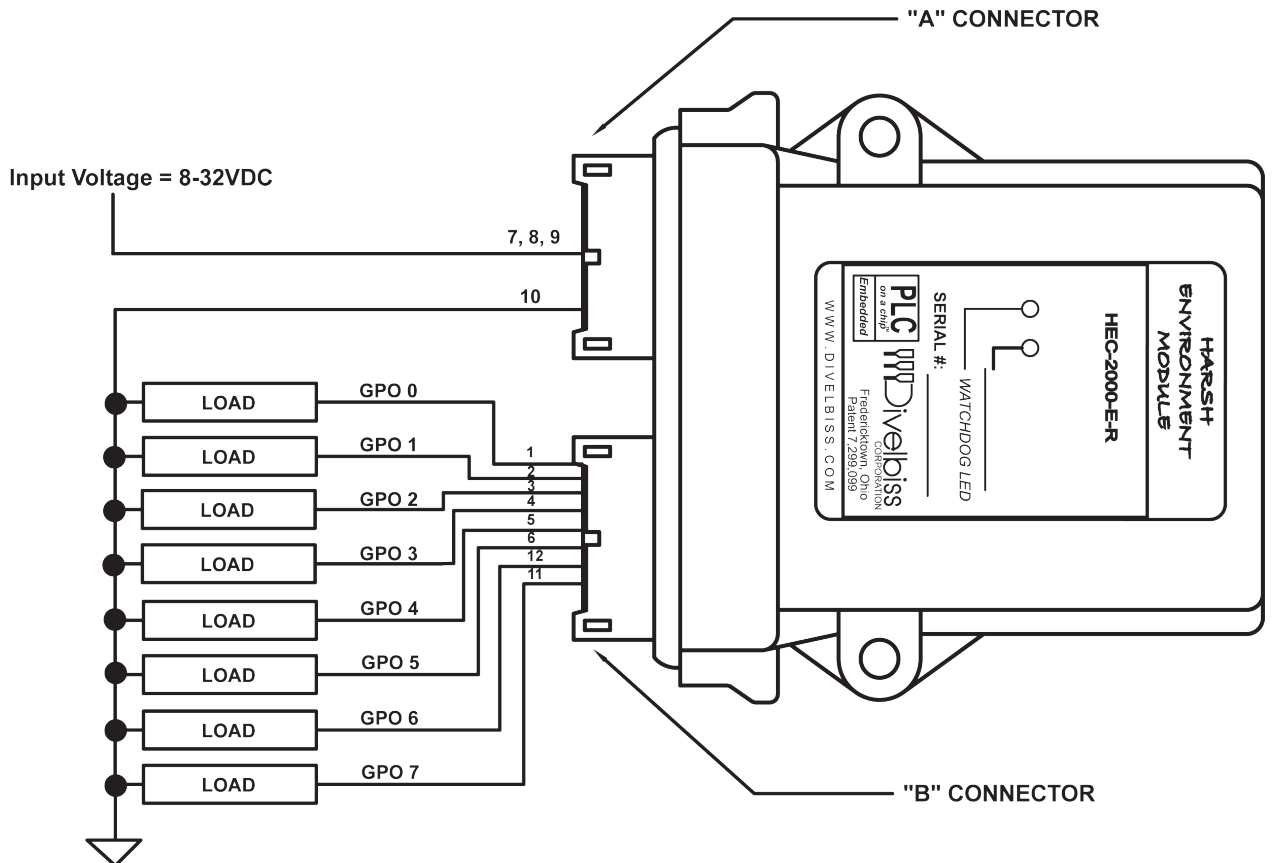

Figure 2.7 - Typical Digital Output Connections

Pulse Width Modulation Outputs

As previously noted, the HEC-200x-E-R includes 8 on-board digital outputs that may be configured individually and exclusively as either digital outputs or pulse width modulation outputs; therefore, each output may only be used as either digital output or PWM output.

Before Pulse Width Modulation outputs may be used in the ladder diagram, the Pulse Width Modulation Properties must be configured in EZ LADDER Toolkit.

To Configure Pulse Width Modulation (PWM) Outputs in EZ LADDER Toolkit:

1. In EZ LADDER, from the File Menu at the top, click **PROJECT** then **SETTINGS**. This will open the Project Settings Window. The HEC-2000 was previously selected.
2. Click the **PROPERTIES** button. The HEC-2000 Properties Window will open. Refer to Figure 2.8.

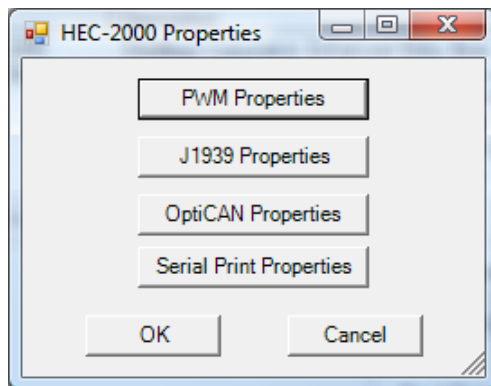

Figure 2.8 - HEC-1000 Properties Window

3. Click the **PWM PROPERTIES** button. The PWM Properties Window will open. Refer to Figure 2.9.

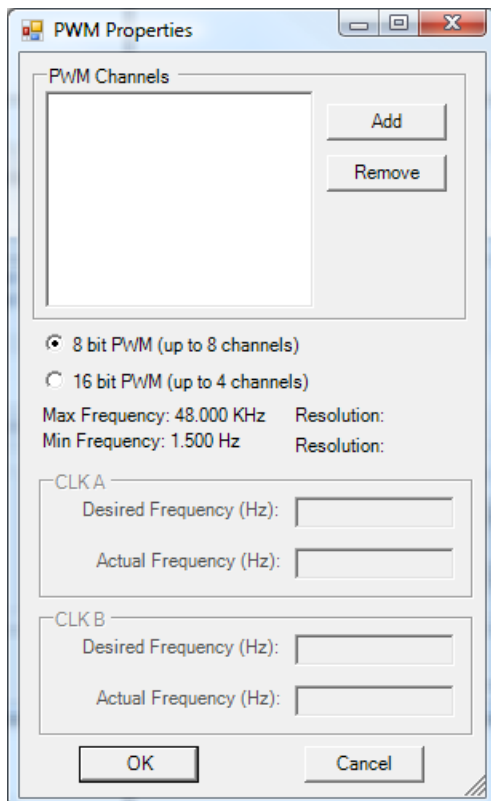

Figure 2.9 - PWM Properties Window



4. Select either 8-bit or 16-bit PWM Resolution. 8-bit allow for 8 channels (0-7), while 16-bit allows for 4 channels (1,3,5,7).
5. Click the **ADD** button in the PWM Properties window.
6. In the ADD PWM dialog, select the channels to install. To select multiple PWM channels, hold the CTRL key while clicking on the channel. Refer to Figure 2.10. Only available channels will be listed to be installed.

The channels are as follows:

| | | |
|--------------------------|--------------------------|-------------------------|
| Digital Output 0 - PWM 0 | Digital Output 3 - PWM 3 | Digital Output 6 - PWM6 |
| Digital Output 1 - PWM 1 | Digital Output 4 - PWM 4 | Digital Output 7 - PWM7 |
| Digital Output 2 - PWM 2 | Digital Output 5 - PWM 5 | |

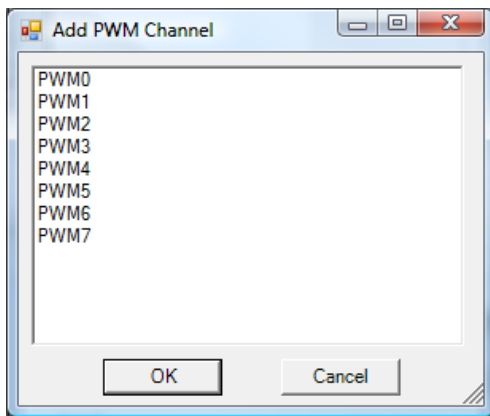

Figure 2.10 - ADD PWM Window

7. Click **OK** to close the ADD PWM dialog. The next step is configuring the frequencies.
8. Enter the desired frequency for Clock A and Clock B (if installed). The HEC has 6 available PWM Channels. These channels are either controlled with Clock A or Clock B. This allows two different PWM frequencies. The Minimum and Maximum frequencies are displayed in the PWM Properties dialog. The frequency for Clock A and Clock B must be in this range. Refer to Figure 2.9.



Due to limitations of hardware, the Desired Frequency and Actual Frequency may vary. The Actual Frequency will be the closest attainable frequency to the entered Desired Frequency.

9. Click **OK** to close the PWM Properties Window. Click **OK** to close the HEC-1000 Properties Window and click **OK** to close the Project Settings Window.



With the Pulse Width Modulation Outputs configured in EZ LADDER, they can now be used in the ladder diagram project. The PWM channel(s) are controlled in the ladder diagram by the PWM and PWM_FREQ function blocks. For each PWM channel required, a PWM function block is required. Typically, PWM Outputs operate at a set frequency while the Duty Cycle is adjusted to vary the output. The Duty Cycle is a variable input to the PWM function block. In the event the frequency must be changed during operation, the PWM_FREQ function block is used. Refer to the EZ LADDER Toolkit User's Manual for more detail regarding function blocks and variables.

Refer to Figure 2.11 for PWM channel connections.

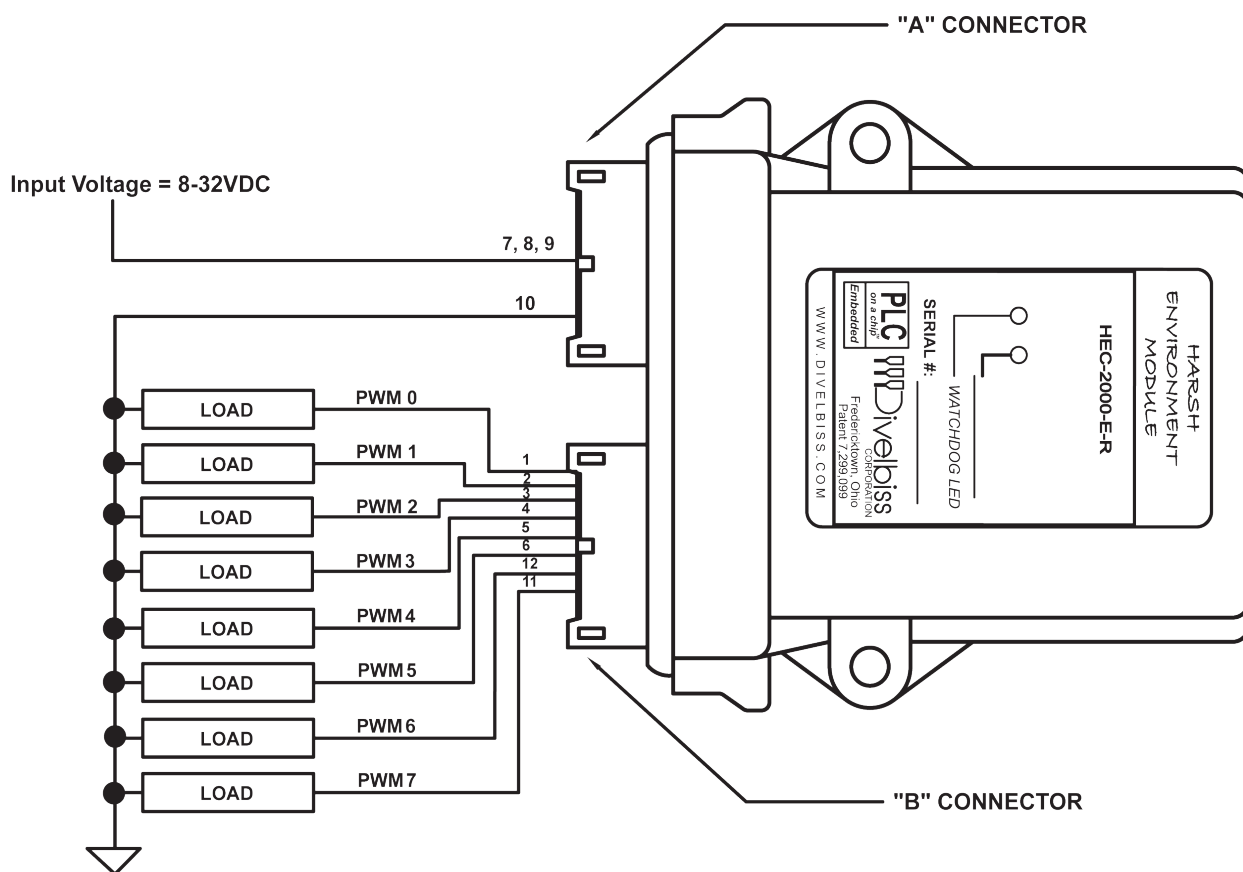

Figure 2.11 - Typical PWM Output Connections

General Purpose Serial Port - Models HEC-2001-2003-E-R

The HEC-200x-E-R optionally may be ordered with a second serial port. This serial port is a general purpose serial port that supports serial printing. This port may also be used to communicate to a Modbus Master Device (the HEC is a Modbus Slave). For Modbus details, refer to the EZ LADDER User's Manual and Modbus Supplement Document. At this time, the general purpose serial port is an output device only as there is no software support to read a serial input. As an output port only, this port can be used to transmit text and variables to an external device but cannot receive any data in return (unless using Modbus).

This port may be factory ordered as HEC-2001-E-R (RS232), HEC-2002-E-R (RS422) or HEC-2003-E-R (RS485). The general purpose serial port connection is achieved by a factory installed cable with an industry standard M8 connector. The HEC-2000-E-R does not have a general purpose serial port. Figure 2.12 illustrates the general purpose serial port cabling. For cable pin assignments, refer to Figure 2.13A.

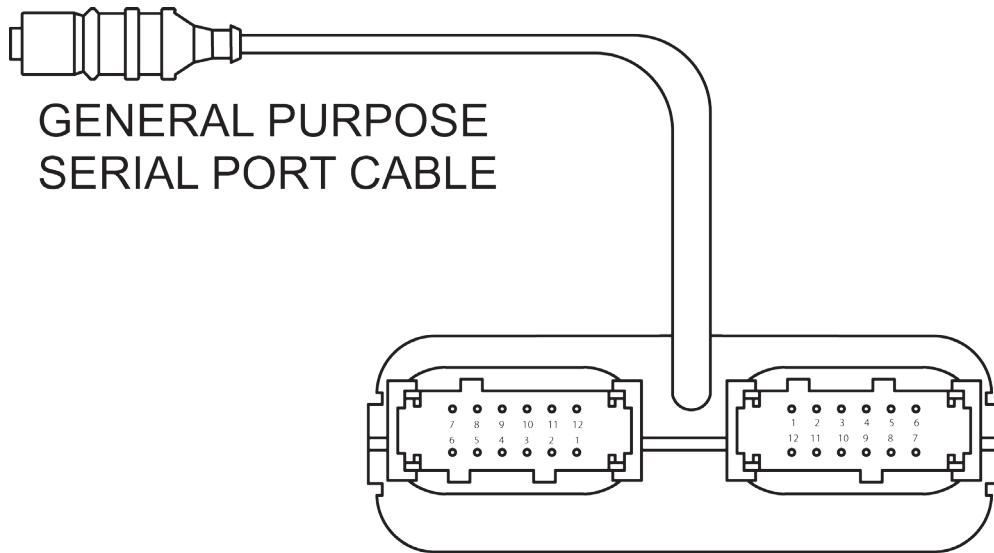
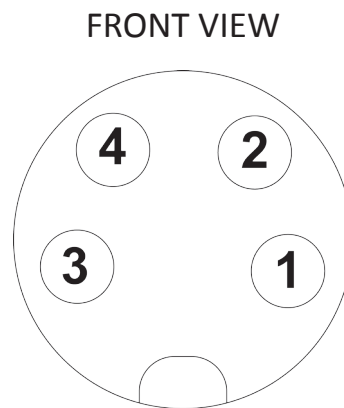

Figure 2.12- General Purpose Serial Port

| RS232 Serial Port - HEC-2001-E-R | | |
|----------------------------------|-----|-----------------|
| Pin | ID | Description |
| 1 | RX | Receive Data |
| 2 | TX | Transmit Data |
| 3 | GND | Ground |
| 4 | RTS | Request to Send |

| RS485 Serial Port - HEC-2003-E-R | | |
|----------------------------------|-----|-------------|
| Pin | ID | Description |
| 1 | TX+ | Data (+) |
| 2 | TX- | Data (-) |
| 3 | GND | Ground |
| 4 | -- | No Connect |

| RS422 Serial Port -HEC-2002-E-R | | |
|---------------------------------|-----|-------------------|
| Pin | ID | Description |
| 1 | RX- | Receive Data (-) |
| 2 | RX+ | Receive Data (+) |
| 3 | TX+ | Transmit Data (+) |
| 4 | TX- | Transmit Data (-) |



A connector cover for General Purpose serial port is available. Order using Divelbiss Part # 120-106189

Figure 2.13A - General Purpose Port Pin Assignments

General Purpose Serial Port - Models HEC-2004-E-R

The HEC-2004-E-R includes a factory installed field selectable RS232/RS422/RS485 serial port. This serial port is a general purpose serial port that supports serial printing. This port may also be used to communicate to a Modbus Master Device (the HEC is a Modbus Slave). At this time, the general purpose serial port is an output device only as there is no software support to read a serial input.

The general purpose serial port connection is achieved by a factory installed cable with an industry standard M8 connector. Figure 2.12 illustrates the general purpose serial port cabling. For cable pin assignments, refer to Figure 2.13B.

Based on the need of RS232, RS422 or RS485, the 4 pin M-8 cable assembly will differ. Follow the pin-outs for the type of interface required. Next, using the jumper assignments, configure the jumpers for either RS232, RS422 or RS485. The only remaining item is setting the type in EZ LADDER (Modbus or Serial Printing settings).

To configure the jumpers, it will be necessary to dis-assemble the HEC-2000 series controller. See Dis-Assembling the HEC-200x-E-R Controller section.

RS232 Serial Port - HEC-2004-E-R

| Pin | ID | Description |
|-----|-----|-----------------|
| 1 | RX | Receive Data |
| 2 | TX | Transmit Data |
| 3 | GND | Ground |
| 4 | RTS | Request to Send |

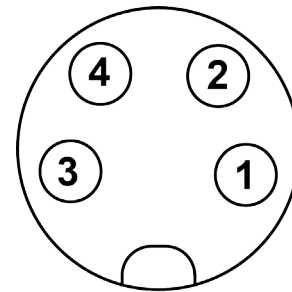
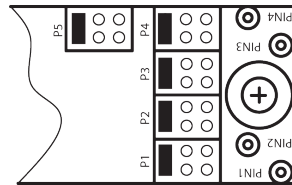

A connector cover for General Purpose serial port is available. Order using Divalbiss Part # 120-106189

RS485 Serial Port - HEC-2004-E-R

| Pin | ID | Description |
|-----|-----|-------------|
| 1 | TX+ | Data (+) |
| 2 | TX- | Data (-) |
| 3 | GND | Ground |
| 4 | -- | No Connect |

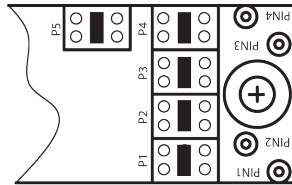

RS422 Serial Port - HEC-2004-E-R

| Pin | ID | Description |
|-----|-----|-------------------|
| 1 | TX+ | Transmit Data (+) |
| 2 | TX- | Transmit Data (-) |
| 3 | RX+ | Receive Data (+) |
| 4 | RX- | Receive Data (-) |

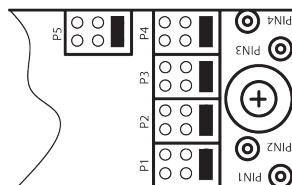

Serial Configuration Jumpers

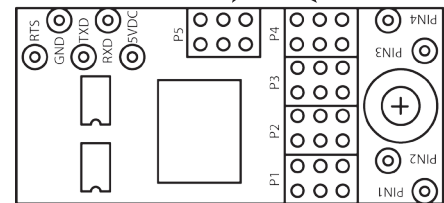

Internal Serial Board

Figure 2.13B - General Purpose Port Pin Assignments: HEC-2004-E-R

CAN Networking Ports

The HEC-200x-E-R provides one on-board CAN bus interface port. This CAN port may be used for additional communications and networking including SAE J1939 and the Divalbiss proprietary OptiCAN Network.

The on-board CAN port is CAN 0. To use the HEC's CAN ports as either SAE J1939 or OptiCAN, it will be necessary to configure certain parameters. These parameters may be configured from the HEC-2000 Properties Window in the Project Settings. As these settings vary greatly and are software based only, please refer to the EZ LADDER Toolkit User's Manual for details on configuring, using and implementing CAN port networking including all relevant function blocks.

The CAN ports should be wired according to established practices for CAN networks. Figure 2.14 illustrates typical CAN Port connections.

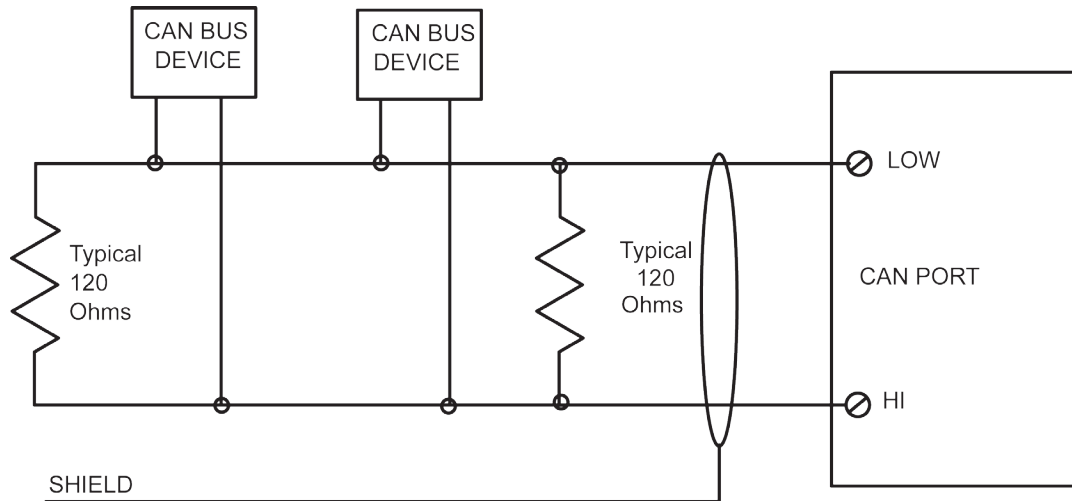

Figure 2.14 - Typical CAN Port Connections

HEC-200x-E-R Target Setting Options

To use some of the function blocks and features on the HEC-200x-E-R, it may be required to configure additional target properties in the Project Settings Dialog Box. Click **PROJECT** then **SETTINGS**. With the **HEC-2000** selected, click **PROPERTIES**.

The following are items that must be configured in the HEC-1000 Project Settings, Properties Dialog.

- PWM Properties** This is used to configure the Pulse Width Modulation channels (see *Pulse Width Modulation Outputs*).
- J1939 Properties** This is where SAE J1939 Communications is enabled and configured. Refer to the J1939 section of the EZ LADDER Manual.
- OptiCAN Properties** This is where OptiCAN Communications is enabled and configured. Refer to the OptiCAN section of the EZ LADDER Manual.
- Serial Print Properties** This is used if the Serial Print function block is to be used to transmit data to an external device using the General Purpose Serial port. The serial port is configured here.

Specifications

| | |
|----------------------|--|
| Processor: | PLC on a Chip™ |
| Memory: | 256K Flash, 12K RAM |
| Serial Ports: | 1 Programming Port (Max baud: 57.6K); 1 Multipurpose Port, Factory Configured as RS232, RS422 or RS485 (HEC-2001 to 2003 Models) 1 Multipurpose Port, Field Selectable as RS232, RS422 or RS485 (HEC-2004 Models). |
| Networking: | 1 CAN Port for Divelbiss OptiCan and J1939 Communications |
| Digital I/O: | 8 Inputs & 8 Outputs on-board, Expandable using OptiCAN Network Inputs rated 8-32VDC Outputs rated 4A Max ^{SEE NOTE 1} , Over-current protected. Output Voltage = Input Power |
| Counters: | 2 Channels, Count Up, 40KHz Max. (using Digital Inputs 6 and 7) |
| PWM Outputs: | 6 Channels 1.5Hz to 1KHz, Overcurrent Protected, Output=Input. 4ADC Maximum. See Note 1 Voltage, Sourcing rated at 4ADC Maximum. |
| Input Power: | 8-32VDC |
| Operating Temp: | -40-80° C ^{SEE NOTE 2} |
| Program Language: | Ladder Logic using Divelbiss EZ LADDER Toolkit. |
| Dimensions: | 4.63" Wide x 5.24" Length x 1.43" Tall. |
| Mounting: | Panel Mount using screws |
| Type: | Enclosed, Sealed Plastic Housing |
| Storage Temperature: | -40-85°C |

NOTE 1: 4ADC Total @ up to 50 ° C Maximum per 2 Output Channels. Channels paired as GPO0 / GPO1, GPO2 / GPO3, GPO4 / GPO5 and GPO6 / GPO7 Total Current is sum of both paired output channels. See Figure 2.15 for maximum output current per output channel pair based on ambient temperature.

NOTE 2: Operating Temperature is -40-80°C temperature rating for models without optional serial port (HEC-2000). For models with optional serial port, the standard operating temperature is -25 - 80°C. Full temperature range is available for serial port models., consult factory for delivery and price.

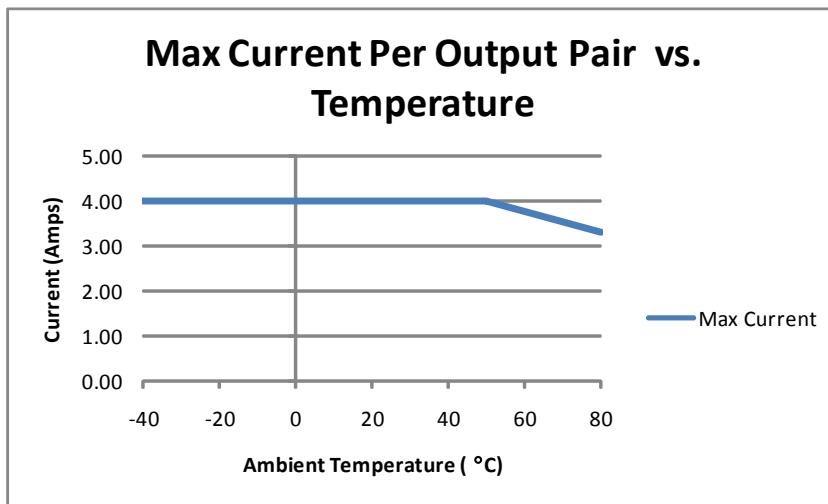

Figure 2.15 - Max Current for Outputs