

kogan

Muk# = V#U h°

USER MANUAL



Contents

- 1) Introduction
- 2) Specifications
- 3) Parts and Functions
- 4) User Instructions
- 5) Precautions
- 6) Packing List

1、 Introduction

1-1) Lighting Function

1-2) 1W powerful LED with optically-designed reflecting cup allows better lighting performance;
Adjustable lighting intensity.

1-3) USB output port allows mobilephone charging

1-4) 3 SOS LEDs

1-5) In-built dynamo allows self-charging by hand-cranking motion

1-6) AC-adaptor charging

1-7) In-built compass

2、 Specifications

2-1) LED lighting Power: 1.4W

2-2) Light Intensity ≥ 250 Lux /120mm

2-3) Light shooting distance ≥ 6 m

2-3) LED Life > 10000 hours

2-4) LED lighting Time:

Test Conditions	Continue lighting time
Battery fully charged (1300mAh)	≥ 500 minutes
When battery level decreased to a level that the lighting fades out/light intensity drops to 100LUX, and user hand-cranks it for one minute(speed ≥ 130 rev/min)	≥ 8 minutes

2-5) Mobile phone charging time:

Conditions	Phone Charging (iPhone battery used for reference)
Battery fully charged (1300mAh)	Could charge iPhone with 15-20% battery; iPhone talking time: 45-50 minutes
When battery level decreases to a level that the lighting fades out/light intensity drops to 100LUX, and user hand-cranks it for three minutes(speed ≥ 130 rev/min)	Could charge iPhone with 1% battery ; iPhone talking time: 3 minutes
When battery level decreases to a level that the lighting fades out/light intensity drops to 100LUX, and user hand-cranks it for three minutes(speed ≥ 130 rev/min)	Could charge Nokia 3100; Nokia 3100 talking time: 15 minutes

2-6) DC OUT : 5.0V (± 0.2) /400-500mA

2-7) Size: 205 x 80 x 72mm

2-8) Weight: 400g

2-9) Overall power of whole unit: 5W

2-10) Working temperature: -10°C ~ 40°C

2-11) Storage temperature: -20°C ~ 60°C

2-12) Rain resistant lighting ≥ 30 minutes

2-13) Battery specification: 3.7V/1300mAh Lithium Battery

2-14) Working Voltage: 3.0-4.2V.

3、 Parts and Functions (Pic 1)

1. Compass	4. Charging indicator	7. SOS LEDs switch
2. Top	5. Hand-crank	8. DC IN
3. LED	6. Light intensity knob	9. USB port

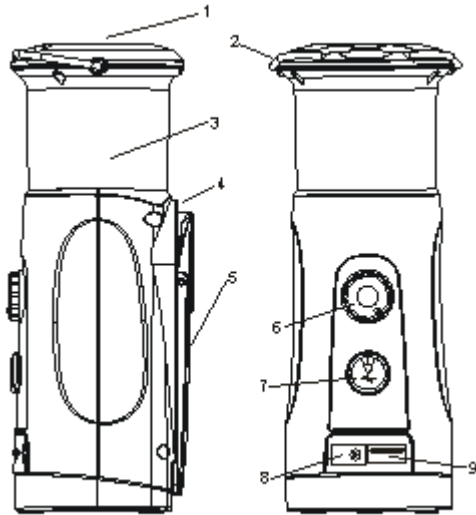

Pic1

4、 Users Instructions

4-1) Hand-cranking Part (Pic 2)

4-1-1) Take out hand-crack (5) from its position and flip 180°

4-1-2) Hand crank in a speed of 130-150 rev/min (either clockwise/anti-clockwise) (PIC 2)

4-1-3) While cranking, charging indicator (4) will light green. It shows the battery is being recharged.

4-1-2) If hand-cranking speed is less then 130 rev/min, charging performance will be worse.

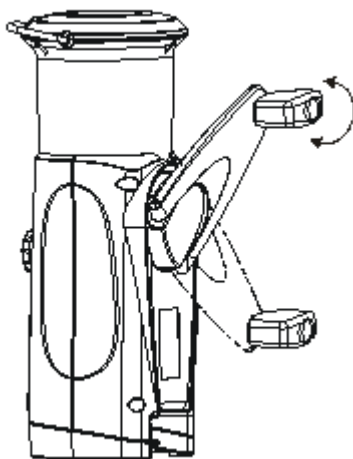

Pic 2

4-2) Lighting Function:

4-2-1) Turn light intensity knob (6) clockwise to switch on the lighting. Turn light intensity knob (6) further clockwise for brighter lighting and vice versa. (Pic 1)

4-2-2) Turn light intensity knob (6) anti-clockwise till a 'tick' sound gives out to switch off the lighting function.

4-2-3) When light goes dim, please hand crank the product for better lighting functionality.

4-3) SOS lighting and cell phone charging function:

4-3-1) Press the SOS LED Switch (7) once for switching on the SOS LEDs. Press the SOS LED Switch (7) twice to switch on the USB output function and the charging indicator (4) will light up green at the same time.

4-3-2) Connect your mobile phone per below diagram (Pic 3) and your phone could be charged under this mode.

4-3-3) Press the SOS LED switch (7) again to switch off the mobile phone charging function and the charging light (4) will turn off at the same time.

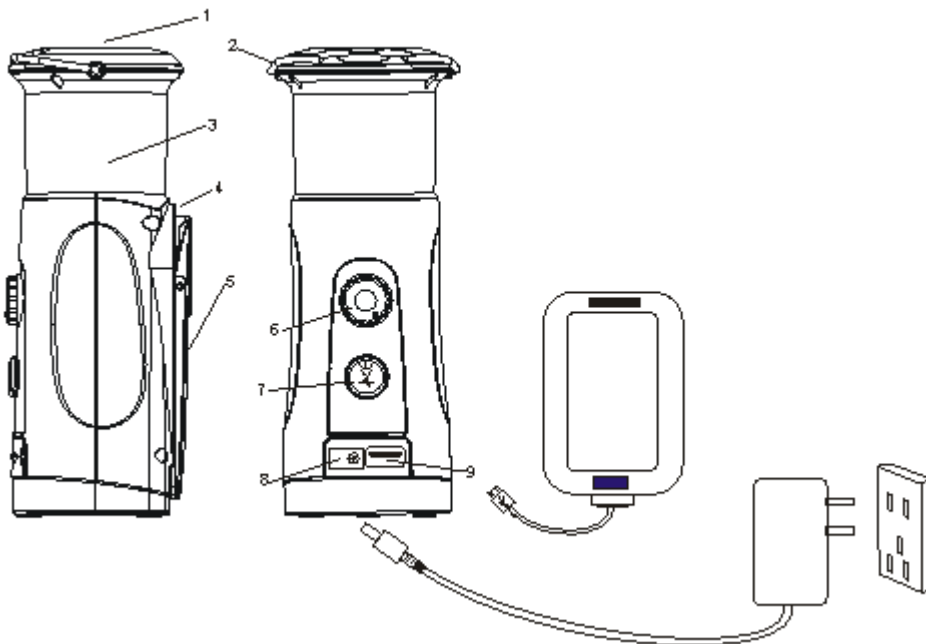

Pic 3

5、 Precautions:

5-1) For first time use, or if the lamp has not been used for more than 60 days, users need to hand-crank the handle for 3-5 minutes to re-activate the battery.

5-2) Please securely cover the USB charging plug with the rubber cover when not in use.

5-3) Do not expose under prolonged sunlight. Keep it in moderate temperature.

5-4) Do not use chemical solvent/detergent to clean the lamp surface. Clean it with dry towel.

5-5) Do not shoot light into eyes.

5-6) Do not unscrew any of the screws, or the torch may not function correctly.

5-7) Please follow this instruction manual.

6、 Packing List

6-1) One lantern (MT-201)

6-2) Packing Box