

# DL02

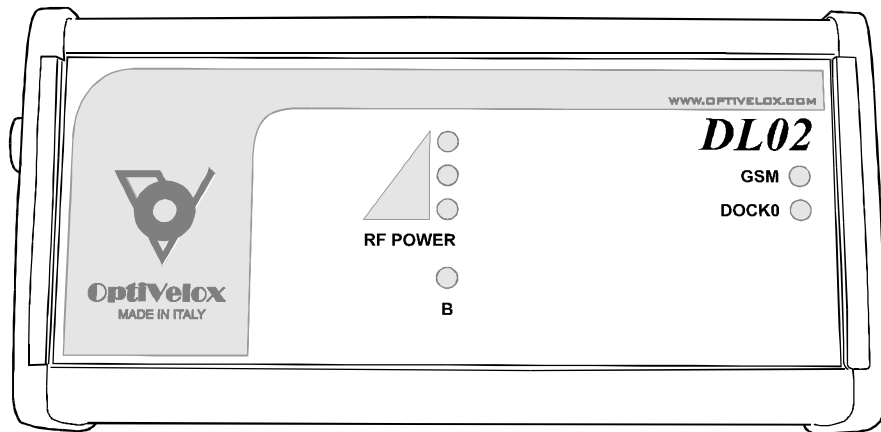

## TABLE OF CONTENTS

INTRODUCTION .....	p. 4
1. WARNINGS.....	p. 6
1.1 Warranty	
2. GETTING STARTED.....	p. 7
2.1 Front panel	
2.2 Left panel	
2.3 Right panel	
2.4 Basic configuration	
2.5 Wired configuration with FE01/02	
2.6 Wired configuration with FE03/04	
2.7 Mixed configuration	
3. USING THE DATALOGGER.....	p. 12
3.1 Quick guide	
3.2 Operating logic	
3.3 Description of the operating states	
3.4 Hints and tips	
3.5 Charging the battery of a node	
4. MAINTENANCE, DOCUMENTATION AND ACCESSORIES...	p. 18
4.1 Replacing the battery clock	
5. TECHNICAL SPECIFICATIONS.....	p. 19
APPENDIX A: Dataget	
APPENDIX B: FE01	
APPENDIX C: RM01	
APPENDIX D: CB01	
APPENDIX E: FE02	
APPENDIX F: FE03	
APPENDIX G: FE04	
APPENDIX H: INT11	
APPENDIX I: FE03H	
APPENDIX L: FE04H	
APPENDIX M: GSM module	
APPENDIX N: IV01	

## INTRODUCTION

The DL02 unit is a high performance datalogger, designed to operate in a wireless network. The datalogger communicates with one or more measurement nodes, equipped with appropriate sensors. Each device has a radio modem operating according to the ZigBee standard; the communication takes place via a star network (denominated DataZig) in which DL02 is its center. The sensor data are sent from the measurement nodes to the datalogger and recorded on its non-volatile memory. At any time the data can be collected from DL02 to a PC using a standard USB interface.

Depending on the type of measurement, the network can use different types of radio modems (RM01, RM01-P) which are interchangeable and differs only for RF power transmission. Each modem is individually powered by a rechargeable internal battery. The autonomy depends on the sampling frequency of the node and can allow up to several months of continuous operation. Recharging the battery takes place within a couple of hours by placing the radio modem in the docking provided by the datalogger (DOCK0).

Thanks to the wireless communication is possible to perform measurements of various physical quantities providing galvanic isolation and avoiding any issue concerning ground loops.

The sample time of the data transmitted by a measurement node can be selected in a range of 1...65365 s). Each node consists of a radio modem and a signal conditioning device (FE01 or FE02 family) which are connected physically to the measuring sensors. In addition to the wireless nodes, DL02 can support simultaneously devices communicating via RS485 serial thereby increasing the versatility of the system. The data sent from each measurement node are received by DL02 and synchronized to its internal clock with a resolution of 0.1 s.

There are various models of FE01/02; everyone can manage one or more independent channels allowing for the measurement of physical quantities of different kinds.

The datalogger automatically recognizes the type and magnitude of measurement, and it does not require any manual operation. You can add up to 30 measurement nodes to the network.

The following drawing shows an example of a DataZig network composed by four measurement nodes:

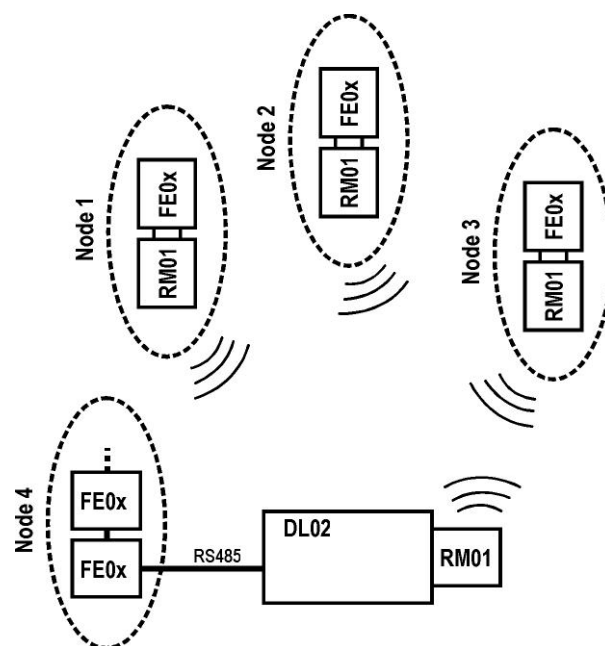

The minimal configuration consists of a DL01 unit equipped with a radio modem (connected to DOCK0) and a measurement node (consisting of a radio modem device and a signal conditioning front-end). Alternative configurations with wired or mixed connections are also possible as shown in detail in Chapter 2.

## APPLICATIONS

The typical application of DL01 is a measurement where it is required to record data with sampling times comprised between 1 and 65535 s.

Examples of possible applications:

- Temperature measurements.
- Thermal flux measurements.
- Humidity measurements.
- Redox, PH measurements.
- Irradiance measurements.

The type of physical quantity to be measured is elaborated by the conditioning signal FE0x inside each measurement node. The DL01 unit receives data from nodes in a standard digital format. Consequently, the datalogger DL01, without modification, will be able in future to broaden the range of physical measures as soon as new FE0x devices become available.



*Notes and comments.*



*Tips for using the equipment most effectively.*



*Operation that may compromise the integrity of the measured data and/or damage the equipment.*

## 1. WARNINGS



Before installation or using the equipment, please read carefully the instructions in this manual.

The manufacturer believes that the information in the manual is sufficient to ensure the proper use of equipment and personnel safety. It is the responsibility of the users to ensure that all instructions are followed before powering up the unit.

- **Connect the instrument following the instructions of this Manual.**
  
- **The instrument contains a backup battery for internal clock. Do not expose the equipment to liquid or high humidity.**
  
- **There are no user settings that can be performed inside the unit. The opening of the enclosure is required only for the replacement of the battery (last about 10 years). The opening of the unit will void the warranty.**

### 1.1 Warranty

All the equipment described in this manual are warranted against defects in materials and workmanship for a period of one year.

During the warranty period, Manufacturer will, at its option, either repair or replace products which prove to be defective. The warranty period begins on the date of shipment.

For warranty service or repair, this product must be returned to Manufacturer. For products returned to Manufacturer for warranty service, the Buyer shall pay for shipping charges.

The foregoing warranty shall not apply to defects resulting from improper or inadequate maintenance by the Buyer, unauthorized modification or misuse, or operation outside of the environmental specifications for the product. Unauthorized modification includes disassembly of the hardware or removal of any part of the hardware. The design, construction, and measurement of any system by the Buyer is the sole responsibility of the Buyer. Manufacturer does not warrant the Buyer's system, products, or malfunction of the Buyer's system or products. In addition Manufacturer does not warrant any damage that occurs as a result of the Buyer's system, product, or the Buyer's use of Manufacturer products.

## 2. GETTING STARTED

The typical setup of a complete acquisition system comprises a wireless DL02 datalogger, two or more radio modem RM01 (one for each measurement nodes plus one for the datalogger itself) and one or more FE01/02 front-end. The measurement nodes can vary from a minimum of 1 to a maximum of 30. Besides that, FE03/04 can additionally or alternatively be connected in wired mode (without RM01). The technical description of each device is given in the corresponding appendix of this Manual.

This chapter describes the warning lights, sockets and switches on the DL02 units. For more details about their meanings please consult the following chapters.

### 2.1 Front panel

The front panel of DL01 unit is shown in Fig.2.1:

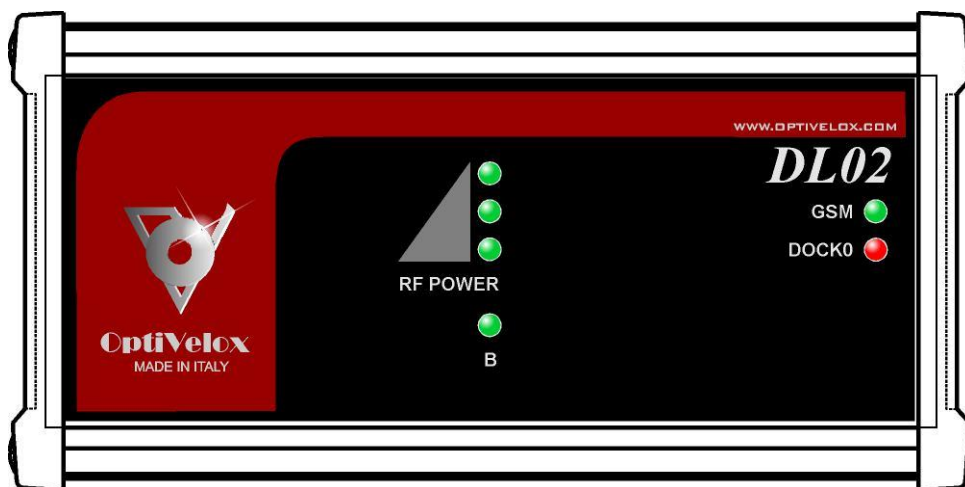

**Fig.2.1** – DL02 front panel

Where:

#### **GSM**

Green indicator; activity of the GSM modem. For details see appendix L dedicated to the GSM communication management.

#### **DOCK0**

Red indicator; used to highlight the activities of the battery charger. For a detailed description see Par.3.5.

#### **RF POWER**

This signaling group is composed by three green LEDs intended to indicate the power of the RF signal received from the radio modem. The purpose of this power meter is to give an immediate indication about the reliability of the wireless link. The indication is activated immediately after a data packet is received and is maintained for about half a second. It is recommended to operate with a RF power signal sufficient to turn on at least one LED.

The RF power monitor is coded as follows:

- All LEDs turned off: insufficient level (< 10 db fade margin)
- 1 LED turned on: weak level (> 10 db fade margin)
- 2 LEDs turned on: good level (> 20 db fade margin)
- 3 LEDs turned on: very good level (> 30 db fade margin)



*In the presence of a network of wired-only devices (no wireless modem), each time a data packet is received all three LEDs are lit for a short time.*

## B

This indicator consists of a bi-colored LED and is used to indicate the operational status of the instrument. For the details about the color code and the corresponding meaning please see the chapter dedicate to the operating states.

## 2.2 Left panel

In the left side panel, as shown in Fig.2.2, there are:

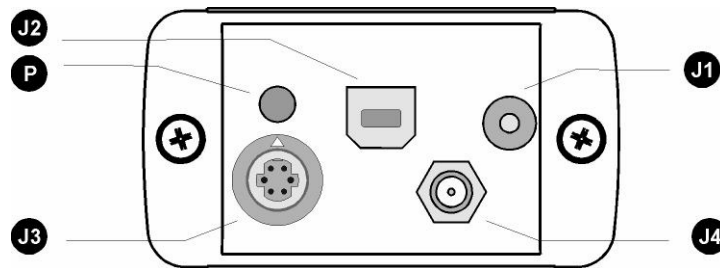

**Fig.2.2** – DL02 left panel

## P

The P button is used to send operating commands to the instrument as described following in the instructions for use. The activation of the button is usually accompanied by a beep of the internal buzzer (a single beep for quick activation, a double beep for prolonged activation).

## J1

Socket for the power supply (external power). Requires a standard coaxial jack with center positive (hole diameter = 2.5 mm). The voltage should be within the limits reported by the technical specifications.

## J2

Socket for USB interface. It requires a connector compatible with the receptacle Type-B. As an alternative to external power via J1 socket, the device can be powered directly by USB cable.

## J3

The J3 connector (optional) provides a bus link RS485 compatible with Front-End FE03/04 family. The connector carries the digital signals and the power supply sufficient to handle up to 16 devices simultaneously connected.

**Circular connector pinout:**

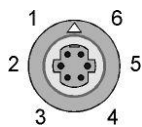

- 1. Vs
- 2. A (RS485)
- 3. 0V
- 4. 0V
- 5. B (RS485)
- 6. -

**J4**

SMA female connector (optional) for connecting external GSM antenna. The antenna must be suitable for operating in the 900 MHz and 1800 MHz bands.

**2.3 Right panel**

The right side panel (Fig.2.3) has a slot for RM01 modules (DOCK0). The housing consists of a DB9 male connector through which the radio modem can be powered and exchange data with the unit. Through the same connector, a special charger inside the datalogger is able to recharge the internal lithium-polymer battery of the radio modem.

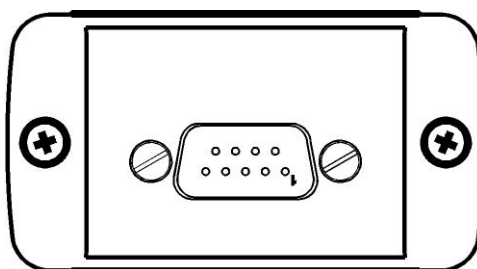

**Fig.2.3 – DL02 right panel**

**2.4 Basic configuration**

The system can handle from 1 to 30 measurement nodes; the basic configuration uses a single node. In this particular case the necessary arrangements to implement the configuration are as follows:

- DL02
- RM01 (two)
- FE01

The configuration is schematized in Fig.2.4:

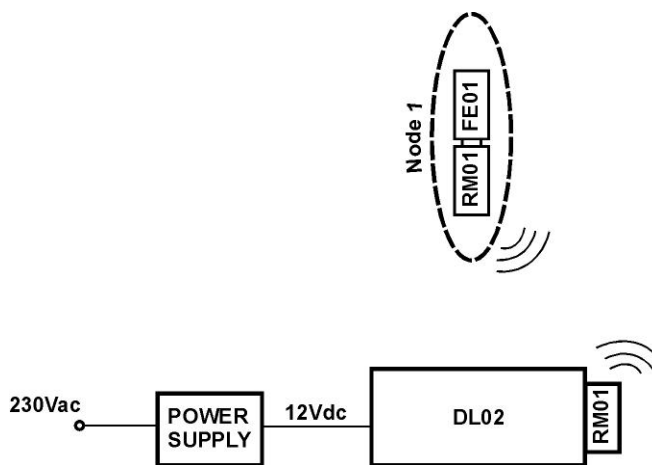

**Fig.2.4 – Basic configuration**



The complete setup of the system involves the following steps:

- 1) Insert a radio modem RM01 into DOCK0 with DL02 not powered.
- 2) Turn on the DL02 unit and make sure that the B indicator is green colored (if B was red then first press P for a single beep to get the yellow light and then P for a double beep so to get the green light).
- 3) Place the sensors connected to FE02/02 to the desired location, possibly using fixing pastes or adhesive tapes.
- 4) Connect the radio modem RM01 to FE01/02.
- 5) Make sure that the node is recognized by the DL02 (single beep and B light yellow).
- 6) Verify that the RF signal level is high enough making sure that at the reception of a data packet at least one LED of the power RF meter will light on. In order to evaluate the RF signal level just press P for a single beep and look at the power meter; after pressing P each node of the network send a test packet than can be used to check the wireless link.  
To improve the quality of the signal you can change the position of DL02 or the orientation of the Antenna so to maximize the power read.

In the case where the system has multiple measurement nodes, you should repeat steps 3, 4, 5 for each node.

Upon completion of the setup, a recording session can be easily started with a quick activation of P (see the following chapter for more detail about it).

## 2.5 Wired configuration with FE01/02

For short range measurements, you can avoid using the radio modem and connect a FE01/02 device to the datalogger through the INT08 interface. Note that with this setup you can manage only a single measurement node.

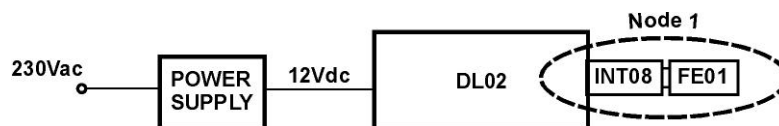

**Fig.2.5** – Wired configuration with FE01

This setup involves the following steps:

- 1) While DL02 is turned off insert the INT08 to DOCK0 e connect FE01/02 to INT08.
- 2) Turn on the DL02 unit and wait until the B indicator becomes yellow (if B is red you must stop recording, turn off the power and repeat from step 1).

Upon completion of the setup, a recording session can be easily started with a quick activation of P (see the following chapter for more detail about it).

## 2.6 Wired configuration with FE03/04

You can avoid using the radio modem and connect a FE03/04 directly to the datalogger via the J3 connector. Unlike the previous configuration, in this case multiple FE03/04 devices can be daisy-chained; with the advantage of being able to significantly increase the number of channels managed (Fig.2.6).

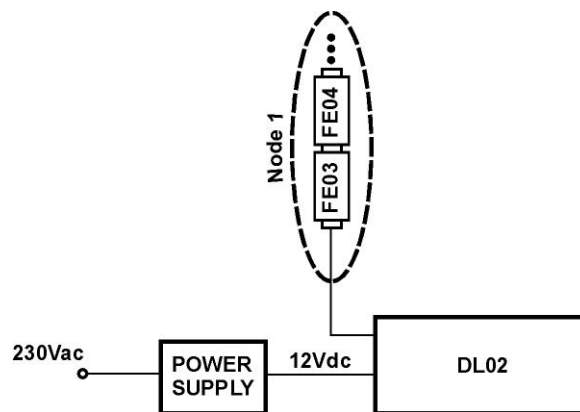

Fig.2.6 – Wired configuration with FE03/04

This setup involves the same steps described in the previous paragraph (Par.2.5).

**2.7 Mixed configuration**

This is the most general configuration, in which the network is formed by one or more wireless nodes wireless plus a node directly connected to the datalogger via the J3 connector.

To prepare this setup just connect the wired node to the datalogger with DL02 turned off and then proceed as described from step 2 of Par.2.4

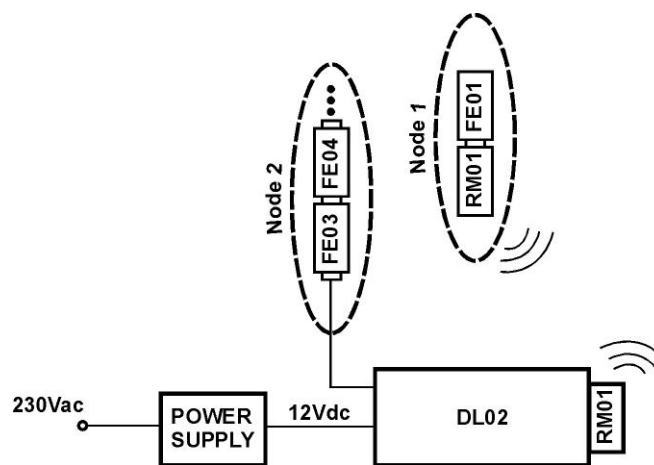

Fig.2.7 – Mixed configuration

### 3. USING THE DATALOGGER

At the end of the steps described in the previous chapter, DL02 unit is ready to enter in recording mode and save the data into the internal non-volatile memory. This condition (READY) is marked by a yellow light on the B indicator.

#### 3.1 Quick guide

DL02 unit enters in recording mode (REC) after a prolonged activation of P (double beep). During the registration phase the indicator B becomes red.

You can pause the recording by pressing briefly P (single beep) and then resume it by pressing P again for a single beep. Note that PAUSE mode is indicated by B blinking yellow.

Once the acquisition phase is completed you can stop the recording mode. Registration ends after pressing P for a double beep while DL02 is in PAUSE mode, returning to the initial configuration (B turns on green). Note that if the power supply is removed from DL02 during the recording phase, it will resume automatically the recording session when turned on again.



*After finishing a recording session and be returned to initial state, be careful not to start a new recording session or you can loose the last recorded session. Before starting a new recording session you need to download the data from the last session from DL02 to a PC using the software Dataget.exe (described in Appendix A).*

If you want to make a new recording session, you can wake up all nodes in the network by a prolonged activation of P while the datalogger is in assignment state (ASSIGN). Note that the nodes employing FE01 devices do not have the ability to wake up automatically and must be disabled and re-activated manually.

#### 3.2 Operating logic

The functioning of the equipment is based on a series of operations grouped conceptually in a number of "states". Each state performs a specific task, the transition from one state to another occurs automatically when the previous task has ended or using the P button as shown by the diagram in Fig.3.1:

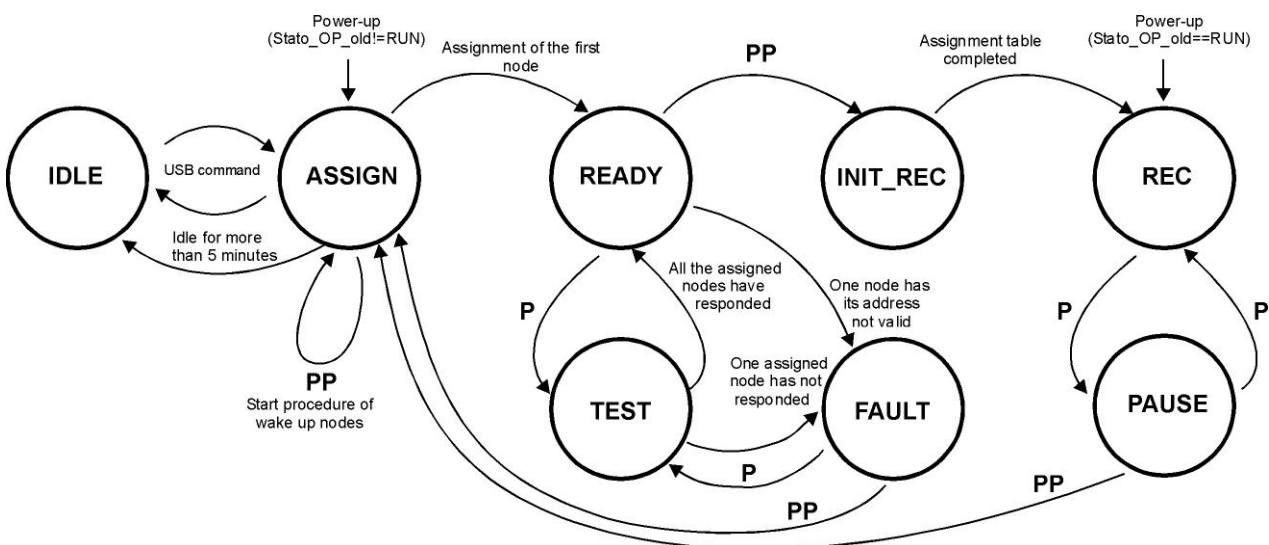

Fig.3.1 – State diagram

Where:

- P: quick activation of the button ( $0.1 \text{ s} < t < 1.5 \text{ s}$ ), indicated by a single beep.
- PP: prolonged activation of the button ( $t > 1.5 \text{ s}$ ), indicated by a double beep.

### 3.3 Description of the operating states

#### IDLE

The unit operates just handling the USB connection without communicating with the measurement nodes. You enter this state with a particular command sent from the PC via USB or after a prolonged period of inactivity during the ASSIGN state.

Indicator B: normally off, green pulse on data received from USB, red pulse on data received from the radio modem.

#### ASSIGN

This state represents the initial state of the operation. During this state the instrument waits for the activation of the first measurement nodes (ie the physical connection RM01-FE01). When a node is activated it transmits a special data packet to DL01 that responds sending a statement of acknowledgment to the node. Then the node responds with the string "OK" and ceases to send further packets. DL02 recognizes the string "OK" with a beep and switches from the ASSIGN to READY.

Indicator B: green.



*The datalogger goes into IDLE state and turn off the radio modem if the ASSIGN state persists for longer than 5 minutes (the transition is marked by a triple beep). The purpose of this function is to save energy when the unit is used only to recharge the battery of the radio modem.*

After a recording phase has finished, the datalogger will return to ASSIGN state, however, the nodes remain in their state of RUN (for more details see the description of FE01/02 in the appendix). In order to restore the initial state of the network all the nodes must be awakened. The awakening of a measurement node can be done by unplugging the radio modem. The newer FE02 devices since v.2.3 release support also the remote awakening. In this case a prolonged action of the button of the datalogger (PP) wakes the nodes and forces them into the initial state of POLLING.

#### READY

The unit is in this state when at least one node of the network was recognized and assigned to the measurement network; the datalogger is ready to enter into registration mode. If another measurement node is activated, the new information data are added to the internal assignment table so to update the composition of the network. Each new node activation is recognized by the datalogger with a beep.

Indicator B: yellow.

#### TEST

During this state the unit scans the measurement nodes in order to have a confirmation of the proper assignment. One by one, the nodes already assigned within the network are interrogated. Each queried node responds with the string "OK ". The order of interrogation comply with the order of assignment (i.e., the order in which the nodes were turned on). At the end, if all nodes have responded correctly, the datalogger returns to the READY state, otherwise if at least one node has not responded it switches to the FAULT state. The unit sends a beep for each response received from a node.

The details about the response of each node can be viewed with the Monitor function of the Dataget program.

Indicator B: blinking green.

### FAULT

The unit gets into this state if there is at least one node correctly assigned to the network, but during the TEST routine it doesn't respond. Before entering in recording mode make sure that the power of the RF signal is high enough (use the TEST routine, moving if necessary the datalogger or changing the alignment of the antenna).

Indicator B: slow blinking red.

### INIT\_REC

The allocation table, containing information about the current composition of the network, is saved on the internal flash memory. Each activated node receives from the datalogger the command to enter into RUN state (see detailed description of the device FE01/02).



*DL02 fails to enter into REC state if at least one node of the the allocation table does not respond to the run command. In this case the unit goes into ERROR state.*

Indicator B: fast blinking yellow.

### REC

The data from the measurement nodes are stored in the flash memory of datalogger.

Indicator B: red.

### PAUSE

The recording session is suspended, the data from the nodes are received but not saved into the datalogger's internal memory.

Indicator B: slow blinking yellow.

### ERROR

One of these errors occurred:

- 1) Communication error with the internal clock (RTC)
- 2) Radio modem DOCK0 not present or not functioning properly
- 3) At least one node has failed to enter in RUN mode (during INIT\_REC state)
- 4) Flash memory full (linear recording mode only)

In this case, switch off the datalogger and try to eliminate the cause before turning it on again.

Indicator B: fast blinking red



*Slow blinking of B indicates that the period of repetition is equal to about 1.2 seconds. Fast blinking indicates a repetition much faster (about 0.3 s).*

### 3.4 Hints and Tips

The unit accepts power from the +12 V power socket (Pext) or USB interface. You typically use Pext when performing measurement sessions or charging the internal battery of radio modems. When you want to download the data from the datalogger to your PC, you can simply use the USB interface.

When the datalogger is turned on, during the initial self-test, all front panel lights are lit briefly and a single beep is released. If the unit detects a USB connection, you hear a following double-beep. The eventual removal of the USB connection, in the presence of Pext, is indicated by a single beep

The transitions between operating states described above in Par.3.3, are automatic or controlled by the P button. With just one button you can manage all the functions needed in the measurement session. The use of the button, however, requires some explanation. The device recognizes two distinct types of activation, quick and prolonged (P and PP as described in 3.2). In practice the activation is quick if the button is pressed and released as soon as you hear the first beep. If the button is not released before the unit issues the second beep, the datalogger recognizes a PP activity. Generally, prolonged activity is required for operations particularly critical, that requires some attention, such as the beginning or the end of a recording session.

The phase that needs the most attention is undoubtedly the setup of the network. As described in the related chapter, before activating the measurement nodes you need to set DL02 in the initial assignment state (ASSIGN). If the previous session was correctly terminated, the unit enters to ASSIGN as default state as soon as it appears in this power. Otherwise, you should end the previously started session using the P button.



*If during the recording mode power supply is removed, the unit keeps track of the measurement session in progress, so that in case of temporary power failure, it can continue to acquire without the operator intervention. However, since the nonvolatile memory is accessed through a temporary buffer, in case of power failure the data on this buffer are lost. The buffer can contain a maximum of 528 bytes corresponding to a maximum number of data packets ranging from 25 (node with 8 acquisition channels) to 75 (node with a single acquisition channel).*

When you activate a node is advisable to pay attention to the signal recognition made by the datalogger (a single beep) and watch the power level of the received RF signal.

At the end of the assignment, once all nodes have been accepted, you should make a scan test and monitor the RF signal level for each node. In order to operate with a sufficient degree of reliability is necessary that at least the first LED of the RF POWER monitor will turn on.



*After disabling a node by removing the radio modem RM01, before start a new activation wait longer than 15 seconds, so to let fully discharge the capacitors internal to FE01/02.*

Each node has its own value of sampling time  $T_s$  stored in the SaTmr register (sample timer) of FE01/02. Note that even if two nodes have the same nominal value of  $T_s$  ( $T_{s1}=T_{s2}$ ), as they are not synchronized, due to manufacturing tolerances the actual values  $T_{s1}$  and  $T_{s2}$  may not be the same. This means that the data packets will arrive to datalogger with seemingly irregular intervals.

The datalogger has an internal quartz clock and associates each packet with the instant of time corresponding to its reception (with a resolution of 0.1 s).

When you use the Dataget program on your PC to download data from the datalogger, it is requested to specify the desired final sampling time  $T_{sf}$ , used to re-sync all the samples.

FE01/02 comes with a default value for  $T_s$  of 3 min. The default value for  $T_{sf}$  is 30 min; with these values the data are over sampled by a 10:1 ratio. Dataget generates an ASCII file where each line corresponds in this case to time references multiple of 30 minutes and contains the interpolated average values of all the data sent by the nodes within this time interval. In other words, the row corresponding for example at the time reference of 90 min, will contain in each column the value of the physical quantity averaged between all the values received from the datalogger in the time range 75...105 min (the average will be over 10 values for what previously assumed). The values of the sampling times of the nodes and the final sampling time  $T_{sf}$  can be modified by the user according to the type of the measurement.

You should choose for  $T_{sf}$  the highest possible value making sure that measured signals would not vary significantly during this time. Besides that it is recommended to set the sampling times of the nodes to the same value  $T_s$ , with  $T_s \ll T_{sf}$  (at least 4 times).

Communication takes place with a single packet transmitted from measurement node every  $T_s$  seconds. The radio modem receiver (datalogger side) performs an integrity check of the packet and it will only be accepted if no errors occurs (the protocol uses efficient techniques of CRC). If the packet is accepted, the receiver sends an ACK response to the node; otherwise the node will try to send back for a limited number of attempts the packet. The percentage of 99% of acknowledged packets is normally used as a benchmark to determine the useful operating range. Reliability can be immediately assessed by observing the received RF power on the LED monitor. If the received power is high you do not have any packet loss. In the case of packet loss, the over sampling used can help.

For example with a 10:1 ratio also in pessimistic assumption that a packet is lost every 10 packets transmitted, there will be an average between 9 instead of 10 values with negligible practical effects

### 3.5 Charging the battery of a node

The battery is physically located in the radio modem module (RM01 or RM01-P). To recharge the battery, simply insert the module into the datalogger DOCK0 slot. The DOCK0 red indicator provides information on the state of charge according to the following code:

**LED off:** battery charger off (no current flows into battery).

**LED on:** constant current charge (initial phase of charging).

**LED slow blinking:** constant voltage charge (final phase of charging).

**LED fast blinking:** alarm; the full charge state of the battery was not reached after about 2 ½ hours. The charger is turned off.



*Once the battery has reached the stage at constant voltage (LED indicator flashes slowly), it can be assumed that the charge stored exceeds 85% of total capacity. Before starting a new session of measurement is advisable to check that the battery of each module was charged at such level.*

If the datalogger is turned off with the radio module into DOCK0, the charger circuit is automatically disabled and will not absorb current from the battery connected.

The autonomy of a battery depends on the type of front-end connected (FE0x) and time of sampling  $T_s$ .

Refer to FE0x description for more details.



#### 4. MAINTENANCE, DOCUMENTATION AND ACCESSORIES

The unit requires no special maintenance, in case you need to clean the front panel is advisable to remove the power and use a cloth with a non-aggressive liquid (water or soap used to clean the glass).

Below are listed the documentation and coding options for DL02:

Code	Description
5001305	DL02 User's Manual
5001320	Thermozig: Reference Guide
5001340	Solarzig: Reference Guide
5001350	Photozig: Reference Guide
8802524	Interface RS485
8802865	GSM modem

##### 4.1 Replacing the battery clock

To keep the information about date and time of the internal clock, DL02 uses a small lithium battery of the following type:

###### - CR1225 (3V/48mAh)

The expected battery life is approximately 10 years. If you encounter problems on the clock data storage you can replace the battery with these simple steps:

- 1) Open the right side panel from the unit by removing the two screws.
- 2) With the help of a small screwdriver remove the battery moving it as shown in Figure 4.1.
- 3) Insert the new battery with correct polarity (the metal clip support is the positive contact).

It is recommended to replace the old battery with a battery of the same size and capacity.

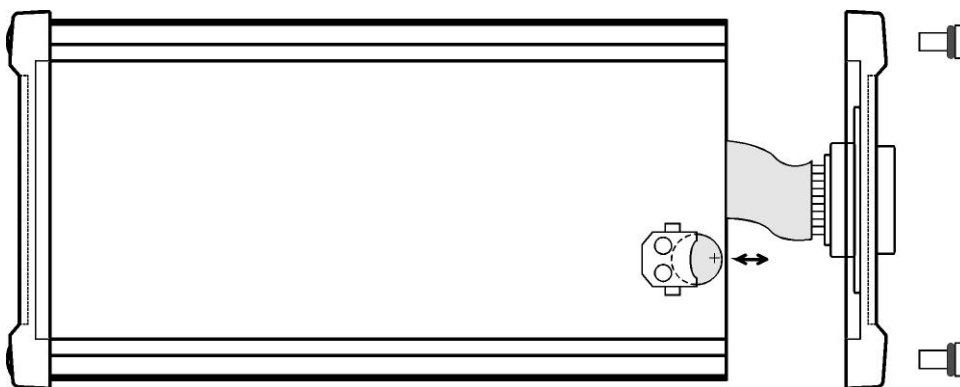

**Fig.4.1** – Replacing the clock battery

## 5. TECHNICAL SPECIFICATIONS

### MEASUREMENT NODES NUMBER

1...30

### TOTAL CHANNEL NUMBER

1...120 (depends on the configuration of the nodes)

### DATA MEMORY

2 MB (about 500,000 samples)

### DATA RESOLUTION

16/32 bit

### CHARGER SLOTS / RADIO MODEM

1

### POWER SUPPLY EXT (12V $\pm$ 30%)

12 Vdc / 25mA (typ, no radio modem)

+25 mA (with radio modem)

+35 mA (charger on)

+20 mA (GSM on)

### POWER SUPPLY USB (5V $\pm$ 10%)

5 Vdc / 40mA (typ, no radio modem)

+50 mA (with radio modem)

+75 mA (charger on)

### FEATURES

- Internal clock with battery backup
- Audible beeper for diagnostics and feedbacks
- Simplified management, a single button for all functions
- RF power monitor
- Battery charge monitor
- Optional RS485 interface
- Optional internal GSM modem

### TEMPERATURE RANGE

-10°...50°C working (RH max 85% at 25°C)

-30°...60°C storage

### DIMENSIONS

130 mm x 63 mm x 35 mm

### WEIGHT

220 g approx.



## DATAGET program

The main purpose of the program is to allow easy and quick downloading of recorded data from a datalogger belonging to DL0x family (DL01 or DL02). The program has in addition other useful features such as:

- Setting time and date of the internal clock.
- Setting SaTmr (sampling time) of measurement nodes.
- Real-time monitor of data packets received from the nodes.

The interface used for communication with the PC is the USB interface, the required operating system is Windows 2000, XP, Vista 32 or Windows 7 (32/64 bit)

## SETUP

The only thing required for the setup is to notify the operating system the first time you use the datalogger, to bind a proper driver to it.

To achieve this if you use a DL02 device is sufficient to let the OS read the proper sub-folder inside the Driver\_USB\_DL02 folder (please, see the CD supplied with the unit). If you have a DL02s device then just point at the Driver\_USB\_DL02s folder.

Procedure:

- 1) Connect the datalogger with a USB cable to your PC.
- 2) The first time the datalogger is connected, the operating system detects a new USB device on the bus and opens a installation wizard window.
- 3) Choose the option to install from a specific location and specify the path where is the driver file:

DL02: cdc\_2K\_XP\_vista.inf for 32 bit systems, cdc\_Windows7\_64.inf for 64 bit systems.

DL02s: ftdiport.inf.

- 4) Wait until you see the message of proper driver installation.

Once the driver is correctly installed, it can be useful to check the name of the associated communication port (Settings->Control Panel -> System -> Hardware -> Device Manager -> Ports (COM & LPT) -> USB to UART (COMx) or USB Serial Port (COMx) if you are using a DL02s). The number x of COMx depends on the configuration of your PC.



You can find the last release of the USB driver on the web site:  
[www.optivelox.com](http://www.optivelox.com) in the page dedicated to DL02.

Dataget is a stand alone program and does not require any setup procedures, just copy the file Dataget.exe in the working directory of your hard disk. It is recommended to create a shortcut on your desktop in order to facilitate the execution of the program.

## USING THE PROGRAM

Before running the program make sure the USB cable is properly installed.

The first operation of Dataget after its invocation is to check the presence of the datalogger. In the event that it is properly recognized, the program automatically displays the main menu window:

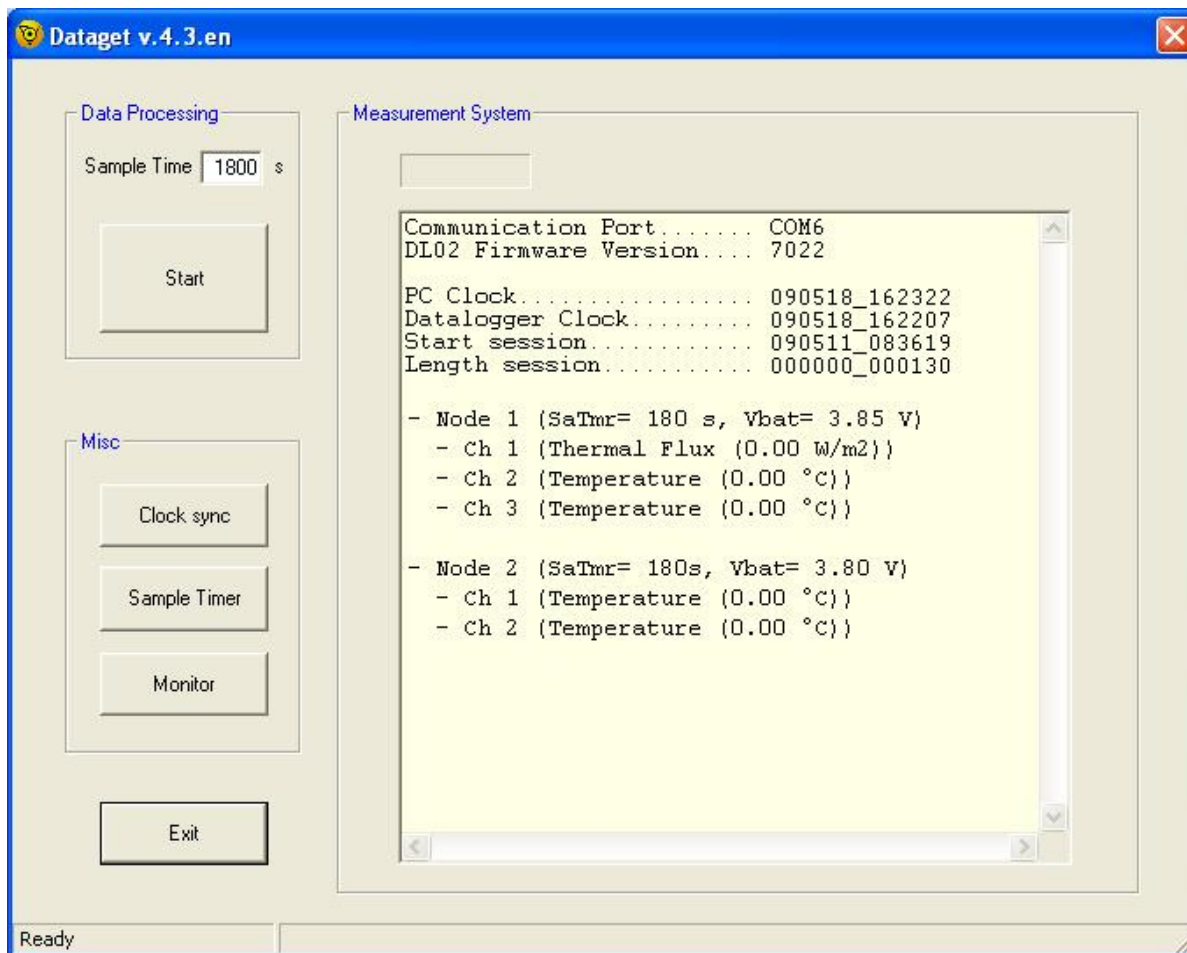

*If the program does not recognize the datalogger, a window appears with a list of all COM ports defined in the system. It is possible with a double click of the mouse to try to manually select the COM port of the datalogger. In case of errors you should:*

- quit Dataget
- turn off the datalogger removing the USB connection
- plug again the datalogger via USB cable and wait for the double beep
- run Dataget

The main menu reports three control groups:

- Measurement System
- Data Processing
- Misc

**Measurement system**

This group shows the general information about the session. The first line shows the communication port through which the program is currently connected to the datalogger (in this example the COM6 port). The second line reports the firmware version of the unit.

The next two lines show the measured time by the two clocks, the clock of the PC that is running Dataget program and the internal clock of the datalogger. If you want to synchronize the two clocks, simply press the button "Clock sync" as explained later.

Following the clock lines there is the time reference of the start of the last session recorded. The notation used for the string is:

YYMMDD\_hhmmss

YY	MM	DD	hh	mm	ss
year	month	day	hour	minute	second

For example, in this case Dataget was started on 18/05/2009 at 16.23 and 22 seconds. The last recorded session started on 11/05/09 at 8.36 and 19 seconds.

The following line shows the total duration of the measurement session. The notation is this case DDDDDD\_hhmmss (in the example above, the duration is 1 minute and 30 seconds).

The latest information on the screen refers to the measurement nodes. For each node there is a line showing the address associated with it, the value of SaTmr the voltage of the battery. For each channel run by the node is shown immediately after its number along with the type of physical quantity and units of measurement.



*The battery voltage refers to the start of the session, it is advisable to start the measurement with Vbat > 3.7 V. If the node does not use batteries (for example FE03/04), the voltage Vbat is the value of the main power supply.*

**Data Processing**

Before creating the output file you must synchronize all the data to the desired final sampling time (Tsf, described in Par.3.4).

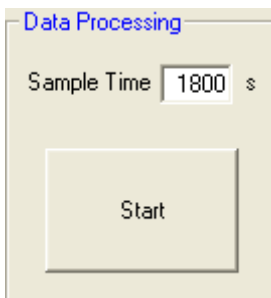

The value of Tsf must be specified in the Sample Time field. Values not allowed are marked with a red background.

After pressing the "Start" button the program activates the data processing at the end of which the Formatting output file window is open.

Item	Time	CH1_1: Thermal Flux (0.00 W/m2)	CH1_2: Temperature (0.00 °C)	CH1_3: Temperature (0.00 °C)	CH2_1: Temperature (0.00 °C)	CH2_2: Temperature (0.00 °C)
1	080329_191318	18.87	13.99	14.44	5.91	6.52
2	080329_194318	17.24	13.78	14.25	5.60	6.31
3	080329_201318	15.47	13.61	14.08	5.25	6.15
4	080329_204318	14.82	13.49	13.96	5.12	5.96
5	080329_211318	14.02	13.41	13.85	4.90	5.80
6	080329_214318	13.55	13.34	13.76	4.62	5.55
7	080329_221318	12.96	13.27	13.68	4.41	5.41
8	080329_224318	12.47	13.22	13.61	4.24	5.28
9	080329_231318	12.12	13.17	13.54	4.11	5.20
10	080329_234318	11.73	13.12	13.48	3.86	4.99
11	080330_001318	11.34	13.07	13.42	3.78	4.90
12	080330_004318	11.14	13.02	13.37	3.56	4.71
13	080330_011318	11.21	12.99	13.33	3.43	4.61
14	080330_014318	15.79	13.14	13.49	3.27	4.52
15	080330_021318	15.68	13.25	13.57	3.18	4.44
16	080330_024318	14.94	13.25	13.57	3.01	4.33
17	080330_031318	14.51	13.23	13.55	2.88	4.22
18	080330_034318	13.82	13.19	13.51	2.77	4.12
19	080330_041318	13.05	13.14	13.47	2.69	4.06
20	080330_044318	12.28	13.07	13.40	2.56	3.92
21	080330_051318	11.67	13.01	13.34	2.37	3.81
22	080330_054318	11.47	12.95	13.28	2.42	3.84
23	080330_061318	15.56	13.06	13.41	2.46	3.85
24	080330_064318	16.56	13.20	13.51	2.95	3.92
25	080330_071318	15.43	13.19	13.51	2.79	4.07
26	080330_074318	14.56	13.17	13.48	3.07	4.28
27	080330_081318	14.42	13.13	13.44	3.55	4.68
28	080330_084318	13.69	13.07	13.40	4.00	5.02
29	080330_091318	13.04	13.01	13.35	4.42	5.36
30	080330_094318	12.41	12.94	13.28	4.94	5.75
31	080330_101318	15.26	12.99	13.34	5.51	6.25
32	080330_104318	18.07	13.17	13.50	6.46	6.98
33	080330_111318	17.17	13.20	13.52	7.61	8.02
34	080330_114318	16.39	13.19	13.51	8.58	8.83
35	080330_121318	16.03	13.15	13.48	9.16	9.23
36	080330_124318	15.12	13.09	13.44	9.95	9.90
37	080330_131318	14.37	13.02	13.39	11.19	11.28
38	080330_134318	13.58	12.95	13.31	12.75	12.68
39	080330_141318	13.13	12.89	13.24	12.86	12.53
40	080330_144318	15.66	12.92	13.29	13.20	12.80
41	080330_151318	17.01	13.05	13.39	16.56	12.82
42	080330_154318	16.62	13.06	13.39	14.47	12.20
43	080330_161318	15.89	13.04	13.37	12.48	11.30
44	080330_164318	15.43	13.00	13.33	11.48	10.76
45	080330_171318	14.49	12.96	13.29	10.69	10.20
46	080330_174318	13.84	12.90	13.24	10.16	9.84
47	080330_181318	13.08	12.85	13.17	9.45	9.31
48	080330_184318	12.58	12.80	13.11	8.78	8.83
49	080330_191318	15.20	12.85	13.18	8.41	8.56
50	080330_194318	18.34	13.08	13.39	7.97	8.26

Each line identifies the data sampled at Tsf. The data of measurement channels (5 in this example) are reported on a white background.

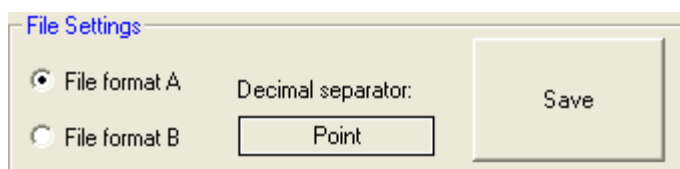

Pressing the "Save" button, the data can be saved in an output file. The default file name is automatically determined by the session start date. However, you can specify a different file name.

The output file can be formatted according to selector (A / B) and the decimal separator (point / comma).

Example of output file using **A** format and decimal point:

```
Start: 060201_120000
Time[s]: 600
"CH1_1: Temperature(0.00 °C)" "CH1_2: Temperature(0.00 °C)" "CH1_3: Thermal Flux(0.00 W/m2)"
19.80 19.78 8.08
19.60 19.64 6.54
...
```

Example of output file using **B** format and decimal point:

```
"DATE: "; "TIME: "; "CH1_1: Temperature(0.00 °C)"; "CH1_2: Temperature(0.00 °C)"; "CH1_3: Thermal Flux(0.00 W/m2)"
"01.02.06"; "12:00:00"; 19.80; 19.78; 8.08
"01.02.06"; "12:10:00"; 19.60; 19.64; 6.54
...
```

After the file is saved, the program automatically searches for the presence of plugins for post-processing the data. The plugins are searched in the same directory of Dataget.exe. If at least one plugin is present, the program opens a window of the following type:

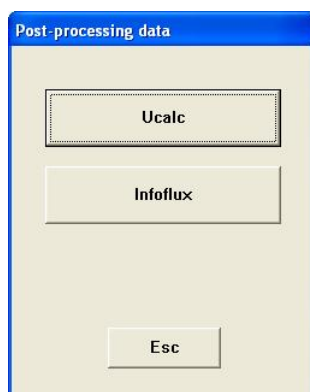

For example the Ucalc plugin is required if you want to calculate the thermal transmittance.

If you choose to run a plugin, the program opens it sending through the command line the data file name so that the user can immediately interact with the last working session. You can connect the PC to the datalogger during a measurement session and launch a post-processing plugin, working immediately on the data so far acquired. Based on the result of processing you can decide to terminate the measure and avoid further wasting time.

Before you generate the output file you can modify if necessary the data using some useful editing functions available to the program:

- **Sorting Columns.** You can change the order of the columns at will. You start by deciding what column should be the first on the left. You select the column by clicking the left mouse button on any of its data (the column is then highlighted in yellow) and moves it to the left using the "<<< Move column" button. Note that you can de-select a column just clicking the right mouse button on it.
- **Merging Columns.** Two or more columns can be merged together with the result of creating a single data column containing the arithmetical mean values of the original columns. To do this you must select the columns you want to merge and press the "Merge column" button. On completion of the merger, the resulting column is highlighted in yellow.
- **Deleting Columns.** One or more data columns can be deleted. To do this you must select the columns you want to delete and press the "Delete column" button.
- **Deleting Items.** You can delete one or more items at the beginning or at the end of the measurement session. To do this you must first select the items and then press the "Delete item" button. Select an item with a click of the left mouse button on Item or Time field of the item (the item background becomes blue). For multiple selections hold down the Shift key while using the mouse.



*If you want to delete a lot of items keeping just a few of them, you can select the items you want to keep and then with a click of the right button mouse on the item or Time field, you can invert the selection.*

- **Graph.** The data of one or more data columns can be displayed graphically facilitating the analysis of the physical quantities in time. To do this you must select the columns you want to display and press the "Graph" button.
- **Editing a column header.** You can edit the text of the column clicking the left mouse button on the column header.
- **Editing a data.** You can edit the value of a data with a double click of the left button on it. Note: the Item or Time values are not editable.



Examples of selection for columns and items:

**Formatting output file**

File Settings:  
 File format A    Decimal separator:    Save  
 File format B    Point

Item	Time	CH1_1: Thermal Flux (0.00 W/m2)	CH1_2: Temperature (0.00 °C)	CH1_3: Temperature (0.00 °C)
1	080329_191318	18.87	13.99	14.44
2	080329_194318	17.24	13.78	14.25
3	080329_201318	15.47	13.61	14.08
4	080329_204318	14.82	13.49	13.96
5	080329_211318	14.02	13.41	13.85
6	080329_214318	13.55	13.34	13.76
7	080329_221318	12.96	13.27	13.68
8	080329_224318	12.47	13.22	13.61
9	080329_231318	12.12	13.17	13.54
10	080329_234318	11.73	13.12	13.48
11	080330_001318	11.34	13.07	13.42
12	080330_004318	11.14	13.02	13.37
13	080330_011318	11.21	12.99	13.33
14	080330_014318	15.79	13.14	13.49
15	080330_021318	15.68	13.25	13.57
16	080330_024318	14.94	13.25	13.57

**Formatting output file**

File Settings:  
 File format A    Decimal separator:    Save  
 File format B    Point

Item	Time	CH1_1: Thermal Flux (0.00 W/m2)	CH1_2: Temperature (0.00 °C)	CH1_3: Temperature (0.00 °C)
1	080329_191318	18.87	13.99	14.44
2	080329_194318	17.24	13.78	14.25
3	080329_201318	15.47	13.61	14.08
4	080329_204318	14.82	13.49	13.96
5	080329_211318	14.02	13.41	13.85
6	080329_214318	13.55	13.34	13.76
7	080329_221318	12.96	13.27	13.68
8	080329_224318	12.47	13.22	13.61
9	080329_231318	12.12	13.17	13.54
10	080329_234318	11.73	13.12	13.48
11	080330_001318	11.34	13.07	13.42
12	080330_004318	11.14	13.02	13.37
13	080330_011318	11.21	12.99	13.33
14	080330_014318	15.79	13.14	13.49
15	080330_021318	15.68	13.25	13.57
16	080330_024318	14.94	13.25	13.57

Example of graph:

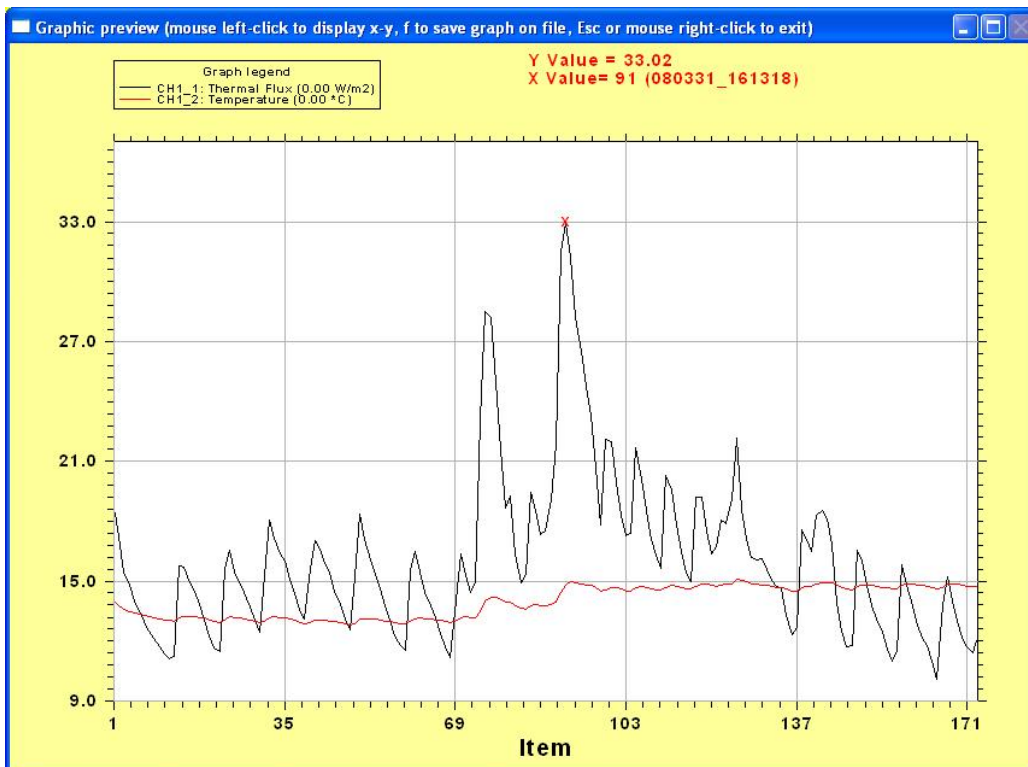



Click the left mouse button on the graph to display the values of  $x$  and  $y$  coordinates (shown in red in the top right corner of the screen).

Pressing the "f" key you can save the graphics in a file as WMF format.

## Misc

This group of commands provides access to auxiliary functions of the program:

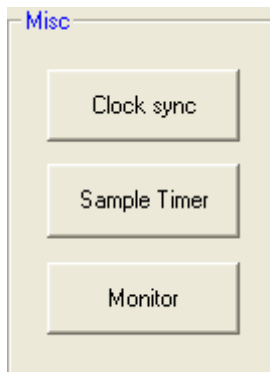

- **Clock sync:** set the clock of the datalogger (date and time) synchronizing it with the current PC value.

- **Sample Timer:** set the sampling time  $T_s$  of a FE0x device. To set a new value for the sampling time of a node you must follow step by step the following procedure:

- 1) Turn on the datalogger with external power supply and make sure to be in the initial assignment state (B turned on green).
- 2) Connect the datalogger to a PC via USB and open the program Dataget.
- 3) Press the "Sample Timer" button and set the requested value for the sampling time (1...65535 seconds).
- 4) Activate all the FE0x devices you want to modify (i.e., connect a radio modem to each FE0x).
- 5) Press the button P of the datalogger to invoke the test procedure. During this procedure, the nodes are polled in sequence and each SaTmr register (internal to FE0x) is loaded with the new value. At the end of the test procedure the new values are effective and the datalogger returns to the assignment state. In case at least one FE0x fails the command, the datalogger enters into FAULT state and the entire procedure must be repeated.

- **Monitor:** display the incoming packets from measurement nodes.

The monitor window is useful for verifying in real-time the proper functioning of the wireless data acquisition system.

```

Monitor
Receiving data in real time
BC>> NodeAd= 3 ChaNu= 3 SaTmr= 2 Cf[0]= 0x1742 Cf[1]= 0x8101 Cf[2]= 0x8301 Ubat=
BC>> NodeAd= 4 ChaNu= 2 SaTmr= 60 Cf[0]= 0x8301 Cf[1]= 0x8101 Ubat= 389
TEST>> NodeAd= 3 OK
TEST>> NodeAd= 4 OK
17:31:20>> NodeAd= 3 Ux[0]= -1674 Ux[1]= 2384 Ux[2]= 2368 Tboard= 211 Ubat= 381
17:31:21>> NodeAd= 4 Ux[0]= 2357 Ux[1]= 2342 Tboard= 219 Ubat= 388
17:31:23>> NodeAd= 3 Ux[0]= -1568 Ux[1]= 2385 Ux[2]= 2369 Tboard= 212 Ubat= 387
17:31:25>> NodeAd= 3 Ux[0]= -1524 Ux[1]= 2386 Ux[2]= 2369 Tboard= 212 Ubat= 387
17:31:27>> NodeAd= 3 Ux[0]= -1478 Ux[1]= 2387 Ux[2]= 2370 Tboard= 212 Ubat= 387

```

In this example, the monitor function is activated prior to the assignment of two measurement nodes. Each row displays the information packet received from a node. The prefix BC>> indicates that the node has sent a packet with broadcast address that is the node is in POLLING state and it is waiting to be acknowledged by the datalogger. After the BC>> prefix the following information are displayed:

**NodeAd** = node address (each FE0x has a unique address).  
**ChaNu** = number of channels of the node (varies according to the FE0x type).  
**SaTmr** = sampling time  $T_s$  of the node (SaTmr register).  
**Cf[n]** = configuration parameter of the channel n.  
**Vbat** = voltage of the battery supply (battery of radio modem RM01/RM01-P).

If you run the test routine with the monitor window active, for each queried node you will see a line containing the address of the node and its status (OK, or ? if the node did not respond). In this example, both nodes, with address 3 and 4, have responded correctly.

This function is useful when you have many nodes in the network and you want to identify if a problem occurs which is the node responsible.

Going after to registration phase, the datalogger commands the nodes to enter in RUN mode (for details see the section about FE01/02). A node in RUN mode sends every SaTmr second a data packet. You can see on the monitor window these packets preceded by a reference time (hh:mm:ss>>) which is the time the datalogger has received it. Each packet also shows the following information:

**NodeAd** = node address (each FE0x has a unique address).  
**Vx[n]** = value of the physical quantity of channel n.  
**Tboard** = internal temperature of the node.  
**Vbat** = voltage of the battery supply (battery of radio modem RM01/RM01-P).



*It may be useful to activate the monitor in an intermediate stage of the session to control the correct flow of data and in particular to ensure that the battery voltage of each node is sufficiently higher than the minimum allowable value (3.3 V).*

At any time you can save the contents of the monitor window as an ASCII file using the Save button. The file, named DL01mon.txt, is saved in the same directory of Dataget.exe.

During a recording session the "Display Channels" button becomes active and you can open the menu dedicated to the channel selection:

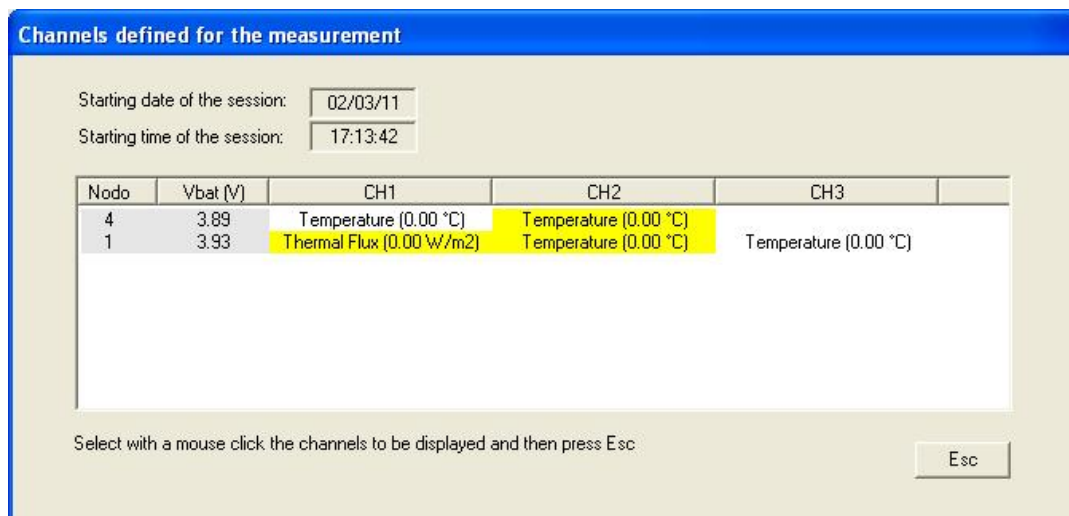

For each node of the network is shown the address, the battery voltage the list of data channels. With a click of left mouse button you can select / deselect up to a maximum of 8 channels simultaneously. The values of the selected channels are displayed in real-time right after have pressed the Esc button.



To change the displayed channels enter again into selection menu by pressing "Display Channels". To exit from the monitor function press the Esc button of the Monitor menu.

To end the Dataget program press Exit from the main menu.

## SOFTWARE UPDATES

The latest version of the Dataget software at the time of printing of this manual is the V.4.3. For detailed information on the history of revisions, see the file Dataget\_rev.txt in the installation CD.

## RM01 Radio Modem

The RM01 is a radio modem module operating in the 2.4 GHz ISM band (Industrial, Scientific & Medical). Thanks to compatibility with the IEEE 802.15.4 and ZigBee protocols, it allows the implementation of low power sensor networks.

The typical outdoor range is 100 meters or over 1 km using the RM01-P model with higher transmission power. Inside the module is a built-in battery that can be used to power supply both the modem and a device of the FE01/02 families. The internal battery is rechargeable and can be fully restored within a couple of hours using a charger compatible with Li-Po batteries or inserting the module into the slot of a datalogger DL01 or DL02.

The complete network comprises one or more nodes equipped with measurement sensors and one coordinator node (datalogger). Each node has a radio modem RM01 operating according to the ZigBee standard; the communication takes place via a star network (denominated DataZig) in which the datalogger is its center. Each node operates with its own unique address and is able to automatically repeat the communication in case of collision or improper reception of the data.

The battery life is optimized by the communication protocol; each measurement node remains active only for the time necessary to transfer data and then is automatically turned off. The frequency of sampling is determined by the front end device (FE01/02).

In order to use a radio modem RM01 with a front end FE01/02 and build a measurement node is sufficient to connect together the two modules through their DB9 connectors. Once made the connection, both devices are powered by the internal modem battery and the node becomes ready to operate.



*The radio modem is equipped with a RPSMA female connector for an external antenna. Use only the supplied antenna or an antenna approved by the manufacturer.*



Fig.C.1 – Radio Modem RM01

**INTERNAL BATTERY**

The battery contained in RM01 or RM01-P module is a Li-Po (Lithium Polymer) battery; it has a typical voltage of 3.7 V, very low self-discharge current and shows no "memory" effect.



The battery is capable of delivering a very high current. You should prevent a short circuit on the connector pin or the contact with conductive liquids.

The recommended charging procedure involves an initial phase of charge at constant current until a battery voltage of 4.2 V is reached and then a second charge phase with constant voltage. The current recommended for the first phase is 75 mA. The charge is assumed complete when during the second phase the battery current falls below the value of 7.5 mA.



*At the end of the first charging phase, it can be assumed that the battery has reached about 85% of its total capacity.*



The battery is damaged for charging voltages beyond 4.2 V, or if during discharge the voltage drops below 2.7 V. Use only chargers specially designed for Li-Po battery.

**ORDERING CODES**

Following are shown the RM01 devices available at the time of printing this manual and their codes:

Code	Name	Description
8802201	RM01	Radio Modem RF power max = 1 mW
8802211	RM01-P	Radio Modem RF power max = 100 mW

**TECHNICAL SPECIFICATIONS****RF POWER MAX**

1 mW (0 dBm) RM01

100 mW (20 dBm) RM01-P

(Note: when operating in some countries RM01-P must be configured to operate at a maximum transmit power output level of 10 dBm. Please specify when ordering if you want the power is limited to this value)

**OPERATING FREQUENCY**

2.4 GHz (ISM band)

**COMMUNICATION RANGE**

25 m (indoor) RM01

45 m (indoor) RM01-P

250 m (outdoor RF line-of-sight range) RM01

1300 m (outdoor RF line-of-sight range) RM01-P

**DATA RATE SERIAL INTERFACE**

19200 bps

**POWER SUPPLY**

3.3...5.1 Vdc

45 mA (TX), 50 mA (RX) RM01

220 mA (TX), 55 mA (RX) RM01-P

**BATTERY**

Li-Po 3.7 V / 145 mAh, rechargeable

Low self-discharge

No memory effect

&gt; 500 charge cycles

**TEMPERATURE RANGE**

-20°...50°C working (RH max 85% at 25°C)

-30°...60°C storage

**DIMENSIONS**

40 mm x 40 mm x 20 mm (excluding connector)

**WEIGHT**

40 g approx.

## CB01 Battery Charger

CB01 is a device designed to recharge the batteries contained in the radio modem RM01. This function is provided also by the datalogger DL02, however, if the measurement system uses a large number of nodes, can be useful to use one or more CB01 devices to recharge the batteries all at once. The charger CB01 is equipped with three independent slots and can recharge 3 batteries at the same time.

To recharge the battery of a RM01 device, simply insert the module into any of the three slots provided. The lithium polymer battery contained in the radio modem requires a great accuracy in voltage and current during the charging so that its high performance may remain unchanged over time. For the reasons outlined above, in this device all charging phases are handled automatically by a microprocessor in order to ensure a speedy and secure operation.

Each slots is equipped with a red LED indicator that provides information on the state of charge using the following encoding:

**LED off:** battery charger off (no current flows into battery).

**LED on:** constant current charge (initial phase of charging).

**LED slow blinking:** constant voltage charge (final phase of charging).

**LED fast blinking:** alarm; the full charge state of the battery was not reached after 2 ½ hours. The charger is turned off.



*Once the battery has reached the stage at constant voltage (LED indicator flashes slowly), it can be assumed that the charge stored exceeds 85% of total capacity. Before starting a new session of measurement is advisable to check that the battery of each module was charged at such level.*

If the CB01 is turned off with the radio module into its slots, the charger circuit is automatically disabled and will not absorb current from the batteries connected.



**Fig.D.1** – Charger of Batteries CB01



**GENERAL WARNINGS**

- Make sure that mains power supply complies with the characteristics reported in technical specifications.
- Plug the radio modems into the connectors P1, P2 and P3. The progress of each battery charge is indicated by the corresponding LED.
- Use the device only in dry environments.
- Do not open the unit for any reason, in case of malfunction please contact the service. The opening of the unit will void the warranty.
- If the charger is not used, remove the mains power supply.



**Fig.D.2** – Simultaneous charging of two batteries

**ORDERING CODES**

Following are shown the codes of CB01 and its accessory:

Code	Name	Description
8802800	CB01	Charger of Batteries CB01
8800006	-	Mains power supply 12V/0.3A

**TECHNICAL SPECIFICATIONS****NUMBER OF CHARGING DOCKS**

3 (simultaneously operating)

**POWER SUPPLY (12V  $\pm$ 30%)**

12 Vdc / 10mA (empty docks)

+ 130 mA max (all docks operating)

**FEATURES**

- Automatic charging slopes managing
- Charging battery status indicator
- Safety charge timeout

**TEMPERATURE RANGE**

-10°...50°C working (RH max 85% at 25°C)

-30°...60°C storage

**DIMENSIONS**

130 mm x 65 mm x 35 mm

**WEIGHT**

100 g approx.

## FE02 Front End

Each FE02 is a complete multi-channel acquisition system specifically designed for accurate measurements of surface temperatures and / or thermal fluxes. The device includes sensors for measurement, signal conditioning circuitry and circuitry to interface the radio modem.

A radio modem of RM01 family can be directly connected to the DB9 connector of FE02 and once connected, both devices are powered by the internal battery. Just add a radio modem to a FE02 device and you get a complete measurement node able to communicate with DL01 or DL02 dataloggers.

All the configuration parameters, such as the sampling time  $T_s$ , are stored into the internal non-volatile memory. Every  $T_s$  seconds, FE02 converts the sensor signals into digital signals and sends them into a data packet to the datalogger.

Thanks to a low-power electronic circuitry, each measurement node is able to operate with very high autonomy; the battery life can vary from one day ( $T_s = 1$  s) up to several months ( $T_s > 1$  min). The battery, internal to the radio modem, is rechargeable and can be fully restored within a couple of hours.

Each FE02 is capable of handling from 1 to 6 independent measuring channels. There are various models of FE02 with different number and type of the sensors used.

The FE02 devices are pre-calibrated and interchangeable with each other. Since the datalogger is able to automatically detect the number of channels and the related physical quantities, it is not requested by the operator any further configuration.

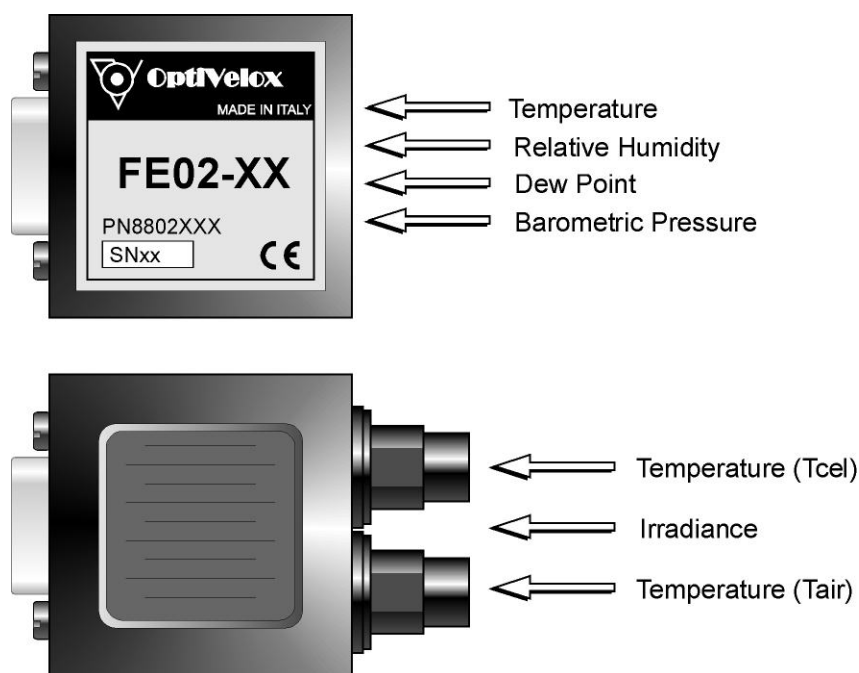

Fig.E.1 – Front End FE02

## ACTIVATION OF A MEASUREMENT NODE

The activation of a node is done by connecting together a FE02 and a radio modem of RM01 family (RM01 or RM01-P). After the connection, the node is powered from the battery inside the modem and the FE02 is forced into the initial state (POLLING state).



*For the sake of simplifying the discussion it is convenient to refer to the node rather than FE02 itself. So we will say that a node is in polling state when the FE02 is in this state.*

In the state of POLLING, the node transmits to datalogger every 5 seconds a data packet containing some significant parameters, indicating at the same time its presence on the network. During the POLLING state all the circuits of the node are powered and there is the maximum current absorption. The node, as well as transmit data, is also capable of receiving instructions from the datalogger (e.g., the datalogger may prevent the node to transmit packets, or may force the node into RUN mode).

The following figure shows the typical discharge curve of the internal battery for the node in POLLING state. The battery life with the modem RM01-P is less than RM01 due to the higher power consumption of the -P version.

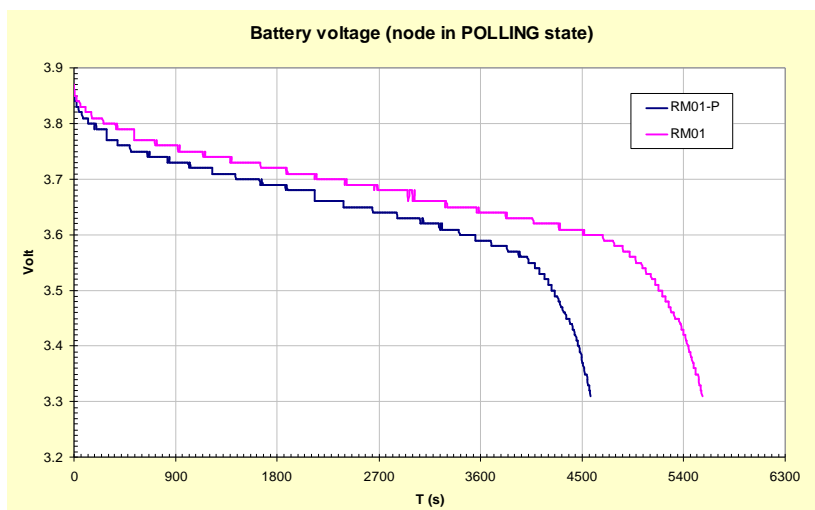

It is recommended to enter the node in RUN mode before the voltage drops below 3.7 V or at least before the voltage approaches the final knee (values around 3.6 V). Once the node goes in RUN mode it operates in low power and, as you can see using the monitoring function of Dataget program, the value of the battery voltage returns to higher levels.

The node is forced into RUN state during the measurement session. In this state it periodically performs the measurement from its sensors and sends to the datalogger a packet containing the data in digital format. The sample time  $T_s$  is placed into the internal non-volatile SaTmr register (Sample Timer) and can vary from 1 to 65535 seconds. As the current demanded from the battery is significant only for a very short time every  $T_s$  seconds, the autonomy of the node becomes very high, especially for high sampling times.

During the RUN state, the node passes much of its time in sleep mode and therefore it is not able to receive instructions from the datalogger. The only way to exit from RUN is to turn off the node by disconnecting the two modules RM01 and FE02.



*Before you reactivate a node wait longer than 15 s to allow complete discharge of all the capacitors inside the FE01, otherwise the node may remain in RUN state.*

FE02 devices since version 2.3 may be awakened by a command sent from the datalogger (for details, see the description of DL01/02).

## BATTERY LIFE

The following table shows the theoretical life range (expressed in hours) expected from the activation of a node with a fully charged battery in the various operating conditions and with two different types of modem (the modem RM01-P has a higher RF power and, consequently, a higher current consumption). Ts represents the sampling time of the node expressed in seconds.

<b>Battery life of a measurement node</b> (value expressed in hours, Ts expressed in seconds)		
	<b>POLLING state</b>	<b>RUN state</b>
<b>Node with RM01</b>	1.5	$145000 * Ts / (2000 + 11 * Ts)$
<b>Node with RM01-P</b>	1.3	$145000 * Ts / (8000 + 11 * Ts)$

For example, a node in RUN state with  $Ts = 1$  s can operate for about 72 h or for about 3270 h with  $Ts = 1$  min (the theoretical range is respectively 18 h and 1000 h with the module RM01-P).

The FE01 devices come with the default value of SaTmr = 180 (i.e.,  $Ts = 3$  min), taking into account a slight degradation due to the phenomenon of self-discharge of the battery, it can be estimated in this case a battery life of around 5 months with RM01 and 2 months with RM01-P.



*In order to preserve the battery of the radio modem, FE01 automatically enters permanently in sleep mode if the power supply voltage drops below the value of 3.3 V.*

## ORDERING CODES

Following are shown the FE02 devices available at the time of printing this manual and their codes:

Code	Name	Description
8802710	FE02-1A	Front End with 1 channel: - 1 barometric pressure probe
8802715	FE02-1B	Front End with 1 channel: - 1 irradiance probe
8802712	FE02-2A	Front End with 2 channels: - 1 surface temperature probe - 1 surface temperature probe
8802700	FE02-3A	Front End with 3 channels: - 1 air temperature probe - 1 RH probe - 1 dew point probe
8802705	FE02-3B (1)	Front End with 3 channels: - 1 irradiance probe - 1 surface temperature probe - 1 air temperature probe
8802707	FE02-3C	Front End with 3 channels: - 1 thermal flux probe - 1 surface temperature probe (internal to flux probe) - 1 surface temperature probe
8802720	FE02-4A	Front End with 4 channels: - 1 air temperature probe - 1 RH probe - 1 dew point probe - 1 barometric pressure probe
8802725	FE02-6A	Front End with 6 channels: - 1 thermal flux probe - 1 surface temperature probe (internal to flux probe) - 1 surface temperature probe - 1 air temperature probe - 1 RH probe - 1 dew point probe



*Each channel of a Front End is associated to a single physical quantity. For channels with more sensors, the measured quantity is equal to the average of the measurement of the individual sensors.*

*The order code must be completed by the address of the device (1÷30), for example:*

*FE02-4A-02 (FE02 device with 4 channels and network address = 2)*

(1)  
Front End used for meteo stations SM01 and SM02.

**TECHNICAL SPECIFICATIONS**

## NUMBER OF CHANNELS

1...6

## DATA RESOLUTION

16 bit

## SAMPLING TIME

1...65535 s

## POWER SUPPLY

3.3...5.1 Vdc

0.003...5 mA (depending on the sampling time)

## TEMPERATURE RANGE

-20°...60°C working (RH max 85% at 25°C)

-30°...60°C storage

## DIMENSIONS

40 mm x 40 mm x 20 mm (excluding connector and external probes)

## WEIGHT

45 g approx. (excluding external probes)

**E.1 TEMPERATURE (-3A, -4A, -6A)**

## RESPONSE TIME

5...30 s

## OPERATING RANGE

-20...60°C

## RESOLUTION

0.01 °C

## ACCURACY

± 0.3°C (@25°C)

## REPEATIBILITY

±0.1°C

**E.2 RELATIVE HUMIDITY (-3A, -4A, -6A)**

## RESPONSE TIME

8 s (typ)

## OPERATING RANGE

0...100%

## RESOLUTION

0.03%

## ACCURACY

±2% (@10...90%)

## REPEATIBILITY

±0.1%

**E.3 DEW POINT (-3A, -4A, -6A)**

## ACCURACY

 $\pm 0.5^{\circ}\text{C}$  (@RH=60...90%, T=25°C)**E.4 BAROMETRIC PRESSURE (-1A, -4A)**

## OPERATING RANGE

600...1200 hPa

## RESOLUTION

0.015 hPa

## ACCURACY

 $\pm 0.5$  hPa (@10...40°C) relative $\pm 1.5$  hPa (@10...40°C) absolute

## TEMPERATURE RANGE

-20...60°C

**E.5 SURFACE TEMPERATURE (-2A, -3B, -3C, -6A)**

## TYPE OF SENSOR

RTD Pt1000, Class 1/3 B (DIN/IEC751)

## RESPONSE TIME

8 s

## OPERATING RANGE

-50...125°C

## RESOLUTION

0.01 °C

## ACCURACY

 $\pm (0.10+0.017|t|)$  °C

## MATCHING

 $\pm 0.05$  °C (between two channels @T=20°C)

## PROBE CABLE

High temperature twisted cable. L = 1.4 m

## DIMENSIONS

Ø20 x 3 mm

## WEIGHT

1.5 g approx.

More details on the accuracy of the temperature sensors Pt1000 are shown in the figure below.



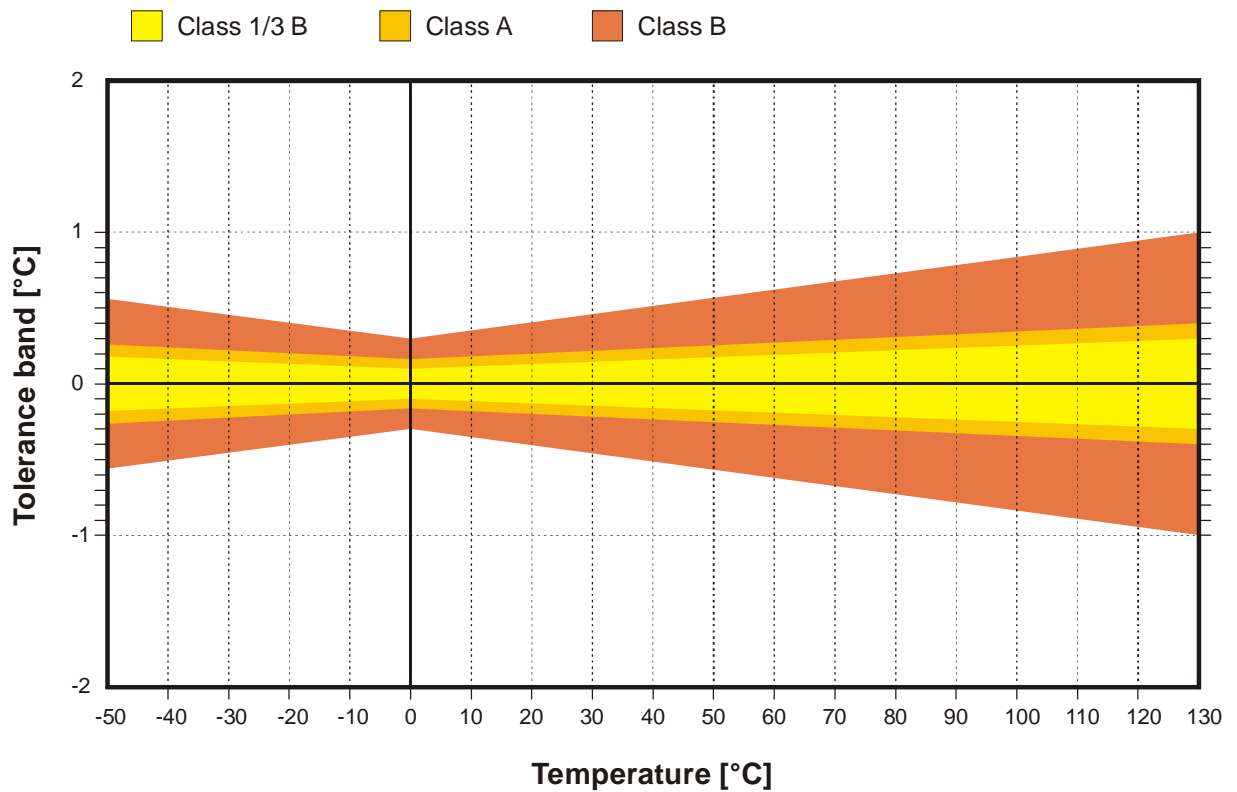

### E.6 IRRADIANCE (-3B, -1B)

#### TYPE OF SENSOR

Polycrystalline silicon, temperature compensated cell

#### RESPONSE TIME

<1 s

#### OPERATING RANGE

0÷1500 W/m<sup>2</sup>

-20÷50 °C

#### RESOLUTION

0.1 W/m<sup>2</sup>

#### ACCURACY

± (2.5% rdg + 20 dgt)

### E.7 THERMAL FLUX (-3B, -6A)

#### RESPONSE TIME

4 min

#### OPERATING RANGE

-300÷300 W/m<sup>2</sup> (positive values with flux entering the label side)

#### RESOLUTION

0.01 W/m<sup>2</sup>

#### ACCURACY

± 5% (@T=20°C)

## TEMPERATURE RANGE

-20÷60°C with temperature dependence of 0.1%/°C (typ)

## THERMAL RESISTANCE

< 0.006 m<sup>2</sup>K/W

## DIMENSIONS

Ø80 x 5.5 mm

## WEIGHT

70 g approx.