**User's
Manual**

ADMAG *AE*

**Models AE100, AE200 and AE300
Integral Type Magnetic Flowmeter**

[Style S1:AE*SC]**

[Style S2:AE*M*]**

IM 1E7B0-02E

Contents

1.	INTRODUCTION	1-1
2.	HANDLING PRECAUTIONS	2-1
	2.1 Checking Model and Specifications	2-1
	2.2 Accessories	2-1
	2.3 Storage Precautions	2-1
	2.4 Installation Location Precautions	2-1
	2.5 Converter Reorientation Precautions	2-1
3.	COMPONENT NAMES	3-1
4.	INSTALLATION	4-1
	4.1 Piping Design Precautions	4-1
	4.2 Handling Precautions	4-3
	4.2.1 General Precautions	4-3
	4.2.2 Flow Tube Piping	4-4
	4.2.3 Alteration of LCD Display Orientation	4-4
	4.3 Mounting	4-5
	4.3.1 Nominal Diameter 2.5 mm (0.1in.) to 10 mm (0.4in.) Union Joint Type	4-5
	4.3.2 Nominal Diameter 2.5mm (0.1in.) to 40mm (1.5in.) Wafer Type	4-6
	4.3.3 Nominal Diameter 50 mm(2in.) to 300 mm(12in.) Wafer Type	4-9
	4.3.4 Nominal Diameter 15 mm (0.5in.) to 400 mm (16in.) Flange Type	4-12
	4.3.5 Mounting Procedure for Sanitary Type	4-14
	4.4 Wiring Precautions	4-14
	4.4.1 Protective Grounding	4-14
	4.4.2 General Precautions	4-15
	4.4.3 Power and Output Cables	4-15
	4.4.4 DC Connections	4-15
	4.4.5 Wiring Ports	4-15
	4.4.6 Connecting to External instruments	4-16
5.	BASIC OPERATING PROCEDURES	5-1
	5.1 Liquid Crystal Display	5-1
	5.2 Types of Display Data	5-2
	5.2.1 Flow Rate Data Display Mode	5-3
	5.2.2 Setting Mode	5-6
	5.2.3 Alarm Display Mode	5-9
6.	FUNCTION AND DATA SETTINGS	6-1
	6.1 Setting Flow Span	6-1
	6.2 Power Frequency	6-4
	6.3 Other Functions and Settings	6-4
	6.3.1 Pulse Output	6-4
	6.3.2 Display of Internal Totalization Values	6-6
	6.3.3 Resetting for Totalization Display	6-7
	6.3.4 Damping Time Constant	6-7

6.3.5	Limiting Current Output During Alarm Occurrence	6-8
6.3.6	Reversing Flow Direction	6-8
6.3.7	Limiting on Current Output	6-8
6.3.8	Forward and Reverse Flow Measurement	6-10
6.3.9	Automatic Two Range Switching	6-11
6.3.10	Alarm Output at Low Flow Limit (Flow Switch)	6-12
6.3.11	Totalization Switch Output	6-13
6.3.12	Alarm Output	6-14
6.3.13	Data Setting Enable / Inhibit	6-14
6.3.14	Procedure of Selecting Special Application Items	6-15
6.3.15	Rate Limit	6-15
6.3.16	Pulsating Flow	6-16
7.	OPERATION VIA BRAIN TERMINAL	7-1
7.1	Operation Via the BT200	7-1
7.1.1	BT200 Connections	7-1
7.1.2	BT200 Keypad Layout	7-2
7.1.3	Major BT200 Key Functions	7-3
7.1.4	Displaying Flow Rate Data	7-5
7.2	Setting Parameters	7-6
7.2.1	Setting Flow Span	7-6
7.2.2	Power Frequency	7-7
7.2.3	Pulse Output (Refer to 6.3.1)	7-7
7.2.4	Display of Internal Totalization Values (Refer to 6.3.2)	7-8
7.2.5	Resetting for Totalization Display (Refer to 6.3.3)	7-8
7.2.6	Damping Time Constant (Refer to 6.3.4)	7-9
7.2.7	Current Output during Alarm Occurrence (Refer to 6.3.5)	7-9
7.2.8	Reversing Flow Direction (Refer to 6.3.6)	7-9
7.2.9	Limiting Current Output (Refer to 6.3.7)	7-9
7.2.10	Forward and Reverse Flow Measurement (Refer to 6.3.8)	7-10
7.2.11	Automatic Two Range Switching (Refer to 6.3.9)	7-11
7.2.12	Alarm Output at Low Flow Limits (Flow Switch) (Refer to 6.3.10)	7-11
7.2.13	Totalization Switch Output (Refer to 6.3.11)	7-12
7.2.14	Alarm Output (Refer to 6.3.12)	7-12
7.2.15	Data Setting Enable / Inhibit (Refer to 6.3.13)	7-13
7.2.16	Procedure of Selecting Special Application Items (Refer to 6.3.14)	7-13
7.2.17	Rate Limit (Refer to 6.3.15)	7-13
7.2.18	Pulsating Flow (Refer to 6.3.16)	7-13
7.2.19	User-Defined Units Via the BT200	7-14
7.2.20	Other Important Points to Note	7-15
8.	ACTUAL OPERATION	8-1
8.1	Pre-Operation Zero Adjustment	8-1
8.1.1	Zero Adjustment Using Data Setting Keys	8-1
8.1.2	Zero Adjustment Via the BT200	8-2
8.2	Self-diagnostics Functions	8-3
8.2.1	Display and Output Status during Alarm Occurrence	8-3
8.2.2	Error Description and Countermeasures	8-3

9. MAINTENANCE	9-1
9.1 Loop Test (Test Output)	9-1
9.1.1 Settings for Test Output Using Data Setting Keys	9-1
9.1.2 Setting for Test Output Via the BT200	9-1
9.2 Fuse Replacement	9-2
9.3 Trouble Shooting	9-2
10. OUTLINE.....	10-1
11. PARAMETER SUMMARY	11-1
12. EXPLOSION PROTECTED TYPE INSTRUMENT	12-1
12.1 CENELEC ATEX (KEMA)	12-1
12.2 FM	12-2
12.3 CSA	12-3
12.4 SAA	12-3
12.5 JIS	12-4
13. PRESSURE EQUIPMENT DIRECTIVE	13-1
INSTALLATION AND OPERATING PRECAUTIONS FOR JIS FLAMEPROOF EQUIPMENT	EX-B03E

1. INTRODUCTION

This instrument has been already adjusted at the factory before shipment.

To ensure correct use of the instrument, please read this manual thoroughly and fully understand how to operate the instrument before operating it.

■ Regarding This Manual

- This manual should be passed on to the end user.
- Before use, read this manual thoroughly to comprehend its contents.
- The contents of this manual may be changed without prior notice.
- All rights reserved. No part of this manual may be reproduced in any form without Yokogawa's written permission.
- Yokogawa makes no warranty of any kind with regard to this material, including, but not limited to, implied warranties of merchantability and suitability for a particular purpose.
- All reasonable effort has been made to ensure the accuracy of the contents of this manual. However, if any errors are found, please inform Yokogawa.
- Yokogawa assumes no responsibilities for this product except as stated in the warranty.
- If the customer or any third party is harmed by the use of this product, Yokogawa assumes no responsibility for any such harm owing to any defects in the product which were not predictable, or for any indirect damages.

■ Safety Precautions

- The following general safety precautions must be observed during all phases of operation, service, and repair of this instrument. Failure to comply with these precautions or with specific WARNINGS given elsewhere in this manual violates safety standards of design, manufacture, and intended use of the instrument. YOKOGAWA Electric Corporation assumes no liability for the customer's failure to comply with these requirements. If this instrument is used in a manner not specified in this manual, the protection provided by this instrument may be impaired.

The following safety symbol marks are used in this manual and instrument;



WARNING

A WARNING sign denotes a hazard. It calls attention to procedure, practice, condition or the like, which, if not correctly performed or adhered to, could result in injury or death of personnel.



CAUTION

A CAUTION sign denotes a hazard. It calls attention to procedure, practice, condition or the like, which, if not correctly performed or adhered to, could result in damage to or destruction of part or all of the product.



IMPORTANT

A IMPORTANT sign denotes an attention to avoid leading to damage to instrument or system failure.



NOTE

A NOTE sign denotes a information for essential understanding of the operation and features.



Protective grounding terminal.



Function grounding terminal. This terminal should not be used as a "Protective grounding terminal".



Alternating current.



Direct current.

■ Warranty

- The guaranteed term of this instrument is described in the quotation. We repair the damages that occurred during the guaranteed term for free.
- Please contact with our sales office when this instrument is damaged.
- If the instrument has trouble, please inform us model code, serial number, and concrete substances or situations. It is preferable to be attached a outline or data.
- We decide after the examination if free repair is available or not.
- Please consent to the followings for causes of damages that are not available as free repair, even if it occurred during the guaranteed term.

A: Unsuitable or insufficient maintenance by the customer.

B: The handling, using, or storage that ignore the design and specifications of the instrument.

C: Unsuitable location that ignore the description in this manual.

D: Remaking or repair by a person except whom we entrust.

E: Unsuitable removing after delivered.

F: A natural disaster (ex. a fire, earthquake, storm and flood, thunderbolt) and external causes.

■ For Safety Using

For safety using the instrument, please give attention mentioned below.



WARNING

(1) Installation

- The instrument must be installed by expert engineer or skilled personnel. The procedures described about INSTALLATION are not permitted for operators.
- The Magnetic Flowmeter is a heavy instrument. Please give attention to prevent that persons are injured by carrying or installing. It is preferable for carrying the instrument to use a cart and be done by two or more persons.
- In case of high process temperature, care should be taken not to burn yourself because the surface of body and case reach a high temperature.
- When removing the instrument from hazardous processes, avoid contact with the fluid and the interior of the flow tube.
- All installation shall comply with local installation requirement and local electrical code.

(2) Wiring

- The instrument must be installed by expert engineer or skilled personnel. The procedures described about WIRING are not permitted for operators.
- Please confirm voltages between the power supply and the instrument before connecting the power cables. And also, please confirm that the cables are not powered before connecting.
- The protective grounding must be connected to the terminal  in order to avoid personal shock hazard.

(3) Operation

- Wait 10 min. after power is turned off, before opening the covers.

(4) Maintenance

- Please do not carry out except being written to a maintenance descriptions. When these procedures are needed, please contact to nearest YOKOGAWA office.
- Care should be taken to prevent the build up of drift, dust or other material on the display glass and data plate. In case of its maintenance, soft and dry cloth is used.

(5) Explosion Protected Type Instrument

- For explosion proof type instrument, the description in Chapter 12 "EXPLOSION PROTECTED TYPE INSTRUMENT" is prior to the other description in this user's manual.
- Only trained persons use this instrument in the industrial location.
- The protective grounding  must be connected to a suitable IS grounding system.
- Take care not to generate mechanical spark when access to the instrument and peripheral devices in hazardous locations.

(6) The Instrument in Compliance with PED

- For the instrument in compliance with PED, the description in Chapter 13 "PRESSURE EQUIPMENT DIRECTIVE" is prior to the other description in this User's Manual.

2. HANDLING PRECAUTIONS

This instrument has been already tested thoroughly at the factory. When the instrument is delivered, please check externals and make sure that no damage occurred during transportation.

In this chapter, handling precautions are described. Please read this chapter thoroughly at first. And please refer to the relative matter about other ones.

If you have any problems or questions, please make contact with Yokogawa sales office.

2.1 Checking Model and Specifications

The model and specifications are shown on the Data Plate. Please confirm the specifications between the instrument that was delivered and the purchase order (refer to the chapter 10. Outline).

Please let us know Model and Serial No. when making contact with Yokogawa sales office.

ADMAG AIE		MAGNETIC FLOW DETECTOR		IM: User's Manual		N200 CE	
MODEL		PULSE OUTPUT		VDC 0.2Amax			
SUFFIX		LINING					
STYLE		MATERIAL					
SIZE	mm	ELECTRODE					
METER	L	MATERIAL					
FACTOR	H	ACCURACY					
SUPPLY	VDC 12.5W	RATING	(JIS B7554)				
VAC ~ 47-63Hz 36VA 12.5W		FLUID TEMP.	°C MAX. (SEE IM)				
FULL SCALE		FLUID PRESS.	-0.1 MPa MIN. (SEE IM)				
CURRENT	mA	AMB. TEMP.	+60°C MAX. (SEE IM)				
OUTPUT	(0-750Ω)	NO.					
YOKOGAWA ◆ Made In Japan							

Figure 2.1 Data Plate

2.2 Accessories

When the instrument is delivered, please make sure that the following accessories are in the package.

- Fuse (250V, 2A time lag) : 1-piece
*The spare fuse is taped to the converter.
- Data sheet : 1-sheet
- Unit labels : 1-sheet
- Centering device (for wafer type) : 1-set
- Plug (for DC power supply only) : 1-piece
- Hexagonal wrench : 1-piece
(for special screw of hazardous duty type converter.)

2.3 Storage Precautions

In case the instrument is expected to be stored over a long term, please give attention to the followings;

- The instrument should be stored in its original packing condition.
- The storage location should be selected according to the following conditions:
 - 1) The location where it is not exposed to rain or water.
 - 2) The location where there is few vibration or shock.
 - 3) Temperature and humidity should be:
Temperature: -20 to 60°C (-4 to 140°F)
Humidity: 5 to 80% RH (no condensation)
Preferable ambient temperature and humidity are 25°C (77°F) and about 65% RH.

2.4 Installation Location Precautions

Please select the installation location considering the following items to ensure long term stable operation of the flow tube.

- Ambient Temperature:
Please avoid to install the instrument at the location where temperature changes continuously. If the location receives radiant heat from the plant, provide heat insulation or improve ventilation.
- Atmospheric Condition:
Please avoid to install the instrument in an corrosive atmosphere. In case of installing in the corrosive atmosphere, please keep ventilating sufficiently and prevent rain from entering the conduit.
- Vibration or shock:
Please avoid to install the instrument at the location where there is heavy vibration or shock.

2.5 Converter Reorientation Precautions

Please do not change the converter orientation at the customer's site. If the converter reorientation is required, please contact Yokogawa office or service center.

3. COMPONENT NAMES

Wafer Type

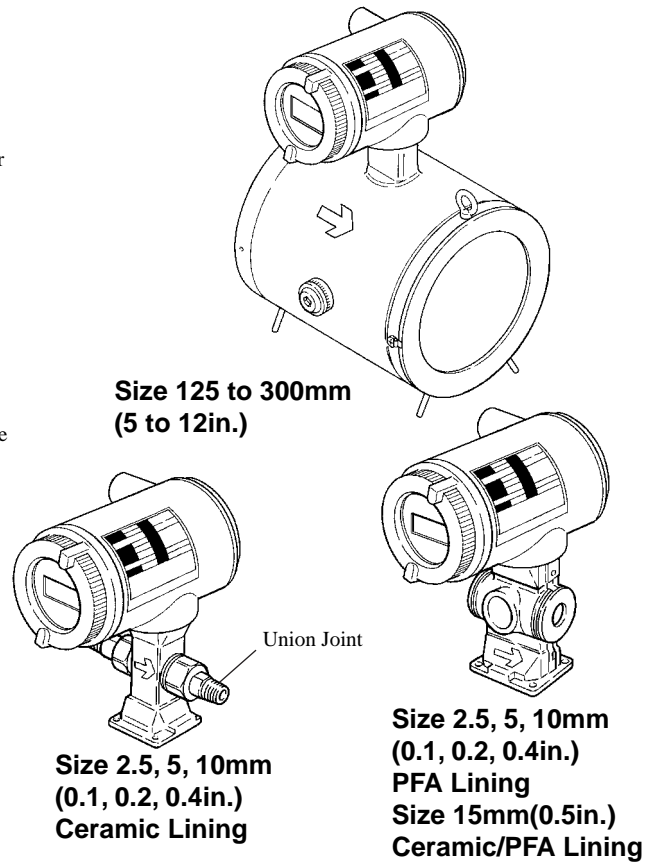
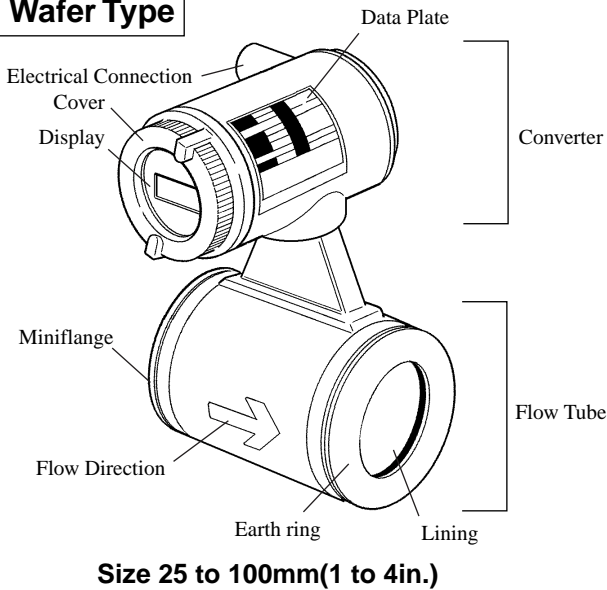

Flange Type

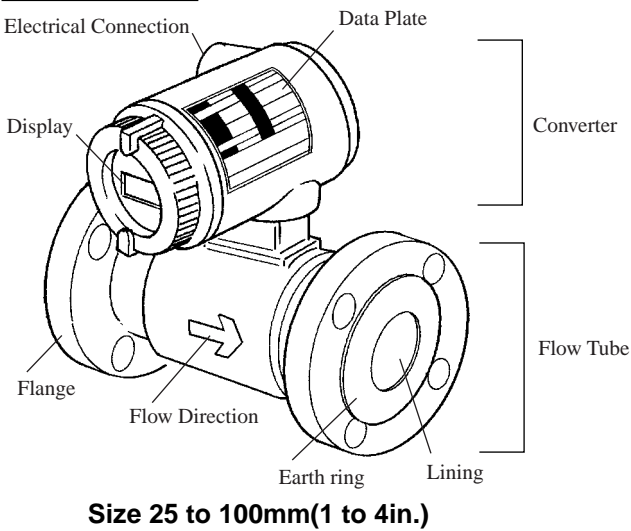

Sanitary Type

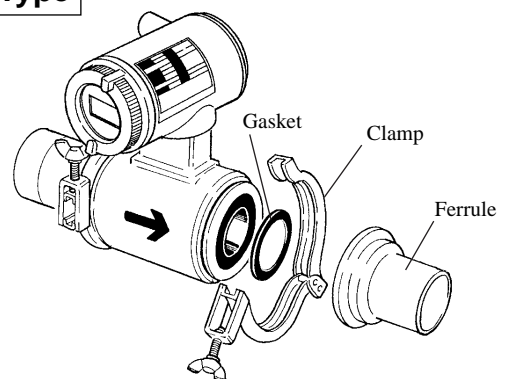
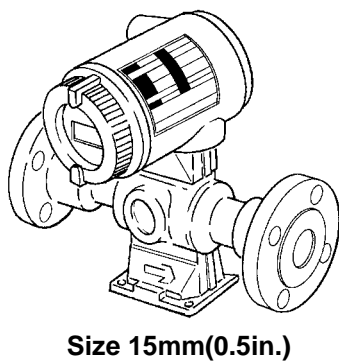

4. INSTALLATION



WARNING

This instrument must be installed by expert engineer or skilled personnel. The procedures described in this chapter are not permitted for operators.

4.1 Piping Design Precautions



IMPORTANT

Please design the correct piping referring to the followings to prevent damage for flowmeter and to keep correct measuring.

(1) Location



IMPORTANT

Please install the flowmeter to the location where it is not exposed to direct sunlight and ambient temperature is -10 to $+60^{\circ}\text{C}$ (14 to 140°F).

* The minimum ambient temperature -20°C is available only for these sizes 40 to 100mm with SUS304 flange.

(2) Noise Rejection



IMPORTANT

The instrument should be installed away from large electrical motors, transformers and other power sources in order to avoid interference with the measurement.

(3) Length of Straight Run

To keep accurate measuring, JIS B7554 “Electro Magnetic Flowmeters” explains about upstream piping condition of Magnetic Flowmeters.

We recommend to our customers about the piping conditions shown in Figure 4.1.1 based on JIS B7554 and our piping condition test data.

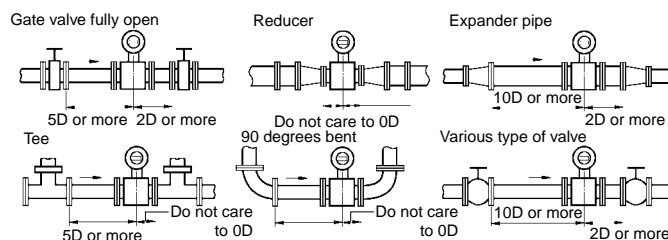

Figure 4.1.1 Minimum Length of Required Straight Run



NOTE

- Nothing must be inserted or installed in the metering pipe than may interfere with the magnetic field, induced signal voltages, and flow velocity distribution.
- These straight runs may not be required on the downstream side flowmeter. However, if the downstream valve or other fittings cause channeling on the upstream side, provide a straight run of 2 D to 3 D on the downstream side.

(4) Liquid Conductivity



IMPORTANT

Please avoid to install the flowmeter at location where liquid conductivity is likely to be non-uniform. Because it is possible to have bad influences to the flow indication by non-uniform conductivity when a chemical liquid is injected from upstream side close to the flowmeter. When this occurs, it is recommended that chemical application ports are installed on the downstream side of the flowmeter. In case chemicals must be added upstream side, please keep the pipe length enough so that liquid is properly mixed.

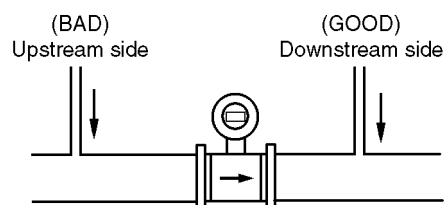

Figure 4.1.2 Chemical Injection

(5) Liquid Sealing Compound



IMPORTANT

Please give attention in using Liquid Sealing Compound to the piping, because it brings bad influences to measurement by flowing out and cover the surfaces of electrode and earth-ring.

(6) Service Area

Please select the location where there is enough area to service installing, wiring, overhaul, etc.

(7) Bypass Line

It is recommended to install the Bypass Line to facilitate maintenance and zero adjustment.

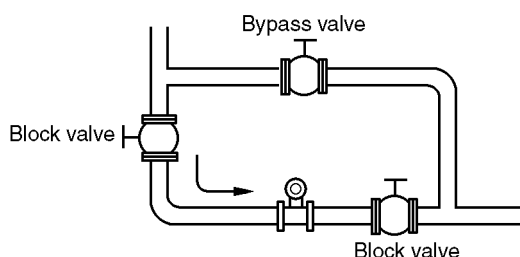

Figure 4.1.3 Bypass Line

(8) Supporting the Flowmeter



CAUTION

Please avoid to support only the flowmeter, but fix pipes at first and support the flowmeter by pipes to protect the flowmeter from forces caused by vibration, shock, expansion and contraction through piping.
For small sized flowmeters, please provide a mounting base so that the flowmeters are fixed in the piping. See the section 4.3 Mounting.

(9) Piping Condition



IMPORTANT

The piping should be designed so that a full pipe is maintained at all times to prevent loss of signal and erroneous readings.

Please design the piping that a fluid is always filled in the pipes. The Vertical Mounting is effective for fluids that is easily separate or slurry settles within pipes. In this case, please flow a fluid from bottom to up.

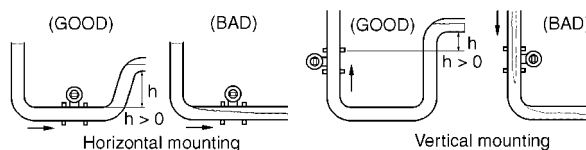

Figure 4.1.4 Filling the Pipe with Liquid

(10) No Air Bubbles



IMPORTANT

Please give attention to prevent bad influences or measuring errors from air bubbles that gathers inside measuring pipes.

In case the fluid includes air bubbles, please design the piping that prevent to gather air bubbles. In case valves are installed upstream of the flowmeter, it is possible that a valve causes air bubbles, please install the flowmeter upstream side of a valve.

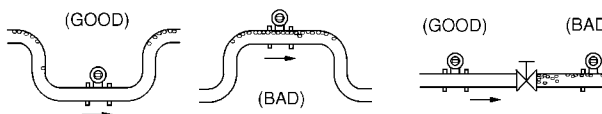

Figure 4.1.5 Avoiding Air Bubbles

(11) Mounting Direction



IMPORTANT

When the electrodes are vertical to ground, the electrode is covered with air bubbles at upper side or slurry at downside, and it may cause the measuring errors.
Please be sure to mount the converter upper side of piping to prevent water penetration into converter case.

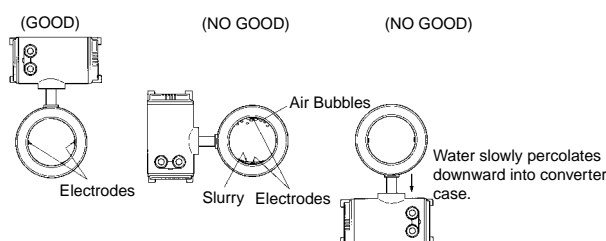

Figure 4.1.6 Mounting Direction

(12) Grounding

IMPORTANT

Improper grounding can have an adverse affect on the flow measurement. Please ensure that the instrument is properly grounded.

The electromotive force of the magnetic flowmeter is minute and it is easy to be affected by noise. And also that reference electric potential is the same as the measuring fluid potential. Therefore, the reference electric potential (terminal potential) of the Flow Tube and the Converter/Amplifier also need to be the same as the measuring fluid. And moreover, that the potential must be the same with ground.

Please be sure to ground according to Figure 4.1.7.

600V vinyl insulated electric cable
(2mm in diameter or larger)

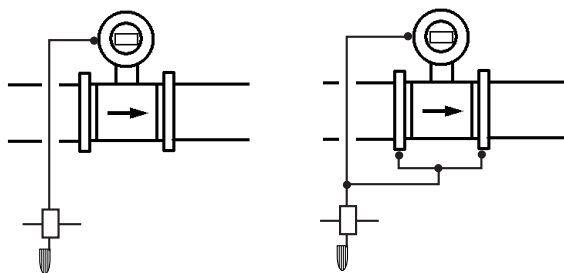
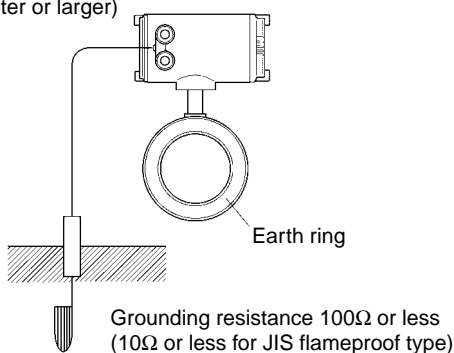

In case earth rings are used.

In case earth rings are not used.
(Available only for metal piping)

Note: See "4.4.1 Protective Grounding" for information on protective grounding.

Figure 4.1.7 Grounding

4.2 Handling Precautions

WARNING

The Magnetic Flowmeter is a heavy instrument. Please be careful to prevent persons from injuring when it is handled.

4.2.1 General Precautions

(1) Precaution for Carrying

The Magnetic Flowmeter is packed tightly. When it is unpacked, please give attention to prevent damages to the flowmeter. And to prevent the accident during carry to the installing location, please carry it near the location keeping packed as it delivered.

CAUTION

In case the Magnetic Flowmeter lifts up, please refer to Figure 4.2.1. Please never lift up by using a bar through the flowmeter. It damages liner severely.

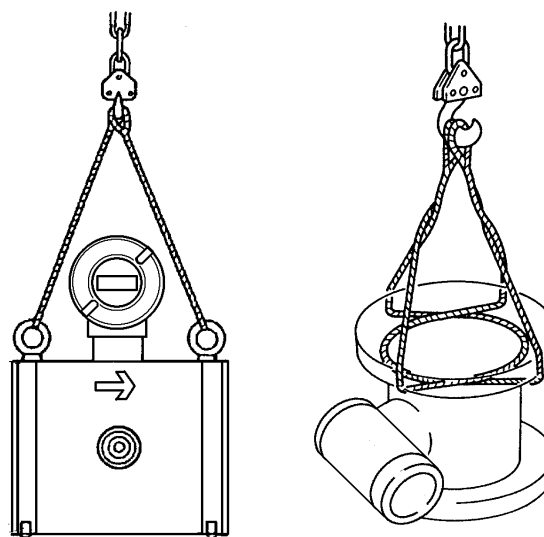

Horizontal Lifting

Vertical Lifting Sling Rigging Method

Figure 4.2.1 Lifting Flowmeters

(2) Precaution for Shock**CAUTION**

Care should be taken not to drop the flowmeter or subject it to excessive shock. This may lead to liner damage which will cause inaccurate readings.

(3) Flange Protection Covers**IMPORTANT**

Please keep the protection cover (ex. corrugated paper or anything possible to protect) attached with flange except when mounting to the pipe.

(4) Terminal Box Cover**IMPORTANT**

Please never leave the terminal box cover open until wiring to prevent insulation deterioration.

(5) Long-term Non-use**IMPORTANT**

It is not preferable to leave the flowmeter for long term non-use after installation. In case the flowmeter is compelled to do that, please take care of the flowmeter by the followings.

- Confirmation of Sealing Condition for the Flowmeter.
Please confirm the sealing conditions of the terminal box screw and wiring ports.
In case of the Conduit Piping, please provide the drain plugs or waterproof glands to it to prevent that moisture or water penetrates into the flowmeter through the conduit.
- Regular Inspections
Please inspect the sealing condition (as above mentioned) and inside of the terminal box. And when it is suspect that water penetration into the inside flowmeter (ex. rain fall), please inspect when it happened.

4.2.2 Flow Tube Piping**CAUTION**

Mis-aligned or slanted piping can lead to leakage and damage to flanges.

- Please correct mis-alignment or slanted piping and improper distance between mounting flanges before install the flowmeter. (Please refer to Figure 4.2.2)
- Inside a pipeline which is newly installed, some foreign substances (such as welding scrap or wood chips) may exist. Please remove them by flushing piping before mounting the flowmeter.

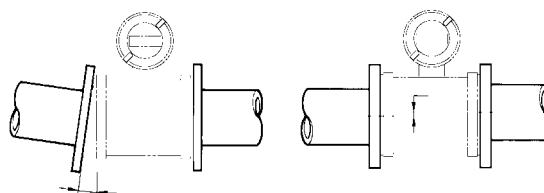
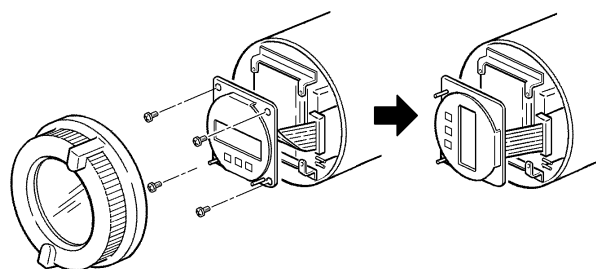

Figure 4.2.2 Slant and Mis-alignment of Flowmeter Piping

4.2.3 Alteration of LCD Display Orientation

LCD display orientation can be altered according to piping configurations if horizontal or vertical, just by removing four screws, adjusting unit orientation and fixing the screws tightly again as shown in Figure 4.2.3.

**NOTE**

Orientation of display unit is limited as either way of the two shown in this figure.

Figure 4.2.3 Procedure of Altering LCD Display Orientation

4.3 Mounting

4.3.1 Nominal Diameter 2.5 mm (0.1in.) to 10 mm (0.4in.) Union Joint Type

 **NOTE**

Please ensure to use the attached connecting fittings.

Ceramic linings with a diameter of 2.5, 5 or 10 mm are connected using union joints.

Use the connecting fittings according to the table below. Depending on whether the fitting is to be welded to or screwed on to the piping.

Table 4.3.1 Fitting Dimensions

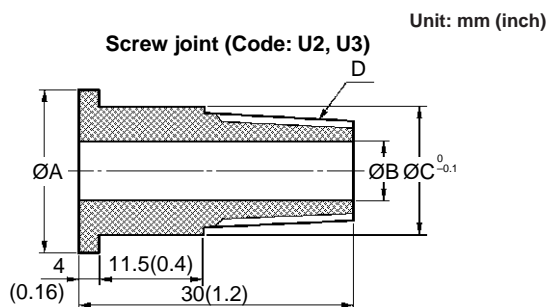

Size mm(inch)	Code	A	B	C	D
2.5(0.1)	U2	22(0.87)	8(0.31)	18.5(0.73)	R1/4(PT1/4)
	U3	22(0.87)	8(0.31)	18.5(0.73)	NPT1/4
5(0.2)	U2	22(0.87)	8(0.31)	18.5(0.73)	R1/4(PT1/4)
	U3	22(0.87)	8(0.31)	18.5(0.73)	NPT1/4
10(0.4)	U2	25(0.98)	10(0.39)	22.5(0.89)	R3/8(PT3/8)
	U3	25(0.98)	10(0.39)	22.5(0.89)	NPT3/8

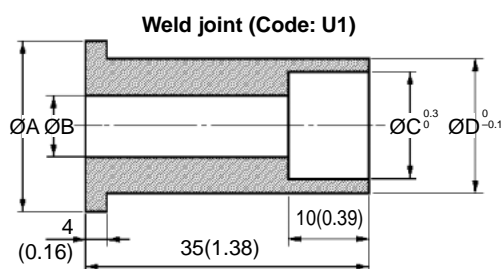

Size mm(inch)	Code	A	B	C	D
2.5(0.1)	U1	22(0.87)	8(0.31)	14.3(0.56)	18.5(0.73)
5(0.2)	U1	22(0.87)	8(0.31)	14.3(0.56)	18.5(0.73)
10(0.4)	U1	25(0.98)	10(0.39)	17.8(0.70)	22.5(0.89)

T040301.EPS

(1) Mounting Direction

Please mount the Magnetic Flowmeter matching the flow direction of the fluid to be measured with the direction of the arrow mark on the flowmeter.

 **IMPORTANT**

If it is impossible to match the direction, please never remodel by changing direction of the converter. In case the measuring fluid flows against the arrow direction, please refer to the section 6.3.6 or 7.2.8 Reversing Flow Direction.

(2) Connecting Process Piping

Weld or screw the connecting fittings to the process piping.

 **IMPORTANT**

- Please be sure to pass the connecting fittings through the union joint nuts in advance. Then connect the connecting fitting to the piping by screwing or welding the connecting fitting to the piping (see Figure 4.3.1).
- In case of weld joint type, please pay attention the welding condition to avoid deforming piping or making the stagnant portion of the fluid; joint preparation, level difference in butt joint, welding current.

(3) Positioning Flowmeter

Install the magnetic flowmeter on a mounting base and position it so that the center axis of the flowmeter is aligned with that of the piping. Then mount the flowmeter to union joint nuts by screwing the nuts to the connecting ports of the flowmeter.

 **CAUTION**

The ceramic pipe will be damaged if they are tightened when they are not properly aligned.

(4) Tightening Nuts

 **CAUTION**

Tighten the union joint nuts according to Torque Values in Table 4.3.2 using a torque wrench. As the gasket material is Fluorocarbon PTFE, it is possible that nuts may loose by it's character as time passes. Please tighten the nuts regularly. The table below shows the tightening torque values. Be sure to use gasket : t=1.5 attached.

4.3.2 Nominal Diameter 2.5mm (0.1in.) to 40mm (1.5in.) Wafer Type

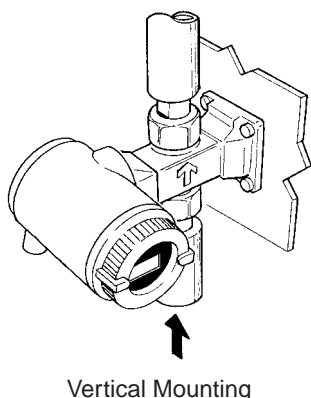
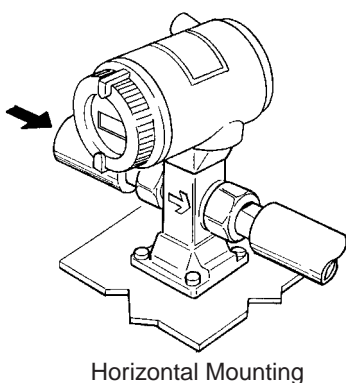
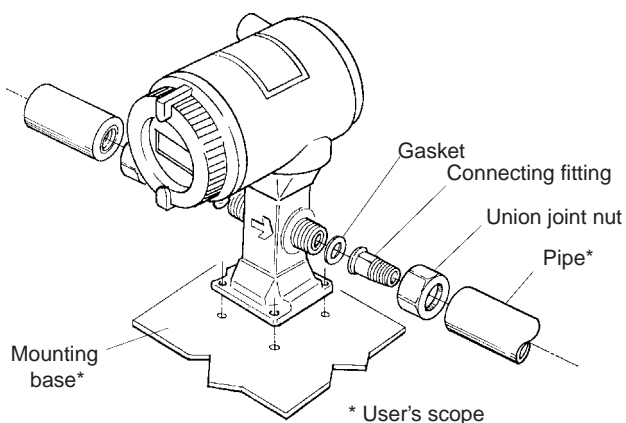

Figure 4.3.1 Mounting Procedure (Size: 2.5 mm(0.1in.) to 10 mm(0.4in.))

Table 4.3.2 Tightening Torque

Size: mm(inch)	Tightening Torque N-m {kgf-cm} [in-lbf]
2.5(0.1)	Max.12{122}[106]
5(0.2)	Max.12{122}[106]
10(0.4)	Max.18{183}[160]

T040302.EPS

IMPORTANT

Please use appropriate bolts and nuts according to process connection. In case stud type of through bolts are used, be sure outside diameter of a shank is smaller than a thread ridge's one. Please use compressed non-asbestos fiber gasket, PTFE gasket or the gasket which has equal elasticity. In case of optional code/FRG, please use rubber gasket or others which has equal elasticity. Be sure the inner diameter of the gasket does not protrude to inner piping. (Refer to Table 4.3.8)

(1) Mounting Direction

Please mount the Magnetic Flowmeter matching the flow direction of the fluid to be measured with the direction of the arrow mark on the flowmeter.

IMPORTANT

If it is impossible to match the direction, please never remodel by changing direction of the converter. In case the measuring fluid flows against the arrow direction, please refer to the section 6.3.6 or 7.2.8 Reversing Flow Direction.

(2) Mounting Centering Devices

To keep concentricity of the Flowmeter with pipes, please mount centering devices on the Mini-Flanges of the Flowmeter.

Please give attention to the nominal diameter and flange ratings of the centering devices.

(3) Positioning Flowmeter

Please pass two through-bolts to adjacent holes of both flanges and mount the Flowmeter, and pass other through-bolts to other holes. (Refer to Figure 4.3.2/ 4.3.3) In case stud type of through-bolts are used, position them coming in contact centering devices with thread of bolts.

(4) Tightening Nuts

Please tighten the bolts according to Torque Values in Table 4.3.3. In case of PVC piping, please select optional code /FRG, use rubber gasket and tighten with the torque value in Table 4.3.4.

CAUTION

In case of PFA lining type, as the lining material is Fluorocarbon PFA, it is possible that nuts may loose by its character as time passes. Please tighten the nuts regularly.
Please be sure to tighten the bolts following prescribed torque values. Please tighten the flange bolts diagonally with the same torque values, step by step up to the prescribed torque value.

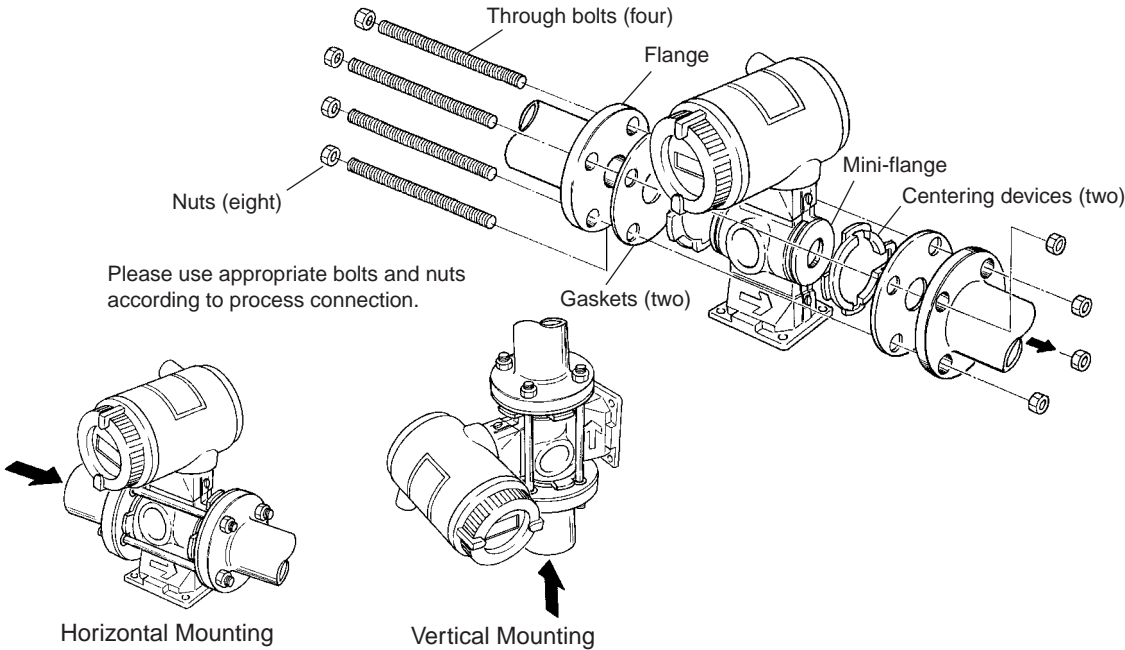

Figure 4.3.2 Mounting Procedure (Size: 2.5 mm(0.1in.) to 15 mm(0.5in.))

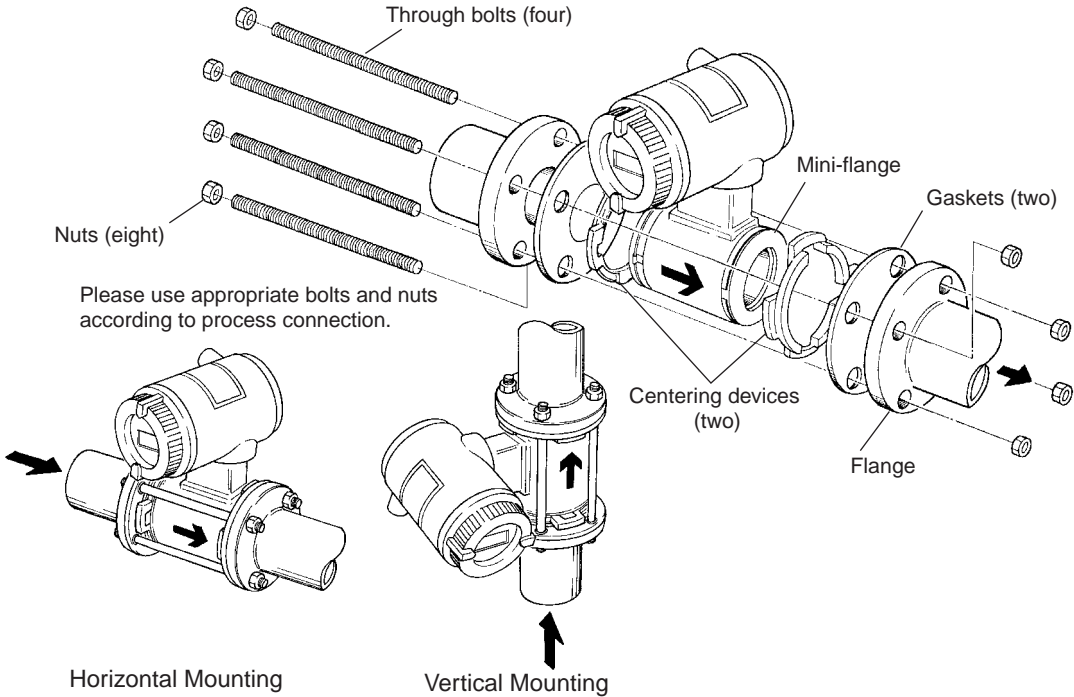

Figure 4.3.3 Mounting Procedure (Size: 25 mm(1in.), 40 mm(1.5in.))

Table 4.3.3 Wafer Type Tightening Torque Values for Metal Piping

Tightening Torque Values for PFA lining / Polyurethane lining Type N-m {kgf-cm} [in-lbf]						
Size mm(inch)	Flange Rating	JIS		ANSI		DIN
		10K	20K	150	300	PN10/16/40
2.5(0.1), 5(0.2) 10(0.4), 15(0.5)		6 to 9	6 to 9	6 to 9	6 to 9	6 to 8
		{61 to 92}	{61 to 92}	{61 to 92}	{61 to 92}	{62 to 86}
		[53 to 80]	[53 to 80]	[53 to 80]	[53 to 80]	[54 to 75]
25(1)		15 to 22	15 to 22	12 to 18	15 to 22	13 to 17
		{153 to 224}	{153 to 224}	{122 to 184}	{153 to 224}	{129 to 169}
		[133 to 195]	[133 to 195]	[106 to 159]	[133 to 195]	[112 to 147]
40(1.5)		21 to 32	21 to 32	17 to 26	25 to 38	23 to 31
		{214 to 327}	{214 to 327}	{173 to 265}	{255 to 388}	{239 to 319}
		[186 to 283]	[186 to 283]	[150 to 230]	[221 to 336]	[208 to 277]

Maximum Tightening Torque Values for Ceramic lining Type N-m {kgf-cm} [in-lbf]						
Size mm(inch)	Flange Rating	JIS		ANSI		DIN
		10K	20K	150	300	PN10/16/40
15(0.5)		14	14	14	14	11
		{143}	{143}	{143}	{143}	{110}
		[124]	[124]	[124]	[124]	[96]
25(1)		30	30	22	30	25
		{306}	{306}	{224}	{306}	{250}
		[265]	[265]	[195]	[265]	[217]
40(1.5)		44	44	33	51	50
		{449}	{449}	{337}	{520}	{500}
		[389]	[389]	[292]	[451]	[435]

*Please use compressed non-asbestos fiber gasket, PTFE gasket or the gasket which has equal elasticity.

T040303.EPS

Table 4.3.4 Wafer Type Tightening Torque Values for PVC Piping

Tightening Torque Values for PFA lining / Polyurethane lining Type N-m {kgf-cm} [in-lbf]						
Size mm(inch)	Flange Rating	JIS		ANSI		DIN
		10K	20K	150	300	PN10/16/40
2.5(0.1), 5(0.2) 10(0.4), 15(0.5)		2.0	—	2.1	—	1.8
		{20}	—	{21}	—	{18}
		[18]	—	[19]	—	[16]
25(1)		5.2	—	4.2	—	3.6
		{53}	—	{43}	—	{37}
		[46]	—	[37]	—	[32]
40(1.5)		7.4	—	6.0	—	6.7
		{76}	—	{61}	—	{68}
		[65]	—	[53]	—	[59]

Maximum Tightening Torque Values for Ceramic Type N-m {kgf-cm} [in-lbf]						
Size mm(inch)	Flange Rating	JIS		ANSI		DIN
		10K	20K	150	300	PN10/16/40
15(0.5)		1.3	—	1.3	—	1.3
		{13}	—	{13}	—	{13}
		[12]	—	[12]	—	[12]
25(1)		3.5	—	2.8	—	2.8
		{36}	—	{29}	—	{29}
		[31]	—	[25]	—	[25]
40(1.5)		5.7	—	4.6	—	6.1
		{58}	—	{47}	—	{62}
		[50]	—	[41]	—	[54]

*Please select optional code/FRG and use rubber gasket or others which has equal elasticity.

T040304.EPS

4.3.3 Nominal Diameter 50 mm(2in.) to 300 mm(12in.) Wafer Type



IMPORTANT

Please use appropriate bolts and nuts according to process connection. In case stud type of through bolts are used, be sure outside diameter of a shank is smaller than a thread ridge's one. Please use compressed non-asbestos fiber gasket, PTFE gasket or the gasket which has equal elasticity. In case of optional code/FRG, please use rubber gasket or others which has equal elasticity. Be sure the inner diameter of the gasket does not protrude to inner piping. (Refer to Table 4.3.8)

(1) Mounting Direction

Please mount the Magnetic Flowmeter matching the flow direction of the fluid to be measured with the direction of the arrow mark on the flowmeter.



IMPORTANT

If it is impossible to match the direction, please never remodel to change direction of the converter. In case the measuring fluid flows against the arrow direction, please refer to the section 6.3.6 or 7.2.8 Reversing Flow Direction.

(2) Mounting Centering Devices

To keep concentricity between the Flowmeter and pipes, centering devices must be used. Pass two through-bolts through the four centering devices (two for each) and lower adjacent holes of both flanges. (Refer to Figure 4.3.4)

Please give attention to the nominal size and flange ratings of the centering devices. (Refer to Table 4.3.7)

(3) Positioning Flowmeter

Position the Flowmeter coming in contact four centering devices with Mini-Flanges. At this time, pay attention to avoid four centering devices come in contact with Housing. In case stud type of through-bolts are used, position them coming in contact four centering devices with thread of the bolts. (Refer to Figure 4.3.4) After positioning the Flowmeter, pass remaining through-bolts to remaining holes.



NOTE

When installing a size 150mm with JIS F12 (JIS75M) flange, please displace in circumferential direction slightly because the cover of electrode chamber will interfere against the bolts.

(4) Tightening Nuts

Please tighten the bolts according to Torque Values in Table 4.3.5. In case of PVC piping, please select optional code/FRG, use rubber gasket and tighten with the torque value in Table 4.3.6.



CAUTION

In case of PFA lining type as the lining material is Fluorocarbon PFA, it is possible that nuts loose by its character as time passes. Please tighten the nuts regularly.

Please be sure to tighten the bolts following prescribed torque values. Please tighten the flange bolts diagonally with the same torque values, step by step up to the prescribed torque value.

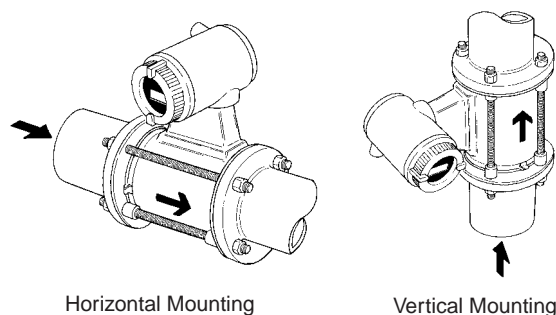
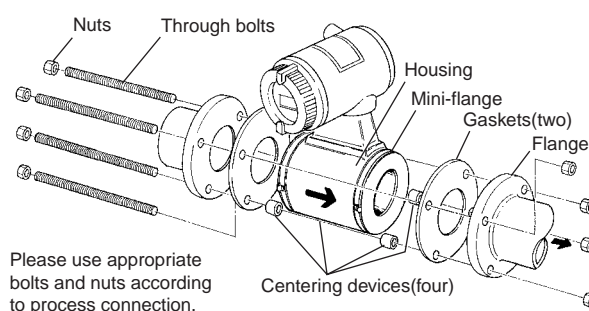

Figure 4.3.4 Mounting Procedure

Table 4.3.5 Wafer Type Tightening Torque Values for Metal Piping

Tightening Torque Values for PFA lining / Polyurethane lining Type N-m (kgf-cm) [in-lbf]									
Size mm(inch)	Flange Rating	JIS		ANSI		DIN			JIS G3451 F12
		10K	20K	150	300	PN10	PN16	PN40	
50(2)		28 to 42 {286 to 429} [248 to 372]	14 to 21 {143 to 214} [124 to 186]	28 to 42 {286 to 429} [248 to 372]	14 to 21 {143 to 214} [124 to 186]	—	32 to 41 {327 to 419} [284 to 364]	32 to 41 {327 to 419} [284 to 364]	—
65(2.5)		52 to 60 {530 to 610} [460 to 531]	—	52 to 60 {530 to 610} [460 to 531]	—	—	52 to 60 {530 to 610} [460 to 531]	—	—
80(3)		21 to 31 {214 to 316} [186 to 274]	26 to 39 {265 to 398} [230 to 345]	41 to 61 {418 to 622} [363 to 540]	25 to 37 {255 to 378} [221 to 327]	—	21 to 31 {214 to 316} [186 to 274]	—	41 to 62 {418 to 633} [363 to 549]
100(4)		35 to 51 {357 to 520} [310 to 451]	43 to 64 {439 to 653} [381 to 566]	35 to 51 {357 to 520} [310 to 451]	41 to 61 {418 to 622} [363 to 540]	—	35 to 52 {357 to 531} [310 to 460]	—	68 to 102 {694 to 1041} [602 to 903]
125(5)		62 to 75 {630 to 760} [549 to 664]	—	60 to 72 {610 to 730} [531 to 637]	—	—	52 to 60 {530 to 610} [460 to 531]	—	71 to 80 {720 to 810} [628 to 708]
150(6)		65 to 94 {663 to 959} [575 to 832]	43 to 68 {439 to 694} [381 to 602]	63 to 89 {643 to 908} [558 to 788]	41 to 60 {418 to 612} [363 to 531]	65 to 94 {663 to 959} [575 to 832]	65 to 94 {663 to 959} [575 to 832]	—	68 to 100 {694 to 1020} [602 to 885]
200(8)		57 to 84 {582 to 857} [504 to 743]	61 to 92 {622 to 939} [540 to 814]	93 to 120 {949 to 1224} [823 to 1062]	65 to 93 {663 to 949} [575 to 823]	94 to 125 {959 to 1276} [832 to 1106]	58 to 84 {592 to 857} [513 to 743]	—	69 to 101 {704 to 1031} [611 to 894]
250(10)		98 to 128 {996 to 1307} [867 to 1133]	—	89 to 130 {909 to 1329} [788 to 1150]	—	91 to 117 {924 to 1195} [805 to 1035]	—	—	139 to 176 {1416 to 1792} [1230 to 1558]
300(12)		85 to 108 {871 to 1098} [752 to 956]	—	106 to 146 {1083 to 1489} [938 to 1292]	—	108 to 131 {1103 to 1339} [956 to 1159]	—	—	131 to 158 {1337 to 1606} [1159 to 1398]

Maximum Tightening Torque Values for Ceramic lining Type N-m (kgf-cm) [in-lbf]									
Size mm(inch)	Flange Rating	JIS		ANSI		DIN PN			JIS G3451 F12
		10K	20K	150	300	PN10	PN16	PN40	
50(2)		50 {510} [442]	27 {276} [239]	50 {510} [442]	27 {276} [239]	—	63 {643} [558]	63 {643} [558]	—
80(3)		36 {367} [319]	44 {449} [389]	75 {765} [664]	44 {449} [389]	—	36 {367} [319]	—	80 {816} [708]
100(4)		48 {490} [425]	58 {592} [513]	49 {500} [434]	56 {571} [496]	—	48 {490} [425]	—	105 {1071} [929]
150(6)		110 {1126} [979]	78 {799} [695]	92 {943} [820]	61 {618} [537]	—	107 {1093} [950]	—	84 {857} [743]
200(8)		97 {986} [857]	105 {1069} [930]	134 {1372} [1193]	101 {1028} [894]	143 {1460} [1270]	94 {957} [832]	—	102 {1041} [903]

*Please use compressed non-asbestos fiber gasket, PTFE gasket or the gasket which has equal elasticity.

T040306.EPS

Table 4.3.6 Wafer Type Tightening Torque Values for PVC Piping

Tightening Torque Values for PFA lining / Polyurethane lining Type N-m (kgf-cm) [in-lbf]									
Size mm(inch)	Flange Rating	JIS		ANSI		DIN			JIS G3451 F12(75M)
		10K	20K	150	300	PN10	PN16	PN40	
50(2)		9.8 {100} [87]	—	9.8 {100} [87]	—	—	9.1 {93} [81]	9.1 {93} [81]	—
80(3)		7.2 {73} [64]	—	14.4 {147} [127]	—	—	7.2 {73} [64]	—	14.4 {147} [127]
100(4)		12.2 {124} [108]	—	12.2 {124} [108]	—	—	12.2 {124} [108]	—	24.4 {249} [216]
150(6)		21.4 {218} [189]	—	20.5 {209} [181]	—	21.4 {218} [189]	21.4 {218} [189]	—	23.4 {239} [207]
200(8)		19.3 {197} [171]	—	27.6 {282} [244]	—	28.9 {295} [256]	19.3 {197} [171]	—	31.6 {322} [280]

Maximum Tightening Torque Values for Ceramic lining Type N-m (kgf-cm) [in-lbf]									
Size mm(inch)	Flange Rating	JIS		ANSI		DIN			JIS G3451 F12(75M)
		10K	20K	150	300	PN10	PN16	PN40	
50(2)		8.2 {84} [73]	—	8.2 {84} [73]	—	—	8.9 {91} [79]	8.9 {91} [79]	—
80(3)		6.2 {63} [55]	—	12.4 {127} [110]	—	—	6.2 {63} [55]	—	12.3 {126} [109]
100(4)		8.0 {82} [71]	—	8.1 {83} [72]	—	—	8.0 {82} [71]	—	16.1 {164} [142]
150(6)		19.8 {202} [175]	—	18.9 {193} [167]	—	19.8 {202} [175]	19.8 {202} [175]	—	21.6 {220} [191]
200(8)		17.5 {179} [155]	—	25.1 {256} [222]	—	26.2 {267} [232]	17.5 {179} [155]	—	28.7 {293} [254]

*Please select optional code/FRG and use rubber gasket or others which has equal elasticity.

T040306.EPS

Table 4.3.7 Centering Device Identification

Lining	Flange Rating	JIS 10K	JIS 20K	JIS G3451 F12	ANSI 150	ANSI 300	DIN PN 10/16	DIN PN 40
	mm(inch)							
PFA, Poly- urethane	50(2)	B	B	—	B	F	F	F
	65(2.5)	B	—	—	B	—	F	—
	80(3)	B	F	H	F	C	G	—
	100(4)	B	F	H	C	H	F	—
	125(5)	G	—	H	C	—	G	—
	150(6)	C	D	D	C	E	C	—
	200(8)	C	D	D	D	E	C	—
	250(10)	C	—	D	N	—	C	—
300(12)	C	—	D	P	—	C	—	
Ceramics	50(2)	B	B	—	B	F	F	F
	80(3)	B	F	H	F	C	G	—
	100(4)	B	F	H	C	H	F	—
	150(6)	B	C	G	B	D	B	—
	200(8)	B	C	C	G	J	B	—

T040307.EPS

*Each Centering Device is engraved a character as identification.

Table 4.3.8 Earth Ring Inside Diameter

Unit: mm(inch)

Size	PFA/Polyurethane lining	Ceramic lining
2.5(0.1)	φ15(0.6)	—
5(0.2)	φ15(0.6)	—
10(1.4)	φ15(0.6)	—
15(0.5)	φ15(0.6)	φ15(0.6)
25(1)	φ27(1.1)	φ27(1.1)
40(1.5)	φ40(1.6)	φ40(1.6)
50(2)	φ52(2.1)	φ52(2.1)
65(2.5)	φ63.5(2.5)	—
80(3)	φ81(3.2)	φ81(3.2)
100(4)	φ98(3.9)	φ98(3.9)
125(5)	φ118.6(4.7)	—
150(6)	φ140.7(5.6)	φ144(5.7)
200(8)	φ188.9(7.5)	φ192(7.6)
250(10)	Wafer; φ243.7(9.6), Flange; φ239.1(9.5)	—
300(12)	Wafer; φ294.7(11.6), Flange; φ291.3(11.5)	—
350(14)	φ323.4(12.8)	—
400(16)	φ373.5(14.8)	—

T040308.EPS

* Please ensure that the I.D. of the gasket does not protrude into the I.D. of the Earth Ring.
(This dimension is also applied when no earth ring is used)

4.3.4 Nominal Diameter 15 mm (0.5in.) to 400 mm (16in.) Flange Type



IMPORTANT

Please use appropriate bolts and nuts according to process connection. Please use compressed non-asbestos fiber gasket, PTFE gasket or the gasket which has equal elasticity. In case of optional code/FRG, please use rubber gasket or others which has equal elasticity. Be sure the inner diameter of the gasket does not protrude to inner piping. (Refer to Table 4.3.8)

(1) Mounting Direction

Please mount the Magnetic Flowmeter matching the flow direction of the fluid to be measured with the direction of the arrow mark on the flowmeter.



IMPORTANT

If it is impossible to match the direction, please never remodel to change direction of the converter. In case the measuring fluid flows against the arrow direction, please refer to the section 6.3.6 or 7.2.8 Reversing Flow Direction.

(2) Tightening Nuts

Please tighten the bolts according to Torque Values in Table 4.3.9. In case of PVC piping, please select optional code/FRG, use rubber gasket and tighten with the torque value in Table 4.3.10.



CAUTION

In case of PFA lining type as the lining material is Fluorocarbon PFA, it is possible that bolts loose by its character as time passes. Please tighten the nuts regularly.

Please be sure to tighten the bolts following prescribed torque values. Please tighten the flange bolts diagonally with the same torque values, step by step up to the prescribed torque value.

Please use appropriate bolts and nuts according to process connection.

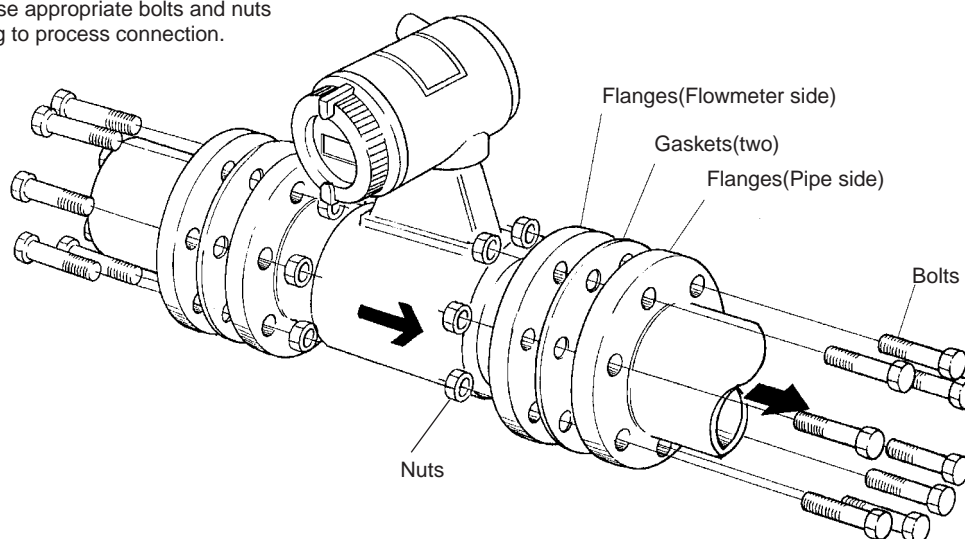

Figure 4.3.5 Mounting Procedure (Size: 15 mm (0.5in.) to 400 mm (16in.))

Table 4.3.9 Flange Type Tightening Torque Values for Metal Piping in N-m{kgf-cm} [in-lbf]

Size mm(inch)	Flange Rating	JIS		ANSI		DIN			JIS G3451 F12(75M)
		10K	20K	150	300	PN10	PN16	PN40	
15(0.5)		3 to 5 {31 to 51} [27 to 44]	3 to 5 {31 to 51} [27 to 44]	3 to 5 {31 to 51} [27 to 44]	3 to 5 {31 to 51} [27 to 44]	—	6 to 8 {62 to 89} [54 to 77]	6 to 8 {62 to 89} [54 to 77]	—
25(1)		8 to 13 {82 to 133} [71 to 115]	8 to 13 {82 to 133} [71 to 115]	6 to 10 {61 to 102} [53 to 88]	8 to 13 {82 to 133} [71 to 115]	—	12 to 17 {124 to 169} [108 to 147]	12 to 17 {124 to 169} [108 to 147]	—
40(1.5)		18 to 26 {184 to 265} [159 to 230]	18 to 26 {184 to 265} [159 to 230]	15 to 21 {153 to 214} [133 to 186]	21 to 31 {214 to 316} [186 to 274]	—	22 to 31 {226 to 319} [197 to 277]	22 to 31 {226 to 319} [197 to 277]	—
50(2)		22 to 31 {224 to 316} [195 to 274]	11 to 16 {112 to 163} [97 to 142]	23 to 31 {235 to 316} [204 to 274]	11 to 16 {112 to 163} [97 to 142]	—	30 to 41 {308 to 419} [268 to 364]	30 to 41 {308 to 419} [268 to 364]	—
80(3)		15 to 22 {153 to 224} [133 to 195]	18 to 27 {184 to 276} [159 to 239]	35 to 43 {357 to 439} [310 to 381]	18 to 26 {184 to 265} [159 to 230]	—	16 to 22 {163 to 224} [142 to 195]	—	33 to 47 {337 to 480} [292 to 416]
100(4)		21 to 35 {214 to 357} [186 to 310]	25 to 44 {255 to 449} [221 to 389]	22 to 35 {224 to 357} [195 to 310]	25 to 42 {255 to 429} [221 to 372]	—	21 to 35 {214 to 357} [186 to 310]	—	47 to 75 {480 to 765} [416 to 664]
150(6)		65 to 94 {663 to 959} [575 to 832]	43 to 68 {439 to 694} [381 to 602]	63 to 89 {643 to 908} [558 to 788]	41 to 59 {418 to 602} [363 to 522]	65 to 94 {663 to 959} [575 to 832]	65 to 94 {663 to 959} [575 to 832]	—	65 to 100 {663 to 1020} [575 to 885]
200(8)		57 to 84 {582 to 857} [504 to 743]	61 to 92 {622 to 939} [540 to 814]	93 to 120 {949 to 1224} [823 to 1062]	65 to 93 {663 to 949} [575 to 823]	94 to 125 {959 to 1276} [832 to 1106]	58 to 84 {592 to 857} [513 to 743]	—	69 to 101 {704 to 1031} [611 to 894]
250(10)		142 to 174 {1449 to 1776} [1257 to 1540]	154 to 182 {1571 to 1857} [1363 to 1611]	145 to 177 {1480 to 1806} [1283 to 1566]	126 to 151 {1286 to 1541} [1115 to 1336]	136 to 164 {1388 to 1673} [1204 to 1451]	154 to 175 {1571 to 1786} [1363 to 1549]	—	215 to 270 {2194 to 2755} [1903 to 2389]
300(12)		114 to 138 {1163 to 1408} [1009 to 1221]	125 to 145 {1276 to 1480} [1106 to 1283]	164 to 187 {1673 to 1908} [1451 to 1655]	154 to 180 {1571 to 1837} [1363 to 1593]	155 to 199 {1582 to 2031} [1372 to 1761]	175 to 213 {1786 to 2173} [1549 to 1885]	—	190 to 249 {1939 to 2541} [1681 to 2204]
350(14)		158 to 183 {1612 to 1867} [1398 to 1619]	—	245 to 284 {2500 to 2898} [2168 to 2513]	—	152 to 192 {1551 to 1959} [1345 to 1699]	—	—	274 to 325 {2796 to 3316} [2425 to 2876]
400(16)		243 to 261 {2480 to 2663} [2150 to 2310]	—	253 to 275 {2582 to 2806} [2239 to 2434]	—	248 to 331 {2531 to 3378} [2195 to 2929]	—	—	313 to 395 {3194 to 4031} [2770 to 3496]

*Please use compressed non-asbestos fiber gasket, PTFE gasket or the gasket which has equal elasticity.

T040309.EPS

Table 4.3.10 Flange Type Tightening Torque Values for PVC Piping in N-m{kgf-cm} [in-lbf]

Size mm(inch)	Flange Rating	JIS		ANSI		DIN			JIS G3451 F12(75M)
		10K	20K	150	300	PN10	PN16	PN40	
15(0.5)		1.1 {11} [10]	—	1.1 {11} [10]	—	—	1.7 {17} [15]	1.7 {17} [15]	—
25(1)		2.9 {30} [26]	—	2.3 {23} [20]	—	—	3.5 {36} [31]	3.5 {36} [31]	—
40(1.5)		5.9 {60} [52]	—	4.7 {48} [42]	—	—	6.4 {65} [56]	6.4 {65} [56]	—
50(2)		7.2 {73} [64]	—	7.2 {73} [64]	—	—	8.7 {88} [76]	8.7 {88} [76]	—
80(3)		4.9 {50} [43]	—	9.9 {101} [88]	—	—	4.9 {50} [43]	—	9.9 {101} [88]
100(4)		8.1 {83} [72]	—	8.2 {84} [73]	—	—	8.1 {83} [72]	—	16.3 {166} [144]
150(6)		29.8 {304} [264]	—	28.5 {291} [252]	—	29.8 {304} [264]	29.8 {304} [264]	—	32.6 {33} [288]
200(8)		26.3 {268} [233]	—	37.7 {385} [334]	—	39.4 {4.2} [349]	26.3 {268} [233]	—	43.1 {440} [381]

*Please select optional code/FRG and use rubber gasket or others which has equal elasticity.

T040310.EPS

4.3.5 Mounting Procedure for Sanitary Type

The sanitary type is mounted using ISO(IDF) clamps.

(1) Mounting Direction

Please mount the Magnetic Flowmeter matching the flow direction of the fluid to be measured with the direction of the arrow mark on the flowmeter.



IMPORTANT

If it is impossible to match the direction, please never remodel to change direction of the terminal box. In case the measuring fluid flows against the arrow direction, please refer to the section 6.3.6 or 7.2.8 Reversing Flow Direction.

(2) Welding of Mating Ferrule to Piping



IMPORTANT

Weld the attached ferrules to the piping. Please pay attention to the welding condition to avoid deforming piping or making the stagnant portion of the fluid; joint preparation, level difference in butt joint, welding current.

(3) Mounting Gasket

Mount the attached gasket so it fits into the groove on the ferrule.

(4) Positioning Flowmeter

Position the flowmeter between the mating ferrule.

(5) Tightening Clamp

Mount the clamp so they cover the flowmeter and mating ferrule tapered part.

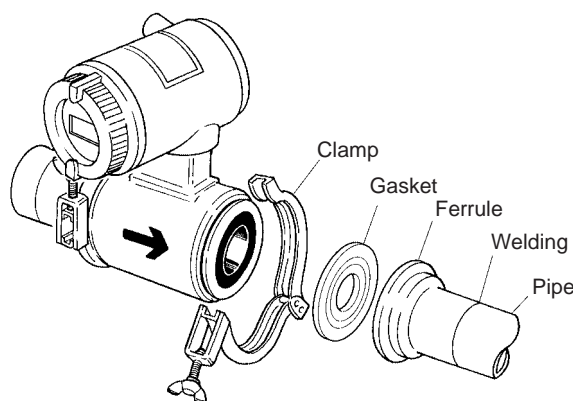

Figure 4.3.8 Mounting Procedure

4.4 Wiring Precautions



CAUTION

Please confirm that all connections are correct before applying power to the instrument. Improper wiring may damage the flowmeter.

The external signal wirings are connected into the terminal inside the converter. Please connect to each terminal (Please refer to Figure 4.4.1) by taking off a cover backside the converter.

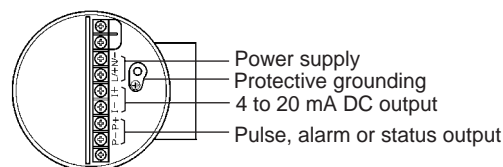

Terminal Symbols	Description
\oplus	Protective grounding
N- L+	Power Supply
I+ I-	Current Output 4 to 20mA DC
P+ P-	Pulse, alarm or status output

Figure 4.4.1 Terminal

4.4.1 Protective Grounding



CAUTION

Please be sure to connect protective grounding of ADMAG AE with cable of 2mm² or larger cross section in order to avoid the electrical shock to the operators and maintenance engineers and prevent the influence of external noise. And further connect the grounding wire to the \oplus mark (100Ω or less).

4.4.2 General Precautions

Please give attention to the followings in wiring.



CAUTION

- Please pay attention to avoid the cable is bended excessively.
- In case the ambient temperature exceeds 50°C(122°F), please use heat-resistant cables with maximum allowable temperature of 70°C(158°F) or above for JIS flameproof type.
- Please do not connect cables outdoors in case of rain to prevent damages from dew formation and to keep insulation inside the terminal box of the flowmeter.
- The all cable ends are to be provided with round crimp-on terminal.
- The power cables and signal cables must be routed in separate steel conduit tubes or flexible tubes.(except 4-core 24VDC cable wiring.)
- When waterproof glands, union equipped waterproof glands are used, the glands must be properly tightened to keep the box watertight.
- Please install a external switch or circuit breaker as a means of power off (capacitance; 15A, conform to IEC947-1 and IEC947-3). The preferable location is either near the instrument or other places to easy operation. Furthermore, please indicate "power off equipment" on the those external switch or circuit breaker.
- Please be sure to fully tighten the terminal box cover before the power is turned on.
- Please be sure to turn off the power before opening the terminal box cover.
- In case of DC power supply, a plug is attached. When 4-core cable is used, please put that plug into unused electrical connection port.

4.4.3 Power and Output Cables

Power cable:

- Crimp-on Terminal
- Green/Yellow covered conductors shall be used only for connection to PROTECTIVE CONDUCTOR TERMINALS.
- Conform to IEC227, IEC245 or equivalent national authorization.

Output cable:

- Please use Polyvinyl chloride insulated and sheathed control cables (JIS C3401) or Polyvinyl chloride insulated and sheathed portable power cables (JIS C3312) or equivalents.

Outer diameter:

- 6.5 to 12mm in diameter (10.5 or 11.5mm for /ECG, /ECU; 8.5 to 11mm for /G11, /G12)

Nominal cross section:

- Single wire; 0.5 to 2.5mm² , Stranded wire; 0.5 to 2.5mm²

4.4.4 DC Connections

(1)Connecting Power Supply



IMPORTANT

In case of 24VDC power supply, AC power supplies or reversed polarities cannot be connected. It will cause the fuse to burn out.

(2)Supplied Voltage Rating



IMPORTANT

In case of 24VDC power supply, the specification for the supply voltage is 24VDC (-15 to +20%), but the input voltage of the converter drops due to cable resistance so it should be used within the following range.

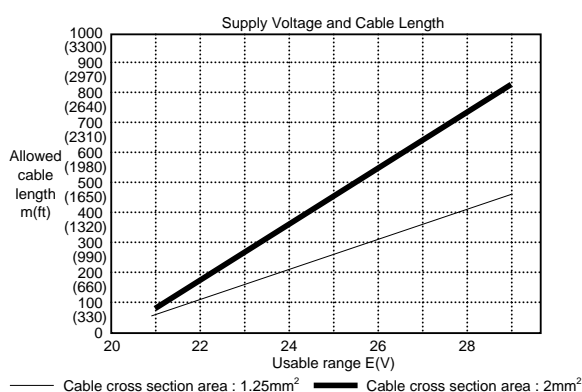

(3)Setting Power Supply Frequency



IMPORTANT

In case of 24VDC power supply, the frequency of the power supply has to be adjusted. Please adjust for the local power frequency. The power supply frequency is set in parameter B12 (or Power freq for HART). Refer to 6.2 or 7.5.2 for data setting procedure.

4.4.5 Wiring Ports

Please select the most suitable standard of wiring procedure for the wiring ports by customer's own.

(1)Using the Waterproof Gland



IMPORTANT

To prevent water or condensate from entering the converter housing, waterproof glands are recommended. Do not over-tighten the glands or damage to the cables may result. Tightness of the gland can be checked by confirming that the cable is held firmly in place.

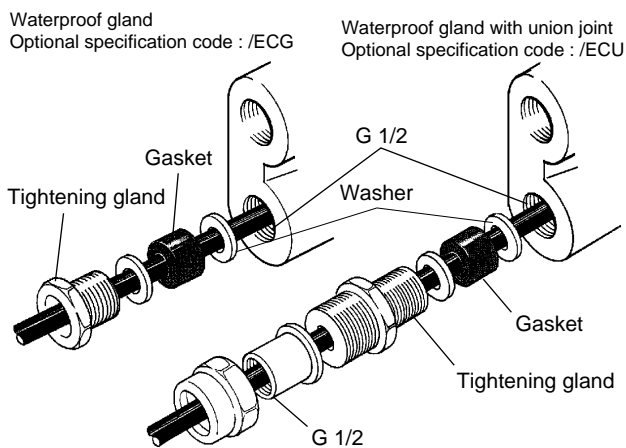

Figure 4.4.2 Waterproof Gland

(2)Conduit Wiring

In case of conduit wiring, please use the waterproof gland to prevent water flowing through the conduit pipe into the wiring connection.

Please slope the conduit pipe down, and install a drain valve at the low end of the vertical pipe.

Please open the drain valve regularly.

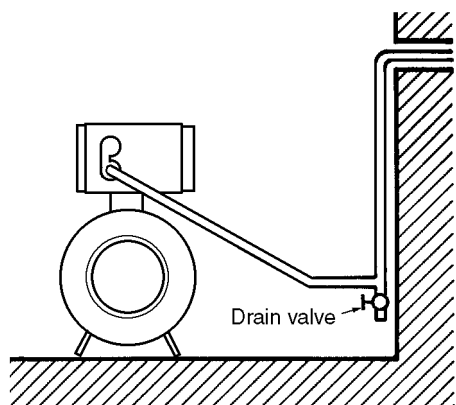

Figure 4.4.3 Conduit Wiring

4.4.6 Connecting to External instruments

CAUTION

All the devices to be connected to current output and pulse output must be conformed to CSA1010, CSA950, or IEC950.

(1)Analog Signal Output(4 to 20mADC)

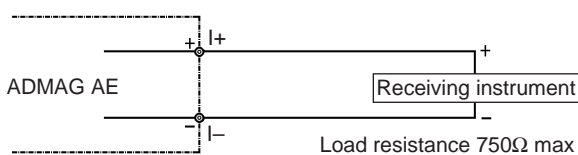

Figure 4.4.4 Connection for Analog Signal Output

(2)Pulse Output

IMPORTANT

Please give attention to voltage and polarity in wiring, because it is transistor contact(insulation type).

- In case of the filtering constant of Electric Counter is more than the pulse width, it makes signal decreases and can not be calculated correctly.
- In case of input impedance of electric counter is large inductive noise from power supply bring bad influence to measurement. To calculate correctly, it is recommended to use shield cable or to make input impedance small enough within the limits of pulse output of flowmeter.

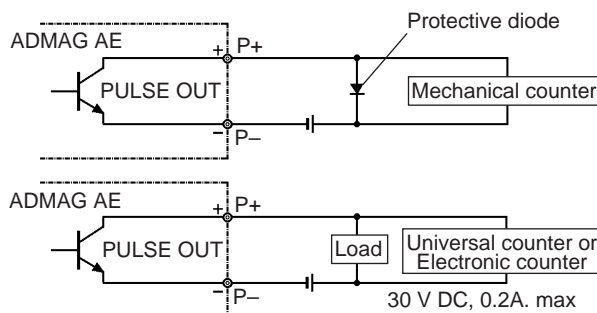

Figure 4.4.5 Pulse Output Connection

(3)Alarm Output

IMPORTANT

This is a transistor contact(insulated type) so attention must be paid to voltage and polarity when making connections.

This output can not switch an AC load. To do this, another relay (see the figure below) is required.

* The alarm output works from "close"(Normal) to "open"(Alarm).

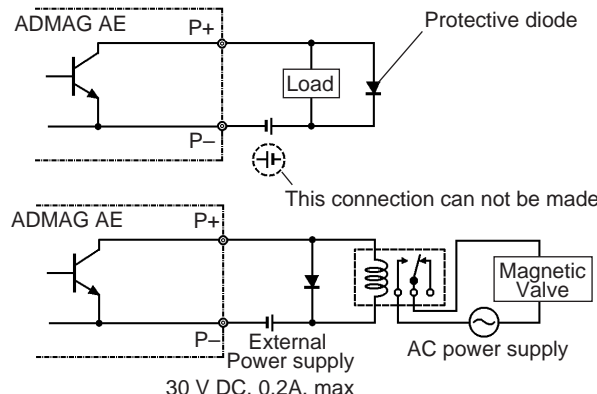

Figure 4.4.6 Alarm Output Connection

5. BASIC OPERATING PROCEDURES

All data settings can be performed with the three keys on the front panel (SET, SHIFT and INC) or using a handheld BRAIN (BT) terminal.

The following sections describe basic data configurations and how to use the three panel keys. (See chapter 7 for information on BT operations.)

5.1 Liquid Crystal Display

Figure 5.1 shows the configuration of the ADMAG AE display panel (if equipped).

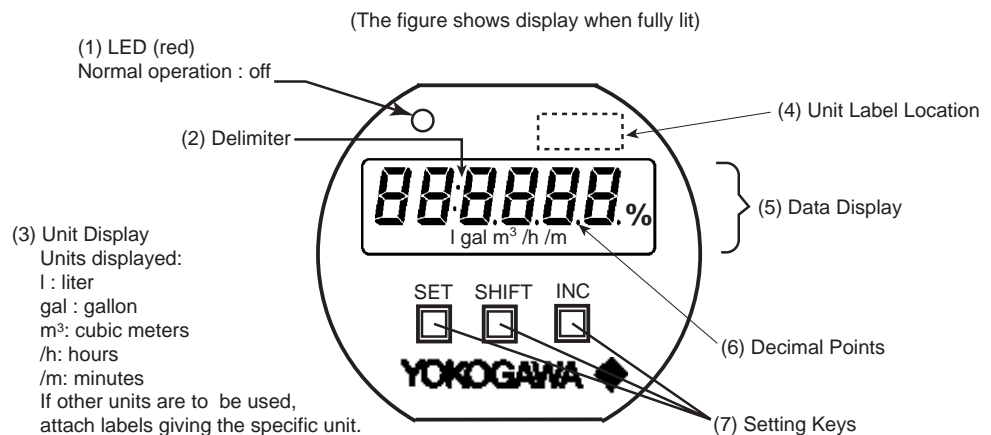
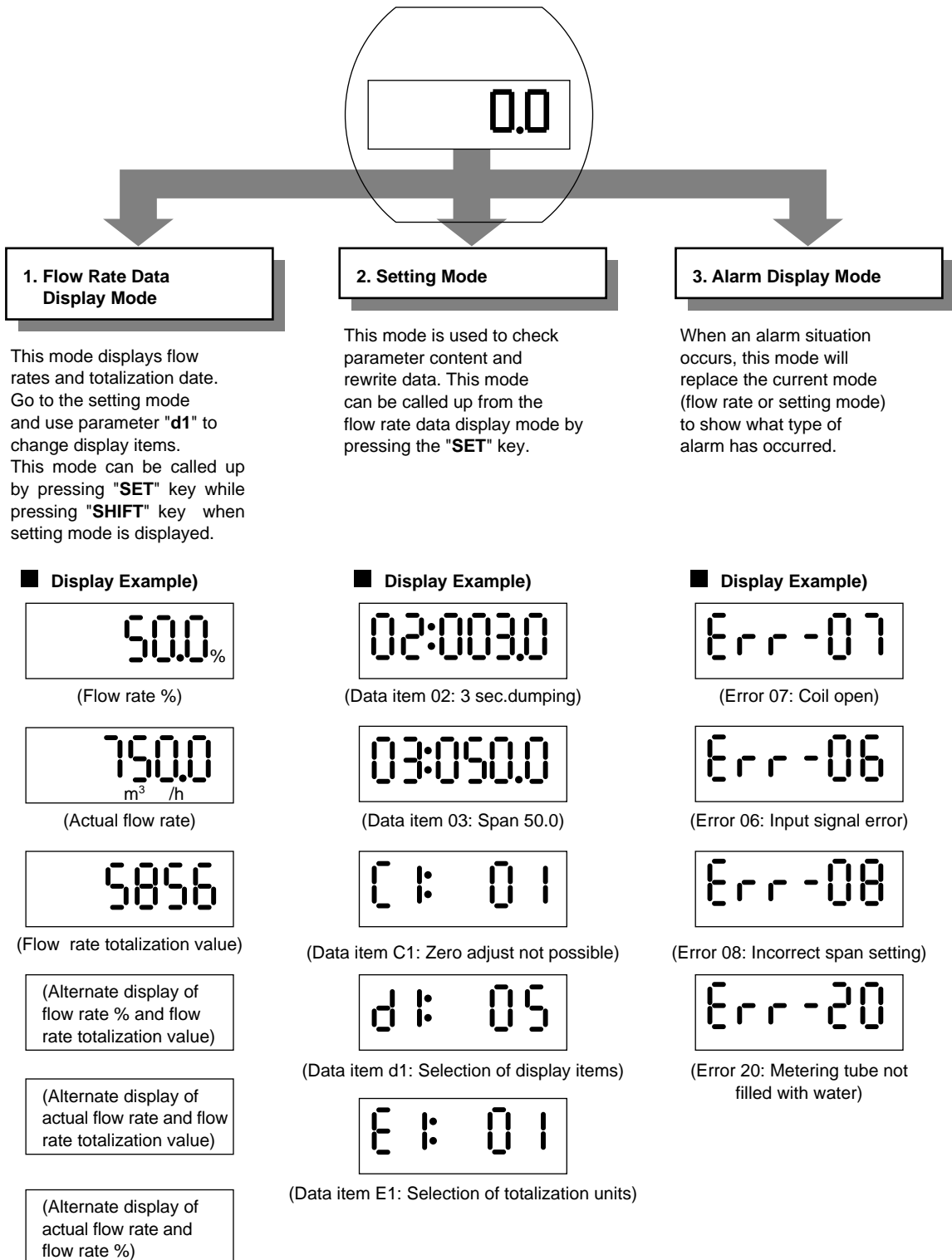

Figure5.1 Configuration of Display

- | | |
|-------------------------|--|
| (1) LED (red) | : This LED is off during normal operation and flashes when an alarm condition has occurred. |
| (2) Delimiter | : The delimiter " : " (colon) indicates that the displayed data is in setting mode. |
| (3) Unit Display | : Displays flow rate units. In order to display other units, the required unit label should be selected from the provided data sheets and attached as shown. |
| (4) Unit Label Location | : To display units not on the LCD, select the required label from the provided data sheets and attach it here. |
| (5) Data Display | : Displays flow rate data, setting data and type of alarm generated. |
| (6) Decimal Point | : Displays decimal point in the data |
| (7) Setting Keys | : These keys are used to change flow rate data displays and type of setting data. |



5.2 Types of Display Data

Three major types of data are displayed.





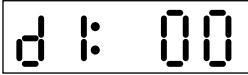
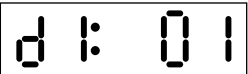
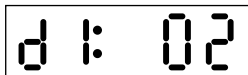

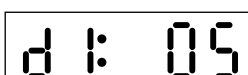
5.2.1 Flow Rate Data Display Mode

- The flow rate data display mode indicates instantaneous flow and totalized flow values.
The ADMAG AE can display 12 types of flow rate data.
- This function can be set in the parameter "d1" of the flow converter.
- For changing from setting mode to flow rate data display mode, press "SET" key while pressing "SHIFT" key.
- When a BT is used, call up the "D01 DISP SELECT" parameter to select functions.

Display item	Content	ADMAG AE Setting	BT Setting
Forward Flow Rate %	Instantaneous flow rate is displayed within a range of -8(or -108) to 108 for the span.		D01 : DISP SELECT RATE(%)
Actual forward Flow Rate	The actual meter rate of instantaneous flow rate is displayed.(See note 1.) The decimal place is the same as for the span setting. However,since a decimal point set at the most significant bit cannot be displayed. It is automatically shifted 1 digit to the right. (BT setting of 0.0001 is displayed as 0.000 on the ADMAG.)		D01 : DISP SELECT RATE
Forward flowrate totalization values	Display forward flow rate totalization value		D01 : DISP SELECT FOR.TOTAL
Reverse flowrate totalization values	Display reverse flow rate totalization value		D01 : DISP SELECT REV.TOTAL
Differential Between the forward and reverse totalization values	Differential totalization, between Forward-totalization and reverse totalization, is displayed.		D01 : DISP SELECT DIF. TOTAL
Alternate display of forward flowrate % and forward flowrate totalization values	Display alternately between display of "RATE (%)" and "FOR. TTL" every 4 second interval.		D01 : DISP SELECT RATE%/FOR.TTL

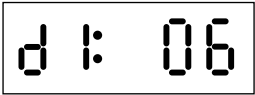
Note 1 : The LCD can display the following combination of units (by selecting a parameter)
Units other than those shown below can be displayed by attaching the provided unit labels .
l (liters) /h, l (liters) /m, m³/h, m³/m, gal/h, gal/m

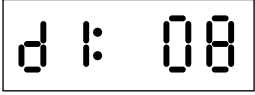
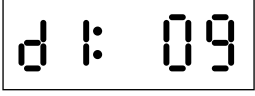
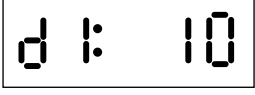
5. BASIC OPERATING PROCEDURES

Display item	Content	ADMAG AE Setting	BT Setting
Alternate display of actual forward flowrate and flowrate totalization values	Display alternately between display of "RATE" and "FOR. TTL" every 4 second interval.		D01 : DISP SELECT RATE/FOR.TTL
Alternate display of actual forward flowrate and forward flowrate (%)	Display alternately between display of "RATE" and "RATE(%)" every 4 second interval.		D01 : DISP SELECT RATE/RATE(%)
Alternate display of forward flowrate (%) and reverse totalization values	Display alternately between display of "RATE(%)" and "REV. TTL" every 4 second interval.		D01 : DISP SELECT RATE(%) /REV.TTL
Alternate display of forward flowrate and reverse flowrate totalization values	Display alternately between display of "RATE" and "REV. TTL" every 4 second interval.		D01 : DISP SELECT RATE/REV.TTL
Alternate display of forward flowrate (%) and differential between the forward and reverse totalization values	Display alternately between display of "RATE(%)" and "DIF. TTL" every 4 second interval.		D01 : DISP SELECT RATE(%) /DIF.TTL
Alternate display of forward flowrate and differential between the forward and reverse totalization values	Display alternately between display of "RATE" and "DIF. TTL" every 4 second interval.		D01 : DISP SELECT RATE/DIF.TTL

(1) Changes in Flow Data Display Items

- Shows how the display changes when the flow converter switches are pressed.
- See chapter 7 for information on changes using the BT200.

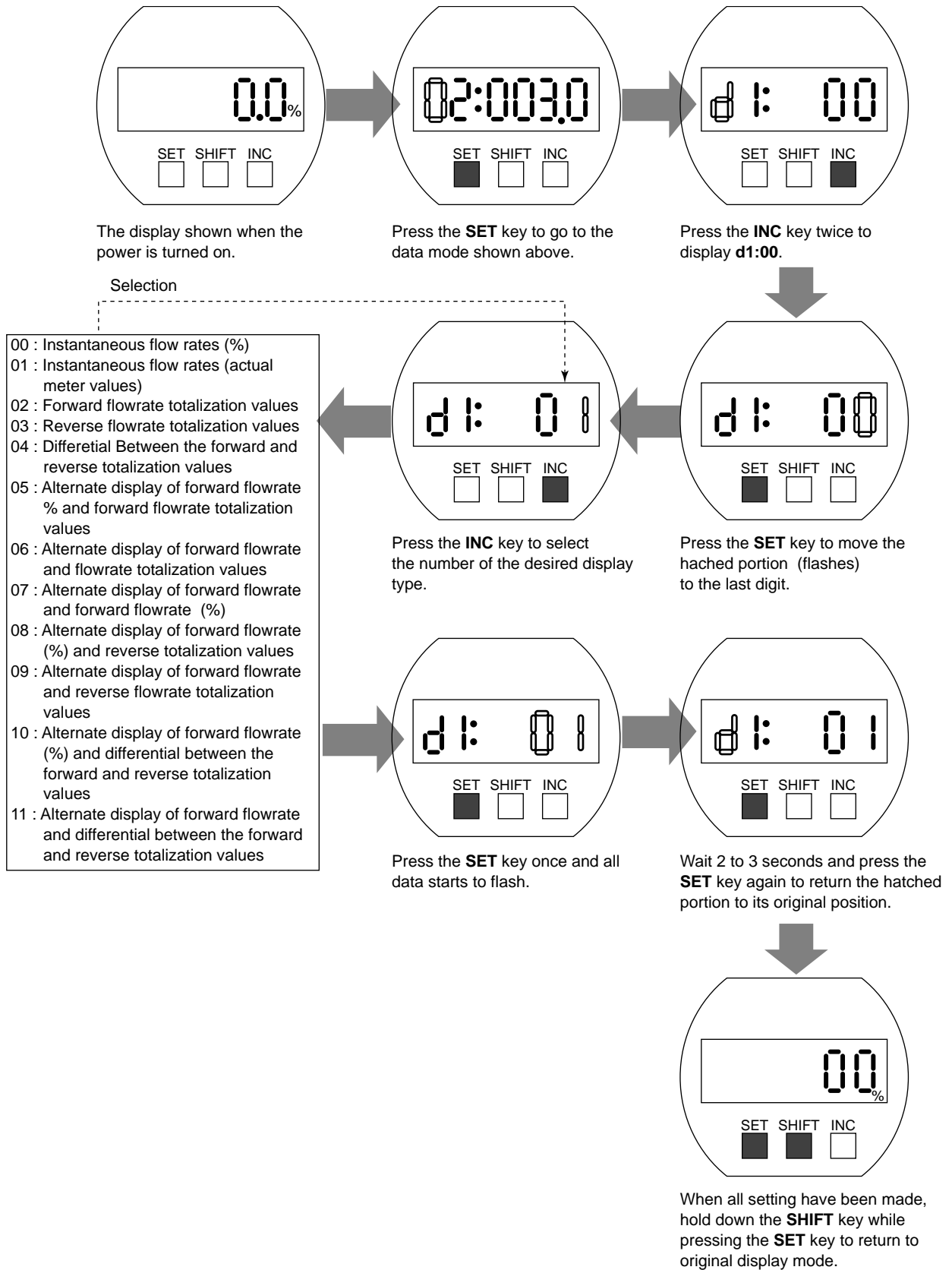

5.2.2 Setting Mode

- The setting mode is used for checking parameters and rewriting data.
- The following is an overview of the setting mode. See Section 6 "Function and Data Settings" for detailed information.

(1) Structure of Setting Mode Display

- The display consists of two areas ; two digits to the left of the colon and four digits to the right of it.
- Two types of data can be entered : direct entry of numerals and entry of desired data items using codes.
Refer to "Parameter list" in chapter 12 for information on how to change settings.

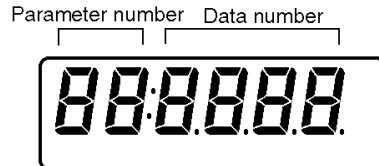

(2) Procedures for Setting and Changing Data

Example of parameter change : Changing the span (number 03) from 1.000 to 1.200

Item	Display	Content
① Switch to "Setting Mode"	<p style="text-align: center;">SET SHIFT INC ■ □ □</p>	Press the SET key to go from the flow rate data display to the setting mode. The delimiter ":" is displayed to indicate that the mode has been switched.
② Parameter Selection	<p style="text-align: center;">SET SHIFT INC □ ■ □</p>	Press the SHIFT key to move the flashing segment (the selected item)
	<p style="text-align: center;">SET SHIFT INC □ □ ■</p>	Use the INC key to change the items displayed in the flashing segment (the selected item). * Parameter 03 contains 5-digit data which cannot be displayed as shown on the left but has to be scrolled.
③ Data Rewrite	<p style="text-align: center;">SET SHIFT INC ■ □ □</p>	Use the SET key to move the flashing segment (the selected item) to the most significant location of the data area.
	<p style="text-align: center;">SET SHIFT INC □ ■ □</p>	Use the SHIFT key to move the flashing segment (the selected item) within the data area.
	<p style="text-align: center;">SET SHIFT INC □ □ ■</p>	Use the INC key to change the data area (numeric data) in the flashing segment (the selected item).

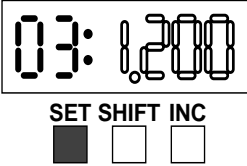
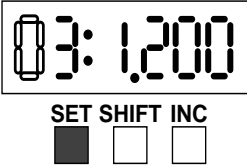
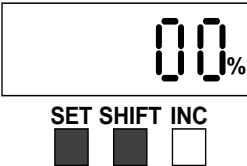

---Continued---

Item	Display	Content
④ Data Input	 <p>SET SHIFT INC ■ □ □ First time</p>  <p>SET SHIFT INC ■ □ □ Second time</p>	<p>Press the SET key twice to enter data. (All data will start flashing when the key is pressed the first time. Then wait 2 to 3 seconds before pressing the key the second time.)</p>
⑤ Switching to Flow Data Entry	 <p>SET SHIFT INC ■ ■ □</p>	<p>Hold down the SHIFT key and press the SET key to switch to the flow rate data display.</p>

(3) Procedures for Changing Decimal Place

Before starting this procedure check in the data list if the position of the decimal point for the desired parameter decimal places can be changed.

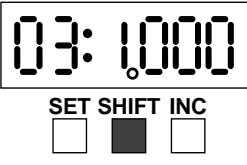
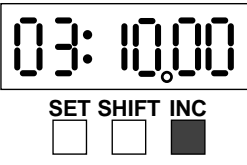
Example of parameter change : Changing the span from 1.000 to 10.00

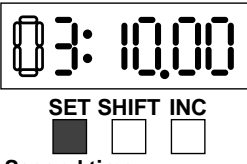
Item	Display	Content
① Selecting Decimal Position	 <p>SET SHIFT INC □ ■ □</p>	<p>Press the SHIFT key to move the flashing segment to the decimal point.</p>
② Moving Decimal Portion	 <p>SET SHIFT INC □ □ ■</p>	<p>Press the INC key to move the decimal point to the right.</p>
③ Data Entry	 <p>SET SHIFT INC ■ □ □ First time</p>  <p>SET SHIFT INC ■ □ □ Second time</p>	<p>Press the SET key twice to enter data. (All data will start flashing when the key is pressed the first time. Then wait 2 to 3 seconds before pressing the key the second time.)</p>

(4) Display of 5-digit Data

- The data display area has four digits and can therefore not display span and other 5-digit data parameters. To display such data, the data is automatically shifted (scrolled) to the left one digit at a time . When a 5-digit parameter is selected, the delimiter " : " starts to flash.
- When the flashing segment is aligned with the last digit and the data includes a space, the data is displayed as shown ④ on the right.

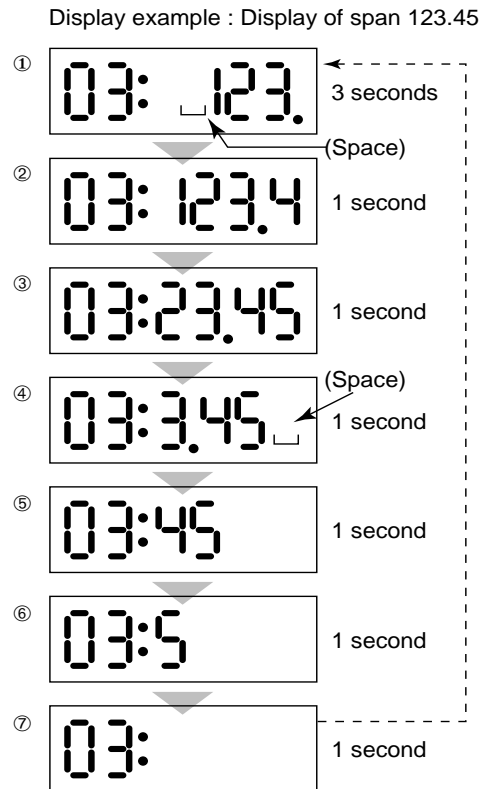

(5) Display of 6-digit Data

- The data display area has four digits and can therefore not display span and other 6-digit data parameters. (E05 TL SET VALUE is the only 6-digit parameter.) Like 5-digit data, 6-digit data is displayed by automatically shifting (scrolling) it to the left one digit at a time.

(6) Display and Setting Coded Data

- Example of change : Changing from +120 to -120

Item	Display	Content
1. Selecting Coded Data		The display on right indicates "+120".
2. Coded Data Flashes		Cause the "+" sign to flash.
3. Change of Coded Data		Press the INC key to change the "+" sign to a "-" sign. Press the SET key twice.

5.2.3 Alarm Display Mode

- When an alarm occurs, an alarm number indicating is displayed in place of the normal display mode.
However, this happens only when the current display mode is the flow rate data display mode or when parameter number are being changed in the setting mode. (Alarms are not displayed when data items are being changed.)

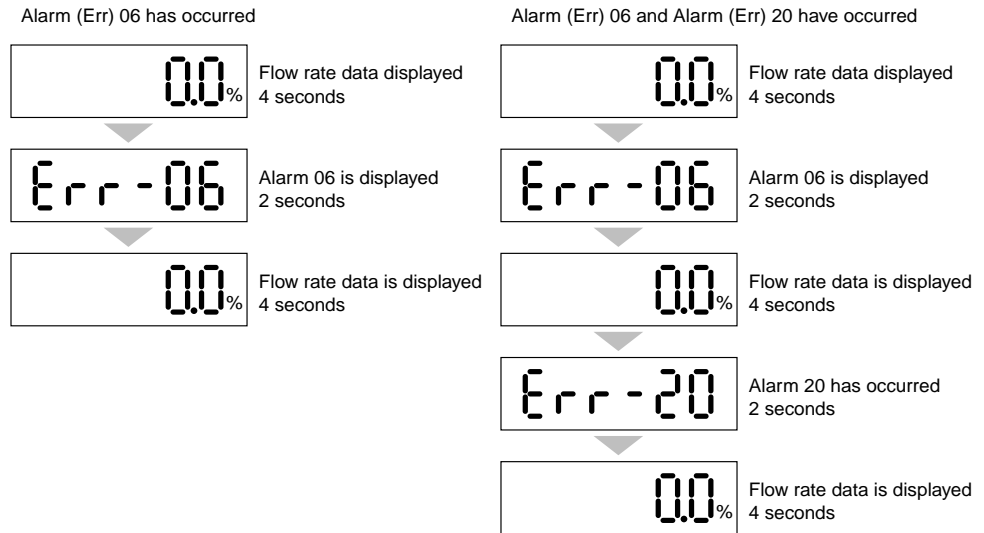

- See the section 8.2 Self-diagnostics function" for information on alarm numbers.

6. FUNCTION AND DATA SETTINGS

A Magnetic flowmeter calculates volume flow rate from a minute voltage that corresponds to the flow velocity of a fluid and outputs as a 4 to 20mA signal.



NOTE

The three parameters must be set to obtain a correct signal. Nominal size, flow span and meter factor must be set. In these three factors, Nominal size (unit:mm) and meter factor are set before shipment.

This chapter explains how to set flow span, other functions and data settings. Please set data correctly.



NOTE

You cannot set the leftmost digit of display to numeric value greater than "4". If the leftmost digit of the span must be "4" or more, set the numeric value beginning from the digit second from the left on the display (the fourth digit). If the leftmost digit of the display is set to "3", the digits to its right can be set to "0" only, regardless of the decimal point position.

Basic Key Operations

Item	Key Operation
How to change the display into the setting mode?	SET
How to move the cursor on the display during parameter setting?	SHIFT
How to change the display into the data changing mode?	SET
How to move the cursor in the data changing mode?	SHIFT
How to change the data?	INC
How to input the set data?	SET (Twice)

6.1 Setting Flow Span

(1) Determining the Flow Span

The flow rate span is the instantaneous flow rate value at which the output current is to be 20mA.

Please determine the span under considering the followings.

- Please set the maximum flow rate at the most variable flow rate line.
If the flow rate of the fluid exceeds the flow rate span value, the flow rate that exceeds this value (20mA or more) is not output and the flowmeter will not display the correct flow rate. (108% or more can't be output)
- In a line where the flow rate is comparatively stable, set a value that is 1.5 to 2.0 times larger than the normal flow rate.
- Please set a value that will correspond to a flow velocity of 0.3 to 10m/s.
Please confirm the flow velocity by sizing data or parameter No. "13".
(Parameter No. "13" indicates corresponding flow velocity to set span)
- The basic input value for display is flow span value. It is recommended that the accuracy of the first digit is in a 0.05 to 0.1% in case inputting the flow rate span value.
For example, 30m³/h should be set as 30.00m³/h.
- In a span setting, the maximum value that can set is "30000" except any relation with decimal position.

(2) Span Setting using Display Keys (Example setting: 30.00 m³/h)

• Span Value Setting

Switch Operation	Display	Description
<p>SET SHIFT INC</p> <p><input checked="" type="checkbox"/> <input type="checkbox"/> <input type="checkbox"/></p>		Press the SET key during flow rate data display mode to display setting mode shown in the left figure.
<p>SET SHIFT INC</p> <p><input type="checkbox"/> <input checked="" type="checkbox"/> <input type="checkbox"/></p>		Press the SHIFT key to cause the second digit from the left to flash.
<p>SET SHIFT INC</p> <p><input type="checkbox"/> <input type="checkbox"/> <input checked="" type="checkbox"/></p>		Press the INC key to call up parameter number 03. Default is set as 1.0000. Change this into 030.00.
<p>SET SHIFT INC</p> <p><input checked="" type="checkbox"/> <input type="checkbox"/> <input type="checkbox"/></p>		Press the SET key to move the flashing segment to the first digit in the data area.
<p>SET SHIFT INC</p> <p><input type="checkbox"/> <input type="checkbox"/> <input checked="" type="checkbox"/></p>		Press the INC key to set the first digit to 0.
<p>SET SHIFT INC</p> <p><input type="checkbox"/> <input checked="" type="checkbox"/> <input type="checkbox"/></p>		Press the SHIFT key to move the decimal point.
<p>SET SHIFT INC</p> <p><input type="checkbox"/> <input type="checkbox"/> <input checked="" type="checkbox"/></p>		Press the INC key to move the decimal point to "000.00". *To set a "00000." as the data area is a four digit LCD, the three digits and the space will be displayed as "000".
<p>SET SHIFT INC</p> <p><input type="checkbox"/> <input checked="" type="checkbox"/> <input type="checkbox"/></p>		Press the SHIFT key to move the flashing segment two digits to the right.
<p>SET SHIFT INC</p> <p><input type="checkbox"/> <input type="checkbox"/> <input checked="" type="checkbox"/></p>		Press the INC key to enter "3".
<p>SET SHIFT INC</p> <p><input checked="" type="checkbox"/> <input type="checkbox"/> <input type="checkbox"/></p>		Press the SET key once to cause all the data to flash. *As the data display now will be scrolled, it may not appear as shown in the left figure.
<p>SET SHIFT INC</p> <p><input checked="" type="checkbox"/> <input type="checkbox"/> <input type="checkbox"/></p>		Wait 2 to 3 seconds when the data starts flashing. Then press the SET key to return the flashing segment to the leftmost digit. *This display will also be scrolled to display 5-digit data.
	(Setting is now completed)	

Note : 5-digit span data can be displayed, but only digits will be supplied at one time. As a result, when the last digit is changed, the last digit and the space will be displayed as the last three digits. (See 5.2.2 "Display of 5-digit data".)

• Setting Volume Measurement (m³) and Time Unit (/h)

Switch Operation	Display	Description
(↓ Selecting m ³)		
SET SHIFT INC <input type="checkbox"/> <input checked="" type="checkbox"/> <input type="checkbox"/>	03:030.0	Press the SHIFT key to cause the second digit from the left to flash.
SET SHIFT INC <input type="checkbox"/> <input type="checkbox"/> <input checked="" type="checkbox"/>	04: 12	Press the INC key to call up parameter number 04.
SET SHIFT INC <input checked="" type="checkbox"/> <input type="checkbox"/> <input type="checkbox"/>	04: 12	Press the SET key to move the flashing segment to the data area.
SET SHIFT INC <input type="checkbox"/> <input type="checkbox"/> <input checked="" type="checkbox"/>	04: 01	Press the INC key to select "01" to display m ³ . (See the table on the right.)
SET SHIFT INC <input checked="" type="checkbox"/> <input type="checkbox"/> <input type="checkbox"/>	04: 01	Press the SET key once to cause all the data to flash.
SET SHIFT INC <input checked="" type="checkbox"/> <input type="checkbox"/> <input type="checkbox"/>	04: 01	Wait 2 to 3 seconds when the data starts flashing. Then press the SET key to return the flashing segment to the leftmost digit.
(↓ Selecting /h)		
SET SHIFT INC <input type="checkbox"/> <input checked="" type="checkbox"/> <input type="checkbox"/>	04: 01	Press the SHIFT key to cause the second digit from the left to flash.
SET SHIFT INC <input type="checkbox"/> <input type="checkbox"/> <input checked="" type="checkbox"/>	05: 03	Press the INC key to call up parameter number 05.
SET SHIFT INC <input checked="" type="checkbox"/> <input type="checkbox"/> <input type="checkbox"/>	05: 03	Press the SET key to move the flashing segment to the data area.
SET SHIFT INC <input type="checkbox"/> <input type="checkbox"/> <input checked="" type="checkbox"/>	05: 01	Press the INC key to select the code "01" to display /h. (See the table on the right.)
SET SHIFT INC <input checked="" type="checkbox"/> <input type="checkbox"/> <input type="checkbox"/>	05: 01	Press the SET key once to cause all the data to flash.
SET SHIFT INC <input checked="" type="checkbox"/> <input type="checkbox"/> <input type="checkbox"/>	05: 01	Wait 2 to 3 seconds when the data starts flashing. Then press the SET key to return the flashing segment to the leftmost digit.
(Setting is now completed.)		

Code	Volume Unit
00	km ³ (10 ³ × m ³)
01	m ³
02	L (liter)
03	cm ³ (10 ⁻² × m) ³
04	Mgal
05	kgal
06	gal
07	mgal
08	kbbbl
09	bbl
10	mbbl
11	μbbl
12	m
13	ft

Code	Time Unit
00	/d
01	/h
02	/m
03	/s

6.2 Power Frequency



IMPORTANT In case of DC power supply version, setting power frequency is required.

Display	Description
	Set the value in area where the frequency differs in parameter number "12". Setting Range : 47.00 to 53.00 Hz.

6.3 Other Functions and Settings

6.3.1 Pulse Output

(1) Pulse Output Overview

- By setting a pulse weight, a scaled pulse is transmitted to external counters and measuring instruments.

Pulse Output Overview

Item	Content
Output specifications	Transistor contact output (contact capacity is 30 V DC, 200 mA)
Connecting terminals	P+, P- When using these for pulse output, alarm output or status output are not available as the terminals are used commonly.
Pulse width	Selection: DUTY 50%, 0.5, 1, 20, 33, 50, 100 ms
Output rate	Min. 0.0001 P/s Max. 1000 P/s

* See page "4.4.6 Connecting external instruments" for information on how to connect external instruments.



NOTE

P+, P- terminals are for common use with pulse, alarm and other status output functions. Therefore, in case this function is used, other functions are not available to use.

(2) Procedures for Setting Pulse Output

Example setting : 10 liter output per pulse in a flow rate span of m³/h

Display	Description														
	Select "Pulse output" in parameter number "10". <table border="1" style="margin-top: 10px;"> <thead> <tr> <th>Code</th> <th>Content</th> </tr> </thead> <tbody> <tr> <td>00</td> <td>Pulse output</td> </tr> <tr> <td>01</td> <td>Alarm output</td> </tr> <tr> <td>02</td> <td>Forward/reverse flow measurement</td> </tr> <tr> <td>03</td> <td>Automatic two range switching</td> </tr> <tr> <td>04</td> <td>Alarm output at low flow limit</td> </tr> <tr> <td>05</td> <td>Totalization switch</td> </tr> </tbody> </table>	Code	Content	00	Pulse output	01	Alarm output	02	Forward/reverse flow measurement	03	Automatic two range switching	04	Alarm output at low flow limit	05	Totalization switch
Code	Content														
00	Pulse output														
01	Alarm output														
02	Forward/reverse flow measurement														
03	Automatic two range switching														
04	Alarm output at low flow limit														
05	Totalization switch														

Display	Description																																																
<div style="text-align: center; border: 1px solid black; padding: 5px; margin-bottom: 10px;"> F 1: 02 </div> <div style="text-align: center; margin-bottom: 10px;"> </div> <div style="text-align: center; border: 1px solid black; padding: 5px; margin-bottom: 10px;"> F2: 00 10 </div> <div style="text-align: center; margin-bottom: 10px;"> </div> <div style="text-align: center; border: 1px solid black; padding: 5px; margin-bottom: 10px;"> F3: 003 </div> <div style="text-align: center; margin-bottom: 10px;"> </div> <div style="text-align: center; border: 1px solid black; padding: 5px; margin-bottom: 10px;"> F4: 00 </div> <div style="text-align: center; margin-bottom: 10px;"> Default : 50%DUTY </div>	<p>Select the volume unit for pulse weight using parameter number "F1".</p> <table border="1" style="width: 100%; border-collapse: collapse; margin-bottom: 20px;"> <thead> <tr> <th style="width: 10%;">Code</th> <th>Volume Unit</th> </tr> </thead> <tbody> <tr> <td>00</td> <td>Volume unit in that for the flow rate span $\times 10^9$</td> </tr> <tr> <td>01</td> <td>Volume unit in that for the flow rate span $\times 10^6$</td> </tr> <tr> <td>02</td> <td>Volume unit in that for the flow rate span $\times 10^3$</td> </tr> <tr> <td>03</td> <td>Volume unit in that for the flow rate span $\times 1$</td> </tr> <tr> <td>04</td> <td>Volume unit in that for the flow rate span $\times 10^3$</td> </tr> <tr> <td>05</td> <td>Volume unit in that for the flow rate span $\times 10^6$</td> </tr> <tr> <td>06</td> <td>Number of pulses output per second at 100% of output</td> </tr> </tbody> </table> <p>Example : When pulses are to be output per same liter with the flow rate span of $\square\square \text{ m}^3/\text{h}$, select "02" since $\text{L}(\text{liter}) = 10^{-3} \times \text{m}^3$</p> <p>Set pulse weight "10 (L)" in parameter number "E2".</p> <p>※ Since parameter number "F2" is a 5-digit data item, scrolling is necessary to display all the data. Mind the decimal point when setting are made. (The decimal point can be moved if required.)</p> <p>Set the low cut range percentage in parameter "F3". Range of setting : 0 to 100% (of span)</p> <p>Select the pulse width in parameter number "F4".</p> <table border="1" style="width: 100%; border-collapse: collapse; margin-bottom: 20px;"> <thead> <tr> <th style="width: 10%;">Code</th> <th colspan="3">Pulse Width</th> </tr> </thead> <tbody> <tr> <td>00</td> <td>50%DUTY</td> <td>(Max. 1000P/s</td> <td>min. 0.0001P/s)</td> </tr> <tr> <td>01</td> <td>0.5ms</td> <td>(Max. 1000P/s</td> <td>min. 0.0001P/s)</td> </tr> <tr> <td>02</td> <td>1ms</td> <td>(Max. 500P/s</td> <td>min. 0.0001P/s)</td> </tr> <tr> <td>03</td> <td>20ms</td> <td>(Max. 25P/s</td> <td>min. 0.0001P/s)</td> </tr> <tr> <td>04</td> <td>33ms</td> <td>(Max. 15P/s</td> <td>min. 0.0001P/s)</td> </tr> <tr> <td>05</td> <td>50ms</td> <td>(Max. 10P/s</td> <td>min. 0.0001P/s)</td> </tr> <tr> <td>06</td> <td>100ms</td> <td>(Max. 5P/s</td> <td>min. 0.0001P/s)</td> </tr> </tbody> </table> <p style="border: 1px dashed black; padding: 5px; margin-bottom: 20px;">Normally, these are all required settings. The following settings are made depending on the applications that are used.</p>	Code	Volume Unit	00	Volume unit in that for the flow rate span $\times 10^9$	01	Volume unit in that for the flow rate span $\times 10^6$	02	Volume unit in that for the flow rate span $\times 10^3$	03	Volume unit in that for the flow rate span $\times 1$	04	Volume unit in that for the flow rate span $\times 10^3$	05	Volume unit in that for the flow rate span $\times 10^6$	06	Number of pulses output per second at 100% of output	Code	Pulse Width			00	50%DUTY	(Max. 1000P/s	min. 0.0001P/s)	01	0.5ms	(Max. 1000P/s	min. 0.0001P/s)	02	1ms	(Max. 500P/s	min. 0.0001P/s)	03	20ms	(Max. 25P/s	min. 0.0001P/s)	04	33ms	(Max. 15P/s	min. 0.0001P/s)	05	50ms	(Max. 10P/s	min. 0.0001P/s)	06	100ms	(Max. 5P/s	min. 0.0001P/s)
Code	Volume Unit																																																
00	Volume unit in that for the flow rate span $\times 10^9$																																																
01	Volume unit in that for the flow rate span $\times 10^6$																																																
02	Volume unit in that for the flow rate span $\times 10^3$																																																
03	Volume unit in that for the flow rate span $\times 1$																																																
04	Volume unit in that for the flow rate span $\times 10^3$																																																
05	Volume unit in that for the flow rate span $\times 10^6$																																																
06	Number of pulses output per second at 100% of output																																																
Code	Pulse Width																																																
00	50%DUTY	(Max. 1000P/s	min. 0.0001P/s)																																														
01	0.5ms	(Max. 1000P/s	min. 0.0001P/s)																																														
02	1ms	(Max. 500P/s	min. 0.0001P/s)																																														
03	20ms	(Max. 25P/s	min. 0.0001P/s)																																														
04	33ms	(Max. 15P/s	min. 0.0001P/s)																																														
05	50ms	(Max. 10P/s	min. 0.0001P/s)																																														
06	100ms	(Max. 5P/s	min. 0.0001P/s)																																														
<div style="text-align: center; border: 1px solid black; padding: 5px; margin-bottom: 10px;"> n 1: 01 </div> <div style="text-align: center; margin-bottom: 10px;"> Default : 01 (Damped flow rate value) </div> <div style="text-align: center; border: 1px solid black; padding: 5px; margin-bottom: 10px;"> n2: 00 </div> <div style="text-align: center;"> Default : 00(ON ACTIVE) </div>	<p>Select instantaneous flow rate or flow rate after damping for the pulse output . (The damping time is the value set in "B2").</p> <p>Set parameter "n2" to "01" when the pulse output transistor is to be off active.</p>																																																

*The "n" item can be opened by entering "55" in parameter number "L2".

6.3.2 Display of Internal Totalization Values

- The flow converter can display totalization values by setting the pulse weight.

(1) Setting Totalization Pulse Weight

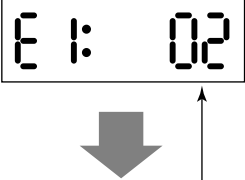
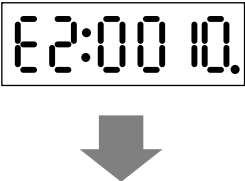
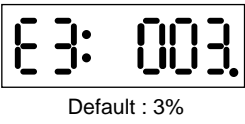
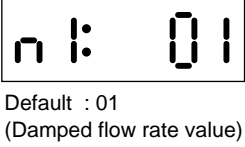

Example : Display 10 liter output per pulse in a flow rate span of $\square\square\square\text{ m}^3/\text{h}$

Display	Description																
	<p>Select the volume unit for pulse weight using parameter number "E1".</p> <table border="1"> <thead> <tr> <th>Code</th> <th>Volume Unit</th> </tr> </thead> <tbody> <tr> <td>00</td> <td>Volume unit in that for the flow rate span $\times 10^9$</td> </tr> <tr> <td>01</td> <td>Volume unit in that for the flow rate span $\times 10^6$</td> </tr> <tr> <td>02</td> <td>Volume unit in that for the flow rate span $\times 10^3$</td> </tr> <tr> <td>03</td> <td>Volume unit in that for the flow rate span $\times 1$</td> </tr> <tr> <td>04</td> <td>Volume unit in that for the flow rate span $\times 10^3$</td> </tr> <tr> <td>05</td> <td>Volume unit in that for the flow rate span $\times 10^6$</td> </tr> <tr> <td>06</td> <td>Number of pulses output per second at 100% of output</td> </tr> </tbody> </table> <p>Example : When pulses are to be output per same liter with the flow rate span of $\square\square\text{ m}^3/\text{h}$, select "02" since L (liter) = $10^{-3} \times \text{m}^3$</p>	Code	Volume Unit	00	Volume unit in that for the flow rate span $\times 10^9$	01	Volume unit in that for the flow rate span $\times 10^6$	02	Volume unit in that for the flow rate span $\times 10^3$	03	Volume unit in that for the flow rate span $\times 1$	04	Volume unit in that for the flow rate span $\times 10^3$	05	Volume unit in that for the flow rate span $\times 10^6$	06	Number of pulses output per second at 100% of output
Code	Volume Unit																
00	Volume unit in that for the flow rate span $\times 10^9$																
01	Volume unit in that for the flow rate span $\times 10^6$																
02	Volume unit in that for the flow rate span $\times 10^3$																
03	Volume unit in that for the flow rate span $\times 1$																
04	Volume unit in that for the flow rate span $\times 10^3$																
05	Volume unit in that for the flow rate span $\times 10^6$																
06	Number of pulses output per second at 100% of output																
	<p>Set pulse weight "10 (L)" in parameter number "E2".</p> <p>※ Since parameter number "E2" is a 5-digit data item, scrolling is necessary to display all the data. Mind the decimal point when setting are made. (The decimal point can be moved if required.)</p>																
	<p>Set the low cut range percentage in parameter "E3". Range of setting : 0 to 100% (of span)</p>																
	<p>Select pulse output calculation of instantaneous flow rate or flow rate after damping. (Use parameter "02" to set damping constant.)</p>																

*The "n" item can be opened by entering "55" in parameter number "L2".

6.3.3 Resetting for Totalization Display

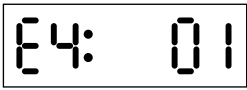
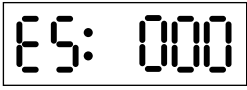
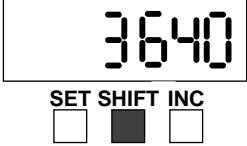
- This function is used to reset or preset totalization values of the display.
- Hold down the SHIFT key for more than 2 seconds while the totalization values of the flow rate are displayed to set the totalization value to the value set in parameter number "E5".

Display	Description						
 <p>Default : 00 (inhibit)</p> <p style="text-align: center;">↓</p>  <p>Default : 0</p> <p style="text-align: center;">↓</p>  <p style="text-align: center;">↓</p> 	<p>Select totalization enable in parameter number "E4"</p> <table border="1" style="margin-left: 40px;"> <thead> <tr> <th>Code</th> <th>Description</th> </tr> </thead> <tbody> <tr> <td>00</td> <td>Totalization preset inhibit</td> </tr> <tr> <td>01</td> <td>Totalization preset enable</td> </tr> </tbody> </table> <p>Set the totalization preset value in parameter number "E5". The initial value is 0, if it is no setting, the function is zero setting.</p> <p>Hold down the SHIFT key for more than 2 seconds while the totalization values of the flow rate reading are displayed to set the totalization value to the value set in parameter number "E5"</p>	Code	Description	00	Totalization preset inhibit	01	Totalization preset enable
Code	Description						
00	Totalization preset inhibit						
01	Totalization preset enable						

6.3.4 Damping Time Constant

- The time constant can be changed by setting the parameter No."02" to suppress a fluctuation or change a response time.
- The time constant influences to flow rate, pulse output and internal totalization. However, in case "00" is selected in parameter number "n1", the pulse output and internal totalization are not influenced by it.

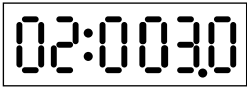
Display	Description
 <p>Default : 3 seconds</p>	<p>Set the value in parameter number "02". Setting Range : 0.1 to 200.0 seconds.</p>

6.3.5 Limiting Current Output During Alarm Occurrence

- The current output and display values during alarming can be selected in advance.

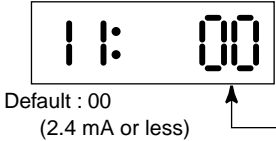
Display	Description										
 <p>Default : 00 (2.4 mA or less)</p>	<p>Set a value for current output to be used during alarms in parameter number "11"</p> <table border="1"> <thead> <tr> <th>Code</th> <th>Contents</th> </tr> </thead> <tbody> <tr> <td>00</td> <td>2.4mA or less</td> </tr> <tr> <td>01</td> <td>4.0mA</td> </tr> <tr> <td>02</td> <td>Hold</td> </tr> <tr> <td>03</td> <td>21.6mA or more</td> </tr> </tbody> </table>	Code	Contents	00	2.4mA or less	01	4.0mA	02	Hold	03	21.6mA or more
Code	Contents										
00	2.4mA or less										
01	4.0mA										
02	Hold										
03	21.6mA or more										

6.3.6 Reversing Flow Direction

- The flow direction is set to "FORWARD" at the factory. This function enables to set flow direction from "FORWARD" to "REVERSE".

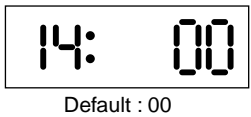
Display	Description						
 <p>Default : 00</p>	<p>The flow direction can be set in parameter No."14".</p> <table border="1"> <thead> <tr> <th>Code</th> <th>Contents</th> </tr> </thead> <tbody> <tr> <td>00</td> <td>Forward direction</td> </tr> <tr> <td>01</td> <td>Reverse direction to flow arrow</td> </tr> </tbody> </table>	Code	Contents	00	Forward direction	01	Reverse direction to flow arrow
Code	Contents						
00	Forward direction						
01	Reverse direction to flow arrow						

6.3.7 Limiting on Current Output

(1) 4 to 20 mA Low Cut Output (Current Output near by 0% Range)

- This function makes it possible to reduce fluctuations in the 0% region to reduce it to 0%.

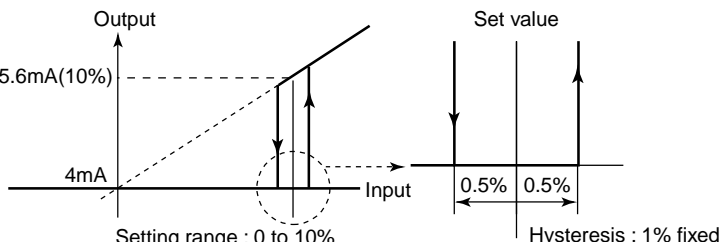
Display	Description
 <p>Default : 0(%)</p>	 <p>Setting range : 0 to 10% Hysteresis : 1% fixed</p>

(2) 4 to 20mA Low Limit

- This function limits the low end of the analog output.
- The default value is -20%, and -10% (2.4mA) as reverse flow limit. Please set in case other setting is required.
- 2.4mA or less output in alarming is also limited.

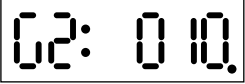
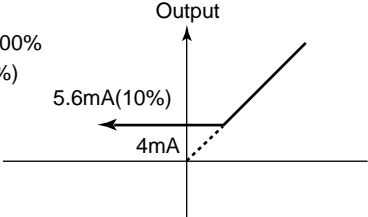
Display	Description
 <p>Default : -20(%)</p>	 <p>Setting Range : -20 to 100% Default : -20(%)</p>

(3) 4 to 20mA High Limit

- This function limits the high end of the analog output.
- The default value is 120% (23.2mA). Please set in case other setting is required.
- 21.6mA or more output in alarming is also limited.

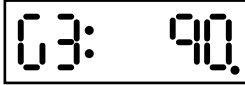
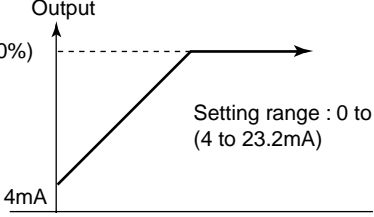
Display	Description
 <p>Default : 120(%)</p>	 <p>Setting range : 0 to 120% (4 to 23.2mA)</p>

6.3.8 Forward and Reverse Flow Measurement

- This function enables to measure forward and reverse flow rate without changing the flowmeter direction.
- By setting reverse range, in case fluids flow to reverse direction the flowmeter measures it as reverse direction range automatically. In this time, a status signal that shows changing into the reverse direction is output.
- To set the internal totalizing function for forward direction can also show it for reverse direction by parameter settings.
- P+, P- terminals are used for output connection.



NOTE

P+, P- terminals are for common use with pulse, alarm and other status output functions. Therefore, in case this function is used, other functions are not available to use.

Display	Description														
	<p>F and R flow rate measurement can be selected as "02" in parameter No. "10".</p> <table border="1"> <thead> <tr> <th>Code</th> <th>Content</th> </tr> </thead> <tbody> <tr> <td>00</td> <td>Pulse output</td> </tr> <tr> <td>01</td> <td>Alarm output</td> </tr> <tr> <td>02</td> <td>Forward / reverse flow measurement</td> </tr> <tr> <td>03</td> <td>Automatic two range switching</td> </tr> <tr> <td>04</td> <td>Alarm output at low flow limit</td> </tr> <tr> <td>05</td> <td>Totalization switch</td> </tr> </tbody> </table>	Code	Content	00	Pulse output	01	Alarm output	02	Forward / reverse flow measurement	03	Automatic two range switching	04	Alarm output at low flow limit	05	Totalization switch
Code	Content														
00	Pulse output														
01	Alarm output														
02	Forward / reverse flow measurement														
03	Automatic two range switching														
04	Alarm output at low flow limit														
05	Totalization switch														
	<p>Reverse direction span can be set in parameter No. "30". Flow rate unit is the same as forward direction span.</p>														
<p>(Default : 2%)</p>	<p>Futher reverse range span should be set in the same number of places of decimals as forward range span. Example: forward flow rate : 1.000 then revers flow rate should be 4.000.</p> <p>Hysteresis width at switching direction can be set in parameter No. "31". It is the rate (%) of the smaller span, either forward or reverse span.</p> <p style="text-align: right;">Status output Forward flow measurement: OFF Reverse flow measurement: ON</p> <p>When using reversed status (ON/OFF) is required, it can be set in "n2 Output Mode".</p>														



6.3.9 Automatic Two Range Switching

- When an input exceeds 100% of the first range, the range is automatically transferred to the second range and the status output changes state.
- P+, P- terminals are used for output connection.

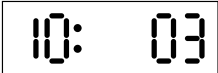

NOTE

P+, P- terminals are for common use with pulse, alarm and other status output functions. Therefore, in case this function is used, other functions are not available to use.

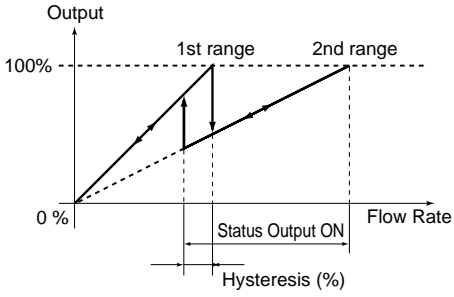
Display	Description														
 <p>Default : 00</p>	<p>Automatic two range transfer can be selected "03" in parameter No. "10".</p> <table border="1"> <thead> <tr> <th>Code</th> <th>Content</th> </tr> </thead> <tbody> <tr> <td>00</td> <td>Pulse output</td> </tr> <tr> <td>01</td> <td>Alarm output</td> </tr> <tr> <td>02</td> <td>Forward / reverse flow measurement</td> </tr> <tr> <td>03</td> <td>Automatic two range switching</td> </tr> <tr> <td>04</td> <td>Alarm output at low flow limit</td> </tr> <tr> <td>05</td> <td>Totalization switch</td> </tr> </tbody> </table>	Code	Content	00	Pulse output	01	Alarm output	02	Forward / reverse flow measurement	03	Automatic two range switching	04	Alarm output at low flow limit	05	Totalization switch
Code	Content														
00	Pulse output														
01	Alarm output														
02	Forward / reverse flow measurement														
03	Automatic two range switching														
04	Alarm output at low flow limit														
05	Totalization switch														
	<p>Forward second range can be set by calling up parameter No. "33". Setting restrictions: First range ≤ 2nd range.</p>														
 <p>Default : 10%</p>	<p>Further second range span should be set in the same number of places of decimals as first range span in parameter No. "03". Example: First range : 1.000 then second range should be 4.000</p> <p>Hysteresis width at switching range can be set in parameter No. "34". It is the rate (%) of first range span.</p>														
	 <p style="text-align: center;">Status Output 1st range: OFF 2nd range: ON</p>														
	<p>When using reversed status (ON/OFF) is required, it can be set in "n2 Output Mode".</p>														



6.3.10 Alarm Output at Low Flow Limit (Flow Switch)

- In case flow rate decrease under set level, an status signal is output.

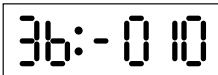

NOTE

P+, P- terminals are for common use with pulse, alarm and other status output functions. Therefore, in case this function is used, other functions are not available to use.

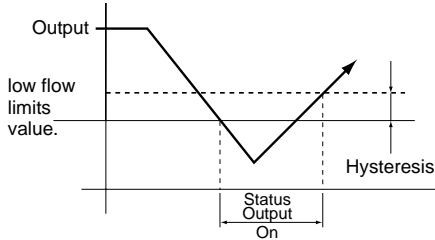
Display	Description														
 <p>Default : 00</p>	<p>Alarm output at low flow limits can be selected "04" in parameter No. "10".</p> <table border="1"> <thead> <tr> <th>Code</th> <th>Content</th> </tr> </thead> <tbody> <tr> <td>00</td> <td>Pulse output</td> </tr> <tr> <td>01</td> <td>Alarm output</td> </tr> <tr> <td>02</td> <td>Forward / reverse flow measurement</td> </tr> <tr> <td>03</td> <td>Automatic two range switching</td> </tr> <tr> <td>04</td> <td>Alarm output at low flow limit</td> </tr> <tr> <td>05</td> <td>Totalization switch</td> </tr> </tbody> </table>	Code	Content	00	Pulse output	01	Alarm output	02	Forward / reverse flow measurement	03	Automatic two range switching	04	Alarm output at low flow limit	05	Totalization switch
Code	Content														
00	Pulse output														
01	Alarm output														
02	Forward / reverse flow measurement														
03	Automatic two range switching														
04	Alarm output at low flow limit														
05	Totalization switch														
 <p>(Default : -10%)</p>	<p>The Low Limit value can be set in parameter No. "36" as percentage for 4 to 20 mA.</p>														
 <p>(Default : 5%)</p>	<p>Hysteresis width is set in parameter No. "37".</p> 														
	<p>When using reversed status (ON/OFF) is required, it can be set in "n2 Output Mode".</p>														



6.3.11 Totalization Switch Output

- In case the Internal Totalization Value increase over set level, an alarm signal is output.

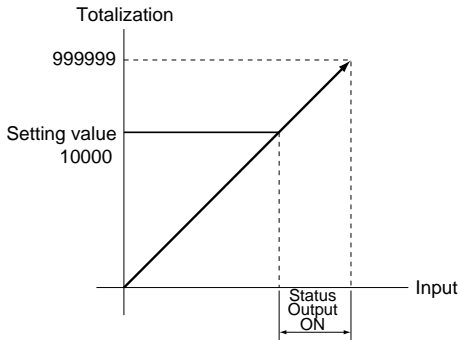

NOTE

P+, P- terminals are for common use with pulse, alarm and other status output functions. Therefore, in case this function is used, other functions are not available to use.

Display	Description														
 <p>Default : 00</p>	<p>Totalization switch can be selected as "05" in parameter No. "10".</p> <table border="1"> <thead> <tr> <th>Code</th> <th>Content</th> </tr> </thead> <tbody> <tr> <td>00</td> <td>Pulse output</td> </tr> <tr> <td>01</td> <td>Alarm output</td> </tr> <tr> <td>02</td> <td>Forward / reverse flow measurement</td> </tr> <tr> <td>03</td> <td>Automatic two range switching</td> </tr> <tr> <td>04</td> <td>Alarm output at low flow limit</td> </tr> <tr> <td>05</td> <td>Totalization switch</td> </tr> </tbody> </table> <p>Switch level can be selected by calling up parameter No. "06".</p>  <p>When using reversed status (ON/OFF) is required, it can be set in "n2 Output Mode".</p>	Code	Content	00	Pulse output	01	Alarm output	02	Forward / reverse flow measurement	03	Automatic two range switching	04	Alarm output at low flow limit	05	Totalization switch
Code		Content													
00	Pulse output														
01	Alarm output														
02	Forward / reverse flow measurement														
03	Automatic two range switching														
04	Alarm output at low flow limit														
05	Totalization switch														
 <p>Default : 0</p>															

6.3.12 Alarm Output

- This function is for status output from PLS/ALM+, PLS/ALM- terminals, when an alarm occurs.

	NOTE	P+, P- terminals are for common use with pulse, alarm and other status output functions. Therefore, in case this function is used, other functions are not available to use.
---	-------------	---

- All of the alarms are able to output except empty pipe detection function that can be selected in parameter No. "n7" as out of selection.
- The status goes from close to open (OFF) during alarming.

Display	Description														
<div style="border: 1px solid black; padding: 5px; display: inline-block;"> 10: 01 </div> Default : 00	The alarm output can be selected "01" in parameter No. "10" and P+, P- terminals are only for alarm output. <table border="1" style="margin-top: 10px;"> <thead> <tr> <th>Code</th> <th>Content</th> </tr> </thead> <tbody> <tr><td>00</td><td>Pulse output</td></tr> <tr><td>01</td><td>Alarm output</td></tr> <tr><td>02</td><td>Forward / reverse flow measurement</td></tr> <tr><td>03</td><td>Automatic two range switching</td></tr> <tr><td>04</td><td>Alarm output at low flow limit</td></tr> <tr><td>05</td><td>Totalization switch</td></tr> </tbody> </table>	Code	Content	00	Pulse output	01	Alarm output	02	Forward / reverse flow measurement	03	Automatic two range switching	04	Alarm output at low flow limit	05	Totalization switch
Code	Content														
00	Pulse output														
01	Alarm output														
02	Forward / reverse flow measurement														
03	Automatic two range switching														
04	Alarm output at low flow limit														
05	Totalization switch														
<div style="border: 1px solid black; padding: 5px; display: inline-block;"> n7: 01 </div> Default : 00	The empty pipe output selection can be set in parameter No. "n7". <table border="1" style="margin-top: 10px;"> <thead> <tr> <th>Code</th> <th>Content</th> </tr> </thead> <tbody> <tr><td>00</td><td>ALARM</td></tr> <tr><td>01</td><td>NO ALARM</td></tr> </tbody> </table>	Code	Content	00	ALARM	01	NO ALARM								
Code	Content														
00	ALARM														
01	NO ALARM														

* Item "N" can be opened by entering "55" in parameter number "L2".

6.3.13 Data Setting Enable / Inhibit

- This function can inhibit to change all data except parameter No. "L1". However, auto zero adjustment function can work, if it has been set in parameter No. "C1". And the preset totalization value function also can work, if it has been set in parameter No. "E4".

Display	Description						
<div style="border: 1px solid black; padding: 5px; display: inline-block;"> L1: 00 </div> Default : 01	The data setting inhibit item can be set "00" in parameter number "L1". <table border="1" style="margin-top: 10px;"> <thead> <tr> <th>Code</th> <th>Content</th> </tr> </thead> <tbody> <tr><td>00</td><td>INHIBIT</td></tr> <tr><td>01</td><td>ENABLE</td></tr> </tbody> </table>	Code	Content	00	INHIBIT	01	ENABLE
Code	Content						
00	INHIBIT						
01	ENABLE						

6.3.14 Procedure of Selecting Special Application Items

- Only the special application (“n” items) shipped being unpublished.
In case the “n” items should be used, it can be set “55” in parameter No. “L2”.

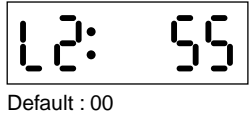
Display	Description						
	<p>It is possible to open up to item n when "55" is entered in parameter number "L2".</p> <table border="1"> <thead> <tr> <th>Code</th> <th>Content</th> </tr> </thead> <tbody> <tr> <td>00</td> <td>Accessible up to L parameters</td> </tr> <tr> <td>01</td> <td>Accessible up to n parameters</td> </tr> </tbody> </table>	Code	Content	00	Accessible up to L parameters	01	Accessible up to n parameters
Code	Content						
00	Accessible up to L parameters						
01	Accessible up to n parameters						

6.3.15 Rate Limit

- This function is used to remove noise that cannot be removed by increasing the damping time constant.
- In case unexpected noise from step signal or slurry is entered, a basis is set to recognize that signal is flow rate or noise.
The recognition depends on rate limit value (upper and lower limit) and dead time (sampling time).
- Determination of rate limit value and dead time.

Rate limit value:
Determine the level to reduce output fluctuation.
For example, reducing 2% or more fluctuation by setting as 2% to reduce.

Dead time T_0 :
Please determine the dead time depending on output fluctuation width.
In case of noise of which is longer than the dead time, please set the dead time longer.

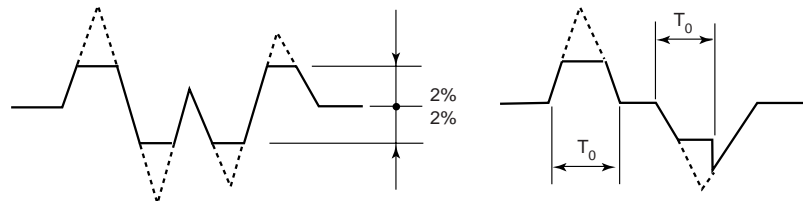

- **Signal processing procedures:**
The function sets a certain upper and lower limit (rate limit value) for first order delay response values of flow rate data obtained in a previous sampling. If currently sampled flow rate data exceeds or goes below the limit is regarded as current flow rate value. Signals whose protruding portions show the same trends during a certain number of sampling times (dead time) are identified as flow rate signals.

Example 1: Step Input

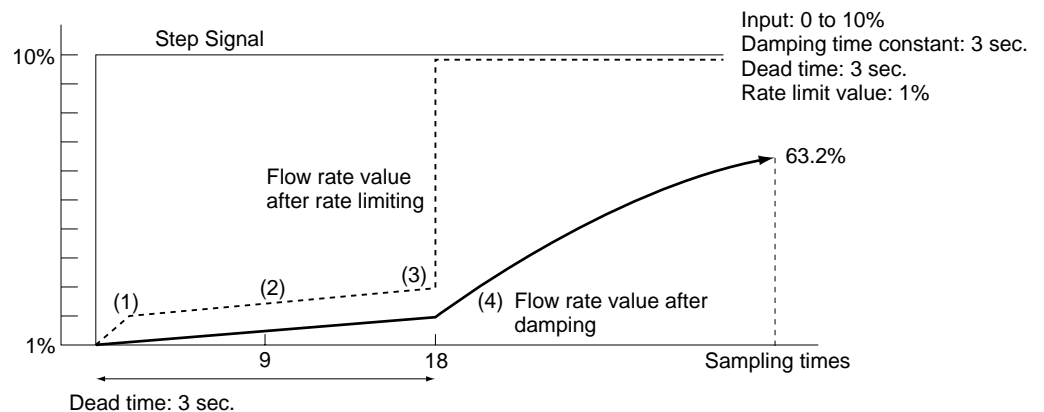

- (1) Shows 1% response cause of excessive signal beyond the rate limit. However, actual output is under damping that described by a solid line.
- (2) Shows the flow rate signal (1%) of just after damping calculation (1) and rate limit value.
- (3) This signal is recognized as a flow rate signal since it does not return to within the rate limit value within the dead time.
- (4) The output signal follows the damping curve and tracks the step signal.

Example 2: Slurry Noise

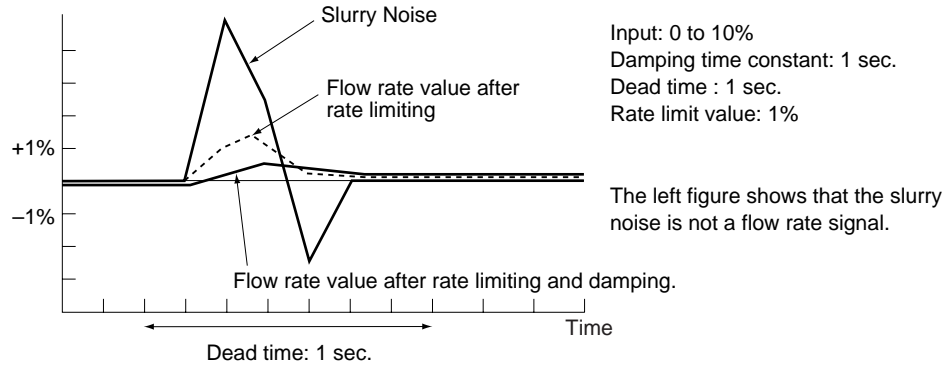

Display	Description
	Set a rate limit value in parameter number "n3". Setting Range : 0 to 10%.
	Set the dead time in parameter number "n4". Setting Range : 0 to 15 seconds.

*Item "n" can be opened by entering "55" in parameter number "L2".

6.3.16 Pulsating Flow

- The pulsating flow produced by a plunger pump results in inaccurate average flow rate values. This function makes it possible to accurately track flow rate changes and control calculation.

Display	Description						
	Select "01" (pulsating flow counteraction) in parameter number "n6". <table border="1" style="margin-top: 10px;"> <thead> <tr> <th>Code</th> <th>Contents</th> </tr> </thead> <tbody> <tr> <td>00</td> <td>Nomal</td> </tr> <tr> <td>01</td> <td>Counteracting pulsating flow</td> </tr> </tbody> </table>	Code	Contents	00	Nomal	01	Counteracting pulsating flow
Code	Contents						
00	Nomal						
01	Counteracting pulsating flow						

*Item "n" can be opened by entering "55" in parameter number "L2".

7. OPERATION VIA BRAIN TERMINAL

Products with optional code / BR (BRAIN communication function) come equipped with a BRAIN communication function which allows them to communicate with dedicated BRAIN terminals (BT) or CENTUM systems. In the BRAIN series communications system, a ± 2 mA, 2.4 kHz modulated signal is superimposed onto the 4 to 20 mA DC analog signal for data transmission. Since the modulated wave is an AC signal superimposed on the analog signal will cause no error in the DC component of the analog signal. Thus, monitoring can be performed via communications while the ADMAG AE is online.

A BRAIN terminal can be connected to the terminals shown in Figure 7.1 on products that are not provided with / BR (BRAIN communication function).

7.1 Operation Via the BT200

This section describes the operation procedures using a BRAIN terminal. For details on the functions of the ADMAG AE, see Chapter 6, "Function and Data Settings." And also, see the "BT200 Instruction Manual" (IM 1COA11-01E) for more detailed information.

7.1.1 BT200 Connections

(1) Connecting BT200 to Converter

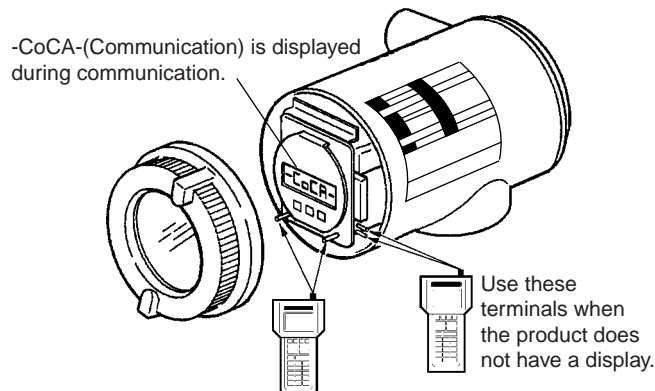

Figure 7.1 Connection of BRAIN terminal to Converter

For products not provided with / BR (BRAIN communication function), the terminals for BRAIN communication are provided on the circuit board. Please connect BT200 to the terminals on the circuit board directly.

(2) Connecting the BT200 to a 4 to 20 mA DC Transfer Line

The communication signal of the ADMAG AE with / BR is superimposed onto the 4 to 20 mA DC analog signal to be transferred.

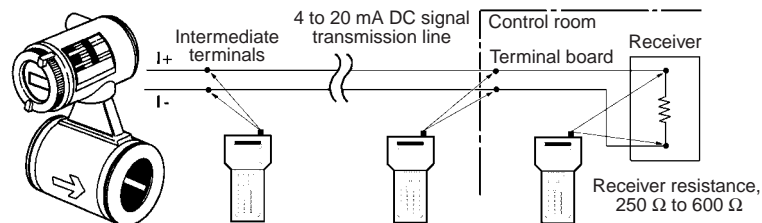
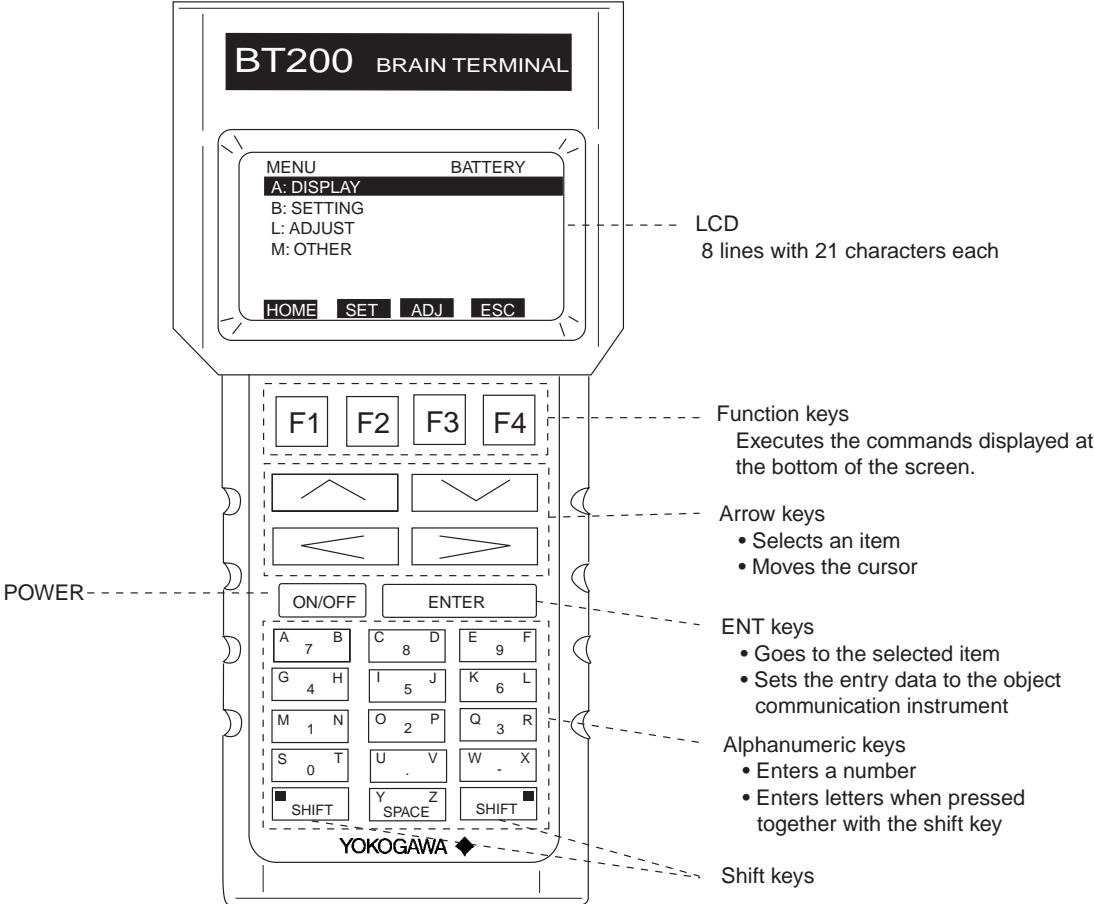

Figure 7.2 Communicating via a 4 to 20 mA DC Signal Line

7.1.2 BT200 Keypad Layout

Figure 7.3 shows the key pad lay out of the BT200.



Menu panel
Major parameters items
A maximum of six items are displayed.

Parameter panel
Parameter data
A maximum of three items are displayed.

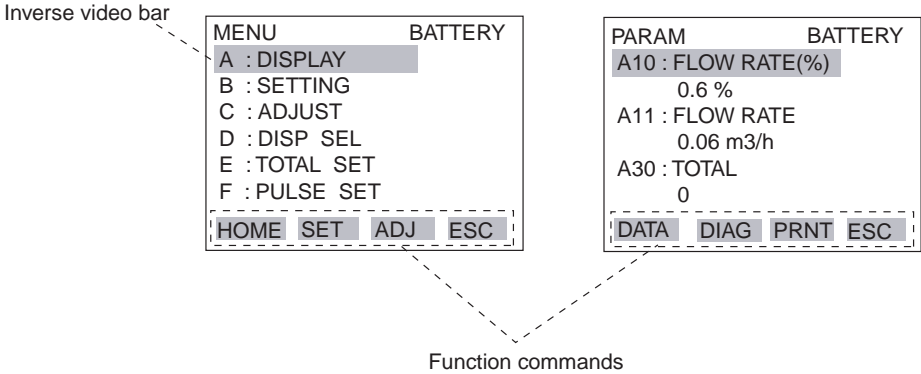

Figure 7.3 Key Layout and Functions

7.1.3 Major BT200 Key Functions

(1) Entry of Alphanumeric Characters

Numbers, codes and letters can be entered in combinations of the alphanumeric keys and the SHIFT key.

- **Entry of numbers, codes and a space (0 to 9, ., -, _)**
 Entering of them is possible by using the alphanumeric keys.

Example of entry	Key Operation
-4.3	
1 _ -0.3	

- **Entry of letters**
 Press an alphanumeric key while one of the SHIFT keys is pressed and the letter on the same side of the key as the shift key that is pressed can be entered. Press the SHIFT key each time when entering a letter.

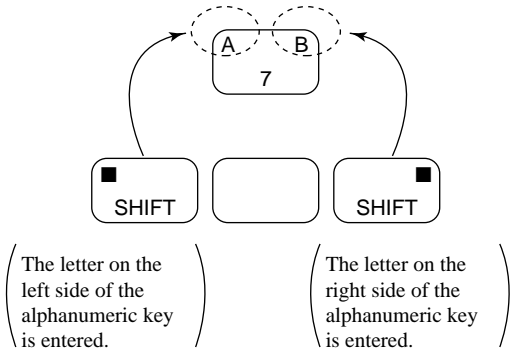

Example of entry	Key operation
WIC	
J.B	

- **Selection of uppercase / lowercase of letters**
 Uppercase and lowercase letters can be selected alternately by pressing the function key [F2] (CAPS).

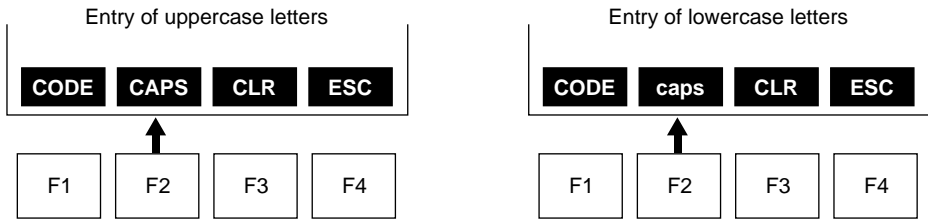

• **Entry of codes**

Codes can be entered by pressing the function key [F1] (CODE). Every time [F1] CODE is pressed, the codes are displayed at the cursor position in the order shown below.

/ . - , + *) (' & % \$ # " !

To enter characters after the codes above, move the cursor using the [>] key before entry.

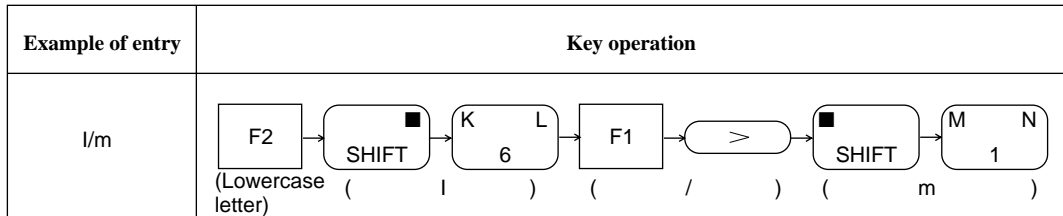

(2) Function Keys

The functions of the function keys vary with the commands being displayed on the display panel.

MENU

A:DISPLAY

B:SET

C:ADJUST

D:DISP SEL

E:TOTAL SET

F:PULSE SET

HOME SET ADJ ESC

F1 F2 F3 F4

Function keys

Command	Description
ADJ	Calls up the zero-adjustment menu.
CAPS/caps	Changes the uppercase / lowercase mode.
C LR	Clears entered data / deletes all data.
CODE	See the above "Entry of codes."
COPY*	Prints parameters on the screen.
DATA	Updates parameter data.
DEL	Deletes one character.
DIAG	Calls up the self-check screen.
ESC	Returns to the preceding screen.
FEED*	Paper feed.
HOME	Calls up the home menu (A : DISPLAY).
LIST*	Prints all parameters of the menus.
NO	Setting stop / re-setting. Returns to the previous screen
OK	Goes to the next screen.
PARM	Parameter number setting mode.
PON/POFF*	Printer output of data whose setting was changed Mode on / off
PRNT*	Changes to the prints mode.
SET	Calls up the setting menu. (B : SETTING)
SLOT	Returns to the slot selection screen.
GO*	Starts print out.
STOP*	Stops printing.
UTIL	Transfers to the utility screen.

* The command is available only for BT200-P00.

7.1.4 Displaying Flow Rate Data

Flow rate data can be displayed on the BT200 screen according to the following procedure.

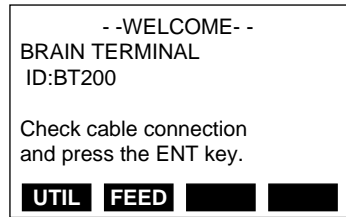

Turn the power on and the screen on the left appears after "please wait..." is displayed for a few seconds.

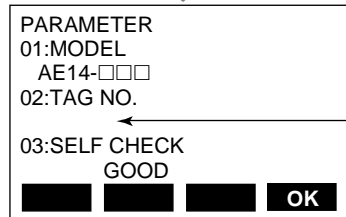

Pressing the ENTER key causes the initial data screen on the left to be displayed.

The tag number specified upon ordering is entered.

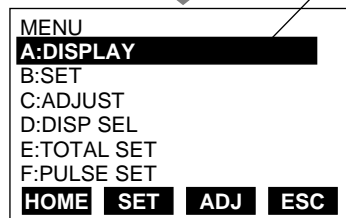

Inverse video bar

Pressing the F4 key or the ENTER key causes the menu screen on the left to be displayed.

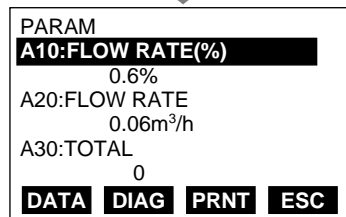

- With "A : DISPLAY" displayed on the menu panel in the inverse video bar, press the ENTER key and the flow data screen appears.
- A maximum of three data items can be displayed on one screen.
- Data are communicated at an interval of 5 seconds. Thus, the data are updated every 5 seconds.
- The arrow keys, [^], [v] or [<], [>], are used for page feeds or item selection.

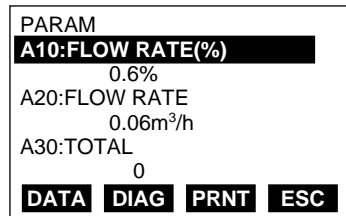

Execution of the function keys

- F1:** Updates the current data. Pressing this key causes forcible communication with the connected instruments and the data of the instruments are loaded to be read.
- F2:** Displays the self-check screen.
- F3:** Displays the parameter print screen.
- F4:** Returns to the previous panel (menu panel).

7.2 Setting Parameters



NOTE

The three parameter must be set to obtain a correct signal.
 Nominal size, flow span and meter factor must be set.
 In these three factors, Nominal size(unit: mm) and meter factor are set before shipment.

7.2.1 Setting Flow Span

Example: Flow span 10.0 m³/h

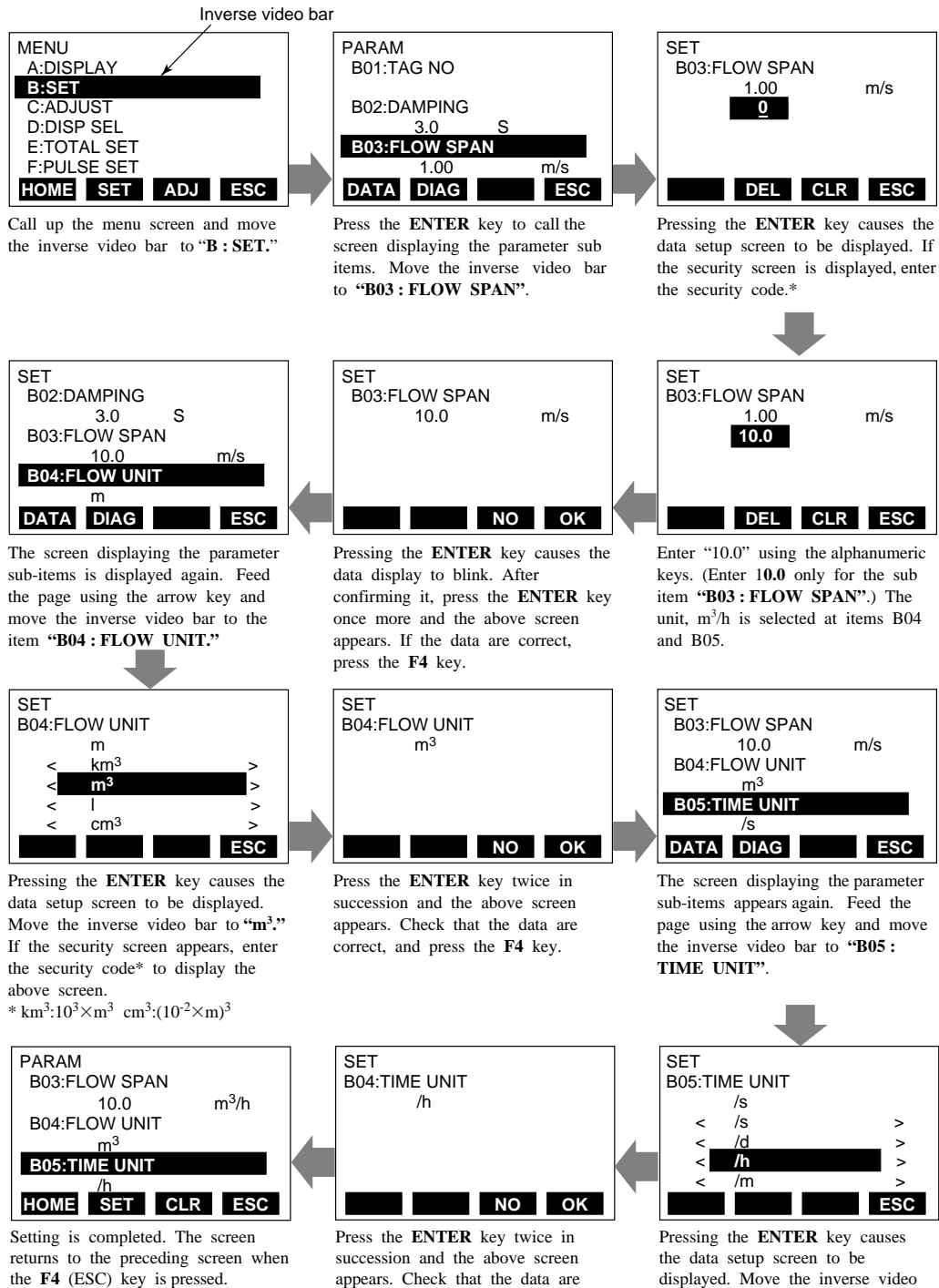

*For entry of the security code, see IM 1C0A11-01E.

7.2.2 Power Frequency

IMPORTANT In case of DC power supply version, setting power frequency is required.

Display	Description
<pre> PARAM B10:OUTPUT FUNC PULSE OUT B11:4-20ALM OUT 2.4mA OR LESS B12:POWER FREQ 50.03Hz DATA DIAG ESC </pre>	<p>Set value in areas where the frequency differs in "B12 : POWER FREQ". Default:50.00Hz. Setting Range : 47.00 to 53.00Hz</p>

7.2.3 Pulse Output (Refer to 6.3.1)

Example setting : 10 L output per pulse in a flow rate span of $\square\square\square\text{ m}^3/\text{h}$

Display	Description																														
<pre> PARAM B10:OUTPUT FUNC PULSE OUT B11:4-20ALM OUT 2.4mA OR LESS B12:POWER FREQ 50.03Hz DATA DIAG ESC </pre>	<p>The pulse output terminals (P+, P-) are also used for alarms. Select "Pulse output" in parameter number "B10".</p> <table border="1" style="width: 100%; border-collapse: collapse;"> <thead> <tr> <th>Code</th> <th>Content</th> </tr> </thead> <tbody> <tr><td>PULSE OUT</td><td>Pulse output</td></tr> <tr><td>ALARM OUT</td><td>Alarm output</td></tr> <tr><td>BI DIRECTION</td><td>Forward / reverse flow measurement</td></tr> <tr><td>AUTO 2 RANGES</td><td>Automatic two range switching</td></tr> <tr><td>LOW ALARM</td><td>Alarm output at low flow limits</td></tr> <tr><td>TOTAL SWTICH</td><td>Totalization switch</td></tr> </tbody> </table> <p>Select the volume unit for the pulse weight in parameter number "B04".</p> <table border="1" style="width: 100%; border-collapse: collapse;"> <thead> <tr> <th>Code</th> <th>Volume unit</th> </tr> </thead> <tbody> <tr><td>n UNIT/P</td><td>Volume unit in that for the flow rate span $\times 10^9$</td></tr> <tr><td>m UNIT/P</td><td>Volume unit in that for the flow rate span $\times 10^6$</td></tr> <tr><td>m UNIT/P</td><td>Volume unit in that for the flow rate span $\times 10^3$</td></tr> <tr><td>UNIT/P</td><td>Volume unit in that for the flow rate span $\times 1$</td></tr> <tr><td>k UNIT/P</td><td>Volume unit in that for the flow rate span $\times 10^3$</td></tr> <tr><td>M UNIT/P</td><td>Volume unit in that for the flow rate span $\times 10^6$</td></tr> <tr><td>P ULSE/s</td><td>Number of pulses output per second at 100% of output</td></tr> </tbody> </table> <p>Example) When pulses are to be output per same liter with the flow rate span of $\square\square\square\text{ m}^3/\text{h}$, select "m UNIT/P" since a L(liter) = $10^{-3} \times \text{m}^3$ Set the pulse weight "10 (L)" in parameter number "F02".</p> <p>*Since parameter number "F02" is a 5-digit data item, scrolling is necessary to display all the data. Mind the decimal point when setting are made. (The decimal point can be moved if required.)</p>	Code	Content	PULSE OUT	Pulse output	ALARM OUT	Alarm output	BI DIRECTION	Forward / reverse flow measurement	AUTO 2 RANGES	Automatic two range switching	LOW ALARM	Alarm output at low flow limits	TOTAL SWTICH	Totalization switch	Code	Volume unit	n UNIT/P	Volume unit in that for the flow rate span $\times 10^9$	m UNIT/P	Volume unit in that for the flow rate span $\times 10^6$	m UNIT/P	Volume unit in that for the flow rate span $\times 10^3$	UNIT/P	Volume unit in that for the flow rate span $\times 1$	k UNIT/P	Volume unit in that for the flow rate span $\times 10^3$	M UNIT/P	Volume unit in that for the flow rate span $\times 10^6$	P ULSE/s	Number of pulses output per second at 100% of output
Code	Content																														
PULSE OUT	Pulse output																														
ALARM OUT	Alarm output																														
BI DIRECTION	Forward / reverse flow measurement																														
AUTO 2 RANGES	Automatic two range switching																														
LOW ALARM	Alarm output at low flow limits																														
TOTAL SWTICH	Totalization switch																														
Code	Volume unit																														
n UNIT/P	Volume unit in that for the flow rate span $\times 10^9$																														
m UNIT/P	Volume unit in that for the flow rate span $\times 10^6$																														
m UNIT/P	Volume unit in that for the flow rate span $\times 10^3$																														
UNIT/P	Volume unit in that for the flow rate span $\times 1$																														
k UNIT/P	Volume unit in that for the flow rate span $\times 10^3$																														
M UNIT/P	Volume unit in that for the flow rate span $\times 10^6$																														
P ULSE/s	Number of pulses output per second at 100% of output																														
<pre> PARAM F01:PULSE UNIT m UNIT/P F02:PULSE SCALE 10 m UNIT/P F03:PULSE LOWCUT 3. % DATA DIAG ESC </pre>	<p>Set the low cut range percentage in parameter "F03". Range of setting : (0 to 100% of span)</p>																														
<pre> PARAM F02:PULSE UNIT 10 m UNIT/P F03:PULSE LOWCUT 3. % F04:PULSE WIDTH 50% DUTY DATA DIAG ESC </pre>	<p>Select the pulse width in parameter number "F04"</p> <table border="1" style="width: 100%; border-collapse: collapse;"> <thead> <tr> <th>Code</th> <th>Pulse width</th> </tr> </thead> <tbody> <tr><td>50%DUTY</td><td>(Max. of 1000P/s Min. 0.0001P/s)</td></tr> <tr><td>0.5ms</td><td>(Max. of 1000P/s Min. 0.0001P/s)</td></tr> <tr><td>1ms</td><td>(Max. of 500P/s Min. 0.0001P/s)</td></tr> <tr><td>20ms</td><td>(Max. of 25P/s Min. 0.0001P/s)</td></tr> <tr><td>33ms</td><td>(Max. of 15P/s Min. 0.0001P/s)</td></tr> <tr><td>50ms</td><td>(Max. of 10P/s Min. 0.0001P/s)</td></tr> <tr><td>100ms</td><td>(Max. of 5P/s Min. 0.0001P/s)</td></tr> </tbody> </table>	Code	Pulse width	50%DUTY	(Max. of 1000P/s Min. 0.0001P/s)	0.5ms	(Max. of 1000P/s Min. 0.0001P/s)	1ms	(Max. of 500P/s Min. 0.0001P/s)	20ms	(Max. of 25P/s Min. 0.0001P/s)	33ms	(Max. of 15P/s Min. 0.0001P/s)	50ms	(Max. of 10P/s Min. 0.0001P/s)	100ms	(Max. of 5P/s Min. 0.0001P/s)														
Code	Pulse width																														
50%DUTY	(Max. of 1000P/s Min. 0.0001P/s)																														
0.5ms	(Max. of 1000P/s Min. 0.0001P/s)																														
1ms	(Max. of 500P/s Min. 0.0001P/s)																														
20ms	(Max. of 25P/s Min. 0.0001P/s)																														
33ms	(Max. of 15P/s Min. 0.0001P/s)																														
50ms	(Max. of 10P/s Min. 0.0001P/s)																														
100ms	(Max. of 5P/s Min. 0.0001P/s)																														
<p>Normally, these are all required settings. The following settings are made depending on the application that is used.</p>																															
<pre> PARAM N01:TOTAL/PULSE DAMP N02:OUTPUT MODE ON N03:RATE LIMIT 5. % DATA DIAG ESC </pre>	<p>Select instantaneous flow rate or flow rate after damping data for the pulse output. (The damping time value is the value set in "02"). Default : DAMP</p> <p>Set parameter "02" to "OFF" when the pulse output transistor is to be off-active.</p>																														

* The "N" item can be opened by entering "55" in parameter number "L02".

7.2.4 Display of Internal Totalization Values (Refer to 6.3.2)

Example : 10 L output per pulse in a flow rate span of $\square\square\square\text{ m}^3/\text{h}$

Display	Description																
<pre>PARAM E01:TOTAL UNIT m UNIT/P ← E02:TOTAL SCALE 10 m UNIT/P ← E03:TOTAL LOWCUT 3. % ← [DATA] [DIAG] [] [ESC]</pre>	<p>Select the volume unit for the pulse weight in parameter number "E01."</p> <table border="1"> <thead> <tr> <th>Code</th> <th>Volume unit</th> </tr> </thead> <tbody> <tr> <td>n UNIT/P</td> <td>Volume unit used in that for the flow rate span $\times 10^{-9}$</td> </tr> <tr> <td>μ UNIT/P</td> <td>Volume unit used in that for the flow rate span $\times 10^{-6}$</td> </tr> <tr> <td>m UNIT/P</td> <td>Volume unit used in that for the flow rate span $\times 10^{-3}$</td> </tr> <tr> <td>UNIT/P</td> <td>Volume unit used in that for the flow rate span $\times 1$</td> </tr> <tr> <td>k UNIT/P</td> <td>Volume unit used in that for the flow rate span $\times 10^3$</td> </tr> <tr> <td>M UNIT/P</td> <td>Volume unit used in that for the flow rate span $\times 10^6$</td> </tr> <tr> <td>PULSE/s</td> <td>Number of pulse output per second at 100% of output</td> </tr> </tbody> </table> <p>Example) When pulses are to be output per same liter with the flow rate span of $\square\square\text{m}^3/\text{h}$, select "m UNIT/P" since a L(liter) = $10^{-3} \times \text{m}^3$</p>	Code	Volume unit	n UNIT/P	Volume unit used in that for the flow rate span $\times 10^{-9}$	μ UNIT/P	Volume unit used in that for the flow rate span $\times 10^{-6}$	m UNIT/P	Volume unit used in that for the flow rate span $\times 10^{-3}$	UNIT/P	Volume unit used in that for the flow rate span $\times 1$	k UNIT/P	Volume unit used in that for the flow rate span $\times 10^3$	M UNIT/P	Volume unit used in that for the flow rate span $\times 10^6$	PULSE/s	Number of pulse output per second at 100% of output
Code	Volume unit																
n UNIT/P	Volume unit used in that for the flow rate span $\times 10^{-9}$																
μ UNIT/P	Volume unit used in that for the flow rate span $\times 10^{-6}$																
m UNIT/P	Volume unit used in that for the flow rate span $\times 10^{-3}$																
UNIT/P	Volume unit used in that for the flow rate span $\times 1$																
k UNIT/P	Volume unit used in that for the flow rate span $\times 10^3$																
M UNIT/P	Volume unit used in that for the flow rate span $\times 10^6$																
PULSE/s	Number of pulse output per second at 100% of output																
<pre>PARAM N01:TOTAL/PULSE DAMP ← N02:OUTPUT MODE ON N03:RATE LIMIT 5. % [DATA] [DIAG] [] [ESC]</pre>	<p>Set the pulse weight "10 (L)" in parameter number "E02."</p> <p>Set the low cut range percentage in parameter "E03." Range of setting : (0 to 100% of span)</p>																
<pre>PARAM A10:FLOW RATE(%) 50.0 % A20:FLOW RATE 50.0 m³/h A30:TOTAL 12345 [DATA] [DIAG] [PRNT] [ESC]</pre> <p style="text-align: center;">↓</p> <pre>SETTING A30:TOTAL 0 [] [] [CLR] [ESC]</pre> <p style="text-align: center;">ENTER</p>	<p>Select instantaneous flow rate or flow rate after damping for the pulse output. (The damping time value is the value set in "B02.") Default : DAMP (damped flow rate data)</p>																

* The "N" item can be opened by entering "55" in parameter number "L02".

7.2.5 Resetting for Totalization Display (Refer to 6.3.3)

Display	Description						
<pre>PARAM E04:TOTAL SET ENABLE ← E05:TL SET VALUE 0 ← E10:TOTAL SWITCH 0 [DATA] [DIAG] [] [ESC]</pre>	<p>Select totalization enable in parameter number "E04."</p> <table border="1"> <thead> <tr> <th>Code</th> <th>Description</th> </tr> </thead> <tbody> <tr> <td>ENABLE</td> <td>Totalization presetting enabled</td> </tr> <tr> <td>INHIBIT</td> <td>Totalization presetting disabled</td> </tr> </tbody> </table>	Code	Description	ENABLE	Totalization presetting enabled	INHIBIT	Totalization presetting disabled
Code	Description						
ENABLE	Totalization presetting enabled						
INHIBIT	Totalization presetting disabled						
<pre>PARAM A10:FLOW RATE(%) 50.0 % A20:FLOW RATE 50.0 m³/h A30:TOTAL 12345 [DATA] [DIAG] [PRNT] [ESC]</pre> <p style="text-align: center;">↓</p> <pre>SETTING A30:TOTAL 0 [] [] [CLR] [ESC]</pre> <p style="text-align: center;">ENTER</p>	<p>Set the totalization preset value in parameter number "E05." The default is 0 and if the setting is omitted, the parameter functions reset to 0.</p> <p>If the ENT key is pressed twice while "A30:TOTAL" is displayed on the setting screen, the totalization value (A30:TOTAL) will be replaced with the values set in "E05."</p>						

7.2.6 Damping Time Constant (Refer to 6.3.4)

Display	Description
<pre> PARAM B01:TAG NO B02:DAMPING 3.0 s B03:FLOW SPAN 1.00 m/s DATA DIAG ESC </pre>	<p>Set the value in parameter number "B02." Setting Range : 0.1 to 200.0 seconds.</p>

7.2.7 Current Output during Alarm Occurrence (Refer to 6.3.5)

Display	Description										
<pre> PARAM B10:OUTPUT FUNC PULSE OUT B11:4-20 ALM OUT 2.4mA OR LESS B12:POWER FREQ 50.03Hz DATA DIAG ESC </pre>	<p>Set the value for current output to be used during alarms in parameter "B11." (Default : 2.4 mA or less)</p> <table border="1"> <thead> <tr> <th>Code</th> <th>Content</th> </tr> </thead> <tbody> <tr> <td>2.4mA OR LESS</td> <td>2.4 mA or less</td> </tr> <tr> <td>4.0mA</td> <td>4.0 mA</td> </tr> <tr> <td>HOLD</td> <td>Fixed to output when alarm is generated.</td> </tr> <tr> <td>21.6mA OR MORE</td> <td>21.6 mA or more</td> </tr> </tbody> </table>	Code	Content	2.4mA OR LESS	2.4 mA or less	4.0mA	4.0 mA	HOLD	Fixed to output when alarm is generated.	21.6mA OR MORE	21.6 mA or more
Code	Content										
2.4mA OR LESS	2.4 mA or less										
4.0mA	4.0 mA										
HOLD	Fixed to output when alarm is generated.										
21.6mA OR MORE	21.6 mA or more										

7.2.8 Reversing Flow Direction (Refer to 6.3.6)

Display	Description						
<pre> PARAM B13:VELOCITY CHK 5 m/s B14:FLOW DIR REVERSE B60:SELF CHECK GOOD m/s DATA DIAG ESC </pre>	<p>The flow direction can be set in parameter number "B14"</p> <table border="1"> <thead> <tr> <th>Code</th> <th>Description</th> </tr> </thead> <tbody> <tr> <td>FORWARD</td> <td>Forward direction</td> </tr> <tr> <td>REVERSE</td> <td>Reverse direction to flow arrow</td> </tr> </tbody> </table>	Code	Description	FORWARD	Forward direction	REVERSE	Reverse direction to flow arrow
Code	Description						
FORWARD	Forward direction						
REVERSE	Reverse direction to flow arrow						

7.2.9 Limiting Current Output (Refer to 6.3.7)

(1) 4 to 20 mA low cut output (Current Output near by 0% Range)

Display	Description
<pre> PARAM G01:4-20 LOW CUT 10 % G02:4-20 LOW LMT -20 % G03:4-20 H LMT 110 % DATA DIAG ESC </pre>	<p>Setting range : 0 to 10% Default:0% Hysteresis:1% fixed</p>

(2) 4 to 20 mA Low Limit

Display	Description
<pre> PARAM G01:4-20 LOW CUT 0 % G02:4-20 LOW LMT 10 % ← G03:4-20 H LMT 110 % DATA DIAG ESC </pre>	<p>Setting Range : -20 to 100% Default : -20%</p>

(3) 4 to 20 mA High Limit

Display	Description
<pre> PARAM G01:4-20 LOW CUT 0 % G02:4-20 LOW LMT -20 % G03:4-20 H LMT 90 % ← DATA DIAG ESC </pre>	<p>Setting range : 0 to 120% Default : 120%</p>

7.2.10 Forward and Reverse Flow Measurement (Refer to 6.3.8)

Display	Description														
<pre> PARAM B09:HIGH MF 1.0000 B10:OUTPUT FUNC BI DIRECTION ← B11:4-20 ALM OUT 2.4mA OR LESS DATA DIAG ESC </pre>	<p>Select "BI DIRECTION" (Direct / reverse flow measuring mode) in parameter number "B10".</p> <table border="1"> <thead> <tr> <th>Code</th> <th>Content</th> </tr> </thead> <tbody> <tr> <td>PULSE OUT</td> <td>Pulse output</td> </tr> <tr> <td>ALARM OUT</td> <td>Alarm output</td> </tr> <tr> <td>BI DIRECTION</td> <td>Forward / reverse flow measurement</td> </tr> <tr> <td>AUTO 2 RANGES</td> <td>Automatic two range switching</td> </tr> <tr> <td>LOW ALARM</td> <td>Alarm output at low flow limits</td> </tr> <tr> <td>TOTAL SWTICH</td> <td>Totalization switch</td> </tr> </tbody> </table>	Code	Content	PULSE OUT	Pulse output	ALARM OUT	Alarm output	BI DIRECTION	Forward / reverse flow measurement	AUTO 2 RANGES	Automatic two range switching	LOW ALARM	Alarm output at low flow limits	TOTAL SWTICH	Totalization switch
Code	Content														
PULSE OUT	Pulse output														
ALARM OUT	Alarm output														
BI DIRECTION	Forward / reverse flow measurement														
AUTO 2 RANGES	Automatic two range switching														
LOW ALARM	Alarm output at low flow limits														
TOTAL SWTICH	Totalization switch														
<pre> PARAM B30 :REV. SPAN □□□ ← B31 :BI. DIREC HYS □□ ← B33 :FOR. SPAN2 □□□ ← DATA DIAG ESC </pre>	<p>Reverse direction span can be set in parameter No."B30". Flow rate unit is the same as forward direction span.</p> <p>Further reverse range span should be set in the same number of places of decimals as forward range span. Example: forward flow rate : 1.000 then reverse flow rate should be 4.000.</p> <p>Hysteresis width at switching direction can be set in parameter No."B31". It is the rate(%) of the smaller span, either forward or reverse span.</p>														

7.2.11 Automatic Two Range Switching (Refer to 6.3.9)

Display	Description														
<pre> PARAM B09:HIGH MF 1.0000 B10:OUTPUT FUNC AUTO 2 RANGES ← B11:4-20 ALM OUT 2.4mA OR LESS DATA DIAG ESC </pre>	<p>Select "AUTO 2 RANGES" (Automatic two range transfer) in parameter number "B10".</p> <table border="1"> <thead> <tr> <th>Code</th> <th>Content</th> </tr> </thead> <tbody> <tr> <td>PULSE OUT</td> <td>Pulse output</td> </tr> <tr> <td>ALARM OUT</td> <td>Alarm output</td> </tr> <tr> <td>BI DIRECTION</td> <td>Forward / reverse flow measurement</td> </tr> <tr> <td>AUTO 2 RANGES</td> <td>Automatic two range switching</td> </tr> <tr> <td>LOW ALARM</td> <td>Alarm output at low flow limits</td> </tr> <tr> <td>TOTAL SWTICH</td> <td>Totalization switch</td> </tr> </tbody> </table>	Code	Content	PULSE OUT	Pulse output	ALARM OUT	Alarm output	BI DIRECTION	Forward / reverse flow measurement	AUTO 2 RANGES	Automatic two range switching	LOW ALARM	Alarm output at low flow limits	TOTAL SWTICH	Totalization switch
Code		Content													
PULSE OUT	Pulse output														
ALARM OUT	Alarm output														
BI DIRECTION	Forward / reverse flow measurement														
AUTO 2 RANGES	Automatic two range switching														
LOW ALARM	Alarm output at low flow limits														
TOTAL SWTICH	Totalization switch														
<pre> PARAM B31:BI DIREC HYS <input type="checkbox"/> <input type="checkbox"/> B33:FOR. SPAN2 <input type="checkbox"/> <input type="checkbox"/> ← B34:AUTO RNG HYS <input type="checkbox"/> ← DATA DIAG ESC </pre>	<p>Forward second range can be set by calling up parameter No. B33. Setting restrictions: First range ≤ 2nd range.</p> <p>Further second range span should be set in the same number of places of decimals as first range span in parameter No. B03. Example: First range : 1.000 then second range should be 4.000</p> <p>Hysteresis width at switching range can be set in parameter No. B34. It is the rate (%) of first range span.</p>														

7.2.12 Alarm Output at Low Flow Limits (Flow Switch) (Refer to 6.3.10)

Display	Description														
<pre> PARAM B09:HIGH MF 1.0000 B10:OUTPUT FUNC LOW ALARM ← B11:4-20 ALM OUT 2.4mA OR LESS DATA DIAG ESC </pre>	<p>Select "LOW ALARM" (Alarm output at low flow limits) in parameter number "B10".</p> <table border="1"> <thead> <tr> <th>Code</th> <th>Content</th> </tr> </thead> <tbody> <tr> <td>PULSE OUT</td> <td>Pulse output</td> </tr> <tr> <td>ALARM OUT</td> <td>Alarm output</td> </tr> <tr> <td>BI DIRECTION</td> <td>Direct / reverse flow measurement</td> </tr> <tr> <td>AUTO 2 RANGES</td> <td>Automatic two range transfer</td> </tr> <tr> <td>LOW ALARM</td> <td>Alarm output at low flow limits</td> </tr> <tr> <td>TOTAL SWTICH</td> <td>Totalization switch</td> </tr> </tbody> </table>	Code	Content	PULSE OUT	Pulse output	ALARM OUT	Alarm output	BI DIRECTION	Direct / reverse flow measurement	AUTO 2 RANGES	Automatic two range transfer	LOW ALARM	Alarm output at low flow limits	TOTAL SWTICH	Totalization switch
Code		Content													
PULSE OUT	Pulse output														
ALARM OUT	Alarm output														
BI DIRECTION	Direct / reverse flow measurement														
AUTO 2 RANGES	Automatic two range transfer														
LOW ALARM	Alarm output at low flow limits														
TOTAL SWTICH	Totalization switch														
<pre> PARAM B34:AUTO RNG HYS <input type="checkbox"/> <input type="checkbox"/> B36:LOW ALARM <input type="checkbox"/> ← B37:L. ALARM HYS <input type="checkbox"/> ← DATA DIAG ESC </pre>	<p>Set the comparison level in parameter number "B36".</p> <p>Set the hysteresis in parameter "B37".</p>														

7.2.13 Totalization Switch Output (Refer to 6.3.11)

Display	Description														
<pre> PARAM B09:HIGH MF 1.0000 B10:OUTPUT FUNC TOTAL SWITCH ← B11:4-20 ALM OUT 2.4mA OR LESS DATA DIAG ESC </pre>	<p>Select "TOTAL SWITCH" (Totalization Switch) in parameter number "B10"</p> <table border="1" style="width:100%; border-collapse: collapse; margin-top: 10px;"> <thead> <tr> <th style="width:30%;">Code</th> <th>Content</th> </tr> </thead> <tbody> <tr><td>PULSE OUT</td><td>Pulse output</td></tr> <tr><td>ALARM OUT</td><td>Alarm output</td></tr> <tr><td>BI DIRECTION</td><td>Forward / reverse flow measurement</td></tr> <tr><td>AUTO 2 RANGES</td><td>Automatic two range switching</td></tr> <tr><td>LOW ALARM</td><td>Alarm output at low flow limits</td></tr> <tr><td>TOTAL SWTICH</td><td>Totalization switch</td></tr> </tbody> </table>	Code	Content	PULSE OUT	Pulse output	ALARM OUT	Alarm output	BI DIRECTION	Forward / reverse flow measurement	AUTO 2 RANGES	Automatic two range switching	LOW ALARM	Alarm output at low flow limits	TOTAL SWTICH	Totalization switch
Code	Content														
PULSE OUT	Pulse output														
ALARM OUT	Alarm output														
BI DIRECTION	Forward / reverse flow measurement														
AUTO 2 RANGES	Automatic two range switching														
LOW ALARM	Alarm output at low flow limits														
TOTAL SWTICH	Totalization switch														
<pre> PARAM E05:TL SET VALUE □□□ E06:TOTAL SWITCH □□□□ ← E10:TL USER UNIT □□ DATA DIAG ESC </pre>	<p>Set the switch level in parameter number "E6".</p>														

7.2.14 Alarm Output (Refer to 6.3.12)

Display	Description														
<pre> PARAM B10:OUTPUT FUNC ALARM OUT ← B11:4-20 ALM OUT 2.4mA OR LESS B12:POWER FREQ 50.03Hz DATA DIAG ESC </pre>	<p>Set "ALARM" in parameter number "B10" to use the P+ and P- terminals for alarm output only.</p> <table border="1" style="width:100%; border-collapse: collapse; margin-top: 10px;"> <thead> <tr> <th style="width:30%;">Code</th> <th>Content</th> </tr> </thead> <tbody> <tr><td>PULSE OUT</td><td>Pulse output</td></tr> <tr><td>ALARM OUT</td><td>Alarm output</td></tr> <tr><td>BI DIRECTION</td><td>Forward / reverse flow measurement</td></tr> <tr><td>AUTO 2 RANGES</td><td>Automatic two range switching</td></tr> <tr><td>LOW ALARM</td><td>Alarm output at low flow limits</td></tr> <tr><td>TOTAL SWTICH</td><td>Totalization switch</td></tr> </tbody> </table>	Code	Content	PULSE OUT	Pulse output	ALARM OUT	Alarm output	BI DIRECTION	Forward / reverse flow measurement	AUTO 2 RANGES	Automatic two range switching	LOW ALARM	Alarm output at low flow limits	TOTAL SWTICH	Totalization switch
Code	Content														
PULSE OUT	Pulse output														
ALARM OUT	Alarm output														
BI DIRECTION	Forward / reverse flow measurement														
AUTO 2 RANGES	Automatic two range switching														
LOW ALARM	Alarm output at low flow limits														
TOTAL SWTICH	Totalization switch														
<pre> PARAM N06:PULSING FLOW NO N07:EMPTY PIPE ALARM ← N60:SELF CHECK GOOD DATA DIAG ESC </pre>	<p>Select whether an empty pipe alarm is to be performed or not in parameter number "N07."</p> <table border="1" style="width:100%; border-collapse: collapse; margin-top: 10px;"> <thead> <tr> <th style="width:30%;">Code</th> <th>Content</th> </tr> </thead> <tbody> <tr><td>ALARM</td><td>ALARM</td></tr> <tr><td>NO ALARM</td><td>NO ALARM</td></tr> </tbody> </table>	Code	Content	ALARM	ALARM	NO ALARM	NO ALARM								
Code	Content														
ALARM	ALARM														
NO ALARM	NO ALARM														

* The "N" item can be opened by entering "55" in parameter number "L02".

7.2.15 Data Setting Enable / Inhibit (Refer to 6.3.13)

- This function makes it possible to inhibit all data changes (except L1). However, automatic zero adjustment can be made if the automatic zero-adjustment function is enabled (set in C1). Also, totalization presetting can be done if the totalization presetting function is enabled (set in E4).

Display	Description						
<pre> PARAM L01:TUNING INHIBIT ← L02:KEY 00 L60:SELF CHECK GOOD DATA DIAG ESC </pre>	<p>Selecting "INHIBIT" in parameter number "L01" disables data setting.</p> <table border="1"> <thead> <tr> <th>Code</th> <th>Content</th> </tr> </thead> <tbody> <tr> <td>ENABLE</td> <td>Data setting enabled.</td> </tr> <tr> <td>INHIBIT</td> <td>Data setting disabled.</td> </tr> </tbody> </table> <p>← Default</p>	Code	Content	ENABLE	Data setting enabled.	INHIBIT	Data setting disabled.
Code	Content						
ENABLE	Data setting enabled.						
INHIBIT	Data setting disabled.						

7.2.16 Procedure of Selecting Special Application Items (Refer to 6.3.14)

Displayed	Description						
<pre> PARAM L01:TUNING INHIBIT L02:KEY 55 ← L60:SELF CHECK GOOD DATA DIAG ESC </pre>	<p>It is possible to open up to item N when "55" is entered in parameter number "L02."</p> <table border="1"> <thead> <tr> <th>Code</th> <th>Content</th> </tr> </thead> <tbody> <tr> <td>00</td> <td>Accessible up to L parameters</td> </tr> <tr> <td>55</td> <td>Accessible up to N parameters</td> </tr> </tbody> </table> <p>← Default</p>	Code	Content	00	Accessible up to L parameters	55	Accessible up to N parameters
Code	Content						
00	Accessible up to L parameters						
55	Accessible up to N parameters						

7.2.17 Rate Limit (Refer to 6.3.15)

Display	Description
<pre> PARAM N03:RATE LIMIT 5 % ← N04:DEAD TIME 0 s ← N05:POWER SYNCH YES DATA DIAG ESC </pre>	<p>Set the rate limit value in parameter number "N03." Range of possible settings : 0 to 10%.</p> <p>Set the dead time in parameter number "N04." Range of possible settings : 0 to 15 seconds. Default : 0 (Rate limit function off)</p>

* The "N" item can be opened by entering "55" in parameter number "L02".

7.2.18 Pulsating Flow (Refer to 6.3.16)

Display	Description						
<pre> PARAM N04:DEAD TIME 0 N05:POWER SYNCH YES N06:PULSING FLOW YES ← DATA DIAG ESC </pre>	<p>Select "YES" (pulsating flow counteraction) in parameter number "N06" (Default : NO)</p> <table border="1"> <thead> <tr> <th>Code</th> <th>Content</th> </tr> </thead> <tbody> <tr> <td>NO</td> <td>Normal</td> </tr> <tr> <td>YES</td> <td>Counteracting pulsating flow</td> </tr> </tbody> </table>	Code	Content	NO	Normal	YES	Counteracting pulsating flow
Code	Content						
NO	Normal						
YES	Counteracting pulsating flow						

* The "N" item can be opened by entering "55" in parameter number "L02".

7.2.19 User-Defined Units Via the BT200

This function displays the instantaneous flow rate indicated in "A20 FLOW RATE" in units other than those selectable with B04. If the specific gravity of the fluid is known, the instantaneous flow rate can be displayed in weight units.

(1) User-Defined Units for Instantaneous Flow Rate

Example : Displaying the flow rate of a fluid (its specific gravity is 2) in weight (kg) in a flow rate span of 10m³/h. When the flow rate is 100%, 20,000kg is displayed.

Display	Description
<pre> PARAM D02:FL USER SEL PROVIDED ← D03:FL USER SPAN 20000.0 ← D10:FL USER UNIT kg/h ← DATA DIAG [] ESC </pre>	<p>Select "PROVIDED" in "D02."</p> <p>For item "D03," set the value to be displayed in "A20 FLOW RATE" when the flow rate is 100% in the span set in "B03FLOW SPAN." Set the unit in "D10".</p> <p>Set the user-defined unit in "D10."</p>
	
<pre> PARAM A10:FLOW RATE(%) 100.0% A20:FLOW RATE 20000.0 kg/h ← A30:TOTAL 12345 DATA DIAG [] ESC </pre>	<p>The instantaneous flow rate in user-defined unit can be displayed in "A20 : FLOWRATE."</p>

(2) User-Defined Units for Totalization Values

User-defined unit can be added to the totalization display in "A30 TOTAL".

Display	Description
<pre> PARAM E04:TOTAL SET INHIBIT E05:TL SET VALUE 0 E10:TL USER UNIT [][] ← DATA DIAG [] ESC </pre>	<p>Set the user-defined unit in the item "E10."</p>
	
<pre> PARAM A10:FLOW RATE(%) 100.0% A20:FLOW RATE 40000.0 kg/h A30:TOTAL 12345 [][] ← DATA [] CLR ESC </pre>	<p>The totalization value in user-defined unit can be displayed in "A30 TOTAL" .</p>

7.2.20 Other Important Points to Note

- (1) The automatic power-off function turns the terminal off automatically if no key is pressed for about 5 minutes or more. However, this function does not operate when the terminal is displaying the variables in (2) below.
- (2) When A10 FLOW RATE (%) or A20 FLOW RATE is displayed, data are updated every 5 seconds.
- (3) UPLD is used when the parameters of one ADMAG AE are copied to the BT and DNLD is used when the parameters copied to the BT are copied to another ADMAG AE. (For details, see the "BT200 Instruction Manual " (IM 1C0A11-01E). Parameters that can be copied include span and pulse factor parameters such as the following:

B02 DAMPING, B03 FLOW SPAN, B04 FLOW UNIT, B05 TIME UNIT
B06 SIZE UNIT, B07 NOMINAL SIZE, B10 OUTPUT FUNC, B11 4-20 ALM OUT
D01 DISP SELECT, D02 FL USER SEL, D03 FL USER SPAN, D10 FL
USERUNIT, E01 TOTAL UNIT, E02 TOTAL SCALE, E03 TOTAL LOWCUT,
E04 TOTAL SET, E05 TL SET VALUE, E10 TL USER UNIT, F01 PULSE
SELECT, F02 PULSE SCALE, F03 PULSE LOW CUT, F04 PULSE WIDTH,
G01 4-20 LOW CUT, G02 4-20 LOW LMT, G03 4-20 H LMT.

8. ACTUAL OPERATION

After you have installed the flowtube into the process piping, wired the input / output terminals, set up the required parameters, and performed the pre-operation zero adjustment, the magnetic flowmeter should output an accurate flow signal from its terminals as soon as the measured liquid begins to flow.

This section describes procedures of zero adjustment and alarms countermeasure.

8.1 Pre-Operation Zero Adjustment

In the magnetic flowmeter, zero adjustment is required before beginning operation in order to obtain a 4 to 20mA signal that is accurately proportional to the flow.

This section describes two procedures for performing zero adjust : one using the switches on the converter panel and the other using the BT200. Use either method.

Zero adjustment is made to set the instrument to 0% (4mA) when the flow rate is 0.

The flow tube must be filled with fluid and let it stand until all motion has ceased.



IMPORTANT

- Zero adjustment should be done only when the fluid is filled in the flow tube and the fluid velocity is completely zero by closing the valve.
- Zero adjustment should be done prior to the other operation. For 30 seconds during the zero adjustment, any setting cannot be accepted.

8.1.1 Zero Adjustment Using Data Setting Keys

The following two procedures can be used to perform zero adjustment with the data setting keys.

(1) Hold Down the INC Key for Two Seconds in Flow Rate Data Display Mode.

Display	Description						
	<p>Call up the setting mode and set "01" in "C1". (zero adjustment enable / inhibit)</p> <table border="1"> <thead> <tr> <th>Code</th> <th>Content</th> </tr> </thead> <tbody> <tr> <td>00</td> <td>INHIBIT</td> </tr> <tr> <td>01</td> <td>ENABLE</td> </tr> </tbody> </table> <p>Hold down the INC key for two seconds in flow rate data display mode.</p> <p>The display panel shows "-ZEro-". After about 30 seconds, the zero correction is displayed. Then the meter returns to data display mode.</p>	Code	Content	00	INHIBIT	01	ENABLE
Code	Content						
00	INHIBIT						
01	ENABLE						

(2) Display "C2" and Press the SET key Twice.

Display	Description						
	<p>Call up the setting mode and set "01" in "C1" (zero adjustment enable/inhibit).</p> <table border="1"> <thead> <tr> <th>Code</th> <th>Content</th> </tr> </thead> <tbody> <tr> <td>00</td> <td>INHIBIT</td> </tr> <tr> <td>01</td> <td>ENABLE</td> </tr> </tbody> </table> <p>Call up "C2" and press the SET key twice (as for data entry).</p> <p>The display panel shows "-ZEro-". After about 32 seconds, the zero correction is displayed. Then the meter returns to data display mode.</p>	Code	Content	00	INHIBIT	01	ENABLE
Code	Content						
00	INHIBIT						
01	ENABLE						

8.1.2 Zero Adjustment Via the BT200

Display	Description
<pre> MENU A:DISPLAY B:SET C:ADJUST D:DISP SEL E:TOTAL SET F:PULSE SET HOME SET ADJ ESC </pre>	<p>Call up the menu screen and select "C:ADJUST"</p>
<p style="text-align: center;">↓</p> <pre> PARAM C01:ZERO TUNING ENABLE C02:MAGFLOW ZERO 0.05 C60:SELF CHECK GOOD DATA DIAG ESC </pre>	<p>Press the ENTER key to call the screen displaying the parameter sub items. Select C02:MAGFLOW ZERO</p>
<p style="text-align: center;">↓</p> <pre> SET C02:MAGFLOW ZERO 0.05 + 00.05 DIAG ESC </pre>	<p>Pressing the ENTER key causes the data setup screen to be displayed. If the security screen is displayed, enter the security code.*</p>
<p style="text-align: center;">↓</p> <pre> SET C02:MAGFLOW ZERO AUTOZERO FEED NO OK </pre>	<p>While "C02:MAGFLOW ZERO" is displayed, press the ENTER key once, then wait a few seconds and press again. "AUTO ZERO" is now displayed</p>
<p style="text-align: center;">↓</p> <pre> PARAM C01:ZERO TUNING ENABLE C02:MAGFLOW ZERO 0.02 C60:SELF CHECK GOOD DATA ESC </pre>	<p>After about 30 seconds, press the "F4" of the Function key causes the Menu screen to be displayed. The zero correction is displayed. Then the meter returns to data display mode.</p>

*For entry of the security code, see IM 1C0A11-01E

8.2 Self-diagnostics Functions

- The self-diagnostics function displays instrument internal errors, input/output signal abnormalities, setting errors, and other problems.
- When an alarm occurs, an alarm number announcing that an error has occurred is superimposed on the normal data display. However, alarms are only displayed during normal flow rate data display mode and when parameter numbers are changed in the setting mode. (Alarms are not displayed when data items are being changed.)
- When the BT200 is used, alarms are displayed in the A60 to N60 SELF CHECK parameter.

8.2.1 Display and Output Status during Alarm Occurrence

- If an error occurs, the panel display LED flashes and an alarm number is superimposed on the normal display. During this time the current output is fixed to 2.4mA or less, 4mA, HOLD or 21.6mA or more, as selected in 4-20 ALM OUT (out-put current during alarm).
- An alarm (status contact output) is output for any of the errors indicated in the table at right.

Display		LED	Contact output	Current output	Totalization pulse
AE	Display on BT				
00	GOOD	OFF	ON	Normally	Normally
01	ERROR	Flash- ing	OFF	Fixed (See note.)	Stop
02	μ P FAULT				
03	EEPROM FAULT				
04	A/D(H) FAULT				
05	A/D(L) FAULT				
06	SIGNAL OVERFLOW				
07	COIL OPEN				
08	VEL. SAPN>10m/s				
09	VEL. SPAN<0.3m/s				
10	P.SPAN>1000p/s				
11	P.SPAN>500m/s				
12	P.SPAN>25p/s				
13	P.SPAN>15p/s				
14	P.SPAN>10p/s				
15	P.SPAN>5p/s				
16	P.SPAN<0.0001p/s				
17	T.SPAN>1000p/s				
18	T.SPAN<0.0001p/s				
19	4-20 LMT ERROR				
20	EMPTY PIPE				
21	MULTI RANGE ERROR				

Note: As selected in 4-20 ALM OUT(output current during alarm)

8.2.2 Error Description and Countermeasures

AE	Display on BT	Error Contents	Countermeasures	
02	μ P FAULT	Microprocessor error	Contact the nearest Yokogawa office, or service center	
03	EEPROM FAULT	EEPROM error		
04	A/D(H) FAULT	A/D converter (high frequency side) error		
05	A/D(L) FAULT	A/D converter (low frequency side) error		
06	SIGNAL OVERFLOW	Excessive input signal		Check for the following : -Mixup of the signal, power supply, execution, and other cable. -Stray electrical currents in the measured liquid. -Improper grounding
07	COIL OPEN	Flow Tube coil open-circuit	Contact the nearest Yokogawa office, or service center	
08	VEL. SAPN>10m/s	Setting for span flow velocity exceeds 11 m/s	Change setting	
09	VEL. SAPN<0.3m/s	Setting for span flow velocity is 0.2m/s or below		
10	P.SPAN>1000p/s	Pulse output rate exceeds 1100 p/s, at 50% DUTY Pulse output rate exceeds 1000 p/s, at 0.5 ms pulse width		
11	P.SPAN>500p/s	Pulse output rate exceeds 500 p/s at 1 ms pulse width		
12	P.SPAN>25p/s	Pulse output rate exceeds 25 p/s at 20 ms pulse width		
13	P.SPAN>15p/s	Pulse output rate exceeds 15 p/s at 33 ms pulse width		
14	P.SPAN>10p/s	Pulse output rate exceeds 10 p/s at 50 ms pulse width		
15	P.SPAN>5p/s	Pulse output rate exceeds 5 p/s at 100 ms pulse width		
16	P.SPAN<0.0001p/s	Pulse output rate is 0.00005 p/s or below		
17	T.SPAN>1000p/s	Totalization rate exceeds 1100 p/s		
18	T.SPAN<0.0001p/s	Totalization rate is 0.00005 p/s or less		
19	4-20 LMT ERROR	Analog low limit > Analog high limit		
20	EMPTY PIPE	Pipe is not filled with fluid or insulating material attached to electrode.		Fill the flow tube with fluid or clean the flow tube inside
21	MULTI RANGE ERROR	In Auto 2 range, 1st range>2nd range		Change setting

9. MAINTENANCE

9.1 Loop Test (Test Output)

This function enables you to set up any desired value, and to output it from the converter. Since this function corresponds to flow rate totalization display and pulse output, this makes it possible to check operation of individual functions.

The test functions of status output are also provided.



IMPORTANT

- Test outputs take priority of the flow signal. Do not forget to return to the normal operation mode after the loop test.
- In case "BI DIRECTION" is set at OUTPUT FUNCTION (Parameter No. b10), the setting range is available -108 to +108. Please set the loop test value in +/- percentage based on the larger flow span within forward and reverse flow span.
- In case "AUTO 2 RANGES" is set at OUTPUT FUNCTION (Parameter No.b10), the loop test setting value should be set in percentage based on the second range.

9.1.1 Settings for Test Output Using Data Setting Keys

(1) Current Output (Corresponding to Flow Rate, Pulse and Totalization Display)

Display	Description						
	Call up the setting mode and display "H1" (test mode) and set "01". <table border="1" style="margin-top: 10px;"> <thead> <tr> <th>Code</th> <th>Content</th> </tr> </thead> <tbody> <tr> <td>00</td> <td>Normal operation</td> </tr> <tr> <td>01</td> <td>Test output</td> </tr> </tbody> </table>	Code	Content	00	Normal operation	01	Test output
Code	Content						
00	Normal operation						
01	Test output						
<p>Setting range : -8(-108) to 108%</p>	Display "H2" and set the value in % of maximum span. (The figure shows a 100% setting.)						

*These functions must be returned to their original status during flow rate measurements.

(2) Status Output

Display	Description								
	Call up the setting mode and display "H1" (test mode) and set "01". <table border="1" style="margin-top: 10px;"> <thead> <tr> <th>Code</th> <th>Content</th> </tr> </thead> <tbody> <tr> <td>00</td> <td>Normal operation</td> </tr> <tr> <td>01</td> <td>Test output</td> </tr> </tbody> </table>	Code	Content	00	Normal operation	01	Test output		
Code	Content								
00	Normal operation								
01	Test output								
	Select the mode of status to be output in "H3". <table border="1" style="margin-top: 10px;"> <thead> <tr> <th>Code</th> <th>Content</th> </tr> </thead> <tbody> <tr> <td>00</td> <td>Normal operation</td> </tr> <tr> <td>01</td> <td>Transistor contact (ON)</td> </tr> <tr> <td>02</td> <td>Transistor contact (OFF)</td> </tr> </tbody> </table>	Code	Content	00	Normal operation	01	Transistor contact (ON)	02	Transistor contact (OFF)
Code	Content								
00	Normal operation								
01	Transistor contact (ON)								
02	Transistor contact (OFF)								

*These functions must be returned to their original status during flow rate measurements.

9.1.2 Setting for Test Output Via the BT200

(1) Current Output (Corresponding to Flow Rate, Pulse and Totalization Display)

Display	Description						
	Select Test mode in parameter number "H01". <table border="1" style="margin-top: 10px;"> <thead> <tr> <th>Code</th> <th>Description</th> </tr> </thead> <tbody> <tr> <td>NORMAL</td> <td>Normal operation</td> </tr> <tr> <td>TEST</td> <td>Test output</td> </tr> </tbody> </table> Display "H02:OUTPUT VALUE" and set the value in % of maximum span. (The figure shows a 100% setting.)	Code	Description	NORMAL	Normal operation	TEST	Test output
Code	Description						
NORMAL	Normal operation						
TEST	Test output						

*These functions must be returned to their original status during flow rate measurements.

(2) Status Output

Display	Description														
	Call up the setting mode and display "H1" (test mode) and set "01". <table border="1" style="margin-top: 10px;"> <thead> <tr> <th>Code</th> <th>Content</th> </tr> </thead> <tbody> <tr> <td>NORMAL</td> <td>Normal operation</td> </tr> <tr> <td>TEST</td> <td>Test output</td> </tr> </tbody> </table> Select the mode of status to be output in "H03". <table border="1" style="margin-top: 10px;"> <thead> <tr> <th>Code</th> <th>Content</th> </tr> </thead> <tbody> <tr> <td>NORMAL</td> <td>Normal operation</td> </tr> <tr> <td>CLOSED(ON)</td> <td>Trarsistor contact (ON)</td> </tr> <tr> <td>OPEN(OFF)</td> <td>Trarsistor contact (OFF)</td> </tr> </tbody> </table>	Code	Content	NORMAL	Normal operation	TEST	Test output	Code	Content	NORMAL	Normal operation	CLOSED(ON)	Trarsistor contact (ON)	OPEN(OFF)	Trarsistor contact (OFF)
Code	Content														
NORMAL	Normal operation														
TEST	Test output														
Code	Content														
NORMAL	Normal operation														
CLOSED(ON)	Trarsistor contact (ON)														
OPEN(OFF)	Trarsistor contact (OFF)														

*These functions must be returned to their original status during flow rate measurements.

9.2 Fuse Replacement

WARNING

This instrument must be installed by expert engineer or skilled personnel. Fuse replacement is not permitted for operators.

The fuse holder is located under the display which has to be removed to allow fuse replacement. A spare fuse is taped to the cover of the converter.

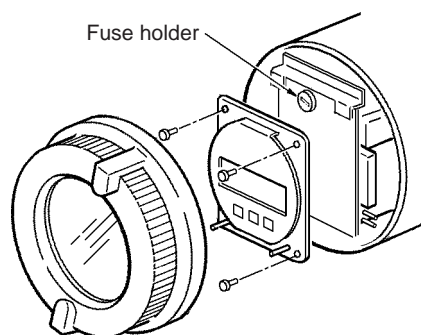

CAUTION

Before replacing the fuse, make sure to turn OFF the power supply and disconnect the power source. Use only specified fuses which should be obtained from your nearest Sales & Service Office. The use of other fuses might cause fire. After replacing the fuse, confirm that the connector of the display board has not loosened.

9.3 Trouble Shooting

Although magnetic flowmeters rarely require maintenance, failures occur when the instrument is not operating correctly. Since a failure is located by troubleshooting the receiving instrument information. This information will be described below.

(1) No Indication

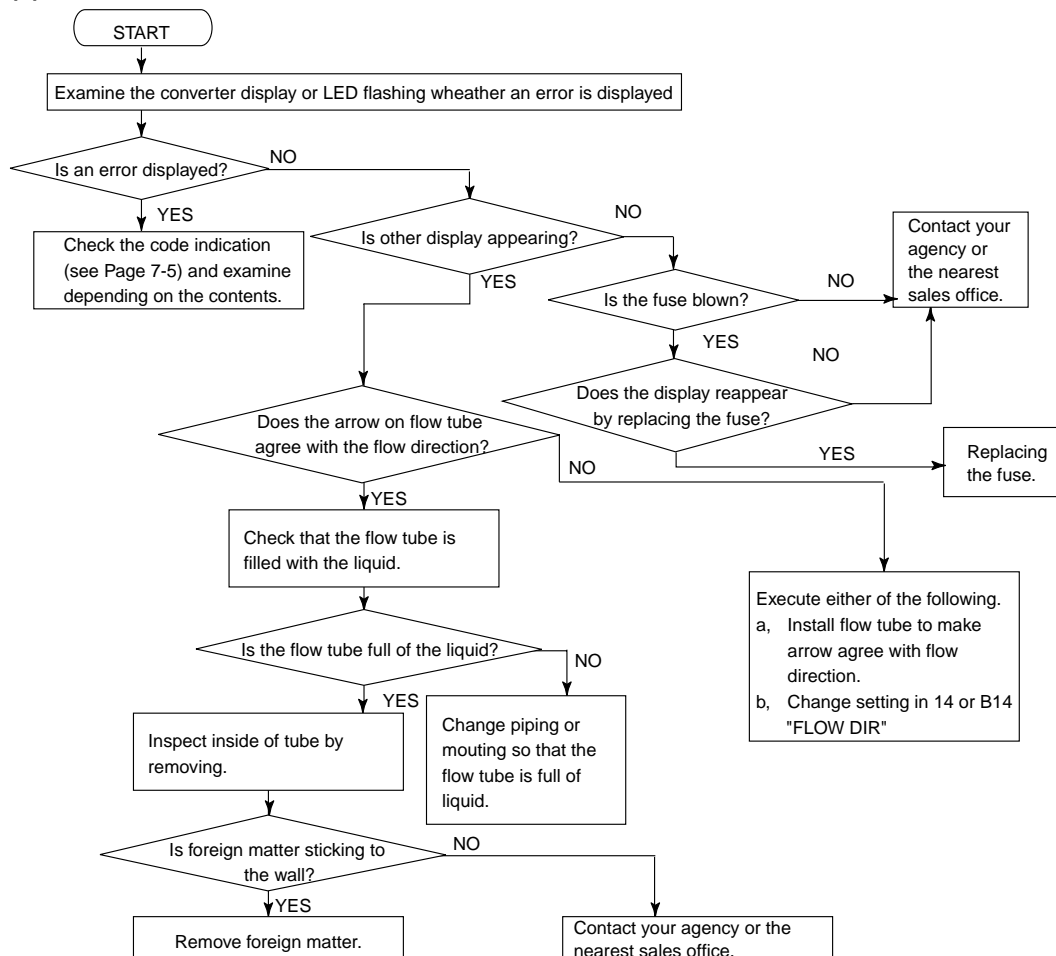

(2) Unstable Zero

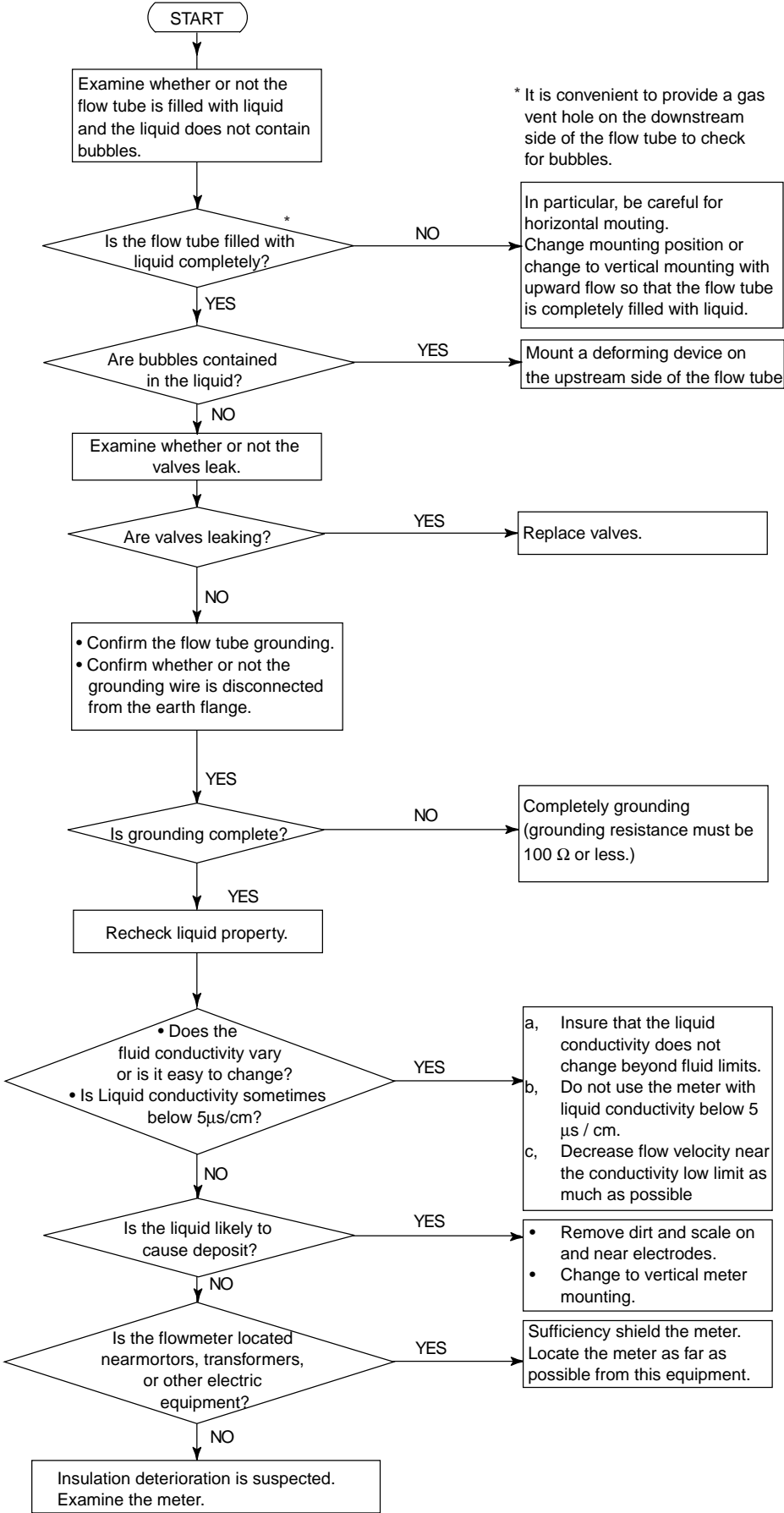

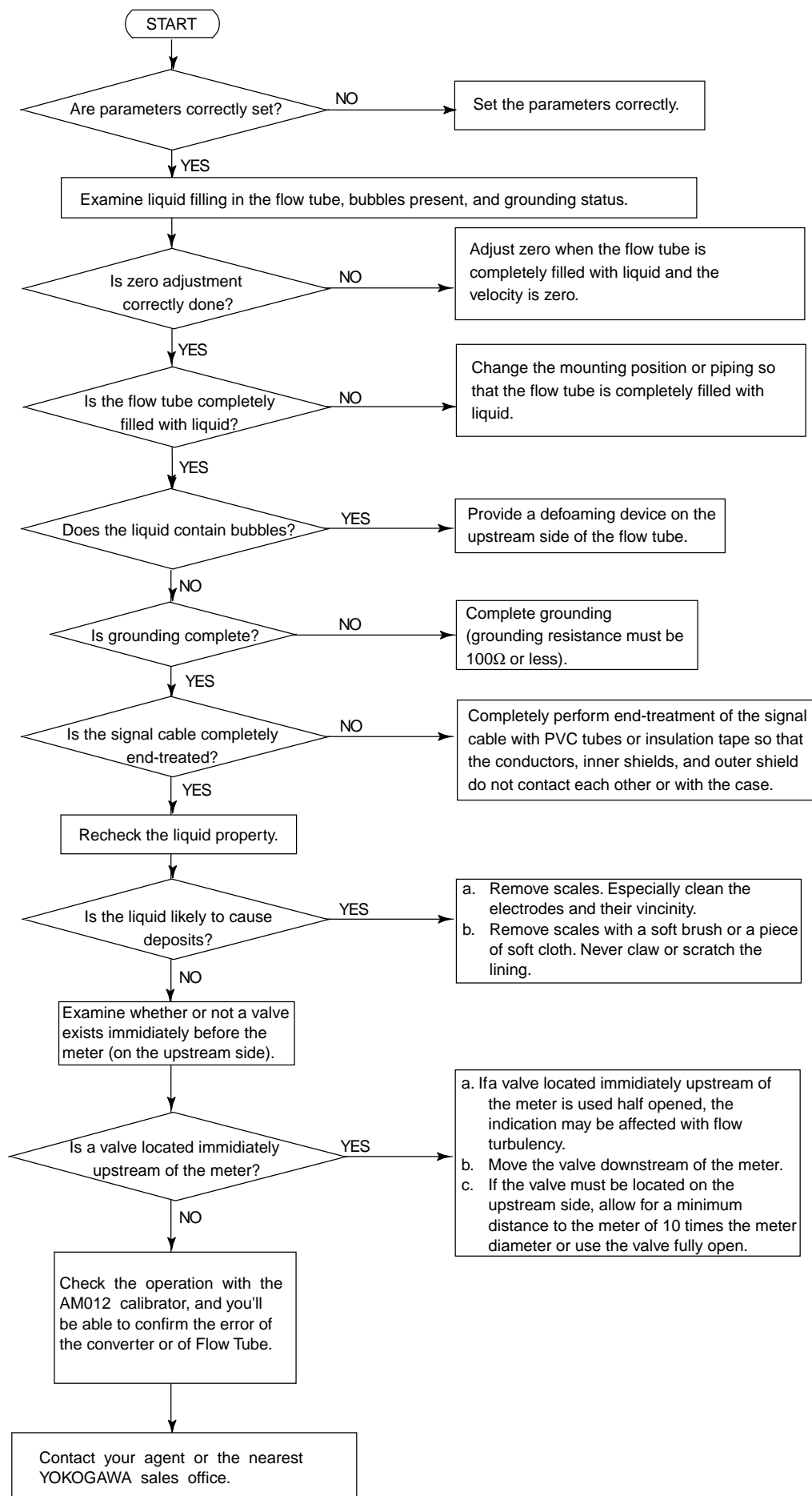
(3) Disagreement of Indication with Actual Flow Result

10. OUTLINE

STANDARD SPECIFICATIONS

Note 1: For models with no indicator, a hand-held terminal is necessary to set parameters.

Note 2: Pulse output, status output and alarm output use common terminals, therefore, these functions are not available at the same time.

Note 3: Please refer to GS 01E07F01-00E for Fieldbus communication type/(FB).

Excitation method: Dual frequency excitation

Output Signal(Note 3):

Current Output: 4 to 20 mA DC (Load resistance 750Ω maximum).

Transistor Contact Output(Open-collector):

Pulse, alarm or status output selected by parameter setting. Contact rating: 30 V DC (OFF), 200 mA (ON).

Communication (option)(Note 3):

BRAIN or HART (Superimposed on the 4 to 20 mA DC signal)

Load Resistance: (including cable resistance)

BRAIN: 250 to 600Ω

HART: 230 to 600Ω, depending on q'ty of field devices connected to the loop (multidrop mode)

Load Capacitance: 0.22 μF maximum

Load Inductance: 3.3 mH maximum

Distance from Power Line:

15 cm(0.6 ft) or more (Parallel wiring should be avoided.)

Input Impedance of Receiver Connected to the Receiving Resistance: 10kΩ or larger (at 2.4 kHz)

Maximum Cable Length:

2 km (6500 ft) (when polyethylene-insulated PVC-sheathed control cables (CEV cables) are used)

Note: HART is a registered trademark of the HART Communication Foundation.

Instantaneous Flow Rate Display Function:

Flow rate can be displayed either in engineering units or in percent of span. (for models with indicator)

Totalizer Display Function:

Totalized volume in any engineering unit can be displayed by setting a totalizing factor. (for models with indicator)

Damping Time Constant(Note 1):

Settable from 0.1 second to 200 seconds (63% response time).

Span Setting Function(Note 1):

Volumetric flow setting is available by setting volume unit, time unit, flow rate value and flow tube size.

Volume Unit: gallon(US), m³, L, cm³, barrel(=158.987L)

Velocity Unit: ft, m

Time Unit: sec., min., hour, day

Flow Tube Size: inch, mm

Pulse Output Function(Note 2), (Note 3):

Scaled pulse can be output by setting a pulse factor.

Pulse Width: Duty 50% or fixed pulse width (0.5, 1, 20, 33, 50, or 100 ms) - user selectable.

Output Rate: 0.0001 to 1000pps (when pulse output function is selected.)

Status Output Function(Note 2), (Note 3):

One of the following is selected by parameter setting.

- **Auto 2 Ranges Status Output:**

Indicates the selected range for automatic dual range function.

- **Forward and Reverse Status Output:**

Indicates the flow direction for forward and reverse flow measurement mode.

- **Totalization Status Output:**

Indicates that the internal totalized value exceeds the set value.

- **Low Limit Alarm:**

Indicates that flow rate is under the low limit set value.

Alarm Output Function(Note 2), (Note 3):

Indicates that an alarm occurs (Normal Close Fixed).

Self Diagnostics Function(Note 1):

Converter failure, flow tube failure, erroneous setting, etc. can be diagnosed and displayed.

Data Security During Power Failure:

Data storage by EEPROM - no back-up battery required.

Electrical Connection:

ANSI 1/2NPT female, DIN Pg13.5 female, ISO M20×1.5 female, JIS G1/2 female.

Terminal Connection:

M4 size screw terminal.

Case Material:

Aluminum alloy.
Coating: Polyurethane corrosion-resistant coating. Cover; Deep sea moss green (Munsell 0.6GY3.1/2.0)
Case; Frosty white (Munsell 2.5Y8.4/1.2)

Protection:

IP67, NEMA4X, JIS C0920 water tight type

Size:

- **General Purpose Type**

Lining	PFA	Ceramic	Polyurethane
Size in mm (inch)	2.5(0.1), 5(0.2), 10(0.4), 15(0.5), 25(1), 40(1.5), 50(2), 65(2.5), 80(3), 100(4), 125(5), 150(6), 200(8), 250(10), 300(12), 350(14), 400(16)	2.5(0.1), 5(0.2), 10(0.4), 15(0.5), 25(1), 40(1.5), 50(2), 80(3), 100(4), 150(6), 200(8)	25(1), 40(1.5), 50(2), 80(3), 100(4), 150(6), 200(8), 250(10), 300(12), 350(14), 400(16)

T01.EPS

- **Explosion Proof Type**

Lining	PFA	Ceramic
Size in mm (inch)	2.5(0.1), 5(0.2), 10(0.4), 15(0.5), 25(1), 40(1.5), 50(2), 65(2.5), 80(3), 100(4), 125(5), 150(6), 200(8), 250(10)*, 300(12)*, 350(14)*, 400(16)*	2.5(0.1), 5(0.2), 10(0.4), 15(0.5), 25(1), 40(1.5), 50(2), 80(3), 100(4), 150(6), 200(8)

T02.EPS

*250 to 400mm with flange connection are only for CENELEC ATEX or SAA.

250 and 300mm with wafer connection are only for general purpose use.

*65 and 125mm are only for CENELEC ATEX.

- **Sanitary Type**

Lining	PFA
Size in mm(inch)	25(1), 40(1.5), 50(2), 65(2.5), 80(3), 100(4)

T03.EPS

* 15 and 125mm flow tubes are available on request.

Coating:

Body:

- Size 2.5 to 100 mm(0.1 to 4 in.):
No coating (Stainless steel surface)
- Size 125 to 400 mm(5 to 16 in.):
Polyurethane corrosion-resistant coating.
Frosty white (Munsell 2.5Y8.4/1.2)

Flow Tube Material:

- Size 2.5 to 15 mm(0.1 to 0.5 in.)
Housing: Stainless steel (SCS11)
Mini-flange for wafer conn.: Stainless steel (SUS430)
Flange (15 mm(0.5 in.) only): Stainless steel (SUS304)
Pipe: Stainless steel (SCS13) or Alumina ceramic (99.9%)
- Size 25 to 100 mm(1 to 4 in.)
Housing: Stainless steel (SUS304)
Mini-flange for wafer conn.: Stainless steel (SUS430)
Flange: Stainless steel (SUS304)
Pipe: Stainless steel (SUS304)* or Alumina ceramic (99.9%)
- Size 125 to 400 mm(5 to 16 in.)
Housing: Carbon steel (SS400)
Flange: Carbon steel (SS400)
Pipe: Stainless steel (SUS304)* or Alumina ceramic (99.9% — Sizes 150 and 200 mm only)

* For PFA or Polyurethane lining

Wetted Part Material:

- Lining: Fluorocarbon PFA*, Alumina ceramic, Polyurethane.
*PFA is FDA approved material.
- Electrode: Stainless steel (SUS316L), Hastelloy C (equivalent to Hastelloy C-276), Titanium, Tantalum, Platinum-Iridium, Platinum-alumina cermet only for ceramic lining.
* For sanitary type, SUS316L only
- Earth Ring/Earth Electrode: Stainless steel (SUS316), Hastelloy C (equivalent to Hastelloy C-276), Titanium, PFA lining + Earth electrodes (Tantalum, Platinum-Iridium)
- Gasket:
 - VALQUA#7020 : Fluoro resin with filler (between flow tube body and earth ring; for ceramic lining)
 - VALQUA#4010 : Fluoro rubber, viton (between flow tube body and earth ring; for optional code /FRG)
 - Non-asbestos joint sheet sheathed with fluoro resin (between earth ring and process flange; for optional code /BCF or /BSF)
 - Chloroprene rubber (between earth ring and process flange; for optional code /BCC or /BSC)
 - EPDM, ethylene propylene rubber (for sanitary type)

* Other gaskets between flow tube body and earth ring;

- VALQUA#7026 : corrosion resistance gasket (Fluoro resin with carbon)
- VALQUA#4010 (Mixing#RCD970) :Alkali resistance gasket for PVC piping (Fluoro rubber)
- VALQUA#4010 (Mixing#RCD470) : Acid resistance gasket for PVC piping (Fluoro rubber)

* Contact Yokogawa office. (Refer to TI 1E6A0-06E.)
Union Joint: Stainless steel (SUS316L) for ceramic lining size 10 mm(0.4in.) or less.*

* Contact Yokogawa office if you use PVC union joints.
Ferrule (for sanitary type): SCS13

Electrode Construction:

- **General Purpose/Ex-proof Type**
PFA, Polyurethane Lining: External insertion type.
Ceramic Lining: Integral type.

• **Sanitary Type**

Internal insertion type
* Only PFA lining is available for sanitary type.

Note: Hastelloy is a registered trademark of Haynes International Inc.

STANDARD PERFORMANCE

Accuracy:

PFA and Ceramic Lining

PFA and Ceramic Lining (except /FB)

Size in mm (inch)	Span in m/s (ft/s)	Accuracy
2.5 to 15 (0.1 to 0.5)	0.3 to 1 (1 to 3)	0.5% of span
	1 to 10 (3 to 33)	0.25% of span (at indications below 50% of span)
		0.5% of rate (at indications 50% of span or more)
25 or larger (1)	0.3 to 1 (1 to 3)	0.25% of span (at indications below 50% of span)
		0.5% of rate (at indications 50% of span or more)
	1 to 10 (3 to 33)	0.1% of span (at indications below 20% of span)
		0.5% of rate (at indications 20% of span or more)

Polyurethane Lining (except /FB)

Size in mm (inch)	Span in m/s (ft/s)	Accuracy
25 or larger (1)	0.3 to 1 (1 to 3)	0.5% of span
	1 to 10 (3 to 33)	0.25% of span (at indications below 50% of span)
		0.5% of rate (at indications 50% of span or more)

PFA and Ceramic Lining (/FB)

Size in mm (inch)	Actual Flow Velocity in m/s (ft/s)	Accuracy
2.5 to 15 (0.1 to 0.5)	less than 0.3(1)	1.5mm/s
	0.3(1) or more	±0.5% of rate
25 or larger (1)	less than 0.15(0.5)	0.75mm/s
	0.15(0.5) or more	±0.5% of rate

Polyurethane Lining (/FB)

Size in mm (inch)	Actual Flow Velocity in m/s (ft/s)	Accuracy
25 or larger (1)	less than 0.3(1)	1.5mm/s
	0.3(1) or more	±0.5% of rate

T04.EPS

Repeatability: 0.1% of flowrate (minimum 1 mm/s)

Maximum Power Consumption: 12.5W

Insulation Resistance:

- 100MΩ between power terminals and ground terminal at 500 V DC.
- 100MΩ between power terminals and each output terminal at 500 V DC.
- 20MΩ between each output terminal and ground terminal at 100V DC.

Withstand Voltage :

1500 V AC between power terminals and ground terminal for 1 minute.

CAUTION

When performing the Voltage Breakdown Test, Insulation Resistance Test or any unpowered electrical test, wait 10 seconds after the power supply is turned off before removing the housing cover. Be sure to remove the Short Bar at terminal "G". After testing, return the Short Bar to its correct position. Screw tightening torque should be 1.18N-m(0.88ft-lb) or more, because the G-terminal is thought as a protective grounding and should conform to the Safety Requirements.

Safety Requirement Standards:

IEC1010, EN61010

EMC Conformity Standards:

EN61326
EN61000-3-2, EN61000-3-3
AS/NZS 2064

Grounding: 100Ω or less

- * In case of explosion proof type, the protective grounding must be connected to a suitable IS grounding system.
- * In case of JIS Flameproof type, JIS Class C(10Ω or less) or JIS Class A(10Ω or less) grounding system.

NORMAL OPERATING CONDITIONS

Ambient Temperature: -10 to 60°C (14 to 140°F)

Note: The minimum ambient temperature is -20°C is available only for these sizes 40 to 100 mm with SUS304 flange.

Ambient Humidity: 5 to 95%RH (no condensation)

Power Supply Voltage: -A1; Range 80 to 264 V AC, 47 to 63Hz/100 to 130 VDC, -D1; Range 20.4 to 28.8 V DC(except /FB)

Supplied Power and Max. Cable Length for 24 V DC version:

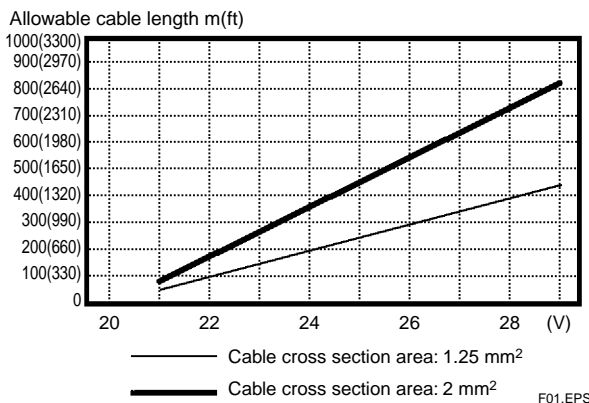

Altitude at installation side: Max.2000m above sea level

Installation category based on IEC1010: II(See Note)

Pollution level based on IEC1010: 2(See Note)

Note: • The "Installation category" implies the regulation for impulse withstand voltage. It is also called the "Overvoltage category". "II" applies to electrical equipment.

- "Pollution level" describes the degree to which a solid, liquid or gas which deteriorates dielectric strength is adhering. "2" applies to normal indoor atmosphere.

Fuse: 2A, 250V(Time - Lag type)

Fluid Conductivity:

Size 15 to 200mm(0.5 to 8in.); 5μS/cm or larger

Size 2.5 to 10mm(0.1 to 0.4in.); 20μS/cm or larger

*In case that size 250 or 300mm is used for high conductivity fluid (ex. caustic soda, seawater), please use the flange type.

Measurable Flow Rate Range:

SI Units (Size: mm, Flowrate: m³/h)

Size	Min. Range @ 0.3m/s	Max. Range @ 10m/s
2.5	0.0054	0.1767
5	0.0213	0.7068
10	0.0849	2.8274
15	0.1909	6.361
25	0.5302	17.671
40	1.3572	45.23
50	2.1206	70.68
65	3.584	119.45
80	5.429	180.95
100	8.483	282.74
125	13.254	441.7
150	19.086	636.1
200	33.93	1,131
250	53.02	1,767.1
300	76.35	2,544.6
350	103.91	3,463
400	135.72	4,523

T06.EPS

English Units (Size: inch, Flowrate: GPM)

Size	Min. Range @ 1.0ft/s	Max. Range @ 33ft/s
0.1	0.0241	0.8031
0.2	0.0964	3.212
0.4	0.3856	12.850
0.5	0.6024	20.078
1	2.4095	80.31
1.5	5.422	180.70
2	9.638	321.2
2.5	15.06	501.9
3	21.685	722.8
4	38.56	1,285.0
5	60.24	2007.8
6	86.74	2,891.3
8	154.21	5,140
10	240.95	8,031
12	347.0	11,565
14	472.3	15,741
16	616.9	20,560

T07.EPS

**Fluid Temperature and Pressure:
General Purpose /Explosion proof**

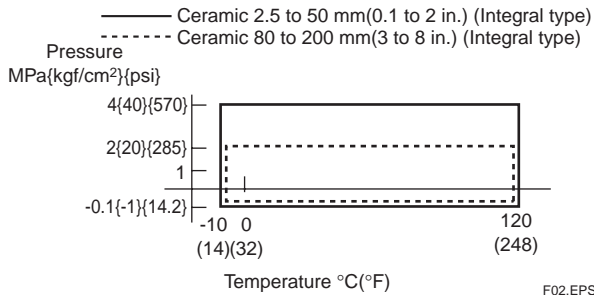
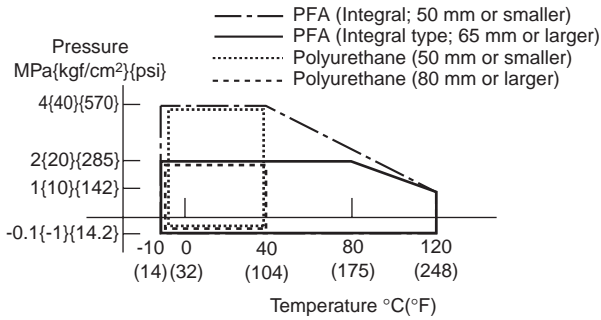

F02.EPS

Note 1: Those limits show maximum allowable fluid pressure for Flow Tube itself. Further fluid pressure should also be limited according to process connection.

Note 2: For Explosion proof type, maximum fluid pressure should be 2MPa or lower (for 350 and 400 mm, 1 MPa or lower) except CENELEC ATEX explosion proof version, and for fluid temperature refer to descriptions of "HAZARDOUS AREA CLASSIFICATION".

Sanitary

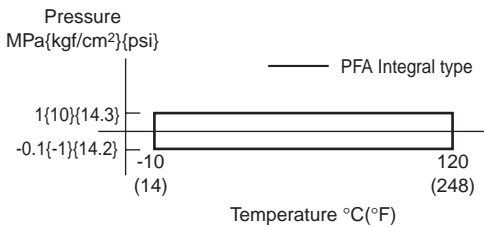

F02-2.EPS

Reasonable Figures for Thermal Shock of Ceramic Lining:

Size 2.5 to 25 mm(0.1 to 1 in.)

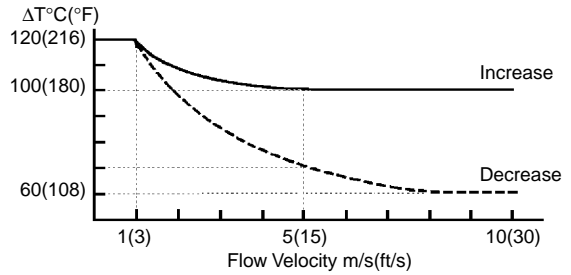

Size 40 and 50 mm(1.5 and 2 in.)

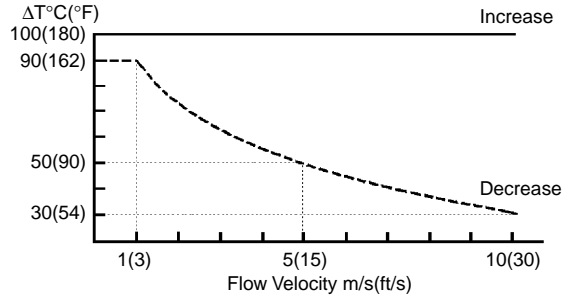

Size 80 to 200 mm(3 to 8 in.)

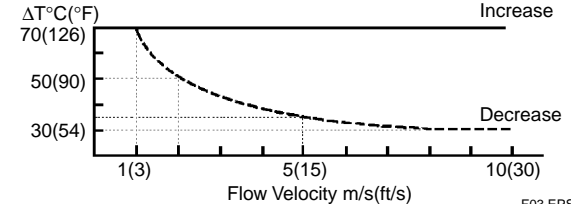

F03.EPS

■ TERMINAL CONNECTION

Terminal Symbols	Description
[P+ P-]] Pulse, alarm or status output
[I+ I-]] Current output 4 to 20 mA DC
[L/+ N/-]] Power supply
[Ⓧ]] Protective grounding

For Fieldbus Communication Type

Terminal Symbols	Description
[P+ P-]] Not used
[I+ I-]] Fieldbus communication signal
[L/+ N/-]] Power supply
[Ⓧ]] Protective grounding

T08.EPS

■ SIZING DATA

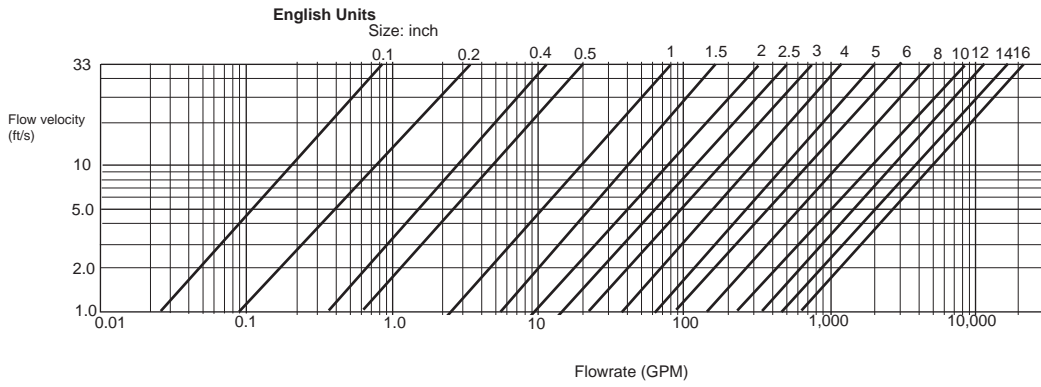
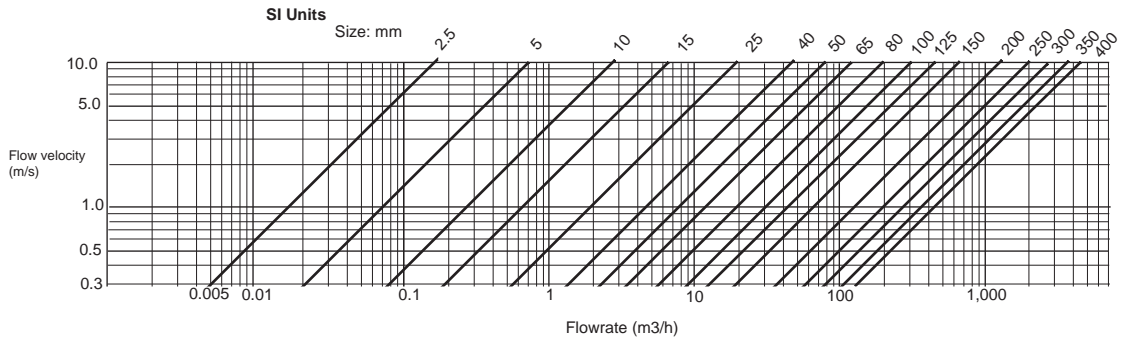

* Measurable flow velocity is from 0 m/s.

F29.EPS

■ MODEL AND SUFFIX CODE

General Purpose/Explosion Proof, Integral Type AE100/200 series

○: Available -: Not available



Model	Suffix Code	Description	Use								
			MG		SC		MN				
			Lining								
			A	U	C	A	C	A	C		
AE102	Size 2.5 mm (0.1in.)	○	-	○	○	○	○	○	○	Note 1
AE105	Size 5 mm (0.2in.)	○	-	○	○	○	○	○	○	Note 1
AE110	Size 10 mm (0.4in.)	○	-	○	○	○	○	○	○	Note 1
AE115	Size 15 mm (0.5in.)	○	-	○	○	○	○	○	○	Note 1
AE202	Size 25 mm (1in.)	○	○	○	○	○	○	○	○	
AE204	Size 40 mm (1.5in.)	○	○	○	○	○	○	○	○	
AE205	Size 50 mm (2in.)	○	○	○	○	○	○	○	○	
AE206	Size 65 mm (2.5in.)	○	-	-	-	-	-	-	-	
AE208	Size 80 mm (3in.)	○	○	○	○	○	○	○	○	
AE210	Size 100 mm (4in.)	○	○	○	○	○	○	○	○	
AE212	Size 125 mm (5in.)	○	-	-	-	-	-	-	-	
AE215	Size 150 mm (6in.)	○	○	○	○	○	○	○	○	
AE220	Size 200 mm (8in.)	○	○	○	○	○	○	○	○	
Use	MG	○	○	○	-	-	-	-	-	
	MN	-	-	-	-	-	○	○	○	Note 4
	SC	-	-	-	○	○	-	-	-	Note 5
Lining	-A	○	-	-	○	-	○	-	-	
	-U	-	○	-	-	-	-	-	-	
	-C	-	-	○	-	○	-	-	○	
Process Connection (Note 3)	K1	○	○	○	○	○	○	○	○	Not available with 65/125mm
	K2	○	○	○	○	○	○	○	○	
	B1	○	○	○	○	○	○	○	○	
	B2	○	○	○	○	○	○	○	○	Not available with 65/125mm
	E2	○	○	○	○	○	○	○	○	
	E4	○	○	○	-	-	-	-	○	Note 7 Size 80 mm(3in.) or larger
	H1	○	○	○	○	○	○	○	○	
	J1	○	○	○	-	-	-	-	-	} Not available with 65/125mm
	J2	○	○	-	-	-	-	-	-	
	A1	○	○	-	○	-	○	-	○	
	A2	○	○	-	○	-	○	-	○	} Size 150/200mm (6/8in.)only Note 2
	D1	○	○	-	○	-	○	-	○	
	D2	○	○	-	○	-	○	-	○	} Note 7 Size 80/100/150/200mm only
D4	○	○	-	-	-	-	-	○		
G1	○	○	-	○	-	○	-	○	} Ceramic lining, size 2.5/ 5/10mm only	
U1	-	-	○	-	○	-	○	-		
U2	-	-	○	-	○	-	○	-		
U3	-	-	○	-	○	-	○	-		
U3	Union Joint (1/4NPT or 3/8NPT)	-	-	○	-	○	-	○		
Electrode Material	-L	○	○	-	○	-	○	-	-	} Not available with 65/125mm
	-P	○	-	-	○	-	○	-	○	
	-E	-	-	○	-	○	-	○	-	
	-H	○	-	-	○	-	○	-	○	
	-T	○	-	-	○	-	○	-	○	
	-V	○	-	-	○	-	○	-	○	
Earth Ring/Earth Electrode Material	S	○	○	○	○	○	○	○	○	Note 6
	P	○	-	○	○	○	○	○	○	
	N	○	○	○	○	○	○	○	○	Must for ceramic, 2.5/5/10mm
	H	○	-	○	○	○	○	○	○	
	T	○	-	○	○	○	○	○	○	Not available with 65/125mm Note 6
	V	○	-	○	○	○	○	○	○	
Electrical Connection	J	○	○	○	○	○	-	-	-	
	A	○	○	○	-	-	○	○	○	
	D	○	○	○	-	-	○	○	○	
	M	○	○	○	-	-	○	○	○	
Power Supply	-A1	○	○	○	○	○	○	○	○	
	-D1	○	○	○	○	○	○	○	○	
Indicator	DH	..	○	○	○	○	○	○	○	○	
	DV	..	○	○	○	○	○	○	○	○	
	N	...	○	○	○	-	-	○	○	○	
Optional Code		<input type="checkbox"/> Refer to "Optional Specifications."									

T11.EPS

- Note 1: Process connection for size 2.5 to 10mm(0.1 to 0.4in.), wafer type is equal to one for 15mm(0.5in.). Provide 15mm process flanges for these flow tubes.
- Note 2: Select PN16 when requirement of PN10 for sizes 80mm(3in.) to 150mm(6in) because of same mating dimensions. Not available with 65, 125mm.
- Note 3: Flange type is available for size 15mm or larger, PFA or Polyurethane lining.
- Note 4: Select ANSI 1/2NPT female electrical connection(code A) in case of requirement of FM/CSA explosion proof type. For CENELEC ATEX explosion proof type, select ANSI 1/2NPT (code A) or ISO M20×1.5(code M) electrical connection.
- Note 5: Select JIS G1/2 female electrical connection (code J) and optional code /JF3 with /G11, /G12 in case of requirement of JIS Flameproof type.
- Note 6: Platinum-iridium and Tantalum earth electrodes are not available with 65, 125mm and ceramics 150, 200mm.
- Note 7: Select "PN40" when requirement of PN10, PN16, PN25 for sizes 50mm or less wafer or flange process connection because of same mating dimension. "PN40" is available for CENELEC ATEX, but not available for FM, CSA, or SAA ex-proof version.

General Purpose /Explosion Proof, Integral Type AE300 series

○: Available -: Not available

Model	Suffix Code	Description	Use			
			MG	MN		
			Lining			
			A	U	A	
AE325	Size 250mm (10in.)	○	○	○	
AE330	Size 300mm (12in.)	○	○	○	
AE335	Size 350mm (14in.)	○	○	○	
AE340	Size 400mm (16in.)	○	○	○	
Use	MG MN	General Purpose Ex-proof(CENELEC ATEX,SAA)	○ -	○ -	○ ○	Note
Lining	-A -U	Fluorocarbon PFA Polyurethane	○ -	- ○	○ -	
Process Connection	K1 B1 E2 H1 J1 J2 A1 A2 D1 D2 G1	JIS 10K wafer ANSI 150 wafer DIN PN10/16 wafer JIS F12 wafer JIS 10K flange JIS 20K flange ANSI 150 flange ANSI 300 flange DIN PN10 flange DIN PN16 flange JIS F12(JIS75M) flange	○ ○ ○ ○ ○ ○ ○ ○ ○ ○ ○	○ ○ ○ ○ ○ ○ ○ ○ ○ ○ ○	- - - - ○ ○ ○ ○ ○ ○ ○	Only for size 250, 300mm Only for size 250, 300mm Only for size 250, 300mm Only for size 250, 300mm Only for size 250, 300mm Only for size 250, 300mm Only for size 250, 300mm Only for size 250, 300mm
Electrode Material	-L -P -H -T -V	Stainless Steel (SUS316L) Platinum-iridium Hastelloy C276 equivalent Tantalum Titanium	○ ○ ○ ○ ○	○ - - - -	○ ○ ○ ○ ○	Only for flange type Only for flange type Only for flange type Only for flange type
Earth Ring Material	S H V N	Stainless Steel (SUS316) Hastelloy C276 equivalent Titanium None	○ ○ ○ ○	○ - - ○	○ ○ ○ ○	Only for flange type Only for flange type
Electrical Connection	J A D M	JIS G1/2 female ANSI 1/2NPT female DIN Pg13.5 female ISO M20×1.5 female	○ ○ ○ ○	○ ○ ○ ○	- ○ ○ ○	
Power Supply	-A1 -D1	80 to 264 V AC/100 to 130 V DC 20.4 to 28.8 V DC	○ ○	○ ○	○ ○	
Indicator	DH DV N	7seg.LCD(Horizontal Mounting) 7seg.LCD(Vertical Mounting) None	○ ○ ○	○ ○ ○	○ ○ ○	Note   
Optional Code		<input type="checkbox"/> Refer to "Optional Specifications."				

Note : For CENELEC ATEX explosion proof type, select ANSI 1/2NPT (code A) or ISO M20×1.5 (code M) electrical connection.

T12.EPS

Sanitary, Integral Type

Model	Suffix code	Description
AE202	Size 25 mm(1in.)
AE204	Size 40 mm(1.5in.)
AE205	Size 50 mm(2in.)
AE206	Size 65 mm(2.5in.)
AE208	Size 80 mm(3in.)
AE210	Size 100 mm(4in.)
Use	MH	Sanitary type
Lining	-A	PFA
Process Connection	C1	ISO(IDF) clamp
Electrode Material	-L	Stainless steel (SUS316L)
Earth Ring	N	None
Electrical Connection	J A D M	JIS G1/2 femal ANSI 1/2 NPT female DIN Pg13.5 female ISO M20 × 1.5 female
Power Supply	-A1 -D1	80 to 264 V AC /100 to 130 V DC 20.4 to 28.8V DC
Indicator	DH DV N	7Seg. LCD (Horizontal Mounting) 7Seg. LCD (Vertical Mounting) None
Optional Code		<input type="checkbox"/> Refer to Optional Specifications.

T17.EPS

Optional Specifications

○: Available –: Not available

Item	Specification	Applicable Model									Code
		General			Ex-proof			Sanitary			
		AE***MG	AE14	AE***DG	AE***MN	AE***SC	AE14	AE***DN	AE***MH	AE***DH	
Waterproof Gland	Waterproof glands are attached to all wiring ports. For JIS G1/2 only.	○	○	○	–	–	–	–	○	○	/ECG
Waterproof Gland with Union Joint	Waterproof glands (union joint) are attached to all wiring ports. For JIS G1/2 only.	○	○	○	–	–	–	–	○	○	/ECU
Gaskets for PVC pipe	Gaskets are attached between earth ring and flow tube. (Not available with 65, 125mm)	○	–	○	○	○	–	○	–	–	/FRG
DC Noise Suppression	Eliminating DC Noise (Size 15mm(0.5in.) or larger: Conductivity 50μS/cm or higher.)	○	○	–	○	○	○	–	○	○	/ELC
Lightning Protector	Built-in Lightning Protector(Only for 24VDC version)	○	○	–	○	○	○	–	○	○	/A
BRAIN Communication(Note 1)	Digital Communication with BRAIN protocol	○	○	–	○	○	○	–	○	○	/BR
HART Communication(Note 1)	Digital Communication with HART protocol	○	○	–	○	–	○	–	○	○	/HART
FOUNDATION Fieldbus Communication (Note 1)	Digital Communication with FOUNDATION Fieldbus protocol (except 24 VDC version)	○	○	–	Note 7 ○	–	Note 7 ○	–	○	–	/FB
PID/LM function for FOUNDATION Fieldbus (Note 6)	PID control function and Link Master function	○	○	–	Note 7 ○	–	Note 7 ○	–	○	–	/LC1
Epoxy Coating	Coating is changed to epoxy coating.	○	○	○	○	○	○	○	–	–	/EPF
High Anti-corrosion Coating	Coating is changed to three-layer coating(Urethane coating on two-layer Epoxy coating)	○	○	○	○	○	○	○	–	–	/X2
Material Certificate(Note 2)	Reproduced material certificate for pipe, electrode, earth ring, mini-flange and flange (depends on spec.).	○	–	○	○	○	–	○	–	–	/M01
Bolt & Nut Assembly(Note 3)	Carbon steel bolts/nuts and chloroprene gaskets assembly for wafer type	○	–	○	○	○	–	○	–	–	/BCC
	Carbon steel bolts/nuts and non-asbestos PTFE-wrapped gaskets assembly for wafer type	○	–	○	○	○	–	○	–	–	/BCF
	Stainless steel bolts/nuts and chloroprene gaskets assembly for wafer type	○	–	○	○	○	–	○	–	–	/BSC
	Stainless steel bolts/nuts and non-asbestos PTFE-wrapped gaskets assembly for wafer type	○	–	○	○	○	–	○	–	–	/BSF
DHC use (for size 100 to 400mm)	Condensation proof for District Heating and Cooling use. Terminal box: urethane resin potting. Wired 30m signal cable at factory.	–	–	○	–	–	–	–	–	–	/DHC
FM Approval(Note 4)	FM Explosion proof/FM Nonincendive	–	–	–	○	–	○	○	–	–	/FF1/FN1
CENELEC ATEX Certification (KEMA Approval)	CENELEC ATEX Explosion proof	–	–	–	○	–	○	○	–	–	/KF2
CSA Certification(Note 4)	CSA Explosion proof/CSA Nonincendive	–	–	–	○	–	○	○	–	–	/CF1/CN1
SAA Certification	SAA Explosion proof	–	–	–	○	–	○	○	–	–	/SF1
JIS Flameproof (Note 4)(Note 5)	JIS Flameproof type	–	–	–	–	(Note 5)	–	–	–	–	/JF3
Flameproof Packing Adapter for JIS Flameproof (Note 5) (Only for JIS G1/2 electrical connection)	One Flameproof Packing Adapter and a blind plug are attached.(only for DC power supply)	–	–	–	–	(Note 5)	–	–	–	–	/G11
	Two Flameproof Packing Adapters are attached.(Not apply for one port wiring.)	–	–	–	–	(Note 5)	–	–	–	–	/G12
GOST Certification	Calibration Certificate for GOST (only for products produced at YMF)	○	○	○	○	–	○	○	○	○	/GOS
Silicon Rubber Gasket for sanitary type	In case of fluid temp. over 120°C (248°F), 160°C (320°F) max. (Not available with 65mm)	–	–	–	–	–	–	–	–	○	/SRG
Mirror Finished Ceramics	Mirror Finishing on the inside of ceramic tube (Rmax.<=1 micro-meter)	○	–	○	○	○	–	○	–	–	/MRR
180deg. Rotated Converter	180deg. rotated converter for reversed flow direction	○	–	–	○	○	–	–	○	–	/CRC
Oil-prohibited Use	Degreased cleansing treatment	○	–	○	○	○	–	○	–	–	/K1
Oil-prohibited Use with Dehydrating Treatment	Degreased cleansing treatment; Packing with desiccant	○	–	○	○	○	–	○	–	–	/K5
Hydrostatics Test Certificate	Test pressure depends on process connection (Test duration 10 minutes) Test result is full in NOTE of QIC	○	–	○	○	○	–	○	–	–	/T01
Calibration Certificate	Level 2:Declaration and Calibration Equipment List	○	○	○	○	○	○	○	○	○	/L2
	Level 3:Declaration and Primary Standard List	○	○	○	○	○	○	○	○	○	/L3
	Level 4:Declaration and YOKOGAWA Measuring	○	○	○	○	○	○	○	○	○	/L4

Note 1: Either BRAIN, HART, or FOUNDATION Fieldbus communication can be selected.
 Note 2: In case of requirement of EN10204 3.1B for Material Certificate, contact Yokogawa office.
 Note 3: It is available only for JIS 10K wafer, JIS 20K wafer or ANSI 150 wafer type, not available with 65, 125, 250 or 300mm.
 Note 4: It is available only for size 2.5 to 200mm(0.1 to 8 in).
 Note 5: Select optional code /JF3 with /G11 or /G12 in case of requirement of JIS Flameproof type. /G11 is selectable only for DC power supply and 4-conductor cable use.
 Note 6: Optional code /LC1 is a function for Fieldbus communication. Optional code /FB must be selected together with /LC1.
 Note 7: Ex-proof Fieldbus communication is available only for CENELEC ATEX ex-proof version.

T19.EPS

EXTERNAL DIMENSIONS

Integral Magnetic Flowmeter

2.5 to 15mm(0.1 to 0.5in.) Wafer Type

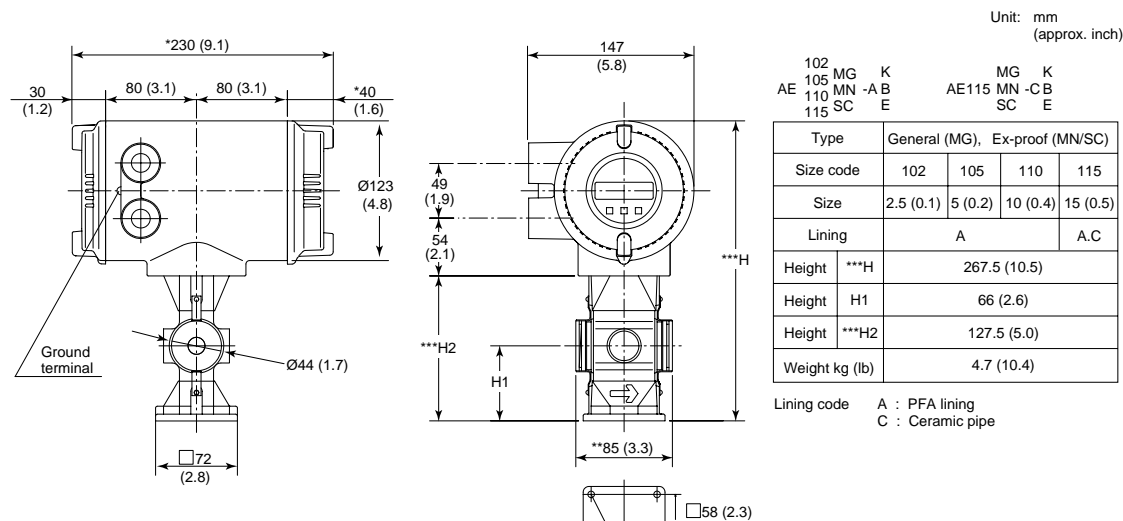

- * The length marked as * is shorter by approx. 10mm(0.4 in.) for non indicator type.
- ** The face-to-face length is longer by approx. 22mm(0.87 in.) for earth ring P, T
- ** The face-to-face length is shorter by approx. 6mm(0.24 in.) for non earth ring type.
- ** The face-to-face length is longer by approx. 2mm(0.08 in.) for PFA lining with optional code/FRG.
- *** The height marked as *** is shorter by approx. 2.5mm(0.1 in.) for ex-proof type.

F04.EPS

2.5 to 10mm(0.1 to 0.4in.) Union Joint Type

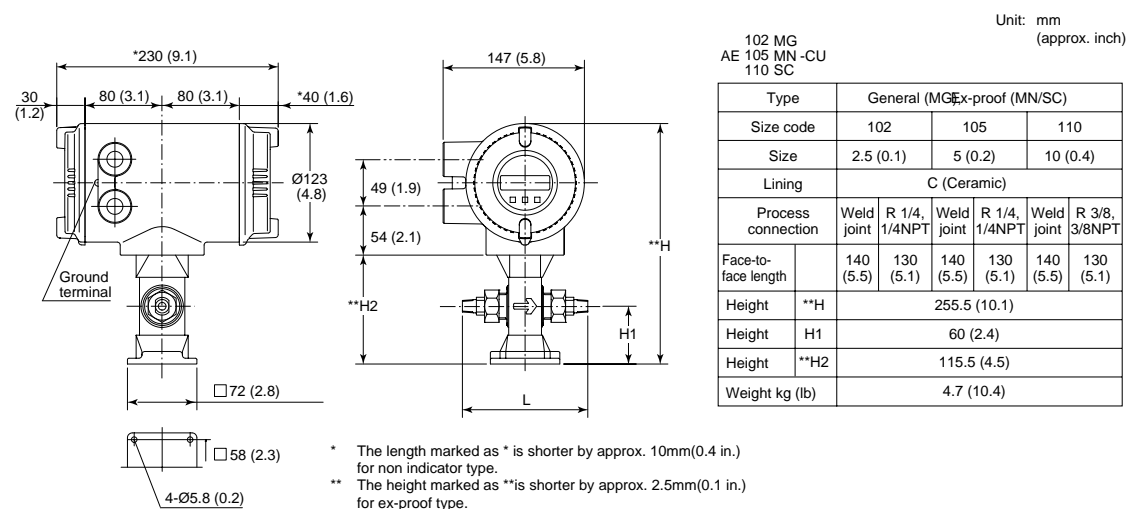

- * The length marked as * is shorter by approx. 10mm(0.4 in.) for non indicator type.
- ** The height marked as ** is shorter by approx. 2.5mm(0.1 in.) for ex-proof type.

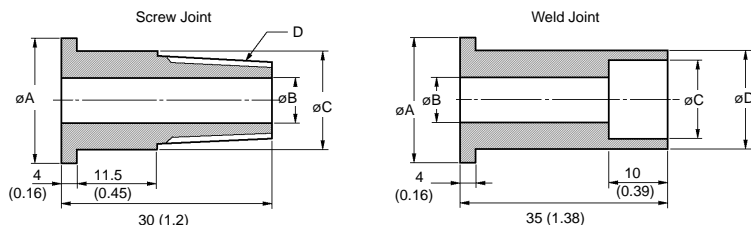

SIZE	A	B	C	D
2.5(0.1)	22(0.87)	8(0.31)	18.5(0.73)	R1/4(PT1/4)
	22(0.87)	8(0.31)	18.5(0.73)	NPT1/4
5(0.2)	22(0.87)	8(0.31)	18.5(0.73)	R1/4(PT1/4)
	22(0.87)	8(0.31)	18.5(0.73)	NPT1/4
10(0.4)	25(0.98)	10(0.39)	22.5(0.89)	R3/8(PT3/8)
	25(0.98)	10(0.39)	22.5(0.89)	NPT3/8

SIZE	A	B	C	D
2.5(0.1)	22(0.87)	8(0.31)	14.3(0.56)	18.5(0.73)
5(0.2)	22(0.87)	8(0.31)	14.3(0.56)	18.5(0.73)
10(0.4)	25(0.98)	10(0.39)	17.8(0.70)	22.5(0.89)

F05.EPS

25 to 100mm(1 to 4in.) Wafer Type

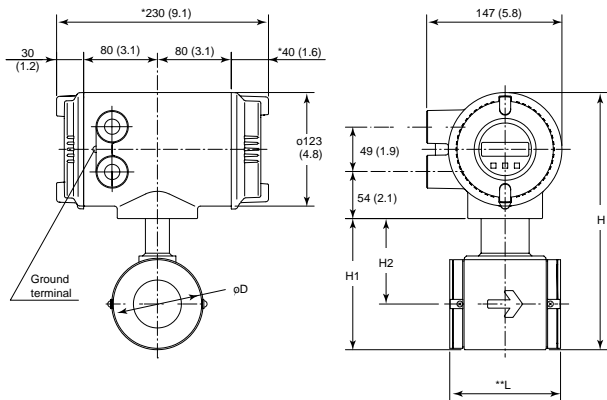

202 MG K
204 MN AB
205 SC CE
208 H
210

Unit: mm
(approx. inch)

Lining code A: PFA lining U: Polyurethane rubber lining C: Ceramic pipe

Type	General (MG)										Ex-proof (MN/SC)							
Size code	202	204	205	206	208	210	208	210	202	204	205	206	208	210	208	210		
Size	25 (1)	40 (1.5)	50 (2)	65 (2.5)	80 (3)	100 (4)	80 (3)	100 (4)	25 (1)	40 (1.5)	50 (2)	65 (2.5)	80 (3)	100 (4)	80 (3)	100 (4)		
Lining	A, U, C			A	A, U	C	A, C			A			C					
Face-to-face length	**L	93 (3.7)	106 (4.2)	120 (4.7)	120 (4.7)	160 (6.3)	180 (7.1)	160 (6.3)	180 (7.1)	93 (3.7)	106 (4.2)	120 (4.7)	120 (4.7)	160 (6.3)	180 (7.1)	160 (6.3)	180 (7.1)	
Outer diameter	D	68 (2.7)	86 (3.4)	99 (3.9)	117 (4.6)	129 (5.1)	155 (6.1)	129 (5.1)	155 (6.1)	68 (2.7)	86 (3.4)	99 (3.9)	117 (4.6)	129 (5.1)	155 (6.1)	129 (5.1)	155 (6.1)	
Height	H	251 (9.9)	271 (10.7)	284 (11.2)	302 (11.9)	324 (12.7)	350 (13.8)	314 (12.3)	350 (13.8)	249 (9.8)	269 (10.6)	282 (11.1)	300 (11.8)	322 (12.7)	348 (13.7)	312 (12.3)	348 (13.7)	
Height	H1	111 (4.4)	131 (5.2)	144 (5.6)	162 (6.4)	184 (7.2)	210 (8.2)	174 (6.8)	210 (8.2)	109 (4.3)	129 (5.1)	142 (5.6)	160 (6.3)	182 (7.1)	208 (8.2)	172 (6.8)	208 (8.2)	
Height	H2	77 (3.0)	88 (3.4)	94 (3.7)	104 (4.1)	119 (4.7)	132 (5.2)	109 (4.3)	132 (5.2)	75 (3.0)	86 (3.4)	92 (3.6)	102 (4.0)	117 (4.6)	130 (5.1)	107 (4.2)	130 (5.1)	
Weight kg (lb)		4.6 (10.1)	5.5 (12.1)	6.5 (14.3)	7.5 (16.5)	9.6 (21.2)	12.5 (27.6)	9.2 (20.3)	12.3 (27.1)	4.6 (10.1)	5.5 (12.1)	6.5 (14.3)	7.5 (16.5)	9.6 (21.2)	12.5 (27.6)	9.2 (20.3)	12.3 (27.1)	

- * The length marked as * is shorter by approx. 10mm(0.4 in.) for non indicator type.
- ** The face-to-face length is longer by approx. 22mm(0.87 in.) for earth ring P, T
- ** The face-to-face length is shorter by approx. 6mm(0.24 in.) for non earth ring type.
- ** The face-to-face length is longer by approx. 2mm(0.08 in.) for PFA lining with optional code/FRG.

F06.EPS

125 to 200mm(5 to 8in.) Wafer Type

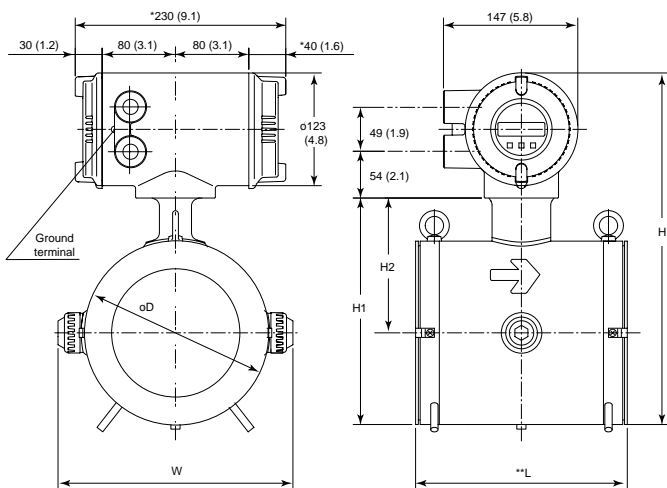

212 MG K
215 MN AB
220 SC UE
H

Unit: mm
(approx. inch)

Type	General (MG)			Ex-proof (MN/SC)			
Size code	212	215	220	212	215	220	
Size	125 (5)	150 (6)	200 (8)	125 (5)	150 (6)	200 (8)	
Lining	A			A, U			
Face-to-face length	**L	230 (9.1)	230 (9.1)	300 (11.8)	230 (9.1)	300 (11.8)	
Outer diameter	D	175 (6.9)	200 (7.9)	250 (9.8)	175 (6.9)	200 (7.9)	250 (9.8)
Height	H	367 (14.4)	392 (15.4)	442 (17.4)	365 (14.4)	390 (15.4)	440 (17.3)
Height	H1	227 (8.9)	252 (9.9)	302 (11.9)	225 (8.9)	250 (9.8)	300 (11.8)
Height	H2	140 (5.5)	152 (6.0)	177 (7.0)	138 (5.4)	150 (5.9)	175 (6.9)
Width	W	230 (9.1)	256 (10.1)	307 (12.1)	230 (9.1)	256 (10.1)	307 (12.1)
Weight kg (lb)		18 (39.7)	20.2 (44.5)	30.7 (67.6)	18 (39.7)	23.2 (51.1)	35.7 (68.6)

Lining code A: PFA lining
U: Polyurethane rubber lining

- * The length marked as * is shorter by approx. 10mm(0.4 in.) for non indicator type.
- ** The face-to-face length is shorter by approx. 6mm(0.24 in.) for non earth ring type.
- ** The face-to-face length is longer by approx. 30mm(1.18 in.) for earth ring P, T.
- ** The face-to-face length is longer by approx. 2mm(0.08 in.) for optional code/FRG.

F07.EPS

150 and 200mm(6 and 8in.) Ceramic Lining

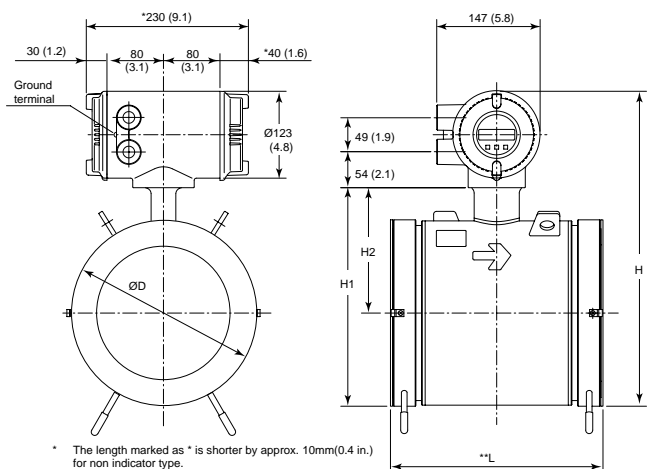

AE 215 MG K
220 MN AB
SC CE
H

Unit: mm
(approx. inch)

Type	General (MG)		Ex-proof (MN/SC)		
Size code	215	220	215	220	
Size	150 (6.0)	200 (8.0)	150 (6.0)	200 (8.0)	
Lining	C (Ceramic)				
Face-to-face length	**L	232 (9.2)	302 (11.9)	232 (9.2)	302 (11.9)
Outer diameter	D	214 (8.4)	264 (10.4)	214 (8.4)	264 (10.4)
Height	H	406 (16.0)	456 (18.0)	404 (15.9)	454 (17.9)
Height	H1	266 (10.5)	316 (12.4)	264 (10.4)	314 (12.4)
Height	H2	159 (6.3)	184 (7.2)	157 (6.2)	182 (7.2)
Weight kg (lb)		23.9 (52.6)	35.9 (79.1)	26.9 (59.3)	40.9 (90.1)

F08.EPS

- * The length marked as * is shorter by approx. 10mm(0.4 in.) for non indicator type.
- ** The face-to-face length is shorter by approx. 6mm(0.24 in.) for non earth ring type.

250 to 300mm(10 to 12in.) Wafer Type

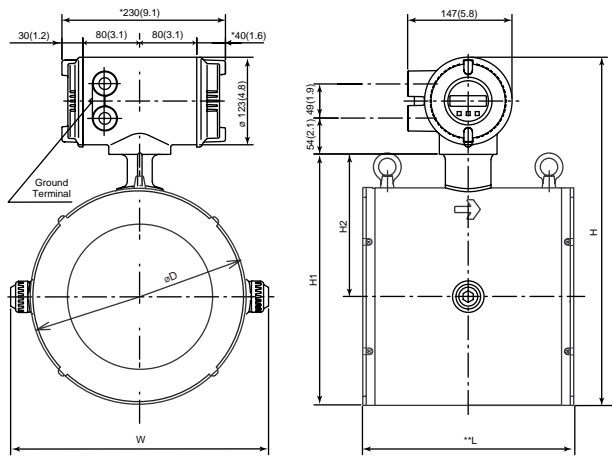

		K AE 325 MG-AB 300 UE H	
Type	General (MG)		
Size code	325	300	
Size	250 (10)	300 (12)	
Lining	A, U		
Face-to-face length	**L	300 (11.8)	350 (13.8)
Outer diameter	D	310 (12.2)	358 (14.1)
Height	H	502 (19.8)	550 (21.7)
Height	H1	362 (14.3)	410 (16.1)
Height	H2	207 (8.1)	231 (9.1)
Width	W	366 (14.4)	415 (16.3)
Weight kg (lb)		35.3 (77.8)	44.6(98.3)

Lining code A : PFA lining
U : Polyurethane rubber lining
* The length marked as * is shorter by approx. 10mm(0.4 in.) for non indicator type.
** The face-to-face length is shorter by approx. 2mm(0.08 in.) for non earth ring type.

15mm(0.5in.) Flange Type

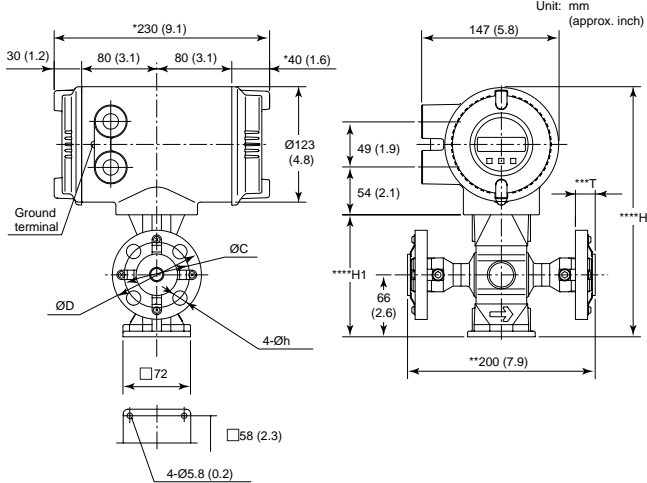

* The length marked as * is shorter by approx. 10mm(0.4 in.) for non indicator type.
** The face-to-face length is longer by approx. 22mm(0.87 in.) for earth ring P, T.
*** The thickness (T) is longer by approx. 11mm(0.43 in.) for earth ring P, T.
**** The face-to-face length is shorter by approx. 6mm(0.24 in.) for non earth ring type.
***** The thickness (T) is shorter by approx. 3mm(0.12 in.) for non earth ring type.
***** The face-to-face length is longer by approx. 2mm(0.08 in.) for optional code /FRG.
***** The thickness (T) is longer by approx. 1mm(0.04 in.) for optional code /FRG.
***** The height is shorter by approx. 2.5mm(0.1 in.) for ex-proof type.

25 to 50mm(1 to 2in.) Flange Type

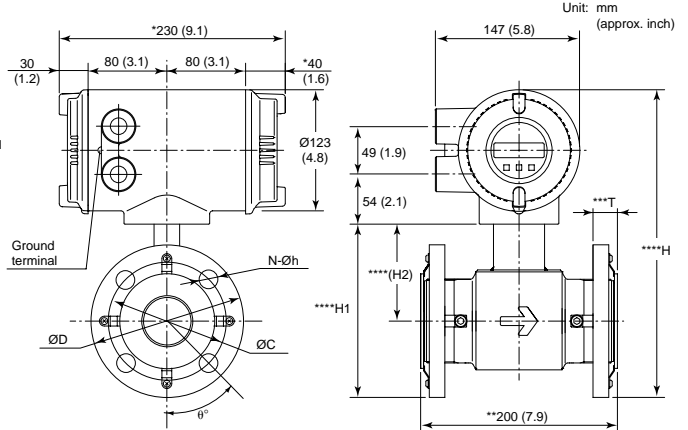

* The length marked as * is shorter by approx. 10mm(0.4 in.) for non indicator type.
** The face-to-face length is longer by approx. 22mm(0.87 in.) for earth ring P, T.
*** The thickness (T) is longer by approx. 11mm(0.43 in.) for earth ring P, T.
**** The face-to-face length is shorter by approx. 6mm(0.24 in.) for non earth ring type.
***** The thickness (T) is shorter by approx. 3mm(0.12 in.) for non earth ring type.
***** The face-to-face length is longer by approx. 2mm(0.08 in.) for optional code /FRG.
***** The thickness (T) is longer by approx. 1mm(0.04 in.) for optional code /FRG.
***** The height is shorter by approx. 2mm(0.08 in.) for ex-proof type.

		MG J AE115MN-AA SC D				
Type	General (MG), Ex-proof (MN/SC)					
Size code	115					
Size	15 (0.5)					
Lining	A (PFA)					
Process connection	J1	J2	A1	A2	D2	D4
Height	****H	267.5 (10.5)				
Height	****H1	127.5 (5.0)				
Outer diameter	D	95 (3.7)	95 (3.7)	88.9 (3.5)	95.3 (3.8)	95 (3.7)
Thickness	***T	19 to 24 (0.7 to 0.9)	21 to 26 (0.8 to 1.0)	18 to 25 (0.7 to 1.0)	21 to 28 (0.8 to 1.1)	20 to 26 (0.8 to 1.0)
Pitch circle dia.	C	70 (2.8)	70 (2.8)	60.5 (2.4)	66.5 (2.6)	65 (2.6)
Dia. of hole	h	15 (0.6)	15 (0.6)	15.7 (0.6)	15.7 (0.6)	14 (0.6)
Weight kg (lb)		6.3 (13.9)	6.5 (14.3)	6.1 (13.4)	6.5 (14.3)	6.5 (14.3)

Process connection : J1:JIS10K J2:JIS20K A1:ANSI 150 A2:ANSI 300 D2:DIN PN16
D4:DIN PN40

		202 MG J AE 204 MN-AA 205 SC D										
Size code	General (MG), Ex-proof (MN/SC)											
Size	202				204				205			
Size	25(1.0)				40(1.5)				50(2.0)			
Lining	A(PFA), U(Polyurethane)				A(PFA), U(Polyurethane)				A(PFA), U(Polyurethane)			
Process connection	J1	J2	A1	A2	D2	D4	J1	J2	A1	A2	D2	D4
Height	****H	76.8(3.0)										
Height	****H1	87(3.4)										
Height	****H2	94(3.7)										
Outer diameter	D	125 (4.9)	125 (4.9)	108 (4.3)	124 (4.9)	115 (4.5)	115 (4.5)	140 (5.5)	140 (5.5)	127 (5.0)	150 (5.9)	150 (5.9)
Thickness	***T	21(0.8) to 26(1.0)	23(0.9) to 28(1.1)	21(0.8) to 25(1.0)	22(0.9) to 28(1.1)	24(0.9) to 30(1.2)	23(0.9) to 28(1.1)	25(1.0) to 30(1.2)	25(1.0) to 31(1.2)	22(0.9) to 28(1.1)	24(0.9) to 30(1.2)	25(1.0) to 31(1.2)
Pitch circle dia.	C	90 (3.5)	90 (3.5)	79.2 (3.1)	88.9 (3.5)	85 (3.3)	85 (3.3)	105 (4.1)	105 (4.1)	88.6 (3.5)	114.3 (4.5)	110 (4.3)
Dia. of hole	h	19 (0.7)	19 (0.7)	15.7 (0.6)	19.1 (0.8)	14 (0.6)	14 (0.6)	19 (0.7)	19 (0.7)	15.7 (0.6)	22.4 (0.9)	18 (0.7)
Number of holes	N	4	4	4	4	4	4	4	4	4	4	4
Weight kg (lb)		7.5 (16.5)	7.8 (17.2)	6.9 (15.2)	7.5 (17.4)	7.4 (16.3)	7.4 (16.3)	9.7 (21.4)	10.0 (22.0)	9.3 (20.5)	10.3 (22.7)	10.3 (22.7)

Process Connection: J1:JIS10K J2:JIS20K A1:ANSI 150 A2:ANSI 300 D2:DIN PN16 D4:DIN PN40

80 and 100mm(3 and 4in.) Flange Type

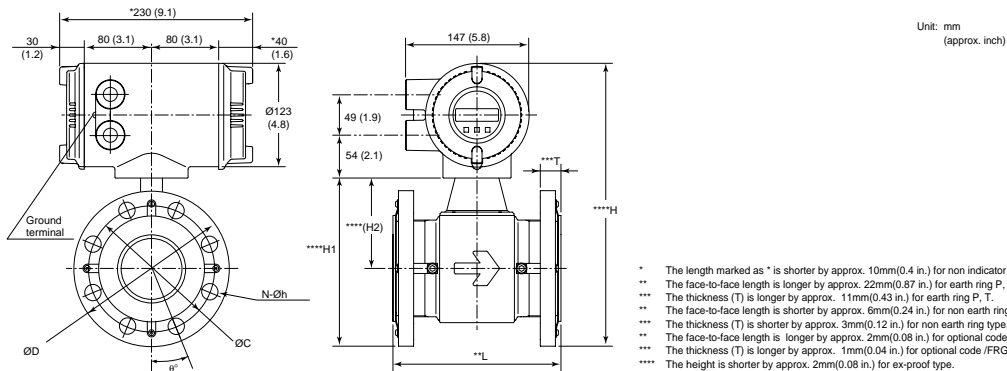

- * The length marked as * is shorter by approx. 10mm(0.4 in.) for non indicator type.
- ** The face-to-face length is longer by approx. 22mm(0.87 in.) for earth ring P. T.
- *** The thickness (T) is longer by approx. 11mm(0.43 in.) for earth ring P. T.
- **** The face-to-face length is shorter by approx. 6mm(0.24 in.) for non earth ring type.
- ***** The thickness (T) is shorter by approx. 3mm(0.12 in.) for non earth ring type.
- ***** The face-to-face length is longer by approx. 2mm(0.08 in.) for optional code /FRG.
- ***** The thickness (T) is longer by approx. 1mm(0.04 in.) for optional code /FRG.
- ***** The height is shorter by approx. 2mm(0.08 in.) for ex-proof type.

Size code	208						210						
	80(3.0)						100(4.0)						
Size	80(3.0)						100(4.0)						
Lining	A(PFA), U(Polyurethane)						A(PFA), U(Polyurethane)						
Process connection	J1	J2	A1	A2	D2	G1	J1	J2	A1	A2	D2	G1	
Height	341.5 (13.4)	349 (13.7)	344.3 (13.6)	353.8 (13.9)	349 (13.7)	354.5 (14.0)	377 (14.8)	384.5 (15.1)	386.3 (15.2)	399 (15.7)	382 (15.0)	391 (15.4)	
Height	201.5 (7.9)	209 (8.2)	204.3 (8.0)	213.8 (8.4)	209 (8.2)	214.5 (8.4)	237 (9.3)	244.5 (9.6)	246.3 (9.7)	259 (10.2)	242 (9.5)	251 (9.9)	
Height	109(4.3)						132(5.2)						
Outer diameter	D	185 (7.3)	200 (7.9)	190.5 (7.5)	209.6 (8.3)	200 (7.9)	211 (8.3)	210 (8.3)	225 (8.9)	228.6 (9.0)	254 (10.0)	220 (8.7)	238 (9.4)
Thickness	***T	25(1.0) to 31(1.2)	29(1.1) to 35(1.4)	31(1.2) to 38(1.5)	36(1.4) to 43(1.7)	26(1.0) to 32(1.3)	25(1.0) to 31(1.5)	25(1.0) to 31(1.5)	31(1.2) to 38(1.5)	31(1.2) to 38(1.5)	39(1.5) to 46(1.8)	26(1.0) to 32(1.3)	25(1.0) to 32(1.3)
Pitch circle dia.	C	150 (5.9)	160 (6.3)	152.4 (6.0)	168.1 (6.6)	160 (6.3)	168 (6.6)	175 (6.9)	185 (7.3)	190.5 (7.5)	200.2 (7.9)	180 (7.1)	195 (7.7)
Bolt hole pitch	φ ^o	22.5	22.5	45	22.5	22.5	45	22.5	22.5	22.5	22.5	22.5	45
Dia. of hole	h	19 (0.7)	23 (0.9)	19.1 (0.7)	22.4 (0.9)	18 (0.7)	19 (0.7)	19 (0.7)	23 (0.9)	19.1 (0.7)	22.4 (0.9)	18 (0.7)	19 (0.7)
Number of holes	N	8	8	4	8	8	4	8	8	8	8	8	4
Face-to-face length	**L	200(7.9)						250(9.8)					
Weight kg (lb)		15.3 (33.7)	17.3 (38.1)	17.6 (38.8)	20.6 (45.4)	17.3 (38.1)	17.8 (39.2)	23.3 (51.3)	26.5 (58.4)	27.3 (60.1)	34.7 (76.4)	25.0 (55.1)	26.4 (58.1)

F11.EPS

Process Connection : J1; JIS10K J2; JIS20K A1; ANSI 150 A2; ANSI 300 D2; DIN PN16 G1; JIS F12

150 and 200mm(6 and 8in.) Flange Type

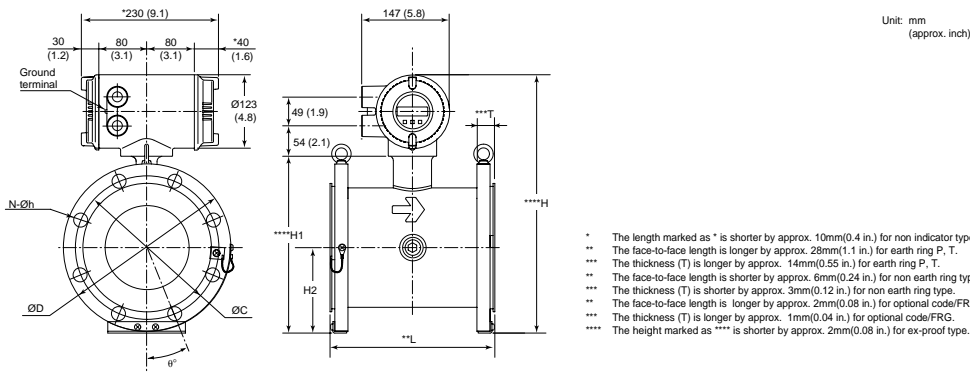

- * The length marked as * is shorter by approx. 10mm(0.4 in.) for non indicator type.
- ** The face-to-face length is longer by approx. 28mm(1.1 in.) for earth ring P. T.
- *** The thickness (T) is longer by approx. 14mm(0.55 in.) for earth ring P. T.
- **** The face-to-face length is shorter by approx. 6mm(0.24 in.) for non earth ring type.
- ***** The thickness (T) is shorter by approx. 3mm(0.12 in.) for non earth ring type.
- ***** The face-to-face length is longer by approx. 2mm(0.08 in.) for optional code /FRG.
- ***** The thickness (T) is longer by approx. 1mm(0.04 in.) for optional code /FRG.
- ***** The height marked as ***** is shorter by approx. 2mm(0.08 in.) for ex-proof type.

Size code	215								220							
	150(6.0)								200(8.0)							
Size	150(6.0)								200(8.0)							
Lining	A (PFA), U (Polyurethane)								A (PFA), U (Polyurethane)							
Process connection	J1	G1	A1	J2	A2	D1	D2	J1	G1	A1	J2	A2	D1	D2		
Face-to-face length	270(10.6)								340(13.4)							
Outer diameter	D	280 (11.0)	290 (11.4)	280 (11.0)	305 (12.0)	320 (12.6)	285 (11.2)	285 (11.2)	330 (13.0)	342 (13.5)	345 (13.6)	350 (13.8)	380 (15.0)	340 (13.4)	340 (13.4)	
Height	****H	435 (17.1)	440.5 (17.3)	245.5 (9.7)	448.5 (17.7)	455.5 (17.9)	438.5 (17.3)	438.5 (17.3)	485 (19.1)	491.5 (19.4)	491.5 (19.4)	495.5 (19.5)	508.5 (20.0)	488.5 (19.2)	488.5 (19.2)	
Height	****H1	295 (11.6)	300.5 (11.8)	295.5 (11.6)	308.5 (12.1)	315.5 (12.4)	298.5 (11.8)	298.5 (11.8)	345 (13.6)	351.5 (13.8)	351.5 (13.8)	355.5 (14.0)	368.5 (14.5)	348.5 (13.7)	348.5 (13.7)	
Height	H2	143 (5.6)	148 (5.8)	143 (5.6)	156 (6.1)	163 (6.4)	146 (5.7)	146 (5.7)	168 (6.6)	174 (6.9)	176 (7.0)	178 (7.0)	193 (7.6)	173 (6.8)	173 (6.8)	
Pitch circle dia.	C	240 (9.4)	247 (9.7)	241 (9.5)	260 (10.2)	270 (10.6)	240 (9.4)	240 (9.4)	290 (11.4)	299 (11.8)	298 (11.7)	305 (12.0)	330 (13.0)	295 (11.6)	295 (11.6)	
Bolt hole pitch	φ ^o	22.5	30	22.5	15	15	22.5	22.5	15	22.5	22.5	15	15	22.5	15	
Number of holes	N	8	6	8	12	12	8	8	12	8	8	12	12	8	12	
Dia. of hole	h	23 (0.9)	19 (0.7)	23 (0.9)	25 (1.0)	22 (0.9)	22 (0.9)	22 (0.9)	23 (0.9)	19 (0.7)	23 (0.9)	25 (1.0)	25 (1.0)	22 (0.9)	22 (0.9)	
Thickness (PFA)	***T	30	30	33.4	36	44.5	30	30	30	32	36.4	38	49.1	32	32	
Thickness (Polyurethane)	***T	31	31	34.4	37	45.5	31	31	31	33	37.4	39	50.1	33	33	
Weight kg (lb)	(General)	31.3 (68.9)	33.3 (73.3)	33.3 (73.3)	39.3 (86.6)	50.3 (110.8)	32.3 (71.1)	33.3 (73.3)	43.3 (95.4)	48.3 (106.4)	51.3 (113.0)	54.3 (120.0)	75.3 (165.9)	47.3 (104.2)	48.3 (106.4)	
Weight kg (lb)	(Ex-proof)	34.3 (75.6)	36.3 (80.0)	36.3 (80.0)	42.3 (93.2)	53.3 (117.4)	35.3 (77.8)	36.3 (80.0)	48.3 (106.4)	53.3 (117.4)	56.3 (124.0)	59.3 (130.6)	80.3 (176.9)	52.3 (115.2)	53.3 (117.4)	

Process connection : J1; JIS10K J2; JIS20K A1; ANSI 150 A2; ANSI 300 D1; DIN PN10 D2; DIN PN16 G1; JIS F12

F12.EPS

250 to 400mm(10 to 16in.) Flange Type

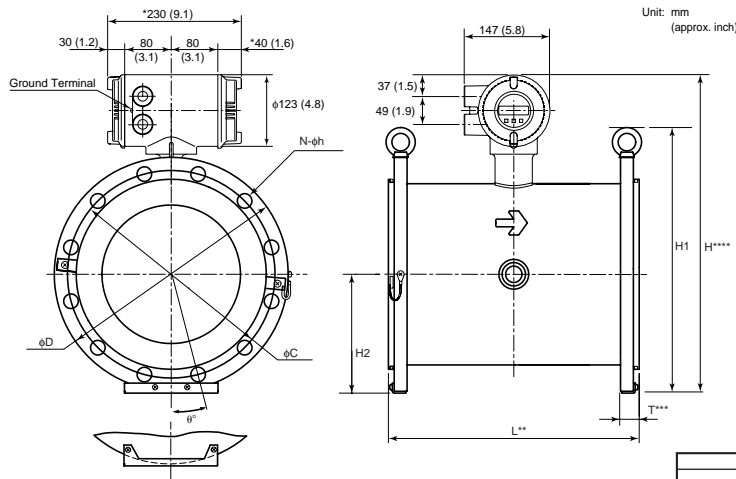

* The length marked as * is shorter by approx. 10mm (0.4 in.) for non indicator type.

Lining code A : PFA lining U : Polyurethane lining
 ** The face-to-face length is shorter by approx. 6mm(0.24 in.) for non earth ring type of AE325 and AE330, by approx. 10mm(0.39 in.) for non earth ring type of AE335 and AE340.
 *** The thickness(T) is shorter by approx. 3mm(0.12 in.) for non earth ring type of AE325 and AE330, by approx. 5mm(0.20 in.) for non earth ring type of AE335 and AE340.
 **** The height(H) is shorter by approx. 2mm(0.08 in.) for ex-proof type.

325 J
 330MG AG
 AE 335MN UA
 340 D

for AE330,AE335,AE340

Type	General(G), Ex-proof(N)			
	325	330	335	340
Size code	325	330	335	340
Size	250(10)	300(12)	350(14)	400(16)
Lining code	A(PFA) U(Polyurethane)			
Face-to-face	L**	430(16.9)	500(19.7)	550(21.7)
Eye bolt hole dia.	e	30(1.2)	30(1.2)	35(1.4)
Height	H****	550(21.7)	597(23.5)	640(25.2)
	H1	454(17.9)	499(19.7)	553(21.8)
Outer dia.	øD	400(15.8)	445(17.5)	490(19.3)
	øC	355(14.0)	400(15.8)	445(17.5)
Pitch circle dia.	øD	400(15.8)	445(17.5)	490(19.3)
	øC	355(14.0)	400(15.8)	445(17.5)
Number of holes	N	12	16	16
	ø	15	11.25	11.25
Hole dia.	øh	25(1.0)	25(1.0)	27(1.1)
	ø	25(1.0)	25(1.0)	27(1.1)
Thickness(A)	T***	32(1.3)	34(1.3)	36(1.4)
	T***	33(1.3)	35(1.4)	37(1.4)
Thickness(U)	T***	33(1.3)	35(1.4)	37(1.5)
	T***	33(1.3)	35(1.4)	37(1.5)
Weight (General) kg(lb)		66.3(146.2)	83.3(183.6)	96.3(212.3)
		70.3(155.0)	87.3(192.5)	102.3(225.5)
Weight (Ex-proof) kg(lb)		66.3(146.2)	83.3(183.6)	96.3(212.3)
		70.3(155.0)	87.3(192.5)	102.3(225.5)

Type	General(G), Ex-proof(N)			
	325	330	335	340
Size code	325	330	335	340
Size	250(10)	300(12)	350(14)	400(16)
Lining code	A(PFA) U(Polyurethane)			
Face-to-face	L**	430(16.9)	500(19.7)	550(21.7)
Eye bolt hole dia.	e	30(1.2)	30(1.2)	35(1.4)
Height	H****	553(21.8)	616(24.3)	662(26.1)
	H1	461(18.1)	537(21.1)	597(23.5)
Outer dia.	øD	406(16.0)	453(19.0)	533(21.0)
	øC	362(14.3)	432(17.0)	476(18.7)
Pitch circle dia.	øD	406(16.0)	453(19.0)	533(21.0)
	øC	362(14.3)	432(17.0)	476(18.7)
Number of holes	N	12	12	16
	ø	15	15	11.25
Hole dia.	øh	26(1.0)	26(1.0)	29(1.1)
	ø	26(1.0)	26(1.0)	29(1.1)
Thickness(A)	T***	38(1.5)	40(1.6)	45(1.8)
	T***	39(1.5)	41(1.6)	46(1.8)
Thickness(U)	T***	39(1.5)	41(1.6)	46(1.8)
	T***	39(1.5)	41(1.6)	46(1.8)
Weight (General) kg(lb)		72.3(159.4)	92.3(203.5)	112.3(247.6)
		76.3(168.2)	96.3(212.3)	118.3(260.8)
Weight (Ex-proof) kg(lb)		72.3(159.4)	92.3(203.5)	112.3(247.6)
		76.3(168.2)	96.3(212.3)	118.3(260.8)

Sanitary, Integral Magnetic Flowmeter AE200MH

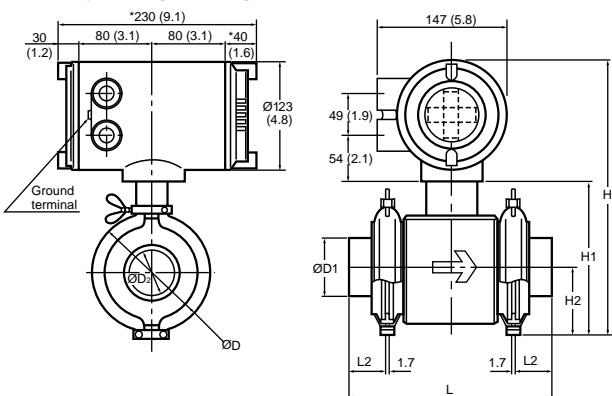

202
 204
 AE 205
 206 MH
 208
 210

Size code	202	204	205	206	208	210
Size	25(1)	40(1.5)	50(2)	65(2.5)	80(3)	100(4)
Lining	PFA					
Face-to-face length	L	176(6.9)	186(7.3)	206(8.1)	246(9.7)	272(10.7)
Ferrule length	L2	43(1.7)	41(1.6)	44(1.7)	44(1.7)	44(1.7)
Ferrule outer diameter	D1	25(1.0)	38(1.5)	51(2.0)	64(2.5)	76(3.0)
Ferrule inner diameter	D2	23(0.9)	36(1.4)	48(1.9)	60(2.4)	72(2.8)
Clamp O.D.	D	74(2.9)	89.5(3.5)	103(4.1)	122(4.8)	131(5.2)
Height	H	266(10.5)	289(11.4)	301(11.9)	314(12.4)	340(13.4)
Height	H1	126(5.0)	149(5.8)	161(6.3)	174(6.9)	200(7.9)
Height	H2	49(1.9)	61(2.4)	67(2.6)	70(2.8)	81(3.2)
Weight kg (lb)		5.8(12.8)	6.9(15.2)	8.3(18.3)	9.9(21.8)	12.2(26.9)

F13.EPS

11. PARAMETER SUMMARY

This chapter describes all parameters used by ADMAG AE.

- Description of Items

No.		Name	Data Range, Units		Deci- mal Point	Initial Setting	R/W	Description
AE	BT		AE	BT				

Description

- Parameter number on the ADMAG AE display panel
- Parameter number on BT display
- Parameter name on BT display
- "00 - 20" are the numbers that can be set on the ADMAG AE. The desired number can be entered when "S" is displayed.
- Indicates the range of allowable settings and the units used. 8 alphanumeric characters can be entered when "8 ASCII characters" is specified.
- Numbers indicate the position of decimal point and its range of movement within the data display.
ADMAG AE display panel :
8 8 : ₄8₃8₂8₁8₀
Example :
0 to 4 : Can be moved in the range 0 to 4
4 : Fixed at 4
- Indicate initially set value (When shipped from the factory)
- R : Display only W : Write enabled
- Describes the nature of the parameter

11. PARAMETER SUMMARY

No.		Name	Data Range, Units		Deci- mal Point	Initial Setting	R/W	Description
AE	BT		AE	BT				
—	A00	DISPLAY					R	Major display items
—	A10	FLOW RATE(%)	—	- 8.0(-108.0) to 108.0%	1		R	Displays instantaneous flow in %
—	A20	FLOW RATE	—	±300.0m/s	0 to 4		R	Displays instantaneous flow in actual units
—	A30	TOTAL	—	0 to 999999	0		W	Displays forward direction totalization values
	A60	SELF CHECK	—	GOOD ERROR µP FAULT EEPROM FAULT A/D (L) FAULT A/D (H) FAULT SIGNAL OVERFLOW COIL OPEN SPAN VEL.>10m/s SPAN VEL.<0.3m/s P. SPAN>1000p/s P. SPAN>500p/s P. SPAN>25p/s P. SPAN>15p/s P. SPAN>10p/s P. SPAN>5p/s P. SPAN<0.0001p/s T. SPAN>1000p/s T. SPAN<0.0001p/s 4 · 20 LMT ERROR EMPTY PIPE MULTI RANGE EROOR			R	Self check Indicates nature of alarm when alarm occurs.

11. PARAMETER SUMMARY

No.		Name	Data Range, Units		Deci- mal Point	Initial Setting	R/W	Description
AE	BT		AE	BT				
—	B00	SET	—				R	Major parameter setting items
—	B01	TAG NO.	—	8 ASC II characters		(Space)	W	Specifies tag number using up to 8 characters.
02	B02	DAMPING	S	0.1 to 200.0	1	3.0	W	Sets output time constants.
03	B03	FLOW SPAN	S	1 to 30000	0 to 4	1.0000	W	Flow rate span A combination of B04 and B05 units are used.
04	B04	FLOW UNIT	00 01 02 03 04 05 06 07 08 09 10 11 12 13	km ³ (10 ³ X m ³) m ³ l (liter) cm ³ (10 ⁻² X m) ³ Mgal kgal gal mgal kbbbl bbbl mbbl ubbl m ft		m	W	Select volume units of flow rate span.
05	B05	TIME UNIT	00 01 02 03	/d /h /m /s		/s	W	Select time constants of flow rate span.
06	B06	SIZE UNIT	00 01	mm inch		mm	W	Sets unit of meter tube size
07	B07	NOMINAL SIZE	S	1 to 3000.0	1	(Set)	W	Sets meter tube size using B06 units.
08	B08	LOW MF		0.2500 to 3.0000	4	(Set)	W	Select low frequency measurement meter factor.
09	B09	HIGH MF		0.2500 to 3.0000	4	(Set)	W	Select high frequency measurement meter factor.
10	B10	OUTPUT FUNC	00 01 02 03 04 05	PULSE OUT ALARM OUT BI DIRECTION AUTO 2 RANGES LOW ALARM TOTAL SWITCH		PULSE OUT	W	Select pulse output / alarm output or status output functions.
11	B11	4 - 20 ALM OUT	00 01 02 03	2.4mA OR LESS 4.0mA HOLD 21.6mA OR MORE		2.4mA OR LESS	W	Select current to be output during alarm. However, a hardware failure that causes a burn-out will result in 0 mA output.

11. PARAMETER SUMMARY

No.		Name	Data Range, Units		Deci- mal Point	Initial Setting	R/W	Description
AE	BT		AE	BT				
12	B12	POWER FREQ	S	47.00 to 63.00	2	50.00	W	Power frequency setting
13	B13	VELOCITY CHK	S	0 to 20.000	3		R	Range span displayed in m/s
14	B14	FLOW DIR	00 01	FORWARD REVERSE		FOR WARD	W	Select flow direction
30	B30	REV. SPAN	S	1 to 30000	0 to 4	1.0000	W	Span for reverse direction flow measuring
31	B31	BI. DIREC HYS	S	0 to 10	0	2	W	Direct / reverse flow measuring hysteresis
33	B33	FOR. SPAN 2	S	1 to 30000	0 to 4	1.0000	W	Second span for forward direction multi - range
34	B34	AUTO RNG HYS	S	0 to 15	0	10	W	Two range transfer hysteresis
36	B36	LOW ALARM	S	-10 to 110	0	-10	W	Comparison level for alarm output at low flow limits
37	B37	L. ALARM HYS	S	0 to 10	0	5	W	Hysteresis for alarm output at low flow limits
—	B60	SELF CHECK	00 ↓ 21	GOOD ↓ MULTI RANGE ERROR			R	Self check Indicates nature of alarm when alarm occurs.
—	C00	ADJUST	—				R	Parameter for setting auto zero adjust
C1	C01	ZERO TUNING	00 01	INHIBIT ENABLE		ENABLE	W	Parameter for setting auto zero adjust
C2	C02	MAGFLOW ZERO	S	0 to -99.99	2	0.00	W	Displays zero correction
—	C60	SELF CHECK	00 ↓ 21	GOOD ↓ MULTI RANGE ERROR			R	Self check Indicates nature of alarm when alarm occurs.

11. PARAMETER SUMMARY

No.		Name	Data Range, Units		Deci- mal Point	Initial Setting	R/W	Description
AE	BT		AE	BT				
—	D00	DISP SEL	—				R	Display selection items
d1	D01	DISP SELECT	00	RATE (%)		RATE(%)	W	Display panel selections
			01	RATE				
			02	FOR. TOTAL				
			03	REV. TOTAL				
			04	DIF. TOTAL				
			05	RATE(%) / FOR. TTL				
			06	RATE / FOR. TTL				
			07	RATE / RATE(%)				
			08	RATE(%) / REV. TTL				
			09	RATE / REV. TTL				
			10	RATE(%) / DIF. TTL				
			11	RATE / DIF. TTL				
d2	D02	FL USER SEL	00	NOT PROVIDED		NOT PROVIDED	W	Selects whether special units are to be used for instantaneous flow rates
			01	PROVIDED				
d3	D03	FL USER SPAN	S	0 to 30000	0 to 4	100	W	Sets the value to be displayed in the special unit at 100% output
—	D10	FL USER UNIT	—	8 ASCII characters		Space	W	Sets the special instantaneous flow rate unit
—	D60	SELF CHECK	00	GOOD			R	Self check
			↓	↓				Indicates nature of alarm when alarm occurs
			21	MULTI RANGE ERROR				
—	E00	TOTAL SET	—				R	Totalization display items
E1	E01	TOTAL UNIT	00	n UNIT / P		PULSE/S	W	Sets flow rate unit per pulse for totalization display
			01	μ UNIT / P				
			02	m UNIT / P				
			03	UNIT / P				
			04	k UNIT / P				
			05	M UNIT / P				
			06	PULSE / S				
E2	E02	TOTAL SCALE	S	0 to 30000	0 to 4	0	W	Sets flow rate per pulse for totalization display
E3	E03	TOTAL LOWCUT	S	0 to 100	0	3	W	Sets the range in vicinity of 0% within which totalization will be halted
E4	E04	TOTAL SET	00	INHIBIT		INHIBIT	W	Totalization preset(reset) enabled / inhibited
			01	ENABLE				
E5	E05	TL SET VALUE	S	0 to 999999	0	0	W	Sets preset (reset) value

11. PARAMETER SUMMARY

No.		Name	Data Range, Units		Decimal Point	Initial Setting	R/W	Description
AE	BT		AE	BT				
E6	E06	TOTAL SWITCH	S	0 to 999999	0	0	W	Set the totalization switch level
—	E10	TL USER UNIT	S	8 ASCII characters		Space	W	Sets special totalization units
—	E11	REV. TOTAL	—	0 to 999999	0	0	R	Display differential totalization values
—	E12	DIF. TOTAL	—	0 to 999999	0	0	R	Display differential totalization values
	E60	SELF CHECK	00 ↓ 21	GOOD ↓ MULTI RANGE ERROR			R	Self check Indicates ature of alarm when alarm occurs.
—	F00	PULSE SET	—				R	Pulse output items
F1	F01	PULSE UNIT	00 01 02 03 04 05 06	n UNIT / P μ UNIT / P m UNIT / P UNIT / P k UNIT / P M UNIT / P PULSE / S		PULSE/S	W	Selects pulse rate units
F2	F02	PULSE SCALE	S	0 to 30000	0 to 4	0	W	Sets pulse rate
F3	F03	PULSE LOWCUT	S	0 to 100	0	3	W	Sets the range in vicinity of 0% within which pulse output will be halted
F4	F04	PULSE WIDTH	00 01 02 03 04 05 06	50% DUTY 0.5 msec 1 msec 20 msec 33 msec 50 msec 100 msec		50% DUTY	W	Sets width of pulse output
—	F60	SELF CHECK	00 ↓ 21	GOOD ↓ MULTI RANGE ERROR			R	Self check Indicates nature of alarm when alarm occurs

11. PARAMETER SUMMARY

No.		Name	Data Range, Units		Decimal Point	Initial Setting	R/W	Description
AE	BT		AE	BT				
—	G00	4 - 20 SEL	—				R	Current output (4 to 20) settings
G1	G01	4 - 20 LOW CUT	S	0 to 10	0	0	W	Sets low cut range for 4 to 20 mA output
G2	G02	4 - 20 LOW LMT	S	-20 to 100	0	-20	W	Sets low limit for 4 to 20 mA output
G3	G03	4-20 H LMT	S	0 to 120	0	120	W	Sets high limit for 4 to 20 mA output
—	G60	SELF CHECK	00 ↓ 21	GOOD ↓ MULTI RANGE ERROR			R	Self check Indicates nature of alarm when alarm occurs
—	H00	TEST	—				R	Test mode items
H1	H01	TEST MODE	00 01	NORMAL TEST		NORMAL	W	Sets normal mode/test mode
H2	H02	OUTPUT VALUE	S	-8(-108) to 108	0	0	W	Sets test output values
H3	H03	ALARM OUT	00 01 02	NORMAL CLOSED(ON) OPEN(OFF)		NORMAL	W	Sets state of alarm output
—	H60	SELF CHECK	00 ↓ 21	GOOD ↓ MULTI RANGE ERROR			R	Self check Indicates nature of alarm when alarm occurs
—	L00	OTHER					R	Data change inhibit/enable and display restrictions
L1	L01	TUNING	00 01	INHIBIT ENABLE		ENABLE	W	Select whether data changes should be inhibit or enabled
L2	L02	KEY	00 55	00(TO"L") 55(TO"N")		0	W	Display restrictions Set 55 and items up to N will be displayed
—	L60	SELF CHECK	00 ↓ 21	GOOD ↓ MULTI RANGE ERROR			R	Self check Indicates nature of alarm when alarm occurs

11. PARAMETER SUMMARY

No.		Name	Data Range, Units		Decimal Point	Initial Setting	R/W	Description
AE	BT		AE	BT				
—	N00	APPL SET	—				R	
n1	N01	TOTAL / PULSE	00 01	NO DAMP DAMP		DAMP	W	Select whether instantaneous flow rate values or damping derived flow rate values are to be used in totalization / pulse
n2	N02	PLSE MODE	00 01	ON OFF		ON	W	Select whether the pulse output transistor is to be set to ON ACTIVE or OFF ACTIVE
n3	N03	RATE LIMIT	S	0 to 10	0	0 to 5	W	Sets the level to reduce output fluctuation.
n4	N04	DEAD TIME	S	0 to 15	0	0	W	Sets the dead time to reduce output fluctuation. When "0" is set, "Rate limit" is not available.
n5	N05	POWER SYNCH	00 01	YES NO		YES	W	Select whether the internal frequency is to be synchronized with the power supply or not.
n6	N06	PULSING FLOW	00 01	YES NO		NO	W	Counteraction of pulseing flow
n7	N07	EMPTY PIPE	00 01	ALARM NO ALARM		ALARM	W	Select whether the detecting empty pipe function is to be used as an alarm or not.
—	N60	SELF CHECK	00 ↓ 21	GOOD ↓ MULTI RANGE ERROR			R	Self check Indicates nature of alarm when alarm occurs

12. EXPLOSION PROTECTED TYPE INSTRUMENT

In this section, further requirements and differences for explosion proof type instrument are described. For explosion proof type instrument, the description in this chapter is prior to other description in this User's Manual.



CAUTION

The terminal box cover and display cover is locked by special screw. In case of opening the cover, please use the Hexagonal Wrench attached.



CAUTION

Be sure to lock the cover with the special screw using the Hexagonal Wrench attached after tightening the cover.

12.1 CENELEC ATEX (KEMA)



WARNING

Only trained persons use this instrument in industrial locations.

(1) Technical Data

No. KEMA 02ATEX2022

Group category : II 2G

EEx dme[ia]IIC T6...T3

Electrode Circuit U_m : 250V ac/dc

Excitation Circuit : 130V_{peak max.} 72/75Hz,
0.2A max.

Temp. Class. T6 T5 T4 T3

Max Process Temp. +70 +85 +120
+130°C

Enclosure : IP67

(2) Electrical Connection

The type of electrical connection is stamped near the electrical connection port according to the following codes.

Screw Size	Marking
ISO M20x1.5 female	△ M
ANSI 1/2NPT female	△ A

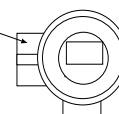

(3) Installation



WARNING

- All wiring shall comply with local installation requirements and local electrical code.
- In hazardous locations, the cable entry devices shall be of a certified flameproof type, suitable for the conditions of use and correctly installed.
- Unused apertures shall be closed with suitable flameproof certified blanking elements. (The plug attached is flameproof certified.)

(4) Operation



WARNING

- Wait 10 min. after power is turned off, before opening the covers.
- Take care not to generate mechanical spark when access to the instrument and peripheral devices in hazardous locations.

(5) Maintenance and Repair



WARNING

The instrument modification or parts replacement by other than authorized representative of Yokogawa Electric Corporation is prohibited and will void the certification.

(6) Data Plate

ADMAGAE MAGNETIC FLOWMETER		IM: User's Manual	
MODEL SUFFIX		PULSE OUTPUT	30VDC 0.2Amax.
STYLE		LINING MATERIAL	
SIZE	m	ELECTRODE MATERIAL	
METER FACTOR	L H	ACCURACY RATING	(JIS B7554) <small>(SEE THE NOTES AT THE END AND SEE IM)</small>
SUPPLY	V DC \pm 12.5	FLUID TEMP.	
	VAC - 47-63 Hz 36 VA 12.5	FLUID PRESS	-0.1 MPa MIN. (SEE IM)
FULLSCALE		Tamb.	+60°C MAX. (SEE IM)
CURRENT OUTPUT	4-20mA (0-750 Ω)	No.	
CE 0344 I2G No.: KEMA 02ATEX2022 EEx dme[ia]IIC T6...T3 TEMP.CLASS: T6 T5 T4 T3 MAX.PROCESS TEMP.(°C): +70 +85 +120 +130 ELECTRODE CIRCUIT Um: 250V ac/dc ENCLOSURE: IP67 YOKOGAWA \blacklozenge Made in Japan TOKYO 180-8750 JAPAN		WARNING AFTER DE-ENERGIZING, DELAY 10 MINUTES BEFORE OPENING.	

MODEL : Specified model code
 SUFFIX : Suffix codes of the model code
 STYLE : Specified style code
 SIZE : Nominal size of apparatus
 METER FACTOR : Sensor constant number of apparatus
 SUPPLY : Power supply voltage of apparatus
 FULL SCALE : Meter range
 CURRENT OUTPUT : Output signal of apparatus
 PULSE OUTPUT : Output signal of apparatus
 LINING MATERIAL : Material of liner
 ELECTRODE MATERIAL : Material of electrodes
 ACCURACY RATING : Accuracy of apparatus
 FLUIDTEMP. : Fluid temperature of apparatus
 FLUIDPRESS : Fluid pressure of apparatus
 Tamb : Ambient temperature
 No. : Manufacturing serial number
 CE : CE marking
 ExII 2G : Group II Category 2 Gas atmosphere
 KEMA No. : KEMA 02ATEX2022 : Certificate number
 EExdem[ia]IIC T6...T4 : Protection type and temp. class
 ELECTRODE CIRCUIT Um : Voltage of electrode circuit
 ENCLOSURE : Enclosure protection number
 IM : User's Manual

! WARNING: Warning to apparatus
 YOKOGAWA \blacklozenge TOKYO 180-8750 JAPAN :
 Name and address of manufacturer

*1) The third figure from the last shows the last one figure of the year of production. For example, the year of production of the product engraved as follows is year 1998.

No. F261GA091 813
 ↑
 Produced in 1998

*2) The identification number of the notified body :
 0344

*3) The product-producing country

12.2 FM

(1) Technical Data

- Explosionproof for Class I Division 1 Groups A, B, C & D. Dust-ignitionproof for Class II/III Division 1 Groups E, F & G. Intrinsically safe (electrode) for Class I Division 1 Groups A, B, C & D
 Electrode circuit Vmax : 250V ac/dc
 Temp. Class. T6

Enclosure : NEMA 4X

- Nonincendive for Class I, Division 2, Groups A, B, C & D ; Suitable for Class II, Division 2, Groups F & G ; Class III, Division 1 and 2
 Intrinsically safe (electrode) for Class I Division 1 Groups A, B, C & D
 Electrode Circuit Vmax : 250V ac/dc
 Excitation Circuit : 130Vp 72/75Hz
 Temp. Code : T5
 Enclosure : NEMA 4X

(2) Installation

! WARNING

- All wiring shall comply with national electrical code ANSI/NFPA 70 and local electrical code.
- In hazardous locations, wiring to be in conduit as shown in Figure 12.2.1.

(3) Operation

! WARNING

- Open circuit before opening the covers and seal all conduits with in 18 inches in hazardous locations.
- Take care not to generate mechanical spark when access to the instrument and peripheral devices in hazardous locations.

(4) Maintenance and Repair

! WARNING

The instrument modification or parts replacement by other than authorized representative of Yokogawa Electric Corporation is prohibited and will void the approval of Factory Mutual Research Corporation.

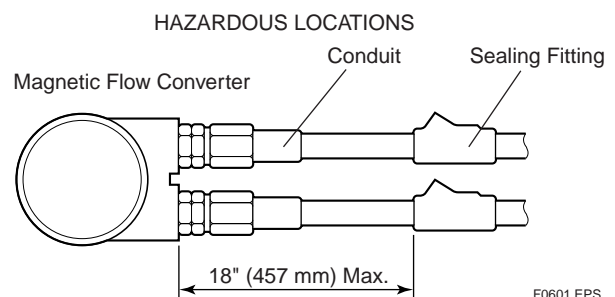

Figure 12.2.1 Conduit Wiring

12.3 CSA

(1) Technical Data

- Explosionproof for Class I, Groups B, C & D ; Class II, Groups E, F & G ; Class III
Electrode: Intrinsically safe for Class I, Division 1, Groups A, B, C & D
Electrode Circuit Vmax: 250V ac/dc
Temp. Code T6 T5 T4
Process Temp 70 85 120°C
Enclosure: Type 4
- Nonincendive for Class I, Division 2, Groups A, B, C & D ; Suitable for Class II, Division 2, Groups E, F and G ; Class III
Electrode: Intrinsically safe for Class I, Division 1, Groups A, B, C & D
Electrode Circuit Vmax: 250V ac/dc
Excitation Circuit: 130Vp 72/75Hz, 11VAmax
Temp. Code T5 T4
Process Temp 85 120°C
Enclosure: Type 4

(2) Installation



WARNING

All wiring shall comply with Canadian Electrical Code Part I and Local Electrical Codes. In hazardous location, wiring shall be in conduit as shown in Figure 12.3.1.

CAUTION : SEAL ALL CONDUITS WITHN 50cm OF THE ENCLOSURE' UN SCÉLLEMENT DOIT ÊTRE INSTALLÉ À MOINS DE 50cm DU BOÎTIER.

(3) Operation



WARNING

CAUTION : OPEN CIRCUIT BEFORE REMOVING COVER.

OUVRIER LE CIRCUIT AVANT D'ENLEVER LE COUVERCLE.

Take care not to generate mechanical spark when access to the instrument and peripheral devices in hazardous location.

(4) Maintenance and Repair



WARNING

The instrument modification or parts replacement by other than authorized representative of YOKOGAWA Electric Corporation or YOKOGAWA Corporation of AMERICA is prohibited and will void Canadian Standards Explosionproof Certification.

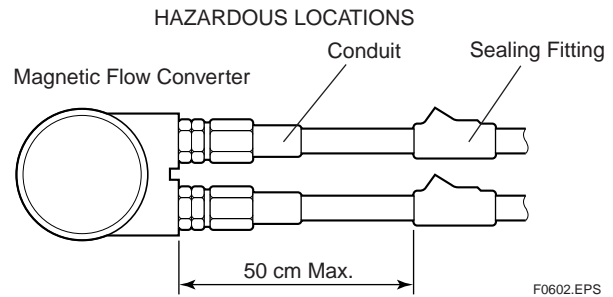

Figure 12.3.1 Conduit Wiring

12.4 SAA



WARNING

Only trained persons use this instrument in industrial locations .

(1) Technical Data

SA Certificate No.	AUS Ex 3210X
Type of Protection	Ex dm(ia)II C T6 IP67
Electrode Circuit Um	250V ac/dc
Excitation Circuit	130Vp 72/75Hz
Temperature Class	T6 T5 T4
Process Temperature	70 85 120°C

(2) Installation



WARNING

- All wiring shall comply with local installation requirements and local electrical code.
- In hazardous locations, the cable entry devices shall be of a certified flameproof type, suitable for the conditions of use and correctly installed.
- Unused apertures shall be closed with suitable flameproof certified blanking elements. (The plug attached is flameproof certified.)

(3) Operation**WARNING**

- Open circuit before opening the covers.
- Take care not to generate mechanical spark when access to the instrument and peripheral devices in hazardous locations.

(4) Maintenance and Repair**WARNING**

The instrument modification or parts replacement by other than authorized representative of Yokogawa Electric Corporation is prohibited and will void the certification.

12.5 JIS**WARNING**

Care should be taken to install, wiring, piping to keep safety. This instrument is restricted to maintenance and repair. Please read "INSTALLATION AND OPERATING PRECAUTIONS FOR JIS FLAMEPROOF EQUIPMENT" in the end of this manual.

(1) Technical Data

- **Construction :**
:Exde[ia]IICT4X
:Terminal box; Explosion proof
Flow Tube; Increased Safety
Signal Circuit; Intrinsically Safety(ia)
Um=250VAC 50/60Hz, 250VDC
*Uo and Io are **rms** value.
:Ignition and Explosion Class of gas or vapour;
IICT4X
- **Ambient Temperature : -20 to 60°C**
- **Fluid Temperature : 120°C or less**
- **Current Signal Circuit Allowable Voltage : 250V AC/DC**
- **Grounding : 10Ω or less**

**WARNING**

- In case the ambient temperature exceeds 50°C, use heat-resistant cables with maximum allowable temperature of 70°C or above.
- Maintenance and repair of the converter should be done in nonhazardous location after turning off.

(2) Wiring

Flameproof packing adapter is attached to electrical connection.

**WARNING**

Please use G11 or G12 (option) flameproof packing adapter attached.

Follow the procedure for flameproof packing adapter setting.

**CAUTION**

Before tightening, confirm cable length from terminal to flameproof packing adapter when setting. Once it is tightened, loosening and re-tightening may damage its sealing performance.

- Measure the bi-direction of the cable outside diameter to one decimal place in mm.
- Calculate the average of these values, and choose the suitable packing from attached two.[Refer to the figure 12.5.1.]
- Screw the M.screw into the electrical connection. (Ensure O-ring)
- Set union nut, B.coupling, clamp nut, clamp ring, packing gland, packing case with inserted packing and washer in that order around the cable, and tighten packing gland. And then tighten clamp nut. Confirm packing is compressed and cable is fixed.
- Insert packing gland into M.screw.
- Connect each wire of the cable to terminal.
- Tighten and fix union nut.
- Tighten and fix hexagon socket set screw of M.screw and union nut.

12. EXPLOSION PROTECTED TYPE INSTRUMENT

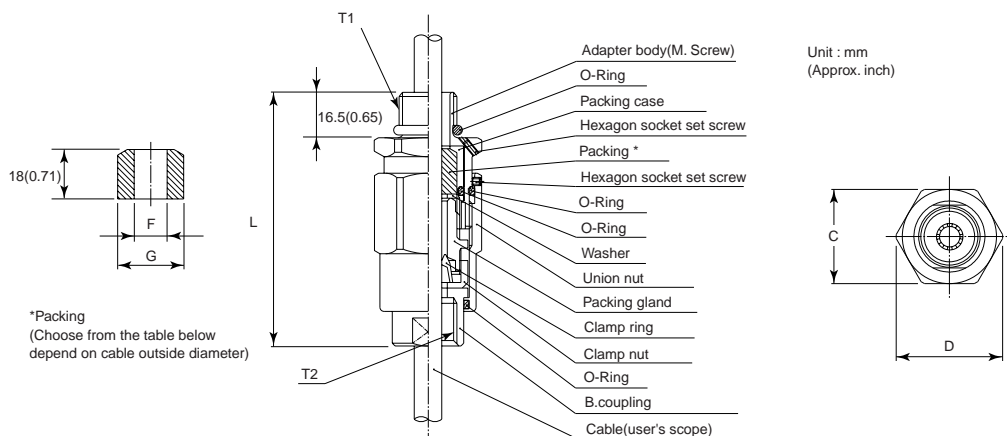

Dimension					Cable outer diameter	Packing diameter		Identification mark	Weight kg (lb)
T1	T2	C	D	L		F	G		
G 1/2	G 1/2	35 (1.38)	39 (1.54)	94.5 (3.72)	φ8.0 to φ10.0 (0.31 to 0.39)	φ10.0(0.39)	φ20.0 (0.79)	16 8-10	0.26 (0.57)
					φ10.0 to φ12.0 (0.39 to 0.47)	φ12.0(0.47)			

Figure 12.5.1 Flameproof Packing Adapter

13. PRESSURE EQUIPMENT DIRECTIVE

This chapter is described further requirements and notices concerning the PED (Pressure Equipment Directive). The description in this chapter is prior to other description in this User's Manual.

(1) Technical Data

Module : H

Type of Equipment : Piping

Type of Fluid : Liquid and Gas

Group of Fluid : 1 and 2

General Purpose / Explosion Proof

MODEL	DN (mm)*	PS (MPa)*	PS-DN (MPa-mm)	CATEGORY**
AE102MG/MN/SC	2.5	4	10	Article 3,*** paragraph 3
AE105MG/MN/SC	5	4	20	Article 3,*** paragraph 3
AE110MG/MN/SC	10	4	40	Article 3,*** paragraph 3
AE115MG/MN/SC	15	4	60	Article 3,*** paragraph 3
AE202MG/MN/SC	25	4	100	Article 3,*** paragraph 3
AE204MG/MN/SC	40	4	160	II
AE205MG/MN/SC	50	4	200	II
AE206MG/MN/SC	65	2	130	II
AE208MG/MN/SC	80	2	160	II
AE210MG/MN/SC	100	2	200	II
AE212MG/MN/SC	125	2	250	II
AE215MG/MN/SC	150	2	300	II
AE220MG/MN/SC	200	2	400	III
AE325MG/MN/SC	250	2	500	III
AE330MG/MN/SC	300	2	600	III
AE335MG/MN/SC	350	2	700	III
AE340MG/MN/SC	400	2	800	III

T01301.EPS

Sanitary

MODEL	DN (mm)*	PS (MPa)*	PS-DN (MPa-mm)	CATEGORY**
AE202MH	25	1	25	Article 3,*** paragraph 3
AE204MH	40	1	40	I
AE205MH	50	1	50	I
AE206MH	65	1	65	I
AE208MH	80	1	80	I
AE210MH	100	1	100	I

T01302.EPS

- * PS: Maximum allowable pressure for Flow Tube
DN: Nominal size
- ** Referred to Table 6 covered by ANNEX II of EC Directive on Pressure Equipment Directive 97/23/EC)
- *** AE102MG/MN/SC to AE202MG/MN/SC, and AE202MH are not attached CE mark of PED because they do not come under CE marking of PED.

(2) Installation



WARNING

- Please tighten the bolts for piping-joint according to the prescribed torque values.
- Please take measure to protect the flowmeters from forces caused by vibration through piping.

(3) Operation



WARNING

- The temperature and pressure of fluid should be applied under the normal operating condition.
- The ambient temperature should be applied under the normal operating condition.
- Please pay attention to prevent the excessive pressure like water hammer, etc. When water hammer is to be occurred, please take measures to prevent the pressure from exceeding PS(maximum allowable pressure) by setting the safety valve, etc. at the system and the like.
- When external fire is to be occurred, please take safety measures at the device or system not to influence the flowmeters.
- Please avoid the fluid exceeding the corrosion proof of lining and electrode.
- Please pay attention not to be abrade the metal pipe, when the fluid to abrade the lining such as slurry and sand are contained.

INSTALLATION AND OPERATING PRECAUTIONS FOR JIS FLAMEPROOF EQUIPMENT

Apparatus Certified Under Technical Criteria (IEC-compatible Standards)

1. General

The following describes precautions on electrical apparatus of flameproof construction (hereinafter referred to as flameproof apparatus) in explosion-protected apparatus.

Following the Labour Safety and Health Laws of Japan, flameproof apparatus is subjected to type tests to meet either the technical criteria for explosionproof electrical machinery and equipment (standards notification no. 556 from the Japanese Ministry of Health, Labour and Welfare) (hereinafter referred to as technical criteria), in conformity with the IEC Standards, or the “Recommended Practice for Explosion-Protected Electrical Installations in General Industries,” published in 1979. These certified apparatus can be used in hazardous locations where explosive or inflammable gases or vapours may be present.

Certified apparatus includes a certification label and an equipment nameplate with the specifications necessary for explosion requirements as well as precautions on explosion protection. Please confirm these precautionary items and use them to meet specification requirements.

For electrical wiring and maintenance servicing, please refer to “Internal Wiring Rules” in the Electrical Installation Technical Standards as well as “USER’S GUIDELINES for Electrical Installations for Explosive Gas Atmospheres in General Industry,” published in 1994.

To meet flameproof requirements, equipment that can be termed “flameproof” must:

- (1) Be certified by a Japanese public authority in accordance with the Labour Safety and Health Laws of Japan and have a certification label in an appropriate location on its case, and
- (2) Be used in compliance with the specifications marked on its certification label, equipment nameplate and precautionary information furnished.

2. Electrical Apparatus of Flameproof Type of Explosion-Protected Construction

Electrical apparatus which is of flameproof construction is subjected to a type test and certified by the Japanese Ministry of Labour aiming at preventing explosion caused by electrical apparatus in a factory or any location where inflammable gases or vapours may be present. The flameproof

construction is of completely enclosed type and its enclosure shall endure explosive pressures in cases where explosive gases or vapours entering the enclosure cause explosion. In addition, the enclosure construction shall be such that flame caused by explosion does not ignite gases or vapours outside the enclosure.

In this manual, the word “flameproof” is applied to the flameproof equipment combined with the types of protection “e”, “o”, “i”, and “d” as well as flameproof equipment.

3. Terminology

(1) Enclosure

An outer shell of an electrical apparatus, which encloses live parts and thus is needed to configure explosion-protected construction.

(2) Shroud

A component part which is so designed that the fastening of joint surfaces cannot be loosened unless a special tool is used.

(3) Enclosure internal volume

This is indicated by:— the total internal volume of the flameproof enclosure minus the volume of the internal components essential to equipment functions.

(4) Path length of joint surface

On a joint surface, the length of the shortest path through which flame flows from the inside to outside of the flameproof enclosure. This definition cannot be applied to threaded joints.

(5) Gaps between joint surfaces

The physical distance between two mating surfaces, or differences in diameters if the mating surfaces are cylindrical.

Note: The permissible sizes of gaps between joint surfaces, the path length of a joint surface and the number of joint threads are determined by such factors as the enclosure’s internal volume, joint and mating surface construction, and the explosion classification of the specified gases and vapours.

4. Installation of Flameproof Apparatus

(1) Installation Area

Flameproof apparatus may be installed, in accordance with applicable gases, in a hazardous area in Zone 1 or 2, where the specified gases are present. Those apparatus shall not be installed in a hazardous area in Zone 0.

Note: Hazardous areas are classified in zones based upon the frequency of the appearance and the duration of an explosive gas atmosphere as follows:

Zone 0: An area in which an explosive gas atmosphere is present continuously or is present for long periods.

Zone 1: An area in which an explosive gas atmosphere is likely to occur in normal operation.

Zone 2: An area in which an explosive gas atmosphere is not likely to occur in normal operation and if it does occur it will exist for a short period only.

(2) Environmental Conditions

The standard environmental condition for the installation of flameproof apparatus is limited to an ambient temperature range from -20°C to $+40^{\circ}\text{C}$ (for products certified under Technical Criteria). However, some field-mounted instruments may be certified at an ambient temperature up to $+60^{\circ}\text{C}$ as indicated on the instrument nameplates. If the flameproof apparatus are exposed to direct sunshine or radiant heat from plant facilities, appropriate thermal protection measures shall be taken.

5. External Wiring for Flameproof Apparatus

Flameproof apparatus require cable wiring or flameproof metal conduits for their electrical connections. For cable wiring, cable glands (cable entry devices for flameproof type) to wiring connections shall be attached. For metal conduits, attach sealing fittings as close to wiring connections as possible and completely seal the apparatus. All non-live metal parts such as the enclosure shall be securely grounded. For details, see the "USER'S GUIDELINES for Electrical Installations for Explosive Gas Atmospheres in General Industry," published in 1994.

(1) Cable Wiring

- Specific cables shall be used as recommended by the "USER'S GUIDELINES for Electrical Installations for Explosive Gas Atmospheres in General Industry," published in 1994.
- In necessary, appropriate protective pipes (conduit or flexible pipes), ducts or trays shall be used for preventing the cable run (outside the cable glands) from damage.
- To prevent explosive atmosphere from being propagated from Zone 1 or 2 hazardous location to any different location or non-hazardous location through the protective pipe or duct, apply sealing of the protective pipes in the vicinity of individual boundaries, or fill the ducts with sand appropriately.
- When branch connections of cables, or cable connections with insulated cables inside the conduit pipes are made, a flameproof or increased-safety connection box shall be used. In this case, flameproof or increased-safety cable glands meeting the type of connection box must be used for cable connections to the box.

(2) Flameproof Metal Conduit Wiring

- For the flameproof metal conduit wiring or insulated wires shall be used as recommended by the USER'S GUIDELINES for Electrical Installations for Explosive Gas Atmospheres in General Industry, published in 1994.
- For conduit pipes, heavy-gauge steel conduits conforming to JIS C 8305 Standard shall be used.
- Flameproof sealing fittings shall be used in the vicinity of the wiring connections, and those fittings shall be filled with sealing compounds to complete sealing of the apparatus. In addition, to prevent explosive gases, moisture, or flame caused by explosion from being propagated through the conduit, always provide sealing fittings to complete sealing of the conduit in the following locations:
 - (a) In the boundaries between the hazardous and non-hazardous locations.
 - (b) In the boundaries where there is a different classification of hazardous location.
- For the connections of the apparatus with a conduit pipe or its associated accessories, G-type parallel pipe threads (JIS B 0202) shall be used to provide a minimum of five-thread engagement to complete tightness. In addition, since these parallel threads do not have sealing property, nonhardening sealant such as liquid gaskets shall thus be applied to those threads for ensuring waterproofness.
- If metal conduits need flexibility, use flameproof flexible fittings.

6. Maintenance of Flameproof Apparatus

To maintain the flameproof apparatus, do the following. (For details, see Chapter 10 “MAINTENANCE OF EXPLOSION-PROTECTED ELECTRICAL INSTALLATION” in the USER’S GUIDELINES for Electrical Installations for Explosive Gas Atmospheres in General Industry.)

(1) Maintenance servicing with the power on.

Flameproof apparatus shall not be maintenance-serviced with its power turned on. However, in cases where maintenance servicing is to be conducted with the power turned on, with the equipment cover removed, always use a gas detector to check that there is no explosive gas in that location. If it cannot be checked whether an explosive gas is present or not, maintenance servicing shall be limited to the following two items:

- (a) Visual inspection
Visually inspect the flameproof apparatus, metal conduits, and cables for damage or corrosion, and other mechanical and structural defects.
- (b) Zero and span adjustments
These adjustments should be made only to the extent that they can be conducted from the outside without opening the equipment cover. In doing this, great care must be taken not to cause mechanical sparks with tools.

(2) Repair

If the flameproof apparatus requires repair, turn off the power and transport it to a safety (non-hazardous) location. Observe the following points before attempting to repair the apparatus.

- (a) Make only such electrical and mechanical repairs as will restore the apparatus to its original condition. For the flameproof apparatus, the gaps and path lengths of joints and mating surfaces, and mechanical strength of enclosures are critical factors in explosion protection. Exercise great care not to damage the joints or shock the enclosure.
- (b) If any damage occurs in threads, joints or mating surfaces, inspection windows, connections between the transmitter and terminal box, shrouds or clamps, or external wiring connections which are essential in flameproofness, contact Yokogawa Electric Corporation.



CAUTION

Do not attempt to re-process threaded connections or refinish joints or mating surfaces.

- (c) Unless otherwise specified, the electrical circuitry and internal mechanisms may be repaired by component replacement, as this will not directly affect the

requirements for flameproof apparatus (however, bear in mind that the apparatus must always be restored to its original condition). If you attempt to repair the flameproof apparatus, company-specified components shall be used.

- (d) Before starting to service the apparatus, be sure to check all parts necessary for retaining the requirements for flameproof apparatus. For this, check that all screws, bolts, nuts, and threaded connections have properly been tightened.

(3) Prohibition of specification changes and modifications

Do not attempt to change specifications or make modifications involving addition of or changes in external wiring connections.

7. Selection of Cable Entry Devices for Flameproof Type



IMPORTANT

The cable glands (cable entry devices for flameproof type) conforming to IEC Standards are certified in combination with the flameproof apparatus. So, Yokogawa-specified cable entry devices for flameproof type shall be used to meet this demand.

References:

- (1) Type Certificate Guide for Explosion-Protected Construction Electrical Machinery and Equipment (relating to Technical Standards Conforming to International Standards), issued by the Technical Institution of Industrial Safety, Japan
- (2) USER’S GUIDELINES for Electrical Installations for Explosive Gas Atmospheres in General Industry (1994), issued by the Japanese Ministry of Health, Labour and Welfare, the Research Institute of Industrial Safet