

GSM Intelligent Alarm System

Installation and User Manual







3. Wireless Remote Controller

- Power supply: DC = 12V ~ 8.4V
- Static Current: I1 = 0
- Transmission Current: I2 ≤ 15mA
- Transmission Frequency: f = 315/433.92 ± 0.2MHz
- Transmission Time: T ≤ 1s
- Transmission Distance: No Obstacle ≥ 80m
- Working Condition: Temperature: -10℃ ~ +40℃
- Relative Humidity: ≤ 90%

V. Frequency Questions & Answers

| Problems | Probable Reasons | Solutions |
|--|--|--|
| Main panel can't dial when alarming | <ul style="list-style-type: none"> 1.No GSM antenna mounted 2.Invalid SIM Card or short of fee 3.Alarm (or center) number are incorrect 4. Misuse detectors or not make valid coding | <ul style="list-style-type: none"> 1. Mount the antenna correctly 2. Make sure SIM card in the working condition 3.Set phone numbers correctly 4. Install and use the detectors according to user manual |
| Fail to set alarm number or message by SMS | <ul style="list-style-type: none"> 1.The format is incorrect 2.Password is invalid | <ul style="list-style-type: none"> 1. Set the numbers followed by user manual 2. Use initial password after reset |
| Can't setup or control from long distance | <ul style="list-style-type: none"> 1. Wrong password or no corresponding actions 2. Too fast key pressing result from unstable detection | <ul style="list-style-type: none"> 1. Input the right password, receiving "Di" tone when make the correct action. 2. Pressing the key firmly |
| Can't work if remove DC power | <ul style="list-style-type: none"> 1.No backup battery available 2.Backup battery switch turns off | <ul style="list-style-type: none"> 1. Use backup battery(optional) 2. turn the switch on |
| External wired detectors work | <ul style="list-style-type: none"> 1. The connection between the panel and detector is incorrect 2. Misunderstanding Low | <ul style="list-style-type: none"> 1. Make the connection correctly according to the manual 2. Confirm to use the suitable |

The remote controller has three buttons or four buttons: Arm Button , or At home arm button , Disarm Button , Panic Button . When press Arm Button, status LED on the panel blinks about 25s, then armed (delay arm). Press arm followed by panic button immediately would get into arm status at once (instant arm). At home arm button has the same operation as arm button except only specified at home armed detectors could activate the alarm. Pressing Panic button would activate the alarm, and Disarm button would release and cancel the alarm at any time.

IV. Technical parameters for wireless detectors

1. Wireless gap (door/window) Detector

| | |
|-------------------------|--|
| Power supply: | DC = 12V ~ 8.4V(inner battery DC=1.2V) |
| Static Current: | $I_1 \leq 15\mu A$ |
| Transmission Current: | $I_2 \leq 15mA$ |
| Transmission Frequency: | $f = 315/433.92 \pm 0.2MHz$ |
| Transmission Time: | $T \geq 1S$ |
| Transmission Distance: | No Obstacle $\geq 80m$; |
| Internal distance: | 15mm |
| Working Temperature: | $-10^{\circ}C \sim +40^{\circ}C$ |
| Relative Humidity: | $\leq 90\%$ |

2. Wireless P.I.R. Detector

| | |
|-----------------------------|--|
| Power supply: | DC = 9V ~ 7.2V(inner battery DC=9V) |
| Static Current: | $I_1 \leq 30\mu A$ |
| Transmission Current: | $I_2 \leq 20mA$ |
| Transmission Frequency: | $f = 433.92$ (or 315) $\pm 0.2MHz$ |
| Transmission Time: | $T \geq 1s$ |
| Transmission Distance : | No Obstacle $\geq 80m$ |
| Preheating Time : | $\leq 2min.30s$ |
| Interval of twice Emission: | $\leq 35s$ |
| Detected Distance: | 5 ~ 15m |
| Detected Angle: | Horizontal: 110° , Vertical: 60° |
| Working Condition: | Temperature: $-10^{\circ}C \sim +40^{\circ}C$ |
| Relative Humidity : | $\leq 90\%$ |

Table Of Content

| | |
|--|----|
| Overview | 1 |
| I. The installation of the alarm system | |
| 1. Installation of main panel..... | 3 |
| 2. Installation of door detector..... | 4 |
| 3. Installation of P.I.R. | 4 |
| II. The usage of main panel | |
| 1. Setting Alarm phone number | 5 |
| 2. Setting alarm message..... | 6 |
| 3. Coding between main panel and wireless detectors..... | 7 |
| 4. Make alarm and answer..... | 7 |
| 5. Setting function of main panel..... | 8 |
| 6. The LEDs on the main panel..... | 9 |
| III. Usage of wireless remote controller | 10 |
| IV. Technical parameters for wireless detectors..... | 11 |
| V. Frequency Questions & Answers..... | 12 |

Overview

Thanks for selecting the GSM alarm system, please read the user manual carefully before installation and operation.

GSM intelligent alarm system, has all the function of traditional telephone alarm system, moreover it takes the advantage of GSM network and short text message, it would be used more convenient, reliable, and efficient.

1. Fundamental function of the system

- 1) Support multi GSM bands, This panel suits for:
 - GSM900/DCS1800 MHz
 - GSM900/DCS1800/1900 MHz
 - GSM850/900/DCS1800/1900 MHz
- 2) The main panel has the option which supports Alarm center , please check when selecting, this panel:
 - Does not support alarm center
 - Supports Ademco Contact ID format alarm center
 - Supports other format alarm center
- 3) No need of fixed telephone line. It is very suitable for cottage, house, shop, garage, wherever GSM Network is present.
- 4) Sends preset messages to the mobile phone whenever alarm is activated.
- 5) Easy to setup alarm phone numbers and sending messages through SMS.
- 6) Supports up to 7 wired sensors.
- 7) Main panel supports all kinds of wireless detectors, PIR, infrared balusters, smoke sensors, gas sensors, panic buttons and so on.
- 8) Indicates up to 30 Activated Zone numbers, display zone numbers when the sensors make alarm and coding.
- 9) Sets the system status(Arm, Disarm etc.) by a telephone or SMS.
- 10) Makes arm, disarm, or panic through remote controllers.
- 11) Four digits password is used for remote access for security reasons.
- 12) Onsite voice Monitoring through telephone from long distance.
- 13) Have one onsite high volume siren, send sound when alarm occurs.
- 14) One onboard relay available for customer application.
- 15) One open collector output available to be used according to customer demands

- 2) Input indicator (INPUT): lit when any of input from IN1 to IN7 activated, extinguished for no status change.
- 3) Relay indicator (RELAY): lit when inside relay closed, and extinguished when opened.
- 4) Siren indicator (SIREN): lit when siren is ringing, extinguished while not ringing.
- 5) Monitor indicator (MONITOR): lit when get into onsite monitor status, and extinguished without monitoring.
- 6) GSM signal indicator (SIGNAL): blinked when searching GSM signal and alarm phone numbers, dialing, and connecting, lit in standby, extinguished if there are no signal or valid alarm phone numbers.

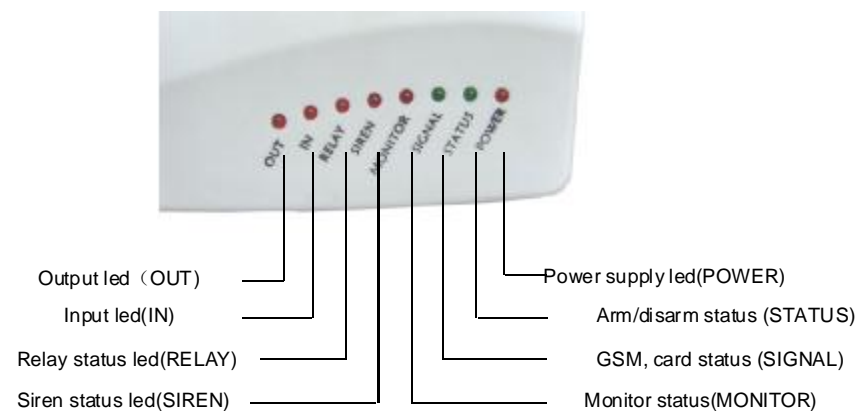

- 7) Status indicator (STATUS): lit when armed, extinguished for disarmed, blinked for alarming and delay arm.
- 8) Power indicator (POWER): lit when power on.
- 9) Zone indicator (ZONE ID) :

“8”LEDs on the top right corner of panel represents the zone numbers, display “1 - 9”and “A - F”, digit “1-7”represent external wired input zone I1 to I7, “8-F” represents wireless zone 8-15, “1-F” with the lit point “.” represents wireless zone 16-30.

III. Usage of wireless remote controller

- 6# Release alarm, main panel ends alarming and connection
- 7# Siren rings when alarm is activated(default)
- 7* No ring when alarm activated
- 8# ****# Change to new password****
- 9# Disable onsite monitoring (default)
- 9* Enable onsite monitoring

Attention:

Each operation is ended with “#”or “*”, one beep indicates one successful action, no beep indicates the action is invalid, please check and try again.

Method 2: Setting by SMS

Sending SMS to main panel number through cell phone with the following format:

- 1) ****XXXXXXXX[XXXXXXXX](Content of SMS) ,
Set main panel status, the content of SMS includes:
ARM
DISARM
OUTPUT ON
OUTPUT OFF
RELAY ON
RELAY OFF
eg: “1234ARM, OUTPUT ON, RELAY OFF”
Represents setting main panel Arm, output on (high), relay on(closed)
- 2) Set new password to “6789”
1234#PW#6789
- 3) Set main panel ID “0008” when need alarm center network
1234#ID#0008
- 4) Setting the number “13888888888” to A3(alarm telephone).
1234#A3#1388888888
- 5) Setting the message“1 external input alarm” to SIM card.
1234#SM#1 external input alarm

6. The LEDs on the main panel

- 1) Output indicator (OUT): lit when output high level, extinguished when output low level.

2. Basic kits configuration

| | |
|--------------------------|-------|
| Main panel(with antenna) | 1 set |
| Power supply | 1 pc |
| Wireless P.I.R. | 1 pc |
| Wireless Door detector | 1 set |
| Remote controller | 2 pcs |
| External siren | 1 pc |
| User manual | 1 pc |

Optional: backup battery, wireless smoke detector, wireless gas detector, wireless infrared curtain sensor, panic button etc.



Figure1. the main panel of the alarm system

3. Technical Parameters:

- 1) Power supply: AC110V/220V ~ DC12V 1A
- 2) Static Current: < 30mA
- 3) GSM power: CLASS4 (2W) /EGSM850/900,
CLASS1 (1W) /DCS1800/1900
- 4) Wireless frequency: 433.92(or 315 if specified) MHz
- 5) Wireless Modulation: ASK

- 6) Wireless receive sensitivity: -95dBm@12dB SINAD
- 7) Support wireless detectors: 28
- 8) Volume of siren: $\geq 110\text{dBspl}$
- 9) Working Temperature: $-15^{\circ}\text{C} \sim +55^{\circ}\text{C}$ R. H. $\leq 90\%$

I. The installation of the alarm system

1. Installation of main panel

The main panel should be installed firmly wherever there is GSM signal and power supply, no additional wired connection needed.

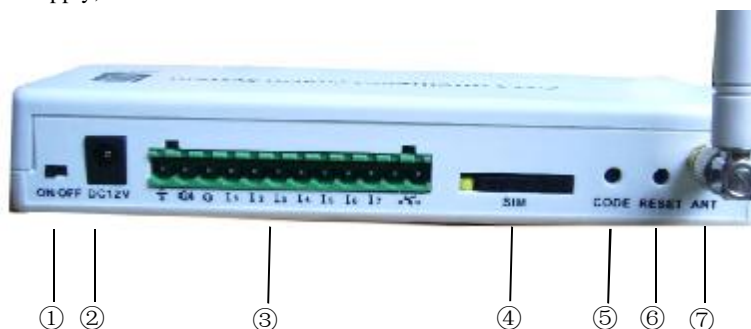

Figure2. the external interface in the rear of main panel.

- ① Backup battery (optional) switch, the battery could keep the system work a few hours without external power supply.
- ② External power supply socket, DC 12V/1A, inner Anode.
- ③ External 12 pins interface, see Note 3.
- ④ SIM card, eject the tray by pressing the yellow button, push it back after putting the card into the tray.
- ⑤ CODE pressing key, code(register) for main panel and wireless detectors.
- ⑥ RESET pressing key, keep pressing the key when power on to initialize all the parameter to factory settings.
- ⑦ Antenna Port, connect antenna before operation, keep the antenna is in vertical for better performance.

Note 3: External 12 pins interface, from left to right:
Pin 1: Common ground.

2) Alarm Activated

The following way could activate the alarm of main panel:

When the main panel is in arm status, any level change(more than 100ms) in the wired input terminal I1 to I7, pressing panic button of remote controller, pressing button of panic button, alarm signal from PIR, door detector, gas detector, smoke detector etc.

3) Valid answer/release alarm

When one alarm activated, the siren rings, main panel sends alarm message, followed by dialing alarm phone number (dialing alarm center number at first if alarm center is supported) continuously up to 5 times if there is no valid answer or release action.

If user answer the alarm phone, after entering the valid password, pressing "6#" would release this alarm, also user could press disarm button of the remote controller to cancel the alarm, otherwise the main panel would not stop alarm until five rounds dialing.

5. Setting function of main panel

Method 1: Remote control by telephone

When user dial the main panel, connection established about 10 seconds, then enter "****#" (password and "#", the default password is 1234) by pressing the keys of the talking phone, after one beep, user could make the following function configuration through pressing the keys.

| | |
|-----------|--|
| 0# | Arm (default) |
| 0* | Disarm |
| 1# | Output high |
| 1* | Output low (default) |
| 2# | Report the status(when make arm/disarm) to alarm center Enable (for panels support alarm center) |
| 2* | Report the status to alarm center Disable(default) |
| 3# **** # | Set ID (****) of main panels(for panels support alarm center) |
| 4# | Relay closed |
| 4* | Relay opened (default) |
| 5# | Send SMS when alarm activated (default) |
| 5* | Do not send SMS when alarm activated |

3. Coding between main panel and wireless detectors

All wireless detectors had been registered (coded) to the main panel from the factory. But it is absolutely necessary to clear the coding process:

1) Coding during the specified time

Keep pressing “Code” key for about 4s to 5s until one beep, then release the key, the system is in coding status. Make the wireless detectors work and send signal(eg. Press buttons of remote controller, turn on PIR, move the two parts of door detectors away), then main panel receives the signal, decodes the data and then saves them as the identified numbers into its memories, this coding process finished, user could make more detectors coding in turn, about 25 seconds later, coding status ended with one beep.

Attention: Main panel will send two beeps “Di - Di” when make one coding successfully, meanwhile, Zone ID LED would display its numbers accordingly.

2) Adding code

If user want to add more detectors codes and not remove the existed ones, just press “Code” key for 2s to 3s, release and then press again, after one beep, the system is in coding status, the coding process is the same as above description, after finishing coding, Press “Code” key again, the main panel ends coding process with one beep, the previous codes still remained.

3) Remove the code or re-code

Make the coding process according to above 1) process, code what you want, others would be lost automatically.

4. Make alarm and answer

1) System startup and initialization

Firstly connect the antenna, input SIM card, then plug in power supply, the status LED lit if setup Arm status, then Signal LED blinked when the system are searching network signal and initialization, Signal LED lit when successful initialization, extinguished if there is no signal or valid alarm phone(Center) numbers .

Pin 2: Siren output positive, negative is connected to common ground.

Pin 3: Output terminal, composed with common ground.

Pin 4 to Pin 10 are wired input terminals, each composed with common ground, Self adapt alarm activated, that is more than 100ms level change in the working situation would activate the alarm.

Pin 11 and Pin 12 are the input and output terminals of onboard relay. Closed when Relay is on, and open when off.

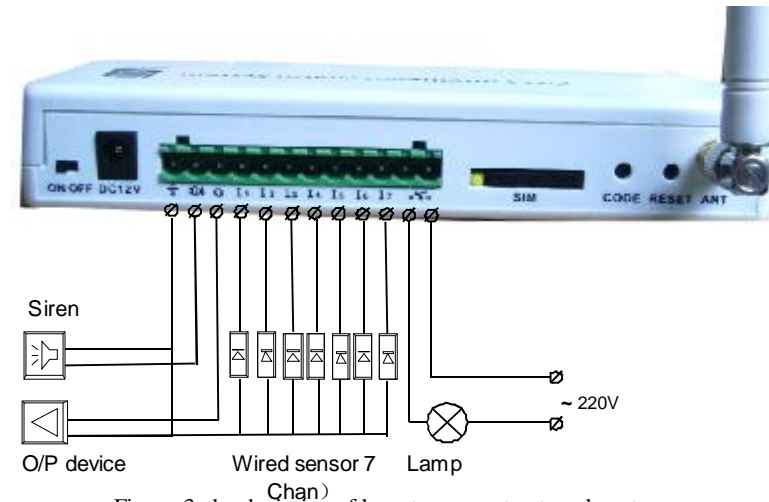

Figure 3. the depiction of how to connect external ports

2. Installation of door detector

From the principle of Magnetic Door/Window detector: When the gap of magnet and Magnetron is increased to a certain distance, the magnetism decreases accordingly and the switch in the Magnetron turns on and result from alarming. It can detect the opening of doors and windows. Magnet part is easy to install on doors or windows, the other part then fixed on the door frames by adhesive tape, the activated gap is about 15mm.

3. Installation of P.I.R.

PIR could detect body in the certain range. Detection distance is from 5 to 15 meters (adjustable), Horizontal detection angle is 110 degrees, and vertical detection angle is 60 degrees. Adjust the direction and distance to the suitable

position and then fix the PIR on the wall or the furniture. Please be noted: the position and direction of the PIR would affect the detection performance, please contact your suppliers if you meet difficulties when make the installation.

II. The usage of main panel

1. Setting alarm telephone numbers

Before use this panel, you must set alarm phone(or alarm center) numbers, up to 7 alarm phone number could be set in SIM card by the user name A1 to A7, when alarms activated, main panel would dial the alarm numbers A1 to A7 in turn, meanwhile send alarm messages to the alarm phone numbers.

Method 1 for setting the alarm numbers:

Put the SIM card into one GSM cell phone and save alarm phone numbers in SIM card, by the name A1 to A7 respectively. No longer than 20 digits for each number, no "+" needed for international numbers, no country code for domestic numbers.

Please pay attention: If the main panel support alarm center, then A1,A2 would be saved to Alarm center phone number, and A3-A7 would represent Alarm phone No. 1 to 5, when alarm activated, the main panel would dial Alarm Center number A1,A2 at first, then dial alarm phone number A3-A7 in turn.

Method 2

Sending short message to main panel number through cell phone with the format:

***#A1(A2/A3/A4/A5/A6,A7)######

In this manual, if there is no particular declaration,

“****” represents 4 digits password, default is “1234”, A1 to A7 represent alarm phone No., “#####” represents valid 8 digits phone number, two “#” besides A1-A7 is the must, which is the particular format, “XXXXXXXXXX” represents text characters,

For example:

1234#A1#88888888

Setting the number “88888888” to A1 (alarm phone No.1).

2. Setting alarm message

The alarm message is the corresponding text information(SMS) sent to user mobile phones which preserved in the main panel when this zone alarm is activated, those messages are created by the main panel by the default format “1(2-35) zone activated” in the initialization process.

Messages 1 to 7 are corresponding to wired input 1 to 7, when wired input 1 activated, message 1 would be sent to alarm phone numbers.

Messages 8 to 35 are corresponding to the wireless alarm detectors which registered with the main panel, such as PIR, smoke detector, gas detector and so on. When there is one alarm activated, e.g. Zone 8, then the message 8 in the SIM card would be sent to the alarm phone numbers.

Also user could change the content of messages according to the detail requirement through the following method:

Method 1

Put the SIM card into one GSM cell phone, if the card is initialized by the main panel, there should be those messages in the card, user just edit the corresponding text to require content. Also user could add the SMS into the SIM card by the following format:

1(2-35)XXXXXXXXXX(the text content)

For example: edit the message: “8 wireless door detector alarm”, the message would be sent, when zone 8 is activated.

Method 2

Sending SMS to main panel number by the following format:

***#SM#1(2-35)XXXXXXXXXX

For example: “1234#SM#5 external input is alarming”,

Then the message “5 external input alarm is alarming” would save to SIM card as the alarm message.

Note:

- 1) The digits 1-35 in the head of each message is the must, otherwise they would not be corresponded to wired and wireless alarm zone numbers. The length of each message is not more than 100 letters, exceeded parts would be probably missed.
- 2) All messages are saved into SIM card, the panel would only deal with message 1 to 18 if the messages capability of the card is 20.