

Kit 57395

**2011- Ford F-250/ F-350/F-450
2WD Pickups
(Single & Dual Rear Wheel)**

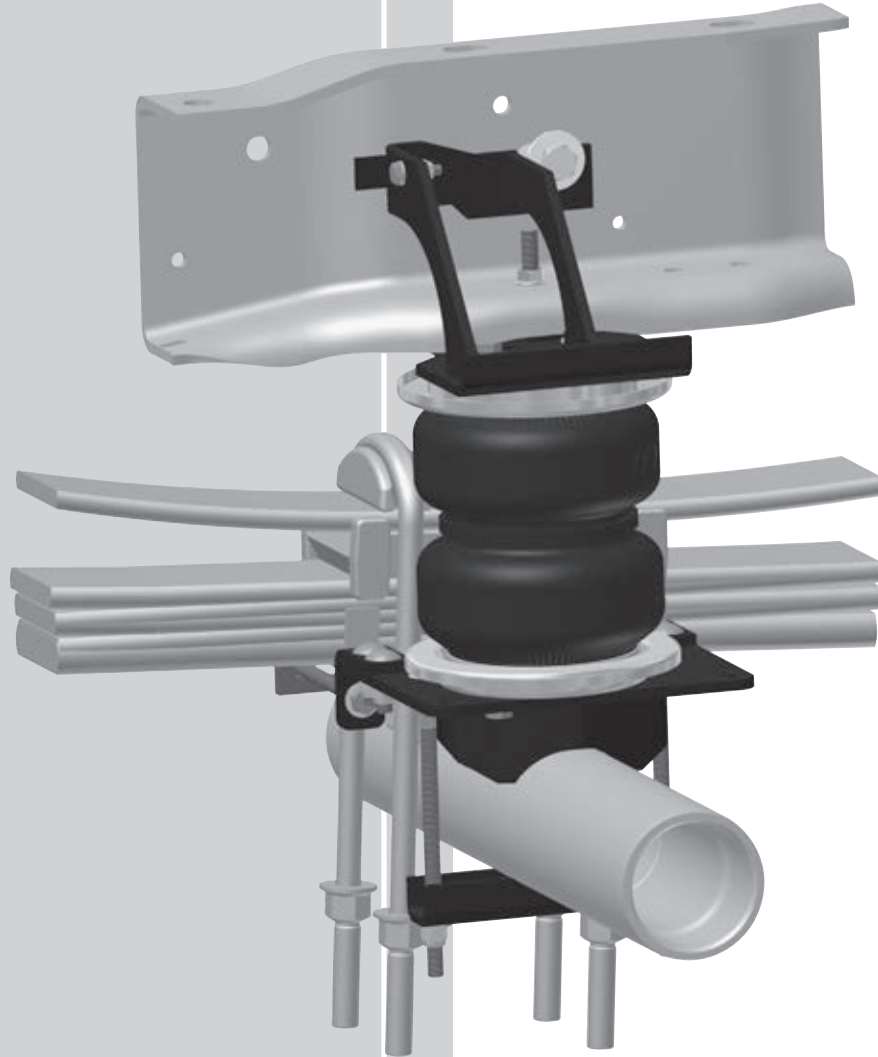

INSTALLATION GUIDE

For maximum effectiveness and safety, please read these instructions completely before proceeding with installation.

Failure to read these instructions can result in an incorrect installation.



TABLE OF CONTENTS

Introduction	2
Important Safety Notice	2
Notation Explanation	2
Installation Diagrams	3
Installation Diagram - Driver Side	3
Installation Diagram - Passenger Side	4
Hardware List	5
Tools List	5
Installing the LoadLifter 5000 System.	6
Getting Started	6
Installing the Upper Bracket	6
Lower Bellows and Bracket Assembly.	7
Positioning the Assembly on the Axle	8
Driver Side Upper Bracket Installation.	9
Passenger Side Upper Bracket Installation.	10
Lower Bracket Attachment	10
Installing the Air Lines	12
Installing the Heat Shield.	13
Checking for Leaks	14
Fixing Leaks	14
Before Operating	15
Installation Checklist	15
Post-Installation Checklist	15
Product Use, Maintenance and Servicing.	15
Suggested Driving and Maximum Pressure	15
Maintenance Guidelines	16
Troubleshooting Guide	16
Frequently Asked Questions	17
Tuning the Air Pressure.	17
Guidelines for Adding Air.	18
Warranty and Returns Policy	19
Replacement Parts and Information	20
Replacement Information	20
Contact Information	21

Introduction

The purpose of this publication is to assist with the installation, maintenance and troubleshooting of the LoadLifter 5000 air spring kit. LoadLifter 5000 utilizes sturdy, reinforced, commercial grade single or double, depending on the kit, convolute bellows. The bellows are manufactured like a tire with layers of rubber and cords that control growth. LoadLifter 5000 kits are recommended for most 3/4 and 1 ton pickups and SUVs with leaf springs and provide up to 5,000 lbs. of load leveling support with air adjustability from 5-100 PSI. The kits are also used in motor home rear kits and some motor home fronts where leaf spring are used.

It is important to read and understand the entire installation guide before beginning installation or performing any maintenance, service or repair. The information here includes a hardware list, tool list, step-by-step installation information, maintenance guidelines and operating tips.

Air Lift Company reserves the right to make changes and improvements to its products and publications at any time. For the latest version of this manual, contact Air Lift Company at (800) 248-0892 or visit our website at www.airliftcompany.com.

IMPORTANT SAFETY NOTICE

The installation of this kit does not alter the Gross Vehicle Weight Rating (GVWR) or payload of the vehicle. Check your vehicle's owner's manual and do not exceed the maximum load listed for your vehicle.

Gross Vehicle Weight Rating: The maximum allowable weight of the fully loaded vehicle (including passengers and cargo). This number — along with other weight limits, as well as tire, rim size and inflation pressure data — is shown on the vehicle's Safety Compliance Certification Label.

Payload: The combined, maximum allowable weight of cargo and passengers that the truck is designed to carry. Payload is GVWR minus the Base Curb Weight.

NOTATION EXPLANATION

Hazard notations appear in various locations in this publication. Information which is highlighted by one of these notations must be observed to help minimize risk of personal injury or possible improper installation which may render the vehicle unsafe. Notes are used to help emphasize areas of procedural importance and provide helpful suggestions. The following definitions explain the use of these notations as they appear throughout this guide.

DANGER

INDICATES IMMEDIATE HAZARDS WHICH WILL RESULT IN SEVERE PERSONAL INJURY OR DEATH.

WARNING

INDICATES HAZARDS OR UNSAFE PRACTICES WHICH COULD RESULT IN SEVERE PERSONAL INJURY OR DEATH.

CAUTION

INDICATES HAZARDS OR UNSAFE PRACTICES WHICH COULD RESULT IN DAMAGE TO THE MACHINE OR MINOR PERSONAL INJURY.

NOTE

Indicates a procedure, practice or hint which is important to highlight.

Installation Diagram - Driver Side

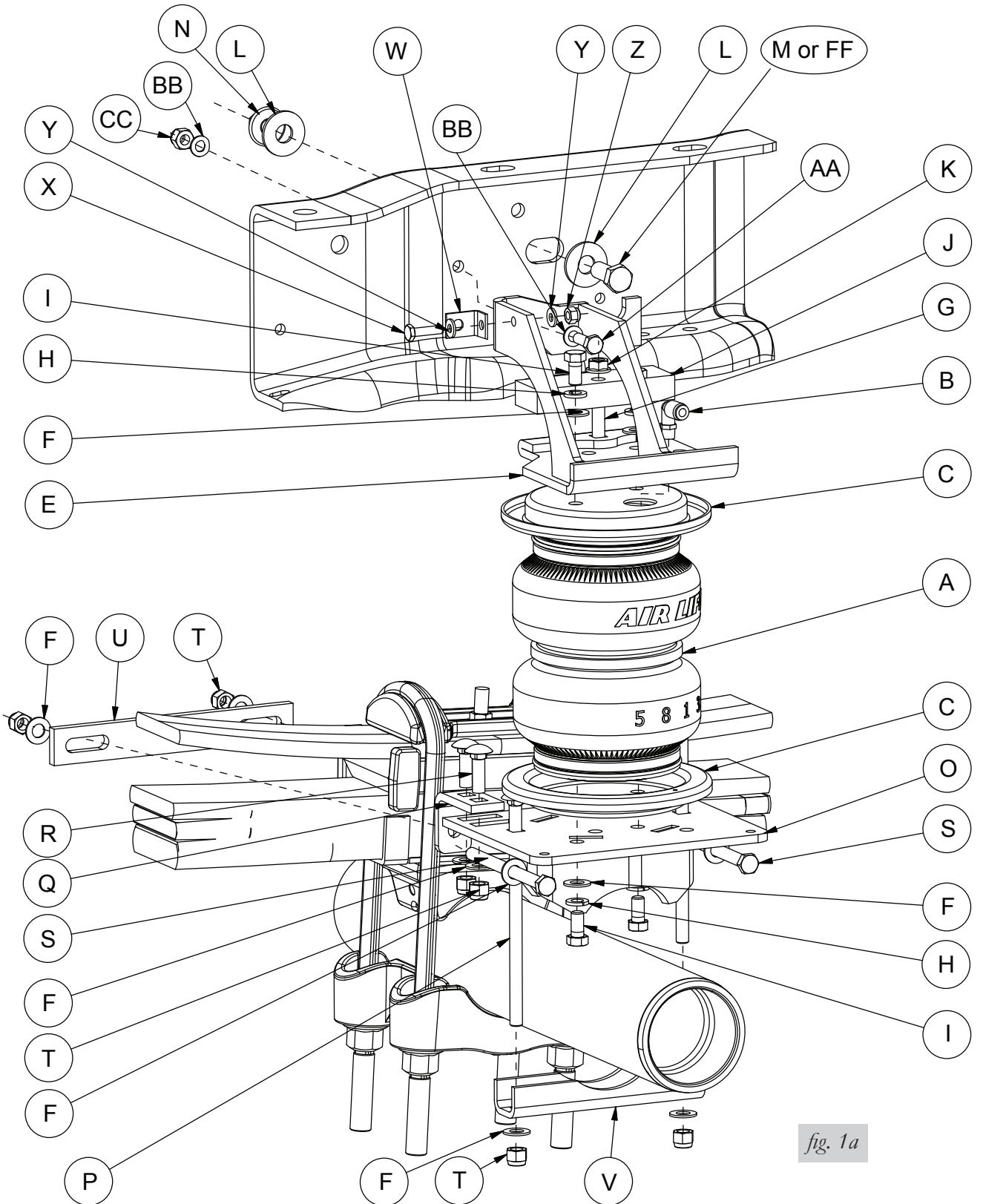

fig. 1a

Installation Diagram - Passenger Side

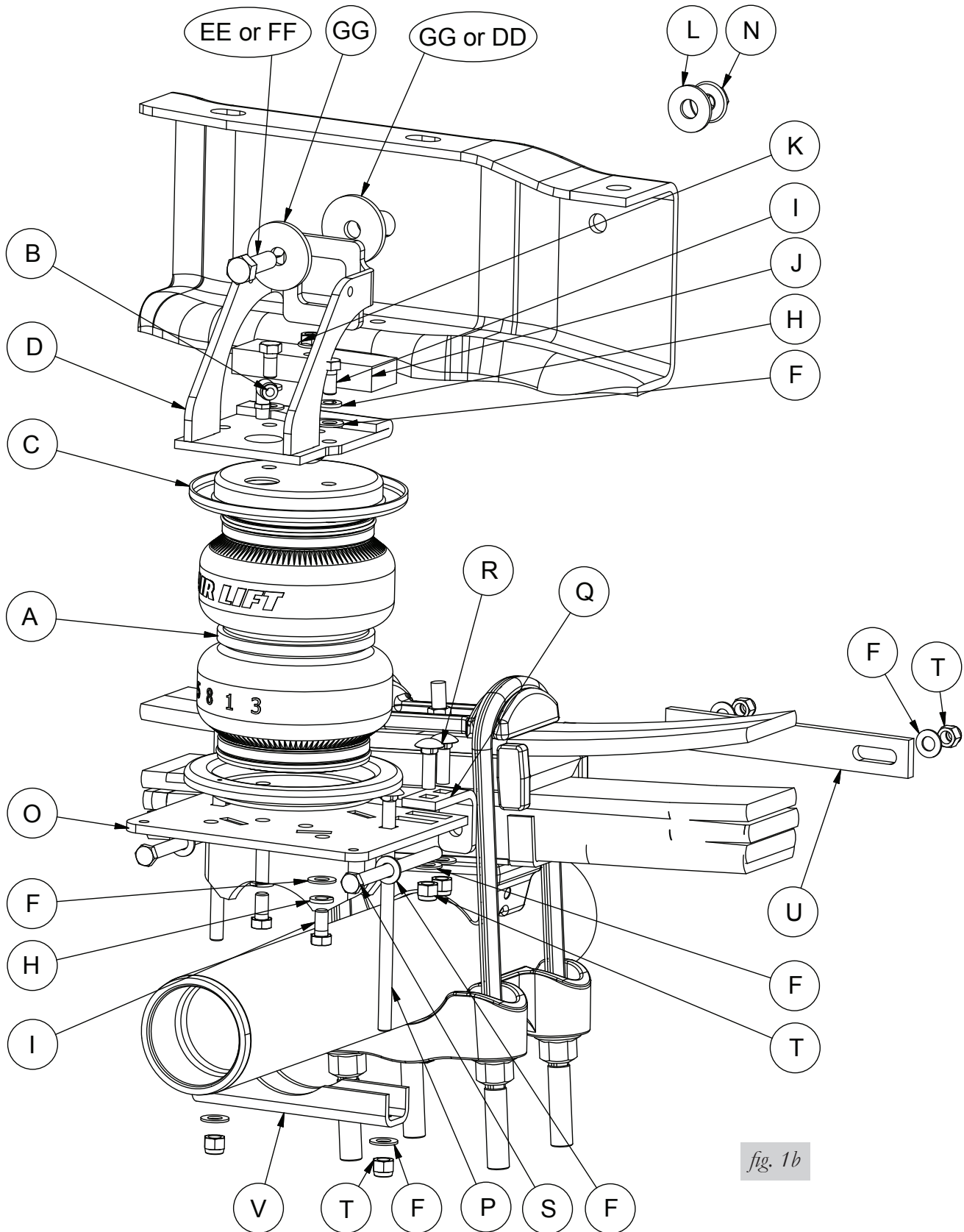

fig. 1b

Hardware and Tools Lists

HARDWARE LIST

Item	Part #	Description	Qty
A	58437	Bellows.....	2
B	21837	90° Swivel Air Fitting.....	2
C	11951A	Roll Plate.....	4
D	07148	Upper Bracket.....	1
E	07993	L.H. Upper Bracket.....	1
F	18444	3/8" Flat Washer.....	28
G	17141	3/8"-16 X 2.5 Carriage Bolt.....	2
H	18427	3/8" Lock Washer.....	8
I	17203	3/8"-24 X 3/4 Hex Bolt.....	8
J	13966	Spacer.....	2
K	18422	3/8"-16 Serrated Flange Lock Nut.....	2
L	18485	1/2" Flat Washer.....	3
M	17412	1/2"-13 X 1.25" Hex Cap Screw.....	1
N	18505	1/2"-13 Serrated Flange Lock Nut.....	2
O	03211	Lower Bracket.....	2
P	17163	3/8"-16 X 7" Carriage Bolt.....	4
Q	11067	Locating Bracket.....	4
R	17361	3/8"-16 X 1.25" Carriage Bolt.....	8
S	17184	3/8"-16 X 5.0" Hex Tap Bolt.....	4
T	18435	3/8"-16 Nyloc Nut.....	17
U	10861	Retainer Plate.....	2
V	01531B	Clamp Bar.....	2
W	10886	L Bracket.....	1
X	17135	1/4"-20 X 1" Hex Cap Screw.....	1
Y	18419	Flat Washer.....	2
Z	18425	1/4"-20 Nyloc Nut.....	1
AA	17177	M8-1.25" X 25 Hex Bolt.....	1
BB	18501	M8 Flat Washer.....	2
CC	18522	M8 X 1.25" Nyloc Nut.....	1
DD	18556	3/4" Plain Washer.....	1
EE	17161	1/2"-13 X 1.5" Hex Head Bolt.....	1
FF	17271	1/2"-13 X 3" Hex Cap Screw.....	2
GG	18207	Flat Washer.....	2

TOOLS LIST

Description.....	Qty
Metric & STD Open-Box End Wrenches.....	set
Ratchet with Metric and STD Sockets.....	set
Drill and 5/16" Drill Bit.....	1
Torque Wrench.....	1
Hose Cutter, Razor Blade or Sharp Knife.....	1
Hoist or Floor Jack.....	1
Safety Stands.....	2
Safety Glasses.....	1
Air Compressor or Compressed Air Source.....	1
Spray Bottle with Dish Soap/Water Solution.....	1



Missing or damaged parts? Call Air Lift customer service at (800) 248-0892 for a replacement part.

Installing the LoadLifter 5000 System

GETTING STARTED

1. Raise the vehicle and support the axle with jack stands, setting the jack stands as wide as possible on the axle.
2. Remove the jounce bumpers from under the frame, over the axle.
3. If necessary, disconnect the wiring harness from the driver side frame rail to gain clearance for the upper bracket.

NOTE

Gas engine models have emission lines on the inside of the frame. Follow the directions in the section, "Installing the Upper Bracket," for relocating these lines.

4. If you have a fifth wheel hitch already installed, it will be necessary to remove the 3/4" hardware that bolts the side bracket to the outside of the frame above the axle (fig. 2a or 2b).

INSTALLING THE UPPER BRACKET

1. Insert a 3/8" carriage bolt (G) through the bottom of the upper bracket (D) and (E) (fig. 2a or 2b). Set the spacer (J) over the carriage bolt.

NOTE

The hole in the flat spacer (J) is offset. Install the spacer so that the wide portion faces the outside of the vehicle.

NOTE

If your model truck has emission lines running along the inside of the frame rail (fig. 3), it will be necessary to relocate those lines as follows:

- *Carefully push the line holder out of the frame above the axle. Try to minimize damage because it will be reused later. It may also be helpful to remove any holders forward or rearward of the axle to aid in positioning the lines once the upper bracket has been installed (fig. 3) .*
- *Attach the L-bracket (W) to the back frame brace using the 1/4" bolt (X), flat washers (Y) and nyloc nut (Z) supplied (fig. 2a). This L-bracket will eventually be used to attach the previously removed emissions line. Do not attach the line holder to it at this time.*

2. Upper bracket 07993 (E) goes onto the driver side frame rail (fig. 2a) and upper bracket 07148 (D) goes onto the passenger side frame rail (fig. 2b). Set the assemblies into position under the frame., above the axle, and insert the carriage bolt (G) through the exiting jounce bumper hole for both sides.

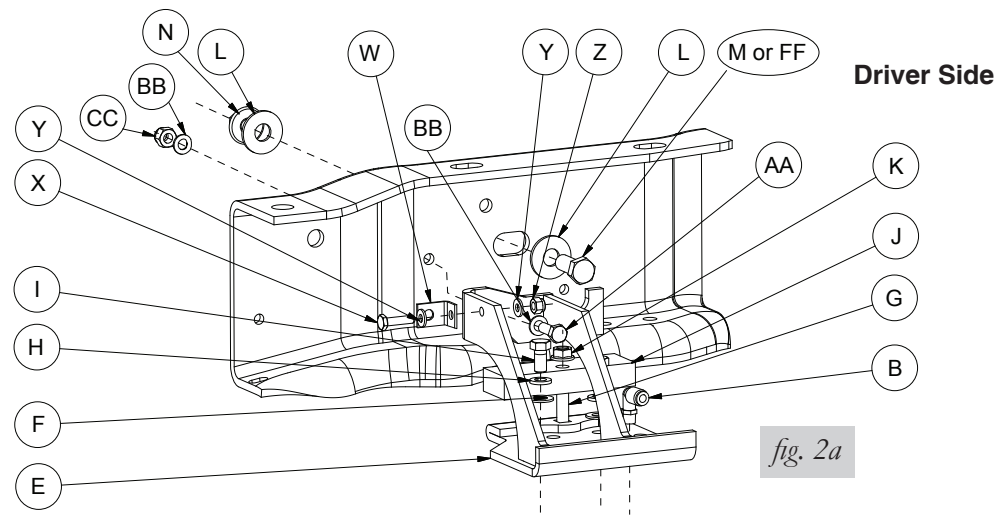

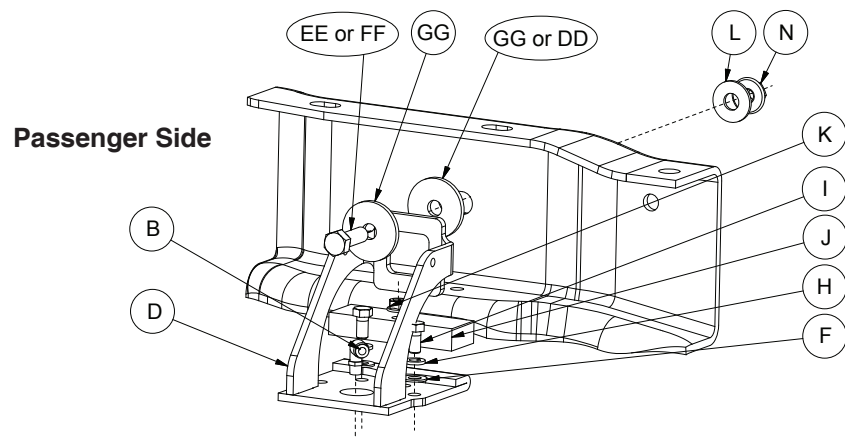

fig. 2b

If you have a fifth wheel hitch installed that has side plates along the frame, use the existing hardware removed. If not, use the 1/2" hardware supplied and recommended in this kit and in the directions in this manual.

* Use 3/4" flat washer (DD) if using 3/4" hitch hardware removed.

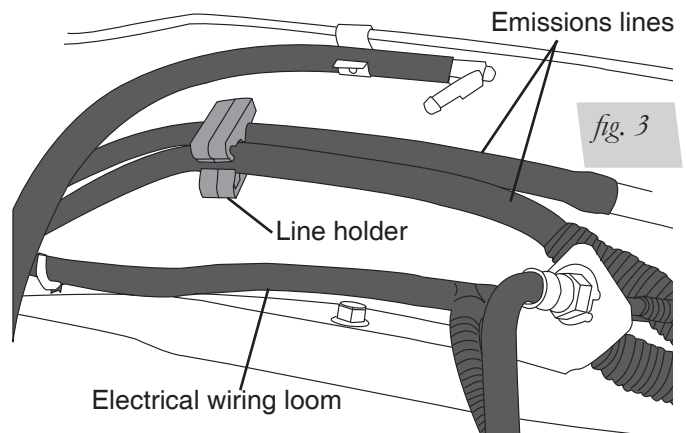

fig. 3

3. Cap with a 3/8" serrated flange lock nut (K) for both sides. Do not tighten at this time.

CAUTION

BE SURE NOT TO PINCH THE PREVIOUSLY MOVED WIRING OR LINES INSIDE THE LEFT FRAME RAIL.

NOTE

If you have a fifth wheel hitch with side plates and the model does not come with holes through the side bracket for attaching the kit to the frame, it will be necessary to drill a hole and use the 1/2" hardware supplied to attach the upper bracket to the frame.

- Push the upper bracket up and against the inside frame rail. Mark and center punch the 5th wheel bracket that is on the outside of the frame through the hole in the upper bracket and slot in the frame.
- Drill a 1/2" hole through the 5th wheel bracket.

LOWER BELLOWS AND BRACKET ASSEMBLY

1. Set a roll plate (C) over the top and bottom of the bellows (A) (fig. 1a or 1b).

NOTE

The radiused (rounded) edge of the roll plate (C) will be towards the bellows so that the bellows is seated inside both roll plates (fig. 1a or 1b).

2. Install the swivel elbow fitting (B) into the top of the bellows finger tight. Tighten the swivel fitting one and a half turns.

3. Insert one long carriage bolt (P) into the lower bracket (O) (fig. 4).

NOTE

This carriage bolt location will be behind the axle once the assembly is installed on the axle.

Insert long carriage bolt (P) in these holes in the lower bracket before assembling to bellows as noted.

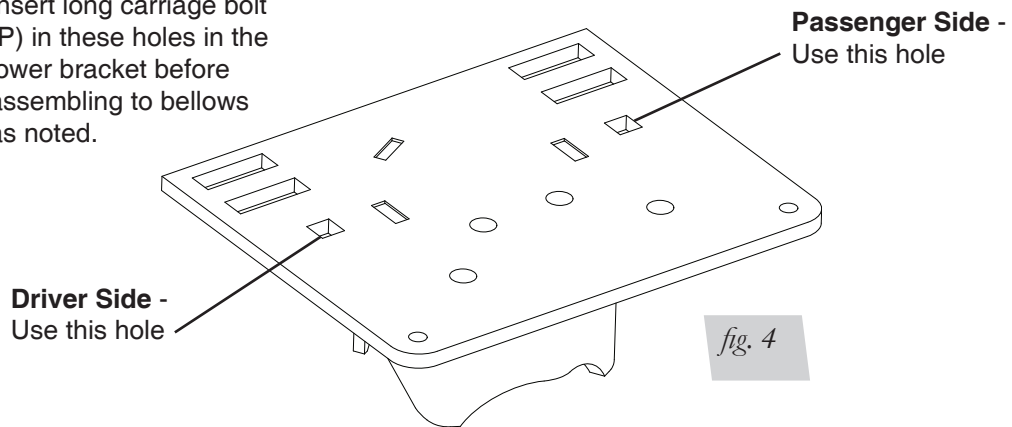

4. The lower bracket (O) has two sets of holes (fig. 5). Attach the bellows to the bracket using the 3/8" flat washers (F), lock washers (H) and 3/8"-24 x 7/8 bolts (I) using the corresponding holes designated. Tighten bolts securely.

NOTE

The insert for the fitting on top of the bellows points inward (refer to fig. 1a or fig. 1b).

Left (Driver) Side
mounting holes

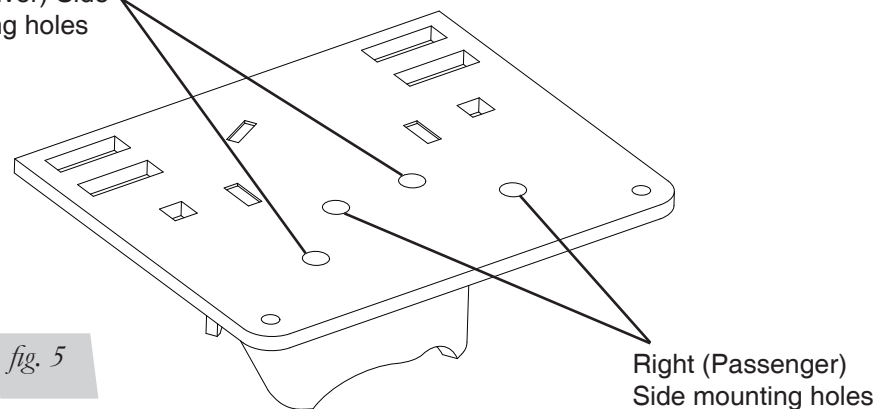

POSITIONING THE ASSEMBLY ON THE AXLE

NOTE

It may be necessary to support the frame and lower the axle to gain clearance for the air spring assembly.

1. Insert the left hand and right hand assembly on the axle under the frame.

NOTE

It may be necessary to raise the axle slightly to proceed with this part of the installation with paying close attention to inserting the elbow that was previously installed, through the upper bracket while raising the bellows into position.

2. Attach the bellows to the loose upper bracket using 3/8" flat washer (F), lock washers (H), and 3/8"-24 x 7/8" bolts (I). Using the corresponding holes in the upper bracket (fig. 6) tighten both mounting bolts securely.

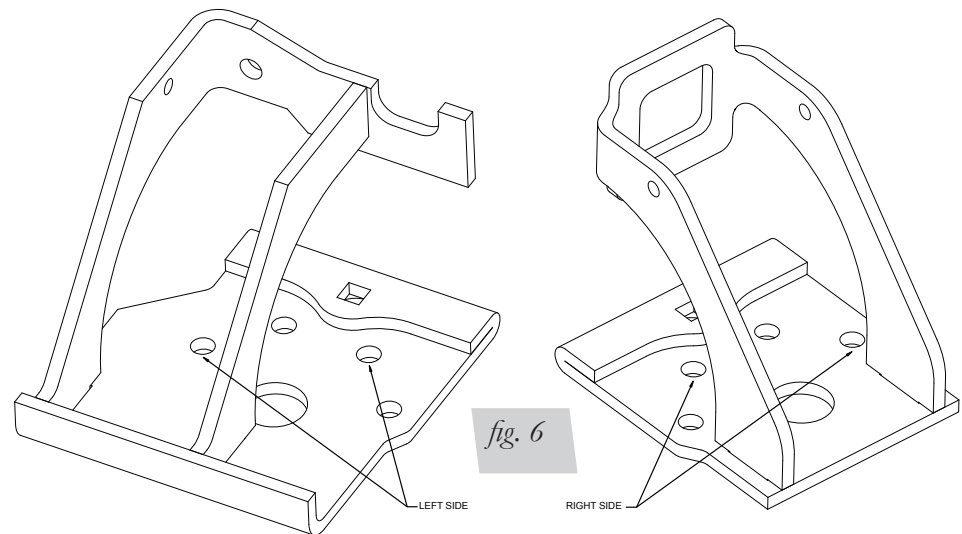

DRIVER SIDE UPPER BRACKET INSTALLATION

1. Insert the M8 bolt (AA) and M8 flat washer (BB) through the upper bracket, using the small hole in the rear of the brace, and through the frame. Cap with an M8 flat washer (BB) and M8 nyloc nut (CC) and leave loose at this time (fig. 1a).

NOTE

If you have a fifth wheel bracket on the side of the frame with no hole, it will be necessary to drill a hole through the plate for the M8 hardware.

2. With the bellows attached to the upper bracket, tighten the carriage bolt that goes through the upper bracket and into the frame (fig. 1a). Tighten the M8 bolt once the upper bracket is tight to the bottom of the frame.
3. Attach the upper bracket brace, through the half slot that is forward of the upper bracket (the frame has a slot in it under the upper brace at this location) by using the existing hardware from the fifth wheel bracket installation that was previously removed, or the 1/2-13 X 1.25" bolt (M) if you have the in bed hitch option from Ford, or the 1/2-13 X 3" bolt (if no fifth wheel or in bed hitch option was used) and a 1/2" flat washer (L). Insert the bolt and washer through the upper bracket and frame from the inside out and cap with a flat washer (L) and 1/2" serrated flange lock nut (N) (fig. 1a). Tighten securely.

CAUTION

BE SURE TO NOT PINCH THE WIRING HARNESS OR LINES INSIDE OF THE LEFT FRAME RAIL.

4. If so equipped with the emissions line previously loosened from the frame, insert the line holder post into the L-bracket (W) attached to the back brace of the upper bracket (E) (fig. 7). It may be necessary to move the line holder post forward or back on the lines to line up correctly with the L-bracket hole. Reattach any line holders removed forward or behind the axle, if possible, that were removed to aid in positioning the upper bracket.

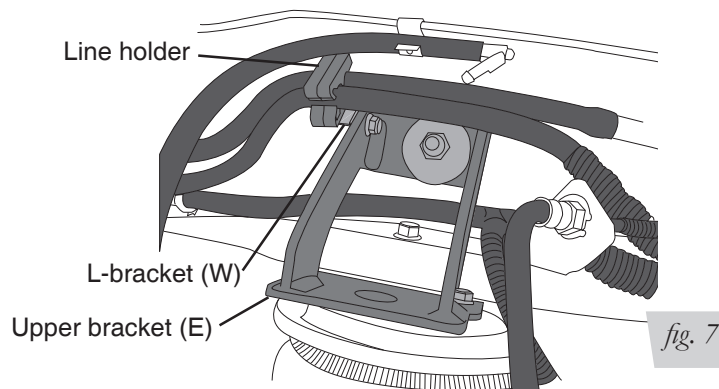

PASSENGER SIDE UPPER BRACKET INSTALLATION

1. With the bellows attached to the upper bracket, tighten the carriage bolt that goes through the upper bracket and into the frame (fig. 1b).
2. Insert a large 1/2" flat washer (GG) or 3/4" flat washer (DD) if using 3/4" existing fifth wheel hitch hardware, between the upper bracket and frame. It may be necessary to pry the upper bracket away from the frame slightly to make it easier to insert.
3. Attach the upper bracket brace by using the existing hardware from the fifth wheel bracket installation that was previously removed, or the 1/2-13 X 1.50" bolt (EE) if you have the in bed hitch option from Ford, or the 1/2-13 X 3" bolt (if no fifth wheel or in bed hitch option was used) and a large 1/2" flat washer (L). Insert the bolt and washer through the upper bracket, through the large washer between the bracket and frame from the inside out and cap with a flat washer (L) and 1/2" serrated flange lock nut (N) (fig. 2b). Tighten securely.

LOWER BRACKET ATTACHMENT

1. Insert a long 3/8" bolt (S) and flat washer (F) through the round hole of the four hole locating bracket (Q) (fig. 8).

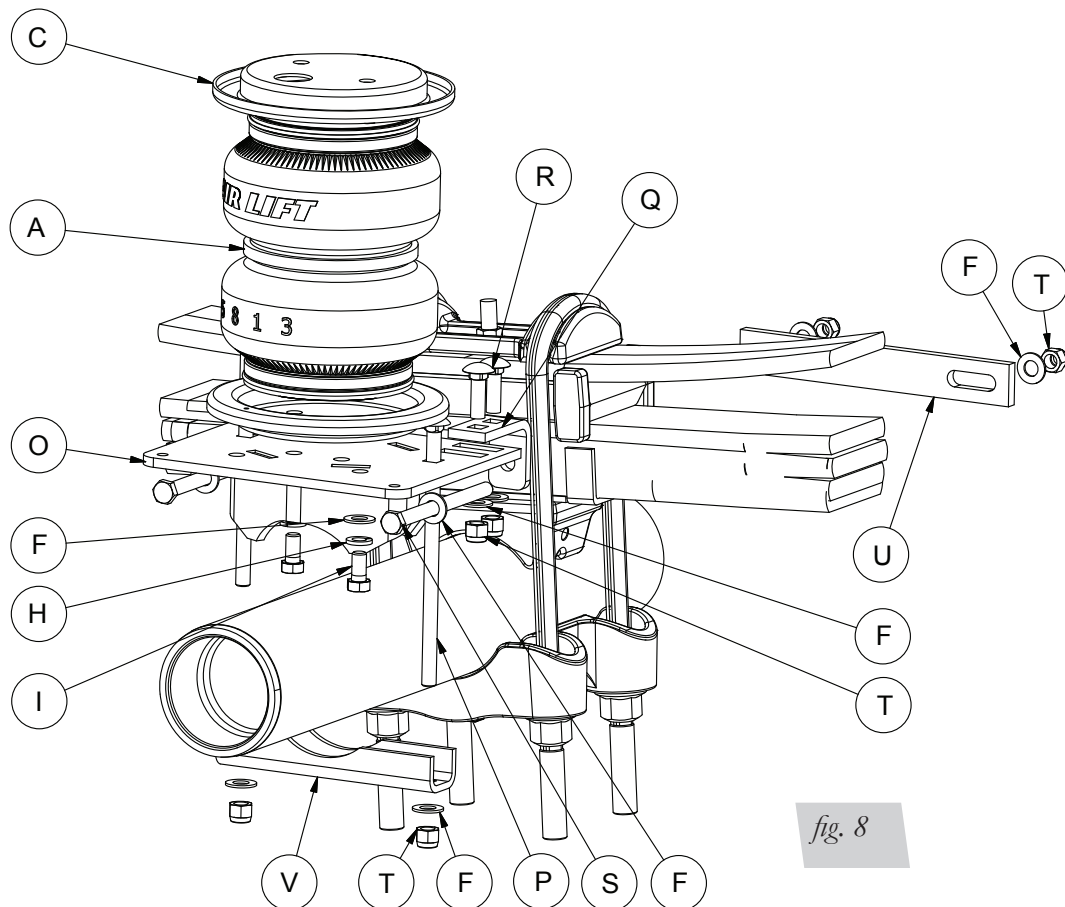

fig. 8

2. Attach the four hole locating bracket (Q) on the top of the lower bracket and through the slots, with two 3/8" carriage bolts (R), flat washers (F) and nylon lock nuts (T) (fig. 8). One goes forward and one goes behind the axle on the leaf spring side. Leave loose at this time.
3. Push the front and back four hole locating bracket against the stock u-bolts and tighten the short carriage bolts at this time.
4. Using the long 3/8" bolt (S) and flat washer (F) previously installed on the four hole locating bracket, insert them into the spring clamp bar (U) on the opposite side of the leaf spring assembly (fig. 8). Cap with 3/8" flat washer (F) and nyloc nut (T). Leave loose at this time.

NOTE

CAUTION

On some models it may be necessary to re-position a hard brake line on the back of the passenger side axle. This is necessary so that the line does not get pinched by the axle clamp that will be installed in step 5.

For models that have the line held in by a plastic clip on the shock/sway bar bracket, bend the wire brake line bracket (that is attached to the spring perch) up to create clearance between the brake line and the axle clamp (fig. 9).

For models that have a small steel tab holding the brake line to the axle, pry tab open enough so that the line can move, then bend the wire brake line bracket (that is attached to the spring perch) up to create clearance between the brake line and the axle clamp (fig. 10).



Axle clamp and hardware shown in this view

fig. 9

Bend wire brake line holder up to obtain more clearance between axle clamp and brake line



Bend small steel tab open to reposition brake line

fig. 10

5. Insert a long carriage bolt (P) through the remaining square hole in the lower bracket (forward of the axle) opposite of the one previously installed. Set the clamp bar (V) over the two carriage bolts and cap with two 3/8" flat washers (F) and two nyloc nuts (T).
6. Carefully draw the side hardware and axle hardware evenly. Torque the spring clamp bar bolts to 10 ft/lbs and the axle clamp bar bolts to 16 ft/lbs. Repeat for the opposite side. Trim the long carriage bolts below the nyloc nuts if necessary.

INSTALLING THE AIR LINES

1. Choose a convenient location for mounting the inflation valves. Popular locations for the inflation valve are:
 - a. The wheel well flanges
 - b. The license plate recess in bumper
 - c. Under the gas cap access door
 - d. Through the license plate

NOTE

Whatever the chosen location, make sure there is enough clearance around the inflation valves for an air chuck.

2. Drill two 5/16" holes to install the inflation valves.
3. Cut the air line assembly in two equal lengths.

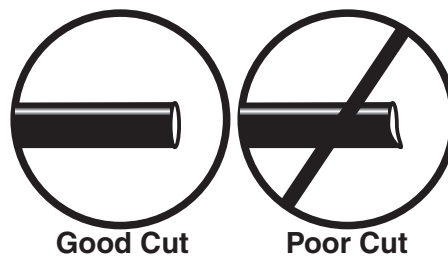

fig. 11

CAUTION

WHEN CUTTING OR TRIMMING THE AIR LINE, USE A HOSE CUTTER, A RAZOR BLADE, OR A SHARP KNIFE. A CLEAN, SQUARE CUT WILL ENSURE AGAINST LEAKS. DO NOT USE WIRE CUTTERS OR SCISSORS TO CUT THE AIR LINE. THESE TOOLS MAY FLATTEN OR CRIMP THE AIR LINE CAUSING IT TO LEAK AROUND THE O-RING SEAL INSIDE THE ELBOW FITTING (FIG. 11).

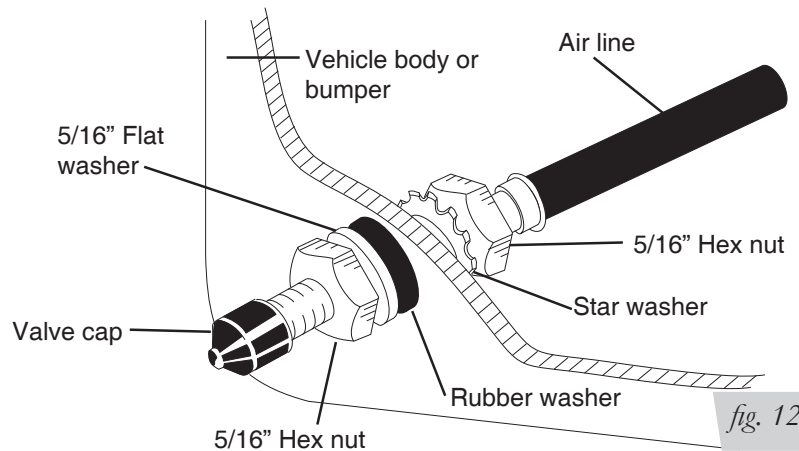

fig. 12

4. Place a 5/16" nut and star washer on the air valve. Leave enough of the inflation valve in front of the nut to extend through the hole and have room for the rubber washer, flat washer, and 5/16" nut and cap. There should be enough valve exposed after installation—approximately 1/2"—to easily apply a pressure gauge or an air chuck (fig. 12).

5. Push the inflation valve through the hole and use the rubber washer, flat washer, and another 5/16" nut to secure it in place. Tighten the nuts to secure the assembly.
6. Route the air line along the frame to the air fitting on the air spring (fig. 13). Keep AT LEAST 6" of clearance between the air line and heat sources, such as the exhaust pipes, muffler, or catalytic converter. Avoid sharp bends and edges. Use the plastic tie straps to secure the air line to fixed, non-moving points along the chassis. Be sure that the tie straps are tight, but do not pinch the air line. Leave at least 2" of slack to allow for any movement that might pull on the air line.

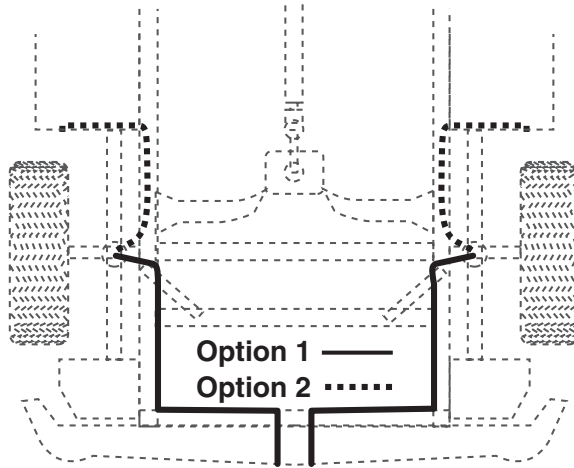

fig. 13

7. Cut off the air line, leaving approximately 12" of extra air line. A clean square cut will ensure against leaks. Insert the air line into the air fitting. This is a push-to-connect fitting. Simply push the air line into the 90° swivel fitting until it bottoms out (9/16" of air line should be in the fitting).

INSTALLING THE HEAT SHIELD

1. Bend tabs to provide a 1/2" dead air space between exhaust pipe and heat shield (fig. 14).
2. Attach the heat shield to the exhaust pipe using the clamps. Bend the heat shield for maximum clearance to the air spring (fig. 14a).

NOTE

Some vehicles have large resonators in this area, it will be necessary to double up on the clamps to fit these models (fig. 14b).

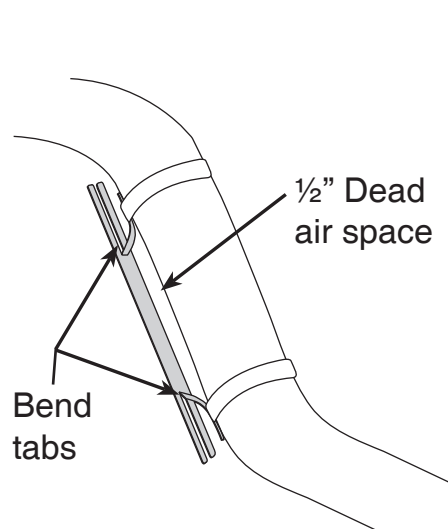

fig. 14a

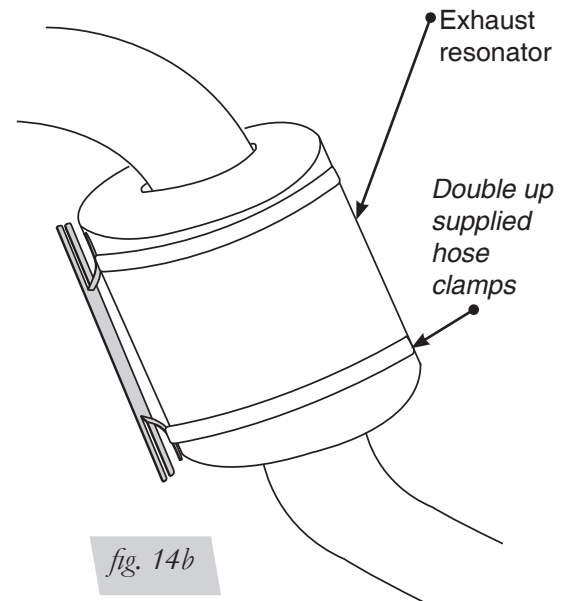

fig. 14b

CHECKING FOR LEAKS

1. Inflate the air spring to 30 PSI.
2. Spray all connections and the inflation valves with a solution of 1/5 liquid dish soap and 4/5 water. Spot leaks easily by looking for bubbles in the soapy water.
3. After the test, deflate the springs to the minimum pressure required to restore the system to normal ride height. Do not deflate to lower than 5 PSI.
4. Check the air pressure again after 24 hours. A 2 - 4 PSI loss after initial installation is normal. Retest for leaks if the loss is more than 5 lbs.

FIXING LEAKS

1. If there is a problem with the swivel fitting:
 - a. Check the air line connection by deflating the spring and removing the line by pulling the collar against the fitting and pulling firmly on the air line. Trim 1" off the end of the air line. Be sure the cut is clean and square (see fig. 11). Reinsert the air line into the push-to-connect fitting.
 - b. Check the threaded connection by tightening the swivel fitting another ½ turn. If it still leaks, deflate the air spring, remove the fitting, and re-coat the threads with thread sealant. Reinstall by hand tightening as much as possible and then use a wrench for an additional two turns.
2. If there is a problem with the inflation valve:
 - a. Check the valve core by tightening it with a valve core tool.
 - b. Check the air line by removing the air line from the barbed type fitting. Cut the air line off a few inches in front of the fitting and use a pair of pliers or vice grips to pull/twist the air line off of the fitting.

 **CAUTION**

DO NOT CUT OFF THE AIR LINE COMPLETELY AS THIS WILL USUALLY NICK THE BARB AND RENDER THE FITTING USELESS.

3. If the preceding steps have not resolved the problem, call Air Lift customer service at (800) 248-0892.

Before Operating

INSTALLATION CHECKLIST (To be completed by installer)

- Clearance test — Inflate the air springs to 60 PSI and ensure there is at least ½” clearance around each bellow, away from anything that might rub against them. Be sure to check the tire, brake drum, frame, shock absorbers and brake cables.
- Leak test before road test — Inflate the air springs to 60 PSI, check all connections for leaks with a soapy water solution. See page 14 for tips on how to spot leaks. All leaks must be eliminated before the vehicle is road tested.
- Heat test — Be sure there is sufficient clearance from any heat sources — at least 6” for air springs and air lines. If a heat shield was included in the kit, install it. If there is no heat shield, but one is required, call (800) 248-0892.
- Fastener test — Recheck all bolts for proper torque. Axle clamp bar carriage bolt lock nuts should be torqued to 16 ft/lbs. Re-torque after 100 miles.
- Road test — The vehicle should be road tested after the preceding tests. Inflate the air springs to 25 PSI (50 PSI if the vehicle is loaded). Drive the vehicle 10 miles and recheck for clearance, loose fasteners and air leaks.
- Operating instructions — If professionally installed, the installer should review the Product Use, Maintenance and Servicing section on page 15 with the owner. Be sure to provide the owner with all of the paperwork which came with the kit.

Technician’s Signature _____

Date _____

POST-INSTALLATION CHECKLIST

- Overnight leak down test — Recheck air pressure after the vehicle has been used for 24 hours. If the pressure has dropped more than 5 PSI, then there is a leak that must be fixed. Either fix the leak yourself or return to the installer for service.
- Air pressure requirements — I understand the air pressure requirements of my air spring system. Regardless of load, the air pressure should always be adjusted to maintain ride height at all times.
- Thirty day or 500 mile test — I understand that I must recheck the air spring system after 30 days or 500 miles, whichever comes first. If any part shows signs of rubbing or abrasion, the source should be identified and moved, if possible. If it is not possible to relocate the cause of the abrasion, the air spring may need to be remounted. If professionally installed, the installer should be consulted. Check all fasteners for tightness.

Product Use, Maintenance and Servicing

Suggested Driving Pressure	Maximum Air Pressure
5 PSI	100 PSI
FAILURE TO MAINTAIN CORRECT MINIMUM PRESSURE (OR PRESSURE PROPORTIONAL TO LOAD), BOTTOMING OUT, OVER-EXTENSION OR RUBBING AGAINST ANOTHER COMPONENT WILL VOID THE WARRANTY.	

MAINTENANCE GUIDELINES

NOTE

By following the steps below, vehicle owners will obtain the longest life and best results from their air springs.

1. Check the air pressure weekly.
2. Always maintain normal ride height. Never inflate beyond 100 PSI.
3. If you develop an air leak in the system, use a soapy water solution (1/5 liquid dish soap and 4/5 water) to check all air line connections and the inflation valve core before deflating and removing the air spring.

CAUTION

FOR YOUR SAFETY AND TO PREVENT POSSIBLE DAMAGE TO YOUR VEHICLE, DO NOT EXCEED MAXIMUM GROSS VEHICLE WEIGHT RATING (GVWR), AS INDICATED BY THE VEHICLE MANUFACTURER. ALTHOUGH YOUR AIR SPRINGS ARE RATED AT A MAXIMUM INFLATION PRESSURE OF 100 P.S.I., THE AIR PRESSURE ACTUALLY NEEDED IS DEPENDANT ON YOUR LOAD AND GVWR.

4. Loaded vehicles require at least 25 PSI or more. A “loaded vehicle” refers to a vehicle with a heavy bed load, a trailer, or both. As discussed above, never exceed GVWR, regardless of air spring, air pressure, or other load assist. The springs in this kit will support approximately 40 lbs. of load (combined on both springs) for each 1 PSI of pressure. The required air pressure will vary depending on the state of the original suspension. Operating the vehicle below the minimum air spring pressure will void the Air Lift warranty.
5. When increasing load, always adjust the air pressure to maintain the normal ride height. Increase or decrease pressure from the system as necessary to attain normal ride height for optimal ride and handling. Remember that loads carried behind the axle (including tongue loads) require more leveling force (pressure) than those carried directly over the axle.
6. Always add air to springs in small quantities, checking the pressure frequently.
7. Should it become necessary to raise the vehicle by the frame, make sure the system is at minimum pressure (5 PSI) to reduce the tension on the suspension/brake components. Use of on board leveling systems do not require deflation or disconnection.
8. Periodically check the air spring system fasteners for tightness. Also, check the air springs for any signs of rubbing. Realign if necessary.
9. On occasion, give the air springs a hard spray with a garden hose in order to remove mud, sand, gravel or other abrasive debris.

Troubleshooting Guide

1. Leak test the air line connections, the threaded connection into the air spring, and all fittings in the control system.
2. Inspect the air lines to be sure none are pinched. Tie straps may be too tight. Loosen or replace the strap and replace leaking components.
3. Inspect the air line for holes and cracks. Replace as needed.
4. Look for a kink or fold in the air line. Reroute as needed.

If the preceding steps do not solve the problem, it is possibly caused by a failed air spring — either a factory defect or an operating problem. Please call Air Lift at (800) 248-0892 for assistance.

Frequently Asked Questions

Q. Will installing air springs increase the weight ratings of a vehicle?

No. Adding air springs will not change the weight ratings (GAWR, GCWR and/or GVWR) of a vehicle. Exceeding the GVWR is dangerous and voids the Air Lift warranty.

Q. Is it necessary to keep air in the air springs at all times and how much pressure will they need?

The minimum air pressure should be maintained at all times. The minimum air pressure keeps the air spring in shape, ensuring that it will move throughout its travel without rubbing or wearing on itself.

Q. Is it necessary to add a compressor system to the air springs?

No. Air pressure can be adjusted with any type of compressor as long as it can produce sufficient pressure to service the springs. Even a bicycle tire pump can be used, but it's a lot of work.

Q. How long should air springs last?

If the air springs are properly installed and maintained they can last indefinitely.

Q. Will raising the vehicle on a hoist for service work damage the air springs?

No. The vehicle can be lifted on a hoist for short-term service work such as tire rotation or oil changes. However, if the vehicle will be on the hoist for a prolonged period of time, support the axle with jack stands in order to take the tension off of the air springs.

Tuning the Air Pressure

Pressure determination comes down to three things — level vehicle, ride comfort, and stability.

1. Level vehicle

If the vehicle's headlights are shining into the trees or the vehicle is leaning to one side, then it is not level (fig. 15). Raise the air pressure to correct either of these problems and level the vehicle.

2. Ride comfort

If the vehicle has a rough or harsh ride it may be due to either too much pressure or not enough (fig. 16). Try different pressures to determine the best ride comfort.

3. Stability

Stability translates into safety and should be the priority, meaning the driver may need to sacrifice a perfectly level and comfortable ride. Stability issues include roll control, bounce, dive during braking and sponginess (fig. 17). Tuning out these problems usually requires an increase in pressure.



Sway and body roll

Guidelines for Adding Air

1. Start with the vehicle level or slightly above.
2. When in doubt, always add air.
3. For motorhomes, start with 50-100 PSI in the rear because it can be safely assumed that it is heavily loaded.
4. If the front of the vehicle dives while braking, increase the pressure in the front air bags, if equipped.
5. If it is ever suspected that the air bags have bottomed out, increase the pressure (fig. 18).
6. Adjust the pressure up and down to find the best ride.
7. If the vehicle rocks and rolls, adjust the air pressure to reduce movement.
8. It may be necessary to maintain different pressures on each side of the vehicle. Loads such as water, fuel, and appliances will cause the vehicle to be heavier on one side (fig. 19). As much as a 50 PSI difference is not uncommon.



Bottoming out

fig. 18

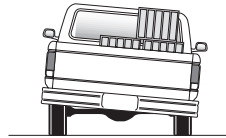

Unlevel

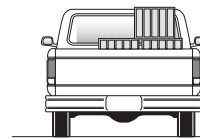

Level

fig. 19



Warranty and Returns Policy

Air Lift Company warrants its products, for the time periods listed below, to the original retail purchaser against manufacturing defects when used on catalog-listed applications on cars, vans, light trucks and motorhomes under normal operating conditions for as long as Air Lift manufactures the product. The warranty does not apply to products that have been improperly applied, improperly installed, used in racing or off-road applications, used for commercial purposes, or which have not been maintained in accordance with installation instructions furnished with all products. The consumer will be responsible for removing (labor charges) the defective product from the vehicle and returning it, transportation costs prepaid, to the dealer from which it was purchased or to Air Lift Company for verification.

Air Lift will repair or replace, at its option, defective products or components. A minimum \$10.00 shipping and handling charge will apply to all warranty claims. Before returning any defective product, you must call Air Lift at (800) 248-0892 in the U.S. and Canada (elsewhere, (517) 322-2144) for a Returned Materials Authorization (RMA) number. Returns to Air Lift can be sent to: Air Lift Company • 2727 Snow Road • Lansing, MI • 48917.

Product failures resulting from abnormal use or misuse are excluded from this warranty. The loss of use of the product, loss of time, inconvenience, commercial loss or consequential damages is not covered. The consumer is responsible for installation/reinstallation (labor charges) of the product. Air Lift Company reserves the right to change the design of any product without assuming any obligation to modify any product previously manufactured.

This warranty gives you specific legal rights and you may also have other rights that vary from state-to-state. Some states do not allow limitations on how long an implied warranty lasts or allow the exclusion or limitation of incidental or consequential damages. The above limitation or exclusion may not apply to you. There are no warranties, expressed or implied including any implied warranties of merchantability and fitness, which extend beyond this warranty period. There are no warranties that extend beyond the description on the face hereof. Seller disclaims the implied warranty of merchantability. (Dated proof of purchase required.)

Air Lift 1000	Lifetime Limited	Load Controller (I)	2 Year Limited
RideControl	Lifetime Limited	Load Controller (II)	2 Year Limited
SlamAir	Lifetime Limited	SmartAir	2 Year Limited
LoadLifter 5000*	Lifetime Limited	Wireless AIR	2 Year Limited
Lifestyle**	1 Year Limited	Other Accessories	2 Year Limited

**formerly SuperDuty*
***formerly EasyStreet*

Replacement Parts and Returns



Please do not cannibalize kits for parts!

Help us avoid waste and order by part number. If you need an air spring replacement part, please follow these steps.

Step 1 Contact your dealer and order by part number. Download a detailed list at www.airliftcompany.com/downloads.html.

Step 2 If your dealer does not have the part in stock, call Air Lift directly and we can ship you the part you need, the same day, in the U.S. or Canada.

Missing or damaged item?

Before calling Air Lift customer service, please gather the following information:

- Your receipt
- Condition the kit was in when you purchased it
- Description or part number of the missing/damaged item
- Information from the box label
 1. Kit number
 2. Weight
 3. When was the kit packed?

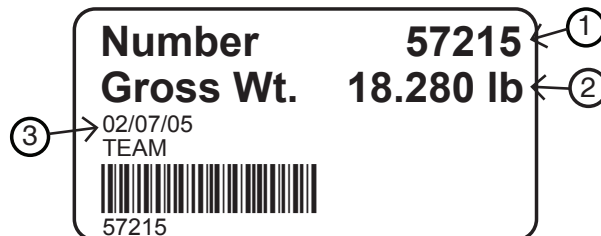

Replacement Information

If you need replacement parts, contact the local dealer or call Air Lift customer service at (800) 248-0892. Most parts are immediately available and can be shipped the same day.

Contact Air Lift Company customer service at (800) 248-0892 first if:

- Parts are missing from the kit.
- Need technical assistance on installation or operation.
- Broken or defective parts in the kit.
- Wrong parts in the kit.
- Have a warranty claim or question.

Contact the retailer where the kit was purchased:

- If it is necessary to return or exchange the kit for any reason.
- If there is a problem with shipping if shipped from the retailer.
- If there is a problem with the price.

Contact Information

If you have any questions, comments or need technical assistance contact our customer service department by calling (800) 248-0892, Monday through Friday, 8 a.m. to 7 p.m. Eastern Time. For calls from outside the USA or Canada, our local number is (517) 322-2144.

For inquiries by mail, our address is PO Box 80167, Lansing, MI 48908-0167. Our shipping address for returns is 2727 Snow Road, Lansing, MI 48917.

You may also contact us anytime by e-mail at sales@airliftcompany.com or on the web at www.airliftcompany.com.



*Thank you for purchasing
Air Lift products!*

We're delighted to be a part of your air suspension solution. Air Lift Company is dedicated to ensuring that you have the best possible experience with our products. If you have any questions, concerns or even a suggestion, please feel free to contact us. Our customer service representatives are here for you Monday through Friday, 8 a.m. to 7 p.m. Eastern Time. Need help sooner than that? Check out the wealth of information that we have online for you at www.airliftcompany.com.

It's easy to put your air springs to work with an Air Lift on board air compressor system!

Air Lift offers the most advanced compressor systems in the industry. Choose the best option for your ride from many models and features! WirelessAIR model pictured to the right.



Which compressor system is right for your vehicle?

xx= Best choice
x = Good choice

**Four air springs require TWO compressor systems.*

What type of vehicle are you driving?	Wireless AIR	SmartAir		Load Controller II		Load Controller I	
		SINGLE	DUAL	SINGLE	DUAL	SINGLE	DUAL
Pickup with any towable	xx	x		x		x	
Pickup with a truck camper	xx				x		x
Van/SUV/CUV towing or heavy load	xx	x		x		x	
Car with rear coil air springs	xx			x		x	
Motorhome with rear air springs*	xx		x		x		x
All others	xx	x		x		x	

Save time and money! Register your warranty online today at www.airliftcompany.com/warrantyreg.htm

Need Help?

Contact our customer service department by calling (800) 248-0892, Monday through Friday, 8 a.m. to 7 p.m. Eastern Time. For calls from outside the USA or Canada, our local number is (517) 322-2144.

**Register your warranty online at
www.airliftcompany.com/warranty**



Thank you for purchasing Air Lift products — the professional installer's choice!

Air Lift Company • 2727 Snow Road • Lansing, MI 48917 or PO Box 80167 • Lansing, MI 48908-0167
Toll Free (800) 248-0892 • Local (517) 322-2144 • Fax (517) 322-0240 • www.airliftcompany.com

Printed in
the USA