

SC-207X Series

User Manual

General-Purpose Termination Breadboards

November 1995 Edition

Part Number 371173A-01

**© Copyright 1991, 1995 National Instruments Corporation.
All Rights Reserved.**

National Instruments Corporate Headquarters

6504 Bridge Point Parkway

Austin, TX 78730-5039

(512) 794-0100

Technical support fax: (800) 328-2203

(512) 794-5678

Branch Offices:

Australia 03 9 879 9422, Austria 0662 45 79 90 0, Belgium 02 757 00 20, Canada (Ontario) 519 622 9310,

Canada (Québec) 514 694 8521, Denmark 45 76 26 00, Finland 90 527 2321, France 1 48 14 24 24,

Germany 089 741 31 30, Hong Kong 2645 3186, Italy 02 48301892, Japan 03 5472 2970, Korea 02 596 7456,

Mexico 95 800 010 0793, Netherlands 0348 433466, Norway 32 84 84 00, Singapore 2265886, Spain 91 640 0085,

Sweden 08 730 49 70, Switzerland 056 200 51 51, Taiwan 02 377 1200, U.K. 01635 523545

Limited Warranty

The SC-207X Series boards are warranted against defects in materials and workmanship for a period of one year from the date of shipment, as evidenced by receipts or other documentation. National Instruments will, at its option, repair or replace equipment that proves to be defective during the warranty period. This warranty includes parts and labor.

A Return Material Authorization (RMA) number must be obtained from the factory and clearly marked on the outside of the package before any equipment will be accepted for warranty work. National Instruments will pay the shipping costs of returning to the owner parts which are covered by warranty.

National Instruments believes that the information in this manual is accurate. The document has been carefully reviewed for technical accuracy. In the event that technical or typographical errors exist, National Instruments reserves the right to make changes to subsequent editions of this document without prior notice to holders of this edition. The reader should consult National Instruments if errors are suspected. In no event shall National Instruments be liable for any damages arising out of or related to this document or the information contained in it.

EXCEPT AS SPECIFIED HEREIN, NATIONAL INSTRUMENTS MAKES NO WARRANTIES, EXPRESS OR IMPLIED, AND SPECIFICALLY DISCLAIMS ANY WARRANTY OF MERCHANTABILITY OR FITNESS FOR A PARTICULAR PURPOSE. CUSTOMER'S RIGHT TO RECOVER DAMAGES CAUSED BY FAULT OR NEGLIGENCE ON THE PART OF NATIONAL INSTRUMENTS SHALL BE LIMITED TO THE AMOUNT THEREFORE PAID BY THE CUSTOMER. NATIONAL INSTRUMENTS WILL NOT BE LIABLE FOR DAMAGES RESULTING FROM LOSS OF DATA, PROFITS, USE OF PRODUCTS, OR INCIDENTAL OR CONSEQUENTIAL DAMAGES, EVEN IF ADVISED OF THE POSSIBILITY THEREOF. This limitation of the liability of National Instruments will apply regardless of the form of action, whether in contract or tort, including negligence. Any action against National Instrument must be brought within one year after the cause of action accrues. National Instruments shall not be liable for any delay in performance due to causes beyond its reasonable control. The warranty provided herein does not cover damages, defects, malfunctions, or service failures caused by owner's failure to follow the National Instruments installation, operation, or maintenance instructions; owner's modification of the product; owner's abuse, misuse, or negligent acts; and power failure or surges, fire, flood, accident, actions of third parties, or other events outside reasonable control.

Copyright

Under the copyright laws, this publication may not be reproduced or transmitted in any form, electronic or mechanical, including photocopying, recording, storing in an information retrieval system, or translating, in whole or in part, without the prior written consent of National Instruments Corporation.

Trademarks

NI-DAQ[®] is a trademark of National Instruments Corporation.

Product and company names listed are trademarks or trade names of their respective companies.

WARNING REGARDING MEDICAL AND CLINICAL USE OF NATIONAL INSTRUMENTS PRODUCTS

National Instruments products are not designed with components and testing intended to ensure a level of reliability suitable for use in treatment and diagnosis of humans. Applications of National Instruments products involving medical or clinical treatment can create a potential for accidental injury caused by product failure, or by errors on the part of the user or application designer. Any use or application of National Instruments products for or involving medical or clinical treatment must be performed by properly trained and qualified medical personnel, and all traditional medical safeguards, equipment, and procedures that are appropriate in the particular situation to prevent serious injury or death should always continue to be used when National Instruments products are being used. National Instruments products are NOT intended to be a substitute for any form of established process, procedure, or equipment used to monitor or safeguard human health and safety in medical or clinical treatment.

Contents

About This Manual	xi
Organization of This Manual	xi
Conventions Used in This Manual.....	xii
Related Documentation.....	xii
Customer Communication	xiii

Chapter 1

Introduction	1-1
About the SC-207X Series Boards.....	1-1
What You Need to Get Started	1-4
Optional Equipment	1-4
Software	1-4
Unpacking.....	1-5

Chapter 2

SC-2070 Board	2-1
Analog Input	2-2
Temperature Sensor	2-3
Shield Ground	2-4
Fuse and Power LED	2-4
Digital and Timing Signals	2-4
Board-to-Board Cabling.....	2-5
Mounting.....	2-6
Applications	2-6
Soldering and Desoldering on the SC-2070 Board.....	2-7
Channel Configurations	2-7
Connecting Nonreferenced or Floating Signal Sources.....	2-7
Differential Inputs.....	2-7
Single-Ended Inputs.....	2-8
Connecting Ground-Referenced Signal Sources.....	2-9
Differential Inputs.....	2-9
Single-Ended Inputs.....	2-9
Building Lowpass Filters	2-10
Building Highpass Filters.....	2-13
Building Attenuators (Voltage Dividers).....	2-15
Working with Thermocouples	2-17
Using the SC-2070 Board for Thermocouple Measurements.....	2-17
Input Filtering and Broken Thermocouple Detection (Optional)	2-18
Selecting the Gain and Input Ranges	2-19
Linearizing the Data.....	2-20

Differential Measurements.....	2-22
An Example of Using Thermocouples in Differential Mode.....	2-22
Single-Ended Measurements.....	2-23
An Example of Using Thermocouples in Single-Ended Mode.....	2-23
Sources of Error	2-24
Thermocouple Measurement Accuracies.....	2-25
Additional Signal Connection Information.....	2-25

Chapter 3

SC-2071 Board	3-1
Analog Input	3-2
Temperature Sensor	3-4
Shield Ground	3-4
Fuse and Power LED	3-4
Digital and Timing Signals	3-5
Board-to-Board Cabling.....	3-5
Mounting.....	3-7
Applications	3-7
Soldering and Desoldering on the SC-2071 Board.....	3-7
Connecting Floating Signal Sources	3-8
Connecting Grounded Signal Sources	3-8
Building Lowpass Filters	3-8
Building Highpass Filters.....	3-10
Building Attenuators (Voltage Dividers).....	3-12
Working with Thermocouples	3-14
Using the SC-2071 Board for Thermocouple Measurements.....	3-15
Input Filtering and Broken Thermocouple Detection (Optional)	3-15
Selecting the Gain and Input Ranges	3-16
Linearizing the Data.....	3-17
Measurement Connections.....	3-18
An Example of Using Thermocouples.....	3-19
Sources of Error	3-19
Thermocouple Measurement Accuracies.....	3-20
Additional Signal Connection Information.....	3-21

Chapter 4

SC-2072 Board	4-1
Signal Connections	4-3
Power Connections	4-4
Fuses and Power LED.....	4-5
Board-to-Board Cabling.....	4-6
Mounting.....	4-7
Soldering and Desoldering on the SC-2072 Board.....	4-7

Chapter 5

Installation and Connections 5-1

 Hardware Installation..... 5-1

 Hardware Installation for the SC-2070 and the SC-2071 5-1

 Hardware Installation for the SC-2072 5-2

 Installing the SC-205X Series Cable Adapter Boards 5-2

 Installing the BNC-2081 Analog Breakout Board..... 5-3

 Rack Mounting..... 5-3

 External Power Connection (If Necessary)..... 5-4

 SC-207X Series Board Connection..... 5-7

 Signal Connections 5-8

 Ribbon Cable Connectors 5-8

 Screw Terminal Connections for the SC-2070 and the SC-2071 5-8

 Screw Terminal Connections for the SC-2072 5-9

 Rack-Mount Chassis Cover Attachment..... 5-9

Appendix A

Specifications A-1

Appendix B

Customer Communication..... B-1

Glossary..... Glossary-1

Index..... Index-1

Figures

Figure 1-1.	SC-2070 Board Connected Directly to an MIO-16 Board.....	1-3
Figure 1-2.	SC-207X Series Board, SC-206X Series Board, and SC-205X Series Board Connected to an MIO-16 Board.....	1-3
Figure 2-1.	SC-2070 Board Parts Locator Diagram	2-2
Figure 2-2.	Onboard Equivalent Circuit	2-3
Figure 2-3.	W1 Jumper Settings	2-4
Figure 2-4.	W2 Jumper Settings	2-4
Figure 2-5.	Direct Connection between an MIO-16 Board and the SC-2070 Board	2-5
Figure 2-6.	Connection between an MIO-16 Board and the SC-2070 Board via the SC-2050 Board.....	2-6
Figure 2-7.	Bias Return Resistor for DC-Coupled Floating Source on Channel 1.....	2-8
Figure 2-8.	Normalized Frequency Response of Lowpass Filter	2-10
Figure 2-9.	Lowpass Filter on Differential Channel 1.....	2-12
Figure 2-10.	Normalized Frequency Response of Highpass Filter.....	2-13
Figure 2-11.	Highpass Filter on Differential Channel 1	2-14
Figure 2-12.	Attenuator for Use with Differential Inputs.....	2-16
Figure 2-13.	Thermocouple Circuit with Open Thermocouple Detect and Lowpass Noise Filter.....	2-19
Figure 3-1.	SC-2071 Board Parts Locator Diagram	3-2
Figure 3-2.	Onboard Equivalent Circuit	3-3
Figure 3-3.	W1 Jumper Settings	3-4
Figure 3-4.	W2 Jumper Settings	3-4
Figure 3-5.	Direct Connection between a Lab/1200 Device and the SC-2071 Board.....	3-5
Figure 3-6.	Daisy-chaining a Lab/1200 Device to a BNC-2081	3-6
Figure 3-7.	Connection between a Lab/1200 Device and the SC-2071 Board via the SC-2053 Board.....	3-6
Figure 3-8.	Normalized Frequency Response of Lowpass Filter	3-9
Figure 3-9.	Lowpass Filter on Channel 1	3-10
Figure 3-10.	Normalized Frequency Response of Highpass Filter.....	3-11
Figure 3-11.	Highpass Filter on Channel 1.....	3-12
Figure 3-12.	Attenuator for Use with SC-2071 Board Inputs.....	3-13
Figure 3-13.	Thermocouple Circuit with Open Thermocouple Detect and Lowpass Noise Filter.....	3-16
Figure 4-1.	SC-2072 Board Parts Locator Diagram	4-2
Figure 4-2.	SC-2072D Board Parts Locator Diagram	4-3
Figure 4-3.	Direct Connection between a TIO-10 Board and the SC-2072 Board.....	4-6
Figure 4-4.	Connection between a DIO-24 Board and the SC-2072 Board via the SC-2051 Board.....	4-6
Figure 5-1.	Mounting Locations for SC-207X Series Boards	5-3
Figure 5-2.	Attaching a Mountable Board to the Chassis.....	5-3
Figure 5-3.	Double-Height Mounting.....	5-4
Figure 5-4.	Connections Between DAQ Devices and SC-205X Series Boards and Between SC-205X Series Boards and SC-2070 and SC-2071 Boards	5-7

Tables

Table 1-1.	DAQ Devices for Use with SC-207X Series Boards.....	1-2
Table 2-1.	Component Positions in Each Channel.....	2-3
Table 2-2.	DAQ Boards Used with the SC-2070 Board	2-5
Table 2-3.	Thermocouple Voltage Output Extremes (mV).....	2-20
Table 2-4.	NBS Polynomial Coefficients.....	2-21
Table 2-5.	Thermocouple Measurement Accuracies.....	2-25
Table 3-1.	Component Positions in Each Channel.....	3-3
Table 3-2.	DAQ Devices Used with the SC-2071 Board.....	3-5
Table 3-3.	Thermocouple Voltage Output Extremes (mV).....	3-17
Table 3-4.	NBS Polynomial Coefficients.....	3-18
Table 3-5.	Thermocouple Measurement Accuracies.....	3-21
Table 4-1.	Switch S2 Settings for National Instruments DAQ Devices.....	4-4
Table 5-1.	Amount of Power Supplied by DAQ Devices	5-6
Table 5-2.	SC-205X Series Board Connectors Compatible with the SC-207X Series Boards.....	5-8

About This Manual

This manual describes the mechanical and electrical aspects of the SC-2070, SC-2071, and SC-2072 boards and contains information about installing and making connections to the boards. The SC-207X Series boards are general-purpose termination breadboards. These breadboards connect to the National Instruments multifunction data acquisition (DAQ) boards for the IBM PC/XT/AT, Personal System/2, and compatible computers, and Macintosh II computers.

Each of the SC-207X Series boards is described in detail in this manual.

Organization of This Manual

The *SC-207X Series User Manual* is organized as follows:

- Chapter 1, *Introduction*, describes the SC-207X Series boards, lists what you need to get started, describes the optional equipment and software, and explains how to unpack your SC-207X Series board.
- Chapter 2, *SC-2070 Board*, describes the SC-2070 board in detail, including function, compatibility, connection, mounting, and applications. This chapter also discusses working with thermocouples.
- Chapter 3, *SC-2071 Board*, describes the SC-2071 board in detail, including function, compatibility, connection, mounting, and applications. This chapter also discusses working with thermocouples.
- Chapter 4, *SC-2072 Board*, describes the SC-2072 board in detail, including function, connection, mounting, and soldering/desoldering.
- Chapter 5, *Installation and Connections*, explains how to install and make connections to the SC-207X Series boards.
- Appendix A, *Specifications*, contains specifications for the SC-207X Series boards.
- Appendix B, *Customer Communication*, contains forms you can use to request help from National Instruments or to comment on our products.
- The *Glossary* contains an alphabetical list and description of terms used in this manual, including abbreviations, acronyms, metric prefixes, and symbols.
- The *Index* alphabetically lists the topics in the manual, including the page where you can find each one.

Conventions Used in This Manual

The following conventions are used in this manual:

bold	Bold text denotes menus, menu items, or dialog box buttons or options.
<i>bold italic</i>	Bold italic text denotes a note, caution, or warning.
<i>italic</i>	Italic text denotes emphasis, a cross reference, or an introduction to a key concept.
monospace	Text in this font is used for function names.
SC-206X Series	SC-206X Series refers to SC-2060, SC-2061, or SC-2062 boards.
DIO board	DIO board refers to the NB-DIO-24, NB-DIO-32F, NB-DIO-96, MC-DIO-24, MC-DIO-32F, PC-DIO-24, ATDIO-32F, and PC-DIO-96 boards.
DIO-24	DIO-24 refers to the NB-DIO-24, MC-DIO-24, and PC-DIO-24 boards.
DIO-32F	DIO-32F refers to the NB-DIO-32F, MC-DIO-32F, and ATDIO-32F boards.
Lab/1200 Series	Lab/1200 Series refers to the Lab-LC, Lab-NB, Lab-PC, and Lab-PC+ boards, and the DAQCard-1200, DAQPad-1200, and PCI-1200 devices.
MIO-16	MIO-16 refers to the NB-MIO-16, NB-MIO-16X, MC-MIO-16, AT-MIO-16, AT-MIO-16D, AT-MIO-16F5, and AT-MIO-16X boards.
NI-DAQ	NI-DAQ refers to the NI-DAQ software for PC compatibles or Macintosh unless otherwise stated.
TIO-10	TIO-10 refers to the PC-TIO-10 board.

Abbreviations, acronyms, metric prefixes, and symbols are listed in the *Glossary*.

Related Documentation

The following National Instruments documents contain information that you may find helpful as you read this manual:

- Your DAQ hardware manuals
- *BNC-208X Series User Manual*
- *SC-205X User Manual*

- *SC-206X User Manual*
- National Instruments Application Note 043, *Measuring Temperature with Thermocouples*.
- NIST Monograph 175, *Temperature-Electromotive Force Reference Functions and Tables for the Letter-Designated Thermocouple Types Based on the ITS-90* (National Institute of Standards and Technology, Gaithersburg, MD 20899).

Customer Communication

National Instruments wants to receive your comments on our products and manuals. We are interested in the applications you develop with our products, and we want to help if you have problems with them. To make it easy for you to contact us, this manual contains comment and configuration forms for you to complete. These forms are in Appendix B, *Customer Communication*, at the end of this manual.

Chapter 1

Introduction

About the SC-207X Series Boards

This chapter describes the SC-207X Series boards, lists what you need to get started, describes the optional equipment and software, and explains how to unpack your SC-207X Series board.

The SC-2070 and SC-2071 boards are two general-purpose breadboards with signal-labeled screw terminals and temperature sensor, breadboard, and analog signal conditioning areas. The SC-2070 and SC-2071 boards can be used for analog signal conditioning on the Macintosh, IBM PS/2 Micro Channel, and IBM PC/XT/AT computers. The SC-2070 and SC-2071 breadboards simplify the connection of analog and digital signals to the DAQ board in laboratory, test, and production environments. Up to seven thermocouples can be connected to each SC-2070 or SC-2071 board while using one channel to monitor the onboard temperature sensor for cold-junction compensation. The temperature sensor can be disconnected to make all eight differential or 16 single-ended analog input channels available on the board. The boards have silkscreened component locations for resistors and capacitors for building single-pole highpass and lowpass filters, voltage dividers, and broken thermocouple detectors. The SC-2070 and SC-2071 boards also have a general-purpose breadboard area for building custom analog, digital, and timing circuits.

The SC-2072 board is a general-purpose breadboard with screw terminals and a breadboard area that can be used for building custom analog, digital, and timing circuits. The SC-2072 can be used with all National Instruments NB Series, MC Series, PC Series, AT Series, Lab/1200 Series, and the PC-OPDIO-16 DAQ, digital I/O, and timing boards (except the NB-A2000 and the EISA-A2000), and some DAQCards. The board comes with an optional DC-to-DC converter that converts the +5 V input into +15 V and -15 V for use by analog circuitry.

Detailed specifications of the SC-207X boards are in Appendix A, *Specifications*.

Table 1-1 lists the specific DAQ devices that can currently be used with the SC-207X Series boards.

Table 1-1. DAQ Devices for Use with SC-207X Series Boards

	NB Series (Macintosh)	MC Series (IBM PS/2)	PC and AT Series (PC/XT/AT)	Lab/1200 Series (PC/XT/AT and Macintosh)	Other Devices
SC-2070	NB-MIO-16, NB-MIO-16X	MC-MIO-16	AT-MIO-16, AT-MIO-16D ¹ , AT-MIO-16F-5, AT-MIO-16X, AT-MIO-64F-5 ¹		
SC-2071				Lab-LC ² , Lab-NB, Lab-PC+, DAQCard-1200 ³ , DAQPad-1200, PCI-1200	
SC-2072	NB-DIO-24, NB-DIO-32F, NB-MIO-16, NB-MIO-16X	MC-DIO-24, MC-DIO-32F, MC-MIO-16	AT-DIO-32F, AT-MIO-16, AT-MIO-16D ¹ , AT-MIO-16F-5, AT-MIO-16X, PC-DIO-24, PC-DIO-96, PC-LPM-16, PC-TIO-10	Lab-LC ² , Lab-NB, Lab-PC+, DAQCard-1200, DAQPad-1200, PCI-1200	DAQCard-700, DAQCard-DIO-24, PC-OPDIO-16
¹ Requires an NB5 cable, available separately. ³ Requires a PR50-50F cable, available separately. ² Requires an NB10 cable, available separately.					

All the signals from the DAQ board, both analog and digital, are made available at screw terminals. Each of the SC-207X Series boards is connected directly to the DAQ board by a 50-pin ribbon cable. If any SC-206X Series digital signal conditioning boards are also being used with the same DAQ board for conditioning of the digital I/O signals, then an SC-205X Series cable adapter board is required. Figure 1-1 shows the SC-2070 board, mounted in a 19-in. rack mount, directly connected to the MIO-16 board.

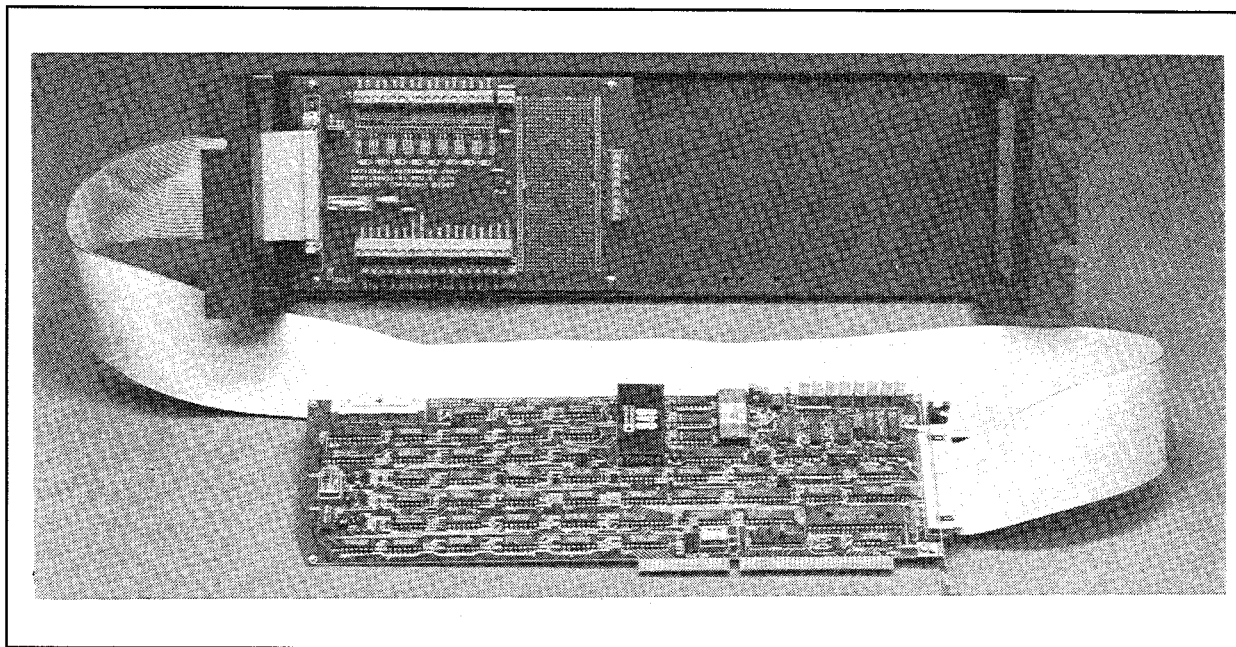

Figure 1-1. SC-2070 Board Connected Directly to an MIO-16 Board

The SC-207X Series boards can be mounted beside an SC-205X Series cable adapter board or an SC-206X Series signal conditioning board in a 19-in. rack-mount chassis. You can mount your SC-207X Series board on the left or right side of the rack mount. Figure 1-2 shows the SC-207X, SC-206X, and SC-205X Series boards connected to an MIO-16 board.

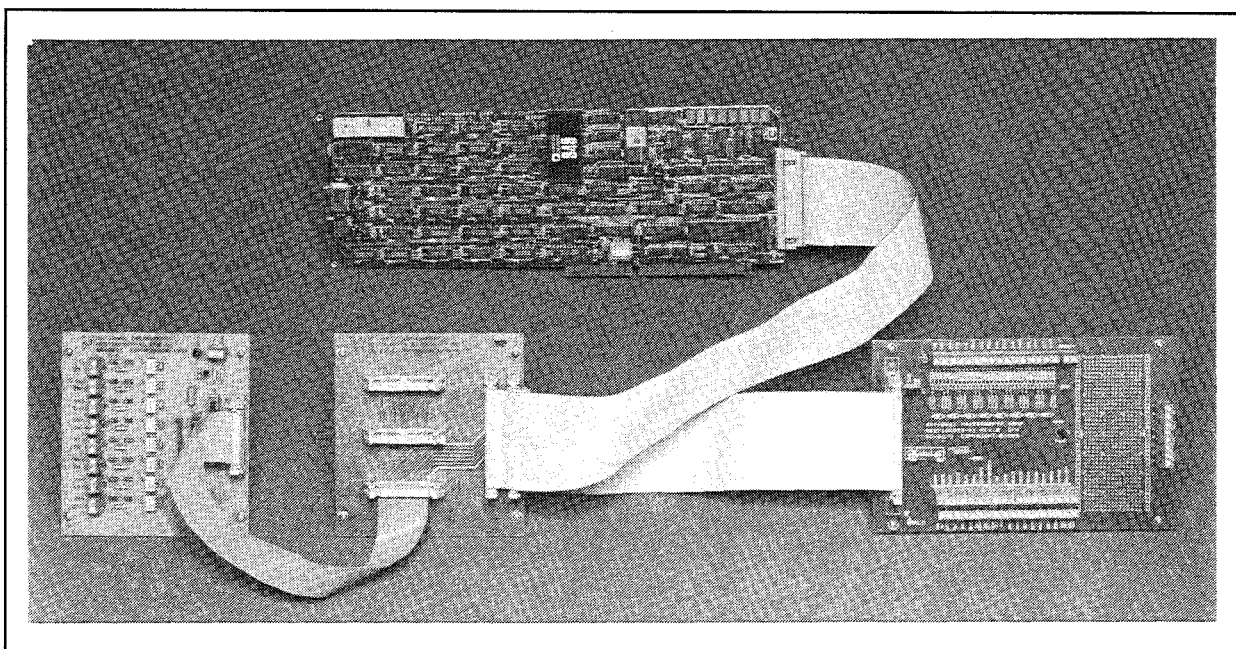

Figure 1-2. SC-207X Series Board, SC-206X Series Board, and SC-205X Series Board Connected to an MIO-16 Board

What You Need to Get Started

To set up and use your SC-207X board, you will need the following:

- ❑ SC-2070, SC-2071, SC-2072, or SC-2072D board
- ❑ *SC-207X Series User Manual*
- ❑ 50-conductor NB1 0.5 or 1.0 m cable (some kits do not contain either cable)
- ❑ Your computer

Optional Equipment

You can use the following National Instruments products with your SC-207X Series board:

- Type NB5 ribbon cable, 0.5 or 1.0 m
- Type NB10 cable
- Rack-mount chassis kit with acrylic plastic cover, single or double height
- Rack-mount chassis kit with metal wraparound cover, single or double height
- SSR Series eight-channel backplane with 0.4 m cable for SC-2050 Series
- SC-2060 and 26-conductor cable, 0.2 or 0.4 m
- SC-2061 and 26-conductor cable, 0.2 or 0.4 m
- SC-2062 and 26-conductor cable, 0.2 or 0.4 m
- SC-2050 and 50-conductor cable, 0.5 or 1.0 m
- SC-2051 and 50-conductor cable, 0.5 or 1.0 m
- SC-2052 and 50-conductor cable, 0.5 or 1.0 m
- SC-2053 and 50-conductor cable, 0.5 or 1.0 m
- PR50-50F cable

Software

The SC-207X Series boards require no additional software support beyond what you are using for your DAQ device.

Unpacking

Your SC-207X board is shipped in an antistatic package to prevent electrostatic damage to the board. Electrostatic discharge can damage several components on the board. To avoid such damage in handling the board, take the following precautions:

- Ground yourself via a grounding strap or by holding a grounded object.
- Touch the antistatic package to a metal part of your computer chassis before removing the board from the package.
- Remove the board from the package and inspect the board for loose components or any other sign of damage. Notify National Instruments if the board appears damaged in any way. *Do not* install a damaged board into your computer.
- *Never* touch the exposed pins of connectors.

Chapter 2

SC-2070 Board

This chapter describes the SC-2070 board in detail, including function, compatibility, connection, mounting, and applications. This chapter also discusses working with thermocouples.

The SC-2070 is a general-purpose termination breadboard that makes it easy to connect to all MIO-16 board I/O signals; add analog input signal conditioning, such as filters, dividers, and thermocouple compensation; and build external, custom timing, analog, and digital circuits.

The SC-2070 board is used with National Instruments DAQ boards for the Macintosh (NB Series), IBM PS/2 Micro Channel (MC Series), and PC/XT/AT and compatible (AT Series) computers.

The SC-2070 board has screw terminals for all DAQ board signals. With these terminals, the board easily connects to the analog, digital, timing, and trigger signals. The SC-2070 has an onboard temperature sensor that can be optionally jumpered to differential channel 0 for thermocouple cold-junction compensation. With open component positions in the input paths, you can insert resistors and capacitors for conditioning the 16 single-ended or 8 differential analog input signals. A 1.5 by 4 in. general-purpose breadboard area is also included. The SC-207X Series boards can also be used in conjunction with the other signal conditioning accessories, including the SC-206X Series boards and SSR Series boards. To connect multiple signal conditioning accessories, you must use an SC-205X Series cable adapter board.

Figure 2-1 shows the parts locator diagram for the SC-2070 board.

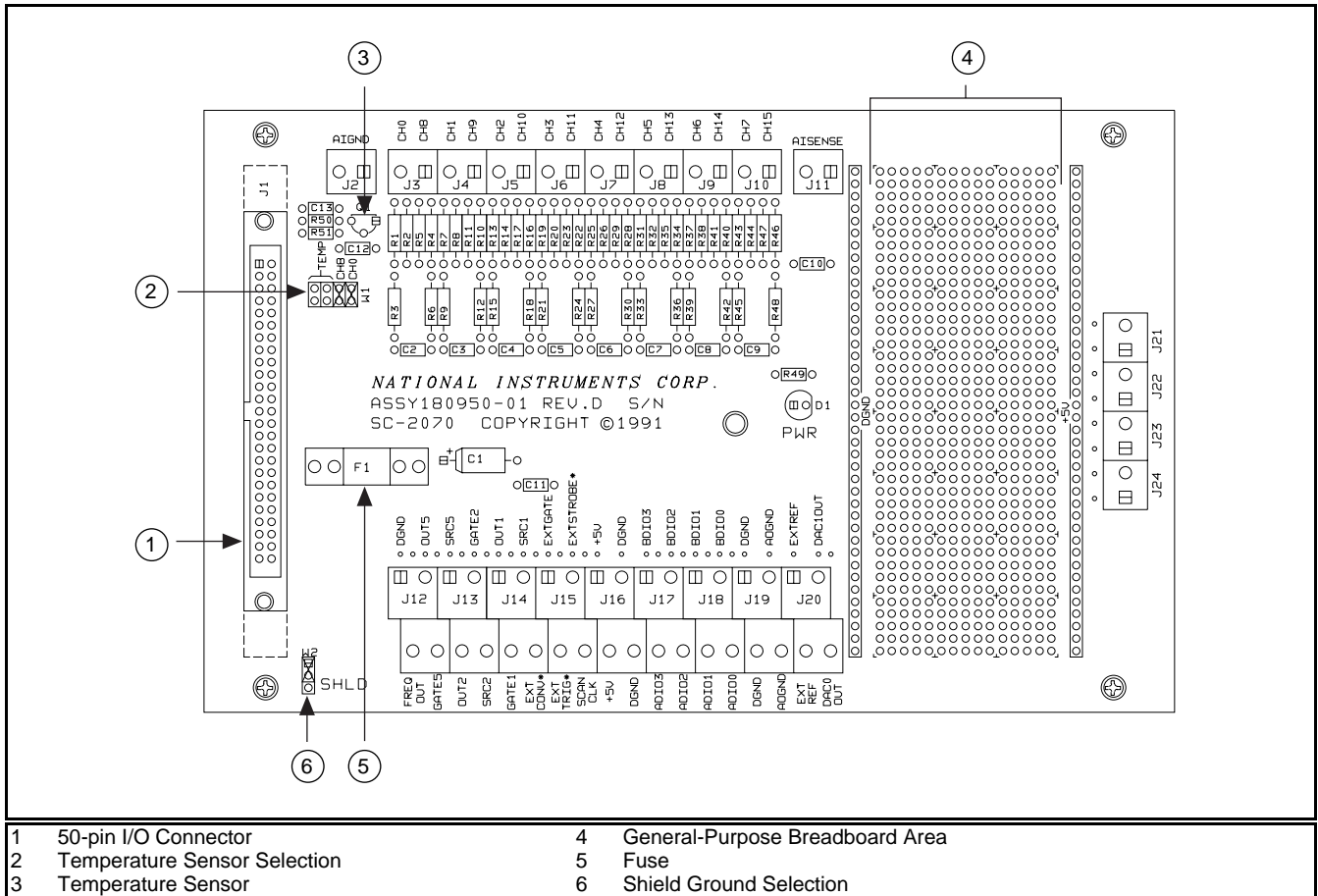

Figure 2-1. SC-2070 Board Parts Locator Diagram

Analog Input

Each differential analog input has seven open positions for signal conditioning components. Six of these positions are designated as resistors, and one is designated as a capacitor. The board is shipped with jumpers in two positions for each input. The equivalent circuit of one input is shown in Figure 2-2. The board can be used when the MIO-16 board is configured for both 16 single-ended inputs and eight differential inputs. For thermocouple and other low-level applications, best results are obtained when differential inputs are used. For specific applications illustrating signal conditioning with both single-ended and differential inputs, refer to *Applications* later in this chapter.

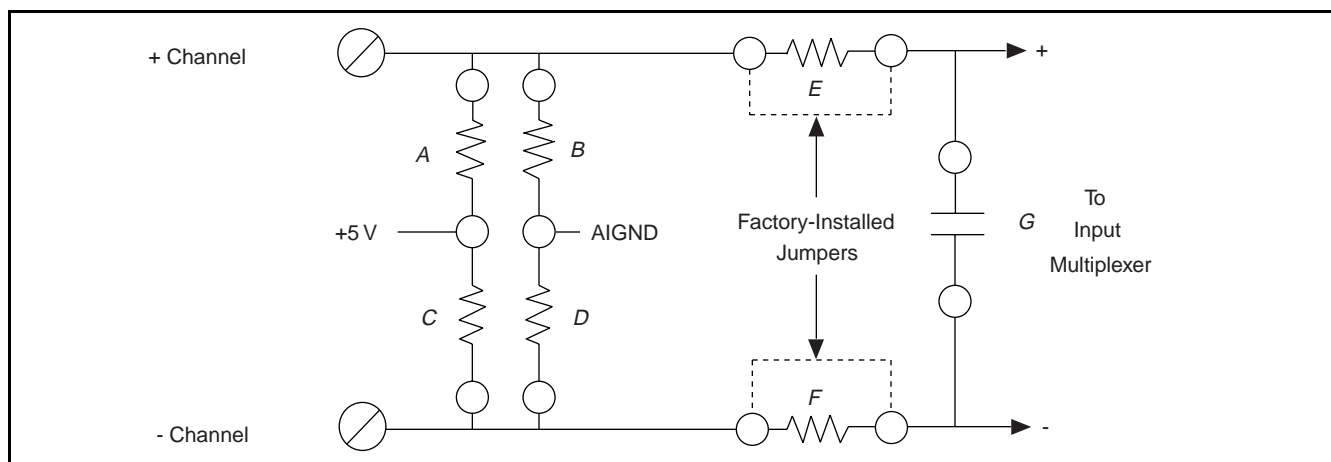

Figure 2-2. Onboard Equivalent Circuit

The components are numbered differently for each channel. Table 2-1 lists the components in each channel and their correspondence to the circuit shown in Figure 2-2.

Table 2-1. Component Positions in Each Channel

Channel		(Position in Figure 2-2)						
Differential	Single-Channel	A	B	C	D	E	F	G
0	(0,8)	R2	R1	R5	R4	R3	R6	C2
1	(1,9)	R8	R7	R11	R10	R9	R12	C3
2	(2,10)	R14	R13	R17	R16	R15	R18	C4
3	(3,11)	R20	R19	R23	R22	R21	R24	C5
4	(4,12)	R26	R25	R29	R28	R27	R30	C6
5	(5,13)	R32	R31	R35	R34	R33	R36	C7
6	(6,14)	R38	R37	R41	R40	R39	R42	C8
7	(7,15)	R44	R43	R47	R46	R45	R48	C9

When the board is shipped, jumpers are inserted in the *E* and *F* positions of the input network (see Figure 2-2). These jumpers can be easily removed to build analog input signal conditioning circuits. Several applications showing the use of these open component positions are discussed in *Applications* later in this chapter.

Temperature Sensor

The SC-2070 board is equipped with an onboard temperature sensor for use with thermocouple cold-junction compensation. This sensor, a National Semiconductor LM-35CZ, generates a voltage output of 10 mV/°C, with an accuracy of ±1° C. The sensor is jumper-selected on differential input channel 0. The MIO-16 board can be configured for either differential or single-ended inputs if this temperature sensor is used. Jumper W1 is used to select either the temperature sensor or the external screw terminals as the input source for differential channel 0. If the temperature sensor is chosen, any signal conditioning that has been installed on channel 0 is ignored and has no effect. Figure 2-3 shows the positions for jumper W1.

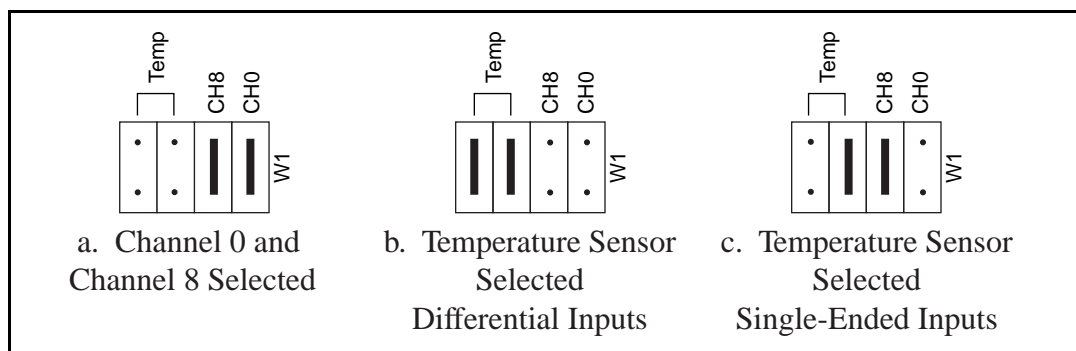

Figure 2-3. W1 Jumper Settings

Shield Ground

Jumper W2 is used to connect digital ground (DGND) to a grounded metal case. This option is useful only if the SC-2070 board is on metal standoffs and is mounted in a grounded metal case. Select shield grounding to reduce noise. Figure 2-4 details the jumper settings for W2.

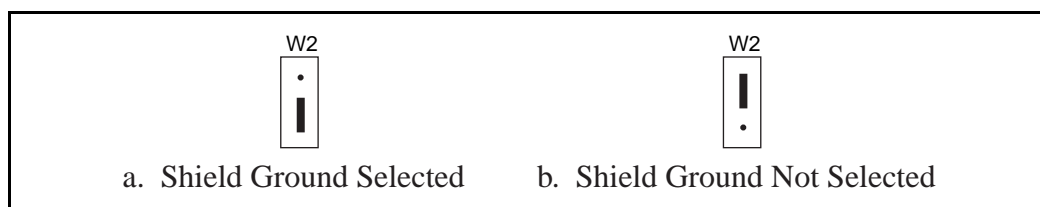

Figure 2-4. W2 Jumper Settings

Fuse and Power LED

The +5 V line from the DAQ board is protected by an 800 mA fuse. If the red power LED does not light when the DAQ board is powered on, check both the 800 mA fuse on the SC-2070 board and the output fuse (if any) on the MIO-16 board. See Chapter 5, *Installation and Connections*, for information on connecting power.

Digital and Timing Signals

All of the signals from the MIO-16 board are made available at screw terminals on the SC-2070 board. Because these signals are not conditioned or changed in any way by the SC-2070 board, refer to your MIO-16 board user manual for information on using these signals. If you want optical isolation of or relay control by the digital I/O lines, then you must use the SC-2050 cable adapter board and the appropriate SC-2060 digital signal conditioning board. For more information on the SC-205X Series boards or the SC-206X Series boards, refer either to your National Instruments catalog, the *SC-205X Series User Manual*, or the *SC-206X Series User Manual*.

Board-to-Board Cabling

The SC-2070 board connects directly to any of the DAQ boards listed in Table 2-2.

Table 2-2. DAQ Boards Used with the SC-2070 Board

	NB Series (Macintosh)	MC Series (IBM PS/2)	AT Series (PC AT)
SC-2070	NB-MIO-16 NB-MIO-16X	MC-MIO-16	AT-MIO-16 AT-MIO-16D* AT-MIO-16F-5 AT-MIO-16X AT-MIO-64F-5*
* Requires an NB5 cable, available separately.			

The DAQ boards listed in Table 2-2 connect to the SC-2070 board as shown in Figure 2-5. If you are using the SC-2070 board with the AT-MIO-16D or AT-MIO-64F-5 board, the 50-conductor cable is replaced with a type NB5 100-conductor ribbon cable. The NB5 cable terminates with two 50-pin connectors, one of which may be connected to the SC-2070 board.

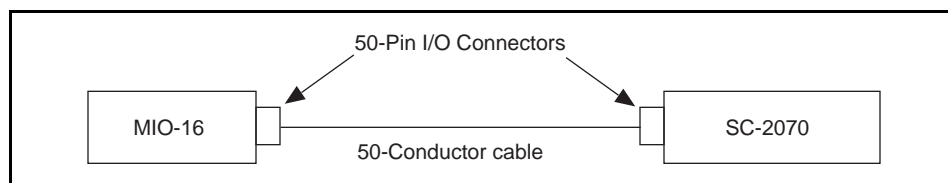

Figure 2-5. Direct Connection between an MIO-16 Board and the SC-2070 Board

If any signal conditioning of the digital I/O ports with the National Instruments SC-206X Series boards is desired, then the SC-2050 cable adapter board must be used with the DAQ boards listed in Table 2-2. Figure 2-6 shows a connection using the SC-2050 cable adapter board.

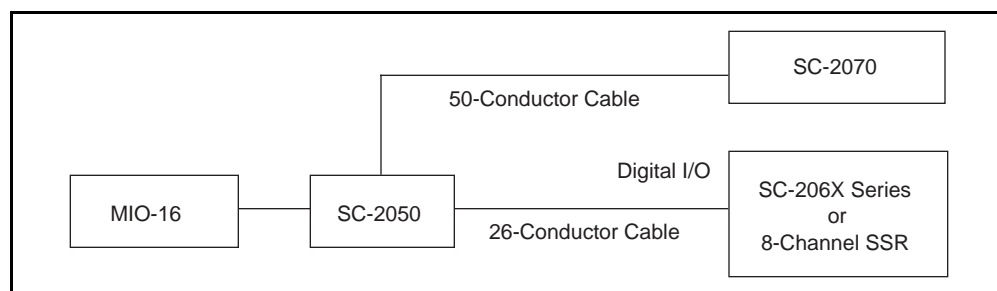

Figure 2-6. Connection between an MIO-16 Board and the SC-2070 Board via the SC-2050 Board

Warning: *Do not connect the SC-2070 board to any board other than a National Instruments MIO-16 board or the SC-2050 cable adapter board. The SC-2070 board is not compatible with any other DAQ boards or cable adapter boards. Attempts to use the SC-2070 board with products for which it is not intended can result in damage to the SC-2070 board, the DAQ board, or the host computer. National Instruments is NOT liable for damages resulting from these connections.*

The SC-2070 board uses a 50-pin ribbon cable connector to connect to the 50-pin I/O connector on either a DAQ board or the SC-2050 cable adapter board. If you are using the SC-2050 cable adapter board, the SC-2050 connects to the DAQ board with a 50-conductor ribbon cable. The SC-2070 board then connects to the other 50-pin I/O connector on the SC-2050 board. For more information, see Chapter 5, *Installation and Connections*.

Mounting

The SC-2070 board is equipped with metal standoffs so the board can be placed on a workbench near the host computer. You can use an optional rack-mount chassis, which can be fitted with a flat, acrylic plastic cover. When the SC-2070 board is mounted in the chassis, the board can be grounded to its metal standoffs, and therefore to the rack. For more information, see Chapter 5, *Installation and Connections*.

Applications

The open component positions on the SC-2070 board make adding signal conditioning components to the analog input signals easier. Several applications are covered in this section, including thermocouple readings, filtering, and attenuation.

The figures in this section give examples on a specific input channel. To install the circuit on a different channel, see Table 2-1 to determine the equivalent component positions for the other channels.

Soldering and Desoldering on the SC-2070 Board

The applications discussed here require modifications to the printed circuit board, usually in the form of removing jumpers and adding components. The SC-2070 board is shipped with wire jumpers in the *E* and *F* positions (see Table 2-1 and Figure 2-2). Use a low-wattage soldering iron (20 to 30 W) when soldering to the board. To desolder on the SC-2070, vacuum-type tools work best. Use care when desoldering to avoid damaging component pads. Only use rosin-core electronic grade solder. Acid-core solder damages the printed circuit board and components.

Channel Configurations

You can configure the analog input channels of an MIO-16 board for one of three input modes: differential (DIFF) input, referenced single-ended input (RSE), or nonreferenced single-ended (NRSE) input.

As described in Chapter 2 of the MIO-16 user manual, the input configuration of the MIO-16 depends on the type of signal source. There are two types of signal sources: nonreferenced or floating signals and ground-referenced signals. To measure floating signal sources, configure the MIO-16 for referenced single-ended input or differential input with bias resistors. To measure ground-referenced signal sources, configure the MIO-16 for nonreferenced single-ended input or differential input. Both types of signal sources and the recommended methods for MIO-16 board connection are discussed as follows.

Connecting Nonreferenced or Floating Signal Sources

A floating signal source is a signal source that is not connected in any way to the building ground system, but has an isolated ground-reference point. If an instrument or device has an isolated output, that instrument or device falls into the floating signal source category. Some examples of floating signal sources are outputs for: thermocouples, transformers, battery-powered devices, optical isolators, and isolation amplifiers. The ground reference of a floating source must be tied to the ground of the DAQ board to establish a local or onboard reference for the signal.

Differential Inputs

To provide a return path for the instrumentation amplifier bias currents, floating sources must have a 10 to 100 k Ω resistor to AIGND on one input if DC-coupled, or both inputs if AC-coupled. For more detailed information on connections to floating signal sources and differential inputs, refer to the configuration chapter in your MIO-16 board user manual. These bias resistors can be installed in positions B and D (Table 2-1 and Figure 2-2) of the SC-2070 board. Figure 2-7 shows both the schematic and the component placement for a single 100-k Ω bias return resistor on the negative input from a floating source connected to channel 1 (the D position in Table 2-1). Additional signal conditioning circuitry, such as filters and attenuators (described in *Building Lowpass Filters*, *Building Highpass Filters*, and *Building Attenuators* later in this chapter), can be built in the open component positions.

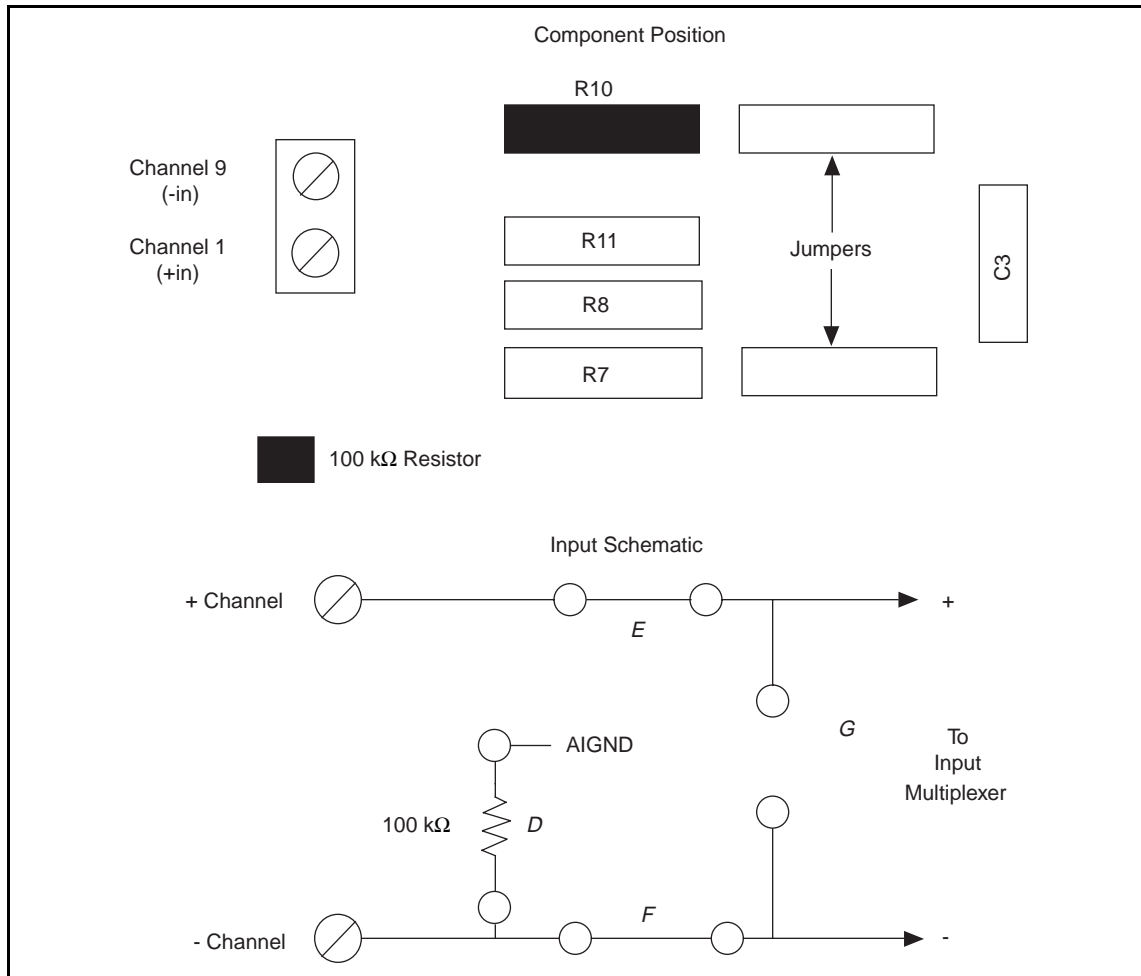

Figure 2-7. Bias Return Resistor for DC-Coupled Floating Source on Channel 1

Single-Ended Inputs

When measuring floating signal sources, configure the MIO-16 board to supply a ground reference. Therefore, configure the MIO-16 for referenced single-ended input. In this configuration, the negative input of the MIO-16 instrumentation amplifier is tied to the analog ground. Therefore, use the SC-2070 board in its factory configuration. In the factory configuration, jumpers are in the two series positions, *E* and *F* (see Table 2-1). In this configuration, all of the signal grounds should be tied to AIGND. Signal conditioning circuitry such as filters and attenuators (described in *Building Lowpass Filters*, *Building Highpass Filters*, and *Building Attenuators* later in this chapter) can be built in the open component positions.

Connecting Ground-Referenced Signal Sources

A grounded signal source is connected in some way to the building system ground; therefore, the signal source is already connected to a common ground point with respect to the DAQ board (assuming the host computer is plugged into the same power system). Nonisolated outputs of instruments and devices that plug into the building power system fall into this category.

Differential Inputs

If the MIO-16 board is configured for differential inputs, ground-referenced signal sources connected to the SC-2070 board need no special components added to the SC-2070 board. The SC-2070 board inputs can be left in the factory-original condition, only with jumpers in the two series positions, *E* and *F* (see Table 2-1). Signal conditioning circuitry, such as filters and attenuators (described in *Building Lowpass Filters*, *Building Highpass Filters*, and *Building Attenuators* later in this chapter), can be built in the open component positions.

Single-Ended Inputs

When measuring ground-referenced signals, the external signal supplies its own reference ground point and the MIO-16 should not supply one. Therefore, configure the MIO-16 board for nonreferenced single-ended input mode. In this configuration, all of the signal grounds should be tied to AISENSE, which connects to the negative input of the instrumentation amplifier on the MIO-16 board. The SC-2070 board inputs can be left in the factory-original condition, with jumpers in the series position (*E* or *F*, depending on the channel). Do not use the open positions that connect the input to AIGND, *B* and *D* (see Table 2-1 and Figure 2-2) in this configuration. Therefore, signal conditioning circuitry requiring a ground reference should not be built in the open component positions, but must be built in the custom breadboard area using AISENSE as the ground reference. Referencing the signal to AIGND can cause inaccurate measurements resulting from an incorrect ground reference.

Building Lowpass Filters

Simple, RC lowpass filters are easily installed in the SC-2070 board on any differential input channel. The filters are useful for accurate measurement and noise rejection. By substituting resistance and capacitance values into the following Formula (hereafter referred to as Formula 2-1), you can calculate a simple, one-pole RC filter to have a -3 dB point (cutoff frequency):

$$f_c = \frac{1}{(2\pi RC)} \quad (\text{Formula 2-1})$$

The frequency response rolls off at a rate of -20 dB per decade of increase thereafter. A Bode plot of the amplitude versus normalized frequency is shown in Figure 2-8.

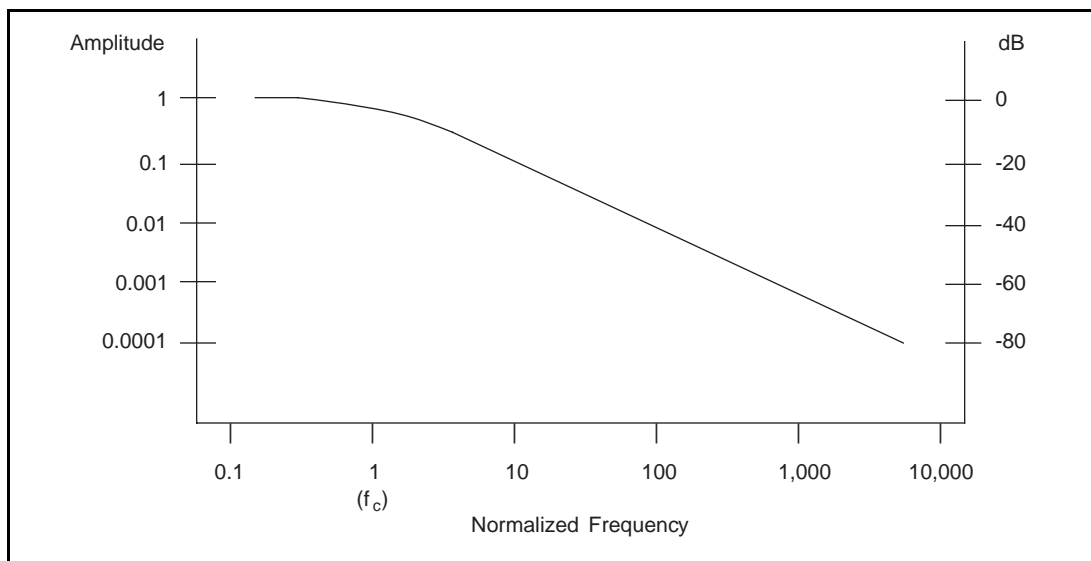

Figure 2-8. Normalized Frequency Response of Lowpass Filter

When measuring low-frequency signals (about 4 Hz), if you have 400-Hz noise on your inputs, you can add a lowpass filter with a cutoff frequency of 4 Hz. The 400-Hz noise then attenuates by 40 dB. Notice that your 4-Hz signal also attenuates, but by only 3 dB. Do not neglect any potential attenuation of signals of interest by this low-order filter.

You must also choose the filter component values. The resistance or the capacitance can be selected arbitrarily; one value determines the other. Picking the capacitor first and letting its value determine the resistance required is preferable because more standard resistor values are available. If a capacitance of 1 μF is available, the resistance is (by substitution into Formula 2-1) 39,789 Ω , or about 39.8 k Ω . Divide this resistance by two to get the resistor value on each input of a differential channel. Therefore, in this example, each input has a 19.89-k Ω resistor (or closest standard value) in its series positions, *E* and *F*. The closest standard 5% tolerance resistors are 20 k Ω . The closest standard 0.5% resistors are 19.8 k Ω . National Instruments recommends using 1% or better tolerance resistors in this application because differences between the resistor values degrade the common-mode rejection ratio. Figure 2-9 shows both the schematic and the component placement for a 4-Hz lowpass filter placed on differential input channel 1. If the input signal source is floating, place a bias return resistor in the *D* position (*R10* in this case).

The SC-2070 board open-component locations do not facilitate RC lowpass filters with the MIO-16 board configured for single-ended inputs. Therefore, if the MIO-16 board is configured for single-ended inputs, lowpass filters must be built on the custom breadboard area.

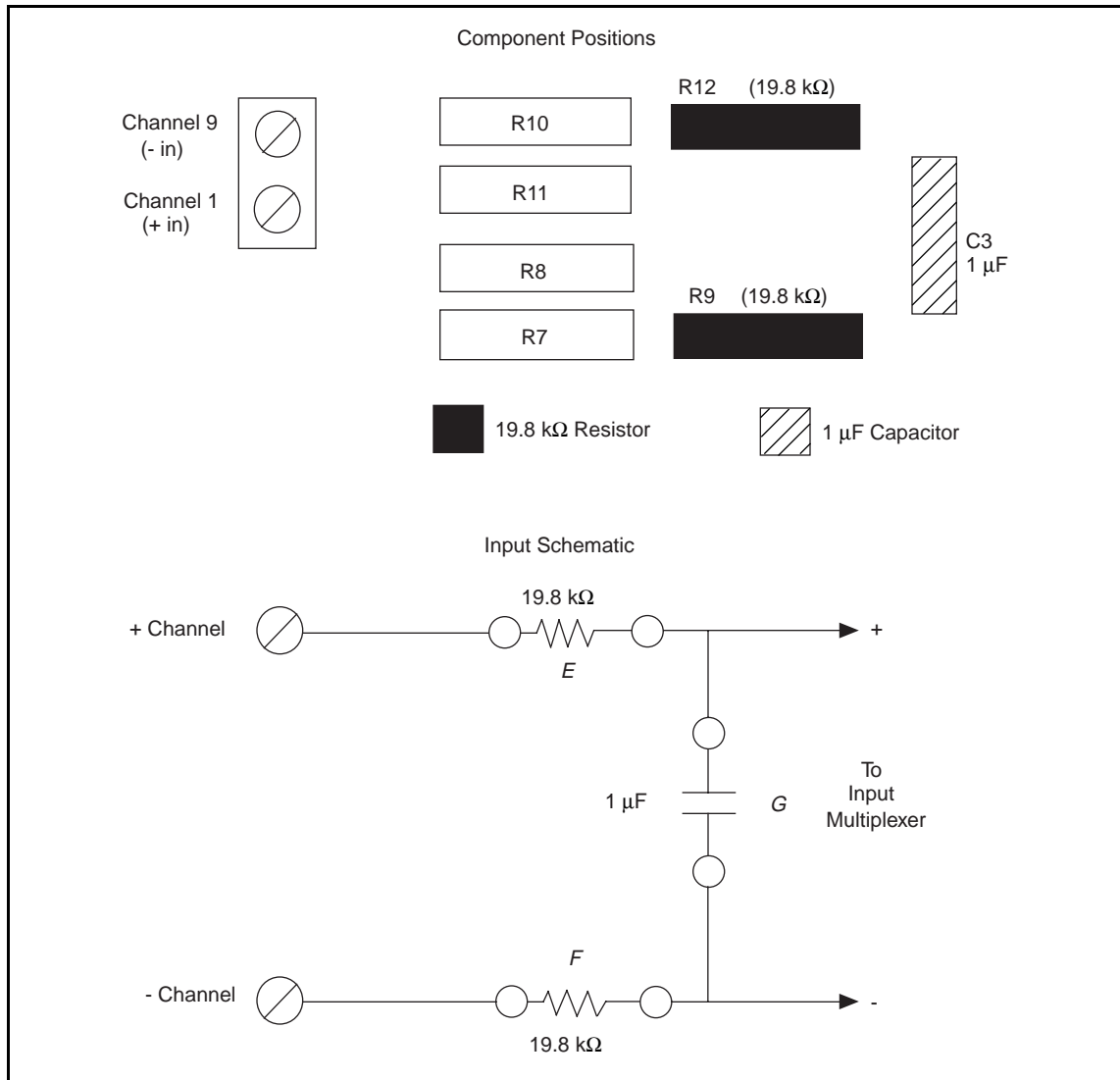

Figure 2-9. Lowpass Filter on Differential Channel 1

Building Highpass Filters

Simple, RC highpass filters are easily installed in the SC-2070 board on any differential input channel. The filters are useful for accurate high-frequency measurement and low-frequency noise rejection. By substituting resistance and capacitance values into the following formula, you can calculate a simple, one-pole RC filter to have a -3 dB point (cutoff frequency):

$$f_c = \frac{1}{(2\pi RC)} \quad (\text{Formula 2-2})$$

The frequency response rolls off at a rate of -20 dB per decade decrease thereafter. A Bode plot of the amplitude versus normalized frequency is shown in Figure 2-10.

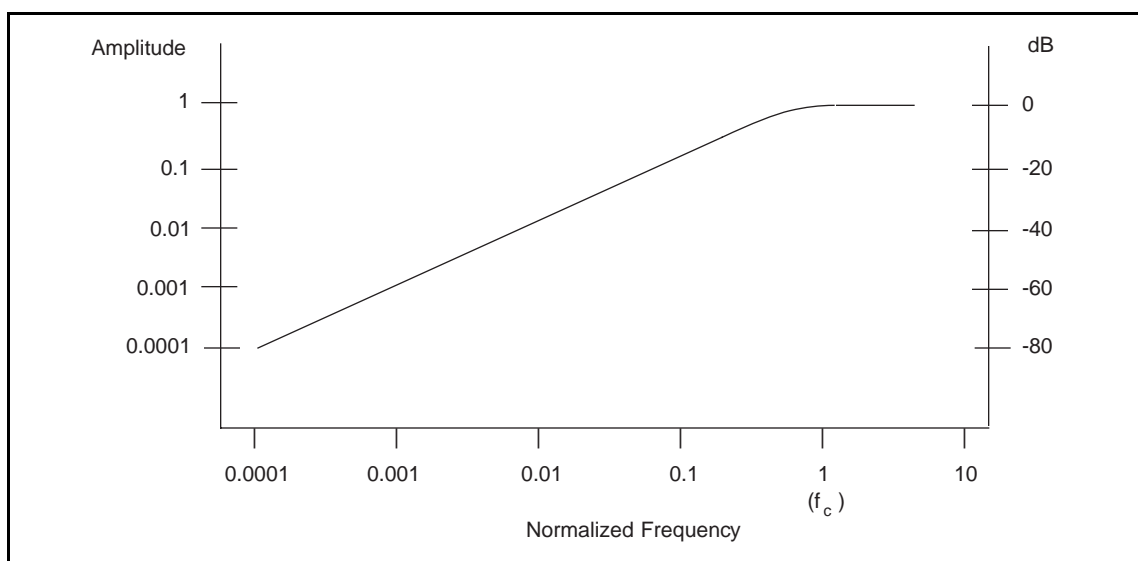

Figure 2-10. Normalized Frequency Response of Highpass Filter

When measuring high-frequency signals (about 50 kHz), if you have 50-Hz noise on your inputs, you can add a highpass filter with a cutoff frequency of 50 kHz. The 50-Hz noise then attenuates by 60 dB. Notice that your 50-kHz signal also attenuates, but by only 3 dB. Do not neglect any potential attenuation of signals of interest if you add a low-order filter.

You must also choose the filter component values. The resistance or the capacitance can be selected arbitrarily; one value determines the other. Picking the capacitor first and letting its value determine the resistance required is preferable because more standard resistor values are available. The filter circuit has one series capacitor on each input of the differential channel. Because the two capacitors are in series, the capacitance value that must be substituted into Formula 2-2 is the series capacitance of the two capacitors in series. For two capacitors in series, the net capacitance is the reciprocal of the sum of the reciprocals of the two capacitances. For example, two 0.001 μF capacitors in series have a net capacitance of 0.0005 μF . The two capacitors should be the same value, or the common mode rejection is degraded. If capacitors of 0.001 μF are available, the resistance is (by substitution into Formula 2-2) 6,366 Ω , or about 6.4 k Ω . Therefore, in this example, the input channel has a 6.37-k Ω resistor (or closest standard value) in its capacitor position, G . The closest standard 5% tolerance

resistors are 6.2 kΩ. The closest standard 1% resistors are 6.34 kΩ. Figure 2-11 shows both the schematic and the component placement for a 50-kHz highpass filter placed on differential input channel 1. If the input signal source is floating, a bias return resistor must be placed in the *D* position (*R10* in this case).

Note: *Highpass filters generally exhibit poorer common-mode rejection characteristics than lowpass filters because capacitors are in the series input paths. Capacitors have poorer tolerances than resistors, and matching of the input impedances is crucial for good common-mode rejection.*

The SC-2070 board open component locations do not facilitate RC highpass filters with the MIO-16 board configured for single-ended inputs. Therefore, if the MIO-16 board is configured for single-ended inputs, highpass filters must be built on the custom breadboard area.

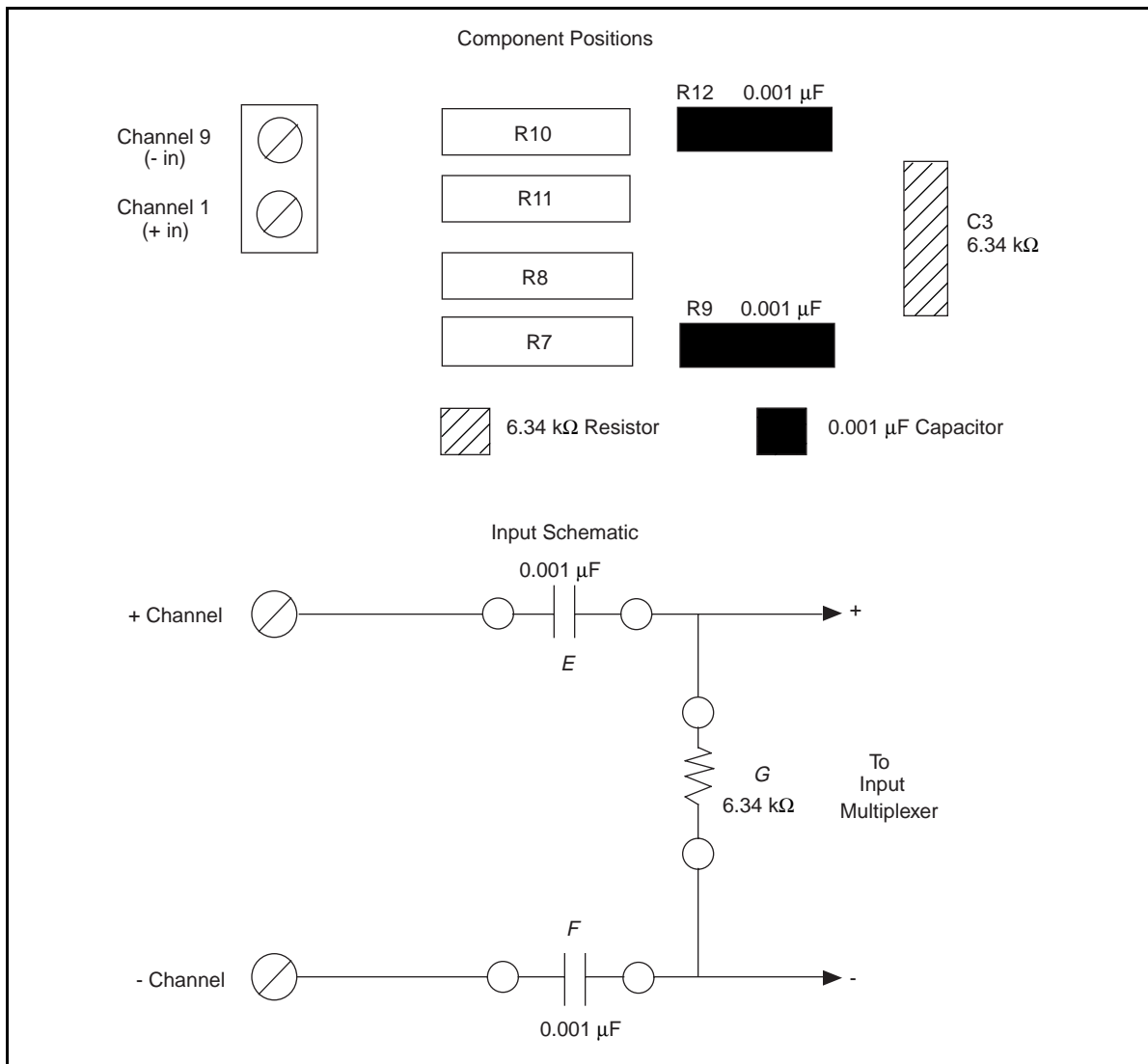

Figure 2-11. Highpass Filter on Differential Channel 1

Building Attenuators (Voltage Dividers)

Attenuators (voltage dividers) can be connected to the analog inputs of the SC-2070 board when the inputs from its DAQ board are in differential mode. The SC-2070 board open component positions do not facilitate voltage dividers with the MIO-16 board configured for single-ended inputs. Therefore, if the MIO-16 board is configured for single-ended inputs, attenuators must be built on the custom breadboard area. Attenuators can be used to reduce a signal that is outside the normal input range of the DAQ board (± 10 V maximum).

Warning: *The SC-2070 board is not designed for any input voltages greater than 42 V, even if a user-installed voltage divider reduces the voltage to within the input range of the DAQ board. Input voltages greater than 42 V can result in damage to the SC-2070 board, any and all boards connected to it, and the host computer. Overvoltage can also cause an electric shock hazard for the operator. National Instruments is NOT liable for damage or injury resulting from such misuse.*

A three-resistor circuit for attenuating voltages at the differential inputs of the SC-2070 board is shown in Figure 2-12. The figure also shows the placement of the resistors on the open component positions for differential channel 1. The gain G of this attenuator is given by the following formula:

$$G = \frac{R_G}{(R_E + R_F + R_G)} \quad (\text{Formula 2-3})$$

Therefore, the input to the MIO-16 board (V_{MIO}) is

$$V_{\text{MIO}} = V_{\text{SC}} * G$$

where V_{SC} is the voltage applied to the screw terminals of the SC-2070. The accuracy of this gain equation depends on the tolerances of the resistors used.

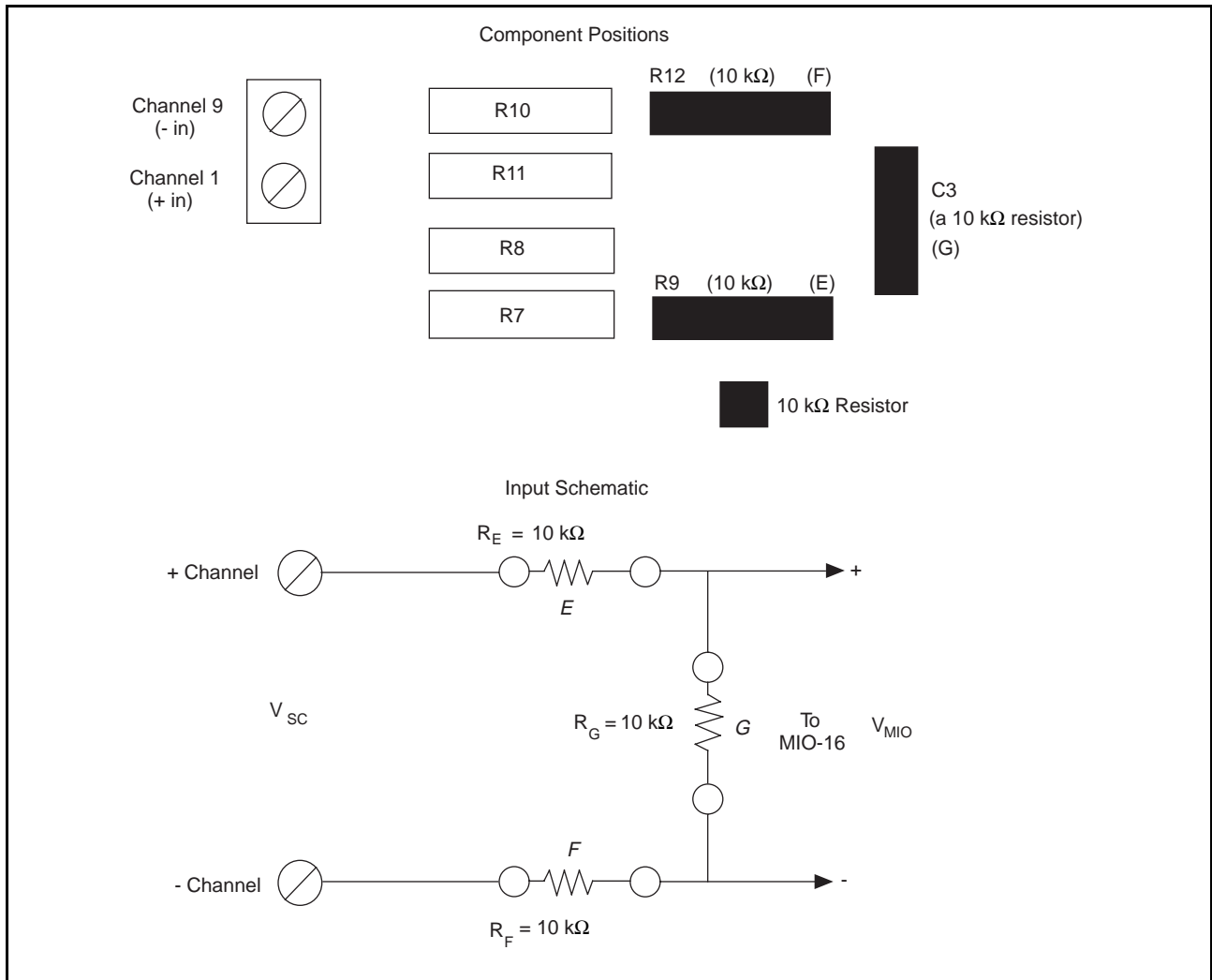

Figure 2-12. Attenuator for Use with Differential Inputs

Example:

Using the values in Figure 2-12,

$$G = \frac{10 \text{ k}\Omega}{(10 \text{ k}\Omega + 10 \text{ k}\Omega + 10 \text{ k}\Omega)} = \frac{1}{3}$$

Therefore,

$$V_{\text{MIO}} = \frac{1}{3} V_{\text{SC}}$$

When the MIO-16 is configured for $\pm 10 \text{ V}$ inputs, the board can acquire $\pm 30 \text{ V}$ signals with this attenuator circuit.

Working with Thermocouples

One of the most frequently used temperature transducers is the thermocouple. A thermocouple is created when two dissimilar metals are brought in contact, and the contact produces a small voltage as a function of temperature. In most measurement situations, a thermocouple is placed where the temperature is to be measured; then two wires, consisting of the same type of metal as each side of the thermocouple, are run back to a termination panel such as the SC-2070. Additional dissimilar junctions are formed where these wires contact the screw terminals, and each of these junctions generates its own temperature-dependent voltage. Other temperature-dependent voltages are generated at ribbon cable junctions and solder joints. However, effects of these junctions are negligible and tend to cancel in most cases. The voltage measured by the DAQ board is the sum of the voltages of *all* dissimilar metal junctions in the circuit, not just the thermocouple junction used to measure temperature.

You only need to know the temperature of the screw terminal junctions to compensate for all dissimilar metal junctions in a system with constant temperature (Thermocouple Law of Intermediate Metals). Therefore, if you know the temperature at the screw terminals, you can easily calculate the temperature at the point of interest from the voltage measured. A National Semiconductor LM-35CZ is used on the SC-2070 board to determine the temperature of the screw terminals. The dissimilar metal junctions at the screw terminals are also referred to as the *cold junction*. The process of using the known temperature at that point to find the temperature at the unknown point is called *cold-junction compensation* (CJC).

Thermocouples are usually more desirable than direct-reading sensors for several reasons. Thermocouples are more rugged than most other sensors and can tolerate several hundred degree temperatures without degradation. Semiconductor sensors, the easiest to use, usually cannot be used above 70° C. Thermocouples are inexpensive and physically small, so they can track temperature changes rapidly.

Thermocouple output voltages are very low, on the order of 50 $\mu\text{V}/^\circ\text{C}$. The temperature coefficient changes with temperature, resulting in a nonlinear curve. The temperature can be determined from tables available from thermocouple vendors or calculated from polynomial equations such as those given in the next section.

Using the SC-2070 Board for Thermocouple Measurements

The maximum voltage level generated by thermocouples is typically a few millivolts. Therefore, an MIO-16 with high gain (MIO-16L) should be used for best resolution. Thermocouples can be measured in either differential or single-ended configurations. Differential configuration has better noise immunity, but single-ended configuration has twice as many inputs. The MIO-16 board must have a ground reference because thermocouples are floating signal sources. Therefore, use bias resistors if the board is in differential mode. For single-ended configuration, use the referenced single-ended input configuration.

Cold-junction compensation with the SC-2070 board is accurate only if the temperature sensor reading is close to the actual temperature of the screw terminals. Therefore, when thermocouples are being read, keep the SC-2070 board away from drafts or other temperature gradients such as those caused by heaters, radiators, fans, and very warm equipment.

Input Filtering and Broken Thermocouple Detection (Optional)

To reduce noise, a lowpass filter can be connected. Refer to *Building Lowpass Filters* earlier in this chapter for an explanation of how to design these filters.

Broken thermocouple detection circuitry is built by connecting a high-value resistor between the positive input and +5 V. The value of this resistor is relatively unimportant; a few megohms or more works fine. With a high-value resistor, you can detect an open or defective thermocouple. If the thermocouple opens, the voltage measured across the input terminals rises to +5 V, a value much larger than any legitimate thermocouple voltage. The 100-k Ω resistor between the negative input and AIGND is a bias current return path as described under *Connecting Floating Signal Sources* earlier in this chapter. A sample circuit and component placement for a lowpass filter and broken thermocouple detection are shown in Figure 2-13. Assume the thermocouple is connected to channel 1.

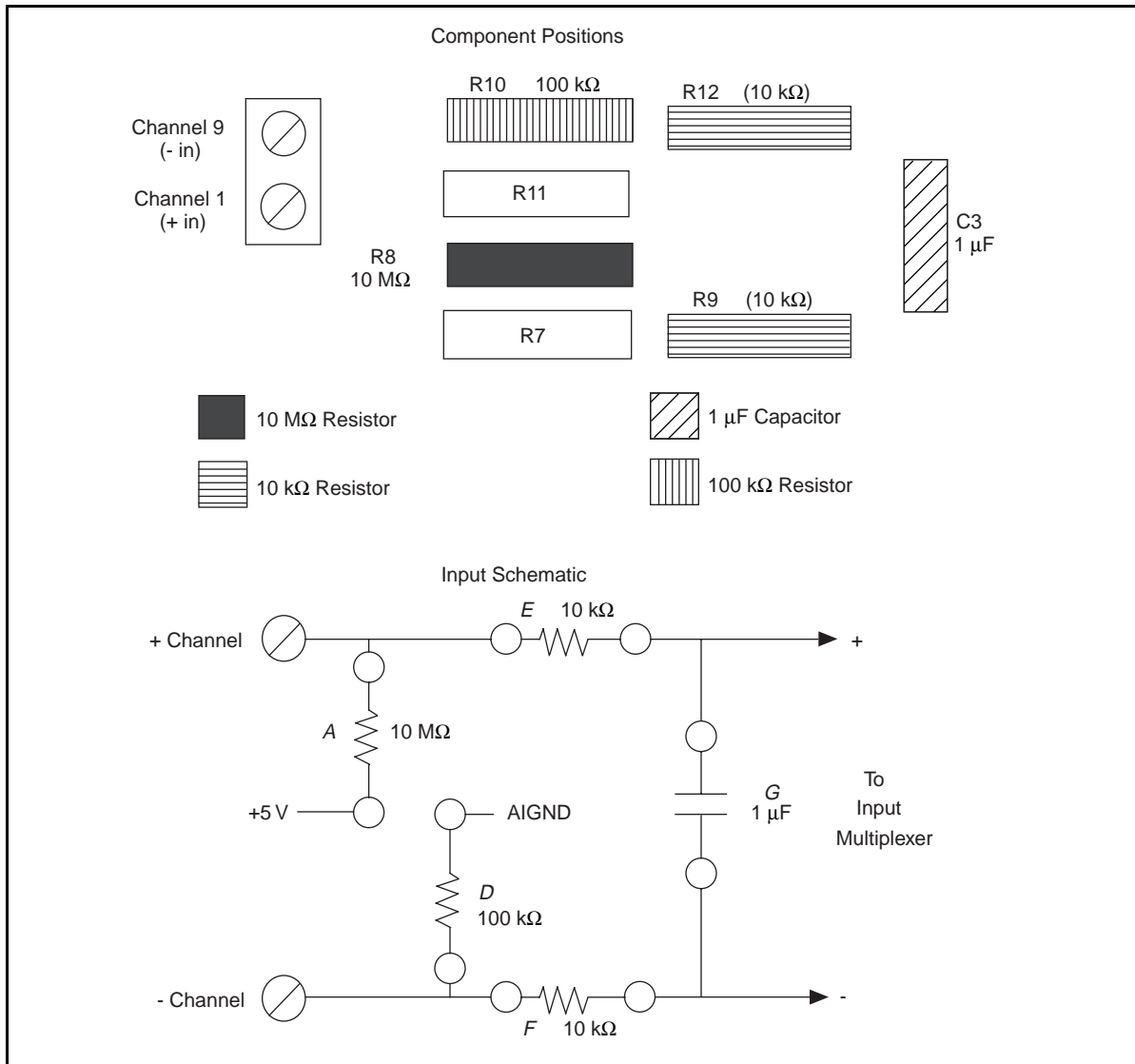

Figure 2-13. Thermocouple Circuit with Open Thermocouple Detect and Lowpass Noise Filter

Selecting the Gain and Input Ranges

Because thermocouple output voltages are very low, a gain of 500 or 100 is usually necessary for best resolution. The input range on the MIO-16 should be set to ± 5 V to improve resolution. These settings can be used in all but a few cases, such as a fairly high output thermocouple type that is being used at elevated temperatures. Table 2-3 lists the voltage extremes from several popular thermocouple types. Use this table as a guide for determining the best gain and input range settings to use.

Table 2-3. Thermocouple Voltage Output Extremes (mV)¹

Thermocouple	Low	High
J	-8.096 at -210° C ²	42.922 at 760° C ²
K	-6.548 at -270° C	54.807 at 1370° C
E	-9.835 at -270° C	76.358 at 1000° C
T	-6.258 at -270° C	20.869 at 400° C
S	0.000 at 0° C	18.612 at 1760° C
R	0.000 at 0° C	21.006 at 1760° C
B	-0.003 at 20° C	13.814 at 1820° C

¹ Source of information is *Omega Temperature Measurement Handbook & Encyclopedia*, Omega Engineering (Stamford, CT).

² All temperatures are the difference between the measuring end and the cold junction, or SC-2070 screw terminals in this case.

Linearizing the Data

Thermocouple output voltages are highly nonlinear. The *Seebeck coefficient*, or voltage change per degree of temperature change, can vary by a factor of three or more over the operating temperature range of some thermocouples. For this reason, the temperature from thermocouple voltages must either be approximated by polynomials or matched against a look-up table. The polynomial approach is easier to use, but it trades measurement time for memory usage. The polynomials are in the form:

$$T = a_0 + a_1x + a_2x^2 + \dots + a_nx^n \quad (\text{Formula 2-4})$$

where x is the thermocouple voltage in *volts*, T is the temperature difference between the measuring end and the SC-2070 screw terminals in degrees Celsius, and a_0 through a_n are coefficients specific to each thermocouple type. To speed computation time, a polynomial should be computed in nested form. Consider the fourth order polynomial:

$$T = a_0 + a_1x + a_2x^2 + a_3x^3 + a_4x^4 \quad (\text{Formula 2-5})$$

If this polynomial is evaluated as it is written, several unnecessary multiplications are performed to raise x to the various powers. On the other hand, if the polynomial is written and evaluated as follows, then no powers are computed, and execution proceeds much faster:

$$T = a_0 + x(a_1 + x(a_2 + x(a_3 + xa_4))) \quad (\text{Formula 2-6})$$

Table 2-4 lists the National Bureau of Standards (NBS) polynomial coefficients for several popular thermocouples.

Table 2-4. NBS Polynomial Coefficients

Type	E	J	K	R	S	T
Temp. Range	-100° to 1,000° C ± 0.5° C ¹	0° to 760° C ± 0.1° C ¹	0° to 1,370° C ± 0.7° C ¹	0° to 1,000° C ± 0.5° C ¹	0° to 1,750° C ± 1° C ¹	-160° to 400° C ± 0.5° C ¹
a ₀	0.104967248	-0.048868252	0.226584602	0.263632917	0.927763167	0.100860910
a ₁	17189.45282	19873.14503	24152.10900	179075.491	169526.5150	25727.94369
a ₂	-282639.0850	-218614.5353	67233.4248	-48840341.37	-31568363.94	-767345.8295
a ₃	12695339.5	11569199.78	2210340.682	1.90002E + 10	8990730663	78025595.81
a ₄	-448703084.6	-264917531.4	-860963914.9	-4.82704E + 12	-1.63565E + 12	-9247486589
a ₅	1.10866E + 10	2018441314	4.83506E + 10	7.62091E + 14	1.88027E + 14	6.97688E + 11
a ₆	-1.76807E + 11		-1.18452E + 12	-7.20026E + 16	-1.37241E + 16	-2.66192E + 13
a ₇	1.71842E + 12		1.38690E + 13	3.71496E + 18	6.17501E + 17	3.94078E + 14
a ₈	-9.19278E + 12		-6.33708E + 13	-8.03104E + 19	-1.56105E + 19	
a ₉	2.06132E + 13				1.69535E + 20	
¹ The accuracies shown apply only to the polynomial and do not take into consideration errors introduced by the SC-2070 board, the MIO-16 board, or the thermocouple itself.						

These polynomials are accurate only within the temperature ranges specified. Also, all terms must be included to achieve the specified accuracy.

To avoid the long computation time required for these high-order polynomials, the operating range of a thermocouple can be subdivided into several smaller ranges. Each of the smaller ranges can then be approximated by a much lower order polynomial, such as the polynomial in Formula 2-6. Further examples of polynomials, including lower-order polynomials for subdivided temperature ranges, can be found in NIST Monograph 175, *Temperature-Electromotive Force Reference Functions and Tables for the Letter-Designated Thermocouple Types Based on the ITS-90* (National Institute of Standards Technology, Gaithersburg, MD 20899).

Differential Measurements

Connect the temperature sensor to channel 0 and channel 8 (differential channel 0) by configuring jumper W1 as shown in Figure 2-3. Connect the thermocouples to the appropriate pairs of input channel screw terminals (for example, CH1 and CH9, CH2 and CH10, and so on). Notice that some thermocouples, such as those from Omega Engineering (Stamford, CT), have red insulation on the *negative* terminal. Check with the vendor to determine the output polarity of any particular thermocouple. Because thermocouples are floating signal sources, a bias-return resistor in the range of 10 to 100 k Ω must be attached between the (-) channel and GND, which is connected to the MIO-16 AIGND (analog input ground). For more information about signal sources and their connections, see Chapter 2 in your MIO-16 board user manual.

An Example of Using Thermocouples in Differential Mode

Assume that you are measuring the temperature of a high-pressure boiler system using a PC AT computer, an AT-MIO-16L board in differential mode, an SC-2070 board, and a J-type thermocouple. The maximum temperature that can be reached in this example is 300° C. Before taking readings, you must configure the AT-MIO-16L board for the maximum resolution possible. A thermocouple table shows that the output voltage never exceeds 16 mV to 17 mV (recall that the exact voltage measured is a function of the SC-2070 temperature as well as the temperature being measured). Therefore, either a ± 5 V input range with a gain of 100 (± 50 mV maximum signal) or a ± 10 V input range with a gain of 500 (± 20 mV maximum signal) can be selected. In this case, the ± 10 V input range with a gain of 500 gives the best resolution. Set the jumpers on the AT-MIO-16L for differential input, ± 10 V input range. Jumper W1 on the SC-2070 board is set to select the temperature sensor as shown in Figure 2-3. To connect the thermocouple to differential channel 1, connect one lead to the CH1 terminal and the other to the CH9 terminal. Notice that no thermocouples can be read on channel 0. A bias-return resistor in the range of 10 k Ω to 100 k Ω is soldered to R10 for the bias current return path. For this example, you do not add any lowpass filters or broken thermocouple detection.

The procedure for this example is as follows:

1. Read the voltage from the temperature sensor (channel 0). If you are using an NI-DAQ software package, you can use the `AI_Read` and `AI_Scale` functions to do the reading. The temperature sensor voltage is 10 mV/°C, so the gain should be either 1 or 10 (10 for the best resolution). Multiply the voltage by 100 to get the SC-2070 temperature in degrees Celsius. For example, if the reading is 0.25 V, the SC-2070 board is at 25° C.
2. Read the voltage on analog input channel 1, using a gain of 500. If you are using an NI-DAQ software package, you can use the `AI_Read` and `AI_Scale` functions to read the channel.
3. Translate the reading into an uncompensated temperature using either a look-up table or a polynomial such as that described in Formula 2-4. For example, assume that the reading from the thermocouple is 9.39 mV. By applying Formula 2-6 and the coefficients from Table 2-4, you can calculate that the uncompensated temperature is 175° C.
4. Add the cold-junction temperature from step 1 to the uncompensated temperature obtained in step 3. This result is the temperature at the measuring end of the thermocouple. For the example given, the temperature of the boiler system is 175° C + 25° C = 200° C.

Single-Ended Measurements

Connect the temperature sensor to channel 0 by configuring jumper W1 as shown in Figure 2-3. Connect the positive leads of the thermocouples to any SC-2070 input channels except CH0. Connect the negative leads to AIGND. Notice that some thermocouples, such as those from Omega Engineering (Stamford, CT), have red insulation on the *negative* terminal. Check with the vendor to determine the output polarity of any particular thermocouple. The MIO-16 board should be configured for ground-referenced, single-ended inputs. For more information about signal sources and their connections, see Chapter 2 in your MIO-16 board user manual.

An Example of Using Thermocouples in Single-Ended Mode

Assume that you are measuring the temperature of a high-pressure boiler system with a PC AT computer, an AT-MIO-16L in single-ended mode, an SC-2070 board, and a J-type thermocouple. The maximum temperature that can be reached in this example is 300° C. Before taking readings, you must configure the AT-MIO-16L board for the maximum resolution possible. A thermocouple table shows that the output voltage never exceeds 16 to 17 mV (recall that the exact voltage measured is a function of the SC-2070 temperature as well as the temperature being measured). Therefore, either a ± 5 V input range with a gain of 100 (± 50 mV maximum signal) or a ± 10 V input range with a gain of 500 (± 20 mV maximum signal) can be selected. In this case, the ± 10 V input range with a gain of 500 gives the best resolution. Set the jumpers on the AT-MIO-16L for single-ended input, ± 10 V input range. Jumper W1 on the SC-2070 board is set to select the temperature sensor, as shown in Figure 2-3. To connect the thermocouple to single-ended channel 1, connect the positive thermocouple lead to channel 1 and the negative thermocouple lead to AIGND. For this example, you do not add any lowpass filters or broken thermocouple detection.

The procedure for this example is as follows:

1. Read the voltage from the temperature sensor. If you are using an NI-DAQ software package, you can use the `AI_Read` and `AI_Scale` functions to do the reading. The temperature sensor voltage is the voltage on channel 0. This voltage is 10 mV/°C, so the gain should be either 1 or 10 (10 for the best resolution). Multiply the voltage by 100 to get the SC-2070 temperature in degrees Celsius. For example, if the reading is 0.25 V, then the SC-2070 is at 25° C.
2. Read the voltage on analog input channel 1, using a gain of 500. If you are using an NI-DAQ software package, you can use the `AI_Read` and `AI_Scale` functions to read the channel.
3. Translate the reading into an uncompensated temperature using either a look-up table or a polynomial such as that described in Formula 2-4. For example, assume that the reading from the thermocouple is 9.39 mV. By applying Formula 2-6 and the coefficients from Table 2-4, you can calculate that the uncompensated temperature is 175° C.
4. Add the cold-junction temperature from step 1 to the uncompensated temperature obtained in step 3. This result is the temperature at the measuring end of the thermocouple. For the example given, the temperature of the boiler system is 175° C + 25° C = 200° C.

Sources of Error

When making thermocouple measurements with the SC-2070 board and an MIO-16 board, the possible sources of error are compensation, linearization, measurement, and thermocouple wire errors.

Compensation error can arise from two sources: inaccuracy of the temperature sensor and temperature differences between the sensor and the screw terminals. The sensor used on the SC-2070 board is specified to be accurate to $\pm 1^\circ\text{C}$. Minimize temperature differences between the sensor and the screw terminals by keeping the SC-2070 board away from drafts, heaters, and warm equipment.

Linearization error is a consequence of the polynomials being approximations of the true thermocouple output. The linearization error is dependent on the degree of polynomial used. Table 2-4 lists the linearization errors for the NBS polynomials.

Measurement error is the result of inaccuracies in the MIO-16. These inaccuracies include gain and offset. If the board is properly calibrated, the offset error should be zeroed out. The only remaining error is a gain error of $\pm 0.08\%$ of full range (see the MIO-16 specifications). If the input range is $\pm 10\text{ V}$ and the gain is 500, gain error contributes $0.0008 \times 20\text{ mV}$, or $16\ \mu\text{V}$ of error. If the Seebeck coefficient of a thermocouple is $32\ \mu\text{V}/^\circ\text{C}$, this measurement error adds 0.5°C of uncertainty to the measurement. For best results, use a well-calibrated MIO-16 board so that offsets can be neglected. Offset error can be eliminated, however, by grounding one channel on the SC-2070 board and measuring the voltage. This value, the offset of the MIO-16, can then be subtracted in software from all other readings.

Thermocouple wire error is the result of inconsistencies in the thermocouple manufacturing process. These inconsistencies, or nonhomogeneities, are the result of defects or impurities in the thermocouple wire. The errors vary widely depending on the thermocouple type and even the wire gauge used, but a value of $\pm 2^\circ\text{C}$ is typical.

For best results, use an average of about 100 readings. When using an average, typical accuracies are about $\pm 2^\circ\text{C}$.

Thermocouple Measurement Accuracies

Table 2-5 lists the expected thermocouple accuracies in degrees Celsius, subject to the following conditions:

- The MIO-16 board is correctly calibrated.
- The temperature of the screw terminals equals the temperature of the board (no gradients on the board).

The uncertainties listed apply at either 0°C (Type J, K, E, T) or 600°C (Type S, R). The linearization errors of the NBS polynomials in Table 2-4, measurement error of a calibrated MIO-16, and the $\pm 1^\circ\text{C}$ cold-junction sensor error are included. Thermocouple wire error is neglected because of a dependence on the conditions listed previously. Finally, these uncertainties are for the gains listed with a $\pm 10\text{ V}$ input range.

Table 2-5. Thermocouple Measurement Accuracies

	Type					
Gain	J	K	E	T	S	R
100	±2.7° C	±3.7° C	±2.9° C	±3.6° C	±9.8° C	±8.5° C
500	±1.4° C	±2.1° C	±1.8° C	±1.9° C	±3.6° C	±2.9° C

Additional Signal Connection Information

For more information about signal connections, see Chapter 2 in your MIO-16 board user manual.

Chapter 3

SC-2071 Board

This chapter describes the SC-2071 board in detail, including function, compatibility, connection, mounting, and applications. This chapter also discusses working with thermocouples.

The SC-2071 is a general-purpose termination breadboard that makes it easy to connect to all Lab/1200 device I/O signals; add analog input signal conditioning, such as filters, dividers, and thermocouple compensation; and build external, custom timing, analog, and digital circuits.

The SC-2071 board is used with the National Instruments Lab/1200 devices for the Macintosh, IBM PC/XT/AT, and compatible computers.

The SC-2071 board has screw terminals for eight single-ended input channels. Open component positions at each analog input facilitate the addition of user-selected signal conditioning. The SC-2071 board has an onboard temperature sensor that can be optionally jumpered to channel 0 for thermocouple cold-junction compensation. With open component positions in the input paths, you can insert user-supplied resistors and capacitors for conditioning the eight single-ended analog input signals. A 4 by 1.5 in. general-purpose breadboard area is also included. The SC-2071 board also has screw terminals for all of the other signals from the DAQ device. With these terminals, the board easily connects to digital, timing, and trigger signals. The SC-2071 has two 50-pin I/O connectors, J1 and J2. Connector J2 is designated for daisy-chaining DAQ signals. Figure 3-1 shows the parts locator diagram for the SC-2071 board.

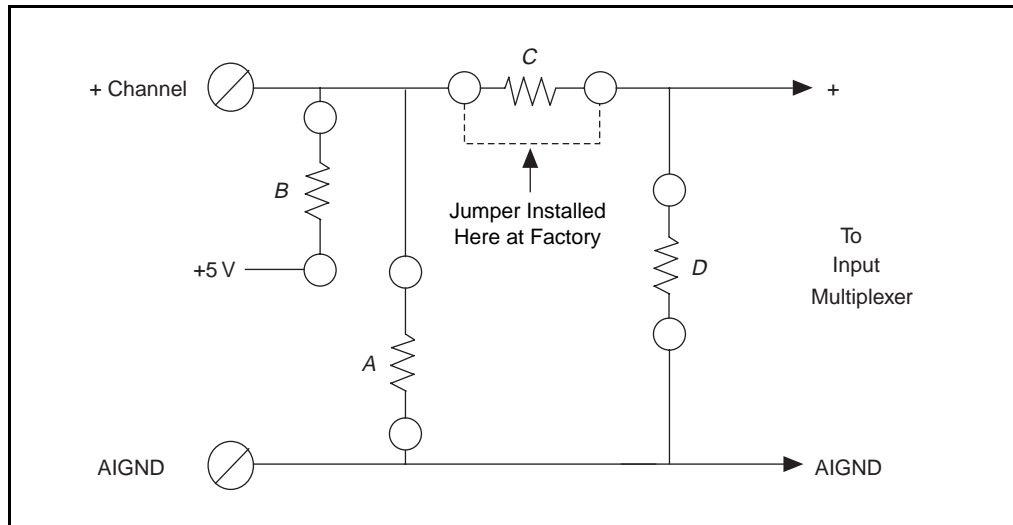

Figure 3-2. Onboard Equivalent Circuit

The components are numbered differently for each channel. Table 3-1 is a list of the components in each channel and their correspondence to the circuit shown in Figure 3-2.

Table 3-1. Component Positions in Each Channel

Channel	(Position in Figure 3-2)			
	A	B	C	D
0	R1	R3	R2	R4
1	R5	R7	R6	R8
2	R9	R11	R10	R12
3	R13	R15	R14	R16
4	R17	R19	R18	R20
5	R21	R23	R22	R24
6	R25	R27	R26	R28
7	R29	R31	R30	R32

When the board is shipped, a jumper is inserted in the C position of the input network. You can easily remove the jumper to build analog input signal conditioning circuits. A few specific applications showing the use of these open component positions are discussed in *Applications* later in this chapter.

Temperature Sensor

The SC-2071 board is equipped with an onboard temperature sensor for use with thermocouple cold-junction compensation. This sensor, a National Semiconductor LM-35CZ, generates a voltage output of 10 mV/°C, with an accuracy of $\pm 1^\circ\text{C}$. The sensor is jumper-enabled on input channel 0. Jumper W1 is used to choose either the temperature sensor or the external screw terminals as the input source for channel 0. If the temperature sensor is chosen, any signal conditioning that has been installed on channel 0 is ignored and has no effect. Figure 3-3 shows the positions for jumper W1.

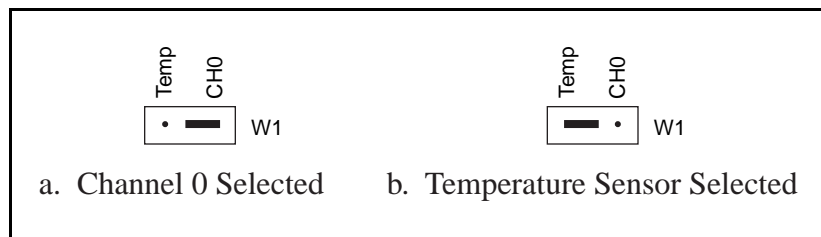

Figure 3-3. W1 Jumper Settings

Shield Ground

Jumper W2 is used to connect digital ground (DGND) to a grounded metal case. This option is useful only if the SC-2071 board is on metal standoffs and mounted in a grounded metal case. You can select shield grounding to reduce noise. Figure 3-4 shows the jumper settings for W2.

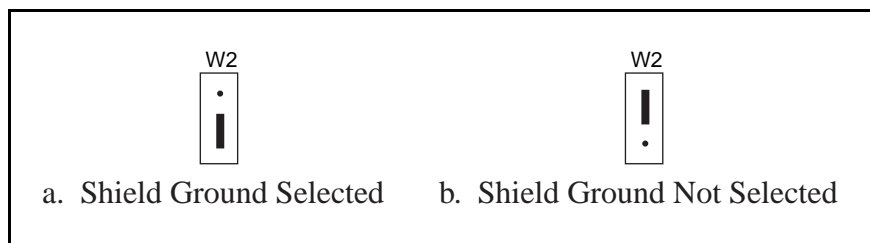

Figure 3-4. W2 Jumper Settings

Fuse and Power LED

The +5 V line from the DAQ device is protected by an 800 mA fuse. If the red power LED does not light when the DAQ device is powered on, check both the 800 mA fuse on the SC-2071 board and the output fuse (if any) on the Lab/1200 device. Information on power connection is given in Chapter 5, *Installation and Connections*.

Digital and Timing Signals

All of the signals from the Lab/1200 device are made available at screw terminals on the SC-2071 board. Because these signals are not conditioned or changed in any way by this board, refer to your Lab/1200 device user manual for information on the use of these signals. If you want optical isolation of or relay control by the digital I/O lines, you must use a National Instruments SC-2053 cable adapter board and the appropriate SC-206X Series digital signal conditioning board. For more information on these products, refer either to your National Instruments catalog, the *SC-205X Series User Manual*, or the *SC-206X Series User Manual*.

Board-to-Board Cabling

The SC-2071 board connects directly to any of the DAQ devices listed in Table 3-2.

Table 3-2. DAQ Devices Used with the SC-2071 Board

	Lab/1200 Device (PC/XT and Macintosh)
SC-2071 Board	Lab LC ¹ Lab-NB Lab-PC Lab-PC+ DAQCard-1200 ² DAQPad-1200 PCI-1200
¹ Requires an NB10 cable, available separately. ² Requires a PR50-50F cable, available separately.	

The SC-2071 board has two functionally equivalent 50-pin I/O connectors. Connect one connector directly to the Lab/1200 device or to the SC-2053 cable adapter board with the included 50-conductor NB1 cable. A direct connection is shown in Figure 3-5. If you are using the SC-2071 board with the Lab-LC board, an NB10 cable connects the Lab-LC board to the SC-2071 board. If you are using the SC-2071 board with the DAQCard-1200, a PR50-50F cable connects the DAQCard-1200 to the SC-2071 board. The second connector is used for daisy-chaining to the BNC-2081 as shown in Figure 3-6.

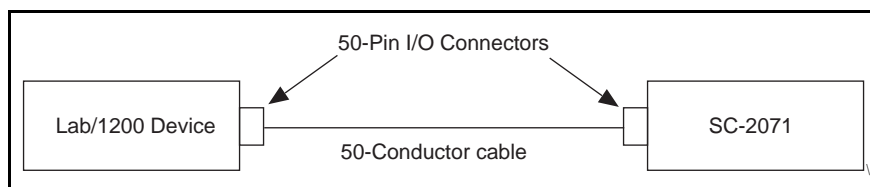

Figure 3-5. Direct Connection between a Lab/1200 device and the SC-2071 Board

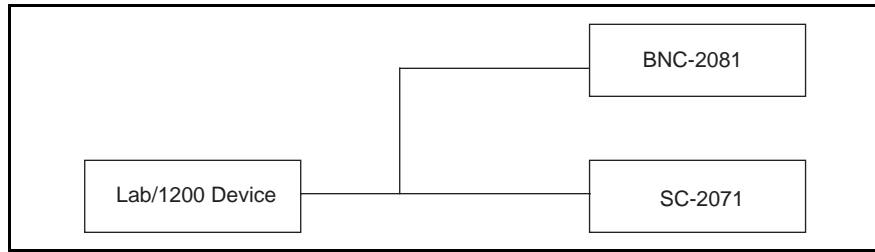

Figure 3-6. Daisy-chaining a Lab/1200 device to a BNC-2081

For digital signal conditioning with the National Instruments SC-206X Series boards, the SC-2053 cable adapter board must be used with the Lab-NB or Lab-PC. Figure 3-7 shows a connection using the SC-2053 cable adapter board.

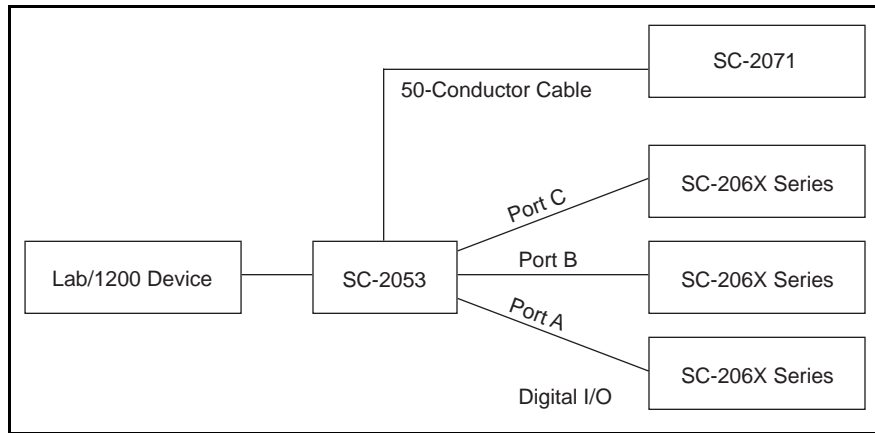

Figure 3-7. Connection between a Lab/1200 device and the SC-2071 Board via the SC-2053 Board

Warning: *Do not connect the SC-2071 board to any device other than a National Instruments Lab/1200 device or the SC-2053 cable adapter board. The SC-2071 board is not compatible with any other DAQ devices or cable adapter boards. Attempts to use the SC-2071 board with products for which it was not intended can result in damage to the SC-2071 board, the DAQ device, or the host computer. National Instruments is NOT liable for damages resulting from these connections.*

The SC-2071 board uses a 50-pin ribbon cable connector to connect to the 50-pin I/O connector on either a Lab/1200 device, an SC-2053 cable adapter board, or the BNC-2081 analog breakout board. If the SC-2053 cable adapter board is being used, the SC-2053 connects to the DAQ device with a 50-conductor ribbon cable. The SC-2071 board then connects to the other 50-pin I/O connector on the SC-2053. If you are using the BNC-2081 analog breakout board, connect the BNC-2081 to the SC-2071 board with a 50-conductor ribbon cable. Make sure you do not connect voltage signals to the same analog input or analog output channels on both the SC-2071 and the BNC-2081. For more information, see Chapter 5, *Installation and Connections*.

Mounting

The SC-2071 board is equipped with metal standoffs so the board can be placed on a workbench near the host computer. You can use an optional rack-mount chassis, which can be fitted with a flat, acrylic plastic cover. When the SC-2071 board is mounted in the chassis, the board can be grounded to its metal standoffs, and therefore to the rack. For more information, see Chapter 5, *Installation and Connections*.

Applications

The open component positions on the SC-2071 board make adding signal conditioning components to the analog input signals easier. Several applications are covered in this section, including thermocouple readings, filtering, and attenuation.

The figures in this section give examples on a specific input channel. To install the circuit on a different channel, consult Table 3-1 to determine the equivalent component positions for the other channels.

Soldering and Desoldering on the SC-2071 Board

With the applications discussed here, you must modify the printed circuit board, usually in the form of removing jumpers and adding components. The SC-2071 board is shipped with one jumper in the C position (see Table 3-1 and Figure 3-2). Use a low-wattage soldering iron (20 to 30 W) when soldering to the board. To desolder on the SC-2071, vacuum-type tools work best. Use care when desoldering to avoid damaging component pads. Only use rosin-core electronic grade solder. Acid-core solder damages the printed circuit board and components.

Connecting Floating Signal Sources

A floating signal source is a signal source that is not connected in any way to the building ground system, but has an isolated ground reference point. If an instrument or device has an isolated output, that instrument or device falls into the floating signal source category. Some examples of floating signal sources are outputs for the following: thermocouples, transformers, battery-powered devices, optical isolators, and isolation amplifiers. The ground reference of a floating source must be tied to the ground of the DAQ device.

No special components are needed to measure signals from floating sources connected to the SC-2071 board. Because the negative side of the single-ended inputs is grounded, all floating sources are referenced to the same ground. The SC-2071 board inputs can be left in the factory-original condition, that is, with a jumper in the series position, *C* (see Table 3-1). Signal conditioning circuitry, such as the filters and attenuators described in *Building Lowpass Filters*, *Building Highpass Filters*, and *Building Attenuators* later in this chapter, can be used.

Connecting Grounded Signal Sources

A grounded signal source is connected in some way to the building system ground; therefore, the signal source is already connected to a common ground point with respect to the DAQ device (assuming the host computer is plugged into the same power system). Nonisolated outputs of instruments and devices that plug into the building power system fall into this category.

In the case of grounded signal sources connected to the single-ended inputs of the SC-2071 board, a small DC error can be measured because of differences between the ground potentials of the signal source and the Lab/1200 device. This error is unavoidable with the SC-2071 board because the Lab/1200 device is configured only for ground-referenced, single-ended inputs. You need no special components to measure signals from grounded sources connected to the SC-2071 board. The inputs of the SC-2071 board can be left in the factory-original condition, that is, with only a jumper in the series position *C* (see Table 3-1 and Figure 3-2). Signal conditioning circuitry such as the filters and attenuators described in *Building Lowpass Filters*, *Building Highpass Filters*, and *Building Attenuators* later in this chapter, can be used.

Building Lowpass Filters

You can easily install simple, RC lowpass filters in the SC-2071 board on any input channel. The filters are useful for accurate measurement and noise rejection. By substituting resistance and capacitance values into the following formula, you can calculate a simple, one-pole RC filter to have a -3 dB point (cutoff frequency):

$$f_c = \frac{1}{2\pi RC} \quad (\text{Formula 3-1})$$

The frequency response rolls off at a rate of -20 dB per decade of increase thereafter. A Bode plot of the amplitude versus normalized frequency is shown in Figure 3-8.

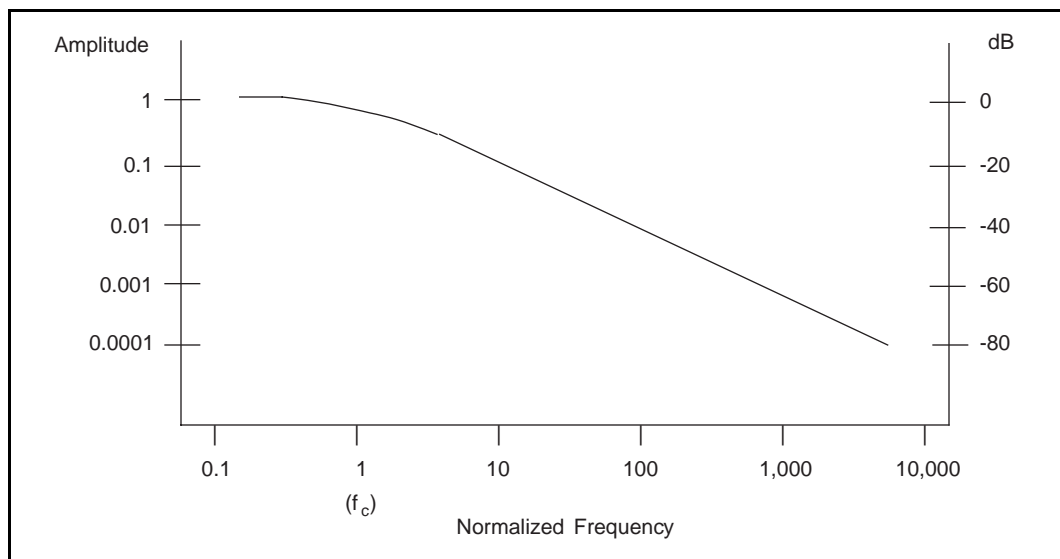

Figure 3-8. Normalized Frequency Response of Lowpass Filter

When measuring low-frequency signals (about 4 Hz), if you have 400-Hz noise on your inputs, you can add a lowpass filter with a cutoff frequency of 4 Hz. The 400-Hz noise then attenuates by 40 dB. Notice that your 4-Hz signal also attenuates, but by only 3 dB. Do not neglect any potential attenuation of signals of interest by this low-order filter.

You must also choose the filter component values. The resistance or the capacitance can be selected arbitrarily; one value determines the other. Picking the capacitor first and letting its value determine the resistance required is preferable because more standard resistor values are available. If a capacitance of 1 μF is available, then the resistance is (by substitution into Formula 3-1) 39,789 Ω , or about 39.80 k Ω . Therefore, in this example, the input has a 39.80 k Ω resistor (or closest standard value) in its series position, *C*. The closest standard 5% tolerance resistor is 39 k Ω . For a lowpass filter on a single-ended input, 5% tolerance resistors suffice. Figure 3-9 shows both the schematic and the component placement for a 4-Hz lowpass filter placed on channel 1.

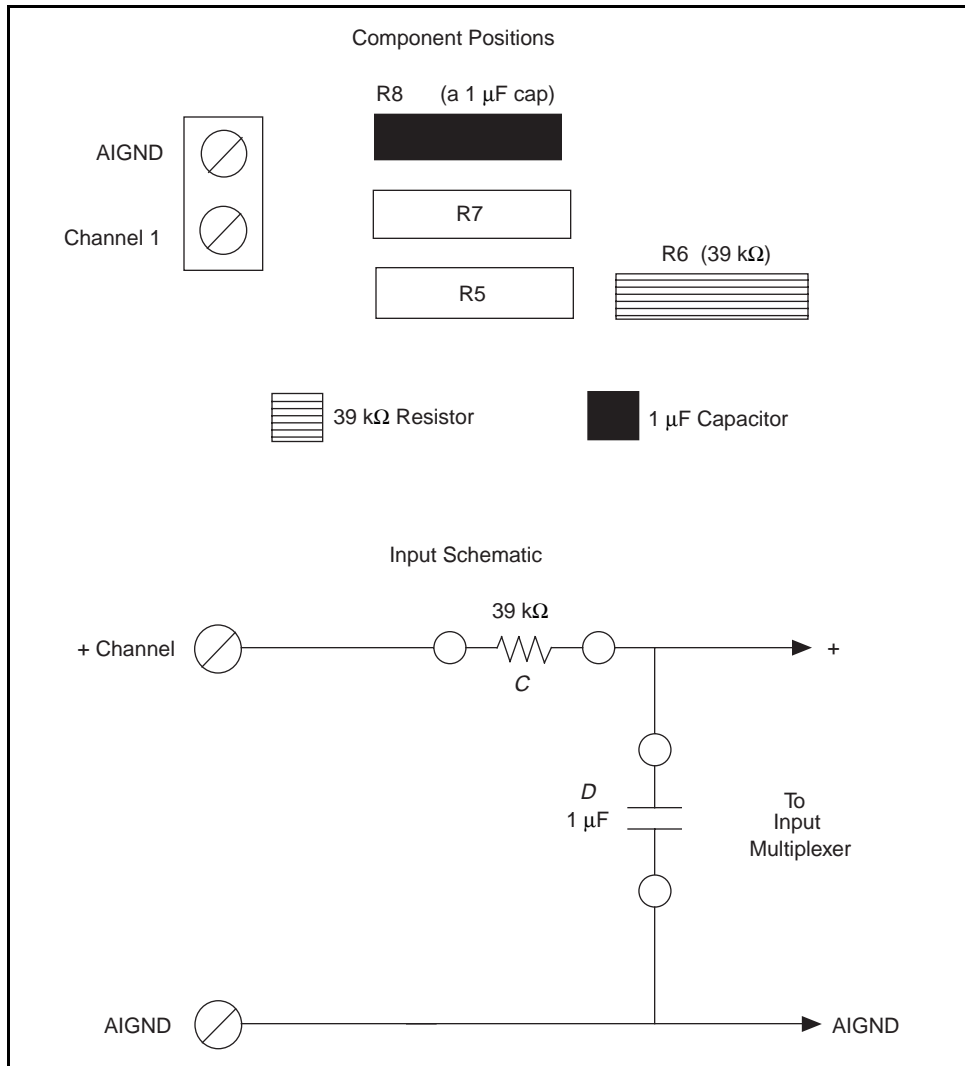

Figure 3-9. Lowpass Filter on Channel 1

Building Highpass Filters

You can easily install simple, RC highpass filters in the SC-2071 board on any input channel. The filters are useful for accurate high-frequency measurement and low-frequency noise rejection. By substituting resistance and capacitance values into the following formula, you can calculate a simple, one-pole RC filter to have a -3 dB point (cutoff frequency):

$$f_c = \frac{1}{(2\pi RC)} \quad \text{(Formula 3-2)}$$

The response rolls off at a rate of -20 dB per decade drop in frequency thereafter. A Bode plot of the amplitude versus normalized frequency is shown in Figure 3-10.

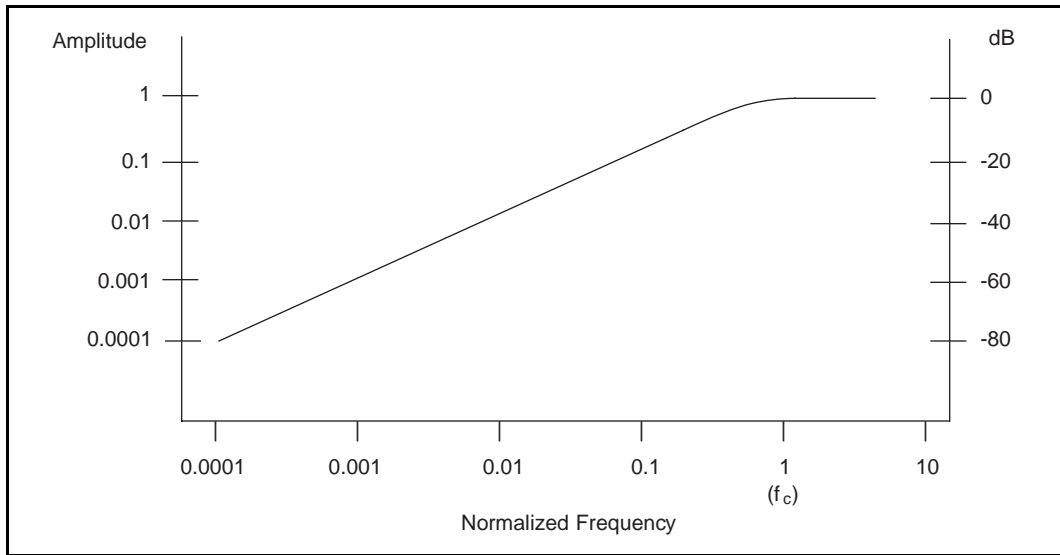

Figure 3-10. Normalized Frequency Response of Highpass Filter

When measuring high-frequency signals (about 20 kHz), if you have 20-Hz noise on your inputs, you can add a highpass filter with a cutoff frequency of 20 kHz. The 20-Hz noise then attenuates by 60 dB. Notice that your 20-kHz signal also attenuates, but by only 3 dB. Do not neglect any potential attenuation of signals of interest by this low-order filter.

You must also choose the filter component values. The resistance or the capacitance can be selected arbitrarily; one value determines the other. Picking the capacitor first and letting its value determine the resistance required is preferable because more standard resistor values are available. If a 0.001 μF capacitor is available, the resistance is (by substitution into Formula 3-2) 7958 Ω , or about 8.0 k Ω . Therefore, in this example, the input channel has a 7.96 k Ω resistor (or closest standard value) in position *D* and a 0.001 μF capacitor in position *C*. The closest standard 5% tolerance resistor is 8.2 k Ω . Resistor tolerance is not a concern in this application because most capacitors have poor tolerances (for example, 20% to 30%). Figure 3-11 shows both the schematic and the component placement for a 20-kHz highpass filter placed on input channel 1.

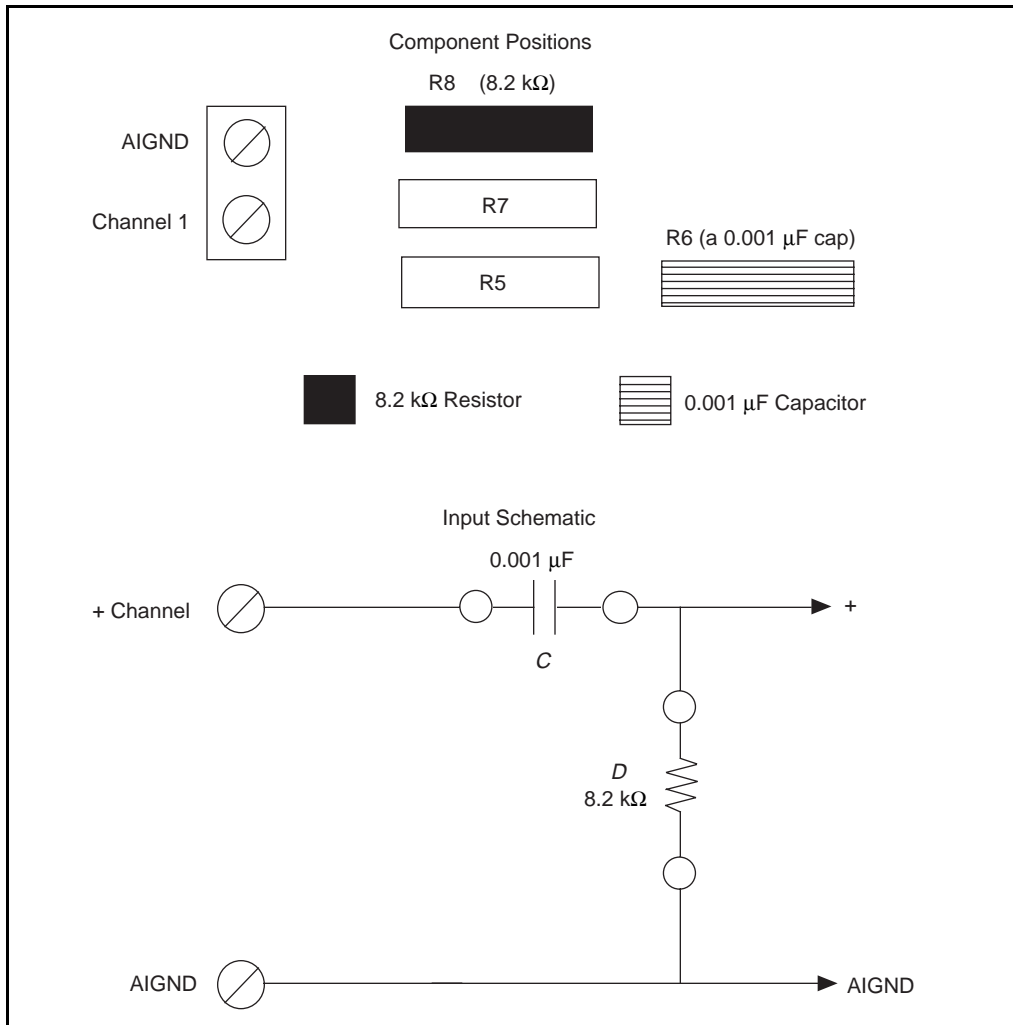

Figure 3-11. Highpass Filter on Channel 1

Building Attenuators (Voltage Dividers)

You can connect attenuators (voltage dividers) to the analog inputs of the SC-2071 board. Attenuators can be used to reduce a signal that is outside the normal input range of the DAQ device (± 10 V maximum).

Warning: *The SC-2071 board is not designed for any input voltages greater than 42 V, even if a user-installed voltage divider reduces the voltage to within the input range of the DAQ device. Input voltages greater than 42 V can result in damage to the SC-2071 board, any and all devices connected to it, and the host computer. Overvoltage can also cause an electric shock hazard for the operator. National Instruments is NOT liable for damage or injury resulting from such misuse.*

A two-resistor circuit for attenuating voltages at the single-ended inputs of the SC-2071 board is shown in Figure 3-12. The Figure also shows the placement of the resistors on the open component positions for channel 1. The gain, G , of this attenuator is given by the following formula:

$$G = \frac{R_D}{(R_C + R_D)} \quad (\text{Formula 3-3})$$

Therefore, the input to the Lab/1200 device (V_{Lab}) is

$$V_{\text{Lab}} = V_{\text{SC}} * G$$

where V_{SC} is the voltage applied to the screw terminals of the SC-2071 board. The accuracy of this gain equation depends on the tolerances of the resistors used.

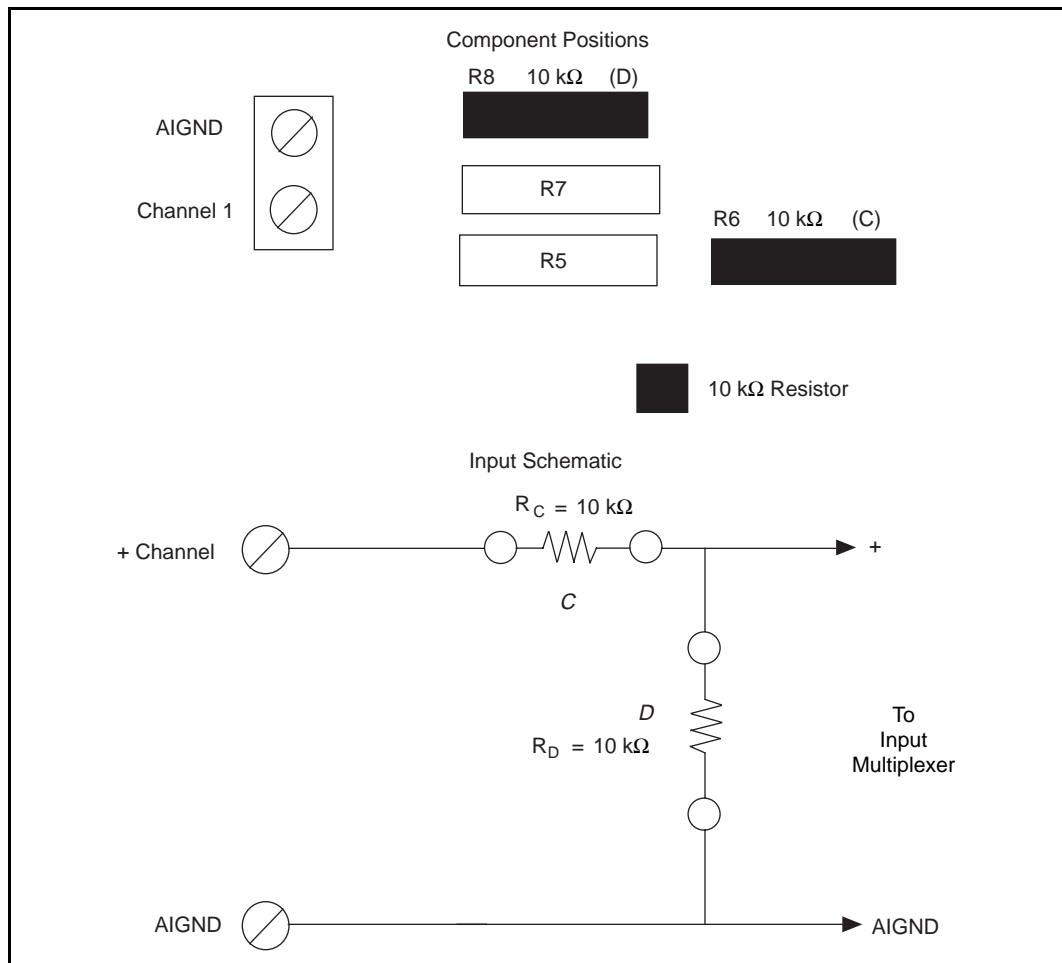

Figure 3-12. Attenuator for Use with SC-2071 Board Inputs

Example:

Using the values in Figure 3-12,

$$G = \frac{10 \text{ k}\Omega}{10 \text{ k}\Omega + 10 \text{ k}\Omega} = \frac{1}{2}$$

Therefore, $V_{\text{Lab}} = (1/2) V_{\text{SC}}$

With the Lab/1200 device configured for $\pm 5 \text{ V}$ inputs, the device can acquire $\pm 10 \text{ V}$ signals with this attenuator circuit.

Working with Thermocouples

One of the most frequently used temperature transducers is the thermocouple. A thermocouple is created whenever two dissimilar metals are brought in contact, and the contact produces a small voltage as a function of temperature. In most measurement situations, a thermocouple is placed where the temperature is to be measured; then two wires, consisting of the same type of metal as each side of the thermocouple, are run back to a termination panel such as the SC-2071 board. Additional dissimilar junctions are formed where these wires contact the screw terminals. Each of these junctions generates its own temperature-dependent voltage. Other temperature-dependent voltages are generated at ribbon cable junctions and solder joints. However, the effects of these junctions are negligible and tend to cancel in most cases. The voltage measured by the DAQ device is the sum of the voltages of *all* dissimilar metal junctions in the circuit, not just the thermocouple junction used to measure temperature.

Only the temperature of the screw terminal junctions must be known to compensate for all dissimilar metal junctions in a system with constant temperature (Thermocouple Law of Intermediate Metals). Therefore, if you know the temperature at the screw terminals, you can easily calculate the temperature at the point of interest from the voltage measured. A National Semiconductor LM-35CZ is used on the SC-2071 board to determine the temperature of the screw terminals. The dissimilar metal junctions at the screw terminals are also referred to as the *cold junction*, and the process of using the known temperature at that point to find the temperature at the unknown point is called *cold-junction compensation* (CJC).

Thermocouples are usually more desirable than direct-reading sensors for several reasons. Thermocouples are more rugged than most other sensors, and can tolerate several hundred degree temperatures without degradation. Semiconductor sensors, the easiest to use, usually cannot be used above 70°C . Thermocouples are inexpensive and physically small, a feature that enables them to track temperature changes rapidly.

Thermocouple output voltages are very low, on the order of $50 \mu\text{V}/^\circ\text{C}$. The temperature coefficient changes with temperature, resulting in a nonlinear curve. The temperature can be determined from tables available from thermocouple vendors or calculated from polynomial equations such as those given in the next section.

Using the SC-2071 Board for Thermocouple Measurements

The maximum voltage level generated by thermocouples is typically a few millivolts. Therefore, a Lab-NB or Lab-PC with a gain of 100 (the highest possible) should be used for best resolution. Cold-junction compensation with the SC-2071 board is accurate only if the temperature sensor reading is close to the actual temperature of the screw terminals. Therefore, when thermocouples are being read, keep the SC-2071 board away from drafts or other temperature gradients such as those caused by heaters, radiators, fans, and warm equipment.

Input Filtering and Broken Thermocouple Detection (Optional)

To reduce noise, you can connect a lowpass filter. Refer to *Building Lowpass Filters* earlier in this chapter for an explanation of how to design these filters.

Broken thermocouple detection circuitry is built by connecting a high-value resistor between the positive input and +5 V. The value of this resistor is relatively unimportant; a few megohms or above works fine. With a high-value resistor, you can detect an open or defective thermocouple. If the thermocouple opens, the voltage measured across the input terminals rises to +5 V, a value much larger than any legitimate thermocouple voltage. A sample circuit and the component placement for a lowpass filter and broken thermocouple detection are shown in Figure 3-13, assuming that the thermocouple is connected to channel 1.

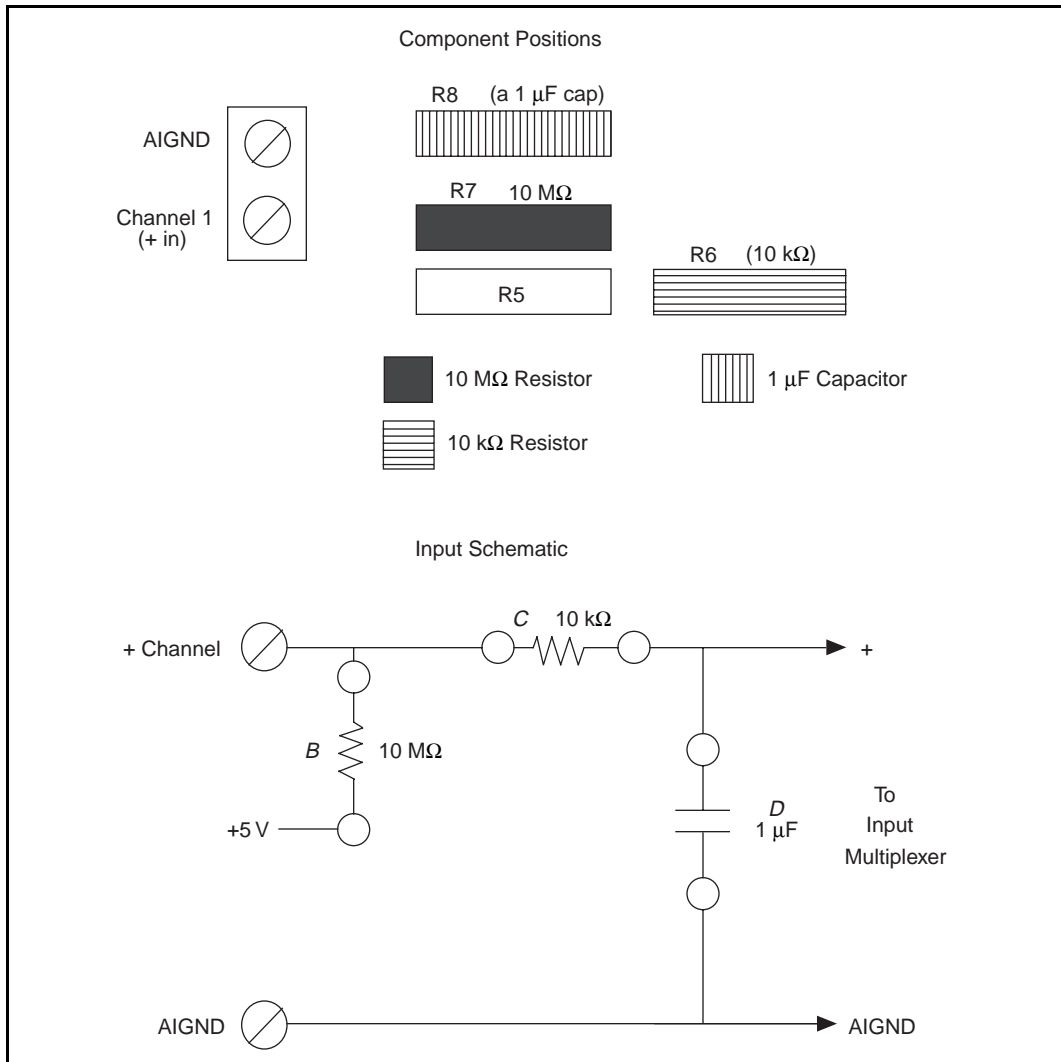

Figure 3-13. Thermocouple Circuit with Open Thermocouple Detect and Lowpass Noise Filter

Selecting the Gain and Input Ranges

Because thermocouple output voltages are very low, a gain of 100 is usually necessary for best resolution. The input range on the Lab/1200 device should usually be set to ± 5 V to improve resolution. These settings can be used in all but a few cases, such as a fairly high output thermocouple type used at elevated temperatures. Table 3-3 lists the voltage extremes from several popular thermocouple types. Use this Table as a guide for determining the best gain and input range settings to use. If the thermocouples are being used in a known temperature range, consult a book of thermocouple tables to determine the approximate millivolt output and the best gain and input range settings.

Table 3-3. Thermocouple Voltage Output Extremes (mV)¹

Thermocouple	Low	High
J	-8.096 at -210° C ²	42.922 at 760° C ²
K	-6.548 at -270° C	54.807 at 1370° C
E	-9.835 at -270° C	76.358 at 1000° C
T	-6.258 at -270° C	20.869 at 400° C
S	0.000 at 0° C	18.612 at 1760° C
R	0.000 at 0° C	21.006 at 1760° C
B	-0.003 at 20° C	13.814 at 1820° C

¹ Source of information is *Omega Temperature Measurement Handbook & Encyclopedia*, Omega Engineering (Stamford, CT).
² All temperatures are the difference between the measuring end and the cold junction, or SC-2071 board screw terminals in this case.

Linearizing the Data

Thermocouple output voltages are highly nonlinear. The *Seebeck coefficient*, or voltage change per degree of temperature change, can vary by a factor of three or more over the operating temperature range of some thermocouples. For this reason, the temperature from thermocouple voltages must either be approximated by polynomials or matched against a look-up table. The polynomial approach is easier to use, but it trades measurement time for memory usage. The polynomials are in the form:

$$T = a_0 + a_1x + a_2x^2 + \dots + a_nx^n \quad (\text{Formula 3-4})$$

where x is the thermocouple voltage in *volts*, T is the temperature difference between the measuring end and the SC-2071 board screw terminals in degrees Celsius, and a_0 through a_n are coefficients that are specific to each thermocouple type. To speed computation time, a polynomial should be computed in nested form. Consider the fourth order polynomial:

$$T = a_0 + a_1x + a_2x^2 + a_3x^3 + a_4x^4 \quad (\text{Formula 3-5})$$

If this polynomial is evaluated as it is written, then several unnecessary multiplications are performed to raise x to the various powers. On the other hand, if the polynomial is written and evaluated as follows, no powers are computed, and execution proceeds much faster:

$$T = a_0 + x(a_1 + x(a_2 + x(a_3 + xa_4))) \quad (\text{Formula 3-6})$$

Table 3-4 lists the NBS polynomial coefficients for several popular thermocouples.

Table 3-4. NBS Polynomial Coefficients

Type	E	J	K	R	S	T
Temp. Range	-100° to 1,000° C ± 0.5° C ¹	0° to 760° C ± 0.1° C ¹	0° to 1,370° C ± 0.7° C ¹	0° to 1,000° C ± 0.5° C ¹	0° to 1,750° C ± 1° C ¹	-160° to 400° C ± 0.5° C ¹
a ₀	0.104967248	-0.048868252	0.226584602	0.263632917	0.927763167	0.100860910
a ₁	17189.45282	19873.14503	24152.10900	179075.491	169526.5150	25727.94369
a ₂	-282639.0850	-218614.5353	67233.4248	-48840341.37	-31568363.94	-767345.8295
a ₃	12695339.5	11569199.78	2210340.682	1.90002E + 10	8990730663	78025595.81
a ₄	-448703084.6	-264917531.4	-860963914.9	-4.82704E + 12	-1.63565E + 12	-9247486589
a ₅	1.10866E + 10	2018441314	4.83506E + 10	7.62091E + 14	1.88027E + 14	6.97688E + 11
a ₆	-1.76807E + 11		-1.18452E + 12	-7.20026E + 16	-1.37241E + 16	-2.66192E + 13
a ₇	1.71842E + 12		1.38690E + 13	3.71496E + 18	6.17501E + 17	3.94078E + 14
a ₈	-9.19278E + 12		-6.33708E + 13	-8.03104E + 19	-1.56105E + 19	
a ₉	2.06132E + 13				1.69535E + 20	
¹ The accuracies shown apply only to the polynomial and do not take into consideration errors introduced by the SC-2071 board, the Lab/1200 device, or the thermocouple itself.						

These polynomials are accurate only within the temperature ranges specified. Also, all terms must be included to achieve the specified accuracy.

To avoid the long computation time required for these high-order polynomials, you can subdivide the operating range of a thermocouple into several smaller ranges. Each of the smaller ranges can then be approximated by a much lower order polynomial, such as the polynomial in Formula 3-6. Further examples of polynomials, including lower-order polynomials for subdivided temperature ranges, can be found in NIST Monograph 175, *Temperature-Electromotive Force Reference Functions and Tables for the Letter-Designated Thermocouple Types Based on the ITS-90* (National Institute of Standards and Technology, Gaithersburg, MD 20899).

Measurement Connections

Connect the temperature sensor to channel 0 by configuring jumper W1 as shown in Figure 3-3. Connect the positive leads of the thermocouples to any SC-2071 board input channels except CH0. Connect the negative leads to AIGND. Notice that some thermocouples, such as those from Omega Engineering (Stamford, CT), have red insulation on the *negative* terminal. Check with the vendor to determine the output polarity of any particular thermocouple. For more information about signal sources and their connections, see Chapter 2 in your Lab/1200 device user manual.

An Example of Using Thermocouples

Assume that you are measuring the temperature of a high-pressure boiler system using a PC/XT computer, a Lab-PC, an SC-2071 board, and a J-type thermocouple. The maximum temperature that can be reached in this example is 300° C. Before taking readings, you must configure the Lab-PC board for the maximum resolution possible. A thermocouple Table shows that the output voltage never exceeds 16 to 17 mV (recall that the exact voltage measured is a function of the SC-2071 board temperature as well as the temperature being measured). Therefore, you should select a ± 5 V input range with a gain of 100 (± 50 mV maximum signal). Set the jumpers on the Lab-PC board for ± 5 V input range. Set Jumper W1 on the SC-2071 board to select the temperature sensor, as shown in Figure 3-4. To connect the thermocouple to channel 1, connect one lead to the CH1 terminal and the other to the AIGND terminal. For this example, do not add any lowpass filters or broken thermocouple detection.

The procedure for this example is as follows:

1. Read the voltage from the temperature sensor. If you are using an NI-DAQ software package, you can use the `AI_Read` and `AI_Scale` functions to do the reading. The temperature sensor voltage is the voltage on channel 0. This voltage is 10 mV/°C, so the gain should be either 1 or 10 for this reading (10 for the best resolution). Multiply the voltage by 100 to get the SC-2071 board temperature in degrees Celsius. For example, if the reading is 0.25 V, the SC-2071 board is at 25° C.
2. Read the voltage on analog input channel 1, using a gain of 100. If you are using an NI-DAQ software package, you can use the `AI_Read` and `AI_Scale` functions to read the channel.
3. Translate the voltage reading into an uncompensated temperature using either a look-up Table or a polynomial such as that described in Formula 3-4. For example, assume that the reading from the thermocouple is 9.39 mV. By applying Formula 3-6 and the coefficients from Table 3-4, you can calculate that the uncompensated temperature is 175° C.
4. Add the cold-junction temperature from step 1 to the uncompensated temperature obtained in step 3. This result is the temperature at the measuring end of the thermocouple. For the example given, the temperature is 175° C + 25° C = 200° C.

The method of temperature calculation used in this example yields only an approximate value. For a discussion on the preferred method of temperature calculation, which uses voltage compensation calculations, see National Instruments Application Note 043, *Measuring Temperature with Thermocouples*.

Sources of Error

When making thermocouple measurements with the SC-2071 board and a Lab/1200 device, the possible sources of error are compensation, linearization, measurement, and thermocouple wire errors.

Compensation error can arise from two sources, inaccuracy of the temperature sensor and temperature differences between the sensor and the screw terminals. The sensor used on the SC-2071 board is specified to be accurate to $\pm 1^\circ\text{C}$. Minimize temperature differences between the sensor and the screw terminals by keeping the SC-2071 board away from drafts, heaters, and warm equipment.

Linearization error is a consequence of the fact that the polynomials are by their very nature approximations of the true thermocouple output. The linearization error is dependent on the degree of polynomial used. Table 3-4 lists the linearization errors for the NBS polynomials.

Measurement error is the result of inaccuracies in the Lab/1200 device. These inaccuracies include gain and offset. If the device is properly calibrated, the offset error should be zeroed out. The only remaining error is a gain error of $\pm 0.08\%$ of full range (see the Lab/1200 device specifications). If the input range is 5 V and the gain is 100, then the gain error contributes $0.0008 \times 100 \text{ mV}$, or $80 \mu\text{V}$ of error. If the Seebeck coefficient of a thermocouple is $32 \mu\text{V}/^\circ\text{C}$, this measurement error adds 2.5°C of uncertainty to the measurement. For best results, use a well-calibrated Lab/1200 device so that offsets can be neglected. Offset error can be eliminated, however, by grounding one channel on the SC-2071 board and measuring it. This value is the offset of the Lab/1200 device, and it can then be subtracted in software from all other readings.

Finally, thermocouple wire error is the result of inconsistencies in the thermocouple manufacturing process. These inconsistencies, or nonhomogeneities, are the result of defects or impurities in the thermocouple wire. The errors vary widely depending on the thermocouple type and even the gauge of wire used, but a value of $\pm 2^\circ\text{C}$ is typical.

For best results, use an average of about 100 readings. When averages are used, typical accuracies are about $\pm 2^\circ\text{C}$.

Thermocouple Measurement Accuracies

Table 3-5 lists the expected thermocouple accuracies in degrees Celsius, subject to the following conditions:

- The Lab/1200 device is correctly calibrated.
- The temperature of the screw terminals equals the temperature of the device (no gradients on the device).

The uncertainties listed apply at either 0°C (Type J, K, E, T) or 600°C (Type S, R). The linearization errors of the NBS polynomials in Table 3-4, measurement error of a calibrated Lab/1200 device, and the $\pm 1^\circ\text{C}$ cold-junction sensor error are all included. Thermocouple wire error is neglected because of dependence on several factors as listed above. Finally, these uncertainties are for the gain listed with a $\pm 5 \text{ V}$ input range.

Table 3-5. Thermocouple Measurement Accuracies

	Type					
Gain	J	K	E	T	S	R
100	$\pm 2.7^{\circ}\text{C}$	$\pm 3.7^{\circ}\text{C}$	$\pm 2.9^{\circ}\text{C}$	$\pm 3.6^{\circ}\text{C}$	$\pm 9.8^{\circ}\text{C}$	$\pm 8.5^{\circ}\text{C}$

Additional Signal Connection Information

For more information about signal connection, refer to Chapter 2 in your Lab/1200 device user manual.

Chapter 4

SC-2072 Board

This chapter describes the SC-2072 board in detail, including function, connection, mounting, and soldering/desoldering.

The SC-2072 board comes in two configurations—the SC-2072 comes without a DC-to-DC converter, whereas the SC-2072D comes with a DC-to-DC converter. Unless the text denotes otherwise, all references to the SC-2072 board apply to both configurations.

The SC-2072 is a general-purpose termination breadboard that makes it easy to connect to all NB Series, MC Series, PC Series, AT Series, Lab/1200 Series, and the PC-OPDIO-16 DAQ, digital I/O, and timing devices (except for the NB-A2000 and the EISA-A2000), and some DAQCards; add analog input signal conditioning, such as filters and dividers; and build external, custom timing, analog, and digital circuits.

The SC-2072 board is used with the National Instruments DAQ devices for the Macintosh, IBM PS/2 Micro Channel, and PC/XT/AT and compatible computers.

The SC-2072 board has screw terminals for all 50 signals present on the I/O cable. These terminals can be used for easy connection to the analog, digital, timing, and trigger signals from the expansion board. In addition, the SC-2072 board has one set of 12 terminals that can be used for connection of 12 external signals.

For digital power connections, one set of three terminals can be used to connect digital power and ground inputs to an external power supply. On the base model of the board, the SC-2072, a second set of three terminals connects positive, negative, and common power inputs for powering onboard analog circuitry. The second model of the board, the SC-2072D, comes equipped with a DC-to-DC converter that can be used to power analog circuitry (see *Power Connections* later in this chapter). A breadboard area of 2.4 by 4.6 in. is also included.

The SC-2072 can be used in conjunction with the other signal conditioning accessories, including the SC-206X Series boards and SSR Series boards. An SC-205X Series cable adapter board must be used for connection of multiple signal conditioning accessories.

Figure 4-1 shows the parts locator diagram for the SC-2072 board. Figure 4-2 shows the parts locator diagram for the SC-2072D board.

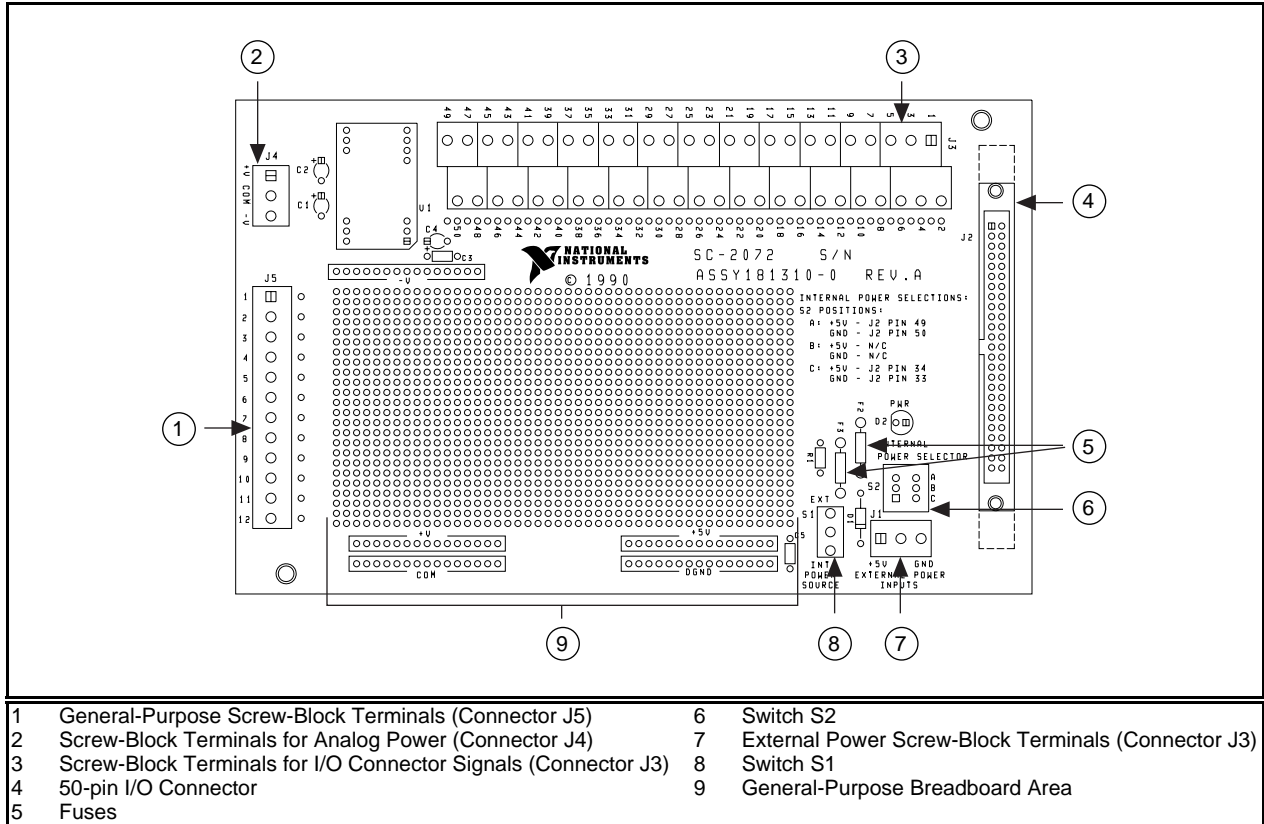

Figure 4-1. SC-2072 Board Parts Locator Diagram

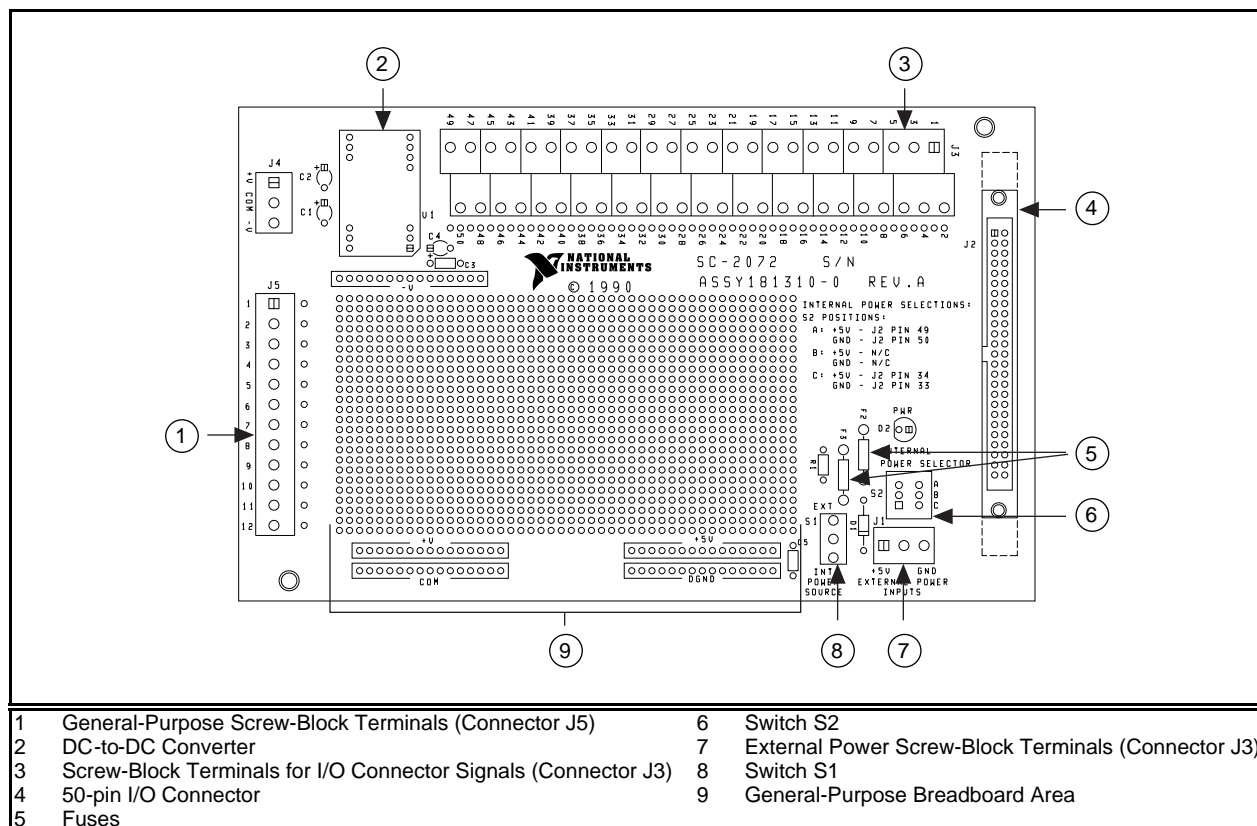

Figure 4-2. SC-2072D Board Parts Locator Diagram

Signal Connections

The SC-2072 board is equipped with one 50-pin cable connector, one 50-position screw-terminal block, and one 12-position screw-terminal block. Each of the 50 signals located on the cable connector (J2) is tied directly to the correspondingly numbered terminal on screw-terminal block J3. External I/O lines can be tied directly to the I/O cable by connecting the lines to screw-terminal block J3. In addition, a 12-position screw-terminal block (J5) can be used to connect external signals to the breadboard area without connecting them to the I/O cable simultaneously. A line of solder holes adjacent to both J3 and J5 can be used to connect the screw terminals to the breadboard area. If you rotate the SC-2072 board so that the label J3 is in the top left corner, the connection holes are to the right of J3. The even numbers to the right of J3 correspond to the screw terminals themselves, not to the connection holes. However, these numbers can be used to determine the line number. The holes just slightly up from the numbers correspond to that numbered signal; be careful here as the holes are numbered 2, 1, 4, 3, 6, 5, ..., 50, 49. If you rotate the SC-2072 board so that the label J5 is closest to the top left corner, the connection holes are to the right of J5. In this case, the hole directly to the right of a terminal is connected to that terminal.

For more information on the signals present on the I/O cable connector, consult your expansion or other signal conditioning board manual.

Power Connections

Because the SC-2072 board is a general-purpose board, it has a more flexible power connection scheme than the SC-2070 and SC-2071 boards. In addition, the SC-2072 board comes in two different configurations based on your external power supply needs.

Both configurations of the SC-2072 come with two power-selection switches and a three-position screw-terminal block, all of which are dedicated to selecting the digital power supply and its ground. Switch S1 selects either the internal or the external digital power supply. If you set the switch to the external supply (labeled EXT), the terminal block is connected to the local power and ground lines. If you set the switch to the internal supply (labeled INT), the switch S2 is responsible for selecting the power inputs from the I/O cable. Switch S2 is a three-position switch that configures the SC-2072 to connect to pins 49 (+5 V) and 50 (DGND) in position A, to no I/O pins in position B, and to pins 33 (DGND) and 34 (+5 V) in position C. Table 4-1 shows the setting to be used with each of the National Instruments DAQ devices.

Table 4-1. Switch S2 Settings for National Instruments DAQ Devices

Device	S2 Setting
AT-DIO-32F	B
AT-MIO-16	C
AT-MIO-16D	C
AT-MIO-16F-5	C
AT-MIO-16X	C
AT-MIO-64F-5	C
Lab-PC	A
Lab-PC+	A
DAQCard-1200	A
DAQPad-1200	A
PCI-1200	A
PC-DIO-24	A
PC-DIO-96	A
PC-LPM-16	A
PC-TIO-10	C
MC-DIO-24	A
MC-DIO-32F	B
MC-MIO-16	C
Lab-LC	A
Lab-NB	A
NB-DIO-24	A
NB-DIO-32F	B
NB-MIO-16	C
NB-MIO-16X	C
DAQCard-700	A
DAQCard-DIO-24	A
PC-OPDIO-16	A

Warning: *If the DAQ device does not use pins 33/34 or pins 49/50 for power connections or if the external power supply is used, set switch S2 to position B. Failure to set switch S2 to position B under these conditions could result in damage to your external power supply, the SC-2072 and its breadboarded circuitry, the expansion board connected to the SC-2072, and/or your computer. National Instruments is NOT liable for damage resulting from such connections.*

The base model of the SC-2072, the SC-2072, comes with an additional three-position screw-terminal block that can be used to supply positive, negative, and common (analog ground) voltage signals to the board. If you have this version of the board and want to install filter capacitors for the supplies, you can install them in positions C1 and C2 (next to J4). If you choose to install capacitors in these holes, the capacitors should be high-quality tantalum capacitors that are rated at least several volts over your power supply outputs. For example, if you connect ± 12 V to the board, you need capacitors rated for 16 V (the next rating above 12 V). Install the positive terminal of the capacitor in the hole adjacent to the plus symbol.

The second model of the SC-2072, the SC-2072D, comes with a DC-to-DC converter and accompanying filter capacitors. On this version of the board, no screw-terminal block is installed in position J4. Instead of using an external power source to supply power for your analog circuitry, the DC-to-DC converter converts the +5 V digital power supply into +15 V and -15 V, therefore supplying a convenient power source for your analog circuitry.

Warning: *If you accidentally short the terminals at J4 or otherwise connect the outputs from the DC-to-DC converter together, damage to the converter and your breadboarded circuitry can occur. Because of the power supply fuses F2 and F3, damage to your external digital power supply, your expansion board, or your computer is unlikely. Regardless of how such connections might be incurred, National Instruments is NOT liable for damage resulting from such connections.*

Fuses and Power LED

The +5 V line is protected by a 1 A fuse, regardless of the S1 switch setting. If you are using an external digital supply, the digital ground line is also protected by a 1 A fuse. In addition, a diode is reverse-biased across the external +5 V and digital ground inputs of J1.

Warning: *If you connect your external digital power supply backwards, the diode D1 conducts, therefore limiting the voltage applied to the inputs to about 0.7 V. In this case, your power supply can go into thermal shutdown or blow a fuse, but your breadboarded circuitry, your expansion board, and your computer should not be harmed. National Instruments is NOT liable for damage resulting from such connections.*

If you are using the digital supply and the red power LED does not light when the expansion board or external power supply is powered on, check both the SC-2072 fuses and the output fuse (if any) on the expansion board or the power supply. More information on connecting power is given in Chapter 5, *Installation and Connections*.

Board-to-Board Cabling

The SC-2072 board connects directly to all NB Series, MC Series, PC Series, AT Series, Lab/1200 Series, and the PC-OPDIO-96 DAQ, digital I/O, and timing devices (except for the NB-A2000 and the EISA-A2000), and some DAQCards. The various expansion devices connect to the SC-2072 board as shown in Figure 4-3.

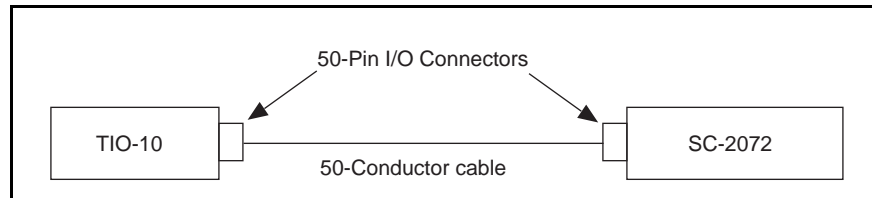

Figure 4-3. Direct Connection between a TIO-10 Board and the SC-2072 Board

If you want any signal conditioning of the digital I/O ports with the National Instruments SC-206X Series boards, you can use an SC-205X Series cable adapter board. The SC-2050 can be used with any MIO-16. The SC-2051 can be used with any DIO-24 or with a PC-DIO-96 that is equipped with a PC-DIO-96 to DIO-24 converter. The SC-2052 can be used with any DIO-32F. The SC-2053 can be used with either the Lab-NB, the Lab-LC, the Lab-PC, or the Lab-PC+. Figure 4-4 shows a connection using the SC-2051 cable adapter board.

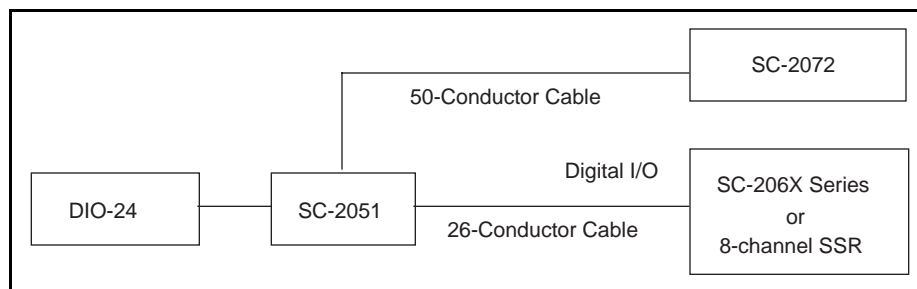

Figure 4-4. Connection between a DIO-24 Board and the SC-2072 Board via the SC-2051 Board

Warning: *Do not connect the SC-2072 board to any board other than a National Instruments DAQ device or a National Instruments SC-205X Series cable adapter board. The SC-2072 board is not compatible with any other DAQ devices or cable adapter boards. Attempts to use the SC-2072 board with products for which it is not intended can result in damage to the SC-2072 board, the DAQ device, or the host computer. National Instruments is NOT liable for damages resulting from these connections.*

The SC-2072 board uses a 50-pin ribbon cable connector to connect to the 50-pin I/O connector on either a DAQ device or an SC-205X Series cable adapter board. If the SC-205X Series cable adapter board is being used, the SC-2050 connects to the DAQ device with a 50-conductor ribbon cable. The SC-2072 board then connects to the other 50-pin I/O connector on the SC-205X Series board. For more information, see Chapter 5, *Installation and Connections*.

Mounting

The SC-2072 board is equipped with metal standoffs so the board can be placed on a workbench near the host computer. You can use an optional rack-mount chassis, which can be fitted with a flat, acrylic plastic cover. For more information, see Chapter 5, *Installation and Connections*.

Soldering and Desoldering on the SC-2072 Board

Use a low-wattage soldering iron (20 to 30 W) when soldering to the board. To desolder on the SC-2072, vacuum-type tools work best. Use care when desoldering to avoid damaging component pads. Only use rosin-core electronic-grade solder. Acid-core solder damages the printed circuit board and components.

Chapter 5

Installation and Connections

This chapter explains how to install and make connections to the SC-207X Series boards.

Hardware Installation

Most of the sections that follow apply to all of the SC-207X Series boards. However, several topics are more board-specific than others. Unless a given topic is delineated by board, the topic applies to all SC-207X Series boards.

Hardware Installation for the SC-2070 and the SC-2071

The following are general instructions for installing your SC-2070 or SC-2071 board in your computer DAQ system. Consult the user manual or technical reference manual of your computer for specific instructions and warnings.

Caution: *Turn the host computer off before making any connections.*

1. Determine what signal conditioning is desired for the analog inputs and install the necessary components into the open component positions. If no signal conditioning is needed on an input, then the factory-installed jumpers (on the SC-2070) or jumper (on the SC-2071) must be in place.
2. Check that jumpers W1 and W2 are set correctly for the current application.
3. Mount the SC-207X Series board into a 19-in. rack (optional).
4. Connect the SC-207X Series board to the DAQ device using a 50-pin ribbon cable. (If an SC-205X Series board is used with the SC-207X Series boards, install and mount the SC-205X Series board as instructed in the *SC-205X Series User Manual*, then connect the SC-207X Series board to the SC-205X Series board using the 50-pin cable and connect the SC-205X Series board to the DAQ device.)
5. Connect field signals to the SC-207X Series board at the screw terminals.
6. Attach the appropriate cover to the rack mount (optional).
7. Turn the computer on.
8. When finished, turn off any powered external signals to the SC-207X Series board before turning off the computer.

Warning: *The SC-207X Series boards have not been designed for use with high voltage. Although the open component positions are configured so that voltage dividers can be installed to reduce a high input voltage to within the DAQ device's ± 10 V input range, the maximum safe input voltage at any point on the SC-207X Series boards is 42 V peak. Input voltages larger than 42 V, even if attenuated by a voltage divider on the SC-207X Series board, can result in damage to the SC-207X Series board, the DAQ device, or the host computer. High voltage can also cause an electric shock hazard to you. National Instruments is NOT liable for damages or injuries resulting from these connections.*

Hardware Installation for the SC-2072

The following are general instructions for installing your SC-2072 board in your computer DAQ system. Consult your computer's user manual or technical reference manual for specific instructions and warnings.

Caution: *Turn the host computer off before making any connections.*

1. Mount the SC-2072 board into a 19-in. rack (optional).
2. Connect the SC-2072 board to the DAQ device using a 50-pin ribbon cable. (If an SC-205X Series board is used with the SC-2072 board, install and mount the SC-205X Series board as instructed in the *SC-205X Series User Manual*, then connect the SC-2072 board to the SC-205X Series board using the 50-pin cable and connect the SC-205X Series board to the DAQ device.)
3. Connect field signals to the SC-2072 board at the screw terminals.
4. Attach the appropriate cover to the rack mount (optional).
5. Turn the computer on.
6. When finished, turn off any powered external signals to the SC-2072 board before turning off the computer.

Warning: *The SC-207X Series boards have not been designed for use with high voltage. Input voltages larger than 42 V can result in damage to the SC-2072, the DAQ device, or the host computer. High voltage can also cause an electric shock hazard to you. National Instruments is NOT liable for damages or injuries resulting from these connections.*

Installing the SC-205X Series Cable Adapter Boards

Consult the *SC-205X Series User Manual* for instructions on installing your SC-205X Series board if any of these boards are being used.

Installing the BNC-2081 Analog Breakout Board

Consult your *BNC-208X Series User Manual* for instructions on installing your BNC-2081 board if this board is being used.

Rack Mounting

Your SC-207X Series board can be installed on two-thirds of a 19-in. rack chassis. You can mount one SC-207X Series board alongside an SC-205X Series cable adapter board or an SC-206X Series digital signal conditioning board. Mount your SC-207X Series board on the left or right side of the 19-in. rack mount. The SC-207X Series board occupies two of the three mounting positions shown in Figure 5-1.

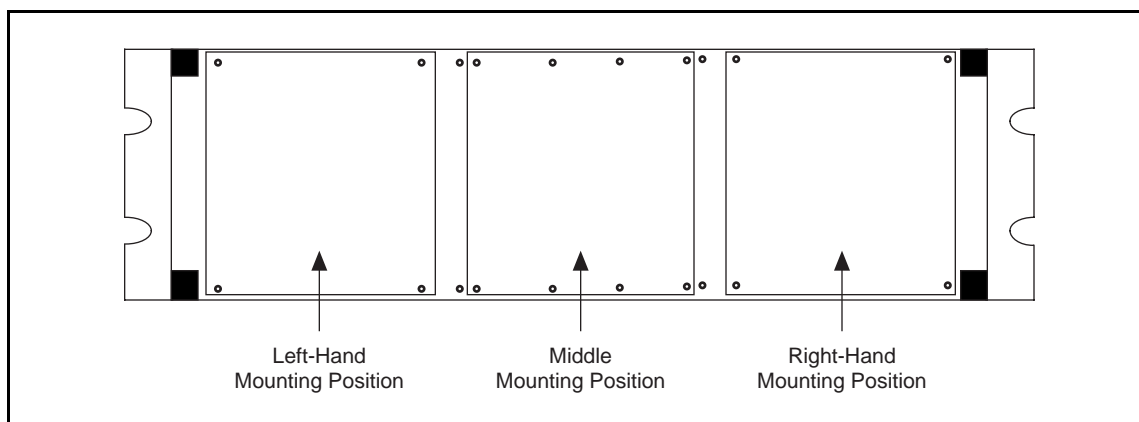

Figure 5-1. Mounting Locations for SC-207X Series Boards

Mount the SC-207X Series board in the chassis by removing the screws on the bottoms of the four standoffs attached to the board and using the same screws to attach the board to the mounting rack (see Figure 5-2).

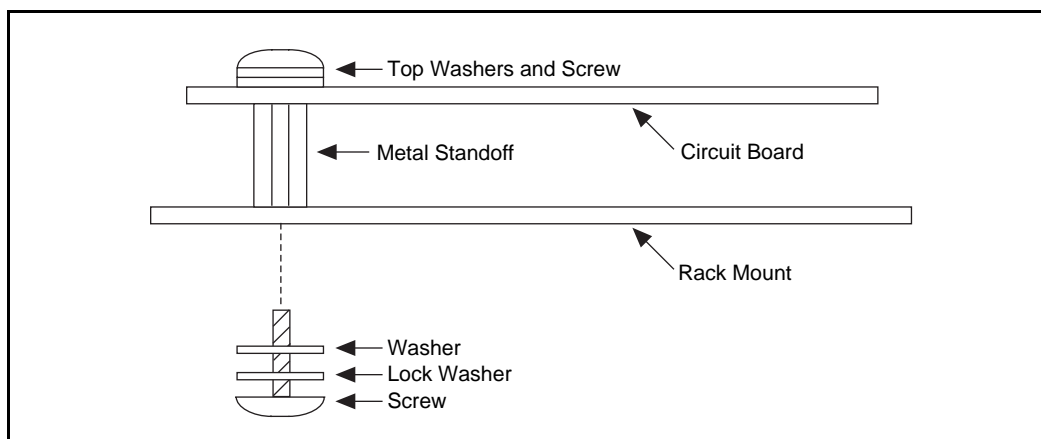

Figure 5-2. Attaching a Mountable Board to the Chassis

Be sure to include the washers around the screws when attaching your board to the rack mount (see Figure 5-2).

Notice that jumper W2 can connect the digital ground for the SC-2070 and SC-2071 boards to the metal standoffs attached to the board. Rack mounting does not automatically ground the board to the metal chassis unless jumper W2 is set.

If two SC-207X Series boards connected to different DAQ devices need to be stacked, double-height mounting within one rack-mount chassis is possible. Because only one SC-207X Series board can be used with each DAQ device, this situation occurs only if two or more DAQ devices are being used. You need a hardware kit for double-height mounting (see *Optional Equipment* in Chapter 1) consisting of two brackets that are installed in the rack mount. A second row of boards can be mounted on these brackets in the same way the first row is mounted. Figure 5-3 illustrates double-height mounting.

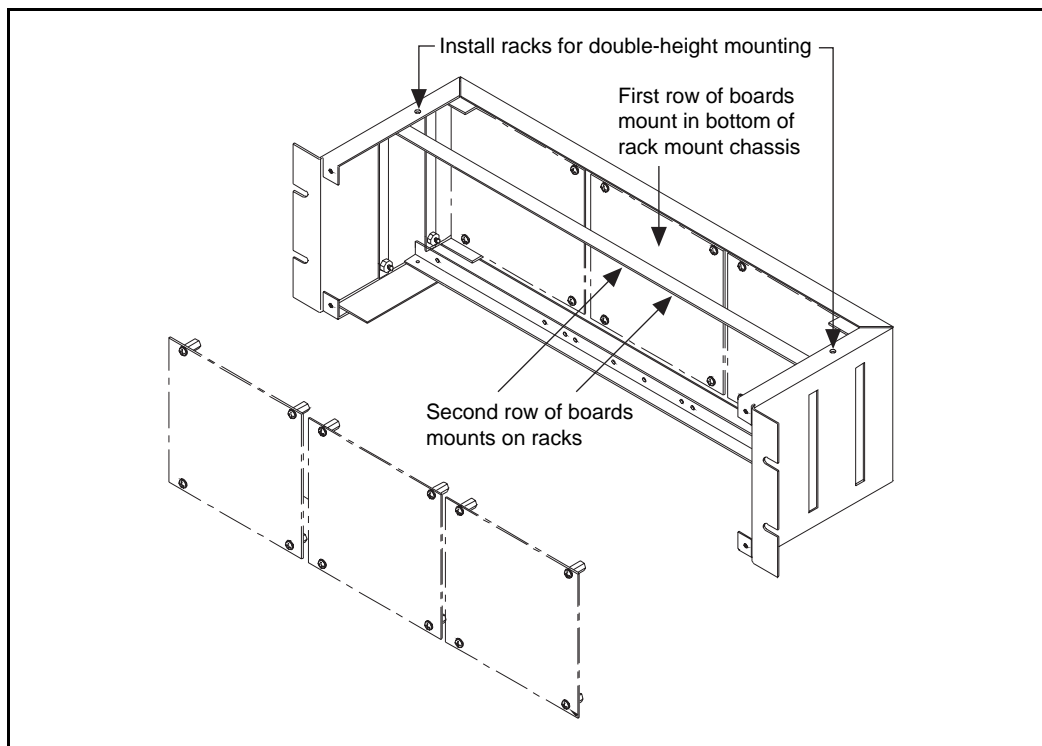

Figure 5-3. Double-Height Mounting

External Power Connection (If Necessary)

Because your SC-207X Series board draws very little current from the computer power supply, an external +5 VDC supply is unnecessary in most cases. If several high-current SC-206X Series digital signal conditioning boards (such as the SC-2062 board) are being used on the same DAQ device as the SC-207X Series board, some of these boards need to be powered by an external +5 VDC supply. Because the SC-206X Series boards draw much more current than the SC-207X Series, the SC-206X Series boards should be powered from the external supply, and the SC-207X Series board should be run from the host computer power supply. However, your SC-207X Series board can be powered from an external +5 VDC power supply.

An external supply can be necessary in the following situations:

- A particularly high-current circuit has been constructed on the general-purpose breadboarding area.
- The power requirements for equipment connected to the computer's power supply exceed the rating for that supply.

To connect the external power supply (the power supply must be turned off) to the SC-2070 or the SC-2071, first remove fuse F1. Then connect the wires from the +5 VDC and the supply ground lines to the screw terminals labeled +5 V and DGND on the board.

To connect the external digital power supply (the power supply must be turned off) to the SC-2072, connect the wires from the +5 VDC and the ground lines of the supply to the screw terminals labeled +5 V and GND on the board. To connect the external analog power supply (the power supply must be turned off) to the SC-2072, connect the wires from the positive, ground, and negative supply outputs to the screw terminals labeled +V, COM, and -V, respectively.

Table 5-1 shows the amount of power that each DAQ device can supply to external accessories. Use this table to determine if any accessory boards need to be powered by an external supply.

Table 5-1. Amount of Power Supplied by DAQ Devices

Board	Allotted Power by Slot	Power Used by Board	Power from Board Available for Accessories
AT-DIO-32F	Not Specified ¹	1.28 A	0 A ³
AT-MIO-16	Not Specified ¹	1.5 A	1 A ²
AT-MIO-16D	Not Specified ¹	1.75 A	1 A ²
AT-MIO-16F-5	Not Specified ¹	1.7 A	1 A ²
AT-MIO-16X	Not Specified ¹	2.0 A	1 A ²
AT-MIO-64F-5	Not Specified ¹	2.0 A	1 A ²
Lab-PC	Not Specified ¹	0.6 A	1 A ²
Lab-PC+	Not Specified ¹	0.6 A	1 A ²
DAQCard-1200	1.0 A	0.15 A	0.85 A
DAQPad-1200	—	—	0.4 A
PCI-1200	1.5 A	0.43 A	1 A ²
PC-DIO-24	Not Specified ¹	0.16 A	1 A ²
PC-DIO-96	Not Specified ¹	0.45 A	1 A ²
PC-LPM-16	Not Specified ¹	0.13 A	1 A ²
PC-TIO-10	Not Specified ¹	0.6 A	1 A ²
MC-DIO-24	1.6 A	0.8 A	0.8 A
MC-DIO-32F	1.6 A	1.4 A	0 A ³
MC-MIO-16	1.6 A	1.4 A	0.2 A
Lab-LC	0.8 A	0.25 A	0.5 A
Lab-NB	2.0 A	0.8 A	1 A ²
NB-DIO-24	2.0 A	0.8 A	1 A ²
NB-DIO-32F	2.0 A	1.6 A	0 A ³
NB-MIO-16	2.0 A	1.5 A	0.5 A
NB-MIO-16X	2.0 A	1.4 A	0.25 A ²
DAQCard-700	1.0 A	0.12 A	0.88 A
DAQCard-DIO-24	1.0 A	0.1 A	0.9 A
PC-OPDIO-16	Not Specified ¹	0.5 A	1.0 A ²
¹ The allocated power by slot is not specified on the XT and AT bus and depends on the power supply capacity and the power used by other boards installed in your system. ² These limitations are caused by a series fuse on the +5 V out on these boards, rather than the remaining power per slot. ³ The DIO-32F does not have a +5 V digital supply output. All SSR Series modules require an external power supply when used with the DIO-32F.			

SC-207X Series Board Connection

Figure 5-4 illustrates the connections from the SC-2070 or SC-2071 boards directly to DAQ devices via a 50-conductor cable and to DAQ devices via the SC-205X Series boards. Because the SC-2072 board is somewhat more flexible, no connection scheme is outlined. However, the SC-2072 connection parallels that of the SC-2070 and SC-2071.

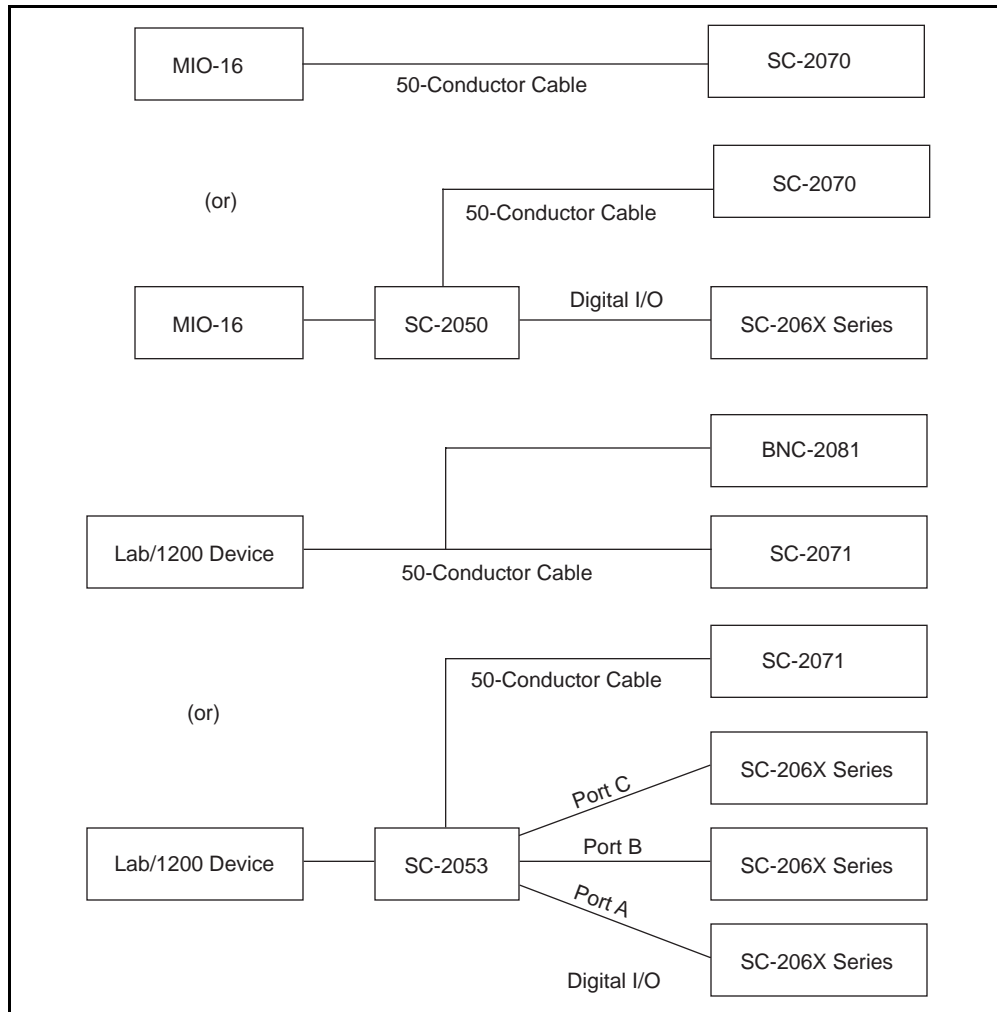

Figure 5-4. Connections Between DAQ Devices and SC-205X Series Boards and Between SC-205X Series Boards and SC-2070 and SC-2071 Boards

A 50-pin ribbon cable connects your SC-207X Series board to either an SC-205X Series board or directly to the DAQ device. Remember to turn the host computer off before making any connections. One end of the ribbon cable connects to the SC-207X Series board at connector J1 (SC-2070 and SC-2071) or J2 (SC-2072). The other end connects either to the DAQ device or to one of the two 50-pin headers on the SC-205X Series board you installed for use with the DAQ device.

Signal Connections

Ribbon Cable Connectors

The pinout for the 50-pin ribbon cable connector on the SC-2070 board is exactly the same as the 50-pin connector on the MIO-16 board. The pinout for the 50-pin ribbon cable connector on the SC-2071 board is exactly the same as the 50-pin connector on the Lab/1200 device. The pinout for the 50-pin ribbon cable connector on the SC-2072 board is exactly the same as the 50-pin connector on the host DAQ device. For more information on these connectors, refer to your DAQ device’s user manual. Table 5-2 lists SC-207X Series compatibility with the SC-205X Series boards.

Table 5-2. SC-205X Series Board Connectors Compatible with the SC-207X Series Boards

Connectors	Connections	Description
J1, J2	50-pin male connectors SC-2050 (for MIO-16 boards)	One of these must attach to the host MIO-16 board. The other connection can attach to the SC-2070 board.
J1, J2	50-pin male connectors SC-2053 (for Lab/1200 boards)	One of these must attach to the host Lab/1200 board. The other connection can attach to the SC-2071 board.
J1, J2	50-pin male connectors SC-205X Series boards	One of these must attach to the host DAQ device. The other connection can attach to the SC-2072 board.
<p>Warning: <i>Do not attempt to connect an SC-207X Series board to any connector for which it is not designed. Such connections can result in damage to any or all of the boards connected to the SC-207X Series board, to the host computer, and to the SC-207X Series boards themselves. National Instruments is NOT liable for any damages resulting from such misuse.</i></p>		

Screw Terminal Connections for the SC-2070 and the SC-2071

The SC-2070 and SC-2071 boards supply analog input to the host computer (via the DAQ device) via the screw terminals along one edge of the board. The remaining signals from the DAQ device are available at screw terminals on the other side of the board. Additionally, eight undedicated screw terminals are located adjacent to the general-purpose breadboarding area. Guidelines for connections to the analog input terminals are given in Chapters 2 and 3.

Warning: *Connections, including power signals to ground and vice versa, that exceed any of the maximum input or output voltage ratings on the SC-207X Series boards can result in damage to any or all of the boards connected to the SC-207X Series boards, to the host computer, and to the SC-207X Series boards. Overvoltage conditions also can present a shock hazard to you. National Instruments is NOT liable for any damages or injuries resulting from incorrect signal connections.*

Screw Terminal Connections for the SC-2072

The SC-2072 board connects all fifty I/O signals from the DAQ device to screw terminals on board. Additionally, twelve undedicated screw terminals are located adjacent to the general-purpose breadboarding area.

Warning: *Connections, including power signals to ground and vice versa, that exceed any of the maximum input or output voltage ratings on the SC-207X Series boards can result in damage to any or all of the boards connected to the SC-207X Series boards, to the host computer, and to the SC-207X Series boards. Overvoltage conditions also can present a shock hazard to you. National Instruments is NOT liable for any damages or injuries resulting from incorrect signal connections.*

Rack-Mount Chassis Cover Attachment

The optional 19-in. rack-mount accessory includes a flat, acrylic plastic cover that can be installed using the four screws included in the kit. Covering the top and bottom is required for safety reasons if an SC-206X Series board in the same enclosure is to be used in high-voltage situations (see the following warning). Remember that voltages above the 42 V peak cannot be applied to the SC-207X Series inputs.

Warning: *The SC-206X Series boards must be completely enclosed if any onboard voltages or any voltages connected to the relays can exceed 42 V.*

Appendix A

Specifications

This appendix contains specifications for the SC-207X boards. These specifications are typical at 25° C unless otherwise noted.

Analog Input

Number of channels	Eight differential, 16 single-ended
Field connections	36 labeled or numbered screw terminals with direct connection to all analog and digital signals on multifunction DAQ board
Cold-junction temperature sensor	
Accuracy	±0.5° C from 0° to 110° C
Output	10 mV/°C, jumper selected on channel 0
Compensation	Performed by software on host computer
Conditioning capability	Seven open component positions per channel that include connections from each input to ground, +5 V, each other, and series connections to the inputs of the DAQ boards

Breadboarding Area

SC-2070 and SC-2071	10.2 by 3.8 cm (4.0 by 1.5 in.)
SC-2072	10.9 by 7.6 cm (4.3 by 3.0 in.)
Feedthrough size	0.09 cm (0.0351 in.) diameter on 0.25 cm (0.1 in.) center spacing
Features	Eight undedicated screw terminal connections 40 feedthroughs connected to +5 VDC 40 feedthroughs connected to ground
Voltage available.....	+5 V and DGND, on two bus strips

Power Requirement (from DAQ board)

+5 VDC	5 mA (typ with no user circuitry connected)
--------------	---

Note: *The power specifications pertain to the power supply of the host computer when using internal power or to the external supply connected at the +5 V screw terminal when using external power. The maximum power consumption of the SC-2070 board is a function of the signal conditioning components installed and any circuits constructed on the general-purpose breadboard area. If the board is being powered from the host computer, the maximum +5 V current draw is fuse-limited to 800 mA.*

Physical

Dimensions (including standoffs)20.1 by 12.5 by 4.6 cm (7.9 by 4.9 by 1.8 in.)
Signal connections54 screw terminals
I/O connector.....One 50-pin male ribbon cable connector

Environment

Operating temperature0° to 70° C
Storage temperature-55° to 110° C
Relative humidity5% to 90%, noncondensing

Appendix B

Customer Communication

For your convenience, this appendix contains forms to help you gather the information necessary to help us solve technical problems you might have as well as a form you can use to comment on the product documentation. Filling out a copy of the *Technical Support Form* before contacting National Instruments helps us help you better and faster.

National Instruments provides comprehensive technical assistance around the world. In the U.S. and Canada, applications engineers are available Monday through Friday from 8:00 a.m. to 6:00 p.m. (central time). In other countries, contact the nearest branch office. You may fax questions to us at any time.

Corporate Headquarters

(512) 795-8248

Technical support fax: (800) 328-2203
(512) 794-5678

Branch Offices	Phone Number	Fax Number
Australia	03 9 879 9422	03 9 879 9179
Austria	0662 45 79 90 0	0662 45 79 90 19
Belgium	02 757 00 20	02 757 03 11
Canada (Ontario)	519 622 9310	519 622 9311
Canada (Quebec)	514 694 8521	514 694 4399
Denmark	45 76 26 00	45 76 71 11
Finland	90 527 2321	90 502 2930
France	1 48 14 24 24	1 48 14 24 14
Germany	089 741 31 30	089 714 60 35
Hong Kong	2645 3186	2686 8505
Italy	02 48301892	02 48301915
Japan	03 5472 2970	03 5472 2977
Korea	02 596 7456	02 596 7455
Mexico	95 800 010 0793	5 520 3282
Netherlands	0348 433466	0348 430673
Norway	32 84 84 00	32 84 86 00
Singapore	2265886	2265887
Spain	91 640 0085	91 640 0533
Sweden	08 730 49 70	08 730 43 70
Switzerland	056 200 51 51	056 200 51 55
Taiwan	02 377 1200	02 737 4644
U.K.	01635 523545	01635 523154

Technical Support Form

Photocopy this form and update it each time you make changes to your software or hardware, and use the completed copy of this form as a reference for your current configuration. Completing this form accurately before contacting National Instruments for technical support helps our applications engineers answer your questions more efficiently.

If you are using any National Instruments hardware or software products related to this problem, include the configuration forms from their user manuals. Include additional pages if necessary.

Name _____

Company _____

Address _____

Fax (____) _____ Phone (____) _____

Computer brand _____ Model _____ Processor _____

Operating system _____

Speed _____MHz RAM _____MB Display adapter _____

Mouse _____yes _____no Other adapters installed _____

Hard disk capacity _____MB Brand _____

Instruments used _____

National Instruments hardware product model _____ Revision _____

Configuration _____

National Instruments software product _____ Version _____

Configuration _____

The problem is _____

List any error messages _____

The following steps will reproduce the problem _____

Documentation Comment Form

National Instruments encourages you to comment on the documentation supplied with our products. This information helps us provide quality products to meet your needs.

Title: **SC-207X Series User Manual**

Edition Date: **November 1995**

Part Number: **371173A-01**

Please comment on the completeness, clarity, and organization of the manual.

If you find errors in the manual, please record the page numbers and describe the errors.

Thank you for your help.

Name _____

Title _____

Company _____

Address _____

Phone (_____) _____

Mail to: Technical Publications
National Instruments Corporation
6504 Bridge Point Parkway,
Austin, TX 78730-5039

Fax to: Technical Publications
National Instruments Corporation
(512) 794-5678

Glossary

Prefix	Meaning	Value
μ-	micro-	10 ⁻⁶
m-	milli-	10 ⁻³
k-	kilo-	10 ³
M-	mega-	10 ⁶

°	degrees
Ω	ohms
%	percent
π	pi
A	amperes
AC	alternating current
ADC	analog to digital converter
AIGND	analog input ground
C	Celsius
CJC	cold-junction compensation
dB	decibels
DC	direct current
DGND	digital ground
DIFF	differential (input mode)
F	farads
f _c	cutoff frequency
GND	ground
Hz	hertz
in.	inches
I/O	input/output
K	kilobytes
LED	light-emitting diode
LSB	least significant bit
m	meters
MB	megabytes of memory
NBS	National Bureau of Standards
NRSE	nonreferenced single-ended (input mode)
PS/2	Personal System/2
RSE	referenced single-ended (input mode)
S/N	signal to noise
SSR	solid-state relay
V	volts
VDC	volts direct current
W	watts

Index

A

- accuracy of thermocouple measurements
 - SC-2070 board, 2-25
 - SC-2071 board, 3-20 to 3-21
- analog input
 - SC-2070 board, 2-2 to 2-3
 - component positions in each channel (table), 2-3
 - onboard equivalent circuit (figure), 2-3
 - SC-2071 board, 3-2 to 3-3
 - component positions in each channel (table), 3-3
 - onboard equivalent circuit (figure), 3-3
 - specifications, A-1
- analog input channel configurations, SC-2070 board, 2-7. *See also* signal source connections.
- applications. *See* specific SC-207X board.
- attenuators, building
 - SC-2070 board, 2-15 to 2-16
 - example, 2-16
 - illustration, 2-16
 - input voltages greater than 42 V (warning), 2-15
 - three-resistor circuit (formula), 2-15
 - SC-2071 board, 3-12 to 3-14
 - example, 3-14
 - illustration, 3-13
 - input voltages greater than 42 V (warning), 3-12
 - two-resistor circuit (formula), 3-13

B

- BNC-2081 Analog Breakout Board, installing, 5-3
- board-to-board cabling
 - SC-2070 board, 2-5 to 2-6
 - SC-2071 board, 3-5 to 3-7
 - SC-2072 board, 4-6

- breadboarding area specifications, A-1
- broken thermocouple detection
 - SC-2070 board, 2-18 to 2-19
 - thermocouple circuit with open thermocouple detect (figure), 2-19
 - SC-2071 board, 3-15 to 3-16
 - thermocouple circuit with open thermocouple detect (figure), 3-16

C

- cabling. *See* board-to-board cabling.
- channel configurations, SC-2070 board, 2-7. *See also* signal source connections.
 - differential (DIFF) input, 2-7
 - nonreferenced single-ended (NRSE) input, 2-7
 - referenced single-ended input (RSE), 2-7
- cold junction, 2-17, 3-14
- cold junction compensation (CJC)
 - definition, 2-17, 3-14
 - SC-2070 board, 2-17
 - SC-2071 board, 3-15
- cold junction temperature sensor
 - specifications, A-1
- customer communication, *xiii*, B-1

D

- DAQ devices
 - connection to SC-207X Series boards, 1-2
 - illustrations, 1-3, 5-7
 - connections between DAQ devices and SC-205X Series boards (figure), 5-7
 - power requirement specifications, A-1
 - supported by SC-207X Series boards (table), 1-2
- differential (DIFF) input mode, 2-7
- differential inputs
 - ground-referenced signal sources, 2-9

- nonreferenced or floating signal sources, 2-7 to 2-8
 - bias return resistor for DC-coupled floating source on channel 1 (figure), 2-8
- differential thermocouple measurements, SC-2070 board, 2-22
 - example, 2-22 to 2-23
- digital and timing signals
 - SC-2070 board, 2-4 to 2-5
 - SC-2071 board, 3-5
- documentation
 - conventions used in manual, *xii*
 - organization of manual, *xi*
 - related documentation, *xii-xiii*

E

- environment specifications, A-2
- equipment, optional, 1-4
- error sources for thermocouple measurements
 - SC-2070 board, 2-24
 - SC-2071 board, 3-19 to 3-20

F

- fax technical support, B-1
- floating signal sources. *See also* nonreferenced or floating signal sources.
 - connecting, SC-2071 board, 3-8
- fuses
 - SC-2070 board, 2-4
 - SC-2071 board, 3-4
 - SC-2072 board, 4-5

G

- gain and input ranges
 - thermocouple measurement
 - SC-2070 board, 2-19
 - SC-2071 board, 3-16
 - thermocouple voltage output extremes
 - SC-2070 board (table), 2-20
 - SC-2071 board (table), 3-17

- getting started with SC-207X Series boards, 1-4
- ground-referenced signal sources
 - channel configuration, 2-7
 - connecting
 - SC-2070 board, 2-9
 - differential inputs, 2-9
 - single-ended inputs, 2-9
 - SC-2071 board, 3-8

H

- hardware installation. *See* installation.
- highpass filters, building
 - SC-2070 board, 2-13 to 2-14
 - highpass filter on differential channel 1 (figure), 2-14
 - normalized frequency response (figure), 2-13
 - poor common-mode rejection characteristics (note), 2-14
 - SC-2071 board, 3-10 to 3-12
 - highpass filter on channel 1 (figure), 3-12
 - normalized frequency response (figure), 3-11

I

- input ranges. *See* gain and input ranges.
- installation
 - BNC-2081 Analog Breakout Board, 5- 3
 - external power connection, 5- 4 to 5- 5
 - amount of power supplied by DAQ devices (table), 5- 6
 - mounting
 - rack mounting, 5- 3 to 5- 4
 - attaching mountable board to chassis (figure), 5- 3
 - double-height mounting (figure), 5- 4
 - locations for SC- 207X boards (figure), 5- 3
 - SC- 2070 board, 2- 6
 - SC- 2071 board, 3- 7
 - SC- 2072 board, 4- 7

- SC-205X Series cable adapter boards, 5-2
- SC-207X Series board connection, 5-7
- SC-2070 and SC-2071 boards, 5-1 to 5-2
- SC-2072 board, 5-2
- signal connections, 5-8 to 5-9
 - rack-mount chassis cover attachment, 5-9
 - ribbon cable connectors, 5-8
 - SC-205X Series board connectors compatible with SC-207X boards (table), 5-8
 - screw terminal connections
 - SC-2070 and SC-2071, 5-8
 - SC-2072, 5-9

J

- jumpers and switches
 - SC-2072 board
 - setting switch S2 to position B (warning), 4-4
 - switch S2 settings for National Instruments DAQ devices (table), 4-4
 - W1 jumper
 - SC-2070 temperature sensor (figure), 2-4
 - SC-2071 temperature sensor (figure), 3-4
 - W2 jumper
 - SC-2070 shield ground (figure), 2-4
 - SC-2071 shield ground (figure), 3-4

L

- linearizing data for thermocouple output voltage
 - National Bureau of Standards (NBS) polynomial coefficients (table), 2-21, 3-18
 - SC-2070 board, 2-20
 - SC-2071 board, 3-17 to 3-18
- lowpass filters
 - connecting to SC-2070 board, 2-18
 - thermocouple circuit with lowpass noise filter (figure), 2-19

- connecting to SC-2071 board, 3-15
 - thermocouple circuit with lowpass noise filter (figure), 3-16
- lowpass filters, building
 - SC-2070 board, 2-10 to 2-11
 - lowpass filter on differential channel 1 (figure), 2-12
 - normalized frequency response (figure), 2-10
 - SC-2071 board, 3-8 to 3-10
 - lowpass filter on channel 1 (figure), 3-10
 - normalized frequency response (figure), 3-9

M

- manual. *See* documentation.
- mounting
 - rack-mount chassis cover attachment, 5-9
 - rack mounting, 5-3 to 5-4
 - attaching mountable board to chassis (figure), 5-3
 - double-height mounting (figure), 5-4
 - locations for SC-207X boards (figure), 5-3
 - SC-2070 board, 2-6
 - SC-2071 board, 3-7
 - SC-2072 board, 4-7

N

- National Bureau of Standards (NBS) polynomial coefficients (table), 2-21, 3-18
- nonreferenced or floating signal sources, 2-7 to 2-8
 - differential inputs, 2-7
 - bias return resistor for DC-coupled floating source on channel 1 (figure), 2-8
 - single-ended inputs, 2-8
- nonreferenced single-ended (NRSE) input, 2-8

O

optional equipment, 1-4

P

parts locator diagram

SC-2070 board, 2-2

SC-2071 board, 3-2

SC-2072 board, 4-2

SC-2072D board, 4-3

physical specifications, A-2

polynomial coefficients of National Bureau of Standards (table), 2-21, 3-18

power connections

external, 5-4 to 5-5

amount of power supplied by DAQ devices (table), 5-6

SC-2072 board, 4-4 to 4-5

accidental shorting of terminals at J4 (warning), 4-5

setting switch S2 to position B (warning), 4-4

switch S2 settings for National Instruments DAQ devices (table), 4-4

power LED

SC-2070 board, 2-4

SC-2071 board, 3-4

SC-2072 board, 4-5

power requirements (from DAQ device), A-1

R

rack-mount chassis cover attachment, 5-9

rack mounting, 5-3 to 5-4

referenced single-ended input (RSE), 2-7

ribbon cable connectors, 5-8

S

SC-205X Series boards

connections with SC-2070 and SC-2071 boards (figure), 5-7

connectors compatible with SC-207X boards (table), 5-8

installing, 5-2

SC-207X Series boards. *See also* specific devices.

computers supported, 1-1

connections for DAQ devices (figure), 5-7

DAQ devices supported (table), 1-2

features, 1-1

getting started, 1-4

optional equipment, 1-4

software, 1-4

specifications, A-1 to A-2

unpacking, 1-5

SC-2070 board

analog input, 2-2 to 2-3

component positions in each channel (table), 2-3

onboard equivalent circuit (figure), 2-3

applications, 2-6 to 2-16

attenuators (voltage dividers), building, 2-15 to 2-16

channel configurations, 2-7

connecting ground-referenced signal sources, 2-9

differential inputs, 2-9

single-ended inputs, 2-9

connecting nonreferenced or floating signal sources, 2-7 to 2-8

differential inputs, 2-7 to 2-8

single-ended inputs, 2-8

highpass filters, building, 2-13 to 2-14

lowpass filters

building lowpass filters, 2-10 to 2-11

soldering and desoldering, 2-7

board-to-board cabling, 2-5 to 2-6

connecting to incompatible boards (warning), 2-6

connection using SC-2050 cable adapter board (figure), 2-6

DAQ devices used with SC-2070 (table), 2-5

direct connection to MIO-16 board (figure), 2-5

DAQ devices supported (table), 1-2

- digital and timing signals, 2-4 to 2-5
- features, 2-1
- fuse and power LED, 2-4
- installation, 5-1 to 5-2
- mounting, 2-6
- overview, 2-1
- parts locator diagram, 2-2
- screw terminal connections, 5-8
- shield ground, 2-4
- temperature sensor, 2-3 to 2-4
 - W1 jumper settings (figure), 2-4
- thermocouple measurements, 2-17 to 2-25
 - differential measurements, 2-22
 - example, 2-22 to 2-23
 - expected accuracies, 2-25
 - input filtering and broken thermocouple detection, 2-18 to 2-19
 - illustration, 2-19
 - linearizing the data, 2-20 to 2-21
 - National Bureau of Standards (NBS) polynomial coefficients (table), 2-21
 - selecting gain and input ranges, 2-19 to 2-20
 - thermocouple voltage output extremes (figure), 2-20
 - single-ended measurements, 2-23
 - example, 2-23 to 2-24
 - sources of error, 2-24
 - working with thermocouples, 2-17
- SC-2071 board
 - analog input, 3-2 to 3-3
 - component positions in each channel (table), 3-3
 - onboard equivalent circuit (figure), 3-3
 - applications, 3-7 to 3-14
 - attenuators (voltage dividers), building, 3-12 to 3-14
 - connecting floating signal sources, 3-8
 - connecting ground-referenced signal sources, 3-8
 - highpass filters, building, 3-10 to 3-12
 - lowpass filters, building, 3-8 to 3-10
 - soldering and desoldering, 3-7
 - board-to-board cabling, 3-5 to 3-7
 - connecting to incompatible boards (warning), 3-7
 - connection using SC-2053 cable adapter board (figure), 3-6
 - daisy-chaining Lab/1200 devices to BNC-2080 (figure), 3-6
 - DAQ devices used with SC-2071 (table), 3-5
 - direct connection to Lab/1200 devices (figure), 3-5
 - DAQ devices supported (table), 1-2
 - digital and timing signals, 3-5
 - features, 3-1
 - fuse and power LED, 3-4
 - installation, 5-1 to 5-2
 - mounting, 3-7
 - overview, 3-1
 - parts locator diagram, 3-2
 - screw terminal connections, 5-8
 - shield ground, 3-4
 - temperature sensor, 3-4
 - W1 jumper settings (figure), 3-4
 - thermocouple measurements, 3-15 to 3-21
 - expected accuracies, 3-20 to 3-21
 - input filtering and broken thermocouple detection, 3-15 to 3-16
 - illustration, 3-16
 - linearizing the data, 3-17 to 3-18
 - National Bureau of Standards (NBS) polynomial coefficients (table), 3-18
 - measurement connections, 3-18
 - selecting gain and input ranges, 3-16 to 3-17
 - thermocouple voltage output extremes (figure), 3-17
 - sources of error, 3-19 to 3-20
 - working with thermocouples, 3-14
- SC-2072 board
 - board-to-board cabling, 4-6
 - connecting to incompatible board (warning), 4-6
 - connection via SC-2072 board (figure), 4-6
 - direct connection to TIO-10 board (figure), 4-6

- DAQ devices supported (table), 1-2
- features, 4-1
- fuses and power LED, 4-5
- installation, 5-2
- mounting, 4-7
- overview, 4-1
- parts locator diagram, 4-2
- power connections, 4-4 to 4-5
 - accidental shorting of terminals at J4 (warning), 4-5
 - setting switch S2 to position B (warning), 4-4
 - switch S2 settings for National Instruments DAQ devices (table), 4-4
- screw terminal connections, 5-9
- signal connections, 4-3
- soldering and desoldering on, 4-7
- SC-2072D board. *See also* SC-2072 board.
 - parts locator diagram, 4-3
- screw terminal connections
 - SC-2070 and SC-2071, 5-8
 - SC-2072, 5-9
- Seebeck coefficient, 2-20, 3-17
- shield ground
 - SC-2070 board, 2-4
 - SC-2071 board, 3-4
- signal connections, 5-8 to 5-9
 - rack-mount chassis cover attachment, 5-9
 - ribbon cable connectors, 5-8
 - SC-205X Series board connectors
 - compatible with SC-207X boards (table), 5-8
 - SC-2072 board, 4-3
 - screw terminal connections
 - SC-2070 and SC-2071, 5-8
 - SC-2072, 5-9
- signal source connections
 - floating signal sources, SC-2071 board, 3-8
 - ground-referenced signal sources, 2-9
 - differential inputs, 2-9
 - SC-2071 board, 3-8
 - single-ended inputs, 2-9
 - nonreferenced or floating signal sources, 2-7 to 2-8
 - differential inputs, 2-7 to 2-8
 - single-ended inputs, 2-8

- signals
 - digital and timing
 - SC-2070 board, 2-4 to 2-5
 - SC-2071 board, 3-5
- single-ended inputs
 - ground-referenced signal sources, 2-9
 - nonreferenced or floating signal sources, 2-8
- single-ended thermocouple measurements, SC-2070 board, 2-23
 - example, 2-23 to 2-24
- soldering and desoldering
 - SC-2070 board, 2-7
 - SC-2071 board, 3-7
 - SC-2072 board, 4-7
- specifications
 - analog input, A-1
 - breadboarding area, A-1
 - environment, A-2
 - physical, A-2
 - power requirements (from DAQ device), A-1
- switches. *See* jumpers and switches.

T

- technical support, B-1
- temperature sensor
 - cold junction temperature sensor
 - specifications, A-1
 - SC-2070 board, 2-3 to 2-4
 - W1 jumper settings (figure), 2-4
 - SC-2071 board, 3-4
 - W1 jumper settings (figure), 3-4
- Thermocouple Law of Intermediate Metals, 2-17, 3-14
- thermocouple measurements
 - SC-2070 board. *See* SC-2070 board.
 - SC-2071 board. *See* SC-2071 board.
- thermocouple output voltages
 - linearizing
 - SC-2070 board, 2-20 to 2-21
 - SC-2071 board, 3-17 to 3-18
 - National Bureau of Standards (NBS)
 - polynomial coefficients (table), 2-21, 3-18
- thermocouples
 - definition, 2-17, 3-14

- purpose and use, 2-17, 3-14
- timing signals
 - SC-2070 board, 2-4 to 2-5
 - SC-2071 board, 3-5

U

- unpacking SC-207X Series boards, 1-5

V

- voltage dividers. *See* attenuators, building.