

PROline

Fridge Freezer USER'S MANUAL

PLC190W 



PLEASE READ THE USER'S OPERATION MANUAL CAREFULLY BEFORE USING

INDEX

Part names	01
Safety information	02
Installation	03
Electrical Connection (UK ONLY)	03
Instructions for use	04
Temperature Control	04
The Internal Light	04
Storage of fresh food in the refrigerator	05
Store frozen food	05
Freezing fresh food (Freezer)	05
Making ice cubes	05
Refrigerator defrost process	06
Freezer defrost process	06
Reversing the doors	07
Cleaning and maintenance	09
Changing the light bulb	09
Power Failure	09
If the appliance is not operating correctly	10
Prolonged off periods	10
Before calling for service	10
Do's and don'ts	11
Technical data	12
Important Disposal instructions	13
If something doesn't seem to work	13

PART NAMES

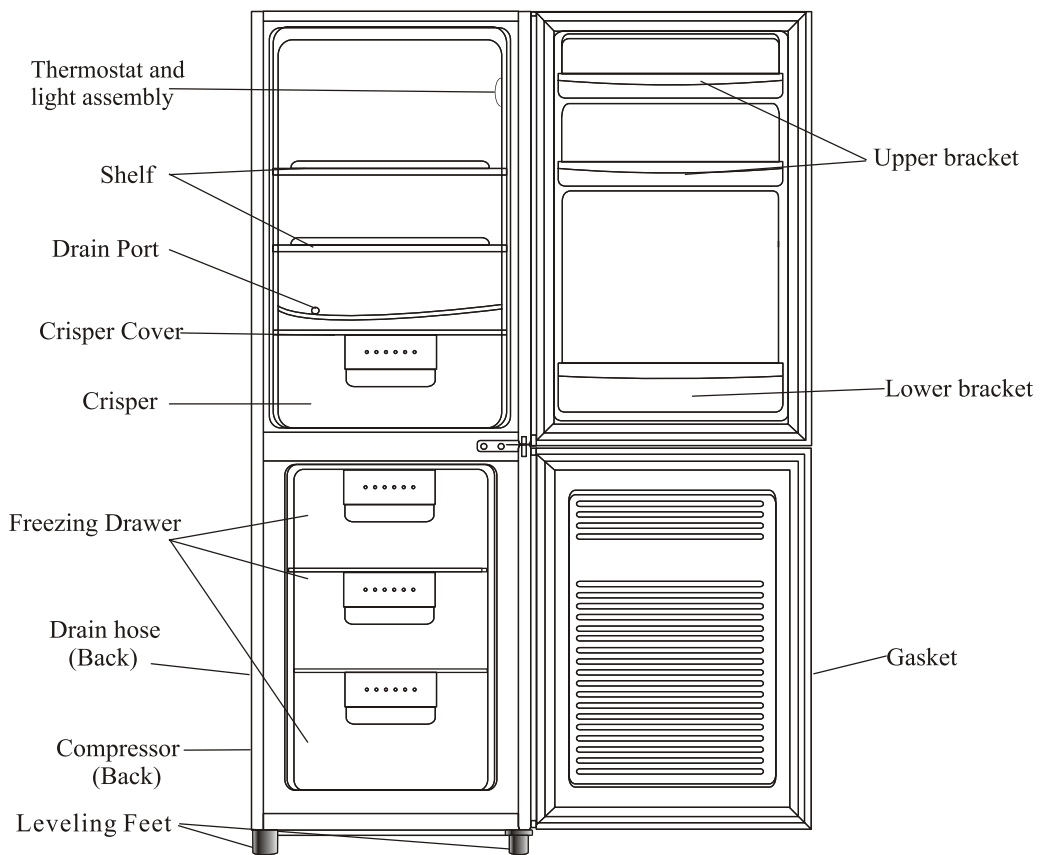

Note : Compartment design may change due to product improvement, No prior notice will be given.

This booklet contains the information you will require to install and operate your new appliance.

It is important and worthwhile spending time to fully read this booklet so you will understand how to operate the appliance safely and efficiently.

Please keep this booklet in a safe place so that you can refer to it when required.

Safety information

This information is provided in the interest of your safety. Please read the following carefully before carrying out the installation or use of the appliance.

If you are discarding an old freezer or refrigerator with a lock / catch fitted to the door, ensure that it is left in a disabled condition to prevent the entrapment of children whilst playing.

As old refrigeration equipment may contain CFC's which will damage the ozone layer, when disposing of any refrigeration equipment please contact your local waste disposal facility for advice on the correct method of disposal.

This appliance must only be used for its intended purpose i.e. the freezing and storage of domestic edible foodstuffs and should not be used for any other purpose

If the mains cable requires replacement, this must only be undertaken by a suitably qualified person, as special purpose tools are required.

WARNING:

This appliance is intended for domestic use only, any other use may invalidate the warranty and might be dangerous.

The refrigerating system must not be damaged at any time.

Installation

Position the appliance and allow to stand for two to three hours before it is turned on for the first time to allow the system to settle. Do not position next to any heat source e.g. cooker, boiler or in direct sunlight etc.

A clearance of 10 cm must be left between the sides of the appliance and any adjacent cabinets or walls to allow for adequate air circulation. The appliance is not designed for recessed installation (building in).

Install on a good firm level surface, and any unevenness of the floor should be corrected prior to installation, slight unevenness can be overcome by adjusting the front feet.

NOTE: If the appliance is positioned on a carpet, soft floor covering you should re-adjust the front feet once the appliance has had time to settle.

ELECTRICAL CONNECTION (UK ONLY)

For your safety please read the following information

Warning: This appliance must be earthed.

The appliance must be connected to a 220-240 volts 50 cycle AC supply by means of a three pin socket, suitably earthed and should be protected by a 13 amp fuse in the plug. The appliance is supplied with a rewirable 13 amp 3 pin plug fitted with a 13 amp fuse. Should the fuse require replacement, it must be replaced with a fuse rated at 13 amp and approved to BS1362.

If the mains plug is unsuitable for the socket outlet in your home or is removed for any other reason, then the cut off plug should be disposed of safely to prevent the hazard of electric shock.

There is a danger of electric shock if the cut off plug is inserted into any 13 amp socket outlet.

How to wire a 13 amp plug.

Make sure the cord is held tight by the cord clamp

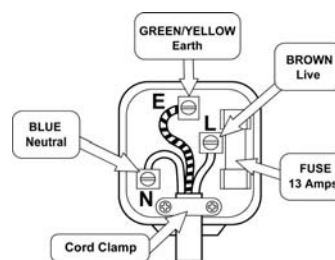

Important

The wires in the mains lead on this appliance are coloured in accordance with the following code:

Green and Yellow - Earth

Blue Neutral

Brown Live

As the colours may not correspond with the markings identifying the terminals in your plug proceed as follows.

The green and yellow wire must be connected to the terminal in the plug which is marked with the letter E or with the earth symbol \perp or coloured green and yellow.

The blue wire must be connected to the terminal marked N.

The brown wire must be connected to the terminal marked L.

Make sure the mains cord is held securely under the cord clamp.

Instructions for use

Remove all packing materials and wash the interior of the appliance using lukewarm water containing a little bicarbonate of soda in the proportion of 1 teaspoon to 1.2 liters (2 pints) of water. Do not use detergents or soaps as they may taint the food. After cleaning, dry all parts thoroughly.

Temperature Control

The refrigerator is designed to maintain an internal storage temperature in the refrigerator compartment between 0°C to + 10°C

To enable adjustment of the temperature in the appliance it is fitted with an adjustable thermostat located in the fridge compartment, which can be adjusted from setting 1 (warmest) to 7 (coldest). For normal working temperature it is recommended to adjust the thermostat control to the midway position, after a few hours readjust the thermostat to the desired temperature. There is also an off position "0". Which turns OFF the refrigerator and freezer compartments. Please Note this does not disconnect the appliance from the mains supply. To do this you must remove the mains plug from the socket.

To obtain a lower internal temperature turn the thermostat temperature control to a higher number. To obtain a higher internal temperature turn the thermostat control to a lower number. However, the internal temperature and temperature control setting is dependent on a number of factors:

1. Varying ambient temperatures.
2. The number of times the appliance doors are opened and how long the doors remain open.
3. The amount and temperature of the food and drink introduced into the appliance.
4. The weather conditions and time of year e.g. summer / winter.
5. The positioning of the appliance and an adequate air circulation to the sides and back of the cabinet.

Never place hot or warm foods into the cabinet or leave the doors open for longer than necessary as this will raise the temperature and cause excessive amounts of moisture thus increasing the amount of ice in the refrigerator / freezer compartment.

The Internal Light

The internal light will automatically switch ON and OFF whenever the refrigerator door is opened or closed. To change the light bulb, please see the chapter on changing the light bulb.

Storage of fresh food in the refrigerator

Food should always be covered tightly with foil, plastic film, placed in bags or stored in airtight containers. This will prevent food from dehydrating and prevent the strong smell of some foods transferring to milder ones.

To store raw meat wrap in polythene bags or airtight containers and place on the lowest shelf.

Do not allow raw meat to come into contact with cooked foods. For safety, only store raw meat for two or three days. Fruit and vegetables should be thoroughly cleaned and placed in the vegetable/ salad bin.

Milk and other liquids should be sealed with lids and placed in the bottle shelf on the door.

Store frozen food

When using the freezer for the first time or after defrosting, turn the thermostat temperature control to setting 7 for at least two hours before introducing the food to be stored, Then adjust to your preferred setting.

All frozen food products you purchase should be placed in the freezer as soon as possible to avoid the frozen food from defrosting.

Storage recommendations printed on the packaging of frozen food by the manufactures should always be followed.

Freezing fresh food (Freezer)

Ensure that your freezing operations are carried out under the most hygienic conditions, as freezing alone does not sterilize the food. Never put hot or even warm foodstuffs into the freezer. Prior to storing the food, pack it in plastic bags, aluminum foil or freezer containers and place into the freezer without putting them in contact with food that has already been frozen. See the technical data sheet at the rear of this booklet for the maximum permissible amount in kilograms of fresh food that can be frozen in any 24 hour period with a room temperature of 25C Never freeze more than the maximum permissible.

Making ice cubes (Ice tray not supplied)

Pour water into the ice cube tray until it is two thirds full and place into the freezer. Ice cubes will form in approximately 2 to 3 hours. The ice cube can be easily removed by twisting the ice cube tray or running under cold water for a short time.

Refrigerator defrost process

The refrigerator defrosting process is carried out automatically every time the compressor stops.

The defrost water drains from the cabinet into a tray placed on the top of the compressor to the rear of the unit where it evaporates.

Freezer defrost process

Small amounts of frost will accumulate inside the freezer depending upon the length of time during which the door is left open or the amount of moisture introduced. It is essential to ensure that no frost or ice is allowed to form at places where it will affect the close fitting of the door seal. This might allow air to penetrate the cabinet, thus encouraging continuous running of the compressor. Thin frost formation is quite soft and can be removed with a brush or plastic scraper. Do not use metal or sharp scrapers, mechanical devices or other means to accelerate the defrosting process. Remove all dislodged frost from the cabinet floor. For the removal of thin frost it is not necessary to switch off the appliance.

For the removal of heavy ice deposits disconnect the appliance from the mains supply and empty the contents into cardboard boxes and wrap in thick blankets or layers of paper to keep them cold. Defrosting will be most effective if carried out when the freezer is empty, and it should be carried out as quickly as possible.

An increase in temperature of frozen food packages during defrosting will shorten the storage life. Provided that the contents are well wrapped and placed in a cool area they should keep for several hours.

Examine the contents when replacing them in the freezer and if some of the packages have thawed out it should be eaten within 24 hours or be cooked and refrozen.

After defrosting has finished clean the inside with a solution of warm water with a little bicarbonate of soda and then dry thoroughly. Wash all removable parts in the same way and reassemble. Reconnect the appliance to the mains supply and leave for 2 to 3 hours on setting number 7 before introducing the food back into the freezer and setting the thermostat to your normal setting (usually setting 4.0).

Reversing the Doors

Before you reverse the refrigerator door, you should ensure the refrigerator is unplugged and empty and have someone to help you. During the process Screwdriver and adjustable spanner will be used.

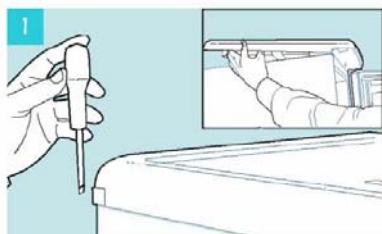

Undo the four retaining screws on the rear of the worktop and remove the worktop

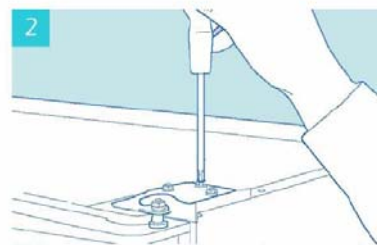

Undo the retaining screws of the top hinge and remove the top hinge. Then remove the upper door and put it in a safe place.

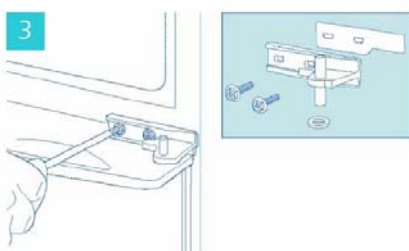

While supporting the lower door, remove the central hinge by removing the 2 screws. .



Remove the lower door from the bottom hinge pin. Tilt the fridge backwards and rest it on a firm surface .

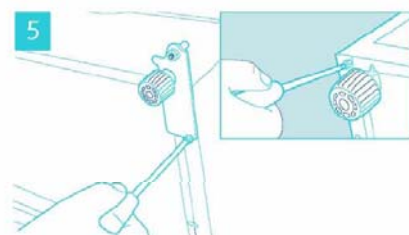

Remove the bottom hinge by removing the screws. Swap the adjustable foot from left side to right side removing the fixed screw in the left side first.



Remove the lower hinge pin using a spanner. Turn the hinge over and replace it in the same hole. Replace the bottom hinge on the other side and stand the refrigerator upright.

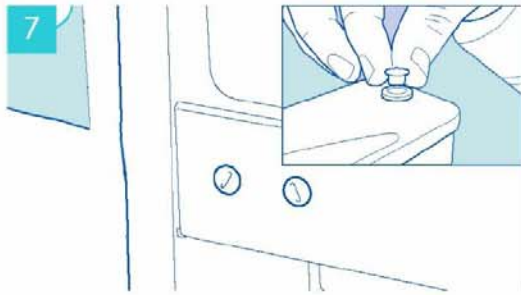

Reverse the blanking plugs. Remove the door hinge cap in the top of the freezer door and insert it on the opposite side of the door.

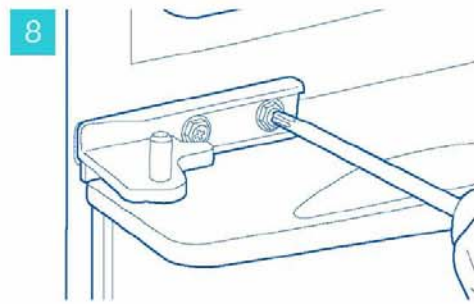

Replace the central hinge while refitting the lower door, To assist with final adjustment do not fully tighten the hinge screws.

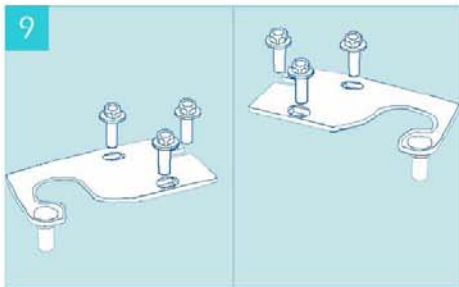

Unscrew the hinge pin from the top hinge using the spanner. Turn the hinge over and replace it in the same slot. (Reversed)

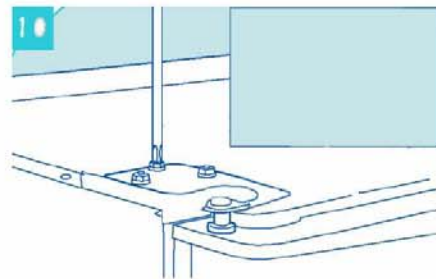

Refit the top hinge while refitting the upper door. Do not fully tighten screws.



Check that doors are aligned horizontally and vertically and that all seals are closed on the cabinet before finally tighten the central hinge and the top hinge . Remove and reverse the plastic insert of the worktop before refit the worktop. Re-adjust the levelling feet.

Cleaning and maintenance

Before any cleaning or maintenance is carried out you must disconnect the appliance from the mains supply by removing the plug, never remove the plug by pulling on the mains cord. Remove the plug by pulling on the plug itself.

It is recommended that when cleaning the appliance, both the inside and outside, can be cleaned using warm water and a little bicarbonate of soda. Use 1 teaspoon to 1.2 litres of water.

If the appliance is not to be used for a long period of time then it is recommended to remove all the food stuff, clean the inside of the appliance and leave the door open to allow the air to circulate thus avoiding unpleasant odors.

Changing the light bulb

Note. Light bulbs are not covered by the warranty

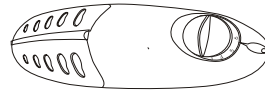

Disconnect the appliance from the mains supply.

Pull the lamp cover forwards, to gain access to the lamp. Unscrew the light bulb in an anti-clockwise direction from the holder.

Replace the bulb with one of the correct type and size (10 watt E14 base).

Replace the cover by Pushing the cover Backwards.

Reconnect the appliance to the mains supply.

Power Failure

If there is a power failure for a short time less than 12 hrs keep the door closed

Frozen food should not be affected if the failure lasts for less than 12 hrs.

Extra protection can be given by covering the appliance with two or three thick blankets.

If a long power failure is anticipated, try to get the foodstuff into another appliance or cold store, if possible.

If the power cut is longer than 12 hrs then check the content of the freezer.

If the food has defrosted, cook and refreeze the food or it should be eaten immediately.

Never refreeze food that has been defrosted.

If the appliance is not operating correctly:

Please check the following points.

Is there a power failure? (Check by turning on a house light)

Has the fuse blown or has the circuit breaker tripped.

Has the door been closed correctly?

Check the thermostat has been set correctly.

Check the mains plug is seated in the wall socket correctly and the socket switch is on.

Check the power outlet is working, Try another appliance.

Is the room temperature too cold or too hot. (working temperature range 16°C to 32°C)

Prolonged off periods

If the refrigerator is not in use for a long period of time, proceed as follows:

Disconnect the refrigerator from the main supply by removing the plug from the socket.

Clean and dry the inside as instructed under the heading of cleaning the appliance.

Leave the door open to prevent any unpleasant smells from building up while the appliance is not in use.

If there is a power failure for a short time keep the door closed check the contents of the refrigerator every so often.

Before calling for service

Please check the following points:

1. The refrigerator is not working

Check the plug is inserted correctly into the wall socket

Check there is power to the wall socket by plugging in another appliance, if the other appliance works, check the fuse in the appliance plug.

2. The refrigerator is noisy when running

Check the appliance is level and is not in contact with another appliance or kitchen furniture.

3. The refrigerator does not cool sufficiently.

If the door has been opened too often, or it has been left open for a while it will take time for the appliance to reach its set temperature.

Check the air flow around the refrigerator has not been reduced due to insufficient clearance.

NOTE: The following characteristics should not be looked upon as a problem.

A gentle trickling sound caused by coolant flowing through the pipe.

Compressor operating at high temperature.

Do's and don'ts

Do- keep raw meat and poultry below cooked food and dairy products.

Do- Leave lettuce, cabbage, parsley and cauliflower on the stem.

Do- Wrap cheese firstly in greaseproof paper and then in a polythene bag, excluding As much air as possible. For best results, take out of the fridge compartment an hour before eating.

Do- Wrap raw meat and poultry loosely in polythene or aluminium foil. This prevents drying.

Do- Wrap fish and offal in polythene bags.

Do- Wrap food with a strong odour or which may dry out, in polythene bags, or aluminium foil or place in airtight container.

Do- Wrap bread well to keep it fresh.

Do- Chill white wines, beer, lager and mineral water before serving.

Do- Check contents of the low temp compartment every so often.

Do- Keep food for as short a time as possible and adhere to "best before" and "Use by" etc. dates.

Do- Store commercially prepared food in accordance with the instructions given on the packets.

Do- Always choose high quality fresh food and be sure it is thoroughly clean before Storing it.

Do- Wrap all food in aluminium foil or food quality polythene bags and make sure any air is excluded.

Do-Keep ventilation openings, in the appliance enclosure clear of obstruction.

Do-ensure that frozen food does not rise in temperature while defrosting, a rise in temperature during defrosting may shorten the storage life of your food.

Don't- Cover the shelves with any protective materials which may obstruct air circulation.

Don't- Store poisonous or any dangerous substances in your fridge. It has been designed for the storage of edible foodstuffs only.

Don't- Consume food which has been refrigerated for an excessive length of time.

Don't- Store cooked and fresh food together in the same container. They should be packaged and stored separately.

Don't- Let defrosting food or food juices drip onto already stored food.

Don't- leave the door open for long periods, as this will make the appliance more costly to run and cause excessive ice formation.

Don't- Use sharp edged objects such as knives or forks to remove the ice.

Don't- Use hairdryers, or electrical appliances for defrosting only use item recommended by the manufacturer.

Don't- put hot food into the appliance. Let it cool down first.

Don't- put liquid-filled bottles or sealed cans containing carbonated liquids into the freezer section, as they may burst.

Don't- Give children ice cream and water ices direct from the freezer section. The low temperature may cause 'freezer burns' on the lips.

Don't- Try to keep frozen food which has thawed; it should be eaten within 24 hours or cooked and refrozen.

Don't- Damage the refrigerant circuit at any time

Technical data

Brand	Proline
Appliance type	Fridge-Freezer Type I
Star rating	***
Frequency (Hz)	50 Hz
Light Power (Watts)	10W
Net Freezer volume	53L
Net Refrigerator Volume	92L
Freezing capacity (kg/24h)	2.0kg/24h
Rated Voltage (V)	220-240V~
Climate Class +Ambient Range	N (+16°C to 32°C)
Gross Weight (Kg)	48Kg
Energy consumption (kWh/24h)	0.69kWh/24h
Energy Consumption (kWh/year)	252kWh/year
Input Power (Watts)	120W
Refrigerating agent	R600a/41g
Outside dimensions (W x D x H)	480×530×1450
Insulation Blowing Gas	C-Pentane
Energy class	A

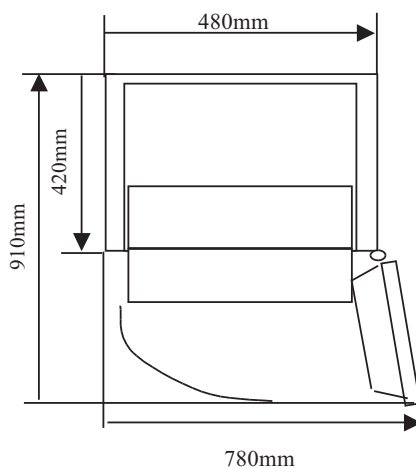

IMPORTANT DISPOSAL INSTRUCTIONS



As a responsible retailer we care about the environment.

As such we urge you to follow the correct disposal procedure for your product and packaging materials. This will help conserve natural resources and ensure that it is recycled in a manner that protects health and the environment.

You must dispose of this product and its packaging according to local laws and regulations.

Because this product contains electronic components, the product and its accessories must be disposed of separately from household waste when the product reaches its end of life.

Contact your local authority to learn about disposal and recycling.

The product should be taken to your local collection point for recycling. Some collection points accept products free of charge.

If something doesn't seem to work

If there is something about your appliance which you do not understand and you live in the UK you can phone our help line during normal office hours on: 0113 2793520

Calls are charged at standard rates.

We apologise for any inconvenience caused by minor inconsistencies in these instructions, which may occur as a result of product improvement and development.

Kesa U.K., HU1 3AU 16/04/2008