

# **WMP-176**

**Medical Panel PC**

## USER'S MANUAL

P/N: 205G000WMP17X2, V1.1

Copyright©,2012. All rights reserved

All other brand names are registered trademarks of their respective owners.

The information contained in this document is subject to change without notice.

---

## Version Change History

<b>Date</b>	<b>Version</b>	<b>Description</b>	<b>Remark</b>
2012/8/17	1.0	First release	James.Chiu
2012/9/12	1.1	Modify features Modify unit input rating	James.Chiu

---

## Acknowledgments

- Intel® 2nd generation Core i and Celeron are registered trademarks of Intel® Corporation.
- IBM, PC/AT, PS/2 are trademarks of International Business Machines Corporation.
- Microsoft® Windows is a registered trademark of Microsoft® Corporation.
- RTL is a trademark of Realtek Semi-Conductor Co., Ltd.
- C&T is a trademark of Chips and Technologies, Inc.
- UMC is a trademark of United Microelectronics Corporation.
- ITE is a trademark of Integrated Technology Express, Inc.
- VIA is a trademark of VIA Technology, Inc.
- Award is a registered trademark of Award Software International, Inc.
- PS/2 is a trademark of International Business Machines Corporation.
- Intel is a trademark or registered trademark of Intel Corporation.
- Microsoft Windows is a registered trademark of Microsoft Corporation.
- Winbond is a registered trademark of Winbond Electronics Corporation.

**All other product names or trademarks are properties of their respective owners.**

---

## FCC Class B

This equipment has been tested and found to comply with the limits for a Class B digital device, pursuant to Part 18 of the FCC Rules.

These limits are designed to provide reasonable protection against harmful interference when the equipment is operated in a residential environment. This equipment generates, uses and can radiate radio frequency energy. If not installed and used in accordance with this user manual, it may cause harmful interference to radio communications.

Note that even when this equipment is installed and used in accordance with this user manual, there is still no guarantee that interference will not occur. If this equipment is believed to be causing harmful interference to radio or television reception, this can be determined by turning the equipment on and off. If interference is occurring, the user is encouraged to try to correct the interference by one or more of the following measures:

- Reorient or relocate the receiving antenna
- Increase the separation between the equipment and the receiver
- Connect the equipment to a power outlet on a circuit different from that to which the receiver is connected
- Consult the dealer or an experienced radio/TV technician for help

### **Warning:**

*Any changes or modifications made to the equipment which are not expressly approved by the relevant standards authority could void your authority to operate the equipment.*

*To avoid risk of electric shock, this equipment must only be connected to a supply mains with protective earth.*

*Do not modify this equipment without authorization of the manufacturer.*

---

## **Safety Instructions**

### **Intended use**

The WMP-176 is intended to serve as a medical monitor which is designed for general purpose for hospital environment and for diagnosis. It could be used for Surgical, Radiology, PACS (Picture Archiving Communication Systems), LIS (Lab Information Systems) and Electronic Medical Record purpose. It shall not be used for life-supporting system.

**WARNING:** Critical diagnostic decision must not be based solely on images displayed by this device

### **Greeting & Setup**

Thank you for purchasing the WMP-176 unit. We wish that this unit will be durable and reliable in providing your medical application needs. Please follow the instructions below to ensure the unit continues to have high performance.

### **Unpacking**

After opening the carton, there will be a medical panel PC unit with an accessory box. Examine the contents to see if there are damages to the unit and if all accessories are present.

### **Setting up**

Please read this manual carefully and remember to keep this manual for future reference.

### **Safety Instructions & Cleaning**

The unit has undergone various tests in order to comply with safety standards. Inappropriate use of the open frame unit may be dangerous. Please remember to follow the instructions below to insure your safety during the installation and operating process.

### **Transporting & Placement of unit**

1. When moving the unit on a cart; be very cautious. Quick stops, excessive forces and uneven surfaces may cause the cart to overturn thus risking the unit to fall to the ground.

- 
2. If the medical panel PC unit does fall to the ground, immediately turn the power off and disconnect cords. Then contact a service technician for repairs. Continual use of the unit may result cause a fire or electric shock. Also, do not repair the unit on your own.
  3. Having two or more people transporting the display unit is recommended. In addition, when installing the unit by suspending it also requires two or more people.
  4. Before suspending the unit, make sure the material used for suspension is sturdy and stable. If not properly suspended, the display unit may fall and cause serious injury to people standing nearby as well as to the unit itself.
  5. If you wish to mount the display unit, remember to use only the mounting hardware recommended by the manufacturer.

### **Electrical and Power Source Related**

1. This medical panel PC unit must operate on a power source as shown on the specification label. If you are not sure what type of power supply used in the area, consult your dealer or local power supplier.
2. The power cords must not be damaged. Applied pressure, added heat, and tugging may damage the power cord.
3. The power cord must be routed properly when setup takes place. We advise that this aspect measure is to prevent people from stepping on the cords or while the unit is suspended to prevent flying objects from getting tangled with the unit.
4. Do not overload the AC outlets or extension cords. Electrical shocks or fires may occur from overloading.
5. Do not touch the power source during a thunderstorm.
6. If your hands are wet, do not touch the plug.
7. Use your thumb and index finger, grip firmly on the power cord to disconnect from the electrical socket. By pulling the power cord, may result in damaging it.

- 
8. If the unit is not going to be in use for an extended period of time, remember to disconnect the unit.
  9. The medical panel PC unit uses voltage between 100-240VAC. Connect the unit to a power source with the same numerical value as shown. Please use only the power cord provided by the dealer to ensure safety and EMC compliance.

### **Various Factors of Environment**

1. Do not insert objects into the openings.
2. Do not have liquids seep into the internal areas of the medical panel PC unit.
3. Having liquids seep in or inserting objects into the unit may result in electric shocks from taking and/or short circuiting the internal parts.
4. Do not place the medical panel PC unit in the presence of high moisture areas.
5. Do not install the medical panel PC unit in a wet environment.
6. Do not place near unit near heat generating sources.
7. Do not place the unit in a location where it will come in contact with fumes or steam.
8. Remember to keep the medical panel PC unit away from the presence of dust.
9. If water has flow in or seep in, immediately disconnect the open frame unit. Then contact a service technician for repairs.

### **Ventilation Spacing**

1. Do not cover or block the openings on the top and back sides of the display unit. Inadequate ventilation may cause overheating thus reducing the lifespan of the unit.
2. Unless proper ventilation is present, do not place unit in an enclosed area; such as a built-in shelf. Keep a minimum distance of 10 cm between the display unit and wall.

---

## **Cleaning the unit**

1. Remember to turn off the power source and to unplug the cord from the outlet before cleaning the unit.
2. Carefully dismount the unit or bring the unit down from suspension to clean.
3. Please use a dry soft cloth to clean the unit.
4. Take a dry cloth and wipe the unit dry. Remember to avoid having liquids seep into the internal components and areas of the medical panel PC unit.





## **Servicing, Repairing, Maintenance & Safety Checks**

1. If the unit is not functioning properly, observe the performance level of the display closely to determine what type of servicing is needed.
2. Do not attempt to repair the medical panel PC unit on your own. Disassembling the cover exposes users' to high voltages and other dangerous conditions. Notify and request a qualified service technician for servicing the unit.
3. To avoid risk of electric shock, this equipment must only be connected to a supply mains with protective earth.
4. If any of the following situations occur turn the power source off and unplug the unit. Then contact a qualified service technician.
  - (a) A liquid was spilled on the unit or objects have fallen into the unit.
  - (b) The unit is soaked with liquids.
  - (c) The unit is dropped or damaged.
  - (d) If smoke or strange odor is flowing out of the operating unit.
  - (e) If the power cord or plug is damaged.
  - (f) When the functions of the unit are dysfunctional.
5. When replacement parts are needed for the medical panel PC unit, make sure service technicians use replacement parts specified by the manufacturer, or those with the same characteristics and performance as the original



---

parts. If unauthorized parts are used it may result in starting a fire, electrical shock and/or other dangers.

	ISO 7000-0434 : Caution, consult ACCOMPANYING DOCUMENTS.
	ISO 7000-1641 : Follow operating instructions or Consult instructions for use.
	IEC 60417 -5009 : STAND-BY.
	IEC 60417-5031 : Direct current.
	<p>EU-wide legislation, as implemented in each Member State, requires that waste electrical and electronic products carrying the mark (left) must be disposed of separately from normal household waste. This includes monitors and electrical accessories, such as signal cables or power cords. When you need to dispose of your display products, please follow the guidance of your local authority, or ask the shop where you purchased the product, or if applicable, follow any agreements made between yourself.</p> <p>The mark on electrical and electronic products only applies to the current European Union Member States.</p>

---

When networking with electrical devices, the operator is responsible for ensuring that the resulting system meets the requirements set forth by the following standards:

– **EN 60601-1 (IEC 60601-1)**

Medical electrical equipment

Part 1: General requirements for safety

– **EN 60601-1-1 (IEC 60601-1-1)**

Medical electrical equipment

Part 1-1: General requirements for safety

Collateral standard: Safety requirements for

Medical electrical systems

– **EN 60601-1-2 (IEC 60601-1-2)**

Medical electrical equipment

Part 1-2: General requirements for safety

Collateral standard: Electromagnetic compatibility;

Requirements and tests

Accessory equipment connected to the analog and digital interfaces must be in compliance with the respective nationally harmonized IEC standards (i.e. IEC 60950 for data processing equipment, IEC 60065 for video equipment, IEC 61010-1 for laboratory equipment, and IEC 60601-1 for medical equipment.) Furthermore all configurations shall comply with the system standard IEC 60601-1-1. Everybody who connects additional equipment to the signal input part or signal output part configures a medical system, and is therefore, responsible that the system complies with the requirements of the system standard IEC 60601-1-1. The unit is for exclusive interconnection with IEC 60601-1 certified equipment in the patient environment and IEC 60XXX certified equipment outside of the patient environment. If in doubt, consult the technical services department or your local representative.



3SZJ

E355176

With Respect To Electric Shock,  
Fire And Mechanical Hazard Only In  
Accordance With ANSI/AAMI ES60601-1.  
CAN/CSA C22.2 No. 60601-1

---

**Caution:**

*DO NOT LEAVE THIS EQUIPMENT IN AN UNCONTROLLED ENVIRONMENT WHERE THE STORAGE TEMPERATURE IS BELOW -20° C (-4° F) OR ABOVE 60° C (140° F). THIS MAY DAMAGE THE EQUIPMENT.*

*This equipment shall not be used in life support systems.*

*The user is not to touch SIP/SOPs and the patient at the same time.*

*Caution – Use suitable mounting apparatus to avoid risk of injury.*

The sound pressure level at the operator's position according to IEC 704-1:1982 is no more than 70dB (A).

- A) Grounding reliability can only be achieved when the equipment is connected to an equivalent receptacle marked "Hospital Only" or "Hospital Grade".
- B) Use a power cord that matches the voltage of the power outlet, which has been approved and complies with the safety standard of your particular country.
- C) Caution: This adapter Sinpro MPU101-105 is a forming part of the medical device

**Contact information:**

3F, No.14, Prosperity Road II, Science-Based Industrial Park,  
Hsinchu, Taiwan 300, R.O.C

TEL: (886) 3 5780000

E-Mail: Sales@wincomm.com.tw

---

# Table of Contents

Acknowledgments .....	iii
FCC Class B.....	iv
Safety Instructions .....	v
<b>Introduction .....</b>	<b>1</b>
Product Description .....	1
Package list.....	2
Features .....	3
Specifications .....	4
Guidance and manufacturer’s declaration – electromagnetic emissions .....	6
Guidance and manufacturer’s declaration – electromagnetic immunity .....	7
Guidance and manufacturer’s declaration – electromagnetic immunity .....	9
Immunity.....	9
Cleaning/Disinfecting .....	11
<b>Getting Started .....</b>	<b>12</b>
System Set Up.....	12
Dimension.....	13
System View .....	14
Disconnect Device.....	17
<b>BIOS Setup .....</b>	<b>18</b>
<b>Appendix.....</b>	<b>28</b>
A. Jumper settings and Connectors .....	28
B. VESA Mounting (optional kit) .....	51
C. Battery Pack Specifications (optional kit) ..	53
D. How to disable battery when system hang up on WMP-176.....	54
E. Scrap Computer Recycling.....	55

---

## Introduction

### Product Description

---

The WMP-176 Medical Panel PC are based on Intel *2nd generation Core i* processor which can deliver faster graphic with higher CPU performance. It accommodates one 2.5" SATA II hard disk drive and up to 8GB DDR3 SODIMM.

The high brightness LCD, Low Noise solution, integrated multimedia functions and extensive expansion options make them the perfect platform upon which to build comprehensive lifestyle computing applications.

The WMP-176 includes all the features of a powerful computer into a slim and attractive chassis. The WMP-176 has a 17" high brightness TFT display with 1280 x 1024 resolution.

The WMP-176 is compact, two Giga LAN and selectable WLAN network compatible PC with full safety and medical approval and features to control a dedicated system with a wide variety of applications. Combining the WMP-176 into your system can achieve both cost-saving and efficient improvements.

Common applications include Surgical, Radiology, PACS (Picture Archiving Communication Systems), LIS (Lab Information Systems) and Electronic Medical Record. The WMP-176 are definitely your perfect choice.

---

## **Package list**

---

---

Before you begin installing your Medical Station, please make sure that the following items have been shipped:

- The WMP-176 Medical Panel PC unit
- One CD containing user manual, chipset drivers
- Power Adapter x 1 (Mf:Sinpro, type/model: MPU101-105)
- Power cord – Hospital grade used(US type), or other type in UK, EU...etc.
- Stylus pen x 1 (By configuration)
- Screw x 8 (VESA 75/100 use)

---

## Features

---

- 17" True Color Diagnostic Panel
- IP65 at front side, IPX1 for whole system
- High performance intel® 2nd generation Core i series mobile CPU
- Two mini PCI-e expansion
- HDD Anti-vibration mechanism (For Nursing cart)
- Low noise Smart fan solution
- Anti-bacteria coating (Against **Escherichia coli** & **Staphylococcus Aureus**)
- Built-in Battery backup function (option)
- Video Graphic card (option)
- Supports PCI-E x 16 (or PCI 2.2) (option)
- Temper glass as option

---

# Specifications

---

## Hardware Specifications

Display	17" 380 nits SXGA color TFT LCD
CPU Support	Intel® socket rPGA988B Core™ i5-2410M (3M Cache, 2.30 GHz) 35W Intel® socket PGA988B Celeron™ B810 (2M Cache, 1.60 GHz) 35W
Disk Drive Space	2.5" Hard Disk Drive (SATA II)
Expansion	Two Mini PCIe slot; One PCI expansion (load 10.78W) or one PCI-E expansion slot
Button	Brightness down/Brightness up // Power // Volume down/Volume up
I/O	<b>Standard version</b> 1 RS-232 port + 1 RS-232/422/485 port 4 USB 2.0 ports 1 DC-in w/ lock function 2 Gigabit LAN RJ-45 Connectors <i>Sound:</i> 1 x Line-in 1 x line-out 2 x 2 Speakers on back side Optional: PCI or PCI-E slot x 1

## LCD Specifications

Model Name	G170EG01 (V0)
Display Type	17" color TFT LCD
Max. Resolution	1280 x 1024
Contrast Ratio	1000 : 1 (Typ)
Pixel Pitch (mm)	0.264 (per one triad) x 0.264
Luminance (cd/m2)	380 (TYP)
Viewing Angle	170°(H) 160°(V)
Operating Temperature	0°C~ 40°C (32°F~104°F)
Brightness Control	Yes

## Power Adapter Specifications

Power	Close-frame
MFR	Sinpro



Type	MPU101-105
Input Voltage	AC 100 ~ 240 V, 1.25 – 0.5A @ 47 ~ 63 Hz
Output Voltage	DC 12V @ 8.33 A
MTBF	100,000 hrs operation at 25°C

### Mechanical Specifications

Architecture	Close-frame
Front Bezel	PET bezel with resistive touch screen
Color	Medical-white
Mounting / Holder	VESA 75/100mm
Construction	3mm ABS + PC TYPE Plastic housing
Dimension (WxHxD)	420mmx 360mm x 83 mm
Net Weight	6.5kg (w/o power adapter)
Packing Filler	PE

### Environmental Specifications

Temperature	Operating: 0°C to 40°C (32°F ~104°F) Storage, Transportation: -20°C to 60°C (-4°F ~140°F)
Humidity	Operating: 10% to 90%, non-condensing Storage, Transportation: 10% to 90% @ 40°C, non-condensing
Vibration	Operating: 15g/0.53 oz, 11 ms, half sine wave Non-operating: 50g/1.76 oz, 11 ms, half sine wave
Shock	Operating: 5 ~ 17 Hz , Amplitude : 0.117 ~ 500Hz , Acceleration : 1.0G Non-operating: 10~55Hz/0.15g, 55~500Hz/2.0g
Altitudes	Operational: up to 3000 m (9842 feet) Shipping: up to 12192 m (40000 feet)
Pressure	700 – 1060 hPa (Operation) 186 – 1060 hPa (Storage) 186 – 1060 hPa (Transportation)
Input Power Rating	For Adaptor: AC100~240 V, 1.25 – 0.5A, @47 ~ 63 Hz. For Unit: DC 12V, 8.33A

Power Consumption	96W Max (Typical: 79.5W )
-------------------	---------------------------

### Touch Screen

Type	5-wire, Analog Resistive
Interface	USB interface
Resolution	2048 x 2048
Light Transmission	80% ± 3%
Life Time	35 million activations

<b>Guidance and manufacturer's declaration – electromagnetic emissions</b>		
The model WMP-176 is intended for use in the electromagnetic environment specified below. The customer or the user of the model WMP-176 should assure that it is used in such an environment.		
<b>Emissions test</b>	<b>Compliance</b>	<b>Electromagnetic environment – guidance</b>
RF emissions CISPR 11		The model WMP-176 uses RF energy only for its internal function. Therefore, its RF emissions are very low and are not likely to cause any interference in nearby electronic equipment.
RF emissions CISPR 11		The model WMP-176 is suitable for use in all establishments, including domestic establishments and those directly connected to the public low-voltage power supply network that supplies buildings used for domestic purposes.
Harmonic emissions IEC 61000-3-2		
Voltage fluctuations/ flicker emissions IEC 61000-3-3		
<b>Recommended separation distances between portable and mobile RF communications equipment and the model WMP-176</b>		

The model WMP-176 is intended for use in an electromagnetic environment in which radiated RF disturbances are controlled. The customer or the user of the model WMP-176 can help prevent electromagnetic interference by maintaining a minimum distance between portable and mobile RF communications equipment (transmitters) and the model WMP-176 as recommended below, according to the maximum output power of the communications equipment.

Rated maximum output power of transmitter W	Separation distance according to frequency of transmitter m		
	150 kHz to 80 MHz $d = 1,2 \sqrt{P}$	80 MHz to 800 MHz $d = 1,2 \sqrt{P}$	800 MHz to 2,5 GHz $d = 2,3 \sqrt{P}$
0,01	0,12	0,12	0,23
0,1	0,38	0,38	0,73
1	1,2	1,2	2,3
10	3,8	3,8	7,3
100	12	12	23

For transmitters rated at a maximum output power not listed above, the recommended separation distance in meters (m) can be estimated using the equation applicable to the frequency of the transmitter, where  $P$  is the maximum output power rating of the transmitter in watts (W) according to the transmitter manufacturer.

NOTE 1 At 80 MHz and 800 MHz, the separation distance for the higher frequency range applies.

NOTE 2 These guidelines may not apply in all situations. Electromagnetic propagation is affected by absorption and reflection from structures, objects and people.

### Guidance and manufacturer's declaration – electromagnetic immunity

The model WMP-176 is intended for use in the electromagnetic environment specified below. The customer or the user of the model WMP-176 should assure that it is used in such an environment.

Immunity test	IEC 60601 test level	Compliance level	Electromagnetic environment – guidance
---------------	----------------------	------------------	--

Electrostatic discharge (ESD) IEC 61000-4-2	$\pm 6$ kV contact $\pm 8$ kV air	$\pm 6$ kV contact $\pm 8$ kV air	Floors should be wood, concrete or ceramic tile. If floors are covered with synthetic material, the relative humidity should be at least 30 %.
Electrical fast transient/burst IEC 61000-4-4	$\pm 2$ kV for power supply lines $\pm 1$ kV for input/output lines	$\pm 2$ kV for power supply lines $\pm 1$ kV for input/output lines	Mains power quality should be that of a typical commercial or hospital environment.
Surge IEC 61000-4-5	$\pm 1$ kV line(s) to line(s) $\pm 2$ kV line(s) to earth	$\pm 1$ kV line(s) to line(s) $\pm 2$ kV line(s) to earth	Mains power quality should be that of a typical commercial or hospital environment.
interruptions and voltage variations on power supply input lines IEC 61000-4-11	$< 5$ % <i>UT</i> ( $> 95$ % dip in <i>UT</i> ) for 0,5 cycle  $40$ % <i>UT</i> (60 % dip in <i>UT</i> ) for 5 cycles  $70$ % <i>UT</i> (30 % dip in <i>UT</i> ) for 25 cycles  $< 5$ % <i>UT</i> ( $> 95$ % dip in <i>UT</i> ) for 5 sec	$< 5$ % <i>UT</i> ( $> 95$ % dip in <i>UT</i> ) for 0,5 cycle  $40$ % <i>UT</i> (60 % dip in <i>UT</i> ) for 5 cycles  $70$ % <i>UT</i> (30 % dip in <i>UT</i> ) for 25 cycles  $< 5$ % <i>UT</i> ( $> 95$ % dip in <i>UT</i> ) for 5 sec	Mains power quality should be that of a typical commercial or hospital environment. If the user of the model WMP-176 requires continued operation during power mains interruptions, it is recommended that the model WMP-176 be powered from an uninterruptible power supply or a battery.

Power frequency (50/60 Hz) magnetic field  IEC 61000-4-8	3 A/m	3 A/m	Power frequency magnetic fields should be at levels characteristic of a typical location in a typical commercial or hospital environment.
--	-------	-------	---

NOTE *UT* is the a.c. mains voltage prior to application of the test level.

**Guidance and manufacturer's declaration – electromagnetic immunity**

The model WMP-176 is intended for use in the electromagnetic environment specified below. The customer or the user of the model WMP-176 should assure that it is used in such an environment.

Immunity	IEC 60601 test level	Compliance level	Electromagnetic environment – guidance
Conducted RF IEC 61000-4-6  Radiated RF IEC 61000-4-3	3 Vrms 150 kHz to 80 MHz  3 V/m 80 MHz to 2,5 GHz	Vrms  V/m	<p>Portable and mobile RF communications equipment should be used no closer to any part of the model WMP-176, including cables, than the recommended separation distance calculated from the equation applicable to the frequency of the transmitter.</p> <p><b>Recommended separation distance</b></p> $d = 1,2 \sqrt[3]{P}$ $d = 1,2 \sqrt[3]{P} \quad 80 \text{ MHz to } 800 \text{ MHz}$ $d = 2,3 \sqrt[3]{P} \quad 800 \text{ MHz to } 2,5 \text{ GHz}$ <p>where <i>P</i> is the maximum output power rating of the transmitter in watts (W) according to the transmitter manufacturer and <i>d</i> is the recommended separation distance in meters (m).</p> <p>Field strengths from fixed RF transmitters, as determined by an electromagnetic site survey, <sup>a</sup> should be less than the compliance level in each frequency range. <sup>b</sup></p> <p>Interference may occur in the vicinity of equipment marked with the following symbol:</p> 

NOTE 1 At 80 MHz and 800 MHz, the higher frequency range applies.

NOTE 2 These guidelines may not apply in all situations. Electromagnetic propagation is affected by absorption

and reflection from structures, objects and people.

---

<sup>a</sup> Field strengths from fixed transmitters, such as base stations for radio (cellular/cordless) telephones and land mobile radios, amateur radio, AM and FM radio broadcast and TV broadcast cannot be predicted theoretically with accuracy. To assess the electromagnetic environment due to fixed RF transmitters, an electromagnetic site survey should be considered. If the measured field strength in the location in which the model WMP-176 is used exceeds the applicable RF compliance level above, the model WMP-176 should be observed to verify normal operation. If abnormal performance is observed, additional measures may be necessary, such as reorienting or relocating the model WMP-176.

<sup>b</sup> Over the frequency range 150 kHz to 80 MHz, field strengths should be less than V/m.

---

## **Cleaning/Disinfecting**

---

### **Steps:**

1. Wipe the WMP-176 with a dry clean cloth.
2. Prepare agent per manufacturer's instructions or hospital protocol.

### **Cautions:**

- Do not immerse or rinse the WMP-176 and its peripherals. If you accidentally spill liquid on the device, disconnect the unit from the power source. Contact your Biomed regarding the continued safety of the unit before placing it back in operation.
- Do not spray cleaning agent on the chassis.
- Do not use disinfectants that contain phenol.
- Do not autoclave or clean the WMP-176 or its peripherals with strong aromatic, chlorinated, ketone, ether, or Esther solvents, sharp tools or abrasives. Never immerse electrical connectors in water or other liquids.

---

# Getting Started

## System Set Up

---

---

The following is a summary of the steps in setting up the system for use.

- (1). You can fix the system to a mounting fixture using the screw holes on the sides of the system.
- (2). Make any required external connections such as the display, keyboard, and LAN.
- (3). Plug the appropriate end of the power cord into the power connector on the rear of the system and the plug to an electrical outlet.
- (4). ***Waiting for 3 seconds*** then press the power switch on the front panel of the system once to turn on the system power.
- (5). If necessary, run the BIOS SETUP programs to configure the system.

**Caution:**

*In order to boot up system from USB-CD/DVD drive, please connect USB-CD/DVD drive, turn on computer power, keep on pressing "F11" key, go into BIOS quick boot menu, select "USB-CD ROM", WAIT FOR 20 SECONDS, then press enter, system OS will boot up from USB-CD/DVD drive directly.*



---

## Dimension

---

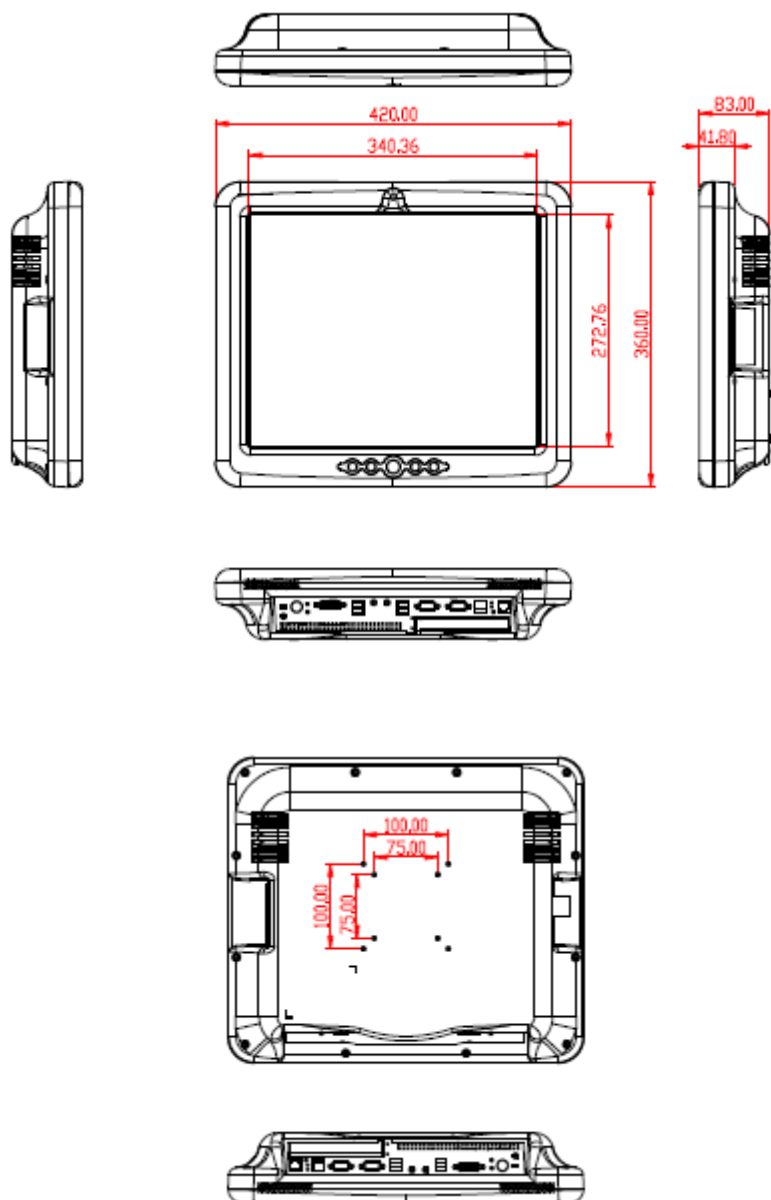

---

# System View

---

## Front View

Webcam (optional)



### Control button at front panel

From left to right:

1. Brightness down
2. Brightness up
3. Power
4. Volume down
5. Volume up

---

## Rear View

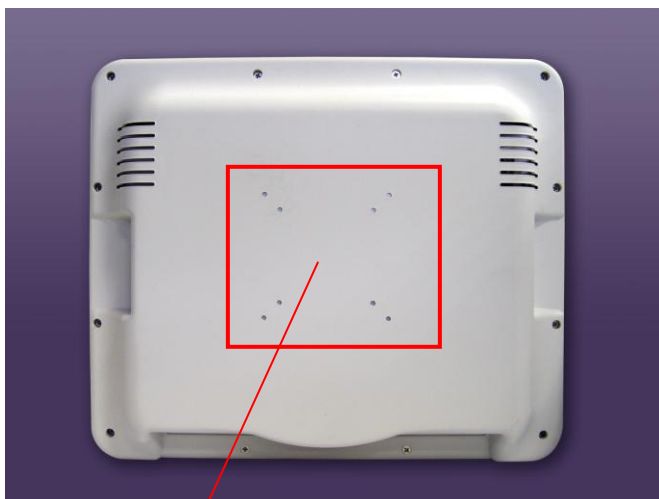

VESA 75/100

---

## I/O parts (WMP-176)

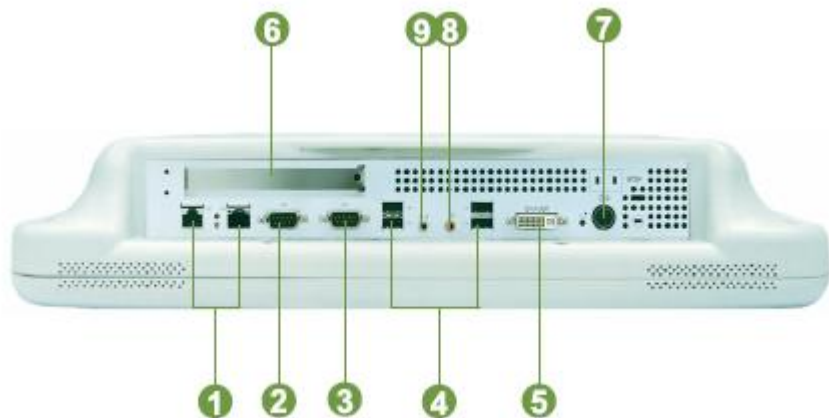

- |                  |                         |
|------------------|-------------------------|
| ❶ Giga Lan x 2   | ❹ Optional PCI-E or PCI |
| ❷ RS 232/422/485 | ❺ Power DC-in           |
| ❸ RS 232         | ❻ MIC                   |
| ❹ USB x 4        | ❼ Line-out              |
| ❺ DVI- I         |                         |

---

## Disconnect Device

---

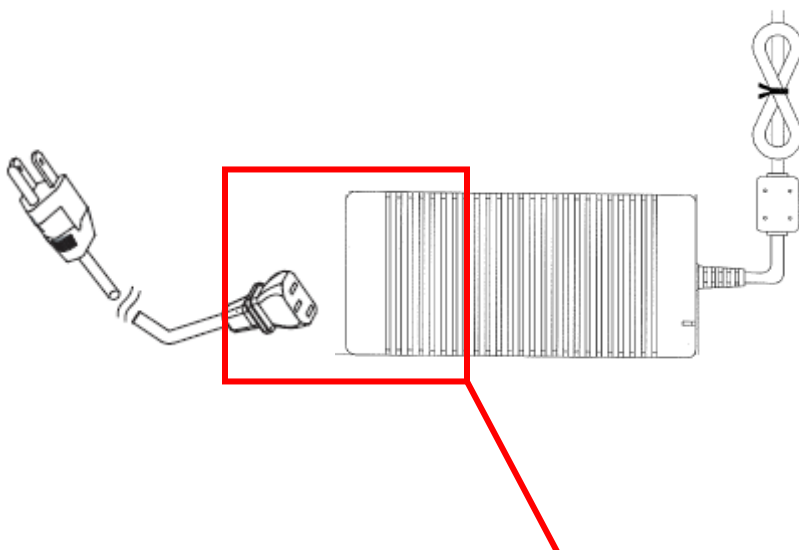

Unplug the power cord from the power adapter jack to disconnect the device.

---

# BIOS Setup

---

---

## BIOS Introduction

The AMI BIOS (Basic Input / Output System) installed in your computer system's ROM supports Intel processors. The BIOS provides critical low-level support for a standard device such as disk drives, serial ports and parallel ports. It also adds virus and password protection as well as special support for detailed fine-tuning of the chipset controlling the entire system.

## BIOS Setup

The AMI BIOS provides a Setup utility program for specifying the system configurations and settings. The BIOS ROM of the system stores the Setup utility. When you turn on the computer, the AMI BIOS is immediately activated. Pressing the <Del> key immediately allows you to enter the Setup utility. If you are a little bit late pressing the <Del> key, POST (Power On Self Test) will continue with its test routines, thus preventing you from invoking the Setup. If you still wish to enter Setup, restart the system by pressing the "Reset" button or simultaneously pressing the <Ctrl>, <Alt> and <Delete> keys. You can also restart by turning the system Off and back On again. The following message will appear on the screen:

Press <DEL> to Enter Setup

In general, you press the arrow keys to highlight items, <Enter> to select, the <PgUp> and <PgDn> keys to change entries, <F1> for help and <Esc> to quit.

When you enter the Setup utility, the Main Menu screen will appear on the screen. The Main Menu allows you to select from various setup functions and exit choices.

# Main

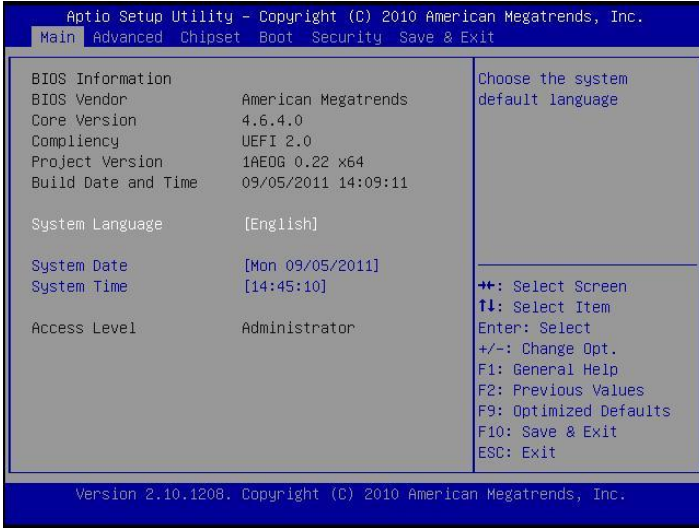

This section provides information on the BIOS information, Memory information, and LAN MAC information

## System Language

Choose the BIOS default language.

## System Date/Time

Set the system date/time. Use the <Tab> key to switch between data/time elements.

## Advanced

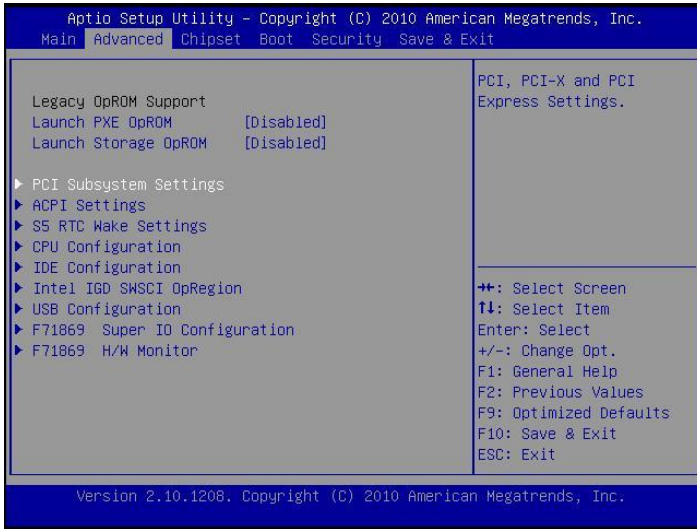

### Launch OpROM Support

#### Launch PXE OpROM

Enables or disables Boot Option for Legacy Network Devices.

#### Launch Storage OpROM

Enables or disables Boot Option for Legacy Mass Storage Devices with Option ROM.

### PCI Subsystem Settings

#### PCI ROM Priority

In Case of multiple Option ROMs (Legacy and EFI Compatible), specifies what PCI Option ROM to launch.

#### PCI Latency Timer

Value to be programmed into PCI Latency Timer Register.

#### VGA Palette Snoop

Enables or disables VGA Palette Registers Snooping.

#### PERR# Generation

Enables or Disables PCI Device to Generate PERR#.

#### SERR# Generation

Enables or Disables PCI Device to Generate SERR#.

#### Relaxed Ordering

Enables or Disables PCI Express Device Relaxed Ordering.

#### Extended Tag

If ENABLED allows Device to use 8-bit Tag field as a requester.

#### No Snoop



---

Enables or Disables PCI Express Device No Snoop option.

**Maximum Payload**

Set Maximum Payload of PCI Express Device or allow System BIOS to select the value

**Maximum Read Request**

Set Maximum Read Request Size of PCI Express Device or allow System BIOS to select the value.

**ASPM Support**

Set the ASPM Level: Force L0 – Force all links to L0 State :  
AUTO – BIOS auto configure : DISABLE – Disables ASPM.

**Extended Synch**

If ENABLED allows generation of Extended Synchronization patterns.

**ACPI Settings**

**Enables ACPI Auto Conf**

Enables or Disables BIOS ACPI Auto Configuration.

**Enable Hibernation**

Enables or Disables System ability to Hibernate (OS/S4 Sleep State). This option may be not effective with some OS.

**ACPI Sleep State**

Select the highest ACPI sleep state the system will enter, when the SUSPEND button is pressed.

**S5 RTC Wake Settings**

**Wake System with Fixed Time**

Enables or disables system wake on alarm event. When enabled, the system will wake on the time specified.

**Wake system with Dynamic Time**

Enables or disables system wake on alarm event. When enabled, the system will wake on the current time+Increase minute(s).

**CPU Configuration**

**Hyper-Threading**

Enabled for Windows XP and Linux (OS optimized for Hyper-Threading Technology) and Disabled for other OS (OS optimized for Hyper-Threading Technology)

**Core-Multi Processing**

Enable or Disable Core-Multi Processing mode.

**Execute Disable Bit**

XD can prevent certain classes of malicious buffer overflow attacks when combined with a supporting OS (Windows Server 2003 SP1, Windows XP SP2, SuSE Linux 9.2, RedHat Enterprise 3 Update 3.)

---

## **Limit CPUID Maximum**

Disabled for Windows XP.

## **IDE Configuration**

### **ATA or IDE Configuration**

Select ATA or IDE configuration.

### **Configure SATA AS**

Select a configuration for SATA controller.

### **HDD Acoustic Power Ma**

Option to enable or disable HDD Acoustic Power Management.

### **DiPM**

Option to enable or disable DiPM

## **Intel IGD SWSCI OpRegion**

### **DVMT Mode Select**

Selects DVMT Mode used by Internal Graphics Device.

### **DVMT/FIXED Memory**

Selects DVMT/FIXED Mode Memory size used by Internal Graphics Device.

### **IGD – Boot Type**

Select the Video Device which will be activated during POST.  
This has no effect if external graphics present.

### **LCD Panel Type**

Select LCD panel used by Internal Graphics Device by selecting the appropriate setup item.

### **Panel Scaling**

Select the LCD panel scaling option used by the Internal Graphics Device.

### **GMCH BLC Control**

Back Light Control Setting

### **BIA Control**

### **Spread Spectrum clock**

>>Hardware: Spread is controlled by chip;

>>Software: Spread is controlled by BIOS.

### **TV1 Standard**

### **TV2 Standard**

### **Active LFP**

Select the Active LFP Configuration.

No LVDS:VBIOS does not enable LVDS.

INT-LVDS:VBIOS enables LVDS driver by Integrated encoder.

SDV0 LVDS:VBIOS enables LVDS driver by SDV0.

## **USB Configuration**

### **Legacy USB Support**

---

Allows USB devices to be used in MS-DOS.

**EHCI Hand-off**

This is a workaround for OSes without EHCI hand-off support. The EHCI ownership change should be claimed by EHCI driver.

**USB transfer time-out**

The time-out value for Control, Bulk, and Interrupt transfers.

**Device reset time-out**

USB mass storage device Start Unit command time-out.

**Device power-up delay**

Maximum time the device will take before it properly reports itself to the HOST Controller.

'Auto' uses default value: for a Root port it is 100 ms, for a Hub port the delay is taken from Hub descriptor.

**F71869 Super IO Configuration**

**Serial Port 0 Configuration**

Set Parameters of Serial Port 0 (COM A).

**Serial Port 1 Configuration**

Set Parameters of Serial Port 1 (COM B).

**F71869 H/W Monitor**

Monitor hardware status

**Second Super IO Configuration**

**Serial Port 1 Configuration**

Set Parameters of Serial Port 1 (COM C).

**Serial Port 2 Configuration**

Set Parameters of Serial Port 2 (COM D).

**Serial Port 3 Configuration**

Set Parameters of Serial Port 3 (COM E).

**Serial Port 4 Configuration**

Set Parameters of Serial Port 4 (COM F).

**Serial Port Console Redirection**

Serial Port Console Redirection.

---

## Chipset



### Host Bridge/South Bridge

This screen provides information on Host Bridge/South Bridge parameters.

## Boot

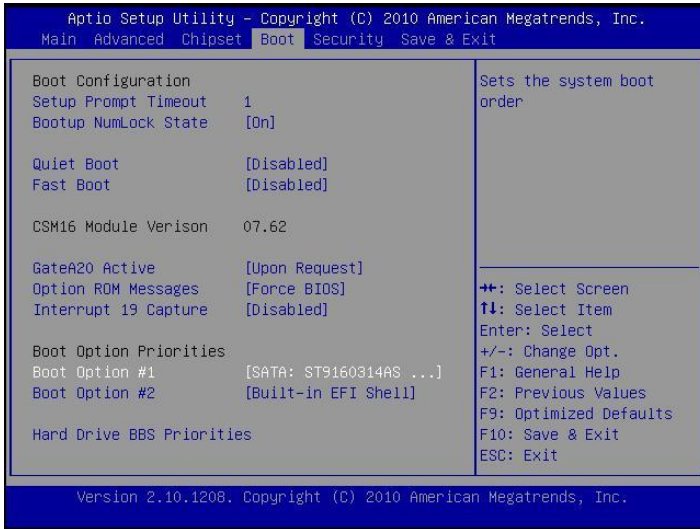

### Setup Prompt Timeout

Number of seconds to wait for setup activation key.  
65535(0xFFFF) means indefinite waiting.

### Bootup Numlock State

Selects the keyboard NumLock state.

### Full Screen LOGO Show

Allows you to determine whether to display the AMI Logo at system startup. **Disabled** displays normal POST message.

### Fast Boot

Enables or disables the quick boot function to speed up the system boot-up process to shorten the waiting time for entering the operating system and to deliver greater efficiency for daily use.

### GateA20 Active

This option is useful when any RT code is executed above 1MB. Upon Request GA20 can be disabled using BIOS services. (Default)

Always Do not allow disabling GA20.

### Option ROM Messages

Sets display made for option ROM.

### Interrupt 19 Capture

Enables or disables Option ROMs to Trap Int 19.

### Boot Option Priorities

Specifies the sequence of loading the operating system from the installed hard drives.

## Security



Enables or disables the security chip. It is recommended that you use this function with the Administrator/User password.

## Save & Exit

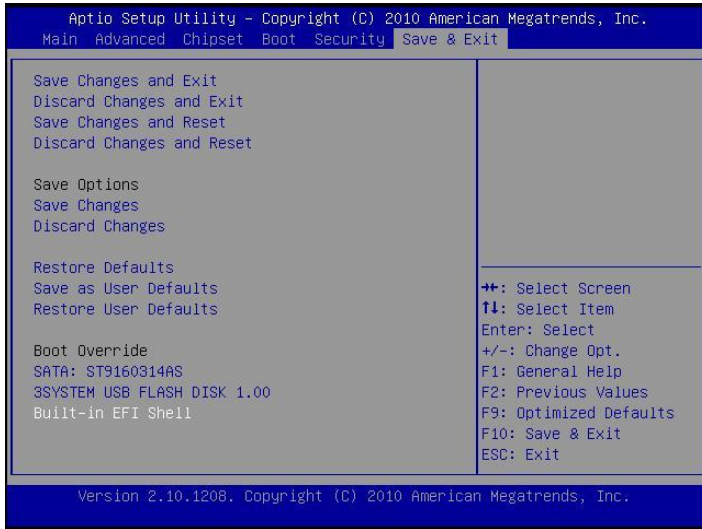

### **Save Changes and Exit**

Exit system setup after saving the changes.

### **Discard Changes and Exit**

Exit system setup without saving any changes.

### **Save Changes and Reset**

Reset the system after saving the changes.

### **Discard Changes and Reset**

Reset system setup without saving the changes.

### **Save Changes**

Save the changes done so far to any of setup options.

### **Discard Changes**

Discard the changes done so far to any of setup options.

### **Restore Defaults**

Restore/load default values for all the setup options.

### **Save as User Defaults**

Save the changes done so far as User Defaults.

### **Restore User Defaults**

Restore the User Defaults to all the setup options.

### **EFIGUI\_FLASH**

Press <Enter> to execute the simple EFI GUI Flash Program.

# Appendix

## A. Jumper settings and Connectors

This appendix gives the definitions and shows the positions of jumpers, headers and connectors. All of the configuration jumpers on WMP-176 are in the proper position.

**Note: Some of jumpers or connectors will be removed base on system configuration.**

### Jumper and Connector Definition Block

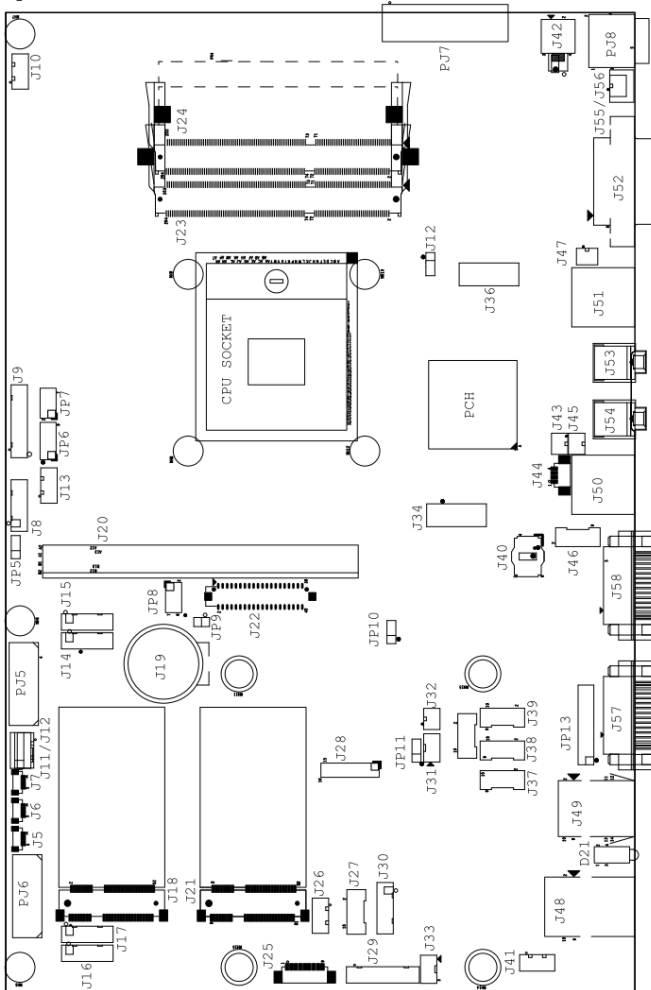



### JP5 –Backlight Adjust

Description	Jumper Setting
<i>analog Inverter</i>	<i>1-2 (default)</i>
PWM Inverter	2-3

### JP6 – Touch Panel Wire Selection

Description	Jumper Setting
4 wire	1-2, 3-4, 5-6, 7-8, 9-10
<i>5 wire</i>	<i>3-4, 5-6, 7-8, 9-10 (default)</i>
8 wire	1-2

### JP7 – Touch Panel Type Selection

Description	Jumper Setting
<i>3M type</i>	<i>1-2, 3-4 (default)</i>
ELO type	5-6,7-8

### JP8– Panel Power Selection

Description	Jumper Setting
<i>+5VS (for 17"/19"/21.5")</i>	<i>1-2,3-4 (default)</i>
+3.3VS (for 10"/12"/15")	5-6,7-8

### JP9 –TPM Settings

Description	Jumper Setting
Clear ME RTC registers	1-2
<i>Keep ME RTC registers</i>	<i>OPEN (default)</i>

**JP10 – CMOS Clear**

<b>Description</b>	<b>Jumper Setting</b>
<i>Normal Open</i>	<i>1-2 (default)</i>
CMOS Clear	2-3

**JP11 – Thermal sensor**

<b>Description</b>	<b>Jumper Setting</b>
<i>Auto detect</i>	<i>1-2(default)</i>
always 25 °C	2-3
always -40 °C	NC

**JP12 – SATA or SATA DOM Selection**

<b>Description</b>	<b>Jumper Setting</b>
SATA DOM	1-2 ---power +5V
<i>SATA</i>	<i>2-3(default)--- GND</i>

**JP13 – COM1 Function Selection**

<b>Description</b>	<b>Jumper Setting</b>
<i>RS-232</i>	<i>5-6, 9-11, 10-12, 15-17, 16-18(default)</i>
RS-422	3-4, 7-9, 8-10, 13-15, 14-16, 21-22
RS-485	1-2, 7-9, 8-10, 19-20

## Connector Definition

### PJ5 – HDD Power Connector

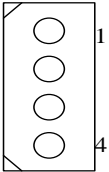

Pin #	Signal Description
1	+12V
2	Ground
3	Ground
4	+5V

### PJ6 – HDD Power Connector

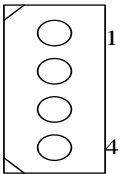

Pin #	Signal Description
1	+12V
2	Ground
3	Ground
4	+5V

### PJ7 – Battery Connector

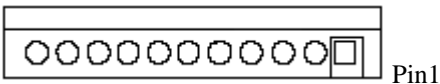

Pin #	Signal Description
1	BATT+

2	BATT+
3	BATT+
4	BAT_T
5	BAT_C
6	BAT_D
7	BATT_EN#
8	BATT-
9	BATT-
10	BATT-

**PJ8 – Power Jack Connector**

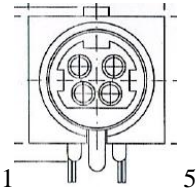

Pin #	Signal Description
1	DC In
2	DC In
3	Ground
4	Ground
5	Ground

**J5,J6,J7 – Internal USB +3.3V Interface**

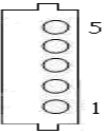

Pin #	Signal Description
1	+3.3VS
2	Data -
3	Data +
4	Ground
5	Ground

## J8 – LCD Inverter Interface

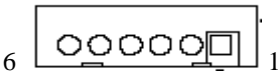

Pin #	Signal Description
1	+12V
2	+12V
3	Backlight Adjust
4	Backlight Enable
5	Ground
6	Ground

## J9 –Resistor Touch Panel Interface

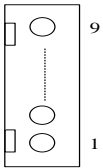

Pin #	Signal Description		
	8-wire	4-wire	5-wire
1	UL(X+)	UL(X+)	UL(X+)
2	UR(Y+)	UR(Y+)	UR(Y+)
3	N/A	N/A	PRCBE
4	LR(X-)	LR(X-)	LR(X-)
5	LL(Y-)	LL(Y-)	LL(Y-)
6	X+_DRIVE	N/A	N/A
7	Y+_DRIVE	N/A	N/A
8	X-_DRIVE	N/A	N/A
9	Y-_DRIVE	N/A	N/A

## J10,J11/J12 –PWM CPU FAN, SYSTEM FAN



Pin #	Signal Description		
	J10(SYSTEM)	J11(CPU) 2.54mm	J12(CPU) 2.0mm
1	AUX PWM	CPU PWM	SYS PWM
2	AUX RPM	CPU RPM	SYS RPM
3	VAUXFAN	VCPUXFAN	VSYSXFAN
4	GND	GND	GND

**J13 –F/W IC-EETI control**



Pin #	Signal Description
1	+3.3V_TP
2	C2CK
3	C2D
4	Ground

**J14, J15 – Internal USB 5V Interface**

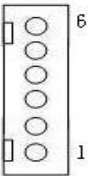

Pin #	Signal Description
1	+5VSB

2	+5VSB
3	Data -
4	Data +
5	Ground
6	Ground

**J16, J17 – Internal USB 5V (QM67 only Support)**



Pin #	Signal Description
1	+5VSB
2	+5VSB
3	Data -
4	Data +
5	Ground
6	Ground

**J18, J21 – mini PCI Express Socket**

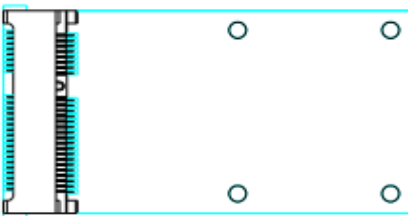

Pin #	Signal Description	Pin #	Signal Description
1	WAKE#	2	+3.3VSB
3	Reserved	4	GND
5	Reserved	6	+1.5VS
7	CLKREQ#	8	Reserved
9	GND	10	Reserved
11	REFCLK-	12	Reserved
13	REFCLK+	14	Reserved
15	GND	16	Reserved
17	Reserved	18	GND
19	Reserved	20	Reserved
21	GND	22	PERST#
23	PERn0	24	+3.3VSB
25	PERp0	26	GND
27	GND	28	+1.5VS
29	GND	30	SMB_CLK
31	PETn0	32	SMB_DATA
33	PETp0	34	GND
35	GND	36	USB_D-
37	GND	38	USB_D+
39	+3.3VSB	40	GND
41	+3.3VSB	42	Reserved
43	GND	44	Reserved
45	CL_CLK	46	Reserved
47	CL_DATA	48	+1.5VS
49	Controller Link RST#	50	GND
51	Reserved	52	+3.3VSB

### J19 – Battery Socket

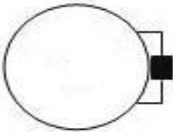

Pin #	Signal Description
1	RTC +3.3V
2	GND

### J20 –Standard PCIE X16 Slot Interface





Pin #	Side B	Side A	Pin #	Side B	Side A
1	+12V	PRSNT1#	42	PETn6	GND
2	+12V	+12V	43	GND	PERp6
3	+12V	+12V	44	GND	PERn6
4	GND	GND	45	PETp7	GND
5	SMCLK	PCIE_TXN6	46	PETn7	GND
6	SMDAT	PCIE_TXP6	47	GND	PERp7
7	GND	PCIE_RXN6	48	Reserved	PERn7
8	+3.3V	PCIE_RXP6	49	GND	GND
9	Reserved	+3.3V	50	PETp8	Reserved
10	+3.3V	+3.3V	51	PETn8	GND
11	WAKE#	PERST#	52	GND	PERp8
12	Reserved	GND	53	GND	PERn8
13	GND	PCIEx16_CLK+	54	PETp9	GND
14	PETp0	PCIEx16_CLK-	55	PETn9	GND
15	PETn0	GND	56	GND	PERp9
16	GND	PERp0	57	GND	PERn9
17	Reserved	PERn0	58	PETp10	GND
18	GND	GND	59	PETn10	GND
19	PETp1	Reserved	60	GND	PERp10
20	PETn1	GND	61	GND	PERn10
21	GND	PERp1	62	PETp11	GND
22	GND	PERn1	63	PETn11	GND
23	PETp2	GND	64	GND	PERp11
24	PETn2	GND	65	GND	PERn11
25	GND	PERp2	66	PETp12	GND
26	GND	PERn2	67	PETn12	GND
27	PETp3	GND	68	GND	PERp12
28	PETn3	GND	69	GND	PERn12
29	GND	PERp3	70	PETp13	GND
30	PCIEx1_CLK+	PERn3	71	PETn13	GND
31	PCIEx1_CLK-	GND	72	GND	PERp13
32	GND	Reserved	73	GND	PERn13
33	PETp4	Reserved	74	PETp14	GND
34	PETn4	GND	75	PETn14	GND
35	GND	PERp4	76	GND	PERp14
36	GND	PERn4	77	GND	PERn14

37	PETp5	GND	78	PETp15	GND
38	PETn5	GND	79	PETn15	GND
39	GND	PERp5	80	GND	PERp15
40	GND	PERn5	81	Reserved	PERn15
41	PETp6	GND	82	<b>PCICLK_33M</b>	GND

**J22 – LVDS Interface**

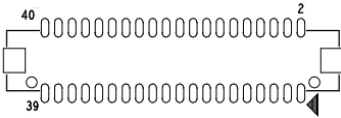

Pin #	Signal Description	Pin #	Signal Description
1	+LCD (+5V/ +3.3V)	2	+LCD (+5V/ +3.3V)
3	+LCD (+5V/ +3.3V)	4	+LCD (+5V/ +3.3V)
5	Ground	6	Ground
7	Ground	8	Ground
9	A_RxIn0-	10	B_RxIn0-
11	A_RxIn0+	12	B_RxIn0+
13	Ground	14	Ground
15	A_RxIn1-	16	B_RxIn1-
17	A_RxIn1+	18	B_RxIn1+
19	Ground	20	Ground
21	A_RxIn2-	22	B_RxIn2-
23	A_RxIn2+	24	B_RxIn2+
25	Ground	26	Ground
27	A_CKIN-	28	B_CKIN-
29	A_CKIN+	30	B_CKIN+
31	Ground	32	Ground
33	A_RxIn3-	34	B_RxIn3-
35	A_RxIn3+	36	B_RxIn3+
37	Ground	38	Ground
39	Ground	40	Ground

**J23,J24 – DDR3 SO-DIMM Interface**

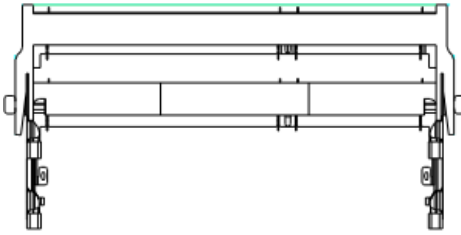

**J23→ H9.2 Near CPU**  
**J24→ H5.2 Near External**

Pin	Symbol	Pin	Symbol	Pin	Symbol	Pin	Symbol	Pin	Symbol	Pin	Symbol
1	VREFDQ	69	DQ27	137	DQS4	2	VSS	70	DQ31	138	VSS
3	VSS	71	VSS	139	VSS	4	DQ4	72	VSS	140	DQ38
5	DQ0	73	CKE0	141	DQ34	6	DQ5	74	NC	142	DQ39
7	DQ1	75	VDD	143	DQ35	8	VSS	76	VDD	144	VSS
9	VSS	77	NC	145	VSS	10	DQS0#	78	NC	146	DQ44
11	DM0	79	BA2	147	DQ40	12	DQS0	80	NF/A14	148	DQ45
13	VSS	81	VDD	149	DQ41	14	VSS	82	VDD	150	VSS
15	DQ2	83	A12	151	VSS	16	DQ6	84	A11	152	DQS5#
17	DQ3	85	A9	153	DM5	18	DQ7	86	A7	154	DQ55
19	VSS	87	VDD	155	VSS	20	VSS	88	VDD	156	VSS
21	DQ8	89	A8	157	DQ42	22	DQ12	90	A6	158	DQ46
23	DQ9	91	A5	159	DQ43	24	DQ13	92	A4	160	DQ47
25	VSS	93	VDD	161	VSS	26	VSS	94	VDD	162	VSS
27	DQS1#	95	A3	163	DQ48	28	DM1	96	A2	164	DQ52
29	DQS1	97	A1	165	DQ49	30	RESET#	98	A0	166	DQ53
31	VSS	99	VDD	167	VSS	32	VSS	100	VDD	168	VSS
33	DQ10	101	CK0	169	DQS6#	34	DQ14	102	CK1	170	DM6
35	DQ11	103	CK0#	171	DQS6	36	DQ15	104	CK1#	172	VSS
37	VSS	105	VDD	173	VSS	38	VSS	106	VDD	174	DQ54
39	DQ16	107	A10	175	DQ50	40	DQ20	108	BA1	176	DQ55
41	DQ17	109	BA0	177	DQ51	42	DQ21	110	RAS#	178	VSS
43	VSS	111	VDD	179	VSS	44	VSS	112	VDD	180	DQ60
45	DQS2#	113	WE#	181	DQ56	46	DM2	114	S0#	182	DQ61
47	DQS2	115	CAS#	183	DQ57	48	VSS	116	ODT0	184	VSS
49	VSS	117	VDD	185	VSS	50	DQ22	118	VDD	186	DQS7#
51	DQ18	119	A13	187	DM7	52	DQ23	120	NC	188	DQS7
53	DQ19	121	NC	189	VSS	54	VSS	122	NC	190	VSS
55	VSS	123	VDD	191	DQ58	56	DQ28	124	VDD	192	DQ62
57	DQ24	125	NC	193	DQ59	58	DQ29	126	VREFCA	194	DQ63
59	DQ25	127	VSS	195	VSS	60	VSS	128	VSS	196	VSS
61	VSS	129	DQ32	197	SA0	62	DQ3#	130	DQ36	198	EVENT#
63	DM3	131	DQ33	199	VDDSPD	64	DQ3	132	DQ37	200	SDA
65	VSS	133	VSS	201	SA1	66	VSS	134	VSS	202	SCL
67	DQ26	135	DQS4#	203	VTT	68	DQ30	136	DM4	204	VTT

**J25 – CAP Front Bezel Button Connector ( For WMP-176)**

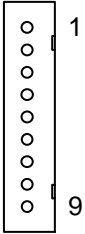

Pin #	Signal Description
1	+3.3V
2	+3.3V
3	KP_SCL
4	KP_SDA
5	HEATER_LED#
6	KP_INT#
7	SATA_LED#
8	Ground
9	Ground

**J26 – SDP (EC Simple Debug Port)**

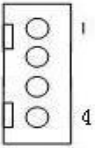

Pin #	Signal Description
1	+5V
2	P80_DAT
3	P80_CLK
4	Ground

**J27 – EC JTAG**

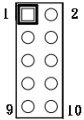

Pin #	Signal Description	Pin #	Signal Description
1	EC_TRST#	2	+3.3V
3	EC_TMS	4	EC_RDY#
5	EC_TDI	6	GND
7	EC_TCK	8	GND
9	EC_TDO	10	GND

**J28 –TPM / ID-394**

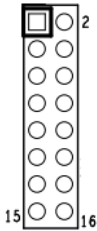

Pin #	Signal Description	Pin #	Signal Description
1	LPC AD0	2	PCI reset
3	LPC AD1	4	SERIRQ
5	LPC AD2	6	+3.3V
7	LPC AD3	8	+5V
9	LPC Frame	10	PCI CLKRUN
11	Debug CLK	12	SMB CLK
13	GND	14	SMB DATA
15	SUS_STAT#	16	+3.3V

**J29 – Front Bezel Button Connector**

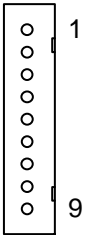

Pin #	Signal Description
1	Power Button
2	+3.3V
3	Sound Volume Up
4	Sound Volume Down
5	Ground
6	LCD BackLight Up
7	LCD BackLight Down
8	Touch Screen Forbid
9	LCD BackLight ON/OFF

### **J30 – PS2 KB/MS connector**

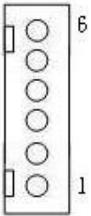

Pin #	Signal Description
1	Keyboard data
2	Mouse data
3	GND
4	5V
5	Keyboard clock
6	Mouse clock

### **J31 – Light Sensor Connector (For Outdoor)**



Pin #	Signal Description
1	Light Sensor
2	NC
3	+3.3V

### **J32 – EC Reset**

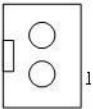

Pin #	Signal Description
1	VCC_POR#
2	GND

### **J33 – HEATER, CLEAR ME LED INDICATE**

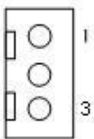

Pin #	Signal Description
1	+3.3V_UC
2	HEATER_LED#
3	KEYLOCK_LED#

### **J34, J36 – Standard SATA Interface**



Pin #	Signal Description
1	Ground
2	Tx+
3	Tx-
4	Ground
5	Rx-
6	Rx+
7	Ground

**J35 – RS-232 TTL Connector**

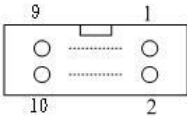

Pin #	Signal Description	Pin #	Signal Description
1	DCD#	2	DSR#
3	SIN	4	RTS#
5	SOUT	6	CTS#
7	DTR#	8	RI#
9	GND	10	+5VS

**J46, J37, J38, J39 – COM3, COM4, COM5, COM6 Serial Port**

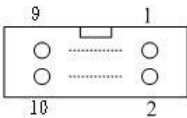

Pin #	Signal Description	Pin #	Signal Description
1	232_DCD	2	232_DSR
3	232_SIN	4	232_RTS
5	232_SOUT	6	232_CTS



7	232_DTR	8	232_RI
9	GND	10	+5VS

**J40 – BIOS SOCKET**



Pin1

Pin #	Signal Description	Pin #	Signal Description
1	CS#	5	VDD
2	SO	6	HOLD#
3	WP#	7	SCK
4	VSS	8	SI

**J41 – POWER & HDD LED (For WMP-176/196 )**

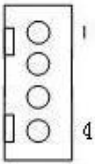

Pin #	Signal Description
1	SATA LED
2	+3.3V
3	+3.3V
4	Power LED

**J42 – ATX 12V Connect (For Heater Power)**

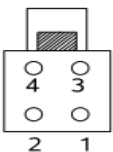

Pin #	Signal Description
1	+12V
2	+12V
3	Ground
4	Ground

**J43 , J45 – Passive Speaker Connect**



J43(Right Channel)		J45(Left Channel)	
Pin #	Signal Description	Pin #	Signal Description
1	AMP. Out +	1	AMP. Out +
2	AMP. Out -	2	AMP Out -

**J44 – Handset Connect**

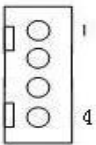

Pin #	Signal Description
1	HOOK_ON#
2	Handset speaker
3	Handset MIC
4	GND

## **J47 – Power Switch connect**

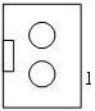

<b>Pin #</b>	<b>Signal Description</b>
1	Power ON
2	GND

## **J48, J49 – Ethernet Port**

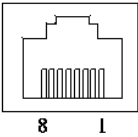

<b>Pin #</b>	<b>Signal Description</b>
1	Data0+
2	Data0-
3	Data1+
4	Data2+
5	Data2-
6	Data1-
7	Data3+
8	Data3-

## **J50, J51 – USB1/2,3/4 Port**

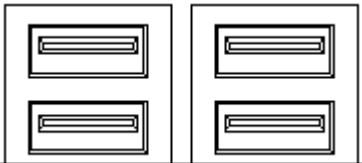

<b>Pin #</b>	<b>Signal Description</b>
1	+5V
2	Data-

3	Data+
4	GND

### J52 – DVI-I Interface

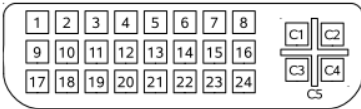

Pin #	Signal Description	Pin #	Signal Description
1	TMDS Data2-	2	TMDS Data2+
3	TMDS Data2 shield	4	NC
5	NC	6	DDC Clock
7	DDC Data	8	Analog VSYNC
9	TMDS Data1-	10	TMDS Data1+
11	TMDS Data1 Shield	12	NC
13	NC	14	+5V
15	GND	16	Hot Plug Detect
17	TMDS Data0-	18	TMDS Data0+
19	TMDS Data0 Shield	20	NC
21	NC	22	TMDS Clock Shield
23	TMDS Clock+	24	TMDS Clock-
C1	Analog Red	C2	Analog Green
C3	Analog Blue	C4	Analog HSYNC
C5	GND	C6	GND

### J53, J54 – Audio Connector



Pin #	Signal Description
J53	Microphone (stereo) Pink
J54	Line Out (stereo) Green

### J55 – Reset connector

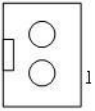

Pin #	Signal Description
1	SYS_RESET#
2	GND

### J56 – Reset Button

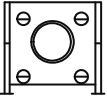

Pin #	Signal Description
1	SYS_RESET#
2	GND

### J57 – COM1 Connector

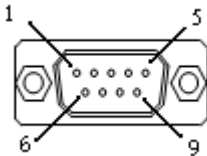

Pin #	Signal Description		
	RS-232	RS-422	RS-485
1	Carrier Detect	Transmit Data -	Transmit Data -
2	Receive Data	Transmit Data +	Transmit Data +
3	Transmit Data	Receive Data +	NC
4	Data Terminal Ready	Receive Data -	NC
5	Ground	NC	NC
6	Data Set Ready	NC	NC
7	Request to Send	NC	NC

## APPENDIX

8	Clear to Send	NC	NC
9	Ring Indicator	NC	NC

### J58 – COM2 Connector

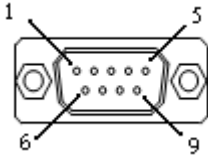

Pin #	Signal Description	Pin #	Signal Description
1	232_DCD	2	232_SIN
3	232_SOUT	4	232_DTR
5	GND	6	232_DSR
7	232_RTS	8	232_CTS
9	232_RI	10	Not Used

## B. VESA Mounting (optional kit)

The WMP-176 also provides standard VESA mounting to help system integrators conveniently integrate the medical panel PC into their system. Never use any other mounting brackets except those provided by Wincomm to prevent the unreliable fixing of WMP-176. VESA mount installation should be carried out by a professional technician. Please contact the service technician or your retailer if you need this service.

### Installation instructions follow:

1. The wall-mounting attachment is comprised of two parts: one back bracket, and one mounting bracket.
2. First attach the back bracket to the rear cover of the WMP-176, securing it in place with four of the Phillips-head screws provided.
3. Attach the mounting bracket to the wall or another flat surface. The back bracket slides vertically from the top into the mounting bracket. It can be secured to the mounting bracket by screwing four of the Phillips-head screws provided through the corresponding holes at the tops of the mounting bracket.

### Warning:

Be sure to secure the screws of the mounting bracket tightly. Injuries could result if the WMP-176 isn't properly secured to the mounting bracket.

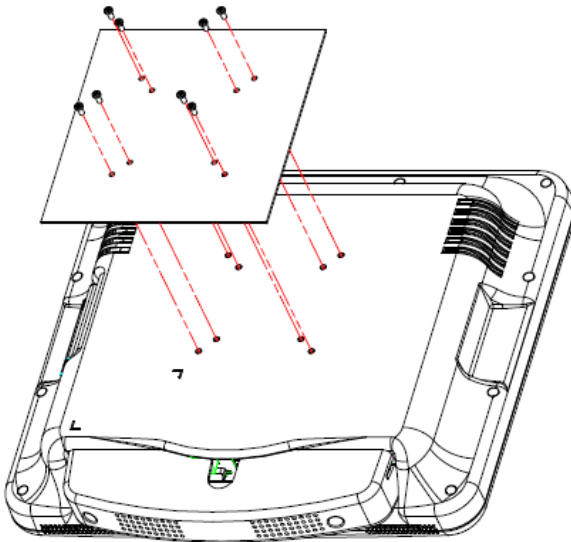

Screws: M4 x 10mm

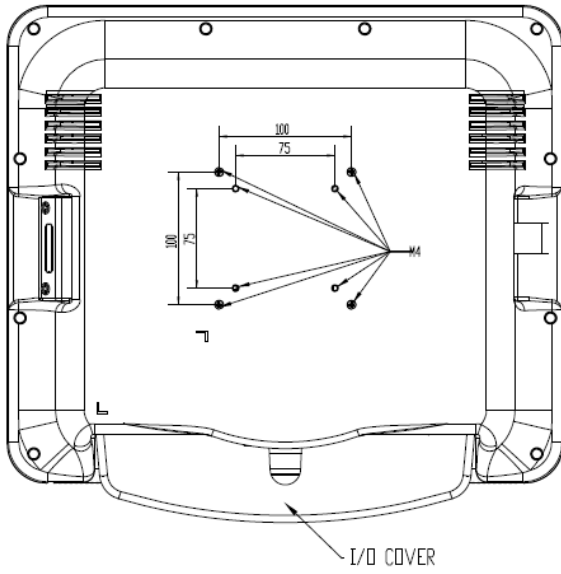

**Figure B.1: VESA mounting dimension diagram (75 x 75 mm, 100 x 100 mm)**



**C. Battery Pack Specifications (optional kit)**

Battery Manufacturer	GETAC TECHNOLOGY CORP.
Battery Model	BP-WMP001-22/1900A
Battery Type	Li-ion 2S2P
Minimum Capacity	3800 mAh
Nominal Voltage	7.3 V
Max. Charge Voltage	8.4 V
Cut Off Voltage	6.0 V
Backup	100 W/ 10 min

## **D. How to disable battery when system hang up on WMP-176**

1. When system hang up ,press power button 4 seconds to turn off system . If you can't power on system by power button. Please follow below step to reset system.
2. Press volume up key 10 seconds, then power LED will turn on then turn off



3. Plug in AC power cord again, press power button then you can power on system.

## **E. Scrap Computer Recycling**

If the computer equipments need the maintenance or are beyond repair, we strongly recommended that you should inform us as soon as possible for the suitable solution. For the computers that are no longer useful or work well, please contact with worldwide distributors for recycling.

The worldwide distributors show on the following website:

<http://www.wincomm.com.tw/contact.aspx>

### **Note:**

Follow the national requirement to dispose unit