

Industrial 8-port Ethernet Switch
User's Manual

Content

1. Introduction.....	2
1-1. Features.....	2
1-2. Packing List.....	3
2. Hardware Description.....	4
2-1. Dimensions.....	4
2-2. Front Panel.....	4
2-3. Bottom View.....	5
2-4. LED Indicators.....	6
2-5. Ports.....	7
3. Mounting Installation.....	8
DIN-Rail Mounting.....	8
4. Hardware Installation.....	9
4-1. Wiring the DC Power Inputs.....	10
4-2. Wiring the Alarm Relay.....	11
4-3. Wiring Earth Grounding.....	11
4-4. Enabled the Event Alarm Function.....	12
4-5. Cabling.....	13
4-6. System Power-On and Testing.....	14
5. Packet forwarding ability.....	17
5-1. Broadcast Control.....	17
5-2. Quality of Service.....	17
6. Trouble shooting.....	19
7. Technical Specifications.....	20

1. Introduction

The 8-port compact Fast Ethernet switch is equipped with 2.0 Gbps Packet Switch engine as particular packet forwarding and filtering mechanism to fulfill industrial communications on the filed site. It provides the graceful packet forwarding ability to handle 64~1552 packet size into 2 priority queues which complies with quality of service for the best data forwarding performance.

In addition, for the best network performance both of broadcast storm filtering and flow control functions can ensure your data traffic deliver to destination without traffic congestion. To avoid interference as well as to extend your network coverage, this is adapted to 2 100Mbps fiber ports with multi-mode or single-mode transceiver in order to achieve stable far-end transmissions.

To survive under hazard environments, it is equipped with 2 redundant power inputs, as the wide range input avoiding any power interruption and also operating between -25C~70C temperature range. For the easy maintenance purpose, the switch has an alarm-relay for the port link event and the power event to give an alarm to the service engineer on the filed site. It will deliver you superiority and reliable performance on your filed site applications.

This session introduces the following information:

- 1-1. Features
- 1-2. Packing list

1-1. Features

- ◎ 8 x 10/100TX ports
- ◎ Compact size with full power redundancy
- ◎ Supports store-and-Forward switching architecture
- ◎ QoS for packet forwarding precedence
- ◎ Broadcast storm packet filtering
- ◎ Port and power event alarm
- ◎ IP-31 aluminum alloy case
 - ◎ DIN rail and wall mount
- ◎ Dual power input DC12~48V
- ◎ Compliance with IEEE Hi-Pot Testing

1-2. Packing List

The Industrial 8-port Fast Ethernet Switch is packaged with the following items:

- ⊙ Product
- ⊙ CD : User Manual



CD User's Manual

Contact your sales representative if any item is missing or damaged.

2. Hardware Description

This session will introduce the hardware information as following:

- 2-1. Dimensions
- 2-2. Front Panel
- 2-3. Bottom View
- 2-4. LEDs of system and port
- 2-5. Connectors

2-1. Dimensions

The dimension of 8-port Industrial Fast Ethernet Rail Switch is **120 mm (H) x 55 mm (W) x 108 mm (D)**. The following is the drawing of detail mechanical design:

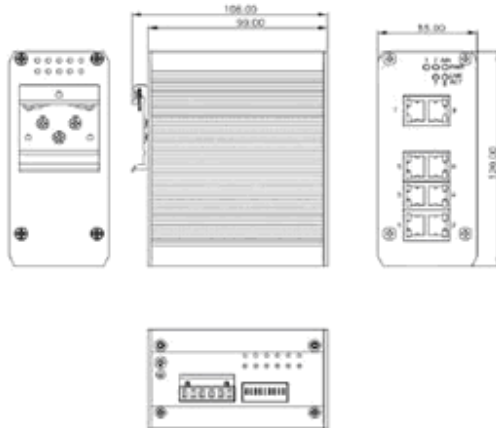

2-2. Front Panel

The Front Panel of the Industrial 8-port Fast Ethernet Switch is shown in Figure A.

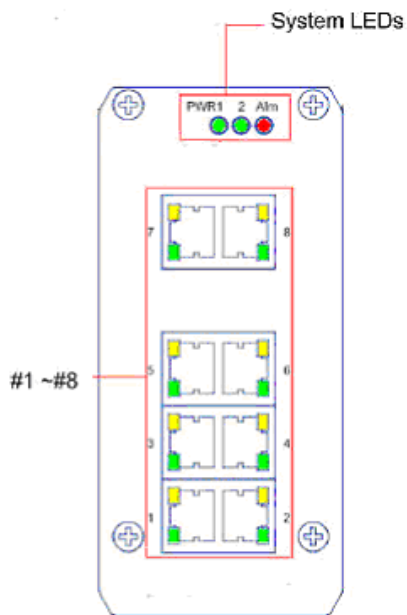

Figure A. Front Panel

2-3. Bottom View

The bottom view of the Industrial 8-port Ethernet Switch consists of one 6-pin removable terminal block connector for two DC power inputs and event alarm output. There is one 9-pin DIP SWITCH on the bottom for alarm control of port or power event selection.

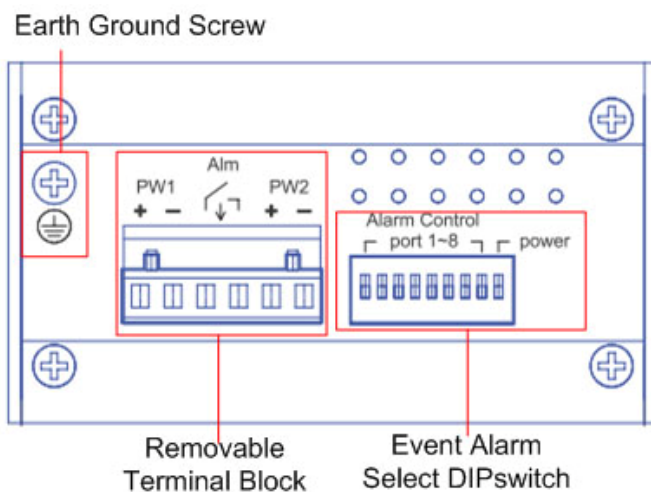

Figure B. Bottom view

2-4. LED Indicators

There are some system diagnostic LEDs and Ethernet Port LEDs located on the front panel of Industrial 8-port Ethernet Switch. These LED indicators provide administrators with real-time system status. Table-1 gives the descriptions of the function of each LED indicator.

LED	Status	Description
PWR1	Green on	Power is on.
	Off	No power is being supplied.
PWR2	Green on	Power is on.
	Off	No power is being supplied.
Alm	Red on	Port link down or power failure event occurred.
	Off	No event.
Port 1~8	Link (Green on)	A network device is detected and link up.
	Activity (Green blinks)	The port is transmitting or receiving packets from the TX device.
	Speed (Yellow on/ 100Mbps)	A network device is detected and link on 100Mbps.
	Speed (Yellow off)	A network device is detected and link on 10Mbps.

Table-1

2-5. Ports

RJ-45 ports (Auto MDI/MDIX): 8 x 10/100 Mbps ports (auto-sensing RJ-45) for 10Base-T /100Base-TX device connection.

The RJ-45 ports will auto-detect 10Base-T and 100Base-TX connections. Auto MDI/MDIX function allows users to connect another switch or workstation without the straight through cable or the crossover cable. See Figure C and C-1 for the schematic diagram of straight through cable and crossover cable.

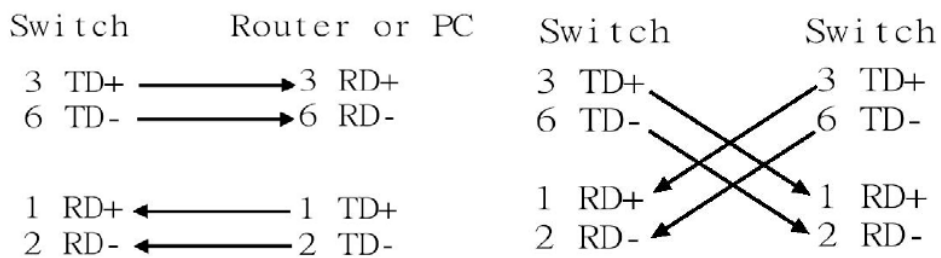

Figure C Straight Through Cabling Schematic

Figure C-1 Cross Over Cabling Schematic

All of the RJ-45 ports of the switch support auto-MDI/MDI-X function. When you use an Ethernet cable to connect other devices, such as computers, switches or hubs, pin 1, 2, 3, and 6 of the 8-pin RJ45 connector are used to communicate with the connected devices. Pin1, 2, 3, and 6's signals are converted by the MDI-X function shown in Table -2.

Pin MDI-X	Signals	MDI Signals
1	RD+	TD+
2	RD-	TD-
3	TD+	RD+
6	TD-	RD-

Table-2

3. Mounting Installation

DIN-Rail Mounting

The DIN-Rail clip is already attached on the rear side of the switch supports EN 50022 standard DIN Rail, in the following diagram includes the dimension of EN 55022 DIN Rail.

Follow the steps below to mount the switch on the DIN-Rail track.

1. Insert the upper end of the DIN-Rail clip into the back of the DIN-Rail track from its upper side
2. Lightly push the bottom of the DIN-Rail clip into the track.
3. Check if the DIN-Rail clip is tightly attached to the track.
4. To remove the switch from the track, reverse the steps above.

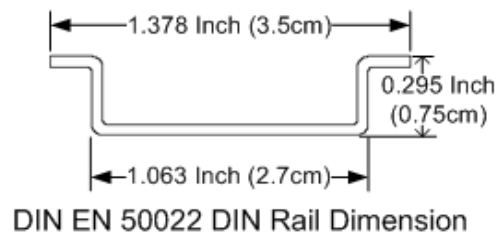
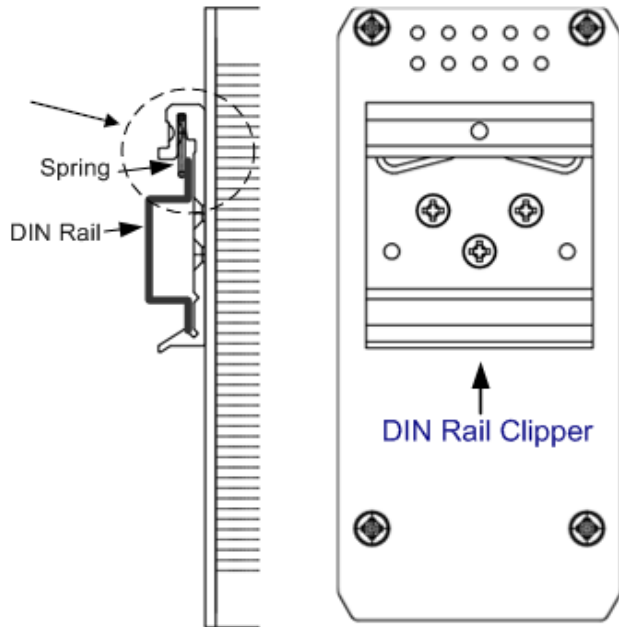

4. Hardware Installation

The following figure illustrates a typical application of the switch in field site. It includes Enterprise communication backbone network, Factory communication, field site communication and field site control layers. The control equipments access and report production information through the switch and uplink to factory communication level by fiber or copper which with network redundancy.

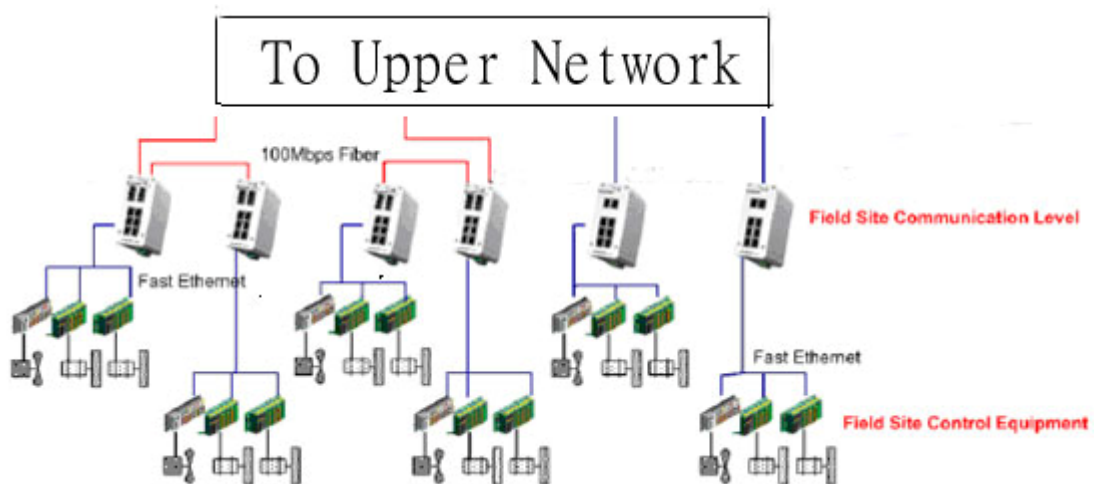

This session will introduce the hardware installation, includes:

- 4-1. Wiring the DC Power Inputs
- 4-2. Wiring the Relay Alarm
- 4-3. Wiring Earth Grounding
- 4-4. Enable Alarm Relay Function
- 4-5. Cabling
- 4-6. System Power-On and Testing

4-1. Wiring the DC Power Inputs

Follow the steps below to wire the switch dual DC power inputs.
[Note] The suitable electric wire ranges is from 12 to 24 AWG.

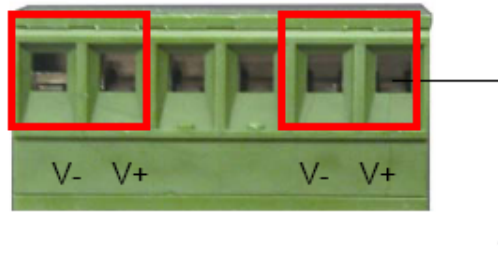

1. Insert the positive and negative wires into the V+ and V- contacts respectively of the terminal block connector

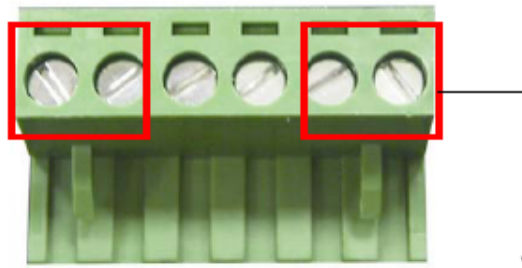

2. Tighten the wire-clamp screws to prevent the DC wires from being loosened.

Before install power, be sure the power supply module is compliance with UL certificated and the power system is shut down to avoid any damage.
 About the wiring please refer following diagram.

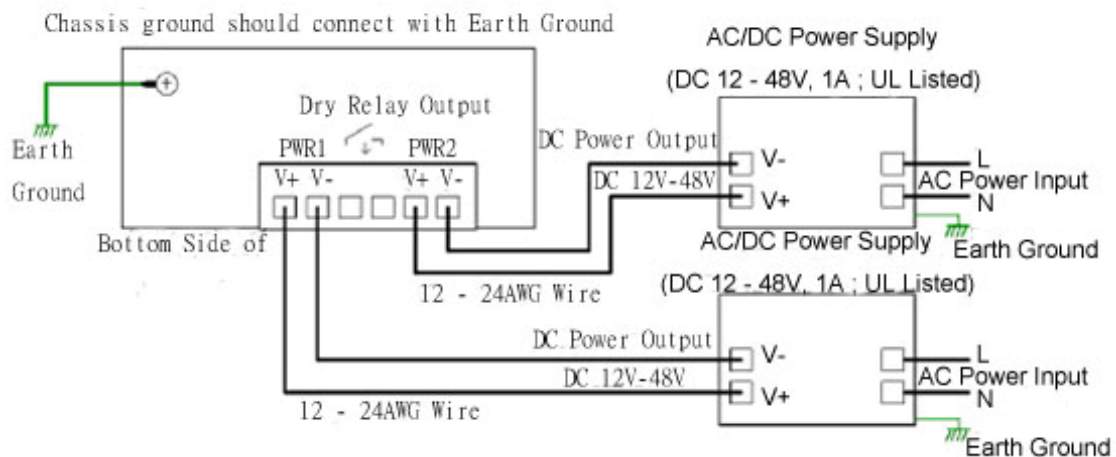

4-2. Wiring the Alarm Relay

The switch provides one dry relay output for power or port link event. The alarm relay default is “open” and form a close circuit when the even is occurred. The relay conductor ability is 24W. When it connects with a DC 24V power source, the maximum current is 1A. The following diagram shows how to create an alarm circuit.

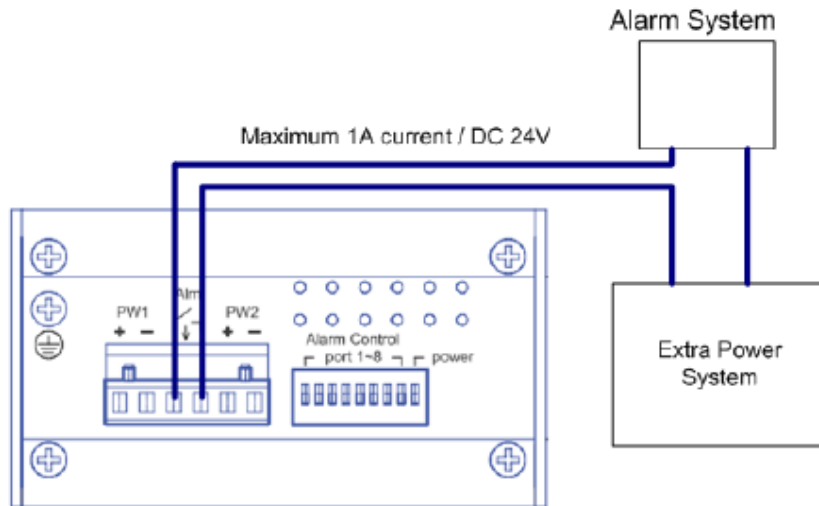

4-3. Wiring Earth Grounding

In the real fields, there are a lot of automatic devices, such as AC motors, electric welding machine and power generator. Those devices will generate electromagnetic and disturb communications. To prevent those noises, the switch should be well earthed. The following diagram shows how to create a connection.

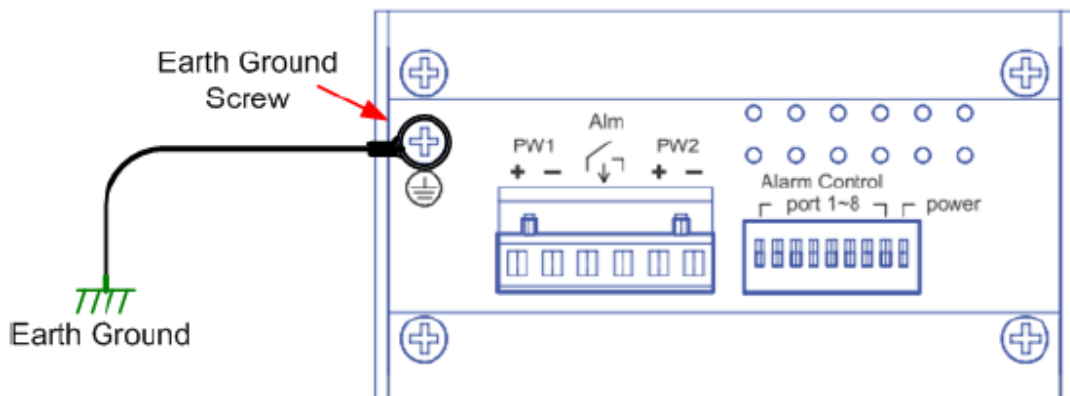

Warning: Do not connect to AC line - Natural

4-4. Enabled the Event Alarm Function

This session will introduce how to configure and enable the event alarm to alert maintenance engineer once the system event is occurred. The switch is equipped with one dry relay output for port link fails or power fails. The feature is controlled by digital control circuits. It effects immediately without system reset when DIP SWITCH is changed.

On the bottom side of the switch, there is one 9-Pin DIP SWITCH for alarm control. By inserting the port and power wiring to set up the alarm, the DIP SWITCH of the intended Alarm is switched to "ON". The relay output will form a short circuit if the alarm occurred.

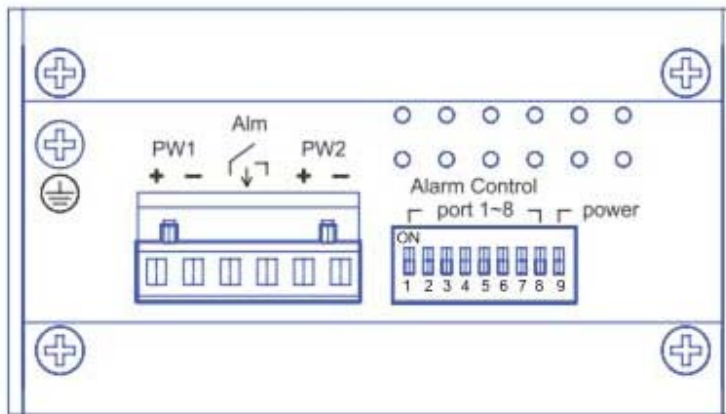

The DIP Switch setting for the Alarm Relay Output is shown as below:

Pin No. #	Status	Description
P1 to P8 (Pin1 ~8)	ON	To enable port link down alarm at this port.
	Off	To disable port link down alarm at this port.
P9	ON	To enable power failure alarm.
	Off	To disable power failure alarm.

4-5. Cabling

The UTP cable connection between the switch and the attached devices (switches, hubs, workstations, etc.) must be less than 100 meters (328 ft.) in length.

4-6. System Power-On and Testing

1. Take the Industrial 8-port Fast Ethernet Switch out of the box.
2. To place the switch on the DIN-Rail track, please refer to the **Mounting Installation** section.
3. Pull the terminal block off the switch and wire the power lines. Please refer to the **Wiring the DC Power Inputs** section of how to wire the power inputs.
4. PWR1 and PWR2 dual power inputs can be connected to power sources simultaneously. When the primary power source fails (the default setting is PWR1), the system will automatically switch to the secondary power source (PWR2) to prevent the power interruption occurred.
5. Check the LEDs for PWR1 and PWR2 to make sure that your switch is operating normally.
6. Use Category-5 or above straight through Ethernet cables with RJ-45 connectors to connect network devices.
7. Connect one side of the Ethernet cable with a RJ-45 connector to one of the Ethernet port (RJ-45 port). The other side of the Ethernet cable connects to the target device equipped IP address and can handle ICMP protocol as ping packet.

[Note] Make sure that the connected network switches support MDI/MDI-X function. If they do not support this function, use a crossover Ethernet cable.

8. Check the port status LED indicator (blinking green) on the switch to see if the network connection is established successfully.
9. Power on your host PC, make an Ethernet connection to the switch and check the connected port is link up. The connection diagram is shown as below:

Test Diagram

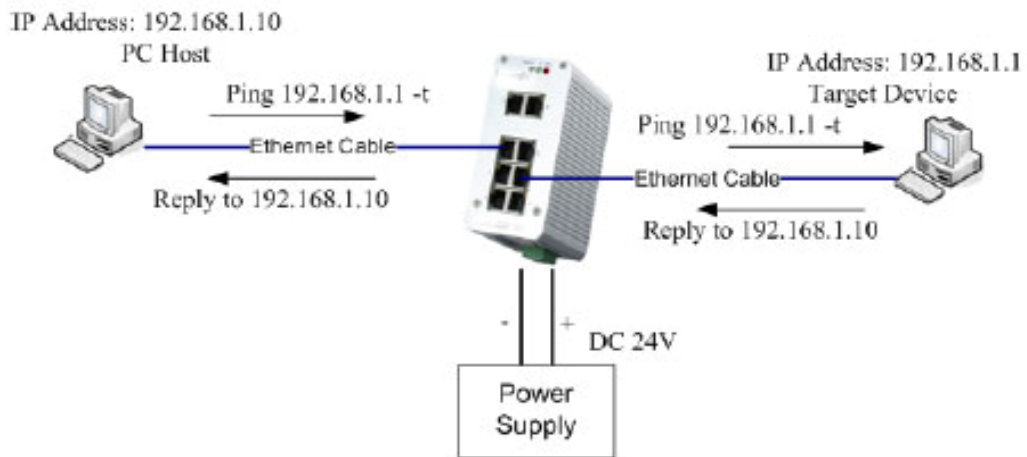

10. To enable the "Command Line mode". Click on **Run** in the Start Menu → type **Command** → click **OK** to continue.

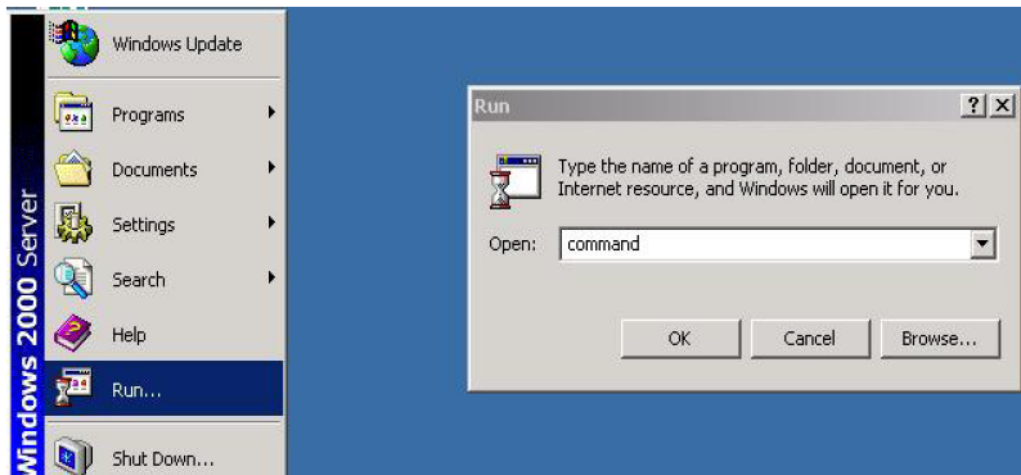

Type **ping 192.168.1.1** command to check the connection. Here uses 192.168.1.1 (IP address) as an example.

5. Packet forwarding ability

The switch features packet filtering functions for broadcast packet control protection and QoS. Both of features can provide more graceful performance in a crowded network by traffic filtering and prioritize.

This session will introduce the principle of traffic control and forwarding precedence, including “Broadcast control” and “Quality of Service”.

5-1. Broadcast Control

The switch begins to drop broadcast packets with DA (destination address) FF:FF:FF:FF:FF:FF if the received broadcast packets are more than the threshold – 198 packets/ per second at 100Mbps or 19 packets / per second at 10Mbps link speed.

All of ports are enabled with this function without any configuration to provide a better network performance and prevent network congestion with the flooding of broadcast packets.

5-2. Quality of Service

The switch supports frame type priority function High priority packet will be queued to high priority queue to share more bandwidth. The ratio of bandwidth of high priority and low priority queue is 8:1. 8 high priority packets is progressed first, then the low priority packets will be progressed afterwards.

The switch can examine the specific bits of VLAN Tag and TCP/IP TOS of IPv4 and IPv6.

IEEE 802.1Q tag based CoS

The switch will examine the 3 bits of priority field carried by a VLAN tag and maps it to the corresponding priority. A packet with priority field ranging from 0 to 3 will be treated as a low priority packet and will be stored in low priority queue. A packet with priority field ranging from 4 to 7 will be treated as a high priority packet, and will be stored in high priority queue.

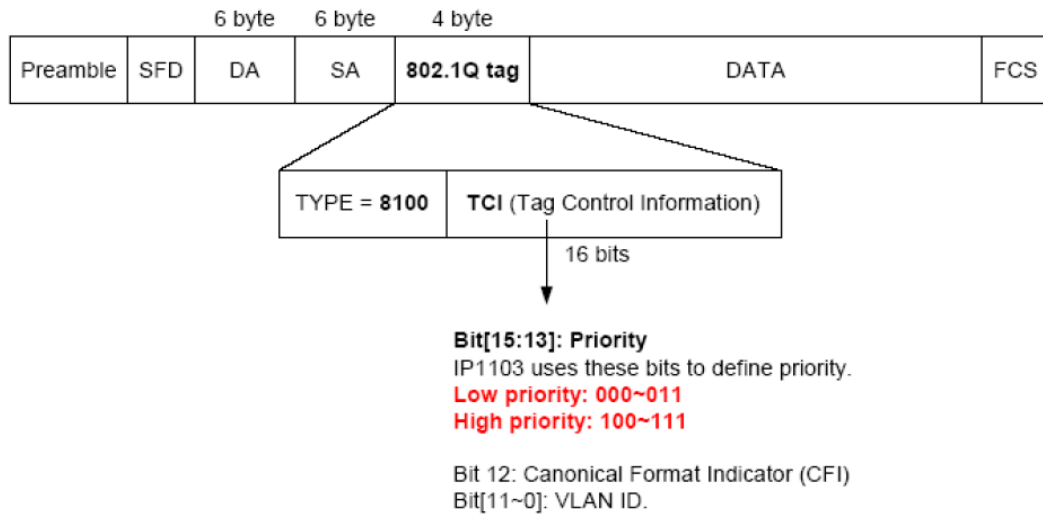

IEEE 802.1Q Type of Service for IPv4 /IPv6 packet

The switch also provides the IP layer CoS (Class of Service) function by recognizing the priority octet and mapping it to the corresponding priority. For an IPv4 packet, it is embedded in the TOS (type of Service) Octet.

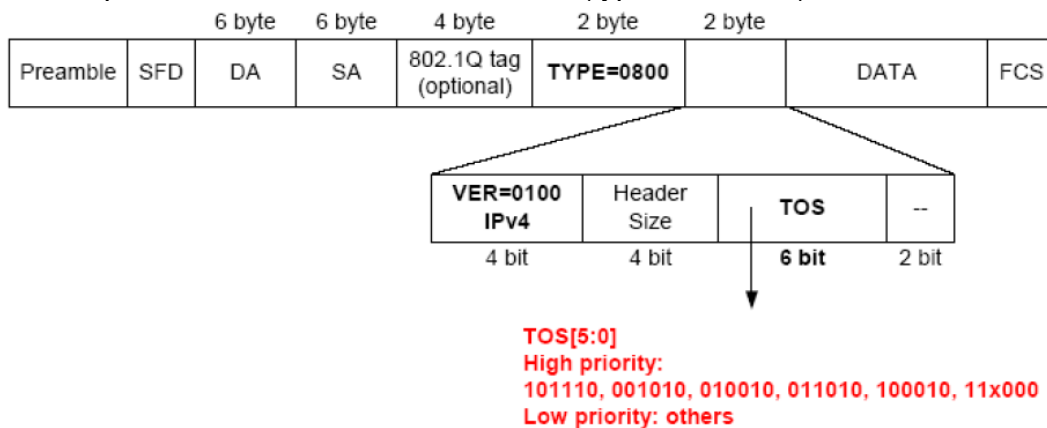

For an IPv6 data packet, the Traffic Class Octet is used to differentiate the Class of Service. When this function is enabled, the switch will automatically recognize the IP version and capture the either the TOS field (IPv4) or Traffic Class field (IPv6) and distributes the packet into High or Low Queue.

6. Trouble shooting

- ⦿ Make sure you are using the correct DC power suppliers (DC12 to 48 V). Do not use power suppliers with DC output over 48V. It may damage devices.
- ⦿ Select Ethernet cables with specifications suitable for your applications to set up your systems. Ethernet cables are categorized into unshielded twisted-pair (UTP) and shielded twisted-pair (STP) cables. Category 3, 4, 5, 6 Ethernet cables are suitable for systems with 10 Mbps transmission speed. For systems with 100 Mbps transmission speed, Category 5, 6 Ethernet cables are the only suitable specifications for this environment. You also need to make sure that the distance between each node cannot be longer than 100 meters (328 feet).
- ⦿ If the power LEDs go off when the power cord is plugged in, a power failure might be occurred. Check the power output connection to see if there is any error at the power source. If you still cannot solve the problem, contact your local dealer for assistance.

7. Technical Specifications

Technology	
Standard	IEEE802.3 10Base-T IEEE802.3u 100Base-TX IEEE802.3u 100Base-FX IEEE802.3x flow control
Switch Technology	Store and forward technology with 2.0 Gbps Switch Fabric.
System Performance	
Aggregate System Throughput	1.49Mpps
MAC Address	2K MAC
Packet Buffer	448Kbits
Transfer Packet Size	148,80pps for Ethernet 10Base-T 148,810pps for Fast Ethernet 100Base-TX Packet size from 64~1552 Bytes (Long Packet forwarding ability)
Broadcast storm control	Default enabled. traffic threshold: 200 packets/ Sec. @100Mbps 20 packets/Sec. @ 10Mbps
Class of Service	Provides 2 packet forwarding Queues: High Queue (4~7), Low Queue (0~3) with 16:1 forwarding ratio.
Quality of Service	Default Enabled. Supports VLAN tag priority and IPv4/IPv6 packet precedence.
Event alarm relay	Provides port and power event alarm; Enabled by 9-PIN DIP switch.
Interface	
Number of Ports	*8 x 10/100 Base-TX with Auto MDI/MDI-X, Auto-Negotiation function
Connectors	10/100 Base-TX: RJ-45 Power: Terminal block connector Alarm relay: Terminal block connector with 1A @DC24V carry ability.
Cables	RJ-45: Cat-3, Cat-4, Cat-5 or Cat-5e unshielded twisted pair or shielded twisted pair cable. The Max. Link distance is 100 meters.
Diagnostic LED	Per system: Power (Green) x2 10/100TX port: Speed (Yellow on/ 100Mbps ,Yellow off/10Mbps), Link/Activity (Green on/ Green blinks) Alarm: Port /Power Event (Red on)

Power Requirements	
System Power	2 Power inputs with redundancy and polarity reverse protection. Voltage: DC 24V (12~48V)
Power Consumption	8 Watts @ DC 24V (8 x 10/100 Base-TX) 12 Watts @ DC 24V(6 x 10/100 Base-TX+2 x 100 Base-FX)
Mechanical	
Installation	DIN-Rail mount
Case	IP-31 grade aluminum metal case
Dimension	120mm(H) x 55mm (W) x 108mm (D) (with DIN rail clip)
Weight	0.775kg with package 0.525kg without package
Environmental	
Operating Temperature	-10 ~ °C 70°C
Operating Humidity	0% ~ 95%, non-condensing
Storage Temperature	-20 ~ 80°C
Storage Humidity	5%~ 90%, non-condensing
Regulatory Approvals	
EMI	FCC class B, CE/EN55022 class B.
EMS	CE/EN61000-4-2, CE/EN61000-4-3 CE/EN61000-4-4, CE/EN61000-4-5 CE/EN61000-4-6, CE/EN61000-4-8
Shock	IEC60068-2-27
Vibration	IEC60068-2-6
Free Fall	IEC60068-2-32
MTBF	100,000hours *MIL-HDBK-217F GB(MILITARY HANDBOOK) standard