

**solar**edge

# **SolarEdge Inverter Installation Guide**

Version 2.2



# Disclaimers

## Important Notice

---

Copyright © SolarEdge Inc. All rights reserved.

No part of this document may be reproduced, stored in a retrieval system or transmitted, in any form or by any means, electronic, mechanical, photographic, magnetic or otherwise, without the prior written permission of SolarEdge Inc.

The material furnished in this document is believed to be accurate and reliable. However, SolarEdge assumes no responsibility for the use of this material. SolarEdge reserves the right to make changes to the material at any time and without notice. You may refer to the SolarEdge web site ([www.solaredge.com](http://www.solaredge.com)) for the most updated version.

All company and brand products and service names are trademarks or registered trademarks of their respective holders.

Patent marking notice: see <http://www.solaredge.com/groups/patent>

The general terms and conditions of purchase of SolarEdge products shall apply.

The content of these documents is continually reviewed and amended, where necessary. However, discrepancies cannot be excluded. No guarantee is made for the completeness of these documents.

## Emission Compliance

---

This equipment has been tested and found to comply with the limits applied by the local regulations.

These limits are designed to provide reasonable protection against harmful interference in a residential installation. This equipment generates, uses and can radiate radio frequency energy and, if not installed and used in accordance with the instructions, may cause harmful interference to radio communications. However, there is no guarantee that interference will not occur in a particular installation. If this equipment does cause harmful interference to radio or television reception, which can be determined by turning the equipment OFF and ON, you are encouraged to try to correct the interference by one or more of the following measures:

- Reorient or relocate the receiving antenna.
- Increase the separation between the equipment and the receiver (and its antenna).
- Connect the equipment into an outlet on a circuit different from that to which the receiver is connected.
- Consult the dealer or an experienced radio/TV technician for help.

Changes or modifications not expressly approved by the party responsible for compliance may void the user's authority to operate the equipment.

## Support and Contact Information

If you have technical queries concerning our products, please contact us:

Belgium	080073041	<a href="mailto:support@solaredge.be">support@solaredge.be</a>
France	0800917410	<a href="mailto:support@solaredge.fr">support@solaredge.fr</a>
Germany	+49 89-45459730	<a href="mailto:support@solaredge.de">support@solaredge.de</a>
Italy	800 784 824	<a href="mailto:support@solaredge.it">support@solaredge.it</a>
Japan	+81.3.5530.9360	<a href="mailto:support@solaredge.jp">support@solaredge.jp</a>
APAC (Asia Pacific)		<a href="mailto:support-asia@solaredge.com">support-asia@solaredge.com</a>
US & Canada	1 877 360 5292	<a href="mailto:ussupport@solaredge.com">ussupport@solaredge.com</a>
Australia	1800149229	<a href="mailto:support@solaredge.com">support@solaredge.com</a>
Greece	00800125574	
Israel	+972 73 240-3118	
Netherlands	08000221089	
United Kingdom	0800 028 1183	
Worldwide	+972 73 240-3118	
Fax	+972 73 240-3117	

Before contact, make sure to have the following information at hand:

- Inverter and power optimizer model numbers
- Serial number of the product in question
- The error indicated on the inverter screen or on the SolarEdge monitoring portal, if there is such an indication.
- System configuration information, including the type and number of modules connected and the number and length of strings.
- The communication method to the SolarEdge monitoring portal, if the site is connected
- Inverter software version as appears in the ID status screen (see page 37)

# Table of Contents

<b>Disclaimers</b> .....	<b>1</b>
Important Notice .....	1
Emission Compliance .....	1
<b>Support and Contact Information</b> .....	<b>2</b>
<b>Table of Contents</b> .....	<b>3</b>
<b>HANDLING AND SAFETY INSTRUCTIONS</b> .....	<b>6</b>
SAFETY SYMBOLS .....	6
SAFETY INSTRUCTIONS .....	7
<b>Chapter 1: Introducing the SolarEdge System</b> .....	<b>8</b>
System Overview .....	8
SolarEdge Power Optimizer .....	8
SolarEdge Inverter .....	8
SolarEdge Monitoring Portal .....	8
Installation Procedure .....	9
Installation Equipment List .....	10
Inverter Transport and Storage .....	10
<b>Chapter 2: Installing the Power Optimizers</b> .....	<b>11</b>
Safety .....	11
Installation Guidelines .....	12
Step 1, Mounting the Power Optimizers .....	12
Step 2, Connecting a Module to a Power Optimizer .....	13
Step 3, Connecting Power Optimizers in Strings.....	14
Step 4, Verifying Proper Power Optimizer Connection.....	14
<b>Chapter 3: Installing the Inverter</b> .....	<b>16</b>
Inverter Package Contents.....	16
Identifying the Inverter .....	16
Inverter Interfaces .....	16
Mounting the Inverter .....	18
Connecting the AC to the Inverter .....	20
Grid Connection Guidelines.....	20
Connecting to AC.....	20
Connecting the Strings to the Inverter .....	22
Selecting a Residual-Current Device .....	22
<b>Chapter 4: Commissioning the Installation</b> .....	<b>23</b>
Step 1, Activating the System .....	23
Step 2, Pairing Power Optimizers to the Inverter .....	24
Step 3, Verifying Proper Operation.....	25
Step 4, Reporting and Monitoring Installation Data .....	26
The SolarEdge Monitoring System .....	26

Providing Installation Information.....	27
<b>Chapter 5: User Interface .....</b>	<b>28</b>
LCD User Buttons.....	28
Inverter Configuration – Setup Mode.....	29
Configuring the Inverter Using the Internal LCD User Buttons .....	29
Configuring the Inverter Using the External LCD Light Button .....	31
Inverter Configuration Menu Options .....	33
Inverter Status Screens – Operational Mode.....	36
Initial Inverter Status.....	36
Main Inverter Status.....	37
Energy Meter Status.....	37
Telemetry Status .....	37
ID Status .....	37
Server Communication Status .....	38
IP Status .....	38
ZigBee Status.....	38
Communication Ports Status.....	39
Fan Health Status – Three Phase Inverters.....	39
Power Control Status .....	40
<b>Chapter 6: Setting Up Communication.....</b>	<b>41</b>
Communication Connectors .....	41
Communication Types .....	42
Removing the Inverter Cover.....	42
Creating an Ethernet (LAN) Connection.....	42
Creating an RS485 Bus Connection.....	45
Creating an RS232 (UART) Connection .....	48
Creating a ZigBee Connection.....	49
Connecting a Laptop to the Inverter.....	49
Verifying the Connection .....	49
<b>Appendix A: Errors and Troubleshooting .....</b>	<b>50</b>
Troubleshooting Communication - S_OK is Not Displayed .....	50
Error Codes .....	52
Power Optimizers Troubleshooting .....	57
<b>Appendix B: Technical Specifications .....</b>	<b>58</b>
Single Phase Inverters.....	58
Three Phase Inverters .....	60
Inverter and Mounting Bracket Dimensions .....	63
Single Phase Inverter and Mounting Bracket .....	63
Three Phase Inverter and Mounting Bracket.....	65
<b>Appendix C: Safe DC .....</b>	<b>67</b>
<b>Appendix D: Fan Maintenance and Replacement.....</b>	<b>68</b>
Fan Maintenance .....	68

---

Fan 2 Replacement .....	68
<b>Appendix E: Replacing and Adding System Components.....</b>	<b>70</b>
Replacing an Inverter .....	70
Adding, Removing or Replacing Power Optimizers.....	70

# HANDLING AND SAFETY INSTRUCTIONS

During installation, testing and inspection adherence to all the handling and safety instructions is mandatory.

## SAFETY SYMBOLS

---

The following safety symbols are used in this document. Familiarize yourself with the symbols and their meaning before installing or operating the system.

**WARNING!**

Denotes a hazard. It calls attention to a procedure that, if not correctly performed or adhered to, could result in **injury or loss of life**. Do not proceed beyond a warning note until the indicated conditions are fully understood and met.

**CAUTION:**

Denotes a hazard. It calls attention to a procedure that, if not correctly performed or adhered to, could result in **damage or destruction of the product**. Do not proceed beyond a caution sign until the indicated conditions are fully understood and met.

**NOTE:**

Denotes additional information about the current subject.

**IMPORTANT SAFETY FEATURE:**

Denotes information about safety issues.



# SAFETY INSTRUCTIONS



**WARNING!**

The cover must be opened only after shutting off the inverter ON/OFF switch located at the bottom of the inverter. This disables the DC voltage inside the inverter. Wait five minutes before opening the cover. Otherwise, there is a risk of electric shock from energy stored in the capacitors.

Inverter ON/OFF switch  
 0=OFF  
 1=ON

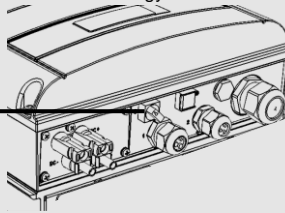

**WARNING!**

Before operating the inverter, ensure that the AC power cable and wall outlet are grounded properly.



**WARNING!**

Opening the inverter and repairing or testing under power must be performed only by qualified service personnel familiar with this inverter.



**WARNING!**

Do not touch the PV panels or any rail system connected when the inverter switch is ON, unless grounded.



**CAUTION:**

This unit must be operated under the specified operating specifications, as described in the latest technical specification datasheet, available on the SolarEdge website at <http://www.solaredge.com/groups/products/overview>.



**CAUTION:**

The inverters are IP65 rated. Unused connectors and glands should be sealed with the provided seals.



**NOTE:**

Use PV modules rated according to IEC 61730 class A.





**NOTE:**

The  symbol appears at grounding points on the SolarEdge equipment. This symbol is also used in this manual.



**NOTE:**

The following warning symbols appear on the inverter warning label:

Symbol	Warning
	Risk of electric shock
	Risk of electric shock from energy stored in the capacitor. Do not remove cover until 5 minutes after disconnecting the all sources of supply.
	Hot surface – To reduce the risk of burns, do not touch.

# Chapter 1: Introducing the SolarEdge System

## System Overview

---

The SolarEdge power harvesting solution maximizes the power output from any type of solar Photovoltaic (PV) installation while reducing the average cost per watt. The following sections describe the system components.

### SolarEdge Power Optimizer

SolarEdge power optimizers are DC-DC converters connected to PV modules in order to maximize power harvesting by performing independent Maximum Power Point Tracking (MPPT) at the module level.

The power optimizers regulate the string voltage at a constant level, regardless of string length and environmental conditions. The power optimizers include a safety voltage function that automatically reduces the output of each power optimizer to 1 Vdc during fault conditions, when disconnected from the inverter or when the inverter's ON/OFF switch is turned OFF. Each power optimizer also transmits module performance data over the DC power line to the inverter.

Two types of power optimizers are available:

- Module Add-on power optimizer – connected to one or more modules
- Module embedded power optimizer – embedded into a module

### SolarEdge Inverter

The SolarEdge inverter efficiently converts DC power from the modules into AC power that can be fed into the main AC service of the site and from there to the grid. The inverter also receives the monitoring data from each power optimizer and transmits it to a central server (the SolarEdge monitoring portal; requires Internet connection).

### SolarEdge Monitoring Portal

The SolarEdge monitoring portal enables you to monitor the technical and financial performance of one or more SolarEdge sites. It provides information about present and past performance of each module individually and about the system as a whole.

# Installation Procedure

---

The following is the procedure for installing and setting up a new SolarEdge site. Many of these also apply to modification of an existing site.

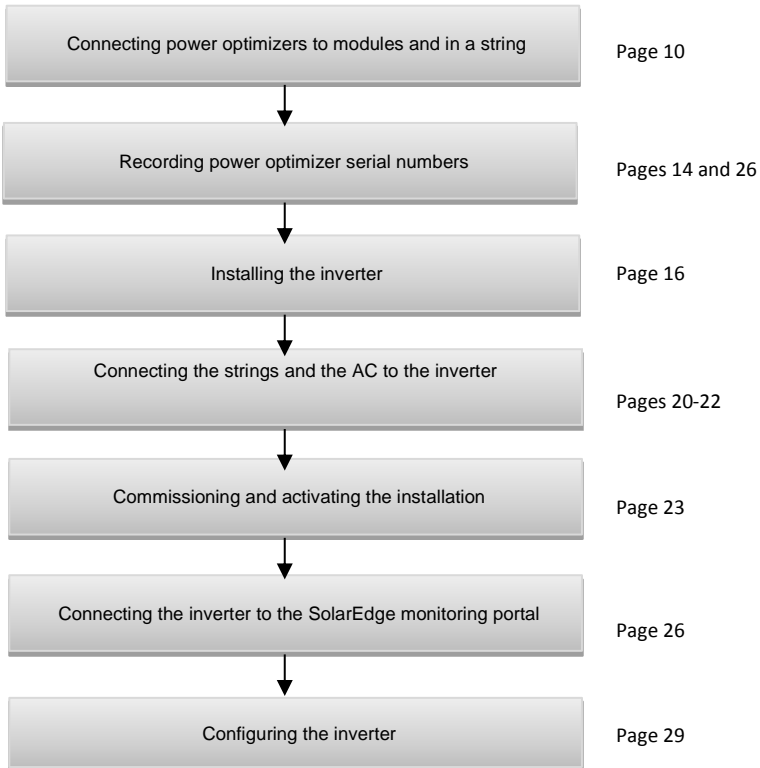

## Installation Equipment List

---

Standard tools can be used during the installation of the SolarEdge system. The following is a recommendation of the equipment needed for installation:

- Allen screwdriver for M6/M8 screw types
- Standard flat head screwdrivers set
- Voltage tester screwdriver
- Drilling motor and bits suitable for the surface on which the inverter will be installed Suitable screws for attaching the inverter mounting bracket to the surface to which it will be connected
- M6 (1/4") or M8 (5/16") stainless bolts, nuts, and washers for attaching the power optimizer to the racking
- MC4 Crimper
- Wire cutters
- Wire strippers
- Voltmeter

For installing the communication options, you may also need the following:

- For Ethernet:
  - CAT5/6 twisted pair Ethernet cable
  - RJ-45 plugs
  - RJ-45 crimper
- For RS485:
  - Four- or six-wire twisted pair
  - Small flat head screwdriver set

## Inverter Transport and Storage

---

Transport the inverter in its original packaging, facing up and without exposing it to unnecessary shocks. If the original package is no longer available, use a similar box that can withstand the weight of the inverter (refer to the inverter weight in *Appendix B: Technical Specifications* on page 58), has a handle system and can be closed fully.

Store the inverter in a dry place where ambient temperatures are -25°C - +65°C / -13°F - 149°F.

# Chapter 2: Installing the Power Optimizers

## Safety

The following notes and warnings apply when installing the power optimizers:

**WARNING!**

When modifying an existing installation, turn OFF the inverter ON/OFF switch and the AC circuit breaker on the main AC distribution panel.

**WARNING!**

Input and output connectors are not watertight until mated. Open connectors should be mated to each other or plugged with appropriate watertight caps.

**CAUTION:**

This unit must be operated according to the operating specifications in this document.

**CAUTION:**

Cutting the power optimizer input or output cable connector is prohibited and will void the warranty.

**CAUTION:**

Power optimizers are IP65/NEMA4 rated. Choose a mounting location where optimizers will not be submerged in water.

**CAUTION:**

If you intend to mount the optimizers directly to the module or module frame, first consult the module manufacturer for guidance regarding the mounting location and the impact, if any, on module warranty. Drilling holes in the module frame should be done according to the module manufacturer instructions.

**CAUTION:**

Installing a SolarEdge system without ensuring compatibility of the module connectors with the optimizer connectors may be unsafe and could cause functionality problems such as ground faults, resulting in inverter shut down.  
In order to ensure mechanical compatibility of the SolarEdge optimizers and the modules to which they are connected:

- Use identical connectors from the same manufacturer and of the same type on both the power optimizers and on the modules; or
- Verify that the connectors are compatible in the following way:
  - The connector manufacturer should explicitly verify compatibility with the SolarEdge optimizer connector; and
  - A third-party test report by one of the listed external labs (TUV, VDE, Bureau Veritas UL, CSA, InterTek) should be obtained, verifying the compatibility of the connectors.

**IMPORTANT SAFETY FEATURE:**

Modules with SolarEdge power optimizers are safe. They carry only a low safety voltage before the inverter is turned ON. As long as the power optimizers are not connected to the inverter or the inverter is turned OFF, each power optimizer will output a safe voltage of 1V.

## Installation Guidelines

- This chapter refers only to the module add-on power optimizers. For module-embedded models, refer to the installations instructions supplied with the embedded module.
- The power optimizer can be placed in any orientation.
- Position the power optimizer close enough to its module so that their cables can be connected.
- To allow proper heat dissipation, maintain a 1" /2.5 cm clearance distance between the power optimizer and other surfaces.
- The minimum and maximum string length guidelines are stated in the power optimizer datasheets.
- Refer to the SolarEdge Site Designer for string length verification. The SolarEdge Site Designer is available on the SolarEdge website at <http://www.solaredge.com/groups/support/downloads>, under Software Tools.
- Completely shaded modules may cause their power optimizers to temporarily shut down. This will not affect the performance of the other power optimizers in the string, as long as the minimum numbers of power optimizers are connected in a string to modules. If under typical conditions fewer than the minimum optimizers are connected to unshaded modules, add more optimizers to the string.
- Do not leave the power optimizers connectors uncovered. Open connectors should be mated to each other.

## Step 1, Mounting the Power Optimizers

- 1 Determine the power optimizer mounting location and use the power optimizer mounting brackets to attach the power optimizer to the support structure (see Figure 1).
- 2 If required, mark the mounting holes locations and drill the holes.

**CAUTION:**

Do not drill through the power optimizer or through the mounting holes. The drilling vibrations can damage the power optimizer and will void the warranty.

- 3 Attach each power optimizer to the rack using the M6 (1/4") or M8 (5/16") stainless steel bolts, nuts and washers.
- 4 Verify that each power optimizer is securely attached to the supporting structure or the module.

**NOTE:**

Record power optimizer serial numbers and locations, as described in *Providing Installation Information* on page 27.

## Step 2, Connecting a Module to a Power Optimizer

- Connect the Plus (+) output connector of the module to the Plus (+) input connector of the power optimizer.
- Connect the Minus (-) output connector of the module to the Minus (-) input connector of the power optimizer.

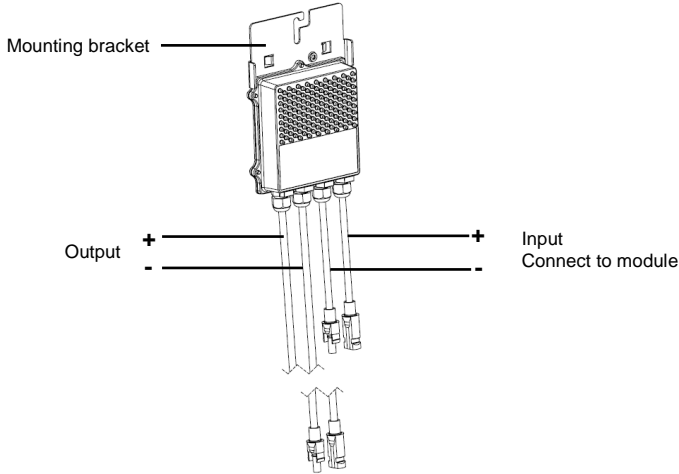

Figure 1: Power optimizer connectors



**NOTE:**

Images are for illustration purposes only. Refer to the label on the product to identify the plus and minus input and output connectors.

## Step 3, Connecting Power Optimizers in Strings

You can construct parallel strings of unequal length, that is, the number of power optimizers in each string does not have to be the same. The minimum and maximum string lengths are specified in the power optimizers' datasheets. Refer to the SolarEdge Site Designer for string length verification.

**NOTE:**

String length should not exceed 300m from DC+ to DC- of the inverter. Use at least 4 mm<sup>2</sup> DC cables.

- 1 Connect the Minus (-) output connector of the string's first power optimizer to the Plus (+) output connector of the string's second power optimizer.
- 2 Connect the rest of the power optimizers in the string in the same manner.

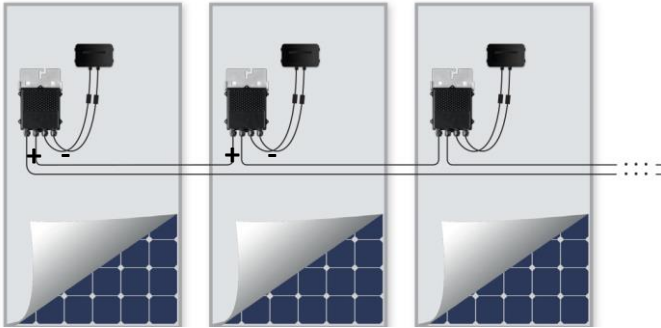

Figure 2: Power optimizers connected in series

- 3 If you intend to monitor the installation, using the SolarEdge monitoring portal, record the physical location of each power optimizer, as described in Providing Installation Information on page 27.

**CAUTION:**

Do not leave the power optimizers connectors disconnected. Open connectors should be mated to each other.

## Step 4, Verifying Proper Power Optimizer Connection

After a module is connected to a power optimizer, the power optimizer outputs a safe voltage of 1V.

Therefore, the total string voltage should be equal to ~1V times the number of power optimizers connected in series in the string. For example, if 10 power optimizers are connected in a string, then 10V should be produced.

- Make sure the modules are exposed to sunlight during this process; otherwise, the power optimizers may not be powered. If you use a tracker, the power optimizer will turn ON only if the tracker is tracking the sun and the module provides at least 2W.
- In SolarEdge systems, due to the introduction of power optimizers between the PV modules and the inverter, the short circuit current  $I_{sc}$  and the open circuit voltage  $V_{oc}$  hold different meanings from those in traditional systems. For more information about the SolarEdge systems' string voltage and current, refer to the  $V_{oc}$  and  $I_{sc}$  in *SolarEdge Systems Technical Note*, available on the SolarEdge website at: [http://www.solaredge.com/files/pdfs/isc\\_and\\_voc\\_in\\_solaredge\\_sytems\\_technical\\_note.pdf](http://www.solaredge.com/files/pdfs/isc_and_voc_in_solaredge_sytems_technical_note.pdf)
- Isolation measurement using a measurement device of up to 1000V is acceptable.



▶ **To verify proper power optimizers connection:**

- 1** Measure the voltage of each string individually before connecting it to the other strings or to the inverter. Verify correct polarity by measuring the string polarity with a voltmeter. Use a voltmeter with at least 0.1V measurement accuracy.
- 2** For troubleshooting power optimizers operation problems, refer to *Power Optimizers Troubleshooting* on page 57.

## Chapter 3: Installing the Inverter

Install the inverter either before or after the modules and power optimizers have been installed.



### CAUTION:

Do not rest the connectors at the bottom of the inverter on the ground, as it may damage them. To rest the inverter on the ground, lay it on its back, front or side.

## Inverter Package Contents

- One SolarEdge inverter
- One mounting bracket
- Two Allen screws for fastening the inverter to the mounting bracket
- This installation guide
- Quick installation guide
- Inverter activation instructions (may include an activation card)

## Identifying the Inverter

Refer to the sticker on the inverter that specifies its **Serial Number** and its **Electrical Ratings**. Provide the serial number when contacting SolarEdge support. The serial number is also required when opening a new site in the SolarEdge monitoring portal.

In the following sections, unless otherwise indicated, instructions apply to both single-phase and three-phase inverters, though only one graphical example may be presented.

## Inverter Interfaces

The following shows the inverter connectors and components, located at the bottom of the inverter:

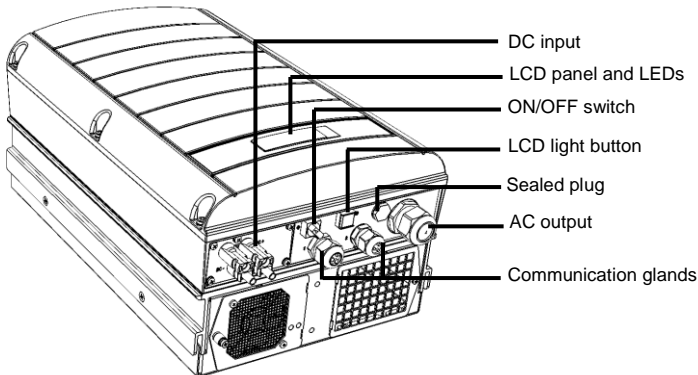

Figure 3: Inverter connectors (three phase example)

- **LCD panel:** displays inverter information and configuration parameters

- **LCD LEDs:** Three LEDs indicate the following inverter statuses (see Figure 4):

Color	Description	Functionality
Green	Power production	<p><b>On</b> - The inverter is producing power.</p> <p><b>Blinking</b> - Standby mode. The inverter is in Standby mode until its working voltage is reached. The inverter then enters Production mode and produces power.</p> <p><b>Off</b> - The inverter is not producing power. This may be during Night mode, when the inverter ON/OFF switch is OFF or when an error occurs.</p>
Yellow	Module communication and inverter shutdown	<p>Blinking:</p> <ul style="list-style-type: none"> <li>■ Monitoring information is being received from a power optimizer.</li> <li>■ The inverter is being shut down.</li> </ul>
Red	Fault	<p><b>On</b> - There is an error. Refer to <i>Appendix A: Errors and Troubleshooting</i> on page 50 for more information.</p> <p><b>Blinking</b> - The inverter is being shut down.</p>

All LEDs are on while the inverter is being configured.

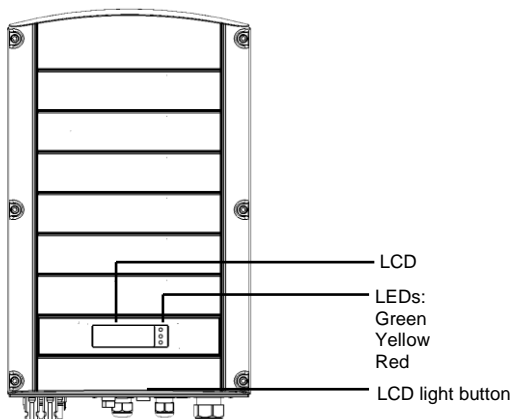

Figure 4: Inverter front view

- **AC output**

AC cable external gauge:

- Single phase inverters: PG21 (9-16mm diameter)
- Three phase inverters: M32 (15-21mm diameter)

- **DC inputs:** For connection of the PV installation



**CAUTION:**

Do not remove the six screws on the DC metal panel as it may harm the inverter sealing and void the warranty.

- **ON/OFF switch:** Turning this switch ON starts the operation of the power optimizers, enables power production and allows the inverter to begin exporting power to the utility grid. Turning it OFF reduces the power optimizer voltage to a low safety voltage and inhibits exportation of power. When this switch is OFF, the inverter control circuitry remains powered up.
- **LCD light button:** Pressing this button lights up the LCD for 30 seconds. In addition, you can press this button to access configuration menu options, as described on page 31.
- Two **communication glands**, for connection of inverter communication options. Each gland has three openings. Refer to *Chapter 6: Setting Up Communication* on page 41 for more information.

## Mounting the Inverter

- 1 Determine the inverter mounting location, on a wall or pole, as follows:
  - To allow proper heat dissipation, maintain the following minimum clearance areas between the inverter and other objects:
    - 8" / 20 cm to the top and bottom of the inverter
    - 4" / 10 cm to the right and left of the inverter
    - When installing inverters side by side, leave at least 16" / 40 cm between inverters
    - When installing inverters one above of the other, leave at least 16" / 40 cm between inverters.
  - Position the mounting bracket against the wall/pole and mark the drilling hole locations (refer to *Inverter and Mounting Bracket Dimensions* on page 63):
    - Ensure that the U-shaped indentations are facing up and the "UP" marking is correctly oriented, as shown below:

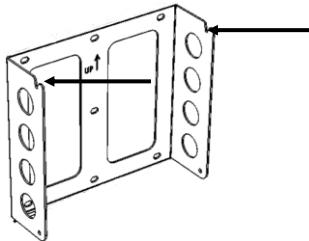

**Figure 5: Brackets with U-shaped Indentations Facing Up**

- Use at least two bracket holes. Additional holes can be used to fix the bracket. Determine which and how many holes to use according to mounting surface type and material.



**NOTE:**

Make sure the mounting surface or structure can support the weight of the inverter (single phase: 20-21 kg; three phase: 33 kg) and bracket (1.3 kg).

- 2 Drill the holes and mount the bracket. Verify that the bracket is firmly attached to the mounting surface.

- 3 Hang the inverter on the bracket using the screws at the top of the inverter, as shown below. Let the inverter lay flat against the wall or pole.

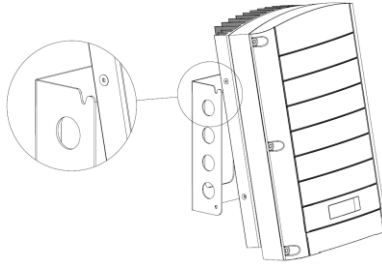

Figure 6: Hanging the inverter on the bracket



**CAUTION:**

**HEAVY OBJECT.** The single phase inverter weighs 20-21 kg and the three phase weighs 33 kg. To avoid muscle strain or back injury, use proper lifting techniques, and if required - a lifting aid when removing or replacing.

- 4 Insert the two supplied screws through the outer heat sink fin on both sides of the inverter and into the bracket. Tighten the screws with a torque of 4.0 N\*m / 2.9 lb\*ft.

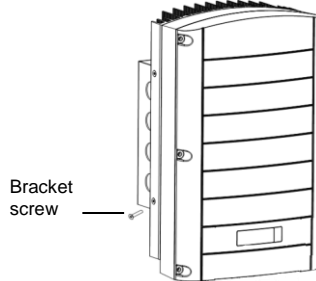

Figure 7: Inserting the screws into the outer heat sink fins

## Connecting the AC to the Inverter

Refer to *Appendix B: Technical Specifications* on page 58, for specifications of inverters in different countries.

### Grid Connection Guidelines



#### NOTE:

Three phase inverters require neutral connection at all times (only grids with neutral connection are supported).

- For installation on a delta grid without neutral, multiple single phase inverters can be used.
- For more wiring information refer to the SolarEdge Recommended AC Wiring Application Note, available on the SolarEdge website at <http://www.solaredge.com/files/pdfs/application-note-recommended-wiring.pdf>
- When connecting multiple single phase inverters in an installation connected to a three-phase grid, phase balancing may be required by the utility or grid operator. Phase balancing is supported in the SolarEdge inverters. For detailed information, refer to the *SolarEdge Phase Balancing Manual*, available on the SolarEdge website at [http://www.solaredge.com/files/pdfs/phase\\_balancing\\_connection\\_guide.pdf](http://www.solaredge.com/files/pdfs/phase_balancing_connection_guide.pdf).

### Connecting to AC

Use three wires cable for a single phase connection or five wires cable for three phase connection. The maximum wire size for the input terminal blocks is 16mm<sup>2</sup>.

- 1 Turn OFF the AC circuit breaker.
- 2 Open the inverter cover's six Allen screws and carefully move the cover vertically before lowering it.



#### CAUTION:

When removing the cover, make sure not to damage internal components. SolarEdge will not be held responsible for any components damaged as a result of incautious cover removal.

- 3 Strip 58 mm / 2.32" of the external cable insulation and strip 8 mm / 0.32" of the internal wire insulation.

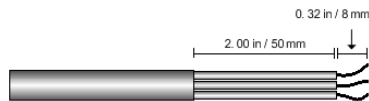

Figure 8: Insulation stripping – AC (3-wire cable)

- 4 Open the AC cable gland and insert the cable through the gland (see Figure 3).



#### WARNING!

Turn OFF the AC before connecting the AC terminals. Connect the equipment grounding wire before connecting the AC Line and Neutral wires.

- Depending on the inverter type (single phase or three phase), connect the AC, as follows. Connect the PE (grounding) wire first.

Single Phase Inverter	
Wire type	Connect to terminal
Protective Earth	PE
Line	L
Neutral	N

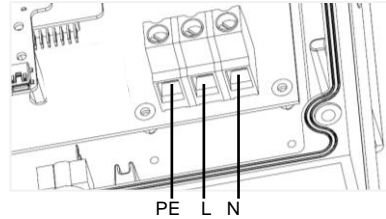

Figure 9: Single Phase Inverter AC Terminals

Three Phase Inverter	
Wire type	Connect to terminal
Line 1	L1
Line 2	L2
Line 3	L3 (feeds the internal power supply)
Protective Earth	PE
Neutral	N

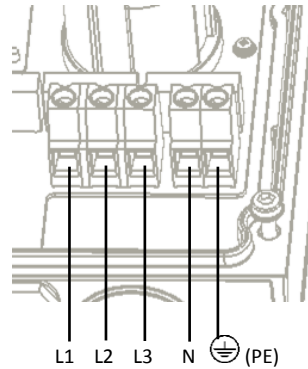

Figure 10: Three Phase Inverter AC Terminals



**NOTE:**

If power control is enabled, it is important to respect the order of grid lines connection to the inverter. A 120deg phase difference should be kept between L1 to L2 and between L2 to L3 (L1-L2-L3 and not, for example L1-L3-L2).

If the grid lines are not in this order, an error is displayed on the LCD and the inverter will not produce power.

- Tighten the screws of each terminal with a torque of 1.2-1.5 N\*m / 0.88-1.1 lb\*ft.
- Check that the wires are fully inserted and cannot be pulled out easily.
- Tighten the AC cable gland with a torque of 2.8-3.3 N\*m / 2.0-2.4 lb\*ft.
- Verify that there are no unconnected wires to the inverter and that the unused terminal screws are tightened.

## Connecting the Strings to the Inverter

Connect the string to the DC input pairs. If required, connect additional strings in parallel using an external combiner box/branch cables before connecting to the inverter.



### NOTE:

Functional electrical earthing of DC-side negative or positive poles is prohibited because the inverter has no transformer. Grounding (earth ground) of module frames and mounting equipment of the PV array modules is acceptable.



### NOTE:

SolarEdge's fixed input voltage architecture enables the parallel strings to be of different lengths. Therefore, they do not need to have the same number of power optimizers, as long as the length of each string is within the permitted range.

- 1 Connect the DC connectors of each string to the DC+ and DC- connectors according to the labels on the inverter.

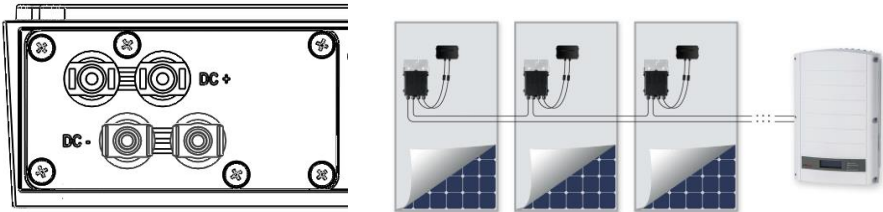

Figure 11: Inverter DC Connections

## Selecting a Residual-Current Device



### IMPORTANT SAFETY FEATURE:

All SolarEdge inverters incorporate a certified internal Residual Current Device (RCD) in order to protect against possible electrocution and fire hazard in case of a malfunction in the PV array, cables or inverter. There are 2 trip thresholds for the RCD as required for certification (DIN VDE 0126-1-1). The default value for electrocution protection is 30mA, and for slow rising current is 300mA.

If an external RCD is required by local regulations, check which type of RCD is required for the relevant electric code. SolarEdge recommends using a type-A RCD. The recommended RCD value is 100mA or 300mA unless a lower value is required by the specific local electric codes. When required by local regulations, the use of an RCD type B is permitted.

In installations where the local electric code requires the use of a lower leakage RCD, the discharge current of capacitive parasitic leakage may trip the RCD. Use the following procedure to avoid this problem:

- Select an appropriate RCD to ensure proper operation of the installation. A 30mA RCD may still trip at 15mA (according to IEC 61008). Good quality RCDs will trip at a higher value.
- PV modules with low capacitance leakage to the frame are preferable.

For detailed information, refer to the *RCD Selection for SolarEdge Inverters Application Note*, available on the SolarEdge website at <http://www.solaredge.com/files/pdfs/se-application-rcd-selection.pdf>.



# Chapter 4: Commissioning the Installation

The following workflow describes how to activate the system, commission the installation, and verify the proper functioning of the system.

## Step 1, Activating the System

- 1 Verify that the inverter ON/OFF switch is OFF. Turn ON the AC breaker.



**WARNING!**

ELECTRICAL SHOCK HAZARD. Do not touch uninsulated wires when the inverter cover is removed.

- 2 Activate the inverter according to the activation instructions supplied in the inverter package.
- 3 Verify that the inverter is configured to the proper country: Press the LCD light button until reaching the ID status screen:

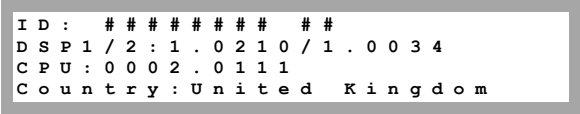

- 4 If required, perform the following before closing the inverter cover:
  - Country settings, or inverter configuration using the internal LCD user buttons – refer to *Chapter 5: User Interface* on page 28.
  - Communication options connections –refer to *Chapter 6: Setting Up Communication* on page 41.
- 5 Attach the inverter cover and secure it by tightening the screws with a torque of 4.0 N\*m/ 2.9 lb\*ft. For proper sealing, first tighten the corner screws and then the two central screws. The following figure illustrates recommended order:

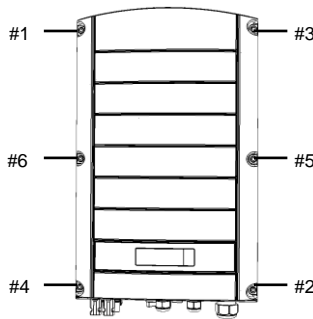

Figure 12: Tightening order of the screws

- 6 If an additional external DC switch is installed between the power optimizers and the inverter(s) then turn it ON.

A status screen similar to the following appears on the inverter LCD panel:



- 7** Verify that the following information appears on the LCD panel:
- **P\_OK**: Appears only upon first telemetry reception from the power optimizers. Indicates connection with the power optimizers and that at least one power optimizer is sending monitoring data. If P\_OK does not appear, check the power optimizer, string, and DC input connections.
  - **000/000**: Appears only upon first telemetry reception from the power optimizers. Indicates the number of power optimizers that have been paired to this inverter. At this stage, the number should be 000, since no power optimizers have been paired.
  - **S\_OK**: the connection to the SolarEdge monitoring portal is successful (should appear only if the inverter is connected to the server). If S\_OK is not displayed and the inverter is connected to the server, refer to *Appendix A: Errors and Troubleshooting* on page 50.
  - **Vac [V]** - the grid AC output voltage. Verify the correct value.
  - **Vdc [V]** - the DC input voltage of the longest string connected to the inverter. There should be a safety voltage of 1V for each power optimizer in the string.

**NOTE:**

A measurement error on the inverter LCD of  $\pm 3V$  is acceptable.



- **Pac [W]** - the AC output power (should be **0.0** since the inverter is OFF).
- **OFF** – The inverter ON/OFF switch is in the OFF position.

## Step 2, Pairing Power Optimizers to the Inverter

Once all connections are made, all the power optimizers must be logically paired to their inverter. The power optimizers do not start producing power until they are paired with an inverter. This step describes how to assign each inverter to the power optimizers from which it will produce power. Perform this step when the modules are exposed to sunlight.

- 1** Verify that the inverter ON/OFF switch is OFF.
- 2** Press and hold down the inverter LCD light button for about **10 seconds**. The following message is displayed:

```
Keep holding button
for pairing, release
to enter menu...
Remaining: 3 sec
```

Keep holding for 5 seconds until the following is displayed:

```
Pairing
Turn Switch To On
```

- 3** Turn the inverter ON/OFF switch to ON **within 5 seconds**. If you wait longer than 5 seconds the inverter exits the pairing mode.

The following message is displayed indicating that the inverter is performing the pairing.

```
Pairing
Remaining [sec]: 180
```

- 4** Wait for the completion of the pairing (remaining seconds is 0). If pairing fails, an error is displayed. In this case, repeat the pairing steps. If the problem persists, contact SolarEdge Support. When pairing succeeds, the following message is displayed:

```
Pairing
Pairing Completed
```

- 5** The system startup process begins:
- Since the inverter is ON, the power optimizers start producing power and the inverter starts converting AC.

**WARNING!**

After you turn ON the inverter ON/OFF switch, the DC cables carry a high voltage and the power optimizers no longer output a safe 1V.

- When the inverter starts converting power after the initial connection to the AC, the inverter enters Standby mode until its working voltage is reached. This mode is indicated by the flickering green inverter LED.
- While the inverter is in Standby mode, it monitors the grid and verifies correct grid voltage and frequency. The following message is displayed:

```

W a k i n g   U p . . .
R e m a i n i n g :   0 5 1 S e c

```

The countdown indicates the seconds remaining until Production mode is entered. This time is in accordance with local regulations and is typically between three to five minutes.

- When countdown is complete, the inverter enters Production mode and produces power. This mode is indicated by the steadily lit green inverter LED.

## Step 3, Verifying Proper Operation

After the wake-up time is over, a status screen similar to the following appears on the inverter LCD panel:

```

V a c [ v ]   V d c [ v ]   P a c [ w ]
2 4 0 . 7     3 7 1 . 9     2 3 4 9 . 3
P _ O K :   X X X / Y Y Y   < S _ O K >
                O N

```

- 1** Verify the following:
- The green inverter LED is steadily lit.
  - The ON/OFF indicator on the LCD panel reads **ON**.
  - **P\_OK: XXX/YYY**: There is a connection to the power optimizers and at least one power optimizer is sending monitoring data. Optimizers send telemetries in a frequency of up to 10 minutes. Initially after pairing, both XXX and YYY values show 000 and the values increase as paired power optimizers are reported.

**NOTE:**

It can take up to 20 minutes for all power optimizers to transmit their telemetries and to be counted on the LCD screen.

- **S\_OK** appears, if the inverter is connected to the SolarEdge monitoring portal.
  - **Vac [V]** specifies the measured grid AC output voltage.
  - **Vdc [V]** specifies the DC input voltage, which should be between 250V and 450V in single phase inverter, or between 550V and 950V in three phase inverters.
  - **Pac [W]** specifies the **total** AC output power produced.
- 2** Take note of the serial # on the inverter label. This information is used in the SolarEdge monitoring portal to identify this inverter and is needed to open a new site in the monitoring portal.

Your SolarEdge power harvesting system is now operational.

## Step 4, Reporting and Monitoring Installation Data

**NOTE:**

This step requires connecting one of the communication options. Refer to *Chapter 6: Setting Up Communication* on page 41

### The SolarEdge Monitoring System

The SolarEdge monitoring portal enables accessing SolarEdge site information, including up-to-date information viewed in a physical or logical view.

The monitoring portal is described in detail in the *SolarEdge Monitoring Portal User Guide*, available on the SolarEdge website at <http://www.solaredge.com/files/pdfs/solaredge-monitoring-portal-user-guide.pdf>.

The SolarEdge monitoring portal can display logical and physical layouts of the installed system, as follows:

- **Logical Layout:** Shows a schematic logical layout of the components in the system, such as: inverters, strings and modules, as well as their electrical connectivity. This view enables you to see which modules are connected in each string, which strings are connected to each inverter, and so on.
- **Physical Layout:** Shows a schematic physical layout of the components in the system, such as: inverters, strings and modules, as well as their electrical connectivity. This view enables a bird's eye view of the actual location of a system component.

Using the portal, you can:

- View the latest performance of specific components.
- Find underperforming components, such as modules, by comparing their performance to that of other components of the same type.
- Pinpoint the location of alerted components using the physical layout.
- See how components are connected to each other.
- Pair power optimizers remotely

To display a logical layout, insert the inverter serial number in the new site created in the application.

When the communication between the inverter and the monitoring server is established, the logical layout will be displayed. .

To display a physical layout, you need to map the locations of the installed power optimizers. To generate a physical mapping, use either the iPhone Site Mapper application or a mapping template, which should be filled out using the detachable stickers (see *Providing Installation Information* below).

The logical and physical mapping can be used for debugging a problem using the SolarEdge monitoring portal.

If you do not report the physical and logical mapping of the installed power optimizers to SolarEdge, the SolarEdge monitoring portal will show the logical layout indicating which power optimizers are connected to which inverters, but will not show strings or the physical location of power optimizers.

The inverter may be connected to the SolarEdge monitoring portal via LAN or via an external modem connected to the inverter RS232 connector. Alternatively, you can connect the inverter to another inverter that is already connected to the server, in a master-slave configuration. Refer to *Chapter 6: Setting Up Communication* on page 41.

## Providing Installation Information

### Paper Template

Fill out the Physical Layout Template using the detachable 2D barcode stickers on each power optimizer. Once the form is completed, scan it and upload the scanned file to the SolarEdge monitoring portal during site registration. For an example paper template, refer to <http://www.solaredge.com/files/pdfs/physical-layout-template.pdf>.

### iPhone Site Mapper

Use the SolarEdge Site Mapper iPhone application to scan the power optimizer and inverter 2D barcodes. The application creates an XML file that can be uploaded to the SolarEdge monitoring portal during site registration. The SolarEdge Site Mapper can be downloaded from the Apple iTunes Store.

For detailed information, refer to the *SolarEdge Site Mapper Software Guide* or to the *Site Mapper demo movie*, available on the SolarEdge website at <http://www.solaredge.com/groups/installer-tools/site-mapper>.

### Creating a Site in the SolarEdge Monitoring Portal

Create the site in the monitoring portal using the registration form available at the following link: <http://www.solaredge.com/groups/site-registration>. Fill out all required information in the form, which includes information about your installation, as well as details about its logical and physical mapping.

# Chapter 5: User Interface

## LCD User Buttons

Four buttons are located inside the inverter, above the LCD panel and are used for controlling the LCD menus, as shown below:

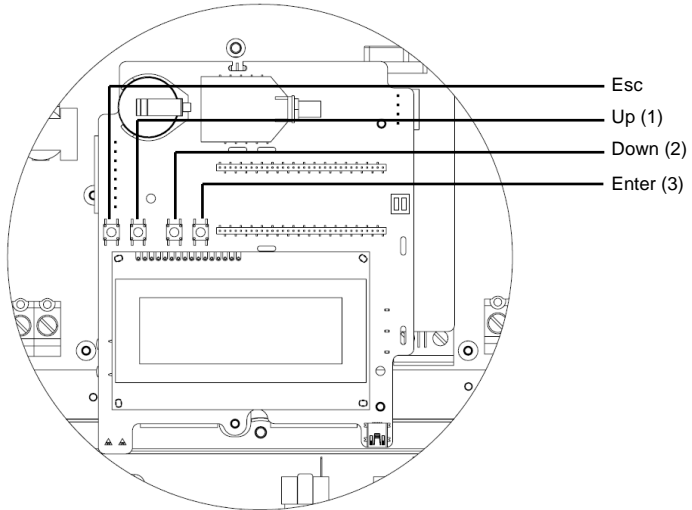

**Figure 13: LCD internal user buttons**

- **Esc:** Moves the cursor to the beginning of the currently displayed parameter; goes to the previous menu, and cancels a value change with a long press (until **Aborted** is displayed).
- **Up (1), Down (2):** Moves the cursor from one menu option to another, moves among the characters of a displayed parameter, and toggles between possible characters when setting a value.
- **Enter (3):** Selects a menu option and accepts a value change with a long press (until **Applied** is displayed).

Use the three rightmost buttons for entering 123 when entering the password.

The LCD panel and buttons may be used during the following:

- **Setup mode:** After inverter installation, the field technician may perform basic inverter configuration, as described in *Configuring the Inverter Using the Internal LCD User Buttons* on page 29.
- **Operational mode:** The LCD panel allows the user to check that the inverter is working properly. Refer to *Inverter Status Screens* on page 36 for a description of this option. Use the LCD light button to toggle through the informative displays.
- **Error messages:** In the event of a problem, an error message may be displayed on the LCD panel. Refer to *Appendix A: Errors and Troubleshooting* on page 50 and to *Configuring the Inverter Using the Internal LCD User Buttons* on page 29 for more information.

## Inverter Configuration – Setup Mode

You can configure the inverter using one of the following:

- **The internal LCD user buttons** (below). When using this option, the inverter cover is removed.
- **The external LCD light button** (page 31). When using this option, removing the inverter cover is not required. This option of configuration includes a less detailed configuration menu.

### Configuring the Inverter Using the Internal LCD User Buttons

After inverter installation, a field technician may perform basic inverter configuration.

- 1 Turn the inverter ON/OFF switch to OFF (AC remains ON).



#### WARNING!

If the inverter is operating, the following message is displayed.

```
D C V O L T A G E N O T S A F E
D O N O T D I S C O N N E C T
V D C : 7 2 . 0
```

This message is displayed until the DC voltage is safe (50V). Do not open the cover until the voltage is safe or until at least five minutes have passed.

- 2 Remove the inverter cover: Open the inverter cover's six Allen screws and carefully pull the cover vertically before lowering it.



#### WARNING!

ELECTRICAL SHOCK HAZARD. Do not touch uninsulated wires when the inverter cover is removed.

- 3 Press the **Enter** button for at least 5 seconds. The following message is displayed:

```
P l e a s e   e n t e r
P a s s w o r d
* * * * *
```

- 4 Use the three right-most internal LCD user buttons to type in the following password: **12312312**. The following message is displayed:

```
C o u n t r y < I t a l y >
L a n g u a g e < e n g >
C o m m u n i c a t i o n
P o w e r   C o n t r o l
D i s p l a y
M a i n t e n a n c e
I n f o r m a t i o n
```

The inverter is now in Setup mode and all its LEDs are lit. The inverter automatically exits Setup mode if no buttons are pressed for more than 2 minutes.

The following shows a hierarchical tree of the menu options, which are described in *Inverter Configuration Menu Options* on page 33:

```
C o u n t r y < G e r m a n y >
L a n g u a g e < e n g >
C o m m u n i c a t i o n
P o w e r C o n t r o l
D i s p l a y
M a i n t e n a n c e
I n f o r m a t i o n
```

Country:

```
G e r m a n y +
S p a i n
F r a n c e
I s r a e l
U n i t e d K i n g d o m
G r e e c e +
I t a l y
B u l g a r i a
C z e c h R e p u b l i c
B e l g i u m
N e t h e r l a n d s
P o r t u g a l
A u s t r i a
D e n m a r k +
S l o v e n i a
P o l a n d
A u s t r a l i a
S i n g a p o r e
T a i w a n
S r i L a n k a
M a u r i t i u s
L i t h u a n i a
```

Language:

```
E n g l i s h
G e r m a n
S p a n i s h
F r e n c h
I t a l i a n
```

Communication:

```
S e r v e r < L A N >
L A N C o n f
R S 4 8 5 - 1 C o n f < S >
Z i g B e e C o n f < S >
R S 2 3 2 C o n f
```



(Continued from previous page)

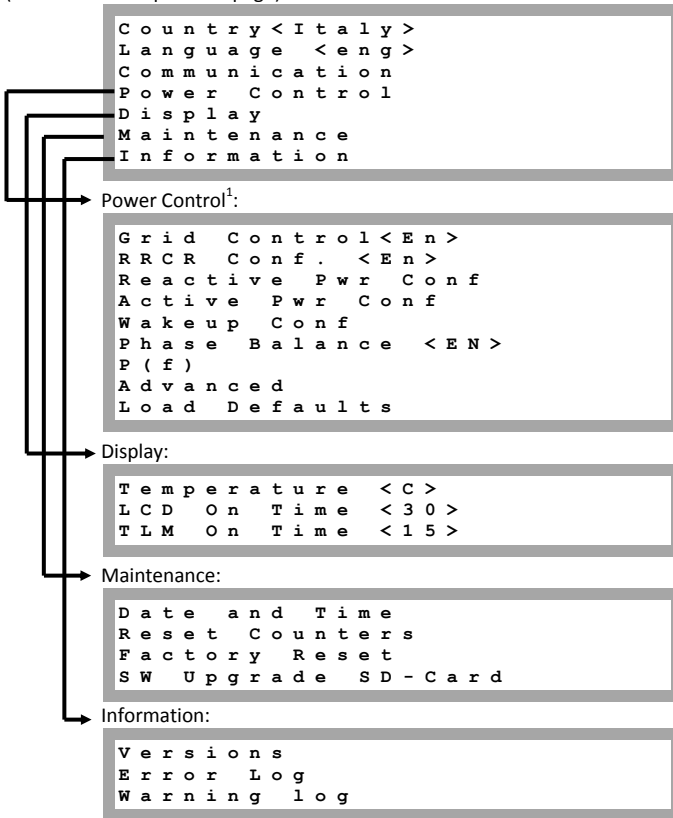

## Configuring the Inverter Using the External LCD Light Button

Use the LCD light button for communication setup and for displaying the Error log and Warning Log without having to open the inverter cover. There are fewer menus available when using this configuration option; however, the functionality is the same as when using the LCD User buttons.

- 1 Turn the inverter ON/OFF switch is to OFF.
- 2 Press and hold down the LCD light button until the following message is displayed:

```

Keep holding button
for pairing, release
to enter menu . . .
Remaining 3 sec
  
```

<sup>1</sup> Phase Balance is applicable to single phase inverters only.

Releasing the button displays the following menu:

```

O p t i m i z e r   p a i r i n g
L a n g u a g e   < e n g >
C o m m u n i c a t i o n
M a i n t e n a n c e
I n f o r m a t i o n
E x i t
  
```

- 3** Short-press (one second) to scroll down to the next menu option, and long-press (three seconds) to select the item. You can use the **Exit** options in these menus to move up one menu level or to exit the Setup mode from the main menu.

The following shows a hierarchical tree of the menu options that appear when using the LCD light button:

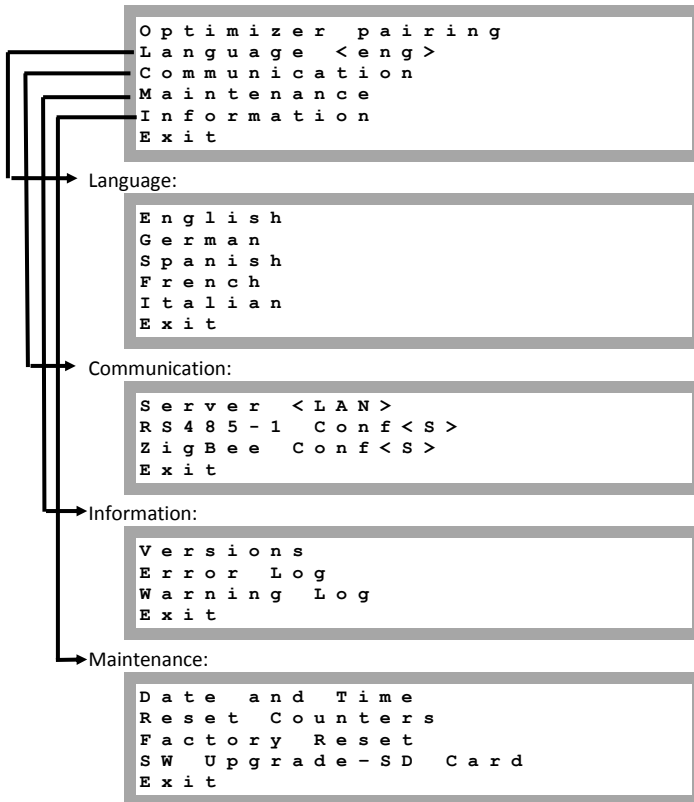

The options presented in these menus are described in the next section.

## Inverter Configuration Menu Options

This section describes how to use the LCD menus for configuring the inverter. Configuration is only available when the inverter ON/OFF switch is OFF. Use either the internal LCD user buttons or the external LCD light button to move between and select menu options.

### Country and Grid

Configuring the country and grid is available using the internal user buttons only.

- 1 Select the **Country** option to specify the country in which the inverter is installed and the grid to which it is connected. This parameter may arrive pre-configured. If so, verify that it is set to the proper country.



#### WARNING!

The inverter must be configured to the proper country in order to ensure that it complies with the country grid code and functions properly with that country grids.

A list of countries is displayed. If no country is configured, the value is <NONE>.



#### NOTE:

If an inverter is not configured to any country, it will not produce energy, and the following message will be displayed on the LCD: **No Country Selected**

A plus sign (+) near the country indicates that another menu is available for selecting grid options.

- 2 Confirm your country selection in the confirmation screen: Toggle to **YES** and press **Enter**.

### Language

- 1 Select the **Language** option to set the language in which the LCD should display.
- 2 Confirm your language selection in the confirmation screen: Toggle to **YES** and press **Enter**.

### Communication

- 1 Select the **Communication** option to define and configure the communication option used by the inverter to communicate with the SolarEdge monitoring portal and the communication option used to communicate between multiple inverters.
- 2 Select **Server** to set which communication method is used to communicate between the inverter and the SolarEdge monitoring portal. Refer to *Chapter 6: Setting Up Communication* on page 41 for a full description of these communication options.



#### NOTE:

This menu shows only the communication options installed in the inverter.

- 3 The following shows a hierarchical tree of the menu options in the **Communication** menu. For detailed information about all the configuration options, refer to the *Communication Options Application Note*, available on the SolarEdge website at [http://www.solaredge.com/files/pdfs/solaredge-communication\\_options\\_application\\_note\\_v2\\_250\\_and\\_above.pdf](http://www.solaredge.com/files/pdfs/solaredge-communication_options_application_note_v2_250_and_above.pdf).

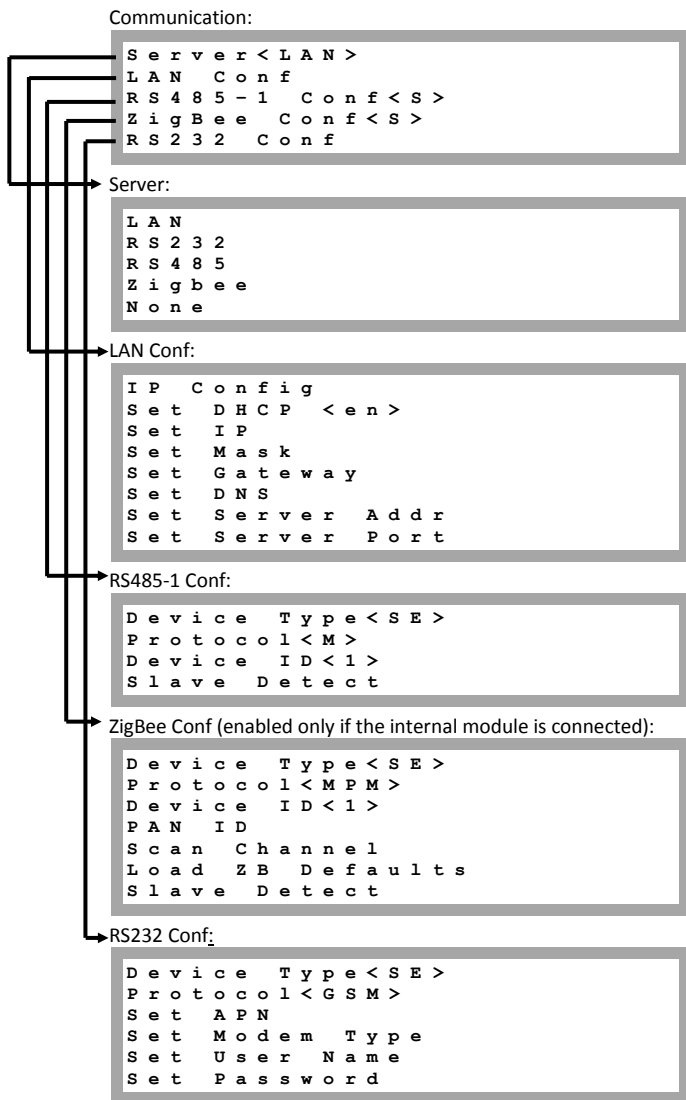

## Power Control

For detailed information about active and reactive power control options refer to the *Power Control Application Note*, available on the SolarEdge website at [http://www.solaredge.com/files/pdfs/application\\_note\\_power\\_control\\_configuration.pdf](http://www.solaredge.com/files/pdfs/application_note_power_control_configuration.pdf).

```
Grid Control < Dis >
RRCR Conf.
Phase Balance < EN >
Load Defaults
```

### NOTE:



**Phase Balance** is applicable to single phase inverters only. For detailed information, refer to the *SolarEdge Phase Balancing Manual*, available on the SolarEdge website at [http://www.solaredge.com/files/pdfs/phase\\_balancing\\_connection\\_guide.pdf](http://www.solaredge.com/files/pdfs/phase_balancing_connection_guide.pdf)

The Grid Control option is disabled by default. Enabling it opens additional options in the menu, as shown on page 31.

## Display

Select **Display** to set the following three options:

```
Temperature < F >
LCD On Time < 30 >
TLM On Time < 15 >
```

**Temperature:** Select Celsius or Fahrenheit units.

- **LCD On Time <30>**: The number of seconds that the LCD backlight is ON after pressing the LCD light button. Set a value within the range of 10-120 seconds.
- **TLM On Time <15>**: The number of minutes that the LCD backlight is ON while viewing the *Telemetry* window. Set a value within the range of 1-120 minutes.

## Maintenance

Select **Maintenance** to set the following options:

```
Date and Time
Reset Counters
Factory Reset
SW Upgrade - SD Card
```

- **Date and Time:** Set the internal real-time clock. If connected to the SolarEdge monitoring portal, the date and time are set automatically and only time zone should be set.
- **Reset Counters:** Reset the accumulated energy counters that are sent to the SolarEdge monitoring portal
- **Factory Reset:** Perform a general reset to the inverter default settings.
- **SW Upgrade SD Card:** Perform a software upgrade using an SD card.

## Information

Select **Information** to display the following options:

```
V e r s i o n s
E r r o r   L o g
W a r n i n g   l o g
```

- **Versions:** Displays inverter firmware versions :

```
I D :   # # # # # # # # # #
D S P 1 : 0 0 0 1 . 0 2 1 0 . 0 1 8 8
D S P 2 : 0 0 0 1 . 0 0 3 4 . 0 0 0 0
C P U : 0 0 0 2 . 0 0 3 7 . 0 0 0 0
```

- **ID:** The inverter ID.
- **DSP 1/2:** The DSP digital control board firmware version
- **CPU:** The communication board firmware version



### NOTE:

Please have these numbers ready when you contact SolarEdge support.

- **Error Log:** Displays the last five errors.
- **Warning Log:** Displays the last five warnings.

## Inverter Status Screens – Operational Mode

Pressing the external LCD light button turns on the LCD backlight. Additional presses display the following screens one after the other.

### Initial Inverter Status

```
V a c [ v ]   V d c [ v ]   P a c [ w ]
2 4 0 . 7     3 7 1 . 9     2 3 4 9 . 3
P _ O K :   X X X / Y Y Y   < S _ O K >
                O N
```

- **Vac [V]:** The AC output voltage.
- **Vdc [V]:** The DC input voltage.
- **Pac [W]:** The AC output power.
- **P\_OK: XXX/YYY:** There is a connection to the power optimizers and at least one power optimizer is sending monitoring data. XXX is the number of power optimizers for which telemetries have been received in the last two hours. YYY is the number of paired power optimizers identified during the most recent pairing process. If XXX and YYY are not equal, there may be a problem in one or more power optimizers.
- **S\_OK:** The connection to the SolarEdge monitoring portal is successful (appears only if the inverter is connected to the server).
- **ON/OFF:** Indicates the position of the inverter ON/OFF switch.

## Main Inverter Status

```
V a c [ v ]   V d c [ v ]   P a c [ w ]
2 4 0 . 7    3 7 1 . 9    3 2 1 0 . 0
F a c [ H z ]   O P s _ O k   T e m p
5 0 . 0       1 1         2 8 . 2
```

- **Vac [V]:** The AC output voltage.
- **Vdc [V]:** The DC input voltage.
- **Pac [W]:** The AC output power.
- **Fac[Hz]:** The AC output frequency.
- **OPs\_Ok:** Number of optimizers sending telemetries (indicating that they are paired)
- **Temp [C or F]:** The inverter's heat sink temperature

## Energy Meter Status

Displays the total energy produced during the last day, month, year and since inverter installation.

```
D a y [ W h ] :           0 . 0
M o n t h [ K W h ] :    0 . 0
Y e a r [ K W h ] :      0 . 0
T o t a l [ K W h ] :    0 . 0
```



### NOTE:

This data is accumulated according to an internal real-time clock.

## Telemetry Status

This window displays the last power optimizer telemetry received. The display changes as each power optimizer sends its telemetry.

In order to verify proper installation, the installer may view the Telemetry window for some time in order to observe the power optimizers report process.

```
M o d u l e :           0 0 0 C 1 E D 9 - 0 3
E n e r g y [ W h ] :    0
V d c _ O [ V ] :       4 0 . 5
V d c _ I [ V ] :       2 9 . 5
```

- **Module#:** Power optimizer serial number
- **Energy:** power optimizer energy
- **Vdc\_O:** Power optimizer output voltage
- **Vdc\_I:** Power optimizer input voltage (module voltage)

## ID Status

This window displays the inverter software version and the country to which the inverter is configured.

```
I D :   # # # # # # # # # #
D S P 1 / 2 : 1 . 0 2 1 0 / 1 . 0 0 3 4
C P U : 0 0 0 2 . 0 1 1 1
C o u n t r y :   U n i t e d   K i n g d o m
```

## Server Communication Status

```

S e r v e r : L A N           < S _ O K >
S t a t u s :                 < O K >
                               x x x x x x x x
< E R R O R   M E S S A G E >

```

- **Server:** The method of connection to the SolarEdge monitoring portal
- **S\_OK:** The connection to the SolarEdge monitoring portal is successful (should appear only if the inverter is connected to the server).
- **Status:** Displays OK if the inverter established a successful connection and communication with the specified server port/device (LAN, RS485 or ZigBee module).
- **xxxxxxx:** Eight-bit Ethernet communication connection status: A string of 1s and 0s is displayed. 1 indicates OK, 0 indicates an error. For a list of the possible errors and how to troubleshoot them, refer to *Troubleshooting Communication* on page 50.
- **Error message,** according to failure  
Refer to *Troubleshooting Communication* on page 50 for detailed information.

## IP Status

This window describes the Ethernet configuration: IP, Mask, Gateway and MAC address (Media Access Control) of the inverter.

```

I P       1 9 2 . 1 6 8 . 2 . 1 1 9
M S K     2 5 5 . 2 5 5 . 2 5 5 . 0
G W       1 9 2 . 1 6 8 . 2 . 1
M A C     0 - 2 7 - 0 2 - 0 0 - 3 9 - 3 6

```

## ZigBee Status

This window describes the ZigBee configuration:

```

P A N : X X X X X
C h : X X / X X X X   R S S I : < L >
I D : X X X X X X X X
M I D : X X X X   X X

```

- **RSSI:** The receive signal strength indication of the closest ZigBee in the SolarEdge system. L = low, M = medium, H = high and (-) = no signal.
- **PAN ID:** The ZigBee transceiver pan ID
- **Ch.:** The ZigBee transceiver channel
- **ID:** The ZigBee transceiver ID
- **MID:** The Master ID of the coordinator (master) ZigBee module. This field is shown only in devices with router (slave) ZigBee modules. This field appears after a successful ZigBee association. If a ZigBee module is not connected, a *No ZigBee* message is displayed instead of the **MID** field.



## Communication Ports Status

```

      D e v   P r o t   # #
R S 4 8 5 - 1 < S E > < S > < - - >
Z i g B e e   < S E > < M P S > < - - >

```

- **##**: The total number of slaves detected on the specific port
- **DEV**: The type of device that was configured to a specific port (based on the port's functionality), as follows:
  - **SE**: SolarEdge device (default)
  - **MTR**: Revenue meter
  - **LGR**: Non-SolarEdge logger
- **PROT**: The protocol type to which the port is set:
  - For a SolarEdge device:
    - **S**: SolarEdge slave
    - **M**: SolarEdge master
    - **P2P**: ZigBee point-to-point
    - **MPM**: ZigBee multipoint master (for a ZigBee coordinator module)
    - **MPS**: ZigBee multipoint slave (for a ZigBee router module)
  - For a *revenue meter* reader, refer to the supported revenue meters page at <http://www.solaredge.com/articles/se-supported-devices>.
  - **SS**: SunSpec - for a non-SolarEdge logger

## Fan Health Status – Three Phase Inverters

This window provides information about the status of the inverter's two fans:

```

F a n # 1 :   R e p l a c e
F a n # 2 :   O p e r a t i n g

```

Each fan can have one of the following statuses:

- Operating: Fan OK
- **Not Working**: This status may indicate a system error and not necessarily a faulty fan. Turning AC OFF and ON again may clear this status. If the status does not change, replace the fan.
- **Replace**: This status indicates a faulty fan that requires replacement
 

When a fan has the status **Replace**:

  - The display blinks constantly (but not when the inverter is in night mode) until the fan is replaced.
  - An error appears that the fan is faulty (refer to *Appendix A: Errors and Troubleshooting* on page 50).
  - The Fault LED is not lit.

For more information, refer to *Fan 2 Replacement* on page 68 .

## Power Control Status

Appears only if Power Control is enabled.

P	C	o	n	t	r	o	l	:		G	E	R
P	e	a	k		P	o	w	e	r	:		0 %
P	F	:										+ 1 . 0 0
A	C		P	o	w	e	r	:				0 W

- **P Control:** Specifies the country according to which power control is done.
- **Peak Power:** Specifies the ratio between the power the inverter can output and the inverter's maximum AC power. If active power is limited (either using the RRCR option or using the Active Power Limit option), the limit will be displayed here.
- **PF:** Power Factor. Specifies the CosPhi corresponding to the ratio between active and reactive power
- **AC Power:** Specifies the AC power that the inverter is currently producing.

For more information, refer to the *Power Control Application Note*, available on the SolarEdge website at [http://www.solaredge.com/files/pdfs/application\\_note\\_power\\_control\\_configuration.pdf](http://www.solaredge.com/files/pdfs/application_note_power_control_configuration.pdf).

# Chapter 6: Setting Up Communication

Power optimizers send information to the inverter via the DC power lines (the PV output circuit). No additional wires or configurations are required for this purpose. The information is then sent from the inverter to the SolarEdge monitoring portal through the Internet. In order to send the data from the inverter, a communication connection must be set up, as described in this chapter. Communication setup is not required for power harvesting and is needed only for using the SolarEdge monitoring portal.

This chapter also describes setting up communication between multiple inverters for a master/slave configuration.



**CAUTION:**

When connecting the communication cables, make sure that the ON/OFF switch at the bottom of the inverter is turned OFF, and the AC is turned OFF.

When configuring the communication parameters, make sure that the ON/OFF switch is OFF, and the AC is turned ON.

## Communication Connectors

Two communication glands are used for connection of the various inverter communication options. Each gland has three openings. The table below describes the functionality of each opening. Unused openings should remain sealed.

Gland#	Opening	Functionality	Cable Size (diameter)
1 (PG16)	One small	External antenna cable	2-4 mm
	Two large	Ethernet connection (CAT5/6) or RS232	4.5-7 mm
2 (PG13.5)	All three	RS485, power reduction	2.5-5 mm

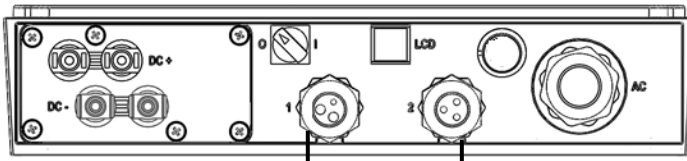

Figure 14: Communication Glands

Two types of communication boards are available, different in the Ethernet connector: one with an 8-pin terminal block connection and the other with a standard RJ45 Ethernet connector, as shown below:

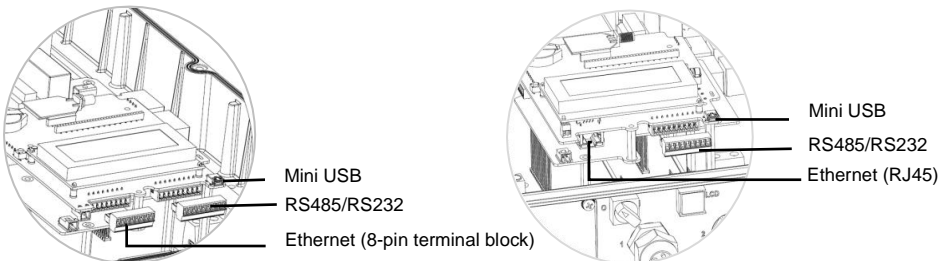

Figure 15: Internal Connectors

## Communication Types

- **Ethernet:** page 42, used for a LAN connection
- **RS485:** page 45, the most commonly used communication type, used for the connection of multiple SolarEdge devices on the same bus in a master-slave configuration. RS485 type can also be used as an interface to external non-SolarEdge devices, such as revenue meters and data loggers.
- **RS232 (UART):** page 48, enables connection to an external SolarEdge GSM modem for connection to the SolarEdge monitoring portal.
- **ZigBee:** page 49, optional wireless communication (purchased separately)
- **USB:** page 49, enables connection of a laptop to the inverter

## Removing the Inverter Cover

If the cover is not already removed (for example, during initial installation, while AC is still not connected), use the following procedure for cover removal for communication connections purposes.

- 1 Turn the inverter ON/OFF switch to OFF.
- 2 Disconnect the AC to the inverter by turning OFF the circuit breakers on the distribution panel. Wait 5 minutes for the capacitors to discharge.
- 3 Open the inverter cover's six Allen screws and carefully pull the cover vertically before lowering it.



### CAUTION:

When removing the cover, make sure not to damage internal components. SolarEdge will not be held responsible for any components damaged as a result of incautious cover removal.

## Creating an Ethernet (LAN) Connection

This communication option enables using an Ethernet connection to connect the inverter to the monitoring portal through a LAN.

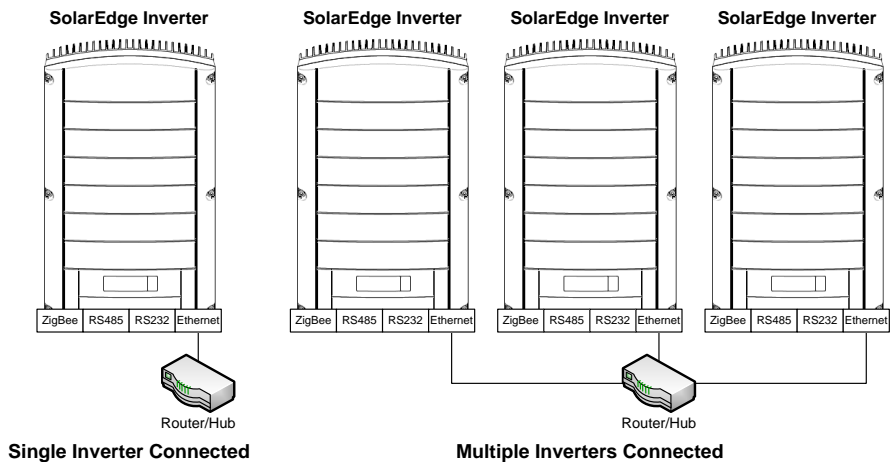

Figure 16: Example of Ethernet connection

- 1 Remove the inverter cover as described in *Removing the Inverter Cover* on page 42.

- 2 Open gland #1.
- 3 Remove the plastic seal from the large opening that has a cut in the rubber fitting and insert an Ethernet CAT5/6 cable through the opening.



**CAUTION:** The internal side of the gland includes a rubber waterproof fitting, which should be used to ensure proper sealing.

CAT5/6 standard cables have eight wires (four twisted pairs), as shown in the diagram below. Wire colors may differ from one cable to another. You can use either wiring standard, as long as both sides of the cable have the same pin-out and color-coding.

RJ45 Pin #	Wire Color <sup>1</sup>		10Base-T Signal 100Base-TX Signal
	T568B	T568A	
1	White/Orange	White/Green	Transmit+
2	Orange	Green	Transmit-
3	White/Green	White/Orange	Receive+
4	Blue	Blue	Reserved
5	White/Blue	White/Blue	Reserved
6	Green	Orange	Received-
7	White/Brown	White/Brown	Reserved
8	Brown	Brown	Reserved

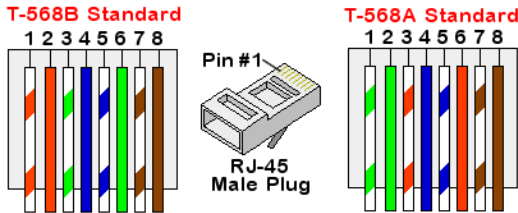
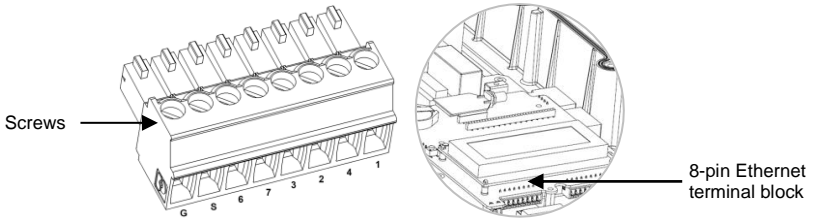

Figure 17: Standard cable wiring

<sup>1</sup> The inverter connection does not support RX/TX polarity change. Supporting crossover Ethernet cables depends on the switch capabilities.

**4** Depending on the inverter connector type (RJ45 or an 8-pin terminal block), Connect as follows:

- If the inverter has an 8-pin terminal block connector for Ethernet communication:
  - Pull the connector out, as shown below:



**Figure 18: The 8-pin Ethernet terminal block**

- Loosen the screws, except for that of pin G. Insert the ends of the wires into the pins according to the following table:

Terminal Block Pin #	RJ45 Pin #	Color	
		T568B Standard	T568A Standard
1	1	White/Orange	White/Green
2	2	Orange	Green
3	3	White/Green	White/Orange
4	4 and 5	Blue + White/Blue	Blue + White/Blue
6	6	Green	Orange
7	7 and 8	Brown + White/Brown	Brown + White/Brown
S	Aluminum shield		
G-unconnected			

- Tighten the screws of the Ethernet terminal block.
- Check that the wires are fully inserted and cannot be pulled out easily. Push the Ethernet terminal block firmly all the way into the Ethernet connector on the communication board.
- If the inverter has an RJ45 connector for Ethernet communication, use a pre-crimped cable to connect via gland no.1 to the RJ45 plug on the inverter's communication board, or, if using a cable drum, connect as follows:
  - Insert the cable through gland no.1.
  - Remove the cable's external insulation using a crimping tool or cable cutter and expose eight wires.
  - Insert the eight wires into an RJ45 connector, as described in Figure 17.
  - Use a crimping tool to crimp the connector.

- Connect the Ethernet connector to the RJ45 plug on the inverter's communication board.

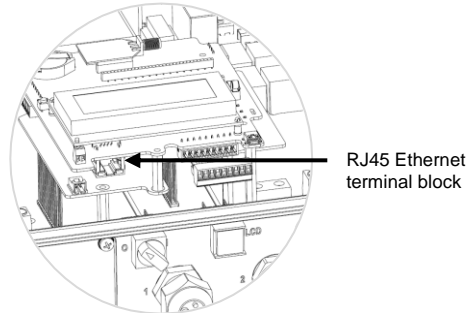

**Figure 19: The RJ45 Ethernet connector**

- 5 For the switch/router side, use a pre-terminated cable or use a crimper to prepare an RJ45 communication connector: Insert the eight wires into the RJ45 connector in the same order as in Figure 17.
- 6 Connect the cable's RJ45 connector to the RJ45 port of the Ethernet switch or router. You can connect more than one inverter to the same switch/router or to different switches/routers, as needed. Each inverter sends its monitored data independently to the SolarEdge monitoring portal.
- 7 Inverters are configured by default to **LAN**. If reconfiguration is required:
  - Make sure the ON/OFF switch is OFF.
  - Turn ON the AC to the inverter by turning ON the circuit breaker on the main distribution panel.



**WARNING!**

ELECTRICAL SHOCK HAZARD. Do not touch uninsulated wires when the inverter cover is removed.

- Use the user buttons to configure the connection, as described in *Communication* on page 33.



**NOTE:**

If your network has a firewall, you may need to configure it to enable the connection to the following address:

- Destination Address: prod.solaredge.com
- TCP Port: 22222 (for incoming and outgoing data)

- 8 Verify the connection, as described in *Verifying the Connection* on page 48.

## Creating an RS485 Bus Connection

The RS485 option enables creating a bus of connected inverters, consisting of up to 31 slave inverters and 1 master inverter. Using this option, inverters are connected to each other in a bus (chain), via their RS485 connectors. The first and last inverters in the chain must be terminated.

The following sections describe how to physically connect the RS485 bus and how to configure the bus.

### ▶ To connect the RS485 communication bus:

- 1 Remove the inverter cover as described in *Removing the Inverter Cover* on page 42.
- 2 Remove the seal from one of the openings in communication gland #2 and insert the wire through the opening.

- 3 Pull out the 9-pin RS485/RS232 terminal block connector, as shown below:

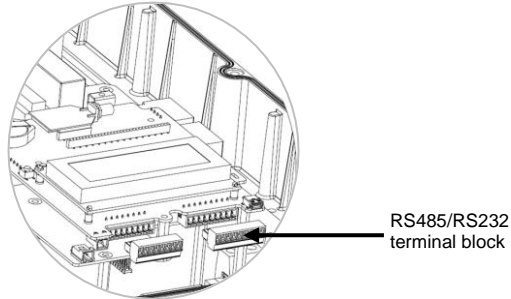

Figure 20: The RS485/RS232 terminal block

- 4 Loosen the screws of pins **A(+)**, **B(-)**, and **G** on the left of the RS-485 terminal block.

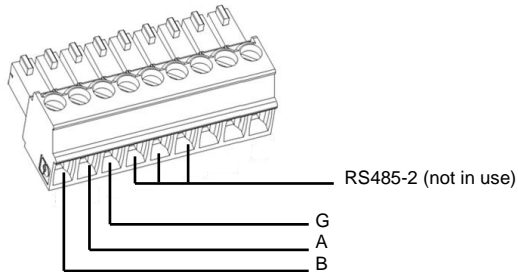

Figure 21: RS485/RS232 terminal block

- 5 Insert the wire ends into the **G**, **A** and **B** pins shown above. Use Four- or six-wire twisted pair cable for this connection. You can use any color wire for each of the **A**, **B** and **G** connections, as long as the same color wire is used for all A pins, the same color for all B pins and the same color for all G pins.
- 6 Connect all B, A and G pins in all inverters. The following figure shows this connection schema:

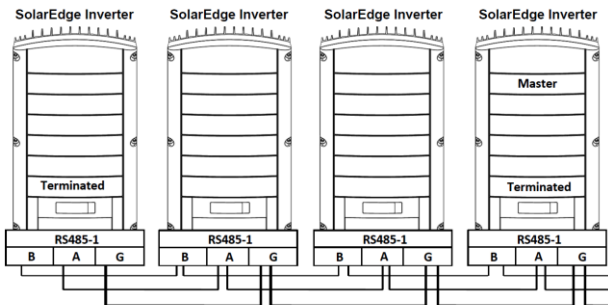

Figure 22: Connecting the inverters in a chain



**NOTE:**

Do not cross-connect **B**, **A** and **G** wires. Do not insert wires into RS485-2 pins.



- 7 Tighten the terminal block screws.
- 8 Check that the wires are fully inserted and cannot be pulled out easily.
- 9 Push the RS485 terminal block firmly all the way into the connector on the right side of the communication board.
- 10 Terminate the first and last SolarEdge device (inverter/SMI/Control and communication gateway, etc.) in the chain by switching a termination DIP-switch inside the inverter to ON (move the switch up). The switch is located on the communication board and is marked **SW7**.

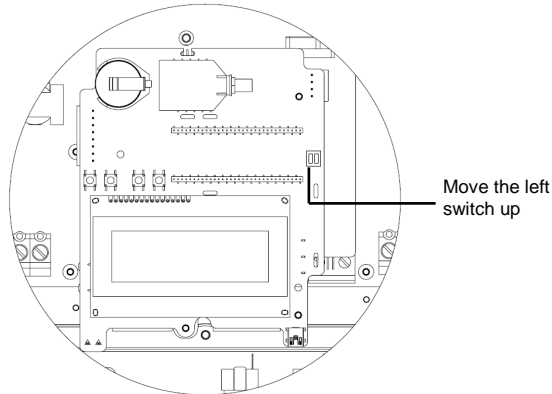

Figure 23: RS485 termination switch



**NOTE:**

Only the first and last SolarEdge devices in the chain should be terminated. The other inverters in the chain should have the termination switch OFF (down position).

▶ **To connect to the monitoring portal:**

- 1 Designate a single inverter as the connection point between the RS485 bus and the SolarEdge monitoring portal. This inverter will serve as the master inverter.
- 2 Connect the master to the SolarEdge monitoring portal via the LAN or GSM modem communication option.

▶ **To configure the RS485 communication bus:**

All inverters are configured by default as slaves. If reconfiguration is required:

- 1 Make sure the ON/OFF switch is OFF.
- 2 Turn ON the AC to the inverter by turning ON the circuit breaker on the main distribution panel.



**WARNING!**

ELECTRICAL SHOCK HAZARD. Do not touch uninsulated wires when the inverter cover is removed.

- 3 Use the user buttons to configure the connection, to configure the inverter designated as master, select the following in the LCD menus:
  - Communication → Server → LAN or RS232
  - RS485-1 Conf. → Device Type → SolarEdge
  - RS485-1 Conf. → Protocol → Master
  - RS485-1 Conf. → Slave Detect

The system starts automatic detection of the SolarEdge slave inverters connected to the master inverter. The inverter should report the correct number of slaves. If it does not, verify the connections and terminations.

- 4 Verify the connection of the master to the SolarEdge monitoring portal, as described in *Verifying the Connection* on page 49.

## Creating an RS232 (UART) Connection

This communication option enables connecting the inverter via a GSM modem available for purchasing at SolarEdge. The modem is provided with its own user manual, which should be reviewed.

### ▶ To connect a GSM modem to the inverter:

- 1 Remove the inverter cover as described in *Removing the Inverter Cover* on page 42.
- 2 Remove the seal from one of the large openings in communication gland #1 and insert the cable supplied with the GSM kit through the opening.
- 3 Pull out the 9-pin RS485/RS232 terminal block connector, as shown below:

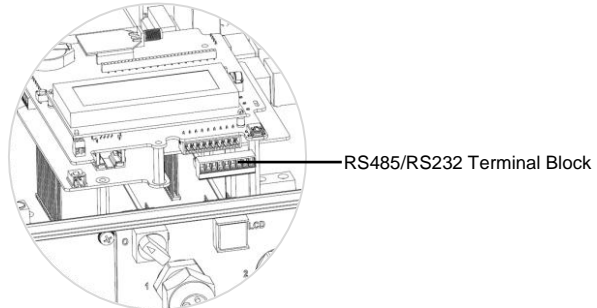

Figure 24: RS485/RS232 9-pin terminal block

- 4 Loosen the screws of pins **TX**, **RX**, and **G** on the right of the 9-pin terminal block.

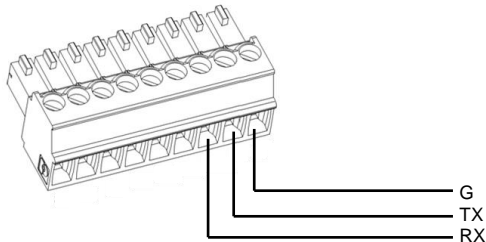

Figure 25: RS485/RS232 terminal block

- 5 Insert the wire ends into the G, TX and RX pins shown above.
- 6 Tighten the terminal block screws.
- 7 Push the RS485/RS232 terminal block firmly all the way into the communication board.
- 8 Connect the other end of the RS232 cable to the GSM modem.
- 9 Connect the power supply to the modem and to an electrical socket.

- 10** To configure the RS232 communication, refer to the *Cellular Modem Installation Guide* available on the SolarEdge website at: [http://www.solaredge.com/files/pdfs/se\\_application\\_gsm.pdf](http://www.solaredge.com/files/pdfs/se_application_gsm.pdf)
- 11** Verify the connection of the master to the SolarEdge monitoring portal, as described in *Verifying the Connection* on page 49.

## Creating a ZigBee Connection

This communication option enables using a ZigBee connection for one of the following:

- To connect the inverter to the SolarEdge monitoring portal
- To create a master/slave bus of connected inverters

The ZigBee device is purchased separately and provided with a user manual, which should be reviewed prior to connection. It is available on the SolarEdge website at <http://www.solaredge.com/groups/products/accessories> (under ZigBee)

## Connecting a Laptop to the Inverter

To connect a laptop to the inverter, use the internal mini-USB connector (type B 5-pin) located on the inverter communication board (see Figure 15 on page 41).

The USB port uses a standard USB driver that can connect to any standard PC or laptop with a Windows operating system. If the USB connection is not recognized, install a USB driver, downloadable directly from the manufacturer website at <http://www.ftdichip.com/Drivers/VCP.htm>.

## Verifying the Connection

- 1** Close the inverter cover (see also page 23).
- 2** Turn ON the AC to the inverter by turning ON the circuit breaker on the main distribution panel.
- 3** Wait for the inverter to connect to the SolarEdge monitoring portal. This may take up to two minutes.

A status screen similar to the following appears on the LCD panel:

```

V a c [ v ]   V d c [ v ]   P a c [ w ]
2 4 0 . 7     5 . 2 v       0 . 0
                < S _ O K >
                O F F
  
```

**S\_OK:** Indicates that the connection to the SolarEdge monitoring portal is successful. If S\_OK is not displayed, refer to *Appendix A: Errors and Troubleshooting* on page 50

## Appendix A: Errors and Troubleshooting

This appendix describes the error messages that appear on the inverter LCD panel when an error occurs, and how to troubleshoot them.

### Troubleshooting Communication - S\_OK is Not Displayed

If S\_OK is not displayed, perform the following:

#### ► To troubleshoot Ethernet communication:

When Ethernet communication is used, the *Server Communication Status* window, as described on page 39, can be used to identify the location of the error.

```

S e r v e r : L A N           < S _ O K >
S t a t u s :                 < O K >
                               x x x x x x x x
< E r r o r   M e s s a g e >
  
```

xxxxxxx is a string of 1s and 0s showing an eight-bit communication connection status. 1 indicates OK and 0 indicates an error. The possible errors and their troubleshooting are detailed in the following table:

Bit Location	Error Message	Error Description	Troubleshooting
1st	LAN Disconnected	An Ethernet physical cable connection fault: The Ethernet link or physical Ethernet cable are not connected properly	Check the cable pin-out assignment and cable connection. Refer to <i>Creating an Ethernet (LAN) Connection</i> on page 42
2nd	DHCP Failed, or Invalid DHCP Config	The inverter failed to get a valid IP address from the DHCP server, or The DHCP/static IP settings in the gateway are not the same as those of the router.	Check the router and inverter configuration. Consult your network IT.
3rd	Gateway Ping Failed	The connection to the router is not available: Ping to the first local switch/router failed (LAN error)	Check the physical connection to the switch/router. Check that the link LED at the router /switch is lit (indicating phy-link). If OK - contact your network IT, otherwise replace the cable or change it from cross to straight connection
4th	G Server Ping Failed	The connection to the Internet is not available: Ping to google.com failed	Connect a laptop and check for internet connection. If internet access is unavailable, contact your IT admin or your internet provider. For WIFI networks, ensure that username and password are as defined in the internet provider AP/router.
5th	Server x Ping Failed	Ping to redundant server #x failed	Check the SolarEdge server address, under LAN Conf submenu <ul style="list-style-type: none"> <li>▪ Address: prod.solaredge.com</li> <li>▪ Port: 22222</li> </ul> Check with your network administrator whether a firewall or another device is blocking transmission
6th			
7th			
8th	Tcp Connect. Failed	The connection to the SolarEdge server was not established: Communication with the server failed	

▶ **To troubleshoot RS485 communication:**

- 1 If after a successful slave detection, the number of slaves reported in the master is smaller than the actual number of slaves, check the Server Communication status screen of every slave inverter. The following should appear:

```
S e r v e r : R S 4 8 5
S t a t u s :           O K
```

- 2 If **Master Not Found** message appears, the master device is not responsive or the RS485 cable is not connected. Check the connections to the master device and fix if required.

▶ **Additional troubleshooting:**

- 1 Check that the modem or hub/router is functioning properly.
- 2 Check that the connection to the internal connector on the communication board is properly done.
- 3 Check that the selected communication option is properly configured.
- 4 Use a method independent of the SolarEdge inverter to check whether the network and modem are operating properly. For example, connect a laptop to the Ethernet router and connect to the Internet.
- 5 Check whether a firewall or another type of network filter is blocking communication.
- 6 For ZigBee troubleshooting, refer to the ZigBee installation manuals.

## Error Codes

The error code numbers may differ depending on the inverter type (single phase or three phase) as described in the table below.

The error messages include an error number and a description, and have the following format:

```

E r r o r   c o d e   x x x
x x x x x x x x x x x x x x x x x x x x
x x x x x x x x x x x x x x x x x x x x
    
```

An error message is displayed for 30 seconds, after which the inverter waits the necessary reconnection time and then restarts. During this time, the LCD displays the Waking Up message and the remaining time to reconnection.



**WARNING!**  
All Warnings and Cautions in this manual should be adhered to while troubleshooting an error.

Error # Single Phase	Error # Three Phase	LCD Message	Description	Troubleshooting
N/A	1-4	Fan # Failure	One of the fans is not working	Check the <i>Fan Health Status – Three Phase Inverters</i> on page 39. If required, replace the fan (a replacement kit is available from SolarEdge).
4, 5, 8, 12, 18-23, 39, 42, 45	45, 48, 50-53, 94, 108-111, 113	SW Error	Internal software error	If the fault persists, contact SolarEdge support.
N/A	112	Wrong AC connection	The lines connections to the inverter are incorrect, for example: AC line 1 from the grid is connected to line 2 at the inverter so there is no 120deg between L2 to L1 and L3 to L2 at the inverter side.	Switch between L1 and L2 or L2 and L3 connections
9, 13	N/A	AC Current Surge	The internal hardware that measures AC current has measured substantially high output currents. This may occur because of changes in the AC voltage or a switching load near the site.	If the fault persists: <ul style="list-style-type: none"> <li>■ Check the AC connection to the inverter.</li> <li>■ Check with the grid operator if a large surge source or irregular load exists near the site.</li> <li>■ If the grid does not have problems contact SolarEdge support.</li> </ul>

Error # Single Phase	Error # Three Phase	LCD Message	Description	Troubleshooting
10, 37, 38	76, 77, 90	Ground Current - RCD	Ground current surge. The internal hardware that measures ground fault has measured substantially high ground currents.	<p>Ground faults may occur due to insufficient insulation to the ground.</p> <p><b>WARNING!</b></p> <p> <b>ELECTRICAL SHOCK HAZARD.</b> Do not touch uninsulated wires when the inverter cover is removed. Extreme care must be taken when troubleshooting this error. Only a qualified technician should handle this problem, and only after taking proper precautions.</p> <ol style="list-style-type: none"> <li><b>1</b> Turn the inverter ON/OFF switch to OFF.</li> <li><b>2</b> Wait five minutes for the input capacitors to discharge.</li> <li><b>3</b> Disconnect the AC breaker.</li> <li><b>4</b> Disconnect the DC inputs.</li> <li><b>5</b> Connect each DC string separately, turn the AC and the inverter ON/OFF switch to ON, until the error appears for the faulty string.</li> </ol> <ul style="list-style-type: none"> <li>▪ Do not connect strings with a grounding fault to the inverter.</li> <li>▪ For further documentation about possible ground current error sources and solutions contact SolarEdge support.</li> <li>▪ A certified installer must fix the faulty string before connecting it to the inverter.</li> </ul>
14	58/59/60	AC Voltage Too High (Line 1/2/3)	AC voltage surge. The internal hardware that measures AC voltage has measured substantially high sudden output voltage.	<p>If the fault persists:</p> <ul style="list-style-type: none"> <li>▪ Check the AC connection to inverter.</li> <li>▪ Verify that the inverter is set to the correct country.</li> <li>▪ Check with the grid operator if a large surge source or irregular load exists near the site.</li> <li>▪ Verify that the output wire size matches the distance between the inverter and the location of the grid connection.</li> <li>▪ Use a larger gauge wire for the AC output.</li> <li>▪ Refer to the <i>AC Wiring Application Note</i>, available on the SolarEdge website at <a href="http://www.solaredge.com/files/pdfs/application-note-recommended-wiring.pdf">http://www.solaredge.com/files/pdfs/application-note-recommended-wiring.pdf</a></li> </ul>

Error # Single Phase	Error # Three Phase	LCD Message	Description	Troubleshooting
15	102	DC Voltage Too High	DC overvoltage. The input DC voltage exceeds the maximum supported level.	<p>The SolarEdge system normally eliminates DC overvoltage errors: When DC overvoltage is detected, the inverter shuts off the power optimizers and restarts.</p> <p>If the fault persists:</p> <ul style="list-style-type: none"> <li>▪ Turn OFF the inverter ON/OFF switch. If after five minutes, the LCD panel does not show a low safety voltage (1V per optimizer), check which string is malfunctioning, and recheck its connections to the inverter.</li> <li>▪ Proceed according to Power Optimizers Troubleshooting on page 57</li> <li>▪ Re-commission all inverters in the site, as described in <i>Chapter 4: Commissioning the Installation</i> on page 23.</li> </ul>
16	123	Measurement Error	Internal hardware error.	If the fault persists, contact SolarEdge support.
17	104	Temperature Too High	Over temperature.	<p>If the fault persists:</p> <ul style="list-style-type: none"> <li>▪ Verify that proper clearances exist around the inverter.</li> <li>▪ Make sure that the heat-sink fins are clear of dirt and obstacles.</li> <li>▪ Reinstall in a cooler location.</li> </ul>
24	N/A	Faulty Temp. Sensor	Broken or unconnected Temperature sensor.	If the fault persists, contact SolarEdge support.
25	121	Isolation Fault	PV Isolation fault. The inverter has detected the PV solar array is not properly isolated from ground earth. The isolation is checked each time the inverter starts up.	<p>If the fault persists:</p> <ul style="list-style-type: none"> <li>▪ Check the PV installation for isolation problems and ground leakage.</li> <li>▪ Only a certified PV installer must fix the faulty string before connecting it to the inverter.</li> </ul>
26	122	Faulty AC Relay	The AC relay failed during wake-up tests.	<p>If the fault persists:</p> <ul style="list-style-type: none"> <li>▪ Disconnect inverter from AC grid.</li> <li>▪ Contact SolarEdge support.</li> </ul>
27	95, 106, 120, 125, 126	Measurement Error	Internal hardware error.	If the fault persists, contact SolarEdge support.
28	N/A	RCD Sensor Error	The RCD measurement has failed during the wake-up test phase.	If the fault persists, contact SolarEdge support.



Error # Single Phase	Error # Three Phase	LCD Message	Description	Troubleshooting
29-30	N/A	Phase Balance Error	The monitoring hardware that checks the balance of each phase (L1-N and L2-N) has exceeded allowed limit.	<ul style="list-style-type: none"> <li>▪ Check the grid connection.</li> <li>▪ Check the GND wire connection.</li> <li>▪ Check the L1, L2 and Neutral wire connections.</li> <li>▪ Verify symmetric load between L1 and L2.</li> <li>▪ Consult the local grid authority.</li> </ul>
31, 33	64/65/66	AC Voltage Too High (Line 1/2/3)	Grid voltage is above the limit permitted in this country.	<ul style="list-style-type: none"> <li>▪ Verify that the inverter is set to the correct country.</li> <li>▪ Turn OFF the inverters in the site and verify AC grid voltage.</li> <li>▪ If the inverter is located far from the connection point to the grid, use a larger gauge AC wire.</li> <li>▪ Consult the grid operator.</li> <li>▪ If permitted by local authorities, use the SolarEdge Configuration Tool to change the settings.</li> </ul>
32, 41	61/62/63, 67/68/69	AC Voltage Too Low	Grid Voltage is below the limit permitted in this country.	<ul style="list-style-type: none"> <li>▪ Verify that the inverter is set to the correct country.</li> <li>▪ Consult the grid operator.</li> <li>▪ If permitted by local authorities, use the SolarEdge Configuration Tool to change the settings.</li> </ul>
34	79/80/81	AC Freq Too High (Line 1/2/3)	Grid frequency is above the limit permitted in this country.	Handle this in the same manner as error 32.
35	82/83/84	AC Freq Too Low (Line 1/2/3)	Grid frequency is below the limit permitted in this country.	Handle this in the same manner as error 32.
36	72/74/75	DC Injection (Line 1/2/3)	DC feed detected on the AC output.	If the fault persists, contact SolarEdge support.
40	N/A	Islanding	AC grid voltage is out of range. The inverter has shut off due to islanding.	When AC voltage returns, the inverter should restart after the reconnection time, which depends on country grid connection codes. If the problem persists, consult with the grid operator whether frequent AC disruptions have occurred at the site.
43	N/A	Isolation Fault	Internal hardware error.	If the fault persists, contact SolarEdge support.
44	44	No Country Selected	The inverter is not configured to any country.	Select the country, as described on page 33.

Error # Single Phase	Error # Three Phase	LCD Message	Description	Troubleshooting
46		Phase Unbalance	Uneven power supply in three inverters	Change the <b>Phase Balance</b> option in the Inverter's LCD menu to <b>Disable</b> . Refer to <i>Power Control</i> on page 35 and to the <i>SolarEdge Phase Balancing Manual</i> , available on the SolarEdge website at <a href="http://www.solaredge.com/files/pdfs/phase_balancing_connection_guide.pdf">http://www.solaredge.com/files/pdfs/phase_balancing_connection_guide.pdf</a>
N/A	103, 146	DC Voltage Too Low / UDC Min	The input DC voltage is below the minimum level that is supported.	Turn the inverter OFF and then ON. If this fault persists, contact SolarEdge support.
N/A	49	SE Communication	Internal software error.	If this fault persists, contact SolarEdge support.
N/A	78	Grid Sync Error	Grid voltage or frequency is unstable.	If this fault persists, contact SolarEdge support.
N/A	91/92/93, 96/97/98	AC Over Current Line 1/2/3	Grid error.	If this fault persists, contact SolarEdge support.
N/A	99-101	AC Voltage Too High Line 1/2/3	Grid error.	Turn the inverter OFF and then ON. If this fault persists, contact SolarEdge support.
N/A	105	Temperature Too Low	Under temperature.	If this fault persists, reinstall the inverter in a warmer place.
N/A	124	Ground Current – RCD	Internal hardware error.	If this fault persists, contact SolarEdge support.

## Power Optimizers Troubleshooting

Problem	Possible Cause	Possible Solution
String voltage is 0V	Output of one or more power optimizers is disconnected	Connect all power optimizer outputs
String voltage not 0V but lower than the number of optimizers	One or more of the power optimizers are not connected in the string	Connect all power optimizers
	One or more of the modules are not connected properly to their power optimizer inputs	Connect the modules to the optimizer inputs
	Wrong polarity connection on one of the strings	Check polarity of the string output using a voltmeter and correct if needed.
String voltage is higher than the number of optimizers	One or more extra power optimizers are connected in the string	Check if an extra power optimizer is connected in the string. If not – proceed to next solution.
<p><b>WARNING!</b></p>  <p>If the measured voltage is too high, the installation may not have a safe low voltage. <b>PROCEED WITH CARE!</b> A deviation of <math>\pm 1\%</math> per string is reasonable.</p>	A module is connected directly to the string, without a power optimizer.	Verify that only power optimizers are connected in the string and that no module outputs are connected without a power optimizer. If the problem persists, proceed to the next step.
	A malfunction of one of the power optimizers	<ul style="list-style-type: none"> <li>▪ Disconnect the wires that connect the power optimizers in the string.</li> <li>▪ Measure the output voltage of each power optimizer in order to locate the power optimizer that does not output the 1V safety voltage.</li> <li>▪ If a malfunctioning power optimizer is located, check its connections, polarity, module, and voltage.</li> <li>▪ Do not continue before finding the problem and replacing the malfunctioning power optimizer.</li> <li>▪ If a malfunction cannot be bypassed or resolved, skip the malfunctioning power optimizer, thus connecting a shorter string.</li> </ul>
	SafeDC mode was previously disabled using the SolarEdge Key	Enable the SafeDC using the SolarEdge Key
Pairing to the inverter failed	The power optimizers are shaded	If you connected the inverter to the SolarEdge monitoring portal using one of the communication options, you can perform pairing remotely. Before leaving the site, make sure that the inverter ON/OFF switch is ON and S_OK indication appears on the LCD to indicate connection to the monitoring portal.

# Appendix B: Technical Specifications

## Single Phase Inverters

	SE2200	SE3000	SE3500	SE4000	SE4000-16A	SE5000	SE6000	Unit
<b>Output</b>								
Rated AC power output	2200	3000	3500	4000	4000	5000 <sup>1</sup>	6000	W
Maximum AC power output	2200	3000	3500	4000	4000	5000 <sup>1</sup>	6000	W
AC output voltage (nominal)	220/230							Vac
AC output voltage range	184 – 264.5							Vac
AC frequency(nominal)	50/60 ±5							Hz
Maximum continuous output current	12	16.5 <sup>2</sup>	19.5 <sup>2</sup>	22	16	27	27	A
Max. continuous overcurrent protection	12	16.5 <sup>2</sup>	19.5 <sup>2</sup>	22	16	27	27	A
Residual current detector/ Residual current step detector	300/30							mA
Inrush current AC (Peak/Duration)	57.5/0.6							A/ms
Max. output fault current	38							A
Power factor range	+/- 0.9 to 1.0							
Protective class	Class I							
Utility monitoring, islanding protection, country configurable thresholds	Yes							
Overvoltage category	III							
<b>Input</b>								
Recommended Maximum DC power <sup>3</sup> (Module STC)	2400	3300	3900	4400	5500	6600	6600	W
Transformer-less, ungrounded	Yes							
Maximum input voltage	500							Vdc

<sup>1</sup> For model SE5000, it is set to 4985W in Australia, and 4600W in Germany and Czech Republic.

<sup>2</sup> 16A when the country is set to Denmark, Portugal, UK, or Poland. For other countries, contact SolarEdge.

<sup>3</sup> For detailed information regarding allowed oversizing, refer to [http://www.solaredge.com/files/pdfs/inverter\\_dc\\_oversizing\\_guide.pdf](http://www.solaredge.com/files/pdfs/inverter_dc_oversizing_guide.pdf)

	SE2200	SE3000	SE3500	SE4000	SE4000-16A	SE5000	SE6000	Unit
Nominal DC input Voltage	350							Vdc
Maximum input current	8.5	11.5	13.5	15.5	15.5	19.5	23	Adc
Maximum back-feed current	0							Adc
Reverse-polarity protection	Yes							
Ground-fault isolation detection	600 kΩ Sensitivity							
Overvoltage category	III							
Maximum inverter efficiency	97.6							%
European weighted efficiency	97.6	97.6 <sup>1</sup>	97.5	97.5	97.5	97.4	97.4	%
Night-time power consumption	<2.5							W
<b>Additional Features</b>								
Supported communication interfaces	RS485, RS232, Ethernet, ZigBee (optional)							
<b>Standards Compliance</b>								
Safety	IEC-62103 (EN50178), IEC-62109							
Grid connection standards	VDE-AR-N-4105, VDE 0126-1-1, AS-4777, RD-1663, DK 5940							
Emissions	IEC61000-6-2, IEC61000-6-3, IEC61000-3-11, IEC61000-3-12, FCC part15 class B							
RoHS	Yes							
<b>Installation Specifications</b>								
AC output	Cable Gland - diameter 9-16							mm
DC input	1 MC4 pair			2 MC4 pairs				
Dimensions (W x L x H)	540 x 315 x 172			540 x 315 x 191			mm	
Weight	20.2			21.7			kg	
Cooling	Natural Convection							
Noise	<50							dBA
Operating temperature range <sup>2</sup>	-20 - +50 (M40 version -40 to + 50)							°C
Operating humidity – non condensing	<95							%

<sup>1</sup> 97.5 for SE3000 with AC current limit of 16A

<sup>2</sup> For inverter power de-rating refer to the application note at <http://www.solaredge.com/files/pdfs/se-temperature-derating-note.pdf>

	SE2200	SE3000	SE3500	SE4000	SE4000-16A	SE5000	SE6000	Unit
Protection Rating/Environmental category	IP65 – Outdoor and Indoor							
Maximum altitude	2000							m
Pollution degree classification (inside/outside)	2/3							
Bracket mounted (bracket provided)								

## Three Phase Inverters

	SE5K	SE7K	SE8K	SE9K	SE10K	SE12.5K	SE15K	SE16K	SE17K	Unit
<b>Output</b>										
Rated AC power output	5000	7000	8000	9000	10000	12500	15000	16000	17000	VA
Maximum AC power output	5000	7000	8000	9000	10000	12500	15000	16000	17000	VA
AC output voltage – line to line / line to neutral (nominal)	380/220; 400/230									Vac
AC output voltage range	184 – 264.5									Vac
AC frequency	50/60 ± 5									Hz
Maximum continuous output current (per phase)	8	11.5	13	14.5	16	20	23	25.5	26	A
Maximum continuous overcurrent protection	8	11.5	13	14.5	16	20	23	25.5	26	A
Residual current detector / Residual Current step detector	300 / 30									mA
Grid supported – three phase	3 / N / PE ; 230 / 400									
Inrush current AC (Peak/Duration)	154/0.050									A/ms
Maximum output fault current	33						40			A
Power factor range	+/-0.9 to 1.0									
Protective class	Class I									
Utility monitoring, islanding protection, country configurable thresholds	Yes									
Overvoltage category	III									

	SE5K	SE7K	SE8K	SE9K	SE10K	SE12.5K	SE15K	SE16K	SE17K	Unit
<b>Input</b>										
Maximum DC power <sup>1</sup> (Module STC)	5500	7700	8800	9900	11000	13700	16500	17600	18700	W
Transformer-less, ungrounded	Yes									
Maximum input voltage	950									Vdc
Nominal DC input voltage	750									Vdc
Maximum input current	8.5	12	13.5	15	16.5	21	22	23	23	Adc
Maximum back-feed current	0									Adc
Reverse-polarity protection	Yes									
Ground-fault isolation detection	1M $\Omega$ Sensitivity									
Overvoltage category	III									
Maximum inverter efficiency	98									%
European weighted efficiency	97.3	97.3	97.5	97.5	97.6	97.7	97.6	97.7	97.7	%
Night-time power consumption	< 2.5									W
<b>Additional Features</b>										
Supported communication interfaces	RS485, RS232, Ethernet, ZigBee (optional)									
<b>Standards Compliance</b>										
Safety	IEC-62103 (EN50178), IEC-62109									
Grid connection standards	VDE-AR-N-4105, VDE 0126-1-1, AS-4777, RD-1663, DK 5940									
Emissions	IEC61000-6-2, IEC61000-6-3, IEC61000-3-11, IEC61000-3-12, FCC part15 class B									
WEEE, RoHS	Yes									
<b>Installation Specifications</b>										
AC output	Cable Gland - diameter 15-21									mm
DC input	2 MC4 pairs									
Maximum installation height	2000									m
Dimensions (WxLxH)	540 x 315 x 260									mm
Weight	33.2									kg

<sup>1</sup> For detailed information regarding allowed oversizing, refer to  
[http://www.solaredge.com/files/pdfs/inverter\\_dc\\_oversizing\\_guide.pdf](http://www.solaredge.com/files/pdfs/inverter_dc_oversizing_guide.pdf)

	SE5K	SE7K	SE8K	SE9K	SE10K	SE12.5K	SE15K	SE16K	SE17K	Unit
Operating temperature range <sup>1</sup>	-20 - +60 (M40 version -40 to + 60)									°C
Operating humidity – non condensing	<95									%
Cooling	Fan (user replaceable)									
Noise	< 50									dBA
Protection rating/ Environmental category	IP65 Outdoor and indoor									
Maximum altitude	2000									m
Pollution degree classification (inside/outside)	2/3									
Bracket mounted (bracket provided)										

Recommended circuit breaker/fuse size to use at the connection point of the SolarEdge inverter to the grid:

Inverter	Maximum Output Current (A)	Suggested Fuse Rating (A)
SE2200	12	16
SE3000	16.5	20
SE3500	19.5	25
SE4000	22	25
SE4000-16A	16	20
SE5000	27	32
SE6000	27	32
SE5k	8	10
SE7k	11.5	16
SE8k	13	16
SE9k	14.5	20
SE10k	16	20
SE12.5k	20	25
SE15k	23	25
SE16k	25.5	32
SE17k	26	32

<sup>1</sup> For inverter power de-rating refer to the application note at the following link: <http://www.solaredge.com/files/pdfs/se-temperature-derating-note.pdf>



## Inverter and Mounting Bracket Dimensions

The following figures provide dimensions of the inverter and mounting brackets for the single and three phase inverters. All dimensions are in mm. The mounting bracket weighs 1.3kg.

### Single Phase Inverter and Mounting Bracket

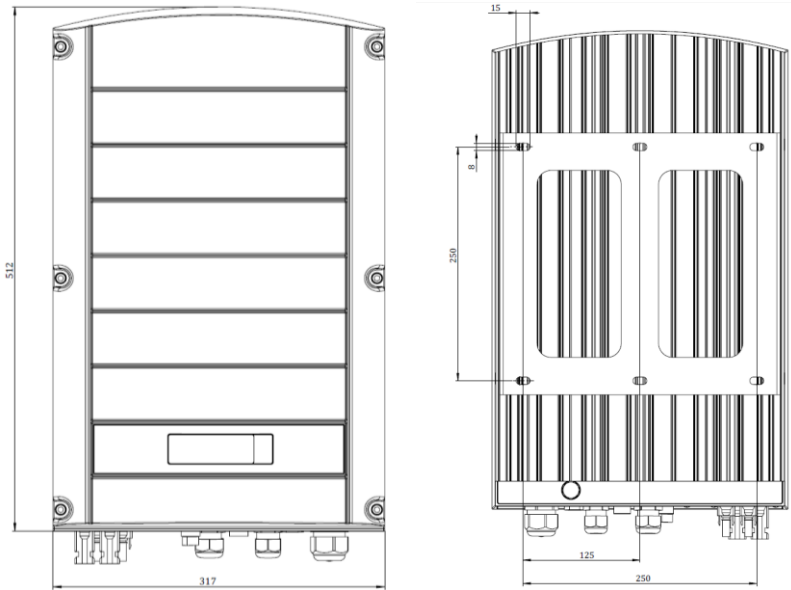

Figure 26: Single phase inverter with bracket - front and rear views

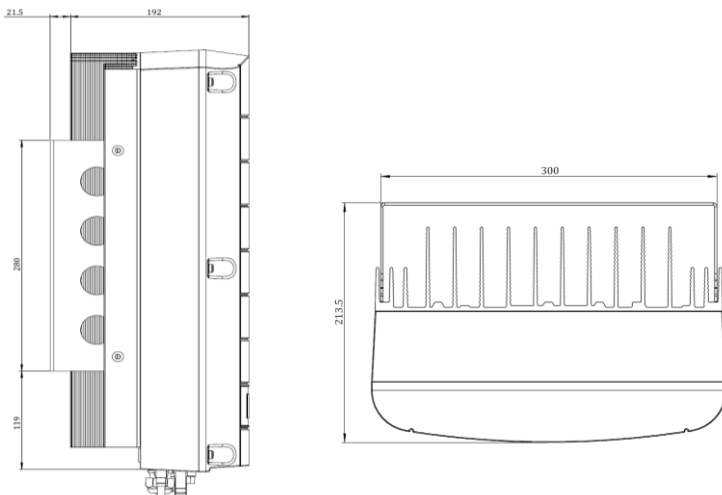

Figure 27: Single phase inverter with bracket - side and top views

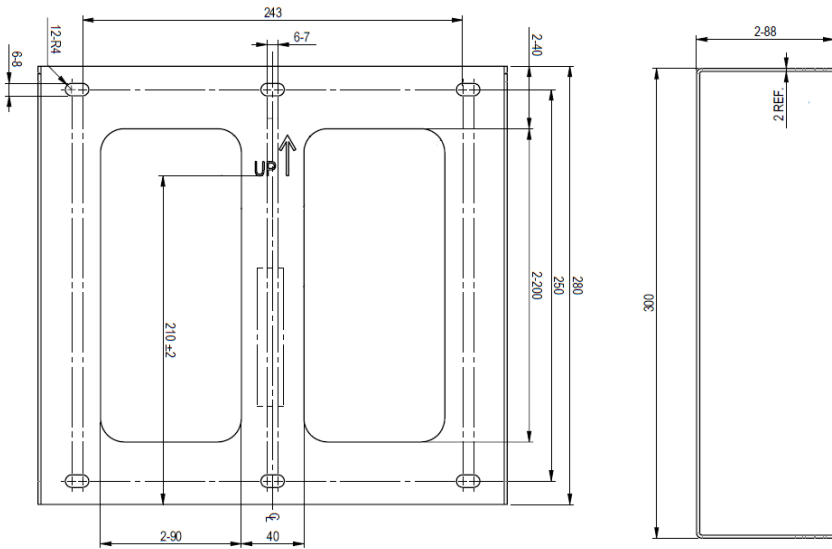

Figure 28: Single phase inverter mounting bracket

# Three Phase Inverter and Mounting Bracket

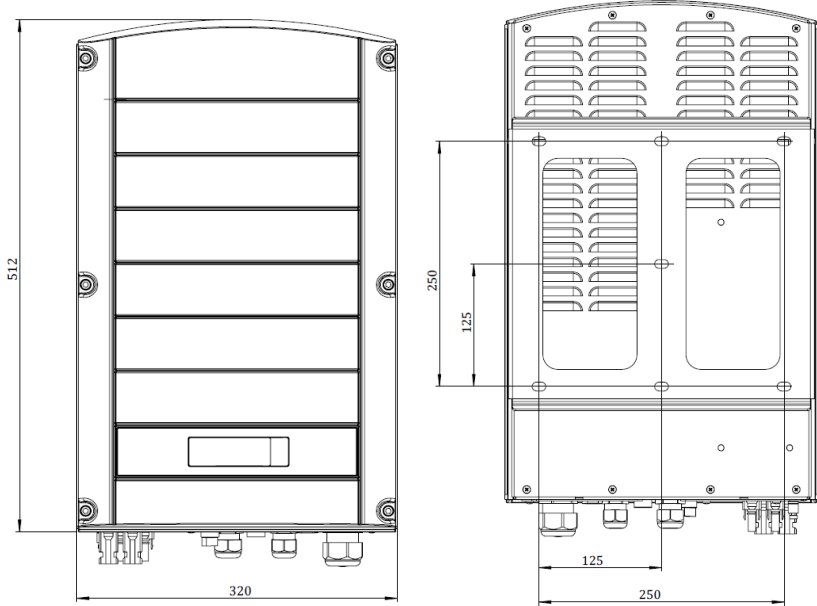

Figure 29: Three phase inverter with bracket - front and rear views

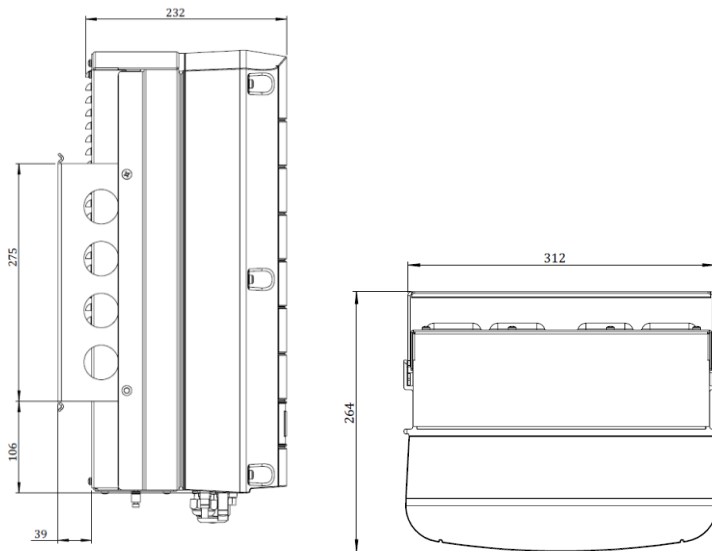

Figure 30: Three phase inverter with bracket - side and top views

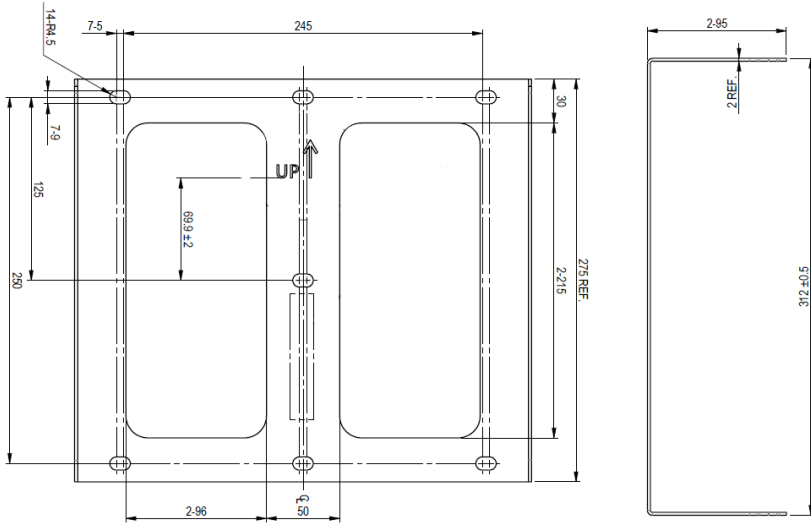

Figure 31: Three Phase Inverter Mounting Bracket

## Appendix C: Safe DC

When AC supply to the inverter is shut off (by shutting off the AC breaker at the site), or when the inverter ON/OFF switch is turned to OFF, the DC voltage drops to a safe voltage of 1V per optimizer.

The SolarEdge inverters are certified for compliance with the following standards as disconnection devices for PV generators, meaning that they can replace a DC disconnect:

- IEC 60947-3:1999 + Corrigendum: 1999 + A1:2001 + Corrigendum 1:2001 + A2:2005;
- DIN EN 60947-3
- VDE 0660-107:2006-03
- IEC 60364-7-712:2002-05
- DIN VDE 0100-712:2006-06.

In compliance with these standards, the disconnection mechanism operates as follows:

- 1** Turn the inverter ON/OFF switch, located at the bottom of the inverter, to OFF, or disconnect the AC by shutting off the AC breaker at the site. The DC voltage displayed on the inverter LCD begins to decrease.  
If the AC breaker was shut off, the LCD does not display. In this case, wait five minutes.
- 2** When the DC voltage reaches a safe voltage, the PV connectors at the input to the inverter can be disconnected. A galvanic separation then exists between the PV array and the inverter.

The disconnection is safe even under single fault conditions.

### WARNING!



Under single fault conditions, the Safe DC voltage is only guaranteed when using modules of up to:

- 95Voc when using the single phase inverter
- 70Voc when using the three phase inverter

## Appendix D: Fan Maintenance and Replacement

The three-phase inverter has two fans, one is internal and requires a SolarEdge technician to replace it (Fan 1) and the other is accessible from the outside of the inverter (Fan 2). A replacement kit is available from SolarEdge.

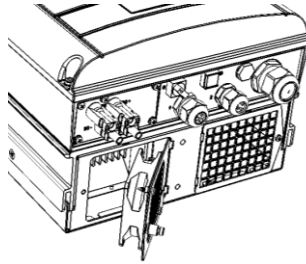

Figure 32: Inverter Fan 2

### Fan Maintenance

- 1 Keep the fan and the screen clean by blowing the dust away when it accumulates, or at least once a year.
- 2 Check the Fan Health Status screen on the LCD (refer to *Fan Health Status – Three Phase Inverters* on page 39).
- 3 If one of the following occurs, replace the fan as described in below:
  - When the fan stops operating
  - Fan status is **Replace**
  - Fan status is **Not Working**; Before replacing the fan turn the inverter AC off and on and check if the status is cleared
  - The following Error is displayed:

F a n 2 F a i l u r e

### Fan 2 Replacement

- 1 Turn OFF the inverter ON/OFF switch, and wait until the LCD indicates that the DC voltage is safe (<50V), or wait five minutes before continuing to the next step.



#### **WARNING!**

If you cannot see the inverter panel, or if a malfunction is indicated on the LCD panel, wait five minutes for the input capacitors of the inverter to discharge.

- 2 Turn OFF the AC switch of the main distribution panel.
- 3 Use a Philips screwdriver to unfasten the single screw of the fan cover.
- 4 Open the fan door.

- 5 Disconnect the fan connector and remove the fan.

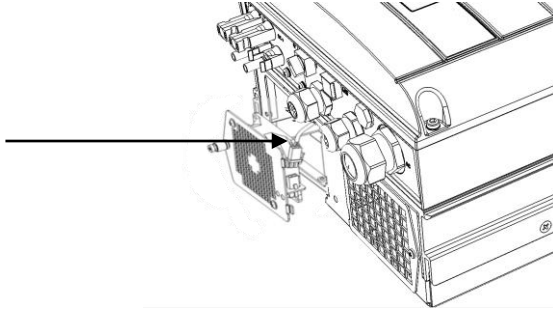

**Figure 33: Fan Connector**

- 6 Connect the fan connector to the new fan.
- 7 Close the fan door and fasten the cover screw.
- 8 Check the *Fan Health Status – Three Phase Inverters* as described on page 39.

# Appendix E: Replacing and Adding System Components

**NOTE:**

If you are permanently disassembling the installation or part of it, make sure to use the disposal methods dictated by local regulations.

## Replacing an Inverter

- 1 Turn OFF the inverter ON/OFF switch, and wait until the LCD indicates that the DC voltage is safe (<50V), or wait five minutes before continuing to the next step.

**WARNING!**

If you cannot see the inverter panel, or if a malfunction is indicated on the LCD panel, wait five minutes for the input capacitors of the inverter to discharge.

- 2 Disconnect the AC to the inverter by turning OFF the circuit breakers on the distribution panel.
- 3 Open the inverter cover.
- 4 Disconnect the DC plugs and AC wires from the inverter.
- 5 Remove the two lower screws securing the inverter to the mounting bracket and remove the inverter from the mounting bracket.

**NOTE:**

If you remove the old inverter and do not immediately install a new one, use insulation tape to isolate each of the AC and DC wires.

- 6 Place the new inverter on the mounting bracket; insert the screws securing the inverter to the mounting bracket.
- 7 Follow the instructions of *Chapter 3: Installing the Inverter* and *Chapter 4: Commissioning the Installation*.

## Adding, Removing or Replacing Power Optimizers

- 1 Turn OFF the inverter ON/OFF switch, and wait until the LCD indicates that the DC voltage is safe (<50V), or wait five minutes before continuing to the next step.

**WARNING!**

If you cannot see the inverter panel, or if a malfunction is indicated on the LCD panel, wait five minutes for the input capacitors of the inverter to discharge.

- 2 Turn OFF the AC switch of the main distribution panel.
- 3 Disconnect and connect the necessary power optimizers.
- 4 Perform pairing and other procedures described in *Chapter 4: Commissioning the Installation* on page 23 on all inverters to which power optimizers were added or from which power optimizers were removed.
- 5 In the monitoring portal, replace the serial number of the removed power optimizer with serial number of the newly installed power optimizer.



If you have technical queries concerning our products, please contact our support through SolarEdge service portal:  
<http://www.solaredge.com/groups/support/services>

North America	(Toll free) 1877 360 529 2
Australia	(Toll free) 1800 46 55 67
Germany	089 454 597 30
France	(Toll free) 0800 917 410
Italy	(Toll free) 800 784 824
Japan	(Toll free) +81.3.5530.9360
United Kingdom	(Toll free) 0800 028 1183
Belgium	(Toll free) 0800 730 41
Israel	073 240 311 8
Rest of world	+ 1 (0) 650 319 884 3
Fax	+ 972 (0) 73 240 311 7
Email to:	<a href="mailto:support@solaredge.com">support@solaredge.com</a>

[www.solaredge.com](http://www.solaredge.com)

**solar**edge  
architects of energy™



MAN-01-00057-2.2