



**PS 150**

## **SINGLE CHANNEL TELEPHONE INTERFACE**



## **USER MANUAL**

October 2013

**This product is designed and manufactured by:**

ASL Intercom B.V.  
Zonnebaan 42  
3542 EG Utrecht  
The Netherlands  
Phone: +31 (0)30 2411901  
Fax: + 31 (0)30 2667373  
E-mail: [info@asl-inter.com](mailto:info@asl-inter.com)  
Web: [www.asl-inter.com](http://www.asl-inter.com)

## CONTENT OF THIS USER MANUAL

1.0	GENERAL DESCRIPTION .....	3
2.0	INSTALLATION .....	3
3.0	FRONT PANEL CONTROLS & CONNECTOR.....	3
4.0	REAR PANEL CONNECTORS.....	4
5.0	ESTABLISHING A TELEPHONE CONNECTION.....	4
6.0	THE INTERFACES IN THE PS 150.....	5
7.0	ADJUSTING THE SIDE TONES.....	5
8.0	TECHNICAL SPECIFICATIONS PS 150 .....	6
9.0	BLOCK DIAGRAM PS 150 .....	6
10.0	PARTY LINE, TECHNICAL CONCEPT .....	7
11.0	CABLING .....	7
12.0	POSSIBLE SYSTEM CONFIGURATION.....	8
13.0	EARTHING CONCEPT.....	8

## 1.0 GENERAL DESCRIPTION

The PS 150 is designed to interface an ASL intercom system (3-wire party line) to a telephone system (2-wire). Communication can be achieved between a telephone line and one or several ASL user stations or between two ASL intercom systems via a telephone line.

The unit is a combination of two interfaces. One interface splits the intercom party line into a separate audio input and output; the other interface splits the telephone line into a separate audio input and output. The inputs and outputs are internally cross-connected.

Adjustable side tone circuits allow optimizing input/output separation for the intercom line and for the telephone line. For a good performance of the PS 150 the side tones have to be adjusted carefully. The built-in test tone generator assists to adjust or check the side tone settings.

To the PS 150 a telephone set (hereinafter called "phone") may be connected to initiate a telephone connection (dialing) or to detect an incoming telephone call (the telephone is ringing).

The PS 150 is powered (30 V DC) via the intercom party line.

## 2.0 INSTALLATION

*Connecting the PS 150 to the intercom party line:*  
Connect the intercom party line cable to the intercom line connector on the rear panel.

Use professional flexible microphone cable with 2 wires and 1 shield only.

The PS 150 is fully protected against wiring mistakes (reverse power) or short circuit in the interconnecting microphone cables.

*Connecting the PS 150 to the telephone line:*  
Connect the telephone cable to the RJ-11 connector on the rear panel.

## 3.0 FRONT PANEL CONTROLS & CONNECTOR

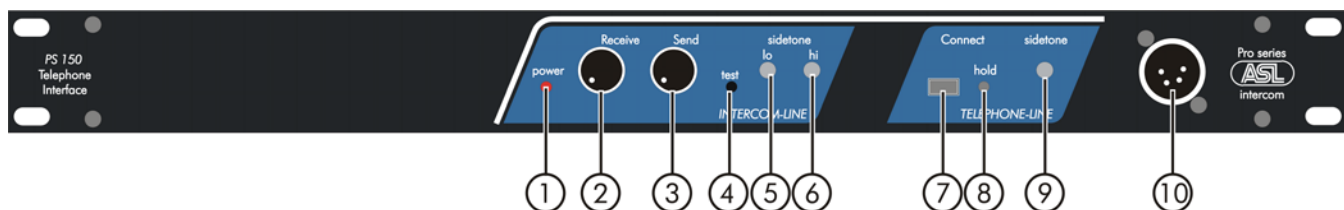

### 1 POWER indicator

This LED illuminates if 30 V DC power is supplied via the intercom line to the PS 150

### 2 RECEIVE volume knob

To control the level of the telephone signal as it is received by the intercom line

### 3 SEND volume knob

To control the level of the intercom signal as it is sent to the telephone line

### 4 TEST button

By keeping this recessed button pushed with a pin or pen a test tone generator is activated which adds a 200Hz tone to the party line. It allows adjusting or checking the side tone trimmer settings of the intercom line interface. See section 7.1

### 5 SIDE TONE LO trimmer (intercom line)

This trimmer controls the input/output separation

of the intercom line. It also compensates for the impedance of the interconnecting cable. See section 7.1

### 6 SIDE TONE HI trimmer (intercom line)

This trimmer controls the input/output separation in the high-frequency range. It also compensates for the capacity of the party line cable. See section 7.1

### 7 CONNECT button

If this (latching) button is not pushed the telephone line is switched to the telephone set (phone) which is connected to #12. If pushed, the telephone line is connected to the PS 150. See section 5.0

### 8 HOLD indicator LED

This LED illuminates if the telephone line is switched to the PS 150, which is then 'on-line'. See section 5.0

## 9 SIDE TONE trimmer (telephone line)

This trimmer controls the input/output separation of the telephone line. See section 7.2

## 10 TEST HEADSET connector

To this XLR-4 connector a headset or headphones can be connected, allowing to listen to the intercom line during the adjustment of the side tone of the intercom line interface. See section 7.1

Pin assignment :

Pin 1: not connected

Pin 2: not connected

Pin 3: phones +

Pin 4: phones (GND)

## 4.0 REAR PANEL CONNECTORS

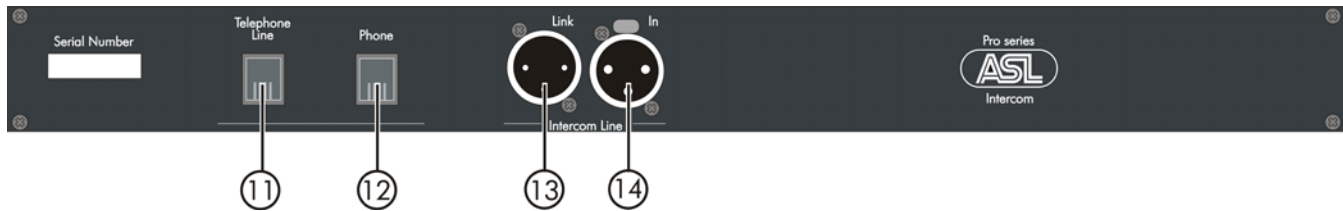

### 11 TELEPHONE LINE connector

This RJ-11 connector is for (transformer balanced) connecting the telephone line

RJ-11 wiring :

Pin 1: not existing in RJ-11

Pin 2: black wire

Pin 3: red wire

Pin 4: green wire

Pin 5: yellow wire

Pin 6: not existing in RJ-11

Pin 3 & 4 = pair 1

Pin 2 & 5 = pair 2

### 12 PHONE connector

This connector is for connecting a telephone set (phone). For pin assignments see #11.

### 13 INTERCOM LINK connector

### 14 INTERCOM IN connector

XLR-3 connectors # 13 and #14 are for connecting the intercom party line (daisy chaining).

Pin assignment :

Pin 1: 0V / ground shield

Pin 2: + 30V power wire

Pin 3: audio wire

## 5.0 ESTABLISHING A TELEPHONE CONNECTION

Proceed as follows:

1. Connect the telephone cable to the TELEPHONE LINE connector (#11)
2. Connect a telephone set (phone) to the PHONE connector (#12)
3. Make sure that the CONNECT button is not pushed. The telephone line is switched to the telephone set (phone). The HOLD Led is not lit, indicating that the PS 150 is "off-line"
4. Take the telephone handset from the hook (one hears a dial tone) and dial a phone number
5. After a telephone connection has been made, push the CONNECT button. The telephone line is now switched to the PS 150 and no longer to the phone. The HOLD Led is lit, indicating that the PS 150 is "on-line"
6. Place the telephone handset back on the hook of the telephone set (phone)

To terminate a telephone connection, push the CONNECT button again. The HOLD Led now extinguishes and the PS 150 is "off-line".

## 6.0 THE INTERFACES IN THE PS 150

The PS 150 contains two interfaces. One interface splits the signal on the intercom party line into a separate audio input and output. The other interface splits the signal on the telephone line into a separate audio input and output. The inputs and outputs are internally cross connected.

Each interface has its own side tone trimming. The trimmers in the 'intercom line' section of the front panel control the input/output separation of the intercom line interface. The trimmer in the 'telephone section' of the front panel controls the input/output separation of the telephone line interface.

To prevent internal feedback or a 'hollow sound' in the intercom and the telephone system, all side tone trimmers must be adjusted carefully.

Due to the complex impedance of the telephone line, its input/output separation may be not as good as the one of the intercom line. This may also decrease the side tone rejection in the intercom stations on the intercom party line connected to the PS 150.

If speaker stations are connected feedback may occur. To prevent this keep the SEND and RECEIVE levels of the PS 150 low and turn the speaker attenuator trimmers of the howling speaker stations counter-clockwise.

## 7.0 ADJUSTING THE SIDE TONES

7.1 To adjust the side tone of the intercom party line interface, proceed as follows:

1. plug a headset or headphones into the TEST HEADSET connector (#10)
2. set RECEIVE level to minimum
3. set SEND level to maximum
4. set intercom line side tone trimmers in start position (LO trimmer: turn fully clockwise, HI trimmer: turn fully counter-clockwise)
5. activate test tone generator by pushing recessed button #4 with a pen or pin
6. decrease test tone listen level in the test headset/headphone to a minimum by turning the LO trimmer counter-clockwise.
7. decrease the listen level of the remaining high frequencies to a minimum by turning the HI trimmer clockwise.
8. repeat step 6 and 7 until you have obtained the best possible settings (minimal levels).

Since the test tone is placed onto the intercom line all connected intercom stations hear this tone. This may be rather disturbing. It is advised to not adjust this side tone whilst the intercom system is use.

7.2 To adjust the side tone of the telephone line interface, proceed as follows:

1. Make sure that procedure 7.1 has been executed
2. connect an ASL user station to the intercom party line, connect a headset to that user station and adjust the side tone of that station to minimum level
3. Connect the PS 150 to the telephone line
4. Push the CONNECT button (#7). The PS 150 is now on-line. In the headset can(s) you temporarily hear a dial tone
5. Set the side tone trimmer of the telephone line interface (#9) in start position: fully clockwise
6. set RECEIVE level to minimum
7. turn up RECEIVE level slowly while speaking into the headset microphone. The volume of your voice in the headset can(s) will increase.
8. Turn telephone line side tone trimmer counter-clockwise and adjust for minimum level of your voice in the headset can(s)
9. Repeat step 7 and 8 a few times until you have obtained the best possible setting (minimal level).

## 8.0 TECHNICAL SPECIFICATIONS PS 150

### Intercom Line Driver

Max. output current: 3 mA rms  
output impedance: > 150 kΩ

### Intercom Line Side Tone

Rejection: > 30 dB

### Telephone Line Driver

output impedance : 600 Ω  
max. output: +14 dBu  
frequency response: 150 Hz - 6 kHz (-3 dB)

### Telephone Line Side Tone:

Rejection: > 10 dB (300 Hz - 3 kHz)

### Dimensions & Weight PS 150

Width: 483 mm  
Height: 44 mm  
Depth: 124 mm  
Weight: 2800 grams

0 dBu is defined as 775 mV into open circuit

ASL reserves the right to alter specifications without prior notice.

## 9.0 BLOCK DIAGRAM PS 150

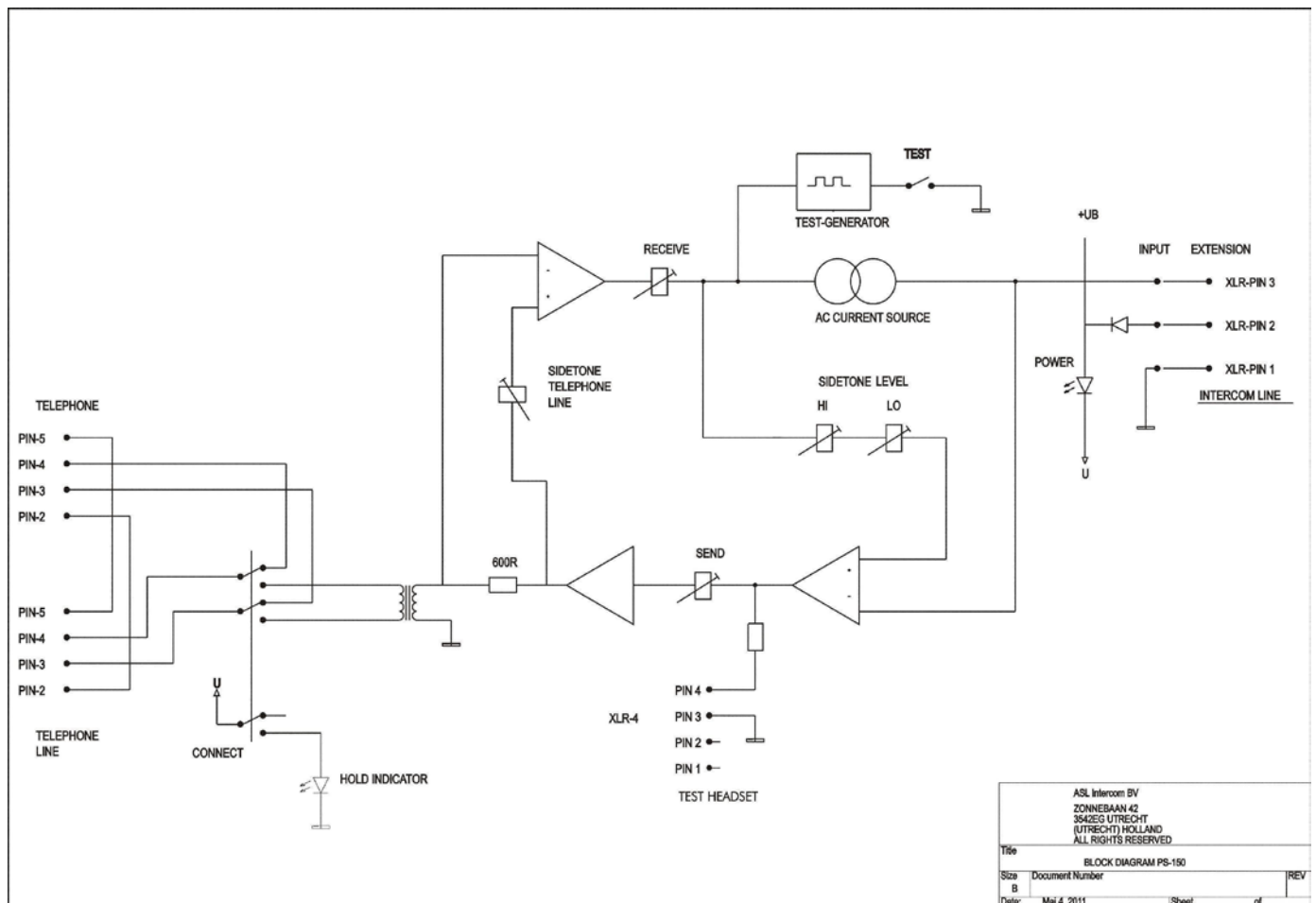

## 10.0 PARTY LINE, TECHNICAL CONCEPT

User stations in an ASL intercom system are connected via one or several 'party lines'. A party line offers two way ('full duplex') communication and consists of standard microphone (multi-pair) cable. One wire is used as an audio line, one as a power line and the screen of the cable functions as earth/return. Current drive is used for signal transfer. Each station utilizes a current amplifier to amplify the microphone signal and place it on the common audio line where, due to the constant line impedance (situated in the power supply between XLR pin 3 and 1), a signal voltage is developed which can be further amplified and sent to the headphones or loudspeakers.

This principle has three advantages:

- the use of a single audio line allows several stations to talk and listen simultaneously
- due to the high bridging impedance offered by each station, the number of stations on the party line has no influence on the level of the communications signal
- power and audio to the intercom stations use the same cable

The Call signal is also sent as a current on the audio line. It develops a DC potential over the line impedance which will be sensed by each station and interpreted as a Call signal.

## 11.0 CABLING

The intercom lines (the 'party lines') are of the shielded two-conductor microphone cable type. The intercom line connectors are of the XLR-3 type. Audio and Call signals are on pin 3, DC power is on pin 2 and pin 1 is connected to the shield of the cable which functions as the common return for audio and power.

The audio signal is transferred in an unbalanced way (see 'Party Line, Technical Concept').

To avoid earth loops (hum), the possible effect of electromagnetic fields and to minimize power loss, certain rules have to be obeyed when installing the cabling of an intercom system :

### **Use high quality cable**

Use high quality microphone cable (shielded two conductor cable, minimum 2x 0.30 mm<sup>2</sup>). In case multi-pair microphone cable is used, it should consist of two conductors (minimum 2x 0.15 mm<sup>2</sup>) with separate shield and an overall shield.

### **Use flexible cable**

Use flexible single and multi-pair microphone cable instead of cable with solid cores, especially when the cable is subjected to bending during operation or installation.

### **Cable screens to XLR pin 1**

The screen of each separate microphone cable and/or the screen of each single pair in a multi-pair cable should be connected to pin 1 of each XLR-3 connector. Do not connect these screens to the metal housing of ASL units or XLR-3 wall boxes. See section 'Earthing Concept'.

### **Connect metal cable trunks, wall boxes and overall multi-pair cable screens to clean earth**

Metal cable trunks, metal wall boxes and overall multi-pair cable screens should be interconnected and, at the 'central earth point' in the intercom network, be connected to a clean earth or a safety earth. See section 'Earthing Concept'.

### **Keep metal connection boxes and cable trunks or pipes isolated from other metal parts**

Metal trunks or pipes for intercom cables and metal connection boxes should be mounted in such a way that they are isolated from any other metal housing or construction part.

### **Keep cables parallel as much as possible**

When two (multi channel) units in a network are connected by more than one cable, make sure that these cables are parallel to each other over the whole distance between those units. When using multi-pair cable, parallelism is ensured in the best possible way.

### **Avoid closed loops**

Always avoid that intercom cables are making a closed loop. So-called 'ring intercom' should not physically be cabled as a ring..

### **Keep cables away from electromagnetic sources**

Keep intercom cables away from high energy cables, e.g. 115/230/400V mains power or dimmer controlled feeds for spotlights. Intercom cables should cross high energy cables at an angle of 90° only. Intercom cables should never be in the same trunks as energy cables.

### **Place power supply in a central position**

In case of a system powered by a separate power supply: In order to diminish power losses, place the power supply as close as possible to where most power consumption occurs, in other words most user stations are placed.

### **ASL powered units to a 'clean' mains outlet**

Master stations or power supplies should be connected to a mains outlet with a clean earth. Other audio equipment may be connected to this mains outlet, but avoid using an outlet which also powers dimmer controlled lighting systems.

## 12.0 POSSIBLE SYSTEM CONFIGURATION

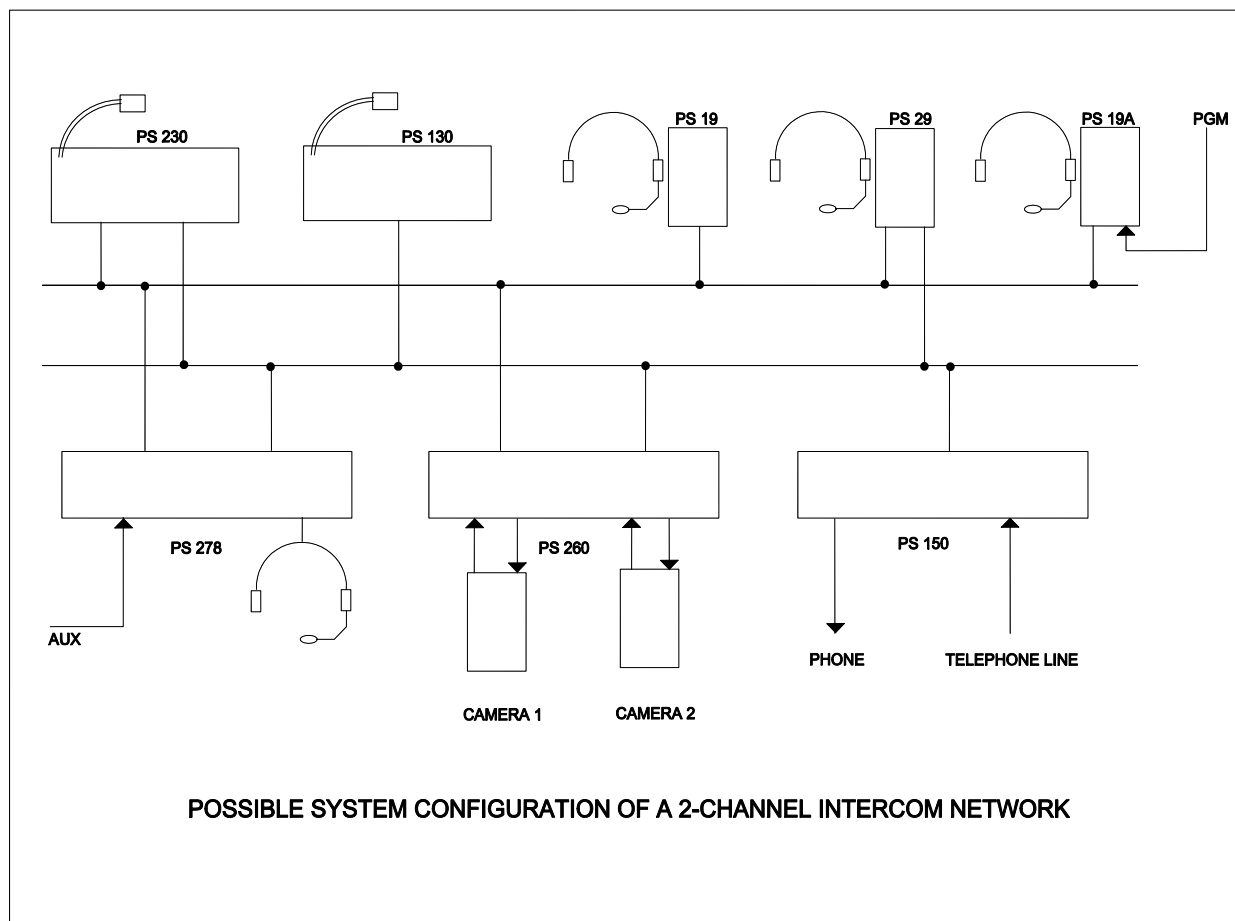

## 13.0 EARTHING CONCEPT

