

The TRC Multi Controller USER MANUAL for connecting Switches / Servos / LEDs

Version 1.7 – 7 April 2009

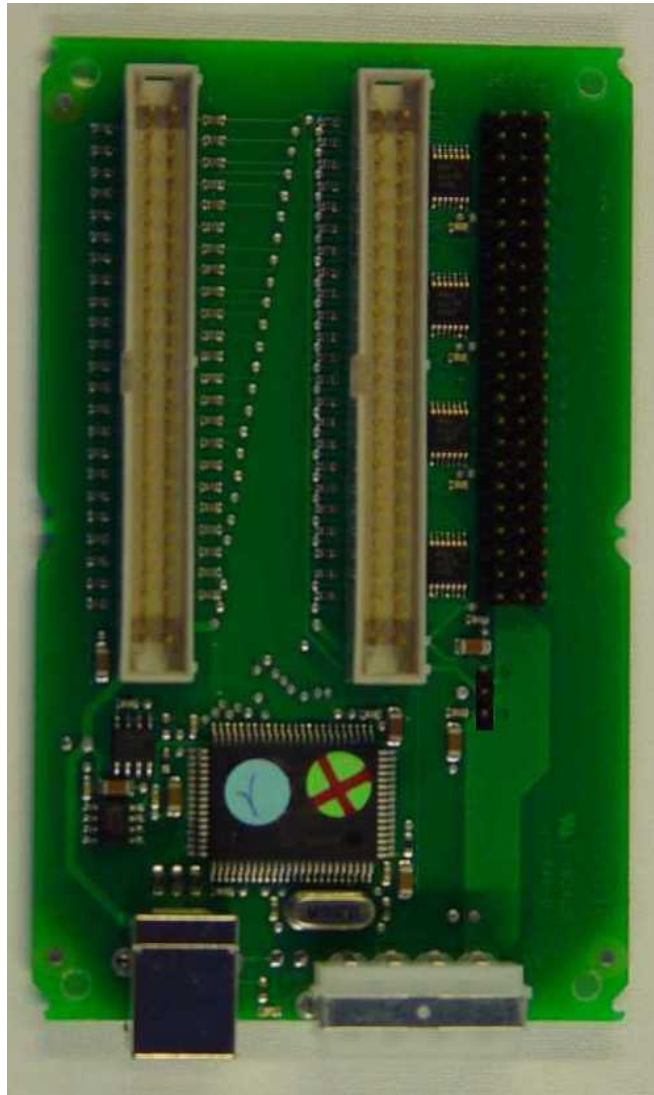

The perfect controller board for building your cockpit

*Connect up to 736 hardware devices to Microsoft Flight Simulator
using Multi Controllers and choose out of 1100 different instruments/indicators
or other type of Input/Output devices !*

Includes Project Magenta Codes

Update from version 1.3 manual and software:

- New calibration system (calibration points are given by user in floating point)
- "Apply" button renamed to "Save calibration"
- User will prompted when closing the application to confirm whether or not the calibration must be saved.
- Fixed Stall Warning
- Fixed Overspeed Warning
- Added Engine 1 / 4 ITT in celcius and fahrenheit (see description below)
- Added Cabin Temperature / Climb / Alt (see description below)

TRC Code	Type	Description	FSUIPC Code
443	S	Turbine Engine 1 ITT (interstage turbine temperature) in degrees Celcius	2038
444	S	Turbine Engine 1 ITT (interstage turbine temperature) in degrees Fahrenheit	2038
445	S	Turbine Engine 2 ITT (interstage turbine temperature) in degrees Celcius	2138
446	S	Turbine Engine 2 ITT (interstage turbine temperature) in degrees Fahrenheit	2138
447	S	Turbine Engine 3 ITT (interstage turbine temperature) in degrees Celcius	2238
448	S	Turbine Engine 3 ITT (interstage turbine temperature) in degrees Fahrenheit	2238
449	S	Turbine Engine 4 ITT (interstage turbine temperature) in degrees Celcius	2338
450	S	Turbine Engine 4 ITT (interstage turbine temperature) in degrees Fahrenheit	2338
904	S	Cabin Temperature (factor 0.1)	567E
905	S	Cabin Climb (factor 10)	56A4
906	S	Cabin Alt (factor 10)	56A6

Update from version 1.4 manual and software:

TRC Code	Type	Description	FSUIPC Code
907	S	APU-EGT	5604
908	S	BleedPSI1 (Duct Press 1)	567A
909	S	BleedPSI2 (Duct Press 2)	567C
910	S	CabinDiffPress	56B8

Contents

1. TRC programmable Multi Controller.....	5
2. The control software	8
C. The Multi Controller driver software mclink.exe.....	9
3. Installing the software.....	10
4. Connecting the Multi Controller to your PC for the first time	13
5. Using the Multi Controller “Number Assign” program: mcnum.exe.....	15
Step 4 – IMPORTANT!.....	16
6. About the I/O line assign and calibration software (mccal.exe)	17
PM codes *	17
7. Using the I/O assign and calibration software mccal.exe.....	18
WARNING !!!	20
8. Calibration of connected Gauges (servos).....	21
__Example 1: Calibrating a Vertical Speed Indicator.....	22
__Example 2: Calibrating a 450 knots Airspeed Indicator	23
__Example 3: calibrating a Flaps Indicator	24
9. Using the MC Link program.....	25
10. Table of I/O possibilities based on FSUIPC codes	26
11. Table of I/O possibilities based on Project Magenta codes – table 1	36
12. Table of I/O possibilities based on Project Magenta codes / Table 2	43
13. How to connect instruments to the I/O lines of the Multi Controller	53
14. Hardware pin assignment of the Multi Controller	54
15. How to connect Switches, LED’s and Gauges (Servos) correctly	54
16. Schematics	55
17. Multi Controller Connector Table.....	57
18. Available expansion boards for the Multi Controller	58
The “Screw Terminal” expansion board.....	Fout! Bladwijzer niet gedefinieerd.
19. Additional important information.....	59

Important: Please read the remark on assigning a sequence number to the Multi Controller in

Chapter 3 and 5 prior to connecting any Multi Controller to your USB port!!!

*This manual and the software to control the Multi Controller are copyrighted by TRC Development b.v.
Nothing from this manual may be used, published or otherwise copied without prior written approval from
TRC Development b.v. – The Netherlands.*

Original Publish date: August 1, 2005

1. TRC programmable Multi Controller

No programming knowledge necessary!

The TRC programmable “Plug-and-Play” Multi Controller is a USB connected I/O board offering 23 Input/Output lines. Each I/O line is capable of a.) driving an LED (Light Emitting Diode, max. 20 mA), b.) driving a servo motor, or c.) reading the position of a switch.

You choose the function of each I/O line. Each line contains three connectors (input connector, output connector and servo connector). These lines may be used to control many different flight simulator functions.

The Multi Controller can control single or dual pointer gauges. It cannot control gauges which need to feed back positioning signals to the controller, like the Altimeter, Heading Indicator, VOR1/2, ADF or Wet Compass. Therefore you need to use a CCU or SIC board.

When using already a CCU or SIC, you can use Multi Controller(s) to expand your cockpit to even a 6 engine aircraft with many, many additional gauges, switches or LED signals.

The Multi Controller software (included with the controller board) uses the I/O system from the FSUIPC software (written by Pete Dowson) to connect to Microsoft Flight Simulator. This PC compatible software is capable of recognizing up to 32 Multi Controllers connected to the PC via a single USB cable, thereby creating the most advanced control system for flight simulation ever (multiple USB devices can be connected by daisy chaining USB hubs).

The version 1.3 release of the Multi Controller software does support Project Magenta (see www.projectmagenta.com) codes (see tables).

Note: A separate license is required in order to use FSUIPC software to connect MS Flight Simulator to Project Magenta. Contact www.schiratti.com/dowson.html to obtain the necessary license.

No programming knowledge is required. To assign an instrument or a function to an Input/Output line, merely select the instrument or function from a list of over 250 possibilities!

You may assign one I/O line drive an LED, another to drive a servo motor on a SimKits instrument, and a third to read the position of a switch. You have unlimited possibilities with the new TRC programmable Multi Controller.

By adding one or more inexpensive USB hubs to your PC, you may connect up to 32 of these controllers to your PC. This will allow the connection of up to 736 instruments, 736 switches, 736 LED's

(outputs) to your PC (or a combination thereof), thus allowing nearly limitless possibilities in simulator configuration!

The TRC programmable Multi Controller uses the same proven technical architecture as the Central Control Unit (CCU), and may be the ultimate solution for designing your cockpit!

To drive servos or multiple LED's, you will need to connect a standard PC power supply to the power connector on the board. Should you use the board to "read" inputs only (like switches), the power supplied via the USB cable is sufficient, since this drives the electronics on the board only. You can connect a maximum of 23 different instruments to each Multi Controller (one per I/O line).

Note: If using multiple "daisy chained" hubs, it is highly recommended to use powered hubs, since the output of a PC can normally deliver a maximum of 500mA.

For example, should you use a single Multi Controller and assign all the outputs to drive LED's (20mA each), power consumption from the USB is approximately 480mA when a separate power supply is not used. This is approximately the maximum output available from a USB connection.

However, if you connect an external PC power supply to the Multi Controller and configure the jumpers so that this external power is used to drive the LED's etc., you will not need powered hubs when connecting only a few (up to 10) Multi Controllers.

OUTPUT

Each I/O line can be configured as an Output. You can connect an LED to this line via a current limiting resistor, or you may connect a small relay to drive heavier electric loads. The maximum current output per I/O line is 20mA. An LED in combination with a current limiting resistor uses less than 20mA.

Note: The current limiting resistor is already mounted on the Multi Controller.

Then by using the included software, you assign this output of the Multi Controller to a certain function in Microsoft Flight Simulator (ie. panel lights).

INPUT

Each I/O line can also be configured as an Input. You can then connect one side of a switch to this I/O line and connect the other side of the switch to ground (available on the I/O connector). Then by again using the included software, you assign this switch to a function in Microsoft Flight Simulator (ie. avionics on/off).

SERVO

Each I/O line can also be configured to drive a servo to control a pointer on an instrument, such as the needle on the manifold pressure gage. You will need to connect a standard PC power supply to the Multi Controller board and place a jumper into the correct position (see block schematics) in order to feed this external power to the servo.

The software used to control the setting of the TRC programmable Multi Controller has an easy “click and assign” interface. This enables you – without programming knowledge – to assign the function of each I/O line to an instrument or other function within Microsoft Flight Simulator via the FSUIPC interface software.

2. The control software

To use the Multi Controller board and to assign a certain I/O line to a function in Microsoft Flight Simulator, no programming knowledge is necessary. All configurations are “Click-and-Assign”.

The Multi Controller software uses FSUIPC to connect to Microsoft Flight Simulator. This program can be downloaded from the website <http://www.schiratti.com/dowson.html>. The FSUIPC installation documentation and users manual may be downloaded from this site, also.

The Multi Controller needs three (3) different software programs to function:

- A. The Multi Controller “number assign” program: **mcnum.exe**
- B. The I/O assign and calibration software: **mccal.exe**
- C. The Multi Controller Driver software: **mclink.exe**

A. The Multi Controller “number assign” program **mcnum.exe**

The first activity is to assign an identity to each Multi Controller card. This number is “programmed” once into an on-board EEPROM (electrically erasable programmable ROM), and will remain there unless you use the software again to re-program the number. Therefore, this software is normally only used once to initially identify each Multi Controller.

Note: Each Multi Controller comes from the factory assigned as a “number 1 device”, and multiple controllers must be renumbered.

Very Important: When connecting a Multi Controller to your PC to be renumbered, this must be the only controller connected at this time. Otherwise the mcnum.exe program isn't able to distinguish which controller you wish to re-number! So therefore disconnect any Simkits USB devices like the CCU, SIC, Radio Stack Controller or other Multi Controllers before you start the mcnum.exe program!!

Once this unique number/identification is assigned to the Multi Controller, the driver software will recognize it. If using only one Multi Controller, you don't have to assign a number to the board, although you may wish to do so to become familiar with the **mcnum.exe** software.

The Multi Controller may be connected either directly to a USB port on your computer or through a USB hub, which may be purchased from the SimKits website or from a local computer shop.

As each Multi Controller requires only 50mA to function, many boards may be connected to a single USB port by using non-powered hubs. However, if powering a multitude of LED's and servos, it is recommended to use a PC power supply so as to not overload the USB source.

B. The I/O assign and calibration software mccal.exe

With the Multi Controller board(s) connected to your PC and the "assign and calibration" software installed, you may begin assigning each I/O line to a certain function in Microsoft Flight Simulator or to Project Magenta. Complete instructions on how to assign and calibrate the instruments connected to a Multi Controller are found in Chapter 5.

C. The Multi Controller driver software mclink.exe

This software connects to Microsoft Flight Simulator via the FSUIPC software from Pete Dowson (see www.schiratti.com/dowson.html for more information). You will need FSUIPC version 3.xx or later.

The mclink.exe software uses the data produced by the mccal.exe software to control each I/O line and the function assigned to it.

Note: When the mclink.exe program is running, the mcnun.exe and mccal.exe programs should be closed.

3. Installing the software

Note: Do not connect the Multi Controller(s) to your PC yet.

In order to download the required files, you must first create a directory in which to store the files (such as a directory named "Multicontroller"). Then download the file "Multicontroller.zip" from the Simkits website support@simkits.com and unzip the file into this directory. Verify that you are downloading the latest version of the software, and periodically go to the website and download any updates that may be available.

The zip file contains the following files:

- Setup.exe
- trcmc.inf
- trcdrv.sys

Close all open programs and start the program Setup.exe.



Now follow the on-screen directions to install the software program.

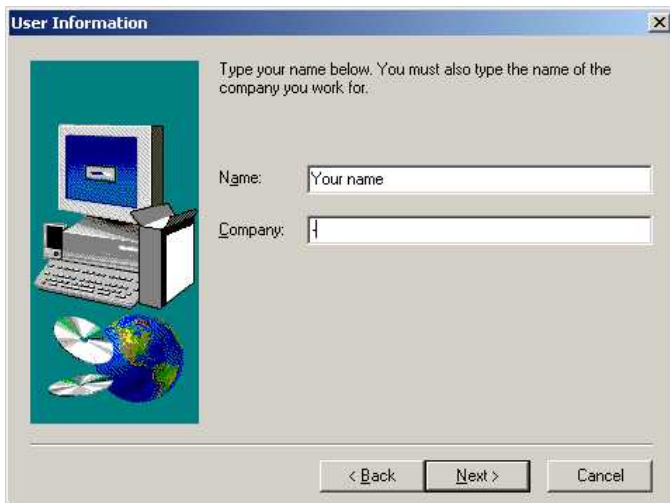

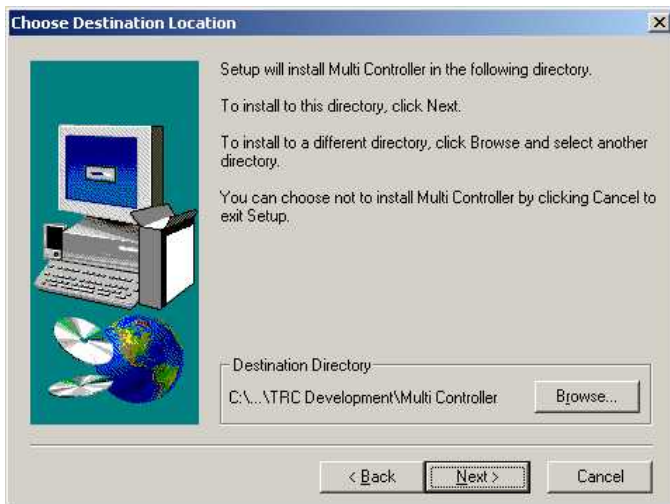

If you agree with the directory chosen by the software installation program, just click "Next".

Otherwise, browse for a new directory of your choice.



(The list of "Existing Folders" on the left is only an example, and is different from the list that will be seen on your computer!)

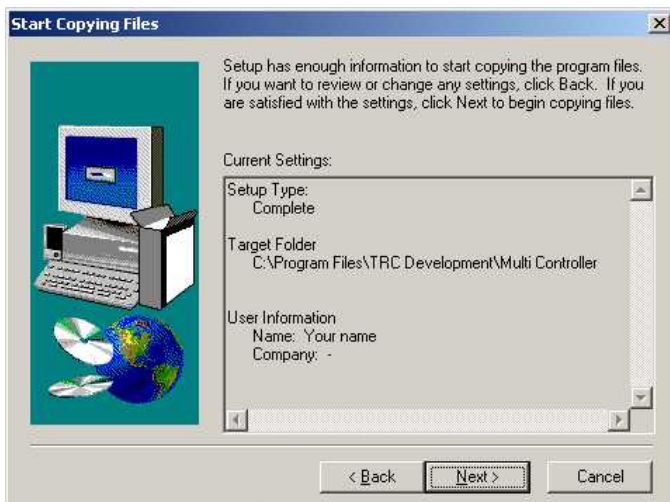

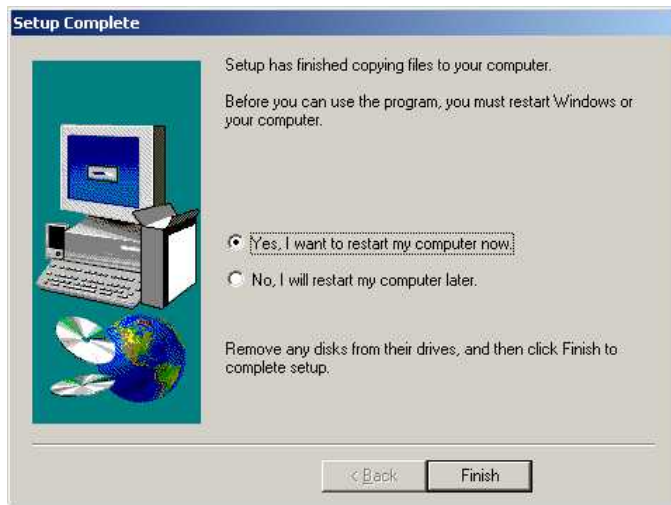

When the installation is done, click “Finish” to restart your computer. This will save the new settings.

4. Connecting the Multi Controller to your PC for the first time

Once you have installed the Multi Controller software, you may now connect the Multi Controller



board(s) to your PC using the included USB cable. Your PC will recognize the Multi Controller as a new device and the following screens will be shown:

Select “No, not this time” and click “Next”.



Now click on the option “Install from a specific location (Advanced)” and click “Next”.

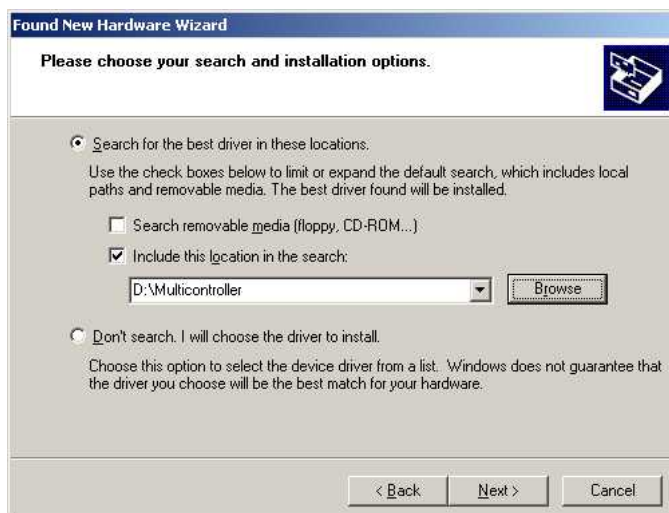

Use the “Browse” option and choose the directory into which you unzipped the downloaded software.

This directory should contain the files “trcdrv.sys” and “trcmc.inf”.

Now click “Next”.

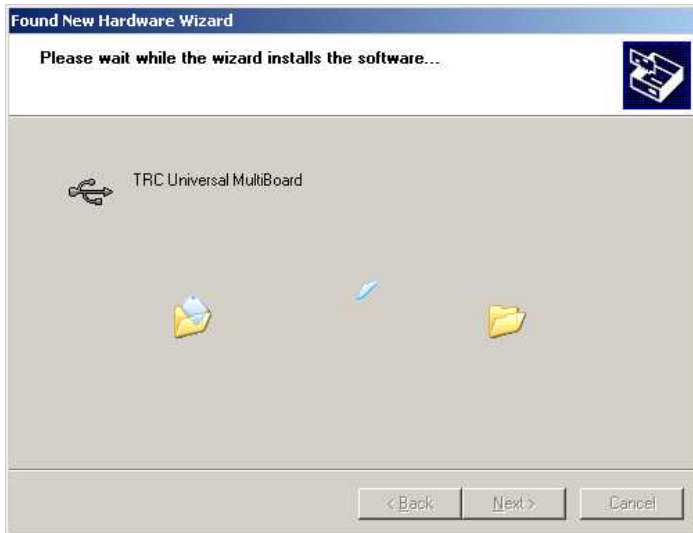

The "Found New Hardware Wizard" will start installing the driver software. This process may take several minutes.

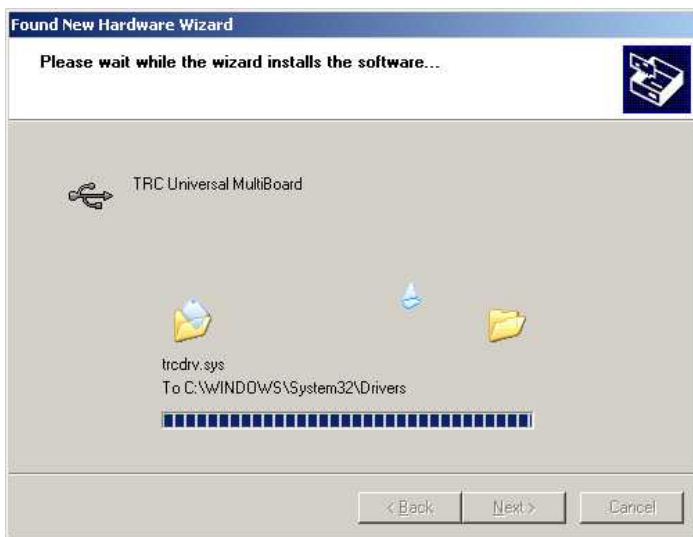

While the software is installing the driver, you will see the progress of the installation in the window on the screen.



Once the driver is installed, press the "Finish" button to finalize the installation.

Your PC may ask for a restart. If it does, restart your PC.

Then follow the directions in the next Chapter.

5. Using the Multi Controller “Number Assign” program: mcnum.exe.

The Multi Controller is delivered from the factory with the internal number set to 1. This means that should you have more than one Multi Controller connected to your PC, they would all look the same to your PC, and the software would not be able to recognize them from each other.

Therefore, TRC has developed the “Number Assign” program, called **mcnum.exe**. This program allows you to assign a number (from 1 to 32) to each Multi Controller.

Very Important: When connecting a Multi Controller to your PC to be renumbered, this must be the only controller connected at this time. Otherwise the mcnum.exe program isn't able to distinguish which controller you wish to re-number! So therefore disconnect any Simkits USB devices like the CCU, SIC, Radio Stack Controller or other Multi Controllers before you start the mcnum.exe program!!

Step 1

Disconnect all Multi Controllers from your PC except the one you are renumbering.

Step 2

Start the Multi Controller number assign program mcnum.exe. The following screen is shown:

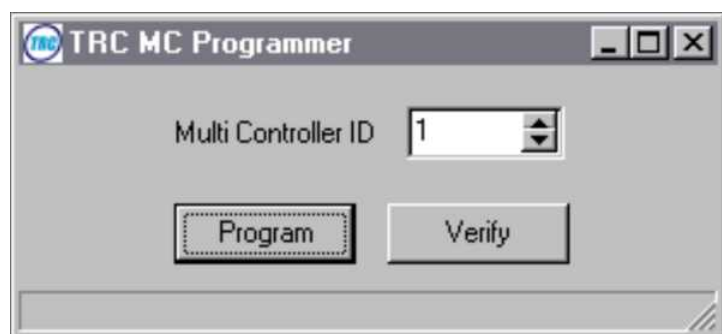

Step 3

Arrow down to the number you would like to assign to this specific Multi Controller board and press “Program”. You will automatically be asked to “verify” your selection, which will result in a message being displayed in the lower part of the window informing you about the results of the program action.

To verify that the number has been correctly assigned to the Multi Controller, connect the controller to your PC (note: only 1 at a time) and press “Verify”. This will result in a message in the lower part of the screen informing you which number has been programmed into this particular controller



Note: the field Multi Controller ID does not necessarily tell you the correct number of the Multi Controller when using the “verify” function, only the status line does!

Step 4 – IMPORTANT!

You must now temporarily disconnect the USB cable from the Multi Controller. Otherwise, your PC will not recognize the newly assigned number, and will be looking for the old number that was assigned to the controller prior to programming the new identity. Just unplug the USB cable, wait 5 seconds and plug it in again. Your PC will now recognize the controller as a new device.

Once the PC has recognized the new device, you can use it with the I/O assign and calibration software: **mccal.exe**.

6. About the I/O line assign and calibration software (mccal.exe)

This software program finally connects the Multi Controller to Microsoft Flight Simulator. As mentioned previously, you will also need the latest version of the FSUIPC software to control the standard list of instruments that are currently available to Microsoft Flight Simulator and/or Project Magenta, as well as to control additional instruments as they become available. For more information on the FSUIPC software, please consult www.schiratti.com/dowson.html.

The following list of codes depicts the general numbering system assigned to the I/O lines. The first groups of codes are FSUIPC (Flight Simulator) codes, while the second group is for Project Magenta.

Please note: The numbers used by the Multi Controller software are not necessarily identical to the FSUIPC or Project Magenta codes. Each function has been assigned a unique number for ease of assigning functions.

FSUIPC codes

The numbers 100 through 199 are reserved for Inputs

The numbers 200 through 299 are reserved for Outputs

The numbers 300 through 399 are reserved for Servos (gauges)

PM codes *

The numbers 600 through 799 are reserved for Inputs

The numbers 800 through 899 are reserved for Outputs

The numbers 900 through 999 are reserved for Servos (gauges)

7. Using the I/O assign and calibration software mcal.exe

Even though you may have previously connected a Multi Controller to your PC, after using the Number Assign program (mcnum.exe), the identification of the Multi Controller has been changed and is therefore viewed as a new item to your PC. You may need to repeat the steps in Chapter 4 to correct any errors in assignments.

When you use a new Multi Controller for the first time with the I/O assign and calibration software, there are no functions assigned to any of the I/O lines. With a previously used controller, the chart will show all assigned functions in their specific fields.

If you are not satisfied with the assignment of an I/O line or the response of a gauge, you may wish to run the mcal.exe software program again. Only the latest changes produced by running mcal.exe are saved into the parameter files.

See the following pages for directions on using the mcal.exe program.

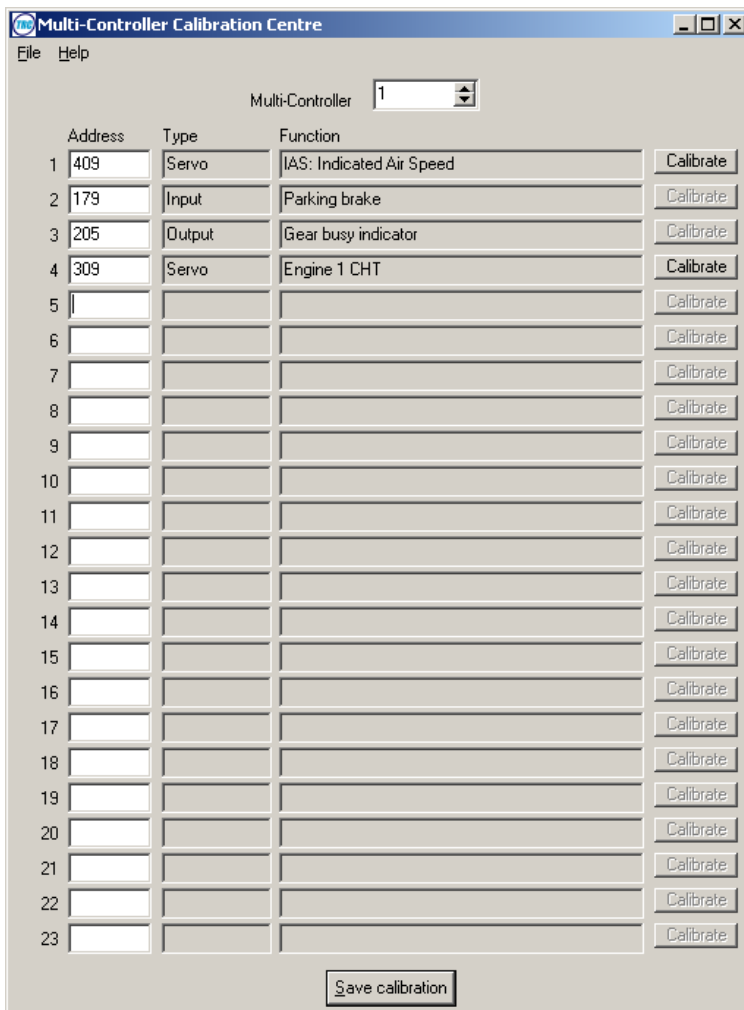

Multi Controller Calibration Centre

The Multi Controller field identifies the Multi Controller you are working on. If the dropdown list doesn't show the number of a particular controller, then the mcca.exe software has not recognized that controller.

Address

Enter the number of the desired function from the list of possible I/O functions (in the column TRC#)

The mcca.exe program recognizes the type of function you have chosen and enters it for you.

Type

Here the mcca.exe program displays the type of function you have chosen: **Servo** to drive a gauge, **Input** to read from a switch and **Output** to drive an LED or other device.

Function

Short description of the function that is assigned to this I/O line.

Calibrate

Press this button (when available) to calibrate the gauge.

Save Calibration

Press this button to save the settings.

Up to 23 I/O lines per Multi Controller

The fields are numbered from 1 to 23. By entering the appropriate number from the list from Chapter 10 or 11, you have assigned a certain function to that I/O line of the Multi Controller.

When the function is an **Output**, you don't have to do anything anymore to complete this function. The output will respond to the high or low signal from Microsoft Flight Simulator or from Project Magenta. An LED can be directly connected to the I/O line, which may draw a maximum of 20mA. A current limiting resistor has been placed on the Multi Controller to prevent drawing excessive current. A DIL relay operating at 5V, 20mA may be connected to switch heavier loads.

See technical details in Chapters 12 through 16 for connecting LED's.

When the function is an **Input**, connect a switch or a pushbutton to this I/O line. Closing the switch will cause the input to be recognized by Microsoft Flight Simulator or to Project Magenta.

See technical details in Chapters 12 to 16 for connecting switches.

When the function is a **Servo**, you need to connect a gauge with a servo to this I/O line. The “Calibrate” button now becomes active, and you can calibrate the gauge as described on the following pages.

See technical details in Chapters 12 to 16 for connecting servos. And don't forget to connect an external power supply to the Multi Controller to drive the servos!

WARNING !!!

When the calibration is started for the first time for a Multi Controller Board which you have not used to calibrate earlier (you clicked on the button “Calibrate”), the Multi Controller is recognized as a new USB device.

Therefore you must follow once again the steps as described in Chapter 4 on page 10 and 11.

Fail to do so, will cause that you cannot use the Multi Controller as you wish.

This extra USB installation/identification towards Windows is only necessary once.

8. Calibration of connected Gauges (servos)

Since servo motors are used in the gauges, they each need to be calibrated once before using them with Microsoft Flight Simulator, because most of the face plate scales used in aircraft are non-linear. Therefore, the software must “learn” about the scale being used, and will save the created data into a file. The file data is used by the program mclink.exe, which controls the instrument connected to the I/O line. Needless to say, you must have a gauge connected to this I/O line.

The first step of the calibration

By clicking on the calibration button in the previous screen, you entered the calibration routine for a certain instrument.

Function

Here the TRC number selected from the list is shown again for security.

Also, the function description is show again.

Initiate the values

The screen shows 10 input fields and 10 sliders, each numbered from “Step 1” to “Step 10”.

Here you have to enter the values you see on the faceplate of the gauge. In case there are less than 10 values on the gauge faceplate, you need to divide the faceplate into imaginary values. For example, your faceplate only shows 10, 30, 50, 70, 90, you need to find out where values 0, 20, 40, 60 and 80 would be. Now you enter the value “0” (zero) in the first field, 20 in the second field, 30 in the third field and so on. It might be necessary to do some calculations here when you have a faceplate which has a non-linear scale other than a linear scale. Some try and error will help you to get there!

In case your scale calculation doesn't come out to exactly 10 values, you may use a value double. Fore xample when the last value is 100 and you have reached that value in field 9, you may enter the value 100 also in field 10.

Note

When you want to calibrate a gauge like a Vertical Speed Indicator, you will need to enter negative values (for example -20, -15, -10, -5, 0, 0, 5, 10, 15, 20)

Example 1: Calibrating a Vertical Speed Indicator

When calibrating a vertical speed indicator, you need to enter negative as well as positive values in the Value Fields.

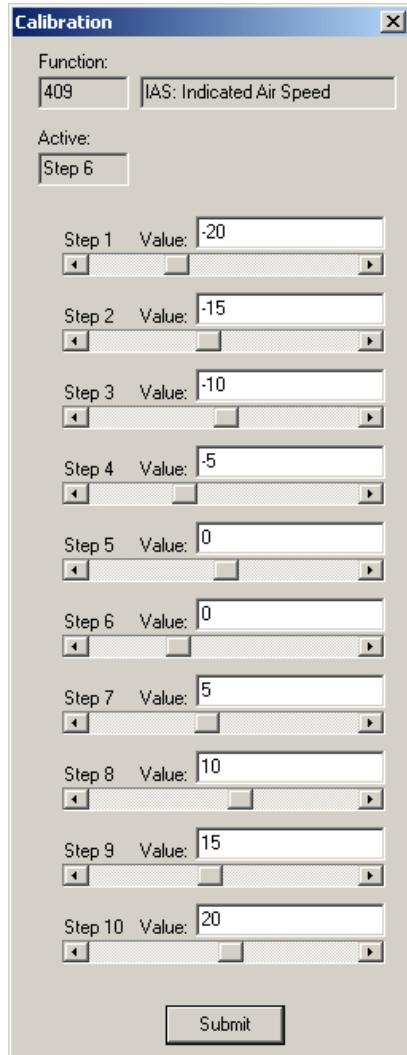

Always start to calibrate clockwise. This means that you must enter the lowest (or most negative) value in the first field and then the next higher (or less negative) value in the subsequent fields.

Prior to entering these values, you should check whether you come to an odd or even amount of values.

In case (as with the VSI) the number of values are odd, you need to enter a certain value twice. In this case the value "0" (zero) needs to be entered twice.

Now use the slider to calibrate the pointer exactly to the position as in the value field given.

For the zero value (entered twice) you have to set the pointer indeed for both "zeros", precisely at "0".

Important:

During calibration, the pointer must always be set clockwise to a new position. Moving the pointer from -20 to +20 the shortest way will give a wrong calibration! When constructing a kit gauge, you should always be sure that the pointer can reach all positions on the faceplate and has some "spare" available on both ends of the scale.



Example 2: Calibrating a 450 knots Airspeed Indicator

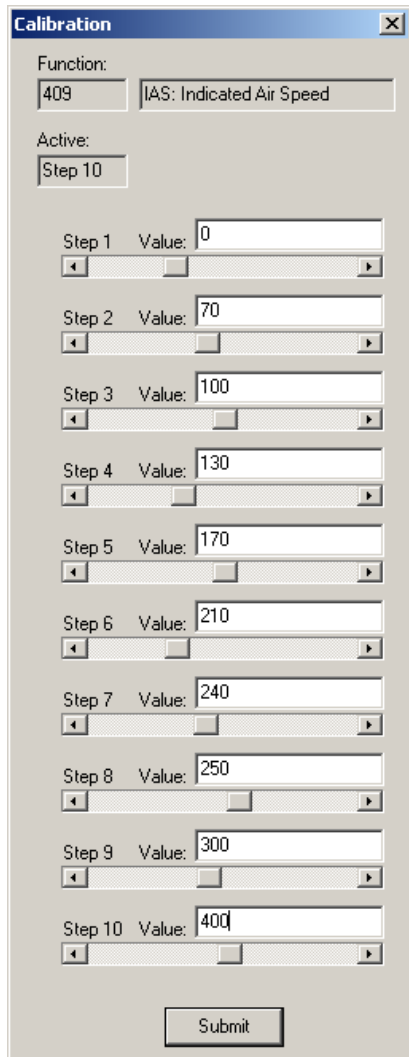

This example uses a 450 knots Airspeed indicator scale as used in an Airliner.

The Airliner ASI scale is partly linear and partly non-linear. Therefore you can set the calibration values for the linear part of the scale in such a way, that the values are in larger steps than the non-linear part.

This example has set the values in such a way, that a proper division between the linear and non-linear values gives the best results.

These values are:
0, 70, 100, 130, 170, 210, 240, 250, 300, 400.

Important:

During calibration, the pointer must always be set clockwise to a new position. Moving the pointer from 0 to 400 the shortest way will give a wrong calibration! When constructin a kit gauge, you should always be sure that the pointer can reach all positions on the faceplate and has some "spare" available on both ends of the scale.

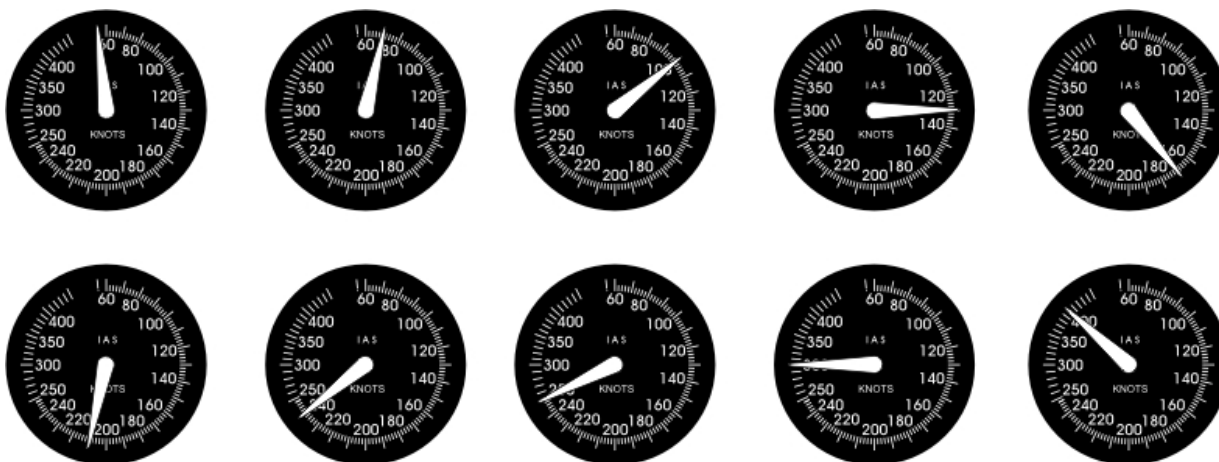

Example 3: calibrating a Flaps Indicator

This example uses a Flaps indicator scale as used in an Airliner .

As the calibration is based on dividing the scale of the gauge into the proper values which come from the flight simulator software, first you have to divide the scale (faceplate) of the gauge into sections from 0 to 100%.

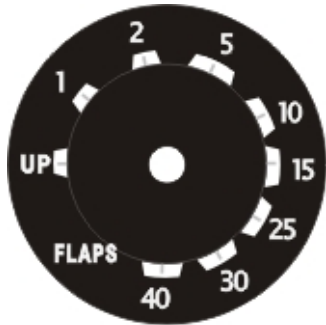

The scale has the following values:

UP (0), 1, 2, 5, 10, 15, 25, 30, 40

As the full path of the pointer - from UP(0) to 40 - has to be divided on the scale as from 0 to 100%, the following table is created:

Scale values	% of scale
UP(0)	0
1	2.5
2	5
5	7.5
10	25
15	37.5
25	62.5
30	75
40	100

Since the calibration table cannot handle fractions, the values behind the decimal point are rounded off.

Since there are only 9 values, the last value is repeated in step 10 (100 entered)

The calibration has to be carried out for each individual pointer.

9. Using the MC Link program

Once you have “identified” the Multi Controller board using the **mnum** program (you should always assign a number to a Multi Controller, even if using only one) and once you have properly calibrated each controller you have connected, you can use the program **mclink** to “connect” the hardware (via FSUIPC) to Microsoft Flight Simulator.

As a reminder, the use of the Multi Controller requires three programs: first, the **mnum.exe** program to assign a number to the Multi Controller; second, the **mccal.exe** program to assign the proper instrument to the Multi Controller and to calibrate it (calibration only needed for gauges), and third, the **mclink.exe** program to “connect” the hardware via FSUIPC to Microsoft Flight Simulator.

For each Multi Controller connected to your PC, you have to run the mclink.exe program.

For example, when you have three Multi Controllers connected via USB to your computer, you should run the mclink.exe program three times. However, there will be a different number in the number field each time. In the example shown, the program shows number 1 in the entry field. The next running of the program should show a different number.

You can assign and start up to 32 Multi Controllers this way. The actual order you use doesn't matter as long as you run the program for each Multi Controllers connected to your PC.

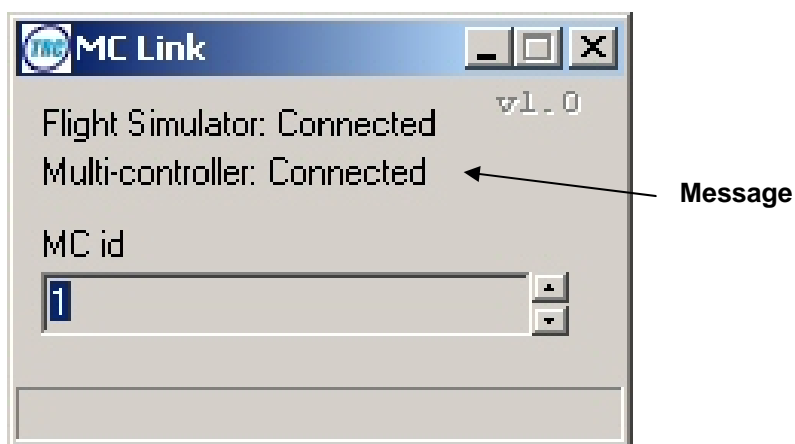

The MC Link window also tells you when the Flight Simulator software is connected, when the Multi Controller is connected, or when the ID is already occupied. The MC Link ID field always defaults to the number one (1). Therefore, if you have previously connected a Multi Controller with an MCLink, at the startup of the next one, the message “Already Occupied” will be displayed, meaning that you have to select a different number. The possible messages are:

“**Already Occupied**” (when number 1, for example, is already in use)

“**Not Connected**” (when for any reason the software cannot connect to a Multi Controller)

“**Connected**” (when the software is properly connected to a Multi Controller).

10. Table of I/O possibilities based on FSUIPC codes

TRC #	Type	Minimum Value	Maximum Value	Units	Functional Description	FSUIPC #
101	I	-	-	-	Alternator (1 = on, 0 = off), read for state, write to control [FS2000+]	3101
102	I	-	-	-	Avionics (1 = on, 0 = off), read for state, write to control [FS2000+]	3103
103	I	-	-	-	Battery (1 = on, 0 = off), read for state, write to control [FS2000+]	3102
104	I	-	-	-	Rotating Beacon	0D0C
105	I	-	-	-	Cabin Lights	0D0C
106	I	-	-	-	Engine 1 Anti-Ice or Carb Heat switch (1=On)	08B2
107	I	-	-	-	Engine 1 Fuel Valve, 1 = open, 2 = closed. Can write to operate. [FS2002+]	3590
108	I	-	-	-	Engine 1 generator switch, a 32-bit BOOL (0 = off, 1= on) [FS2000-FS2004 only]	3B78
109	I	-	-	-	Engine 1 Magnetos (Both)	0892
110	I	-	-	-	Engine 1 Magnetos (Left)	0892
111	I	-	-	-	Engine 1 Magnetos (Right)	0892
112	I	-	-	-	Engine 1 Magnetos (Start)	0892
113	I	-	-	-	Engine 2 Anti-Ice or Carb Heat switch (1=On)	094A
114	I	-	-	-	Engine 2 Fuel Valve, 1 = open, 2 = closed. Can write to operate. [FS2002+]	3594
115	I	-	-	-	Engine 2 generator switch, a 32-bit BOOL (0 = off, 1= on) [FS2000-FS2004 only]	3AB8
116	I	-	-	-	Engine 2 Magnetos (Both)	092A
117	I	-	-	-	Engine 2 Magnetos (Left)	092A
118	I	-	-	-	Engine 2 Magnetos (Right)	092A
119	I	-	-	-	Engine 2 Magnetos (Start)	092A
120	I	-	-	-	Engine 3 Anti-Ice or Carb Heat switch (1=On)	0900
121	I	-	-	-	Engine 3 Fuel Valve, 1 = open, 2 = closed. Can write to operate. [FS2002+]	3598
122	I	-	-	-	Engine 3 generator switch, a 32-bit BOOL (0 = off, 1= on) [FS2000-FS2004 only]	39F8
123	I	-	-	-	Engine 3 Magnetos (Both)	09C2
124	I	-	-	-	Engine 3 Magnetos (Left)	09C2
125	I	-	-	-	Engine 3 Magnetos (Right)	09C2
126	I	-	-	-	Engine 3 Magnetos (Start)	09C2
127	I	-	-	-	Engine 4 Anti-Ice or Carb Heat switch (1=On)	0A7A
128	I	-	-	-	Engine 4 Fuel Valve, 1 = open, 2 = closed. Can write to operate. [FS2002+]	359C

TRC #	Type	Minimum Value	Maximum Value	Units	Functional Description	FSUJPC #
129	I	-	-	-	Engine 4 generator switch, a 32-bit BOOL (0 = off, 1= on) [FS2000-FS2004 only]	3938
130	I	-	-	-	Engine 4 Magnetos (Both)	0A5A
131	I	-	-	-	Engine 4 Magnetos (Left)	0A5A
132	I	-	-	-	Engine 4 Magnetos (Right)	0A5A
133	I	-	-	-	Engine 4 Magnetos (Start)	0A5A
134	I	-	-	-	Engine primer (just write a non-zero byte to operate the primer. This is a one-shot and reading it is meaningless) [FS2000+]	3100
135	I	-	-	-	Fail mode: 0 ok, Engine inoperable = 1, extended for FS2000/CFS2 for up to 4 individual engines: bit 0 =Engine 1 ... bit 3= Engine 4. (but note that this may not work for FS98 aircraft transposed into FS2k/CFS2).	0B6B
136	I	-	-	-	Fail mode: ADF	0B64
137	I	-	-	-	Fail mode: Altimeter	0B66
138	I	-	-	-	Fail mode: ASI	0B65
139	I	-	-	-	Fail mode: Attitude Indicator	0B67
140	I	-	-	-	Fail mode: COM1 radio	0B68
141	I	-	-	-	Fail mode: Direction Indicator	0B6D
142	I	-	-	-	Fail mode: Electronics	0B6A
143	I	-	-	-	Fail mode: Fuel indicators	0B6C
144	I	-	-	-	Fail mode: Mag Compass	0B69
145	I	-	-	-	Fail mode: NAV radios	0B70
146	I	-	-	-	Fail mode: Pitot	0B71
147	I	-	-	-	Fail mode: Transponder	0B6F
148	I	-	-	-	Fail mode: Turn co-ordinator	0B72
149	I	-	-	-	Fail mode: Vacuum	0B73
150	I	-	-	-	Fail mode: VSI	0B6E
151	I	-	-	-	Fuel pump (1 = on, 0 = off), read for state, write to control [FS2000+]. For separate switches for separate fuel pumps see offset 3125.	3104
152	I	-	-	-	Fuel tank selector: All	0AF8
153	I	-	-	-	Fuel tank selector: Centre	0AF8
154	I	-	-	-	Fuel tank selector: Centre 2	0AF8
155	I	-	-	-	Fuel tank selector: Centre 3	0AF8
156	I	-	-	-	Fuel tank selector: Crossfeed LtoR	0AF8
157	I	-	-	-	Fuel tank selector: Crossfeed RtoL	0AF8
158	I	-	-	-	Fuel tank selector: External 1	0AF8
159	I	-	-	-	Fuel tank selector: External 2	0AF8
160	I	-	-	-	Fuel tank selector: Left	0AF8
161	I	-	-	-	Fuel tank selector: Left Tip	0AF8

TRC #	Type	Minimum Value	Maximum Value	Units	Functional Description	FSUJPC #
162	I	-	-	-	Fuel tank selector: Left Aux	0AF8
163	I	-	-	-	Fuel tank selector: Right	0AF8
164	I	-	-	-	Fuel tank selector: Right Tip	0AF8
165	I	-	-	-	Fuel tank selector: Right Aux	0AF8
166	I	-	-	-	Gear control	0BE8
167	I	-	-	-	Instruments	0D0C
168	I	-	-	-	Landing Light	0D0C
169	I	-	-	-	Logo	0D0C
170	I	-	-	-	NAV/GPS switch, in FS2000 & FS2002. 0=NAV, 1=GPS	132C
171	I	-	-	-	Navigation Lights	0D0C
172	I	-	-	-	PANEL AUTOBRAKE SWITCH Read to check setting, write to change it. Brake1	2F80
173	I	-	-	-	PANEL AUTOBRAKE SWITCH Read to check setting, write to change it. Brake2	2F80
174	I	-	-	-	PANEL AUTOBRAKE SWITCH Read to check setting, write to change it. Brake3	2F80
175	I	-	-	-	PANEL AUTOBRAKE SWITCH Read to check setting, write to change it. max	2F80
176	I	-	-	-	PANEL AUTOBRAKE SWITCH Read to check setting, write to change it. RTO	2F80
177	I	-	-	-	PANEL AUTOBRAKE SWITCH Read to check setting, write to change it.Off	2F80
178	I	-	-	-	Panel auto-feather arm switch (0=Off, 1=On)	2E88
179	I	-	-	-	Parking brake	0BC8
180	I	-	-	-	Pause MS-Flightsimulator	0262
181	I	-	-	-	Pitot Heat switch	029C
182	I	-	-	-	Prop sync active (1=Active, 0=Inactive)	2EC8
183	I	-	-	-	Propeller de-ice switch, (1 = on, 0 = off), read for state, write to control [FS2002+]. This should operate with aircraft defined to have the facility, but in fact it merely reflects the older Anti-Ice switch. The TOGGLE_PROP_DEICE control does nothing.	337C
184	I	-	-	-	Recognition	0D0C
185	I	-	-	-	Spoilers arm (0=off, 1=arm for auto deployment)	0BCC
186	I	-	-	-	Strobes	0D0C
187	I	-	-	-	Structural de-ice switch, (1 = on, 0 = off), read for state, write to control [FS2002+]. Although this is documented in both FS2002 and FS2004 panel SDKs, with a token value and an FS control, it appears to do nothing. Possibly it needs some action in the AIR file or Aircraft.CFG, but there's nothing in the official documentation.	337D
188	I	-	-	-	Taxi	0D0C

TRC #	Type	Minimum Value	Maximum Value	Units	Functional Description	FSUJPC #
189	I	-	-	-	Wing	0D0C
201	O	-	-	-	Engine 1 generator active, a 32-bit BOOL (0 = off, 1= on) [FS2000-FS2004 only]	3B7C
202	O	-	-	-	Engine 2 generator active, a 32-bit BOOL (0 = off, 1= on) [FS2000-FS2004 only]	3ABC
203	O	-	-	-	Engine 3 generator active, a 32-bit BOOL (0 = off, 1= on) [FS2000-FS2004 only]	39FC
204	O	-	-	-	Engine 4 generator active, a 32-bit BOOL (0 = off, 1= on) [FS2000-FS2004 only]	393C
205	O	-	-	-	Gear busy indicator	0BE8/ 0BEC/ 0BF0/ 0BF4
206	O	-	-	-	Gear down indicator	0BEC/ 0BF0/ 0BF4
207	O	-	-	-	Gear position (left)	0BF4
208	O	-	-	-	Gear position (nose)	0BEC
209	O	-	-	-	Gear position (right)	0BF0
210	O	-	-	-	Indicator if airplane is on ground	0366
211	O	-	-	-	Inner Marker: activated when TRUE	0BAC
212	O	-	-	-	Middle Marker: activated when TRUE	0BAE
213	O	-	-	-	Outer Marker: activated when TRUE	0BB0
214	O	-	-	-	Overspeed warning	036D
215	O	-	-	-	Stall warning	036C
216	O	-	-	-	"This byte reflects the FS2004 ""Engine on Fire"" flags. I'm not sure if FS actually simulates such events, but it appears to have allocated Gauge-accessible variables to indicate them. Engine 1"	3366
217	O	-	-	-	"This byte reflects the FS2004 ""Engine on Fire"" flags. I'm not sure if FS actually simulates such events, but it appears to have allocated Gauge-accessible variables to indicate them. Engine 2"	3366
218	O	-	-	-	"This byte reflects the FS2004 ""Engine on Fire"" flags. I'm not sure if FS actually simulates such events, but it appears to have allocated Gauge-accessible variables to indicate them. Engine 3"	3366

TRC #	Type	Minimum Value	Maximum Value	Units	Functional Description	FSUIPC #
219	O	-	-	-	"This byte reflects the FS2004 ""Engine on Fire"" flags. I'm not sure if FS actually simulates such events, but it appears to have allocated Gauge-accessible variables to indicate them. Engine 4"	3366
220	O	-	-	-	This byte shows doors that are open (FS2004 only). At present this only provides bit 2^0 for the main doors.	3367
301	S				Aileron position indicator (maybe adjusted from input!)	0BB8
302	S			mach	Airspeed Mach value, double float (FS2002+)	35A0
303	S	-90	+90	degrees	Attitude indicator bank value	2F78
304	S	-25	+25	degrees	Attitude indicator pitch value	2F70
305	S	0	33554432	knots	Barber pole airspeed	02C4
306	S				Braking indicator: brake applied if non-zero (16383=on, 0=off). Note that in FS2002 this is artificially created by FSUIPC from the previous three settings.	0BCA
307	S				Elevator position indicator (maybe adjusted from input!)	0BB4
308	S	-100	+100		Elevator trim indicator (follows input)	0BC2
309	S	0	1000000	Fahrenheit	Engine 1 CHT	08E8
310	S	-18	555538	Celcius	Engine 1 EGT (Celcius)	08BE
311	S	312	1580	Fahrenheit	Engine 1 EGT (Fahrenheit)	08BE
312	S	0	19	gallon/hour	Engine 1 Fuel Flow	0918 / 0AF4
313	S	0	29826161	psi	Engine 1 Fuel pressure, psi	08F8
314	S	0	1073741824	psi	Engine 1 Hydraulic pressure	08D8
315	S	0	100	%	Engine 1 Hydraulic quantity	08DC
316	S	0	65536	rpm	Engine 1 Jet N1: Tachometer	0898 / 08C8
317	S	0	100	%	Engine 1 Jet N2: Turbine RPM %	0896
318	S	0	64	""Hg"	Engine 1 Manifold Pressure	08C0
319	S	0	220	psi	Engine 1 Oil pressure	08BA
320	S	0	100	%	Engine 1 Oil Quantity	08D0
321	S	-18	38	Celcius	Engine 1 Oil temperature (Celcius)	08B8
322	S	75	284	Fahrenheit	Engine 1 Oil temperature (Fahrenheit)	08B8
323	S	0.0	6.4	-	Engine 1 Pressure Ratio	08BC
324	S	0	100	%	Engine 1 Rotor RPM	0908
325	S	0	100	%	Engine 1 Torque	08F4
326	S	0	262144	psi	Engine 1 Transmission oil pressure	0900
327	S	0	262144	Celcius	Engine 1 Transmission oil temperature	0904

TRC #	Type	Minimum Value	Maximum Value	Units	Functional Description	FSUJPC #
328	S	0	4294967296	Celcius	Engine 1 Turbine temperature	08F0
329	S	0,0	5,0	-	Engine 1 Vibration	08D4
330	S	0	1000000	Fahrenheit	Engine 2 CHT	0980
331	S	-18	555538	Celcius	Engine 2 EGT (Celcius)	0956
332	S	312	1580	Fahrenheit	Engine 2 EGT (Fahrenheit)	0956
333	S	0	19	gallon/hour	Engine 2 Fuel Flow	09B0
334	S	0	29826161	psi	Engine 2 Fuel pressure, psi	990
335	S	0	1073741824	psi	Engine 2 Hydraulic pressure	0970
336	S	0	100	%	Engine 2 Hydraulic quantity	0974
337	S	0	65536	rpm	Engine 2 Jet N1: Tachometer	0930 / 0960
338	S	0	100	%	Engine 2 Jet N2: Turbine RPM %	092E
339	S	0	64	""Hg"	Engine 2 Manifold Pressure	0958
340	S	0	220	psi	Engine 2 Oil pressure	0952
341	S	0	100	%	Engine 2 Oil Quantity	0968
342	S	-18	38	Celcius	Engine 2 Oil temperature (Celcius)	0950
343	S	75	284	Fahrenheit	Engine 2 Oil temperature (Fahrenheit)	0950
344	S	0.0	6.4	-	Engine 2 Pressure Ratio	0954
345	S	0	100	%	Engine 2 Rotor RPM	09A0
346	S	0	100	%	Engine 2 Torque	098C
347	S	0	262144	psi	Engine 2 Transmission oil pressure	998
348	S	0	262144	Celcius	Engine 2 Transmission oil temperature	099C
349	S	0	4294967296	Celcius	Engine 2 Turbine temperature	0988
350	S	0,0	5,0	-	Engine 2 Vibration	096C
351	S	0	1000000	Fahrenheit	Engine 3 CHT	0A18
352	S	-18	555538	Celcius	Engine 3 EGT (Celcius)	09EE
353	S	312	1580	Fahrenheit	Engine 3 EGT (Fahrenheit)	09EE
354	S	0	19	gallon/hour	Engine 3 Fuel Flow	0A48
355	S	0	29826161	psi	Engine 3 Fuel pressure, psi	0A28
356	S	0	1073741824	psi	Engine 3 Hydraulic pressure	0A08
357	S	0	100	%	Engine 3 Hydraulic quantity	0A0C
358	S	0	65536	rpm	Engine 3 Jet N1: Tachometer	09C8 / 09F8
359	S	0	100	%	Engine 3 Jet N2: Turbine RPM %	09C6
360	S	0	64	""Hg"	Engine 3 Manifold Pressure	09F0
361	S	0	220	psi	Engine 3 Oil pressure	09EA
362	S	0	100	%	Engine 3 Oil Quantity	0A00
363	S	-18	38	Celcius	Engine 3 Oil temperature (Celcius)	09E8
364	S	75	284	Fahrenheit	Engine 3 Oil temperature (Fahrenheit)	09E8
365	S	0.0	6.4	-	Engine 3 Pressure Ratio	09EC
366	S	0	100	%	Engine 3 Rotor RPM	0A38
367	S	0	100	%	Engine 3 Torque	0A24

TRC #	Type	Minimum Value	Maximum Value	Units	Functional Description	FSUJPC #
368	S	0	262144	psi	Engine 3 Transmission oil pressure	0A30
369	S	0	262144	Celcius	Engine 3 Transmission oil temperature	0A34
370	S	0	4294967296	Celcius	Engine 3 Turbine temperature	0A20
371	S	0,0	5,0	-	Engine 3 Vibration	0A04
372	S	0	1000000	Fahrenheit	Engine 4 CHT	0AB0
373	S	-18	555538	Celcius	Engine 4 EGT (Celcius)	0A86
374	S	312	1580	Fahrenheit	Engine 4 EGT (Fahrenheit)	0A86
375	S	0	19	gallon/hour	Engine 4 Fuel Flow	0AE0
376	S	0	29826161	psi	Engine 4 Fuel pressure, psi	0AC0
377	S	0	1073741824	psi	Engine 4 Hydraulic pressure	0AA0
378	S	0	100	%	Engine 4 Hydraulic quantity	0AA4
379	S	0	65536	rpm	Engine 4 Jet N1: Tachometer	0A60 / 0A90
380	S	0	100	%	Engine 4 Jet N2: Turbine RPM %	0A5E
381	S	0	64	""Hg"	Engine 4 Manifold Pressure	0A88
382	S	0	220	psi	Engine 4 Oil pressure	0A82
383	S	0	100	%	Engine 4 Oil Quantity	0A98
384	S	-18	38	Celcius	Engine 4 Oil temperature (Celcius)	0A80
385	S	75	284	Fahrenheit	Engine 4 Oil temperature (Fahrenheit)	0A80
386	S	0.0	6.4	-	Engine 4 Pressure Ratio	0A84
387	S	0	100	%	Engine 4 Rotor RPM	0AD0
388	S	0	100	%	Engine 4 Torque	0ABC
389	S	0	262144	psi	Engine 4 Transmission oil pressure	0AC8
390	S	0	262144	Celcius	Engine 4 Transmission oil temperature	0ACC
391	S	0	4294967296	Celcius	Engine 4 Turbine temperature	0AB8
392	S	0,0	5,0	-	Engine 4 Vibration	0A9C
393	S	0	100	%	Flaps position indicator (left). Note that in FS2002 and FS2004 this gives the correct proportional amount, with 16383=full deflection. It doesn't correspond to the equally spaced notches used for the control lever. If you know the maximum deflection angle you can derive the current angle by ((max * position indicator) / 16383). Also, in FS2002 and FS2004 this only gives the inboard trailing edge flaps. Please see offsets 30E0-30FF for greater details where needed.	0BE0
394	S	0	100	%	Flaps position indicator (right). Note that in FS2002 and FS2004 this gives the correct proportional amount, with 16384=full deflection. It doesn't correspond to the equally spaced notches used for the control lever. Also, in FS2002 and FS2004 this only gives the inboard trailing edge flaps. Please see offsets 30E0-30FF for greater details where needed.	0BE4

TRC #	Type	Minimum Value	Maximum Value	Units	Functional Description	FSUIPC #
395	S	0	4294967296	gallon	Fuel: centre 2 tank level	1244 / 1248
396	S	0	4294967296	gallon	Fuel: centre 3 tank level	124C / 1250
397	S	0	4294967296	gallon	Fuel: centre tank level	0B74 / 0B78
398	S	0	4294967296	gallon	Fuel: external 1 tank level	1254 / 1258
399	S	0	4294967296	gallon	Fuel: external 2 tank level	125C / 1260
400	S	0	4294967296	gallon	Fuel: left aux tank level	0B84 / 0B88
401	S	0	4294967296	gallon	Fuel: left main tank level	0B7C / 0B80
402	S	0	4294967296	gallon	Fuel: left tip tank level	0B8C / 0B90
403	S	0	4294967296	gallon	Fuel: right aux tank level	0B9C / 0BA0
404	S	0	4294967296	gallon	Fuel: right main tank level	0B94 / 0B98
405	S	0	4294967296	gallon	Fuel: right tip tank level	0BA4 / 0BA8
406	S	0	235935	km/h	GS: Ground Speed	02B4
407	S	0	127394	knots	GS: Ground Speed	02B4
408	S	3	7	""Hg"	Gyro suction (vacuum)	0B18
409	S	0	33554432	knots	IAS: Indicated Air Speed	02BC
410	S	0	65536	Celcius	OAT: Outside Air Temperature (Celcius)	0E8C
411	S	0	117997	Fahrenheit	OAT: Outside Air Temperature (Fahrenheit)	0E8C
412	S				Reciprocating engine 1 carburettor temperature, in degrees Rankine, as a double (FLOAT64). [FSUIPC version 3.401 or later]	3828
413	S				Reciprocating engine 2-carburettor temperature, in degrees Rankine, as a double (FLOAT64). [FSUIPC version 3.401 or later]	3768
414	S				Reciprocating engine 3-carburettor temperature, in degrees Rankine, as a double (FLOAT64). [FSUIPC version 3.401 or later]	36A8
415	S				Reciprocating engine 4-carburettor temperature, in degrees Rankine, as a double (FLOAT64). [FSUIPC version 3.401 or later]	35E8
416	S				Rudder position indicator (maybe adjusted from input!)	0BBC

TRC #	Type	Minimum Value	Maximum Value	Units	Functional Description	FSUJPC #
417	S				Spoiler Left position indicator (0-16383)	0BD4
418	S				Spoiler Right position indicator (0-16383)	0BD8
419	S	0	33554432	knots	TAS: True Air Speed	02B8
420	S	0	65536	Celcius	TAT: Total Air Temperature (Celcius)	11D0
421	S	0	117997	Fahrenheit	TAT: Total Air Temperature (Fahrenheit)	11D0
422	S				Turbine Engine 1 bleed air pressure (pounds per square inch) as a double (FLOAT64). This is for jets and turboprops.	206C
423	S				Turbine Engine 1 EPR as a double (FLOAT64). This is for jets and turboprops.	2030
424	S				Turbine Engine 1 ITT (interstage turbine temperature) in degrees Rankine, as a double (FLOAT64). This is for jets and turboprops.	2038
425	S				Turbine Engine 1 jet thrust, in pounds, as a double (FLOAT64). This is the jet thrust. See 2410 for propeller thrust (turboprops have both).	204C
426	S				Turbine Engine 2 bleed air pressure (pounds per square inch) as a double (FLOAT64). This is for jets and turboprops.	216C
427	S				Turbine Engine 2 EPR as a double (FLOAT64). This is for jets and turboprops.	2130
428	S				Turbine Engine 2 ITT (interstage turbine temperature) in degrees Rankine, as a double (FLOAT64). This is for jets and turboprops.	2138
429	S				Turbine Engine 2 jet thrust, in pounds, as a double (FLOAT64). This is the jet thrust. See 2510 for propeller thrust (turboprops have both).	214C
430	S				Turbine Engine 2-reverser fraction, a double (FLOAT64), in the range 0.0-1.0, providing the reverse as a proportion of the maximum reverse throttle position.	217C
431	S				Turbine Engine 3 bleed air pressure (pounds per square inch) as a double (FLOAT64). This is for jets and turboprops.	226C
432	S				Turbine Engine 3 EPR as a double (FLOAT64). This is for jets and turboprops.	2230
433	S				Turbine Engine 3 ITT (interstage turbine temperature) in degrees Rankine, as a double (FLOAT64). This is for jets and turboprops.	2238
434	S				Turbine Engine 3 jet thrust, in pounds, as a double (FLOAT64). This is the jet thrust. See 2610 for propeller thrust (turboprops have both).	224C

TRC #	Type	Minimum Value	Maximum Value	Units	Functional Description	FSUJPC #
435	S				Turbine Engine 4 bleed air pressure (pounds per square inch) as a double (FLOAT64). This is for jets and turboprops.	236C
436	S				Turbine Engine 4 EPR as a double (FLOAT64). This is for jets and turboprops.	2330
437	S				Turbine Engine 4 ITT (interstage turbine temperature) in degrees Rankine, as a double (FLOAT64). This is for jets and turboprops.	2338
438	S				Turbine Engine 4 jet thrust, in pounds, as a double (FLOAT64). This is the jet thrust. See 2710 for propeller thrust (turboprops have both).	234C
439	S	-45	+45	degrees	Turn co-ordinator (little airplane indicator).	037C
440	S	-120	+120	position	Turn co-ordinator ball position (slip and skid).	036E
441	S	-8388607	+8388608	feet/min	VS: Vertical Speed	02C8
442	S	0	100		Angle of attack	11BE
443	S				Turbine Engine 1 ITT (interstage turbine temperature) in degrees Celcius	2038
444	S				Turbine Engine 1 ITT (interstage turbine temperature) in degrees Fahrenheit	2038
445	S				Turbine Engine 2 ITT (interstage turbine temperature) in degrees Celcius	2138
446	S				Turbine Engine 2 ITT (interstage turbine temperature) in degrees Fahrenheit	2138
447	S				Turbine Engine 3 ITT (interstage turbine temperature) in degrees Celcius	2238
448	S				Turbine Engine 3 ITT (interstage turbine temperature) in degrees Fahrenheit	2238
449	S				Turbine Engine 4 ITT (interstage turbine temperature) in degrees Celcius	2338
450	S				Turbine Engine 4 ITT (interstage turbine temperature) in degrees Fahrenheit	2338

11. Table of I/O possibilities based on Project Magenta codes – table 1

TRC#	Device	min	max	unit	Description	FSUIC#
601	I	-	-	-	Nav aids and modes active in MAP - VOR	04F6
602	I	-	-	-	Nav aids and modes active in MAP - NDB	04F6
603	I	-	-	-	Nav aids and modes active in MAP - ARP	04F6
604	I	-	-	-	Nav aids and modes active in MAP - WPT	04F6
605	I	-	-	-	Nav aids and modes active in MAP - Plan Data boeing - CSTR for airbus	04F6
606	I	-	-	-	Nav aids and modes active in MAP - VOR1 needle Active	04F6
607	I	-	-	-	Nav aids and modes active in MAP - VOR2 needle Active	04F6
608	I	-	-	-	Nav aids and modes active in MAP - Airbus LS Mode Active	04F6
609	I	-	-	-	Nav aids and modes active in MAP - Airbus TRK/FPA Active	04F6
610	I	-	-	-	Nav aids and modes active in MAP - Airbus EXPED Active	04F6
611	I	-	-	-	Nav aids and modes active in MAP - Airbus EXPED Active	04F6
612	I	-	-	-	Electrical Systems Inop - All	0510
613	I	-	-	-	Electrical Systems Inop - Capt PFD	0510
614	I	-	-	-	Electrical Systems Inop - Capt ND	0510
615	I	-	-	-	Electrical Systems Inop - Upper EICAS/ECAM	0510
616	I	-	-	-	Electrical Systems Inop - Lower EICAS/ECAM	0510
617	I	-	-	-	Electrical Systems Inop - F/O PFD	0510
618	I	-	-	-	Electrical Systems Inop - F/O ND	0510
619	I	-	-	-	Electrical Systems Inop - Standby	0510
620	I	-	-	-	Electrical Systems Inop - CDU/MCDU	0510
621	I	-	-	-	Electrical Systems Inop - RCDU/RMCDU	0510
622	I	-	-	-	Electrical Systems Inop - MCP/FCU	0510
623	I	-	-	-	MCP/FCU Buttons B00-31 - SPDP (SPD pushbutton 747 MCP)	5410
624	I	-	-	-	MCP/FCU Buttons B00-31 - HDGP (heading SEL pushbutton 747 MCP)	5410
625	I	-	-	-	MCP/FCU Buttons B00-31 - F/D Copilot On	5410
626	I	-	-	-	MCP/FCU Buttons B00-31 - F/D Copilot Off	5410
627	I	-	-	-	MCP/FCU Buttons B00-31 - ATON (switch on)	5410
628	I	-	-	-	MCP/FCU Buttons B00-31 - ATFF (switch off)	5410
629	I	-	-	-	MCP/FCU Buttons B00-31 - THR	5410
630	I	-	-	-	MCP/FCU Buttons B00-31 - SPD	5410
631	I	-	-	-	MCP/FCU Buttons B00-31 - MACH (spd/mach toggle... C/O, SEL)	5410
632	I	-	-	-	MCP/FCU Buttons B00-31 - FLCH	5410
633	I	-	-	-	MCP/FCU Buttons B00-31 - HDGP (heading SEL pushbutton 747 MCP)	5410
634	I	-	-	-	MCP/FCU Buttons B00-31 - VNAV	5410
635	I	-	-	-	MCP/FCU Buttons B00-31 - LNAV	5410

TRC#	Device	min	max	unit	Description	FSUIC#
636	I	-	-	-	MCP/FCU Buttons B00-31 - LOC	5410
637	I	-	-	-	MCP/FCU Buttons B00-31 - APP	5410
638	I	-	-	-	MCP/FCU Buttons B00-31 - ALT (ALT HOLD!)	5410
639	I	-	-	-	MCP/FCU Buttons B00-31 - VS	5410
640	I	-	-	-	MCP/FCU Buttons B32-63 - AP1	5414
641	I	-	-	-	MCP/FCU Buttons B32-63 - AP2	5414
642	I	-	-	-	MCP/FCU Buttons B32-63 - AP3	5414
643	I	-	-	-	MCP/FCU Buttons B32-63 - FDON (switch on) Captain	5414
644	I	-	-	-	MCP/FCU Buttons B32-63 - FDFE (switch off) Captain	5414
645	I	-	-	-	MCP/FCU Buttons B32-63 - APDI (AP Disengage - not used in 747-400 and 777MCP) <--- 737	5414
646	I	-	-	-	MCP/FCU Buttons B32-63 - APEN (AP Engage - not used in 747-400 and 777 MCP) <--- 737	5414
647	I	-	-	-	MCP/FCU Buttons B32-63 - APOF (AP Disconnect, discreet OFF for 747-400 and 777 MCP)	5414
648	I	-	-	-	MCP/FCU Buttons B32-63 - VS	5414
649	I	-	-	-	MCP/FCU Buttons B32-63 - ALS (AB LS Button Captain)	5414
650	I	-	-	-	MCP/FCU Buttons B32-63 - ASTI (AB STD/QNH push)	5414
651	I	-	-	-	MCP/FCU Buttons B32-63 - ASTO (AB STD/QNH pull -> STD BARO 29.92 in)	5414
652	I	-	-	-	MCP/FCU Buttons B32-63 - ASPI (AB Speed Button push - managed speed mode)	5414
653	I	-	-	-	MCP/FCU Buttons B32-63 - ASPO (AB Speed Button pull)	5414
654	I	-	-	-	MCP/FCU Buttons B32-63 - AHDI (AB Heading Button push - managed heading mode)	5414
655	I	-	-	-	MCP/FCU Buttons B32-63 - AHDO (AB Heading Button pull)	5414
656	I	-	-	-	MCP/FCU Buttons B32-63 - AALI (AB Altitude Button push - managed altitude mode)	5414
657	I	-	-	-	MCP/FCU Buttons B32-63 - AALO (AB Altitude Button pull)	5414
658	I	-	-	-	MCP/FCU Buttons B32-63 - AVSI (AB VS Button push - managed altitude mode)	5414
659	I	-	-	-	MCP/FCU Buttons B32-63 - AVSO (AB VS Button pull)	5414
660	I	-	-	-	MCP/FCU Buttons B32-63 - AEXP (AB EXPED Button)	5414
661	I	-	-	-	MCP/FCU Buttons B32-63 - ATFP (AB TRKFPA Button)	5414
662	I	-	-	-	MCP/FCU Knobs/Selectors S00-31 - DH- (10)	5418
663	I	-	-	-	MCP/FCU Knobs/Selectors S00-31 - DH+ (10)	5418
664	I	-	-	-	MCP/FCU Knobs/Selectors S00-31 - HDG- (1)	5418
665	I	-	-	-	MCP/FCU Knobs/Selectors S00-31 - HDG+ (1)	5418
666	I	-	-	-	MCP/FCU Knobs/Selectors S00-31 - HDG- (10)	5418
667	I	-	-	-	MCP/FCU Knobs/Selectors S00-31 - HDG+ (10)	5418

TRC#	Device	min	max	unit	Description	FSUIPC#
668		-	-	-	MCP/FCU Knobs/Selectors S00-31 - ALT- (100)	5418
669		-	-	-	MCP/FCU Knobs/Selectors S00-31 - ALT+ (100)	5418
670		-	-	-	MCP/FCU Knobs/Selectors S00-31 - ALT- (1000)	5418
671		-	-	-	MCP/FCU Knobs/Selectors S00-31 - ALT+ (1000)	5418
672		-	-	-	MCP/FCU Knobs/Selectors S00-31 - SPD- (1) (mach .01)	5418
673		-	-	-	MCP/FCU Knobs/Selectors S00-31 - SPD+ (1) (mach .01)	5418
674		-	-	-	MCP/FCU Knobs/Selectors S00-31 - SPD- (10) (mach .01)	5418
675		-	-	-	MCP/FCU Knobs/Selectors S00-31 - SPD+ (10) (mach .01)	5418
676		-	-	-	MCP/FCU Knobs/Selectors S00-31 - VS- (100)	5418
677		-	-	-	MCP/FCU Knobs/Selectors S00-31 - VS+ (100)	5418
678		-	-	-	MCP/FCU Knobs/Selectors S00-31 - CRS- (1)	5418
679		-	-	-	MCP/FCU Knobs/Selectors S00-31 - CRS+ (1)	5418
680		-	-	-	MCP/FCU Knobs/Selectors S00-31 - QNH- (0.01/1 depending on mode)	5418
681		-	-	-	MCP/FCU Knobs/Selectors S00-31 - QNH+ (0.01/1 depending on mode)	5418
682		-	-	-	MCP/FCU Knobs/Selectors S00-31 - CRNG- (Captain ND range -)	5418
683		-	-	-	MCP/FCU Knobs/Selectors S00-31 - CRNG+ (Captain ND range +)	5418
684		-	-	-	MCP/FCU Knobs/Selectors S00-31 - CNDM- (Captain ND mode -)	5418
685		-	-	-	MCP/FCU Knobs/Selectors S00-31 - CNDM- (Captain ND mode +)	5418
686		-	-	-	MCP/FCU Knobs/Selectors S00-31 - FRNG- (F/O ND range -)	5418
687		-	-	-	MCP/FCU Knobs/Selectors S00-31 - FRNG+ (F/O ND range +)	5418
688		-	-	-	MCP/FCU Knobs/Selectors S00-31 - FNDM- (F/O ND mode -)	5418
689		-	-	-	MCP/FCU Knobs/Selectors S00-31 - FNDM- (F/O ND mode +)	5418
690		-	-	-	MCP/FCU Knobs/Selectors S32-63 (Captain ND Modes) - CTR (Captain Side ND controls) (also forces new controls)	541C
691		-	-	-	MCP/FCU Knobs/Selectors S32-63 (Captain ND Modes) - APP	541C
692		-	-	-	MCP/FCU Knobs/Selectors S32-63 (Captain ND Modes) - VOR	541C
693		-	-	-	MCP/FCU Knobs/Selectors S32-63 (Captain ND Modes) - MAP	541C
694		-	-	-	MCP/FCU Knobs/Selectors S32-63 (Captain ND Modes) - PLN	541C
695		-	-	-	MCP/FCU Knobs/Selectors S32-63 (Captain ND Modes) - R10	541C
696		-	-	-	MCP/FCU Knobs/Selectors S32-63 (Captain ND Modes) - R20	541C
697		-	-	-	MCP/FCU Knobs/Selectors S32-63 (Captain ND Modes) - R40	541C
698		-	-	-	MCP/FCU Knobs/Selectors S32-63 (Captain ND Modes) - R80	541C
699		-	-	-	MCP/FCU Knobs/Selectors S32-63 (Captain ND Modes) - R160	541C
700		-	-	-	MCP/FCU Knobs/Selectors S32-63 (Captain ND Modes) - R320	541C
701		-	-	-	MCP/FCU Knobs/Selectors S32-63 (Captain ND Modes) - R640	541C
702		-	-	-	MCP/FCU Knobs/Selectors S32-63 (Captain ND Modes) - VOR	541C
703		-	-	-	MCP/FCU Knobs/Selectors S32-63 (Captain ND Modes) - NDB	541C
704		-	-	-	MCP/FCU Knobs/Selectors S32-63 (Captain ND Modes) - WPT	541C
705		-	-	-	MCP/FCU Knobs/Selectors S32-63 (Captain ND Modes) - ARPT	541C

TRC#	Device	min	max	unit	Description	FSUIPC#
706	I	-	-	-	MCP/FCU Knobs/Selectors S32-63 (Captain ND Modes) - DATA	541C
707	I	-	-	-	MCP/FCU Knobs/Selectors S32-63 (Captain ND Modes) - POS	541C
708	I	-	-	-	MCP/FCU Knobs/Selectors S32-63 (Captain ND Modes) - VOR1	541C
709	I	-	-	-	MCP/FCU Knobs/Selectors S32-63 (Captain ND Modes) - ADF1	541C
710	I	-	-	-	MCP/FCU Knobs/Selectors S32-63 (Captain ND Modes) - VORADF1	541C
711	I	-	-	-	MCP/FCU Knobs/Selectors S32-63 (Captain ND Modes) - VOR2	541C
712	I	-	-	-	MCP/FCU Knobs/Selectors S32-63 (Captain ND Modes) - ADF2	541C
713	I	-	-	-	MCP/FCU Knobs/Selectors S32-63 (Captain ND Modes) - VORADF2	541C
714	I	-	-	-	MCP/FCU Knobs/Selectors S32-63 (Captain ND Modes) - METRIC	541C
715	I	-	-	-	MCP/FCU Knobs/Selectors S32-63 (Captain ND Modes) - HDGVS/TRKFPA	541C
716	I	-	-	-	MCP/FCU Knobs/Selectors S32-63 (Captain ND Modes) - THR TOGA	541C
717	I	-	-	-	MCP/FCU Knobs/Selectors S32-63 (Captain ND Modes) - THR FLX/MCT	541C
718	I	-	-	-	MCP/FCU Knobs/Selectors S32-63 (Captain ND Modes) - THR CLB	541C
719	I	-	-	-	MCP/FCU Knobs/Selectors S32-63 (Captain ND Modes) - THR IDLE	541C
720	I	-	-	-	MCP/FCU Knobs/Selectors S32-63 (Captain ND Modes) - THR REV IDLE (THR MAX REV if the current status id THR IDLE REV)	541C
721	I	-	-	-	MCP/FCU Knobs/Selectors S32-63 (Captain ND Modes) - THR MAX REV	541C
722	I	-	-	-	MCP/FCU Knobs/Selectors S64-96 (Captain Side ND controls) - MAP ARC	5420
723	I	-	-	-	MCP/FCU Knobs/Selectors S64-96 (First Officer ND Modes) - MAP CTR	5420
724	I	-	-	-	MCP/FCU Knobs/Selectors S64-96 (First Officer ND Modes) - VOR	5420
725	I	-	-	-	MCP/FCU Knobs/Selectors S64-96 (First Officer ND Modes) - MAP PLAN	5420
726	I	-	-	-	MCP/FCU Knobs/Selectors S64-96 (First Officer ND Modes) - R10	5420
727	I	-	-	-	MCP/FCU Knobs/Selectors S64-96 (First Officer ND Modes) - R20	5420
728	I	-	-	-	MCP/FCU Knobs/Selectors S64-96 (First Officer ND Modes) - R40	5420
729	I	-	-	-	MCP/FCU Knobs/Selectors S64-96 (First Officer ND Modes) - R80	5420
730	I	-	-	-	MCP/FCU Knobs/Selectors S64-96 (First Officer ND Modes) - R160	5420
731	I	-	-	-	MCP/FCU Knobs/Selectors S64-96 (First Officer ND Modes) - R320	5420
732	I	-	-	-	MCP/FCU Knobs/Selectors S64-96 (First Officer ND Modes) - R640	5420
733	I	-	-	-	MCP/FCU Knobs/Selectors S64-96 (First Officer ND Modes) - VOR	5420
734	I	-	-	-	MCP/FCU Knobs/Selectors S64-96 (First Officer ND Modes) - NDB	5420
735	I	-	-	-	MCP/FCU Knobs/Selectors S64-96 (First Officer ND Modes) - WPT	5420
736	I	-	-	-	MCP/FCU Knobs/Selectors S64-96 (First Officer ND Modes) - ARPT	5420
737	I	-	-	-	MCP/FCU Knobs/Selectors S64-96 (First Officer ND Modes) - DATA	5420
738	I	-	-	-	MCP/FCU Knobs/Selectors S64-96 (First Officer ND Modes) - POS	5420
739	I	-	-	-	MCP/FCU Knobs/Selectors S64-96 (First Officer ND Modes) - VOR1	5420
740	I	-	-	-	MCP/FCU Knobs/Selectors S64-96 (First Officer ND Modes) - ADF1	5420
741	I	-	-	-	MCP/FCU Knobs/Selectors S64-96 (First Officer ND Modes) - VORADF1	5420
742	I	-	-	-	MCP/FCU Knobs/Selectors S64-96 (First Officer ND Modes) - VOR2	5420
743	I	-	-	-	MCP/FCU Knobs/Selectors S64-96 (First Officer ND Modes) - ADF2	5420

TRC#	Device	min	max	unit	Description	FSUIPC#
744	I	-	-	-	MCP/FCU Knobs/Selectors S64-96 (First Officer ND Modes) - VORADF2	5420
745	I	-	-	-	MCP/FCU Knobs/Selectors S64-96 (First Officer ND Modes) - METRIC	5420
746	I	-	-	-	Glass Cockpit - Show Controls on engine page	5424
747	I	-	-	-	Glass Cockpit - Show Standby Gauge on engine page	5424
748	I	-	-	-	Glass Cockpit - Engine Page Decrement	5424
749	I	-	-	-	Glass Cockpit - Engine Page Increment	5424
750	I	-	-	-	Glass Cockpit - Synoptic Page Decrement	5424
751	I	-	-	-	Glass Cockpit - Synoptic Page Increment	5424
752	I	-	-	-	Glass Cockpit - PLAN mode selected waypoint Decrement	5424
753	I	-	-	-	Glass Cockpit - PLAN mode selected waypoint Increment	5424
801	O	-	-	-	MCP/FCU Lights - A/P Master L (1)	04F0
802	O	-	-	-	MCP/FCU Lights - A/P Master C (2)	04F0
803	O	-	-	-	MCP/FCU Lights - VS	04F0
804	O	-	-	-	MCP/FCU Lights - ALT HLD	04F0
805	O	-	-	-	MCP/FCU Lights - APP	04F0
806	O	-	-	-	MCP/FCU Lights - LOC	04F0
807	O	-	-	-	MCP/FCU Lights - LNAV	04F0
808	O	-	-	-	MCP/FCU Lights - HDG	04F0
809	O	-	-	-	MCP/FCU Lights - FLCH	04F0
810	O	-	-	-	MCP/FCU Lights - SPD	04F0
811	O	-	-	-	MCP/FCU Lights - THR	04F0
812	O	-	-	-	MCP/FCU Lights - A/T	04F0
813	O	-	-	-	MCP/FCU Lights - F/D	04F0
814	O	-	-	-	MCP/FCU Lights - A/P Master R	04F0
815	O	-	-	-	MCP/FCU Lights - VNAV	04F0
816	O	-	-	-	MCP/FCU Lights - Mach	04F0
817	O	-	-	-	PFD - Windshear	04FE
818	O	-	-	-	PFD - Below G/S	04FE
819	O	-	-	-	PFD - Caution	04FE
820	O	-	-	-	PFD - Warning	04FE
821	O	-	-	-	PFD - Eight Mode ND Active	04FE
822	O	-	-	-	PFD - Seatbelt Sign	04FE
823	O	-	-	-	PFD - No Smoking Sign	04FE
824	O	-	-	-	PFD - Weather Radar (Captain)	04FE
825	O	-	-	-	PFD - EGPWS/Terrain (Captain)	04FE
826	O	-	-	-	PFD - TCAS Active (Captain)	04FE
827	O	-	-	-	PFD - TCAS WARNING	04FE
828	O	-	-	-	PFD - TCAS ALERT	04FE

TRC#	Device	min	max	unit	Description	FSUIC#
829	O	-	-	-	MCP Indications - Blank V/S	051C
830	O	-	-	-	MCP Indications - Blank SPD	051C
831	O	-	-	-	MCP Indications - TOGA *mode* Active	051C
832	O	-	-	-	MCP Indications - QNH set to HPA	051C
833	O	-	-	-	MCP Indications - Metric Display	051C
834	O	-	-	-	MCP Indications - MAP CTR active, AB TRK/FPA	051C
835	O	-	-	-	MCP Indications - (Boeing TOGA Mode, added 20 knts) (Airbus LS Switch Captain)	051C
836	O	-	-	-	MCP Indications - Alt Acquire Mode	051C
837	O	-	-	-	MCP Indications - AB SPD Managed Mode	051C
838	O	-	-	-	MCP Indications - MCP is Minimized	051C
839	O	-	-	-	MCP Indications - GA Mode (MCP)	051C
840	O	-	-	-	GC ND Selected Mode Boeing Captain - APP	051E
841	O	-	-	-	GC ND Selected Mode Boeing Captain - NAV	051E
842	O	-	-	-	GC ND Selected Mode Boeing Captain - MAP	051E
843	O	-	-	-	GC ND Selected Mode Boeing Captain - PLAN	051E
844	O	-	-	-	GC ND Selected Mode Boeing Captain - CTR	051E
845	O	-	-	-	GC ND Selected Mode Boeing First Officer - APP	051E
846	O	-	-	-	GC ND Selected Mode Boeing First Officer - NAV	051E
847	O	-	-	-	GC ND Selected Mode Boeing First Officer - MAP	051E
848	O	-	-	-	GC ND Selected Mode Boeing First Officer - PLAN	051E
849	O	-	-	-	GC ND Selected Mode Boeing First Officer - CTR	051E
850	O	-	-	-	CDU Lights - (EXEC)	052C
851	O	-	-	-	CDU Lights - (MSG)	052C
852	O	-	-	-	CDU Lights - (FAIL)	052C
853	O	-	-	-	CDU Lights - (OFST)	052C
854	O	-	-	-	CDU Lights - Autotune active	052C
855	O	-	-	-	CDU Lights - Next Waypoint	052C
856	O	-	-	-	CDU Lights - Climb	052C
857	O	-	-	-	CDU Lights - Cruise	052C
858	O	-	-	-	CDU Lights - Descent	052C
859	O	-	-	-	CDU Lights - TOD in 50 Miles	052C
860	O	-	-	-	CDU Lights - TOD	052C
861	O	-	-	-	CDU Lights - TOD less than 50 Miles	052C
862	O	-	-	-	CDU Lights - CDU is minimized	052C
863	O	-	-	-	CDU Lights - Position Init Completed ATT/MAP off - ALIGN IRS set in MCDU	052C
901	S	0	32767	knots	MCP/FCU IAS	04e0
902	S	-32767	32767	FPA	MCP/FCU Selected Vertical Speed	04e6
903	S	0	32767	Mach	MCP/FCU Mach	04e8

TRC#	Device	min	max	unit	Description	FSUIC#
904	S				Cabin Temperature (factor 0.1)	567E
905	S				Cabin Climb (factor 10)	56A4
906	S				Cabin Alt (factor 10)	56A6

12. Table of I/O possibilities based on Project Magenta codes / Table 2

TRC#	Device	min	max	unit	Description	FSUIPC#
1001	I	-	-	-	PSEU	04F1
1002	I	-	-	-	pmMainElectInop	0510
1003	I	-	-	-	pmCaptPFDInop	0510
1004	I	-	-	-	pmCaptNDInop	0510
1005	I	-	-	-	pmSD1Inop	0510
1006	I	-	-	-	pmSD2Inop	0510
1007	I	-	-	-	pmFOPFDInop	0510
1008	I	-	-	-	pmFONDInop	0510
1009	I	-	-	-	pmCDUInop	0511
1010	I	-	-	-	pmRCDUInop	0511
1011	I	-	-	-	pmAPIInop	0511
1012	I	-	-	-	fsNavlight	0D0C
1013	I	-	-	-	fsBeacon	0D0C
1014	I	-	-	-	fsLandLight	0D0C
1015	I	-	-	-	fsTaxilight	0D0C
1016	I	-	-	-	fsStrobe	0D0C
1017	I	-	-	-	fsRecognitionLight	0D0C
1018	I	-	-	-	fsWingLight	0D0C
1019	I	-	-	-	fsLogoLight	0D0D
1020	I	-	-	-	SixPackFire	5530
1021	I	-	-	-	SixPackCaution	5530
1022	I	-	-	-	SixPackFltCont	5530
1023	I	-	-	-	SixPackElec	5530
1024	I	-	-	-	SixPackIRS	5530
1025	I	-	-	-	SixPackAPU	5530
1026	I	-	-	-	SixPackAntilce	5531
1027	I	-	-	-	SixPackHyd	5531
1028	I	-	-	-	APUMasterFault	5600
1029	I	-	-	-	APUStartAvail	5600
1030	I	-	-	-	APUFlap	5600
1031	I	-	-	-	APUMaint / APUSarter	5600
1032	I	-	-	-	APULowPress	5600
1033	I	-	-	-	APUPumpFault	5600
1034	I	-	-	-	APUFault	5600
1035	I	-	-	-	APUGenBus	5600
1036	I	-	-	-	APUMasterOn	5601
1037	I	-	-	-	APUPump1	560C
1038	I	-	-	-	APUPump2	560C
1039	I	-	-	-	ManEngN11	5615

TRC#	Device	min	max	unit	Description	FSUIPC#
1040	I	-	-	-	ManEngN12	5615
1041	I	-	-	-	ManEngN13	5615
1042	I	-	-	-	ManEngN14	5615
1043	I	-	-	-	EngAuto	5615
1044	I	-	-	-	ConStart	5615
1045	I	-	-	-	IgnArm1	5615
1046	I	-	-	-	IgnArm2	5615
1047	I	-	-	-	Cutoff1 / CutoffL	561A
1048	I	-	-	-	Cutoff2 / CutoffR	561A
1049	I	-	-	-	Cutoff1Show / CutoffLShow	561A
1050	I	-	-	-	Cutoff2Show / CutoffRShow	561A
1051	I	-	-	-	Cutoff3	561A
1052	I	-	-	-	Cutoff4	561A
1053	I	-	-	-	Cutoff3Show	561A
1054	I	-	-	-	Cutoff4Show	561A
1055	I	-	-	-	EngValve1 /737 engine/spar valve lights	561B
1056	I	-	-	-	EngValve2	561B
1057	I	-	-	-	SparValve1	561B
1058	I	-	-	-	SparValve2	561B
1059	I	-	-	-	GenBus1	561D
1060	I	-	-	-	GenBus2	561D
1061	I	-	-	-	GenBus3	561D
1062	I	-	-	-	GenBus4	561D
1063	I	-	-	-	ACCESSFeed	561E
1064	I	-	-	-	Galley	561E
1065	I	-	-	-	StandbyPowerFault /light for standby power 737	561E
1066	I	-	-	-	UtilityL	561E
1067	I	-	-	-	UtilityR	561E
1068	I	-	-	-	UtilityLOff	561E
1069	I	-	-	-	UtilityROff	561E
1070	I	-	-	-	Gen1Fault	561F
1071	I	-	-	-	Gen2Fault	561F
1072	I	-	-	-	APUGenFault	561F
1073	I	-	-	-	APUGen2Fault	561F
1074	I	-	-	-	IDG1Fault	561F
1075	I	-	-	-	IDG2Fault	561F
1076	I	-	-	-	GalleyFault	561F
1077	I	-	-	-	ACCESSFeedFault	561F
1078	I	-	-	-	ElecBus1	5626
1079	I	-	-	-	ElecBus2	5626
1080	I	-	-	-	ElecBus3	5626
1081	I	-	-	-	ElecBus4	5626

TRC#	Device	min	max	unit	Description	FSUIPC#
1082	I	-	-	-	ApuBus1	5626
1083	I	-	-	-	ApuBus2	5626
1084	I	-	-	-	ExtBus	5626
1085	I	-	-	-	Batt1Fault	5627
1086	I	-	-	-	Batt2Fault	5627
1087	I	-	-	-	ApuBattFault	5627
1088	I	-	-	-	Gen3Fault	5627
1089	I	-	-	-	Gen4Fault	5627
1090	I	-	-	-	ApuBatt //330340	5627
1091	I	-	-	-	Batt1	5628
1092	I	-	-	-	Batt2	5628
1093	I	-	-	-	BusTie1 // 747 777	5628
1094	I	-	-	-	BusTie2 // 747 777	5628
1095	I	-	-	-	BusTie3 // 747	5628
1096	I	-	-	-	BusTie4 // 747	5628
1097	I	-	-	-	ExtPwrAvail	562A
1098	I	-	-	-	ExtPwrAvail2	562A
1099	I	-	-	-	ExtPwrOn1 // when a second one is needed	562A
1100	I	-	-	-	ExtPwrOn2 // when a second one is needed	562A
1101	I	-	-	-	ExtPwrTaxi	562A
1102	I	-	-	-	BusTieOff1 // 747 777	562B
1103	I	-	-	-	BusTieOff2 // 747 777	562B
1104	I	-	-	-	BusTieOff3 // 747	562B
1105	I	-	-	-	BusTieOff4 // 747	562B
1106	I	-	-	-	ExtPwrDisp1	562B
1107	I	-	-	-	ExtPwrDisp2	562B
1108	I	-	-	-	ApuPwrDisp1	562B
1109	I	-	-	-	ApuPwrDisp2	562B
1110	I	-	-	-	DCBusAvail / pmDisp1 // Display Handling Variables 737 Batt AC/DC	562C
1111	I	-	-	-	ACBusAvail / pmDisp2	562C
1112	I	-	-	-	pmDisp3	562C
1113	I	-	-	-	pmDisp4	562C
1114	I	-	-	-	DCService	562C
1115	I	-	-	-	SSBus / TransBus1	5635
1116	I	-	-	-	TransBus2	5635
1117	I	-	-	-	DCBusUse / Source1Off	5635
1118	I	-	-	-	ACBusUse / Source2Off	5635
1119	I	-	-	-	Drive1	5635
1120	I	-	-	-	Drive2	5635
1121	I	-	-	-	Drive3	5635
1122	I	-	-	-	Drive4	5635
1123	I	-	-	-	pwr1	5637

TRC#	Device	min	max	unit	Description	FSUIPC#
1124	I	-	-	-	pwr2	5637
1125	I	-	-	-	pwr3	5637
1126	I	-	-	-	pwr4	5637
1127	I	-	-	-	BattDischarge	563B
1128	I	-	-	-	TRUnitFault	563B
1129	I	-	-	-	ExtPwrActive	563B
1130	I	-	-	-	ElecFault	563B
1131	I	-	-	-	DCBusInUse	563B
1132	I	-	-	-	ACBusInUse	563B
1133	I	-	-	-	RwyTurnoffLightL	5642
1134	I	-	-	-	RwyTurnoffLightR	5642
1135	I	-	-	-	LandLightL	5642
1136	I	-	-	-	LandLightR	5642
1137	I	-	-	-	LandLightLOut	5642
1138	I	-	-	-	LandLightROut	5642
1139	I	-	-	-	OverheadLight	5642
1140	I	-	-	-	IceIndLight	5642
1141	I	-	-	-	WheelWellLight	5643
1142	I	-	-	-	NoseLight	5643
1143	I	-	-	-	Beacon	5643
1144	I	-	-	-	TaxiLight	5643
1145	I	-	-	-	LogoLight	5643
1146	I	-	-	-	WingLight	5643
1147	I	-	-	-	NavLight / StormLight	5643
1148	I	-	-	-	PanelLight	5643
1149	I	-	-	-	GroundCall	5646
1150	I	-	-	-	AttendCall	5646
1151	I	-	-	-	FireDet1	564A
1152	I	-	-	-	FireDet2	564A
1153	I	-	-	-	FireDet3	564A
1154	I	-	-	-	FireDet4	564A
1155	I	-	-	-	FireDet5	564A
1156	I	-	-	-	FireDetTest	564A
1157	I	-	-	-	FireBottTest	564A
1158	I	-	-	-	FireBott1	564B
1159	I	-	-	-	FireBott2	564B
1160	I	-	-	-	FireBott3	564B
1161	I	-	-	-	GPWSTerrOff	564E
1162	I	-	-	-	GPWSSysOff	564E
1163	I	-	-	-	GPWSGSOff	564E
1164	I	-	-	-	GPWSFlapOff	564E
1165	I	-	-	-	GPWSFlap3Off	564E

TRC#	Device	min	max	unit	Description	FSUIPC#
1166	I	-	-	-	GPWSGndOff	564E
1167	I	-	-	-	CabinUtil	564F
1168	I	-	-	-	IFEVideo	564F
1169	I	-	-	-	ANNLight	5650
1170	I	-	-	-	EmerExitLight	5650
1171	I	-	-	-	EquipCoolFail	5656
1172	I	-	-	-	AntilceD1	5656
1173	I	-	-	-	AntilceD2	5656
1174	I	-	-	-	AntilceWing	5657
1175	I	-	-	-	AntilceWing2	5657
1176	I	-	-	-	AntilceEng1	5657
1177	I	-	-	-	AntilceEng2	5657
1178	I	-	-	-	AntilceEng3	5657
1179	I	-	-	-	AntilceEng4	5657
1180	I	-	-	-	RainRPLNTL	5662
1181	I	-	-	-	RainRPLNTR	5662
1182	I	-	-	-	WasherL	5662
1183	I	-	-	-	WasherR	5662
1184	I	-	-	-	ProbeHeat	5664
1185	I	-	-	-	ProbeHeatR	5664
1186	I	-	-	-	LPitotFail	566B
1187	I	-	-	-	LPitotFail2	566B
1188	I	-	-	-	RPitotFail	566B
1189	I	-	-	-	RPitotFail2	566B
1190	I	-	-	-	Pack1Fault	5677
1191	I	-	-	-	Pack2Fault	5677
1192	I	-	-	-	Pack3Fault	5677
1193	I	-	-	-	Pack4Fault	5677
1194	I	-	-	-	Eng1Bleed	5678
1195	I	-	-	-	Eng2Bleed	5678
1196	I	-	-	-	Eng3Bleed	5678
1197	I	-	-	-	Eng4Bleed	5678
1198	I	-	-	-	APUBleed	5678
1199	I	-	-	-	Eng1BleedFault	5679
1200	I	-	-	-	Eng2BleedFault	5679
1201	I	-	-	-	Eng3BleedFault	5679
1202	I	-	-	-	Eng4BleedFault	5679
1203	I	-	-	-	ApuBleedFault	5679
1204	I	-	-	-	HotAirFault	5679
1205	I	-	-	-	DualBleed	5679
1206	I	-	-	-	HotAir1 (A3340330) / TrimAirL (777)	5683
1207	I	-	-	-	HotAir2 (A3340330) / TrimAirR (777)	5683

TRC#	Device	min	max	unit	Description	FSUIPC#
1208		-	-	-	BleedISLNAutoL (777) / BleedIsolation1 (747)	5688
1209		-	-	-	BleedISLNAutoC / BleedIsolation2 (747)	5688
1210		-	-	-	BleedISLNAutoR	5688
1211		-	-	-	BleedISLNL	5688
1212		-	-	-	BleedISLNC	5688
1213		-	-	-	BleedISLNR	5688
1214		-	-	-	RecirculationL //L RECIRC FAN	5689
1215		-	-	-	RecirculationR //R RECIRC FAN	5689
1216		-	-	-	Bleed1Val	5690
1217		-	-	-	Bleed2Val	5692
1218		-	-	-	Bleed3Val	5694
1219		-	-	-	Bleed4Val	5696
1220		-	-	-	Bleed1ref	5698
1221		-	-	-	Bleed2ref	569A
1222		-	-	-	Bleed3ref	569C
1223		-	-	-	Bleed4ref	569E
1224		-	-	-	CargoFwdSmoke	56A0
1225		-	-	-	CargoAftSmoke	56A0
1226		-	-	-	Batt1Cover	56A1
1227		-	-	-	SRACover	56A1
1228		-	-	-	SRBCover	56A1
1229		-	-	-	SBPCover	56A1
1230		-	-	-	BusTieCover	56A1
1231		-	-	-	EmerExitCover	56A1
1232		-	-	-	AlternFlapsCover	56A1
1233		-	-	-	SpoilerACover	56A2
1234		-	-	-	SpoilerBCover	56A2
1235		-	-	-	Drive1Cover	56A2
1236		-	-	-	Drive2Cover	56A2
1237		-	-	-	ValveComp	56AF
1238		-	-	-	Fwd1PumpFault	56B0
1239		-	-	-	Fwd2PumpFault	56B0
1240		-	-	-	Aft1PumpFault	56B0
1241		-	-	-	Aft2PumpFault	56B0
1242		-	-	-	Ctr1PumpFault	56B0
1243		-	-	-	Ctr2PumpFault	56B0
1244		-	-	-	Stab1PumpFault	56B0
1245		-	-	-	Stab2PumpFault	56B0
1246		-	-	-	Fwd1Pump	56B1
1247		-	-	-	Fwd2Pump	56B1
1248		-	-	-	Aft1Pump	56B1
1249		-	-	-	Aft2Pump	56B1

TRC#	Device	min	max	unit	Description	FSUIPC#
1250	I	-	-	-	Ctr1Pump	56B1
1251	I	-	-	-	Ctr2Pump	56B1
1252	I	-	-	-	Stab1Pump	56B1
1253	I	-	-	-	Stab2Pump	56B1
1254	I	-	-	-	FuelCrossFeed	56B2
1255	I	-	-	-	FuelModeSel	56B2
1256	I	-	-	-	FuelCrossFeed2 / FuelCrossFeedHi	56B2
1257	I	-	-	-	FuelCrossFeed3 / FuelCrossFeedLo	56B2
1258	I	-	-	-	FuelCrossFeed4	56B2
1259	I	-	-	-	CrossFeedOpen2	56B2
1260	I	-	-	-	CrossFeedOpen3	56B2
1261	I	-	-	-	CrossFeedOpen4	56B2
1262	I	-	-	-	CrossFeedOpen	56B3
1263	I	-	-	-	FuelModeFault	56B3
1264	I	-	-	-	FuelXfr	56B3
1265	I	-	-	-	FuelXfrFault	56B3
1266	I	-	-	-	AuxFuelXferAFwd	56B3
1267	I	-	-	-	AuxFuelXferBFwd	56B3
1268	I	-	-	-	AuxFuelXferAAft	56B3
1269	I	-	-	-	AuxFuelXferBAft	56B3
1270	I	-	-	-	Fwd2PumpAux	56B4
1271	I	-	-	-	Fwd3Pump	56B4
1272	I	-	-	-	Aft2PumpAux	56B4
1273	I	-	-	-	Aft3Pump	56B4
1274	I	-	-	-	Fwd3PumpAux	56B4
1275	I	-	-	-	Aft3PumpAux	56B4
1276	I	-	-	-	Fwd4Pump	56B4
1277	I	-	-	-	Aft4Pump	56B4
1278	I	-	-	-	Fwd2PumpAuxFault	56B5
1279	I	-	-	-	Fwd3PumpFault	56B5
1280	I	-	-	-	Aft2PumpAuxFault	56B5
1281	I	-	-	-	Aft3PumpFault	56B5
1282	I	-	-	-	Fwd3PumpAuxFault	56B5
1283	I	-	-	-	Aft3PumpAuxFault	56B5
1284	I	-	-	-	Fwd4PumpFault	56B5
1285	I	-	-	-	Aft4PumpFault	56B5
1286	I	-	-	-	SEC1 //Airbus	56CB
1287	I	-	-	-	SEC2	56CB
1288	I	-	-	-	SEC3	56CB
1289	I	-	-	-	ELAC1	56CB
1290	I	-	-	-	ELAC2	56CB
1291	I	-	-	-	FAC1	56CB

TRC#	Device	min	max	unit	Description	FSUIPC#
1292	I	-	-	-	FAC2	56CB
1293	I	-	-	-	SEC1Fault //Airbus	56CC
1294	I	-	-	-	SEC2Fault	56CC
1295	I	-	-	-	SEC3Fault	56CC
1296	I	-	-	-	ELAC1Fault	56CC
1297	I	-	-	-	ELAC2Fault	56CC
1298	I	-	-	-	FAC1Fault	56CC
1299	I	-	-	-	FAC2Fault	56CC
1300	I	-	-	-	ADR1 //Airbus	56CD
1301	I	-	-	-	ADR2	56CD
1302	I	-	-	-	ADR3	56CD
1303	I	-	-	-	IR1	56CD
1304	I	-	-	-	IR2	56CD
1305	I	-	-	-	IR3	56CD
1306	I	-	-	-	ADR1Fault //Airbus	56CE
1307	I	-	-	-	ADR2Fault	56CE
1308	I	-	-	-	ADR3Fault	56CE
1309	I	-	-	-	IR1Fault	56CE
1310	I	-	-	-	IR2Fault	56CE
1311	I	-	-	-	IR3Fault	56CE
1312	I	-	-	-	IROnBat	56CE
1313	I	-	-	-	HydEng1Fault	56D0
1314	I	-	-	-	HydElec1Fault / HydEng1Press (747)	56D0
1315	I	-	-	-	HydEng2Fault	56D0
1316	I	-	-	-	HydElec2Fault / HydEng2Press	56D0
1317	I	-	-	-	HydEng3Fault	56D0
1318	I	-	-	-	HydEng4Fault	56D0
1319	I	-	-	-	HydEng3Press	56D0
1320	I	-	-	-	HydEng4Press	56D0
1321	I	-	-	-	HydEng1	56D1
1322	I	-	-	-	HydEng2	56D1
1323	I	-	-	-	HydEng3	56D1
1324	I	-	-	-	HydEng4	56D1
1325	I	-	-	-	HydElec1	56D1
1326	I	-	-	-	HydElec2	56D1
1327	I	-	-	-	HydPTU	56D1
1328	I	-	-	-	HydElec3	56D1
1329	I	-	-	-	Hyd3A	56D4
1330	I	-	-	-	SpoilerA	56E2
1331	I	-	-	-	SpoilerB	56E2
1332	I	-	-	-	AlternFlaps	56E2
1333	I	-	-	-	StbyHydLowQ	56E2

TRC#	Device	min	max	unit	Description	FSUIPC#
1334	I	-	-	-	StbyHydLowP	56E2
1335	I	-	-	-	StbyRuddOn	56E2
1336	I	-	-	-	WindowHeatSL	56E4
1337	I	-	-	-	WindowHeatFL	56E4
1338	I	-	-	-	WindowHeatFR	56E4
1339	I	-	-	-	WindowHeatSR	56E4
1340	I	-	-	-	WindowHeatSLOn	56E5
1341	I	-	-	-	WindowHeatFLOn	56E5
1342	I	-	-	-	WindowHeatFROn	56E5
1343	I	-	-	-	WindowHeatSROn	56E5
1344	I	-	-	-	WindowOverHeatSL	56E6
1345	I	-	-	-	WindowOverHeatFL	56E6
1346	I	-	-	-	WindowOverHeatFR	56E6
1347	I	-	-	-	WindowOverHeatSR	56E6
1348	I	-	-	-	YawDampFault	56F0
1349	I	-	-	-	CtrlLowPressA	56F0
1350	I	-	-	-	CtrlLowPressB	56F0
1351	I	-	-	-	FeelDiffPress	56F0
1352	I	-	-	-	YawDamperFault	56F0
1353	I	-	-	-	MachTrimFail	56F0
1354	I	-	-	-	SpeedTrimFail	56F0
1355	I	-	-	-	AutoSlatFail	56F0
1356	I	-	-	-	PDoor1	56F1
1357	I	-	-	-	PDoor2	56F1
1358	I	-	-	-	PDoor3	56F1
1359	I	-	-	-	PDoor4	56F1
1360	I	-	-	-	PDoor5	56F1
1361	I	-	-	-	PDoor6	56F1
1362	I	-	-	-	CDoor1	56F2
1363	I	-	-	-	CDoor2	56F2
1364	I	-	-	-	CDoor3	56F2
1365	I	-	-	-	CDoor4	56F2
1366	I	-	-	-	SDoor1	56F2
1367	I	-	-	-	SDoor2	56F2
1368	I	-	-	-	SDoor3	56F2
1369	I	-	-	-	SDoor4	56F2
1370	I	-	-	-	Caution	56F3
1371	I	-	-	-	CautionSwitch	56F3
1372	I	-	-	-	Eng1	56F4
1373	I	-	-	-	Eng2	56F4
1374	I	-	-	-	Eng3	56F4
1375	I	-	-	-	Eng4	56F4

TRC#	Device	min	max	unit	Description	FSUIPC#
1376	I	-	-	-	Batt1Mom	56F6
1377	I	-	-	-	Batt2Mom	56F6
1378	I	-	-	-	ApuMasterOnMom	56F6
1379	I	-	-	-	ApuStartOnMom	56F6
1380	I	-	-	-	ApuGenMom	56F6
1381	I	-	-	-	Testbit	56F9

13. How to connect instruments to the I/O lines of the Multi Controller

The Multi Controller has 23 I/O lines, which are connected to all three I/O connectors.

You may only connect one instrument to each of the I/O lines. For example, if you have connected an LED to the Output Connector on line 18, the Input Connector line 18 and the SERVO Connector line 18 must be left open (see the following photo).

Input Connector (2 x 25 pins) Output Connector (2 x 25 pins) Servo Connector (3 x 23 pins)

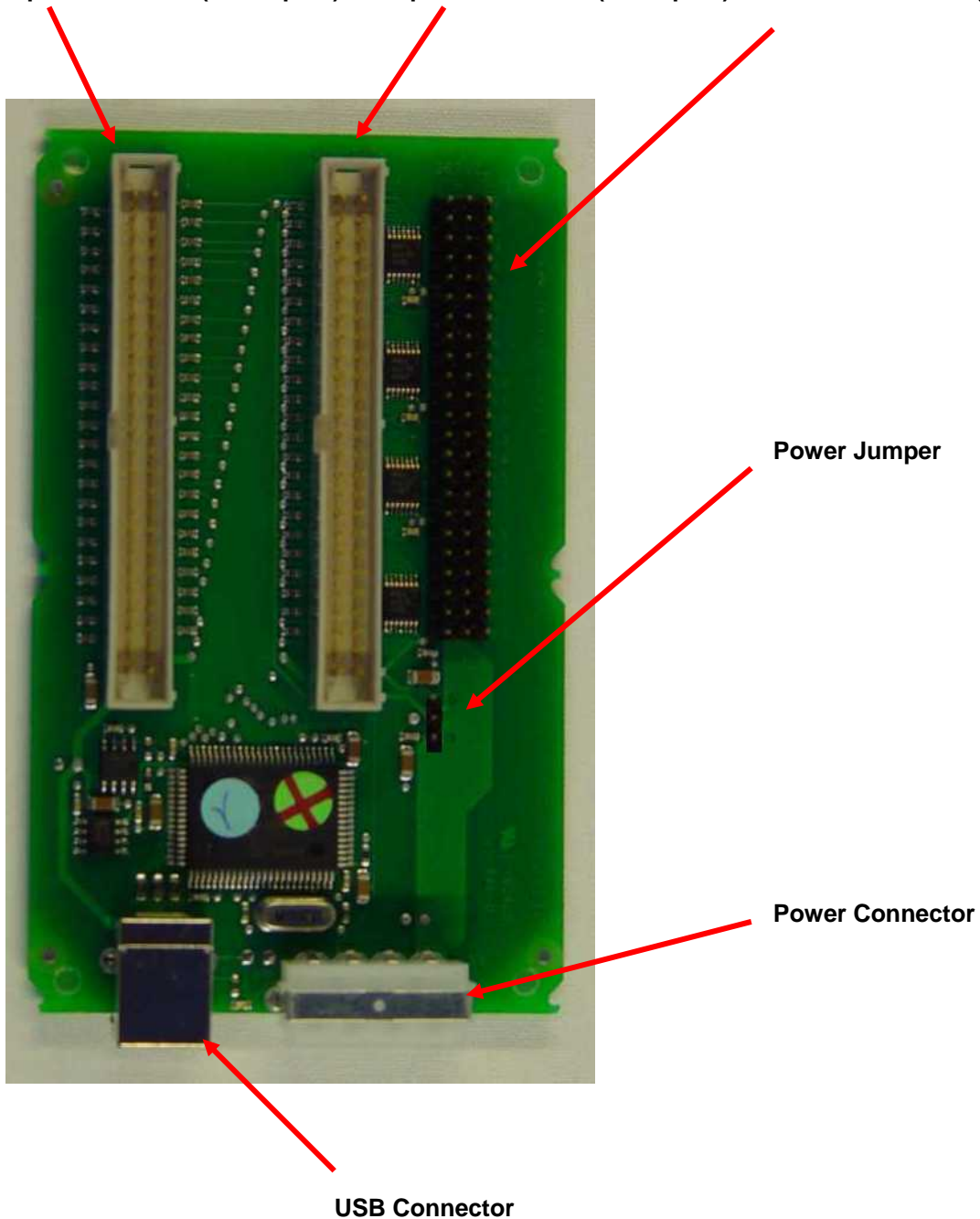

14. Hardware pin assignment of the Multi Controller

The Multi Controller has three rows of connectors, one for inputs, one for outputs and one for servos. You may also wish to visit the Simkits website for add-on boards for the Multi Controller.

Note: Use caution when handling electronics, especially under dry or freezing conditions, as static electricity can damage the board. This type of damage is not covered by warranty!

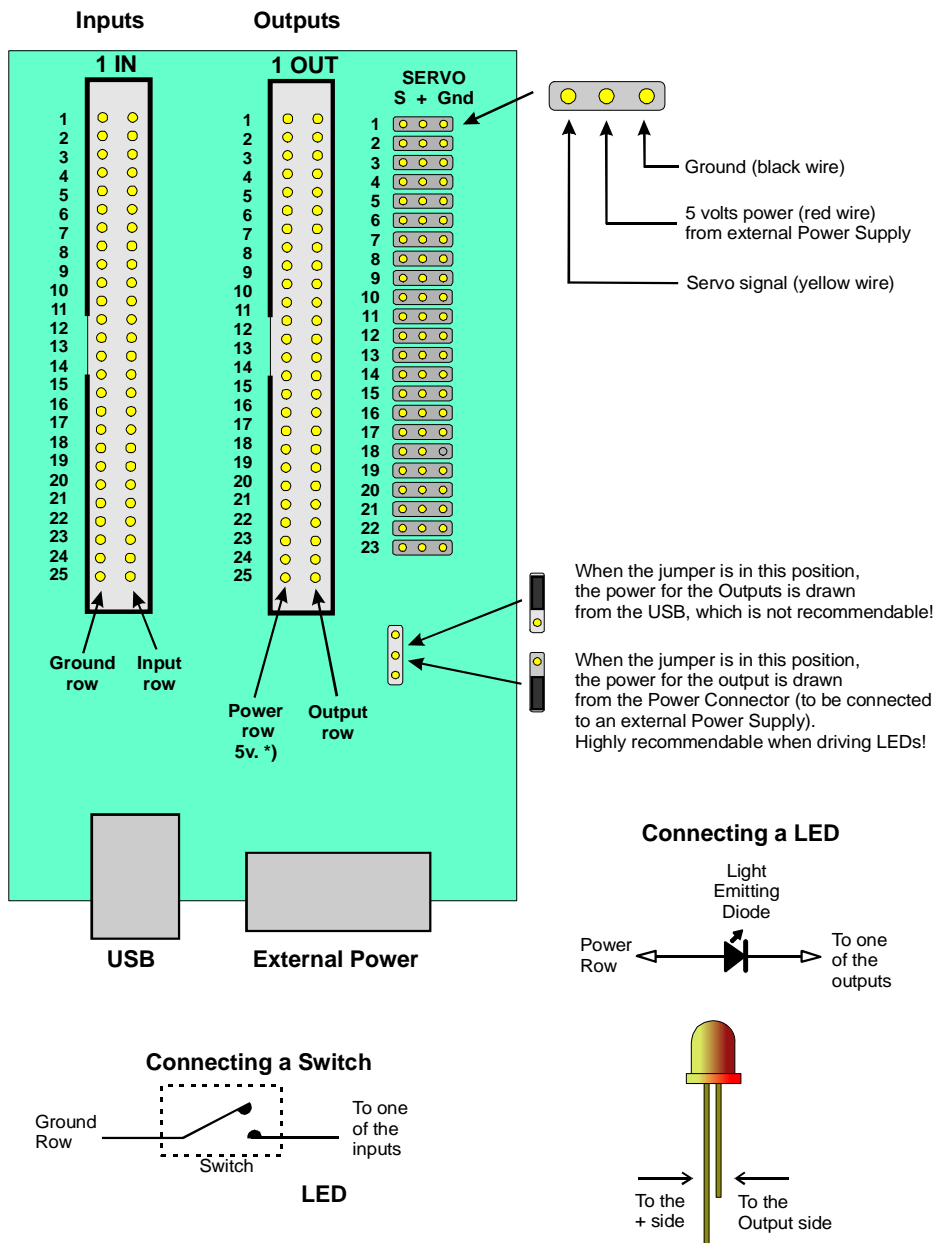

Note: Pins 47 and 49 on the Output connector are Ground

Pins 48 and 50 on the Input connector and Output connector are +5v from the USB connector

15. How to connect Switches, LED's and Gauges (Servos) correctly

The Multi Controller has 23 I/O lines, each I/O line being connected in parallel to three connectors. Only one (1) connection at a time may be used on each I/O line.

For example: You'd like to connect a switch, an LED and a servo to the Multi Controller.

- Connect the switch to the Input connector on row 1.
- Connect the LED to the Output connector on row 2.
- Connect the servo to the SERVO connector on row 3.

(refer to the following diagrams)

Example 1 - Do not connect like this!!!

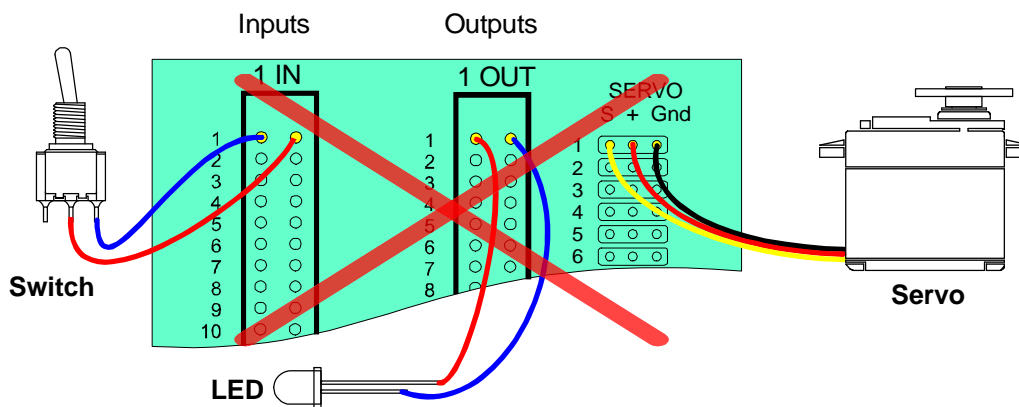

Never connect 3 instruments to the same row!

Example 2 - This is how to connect!

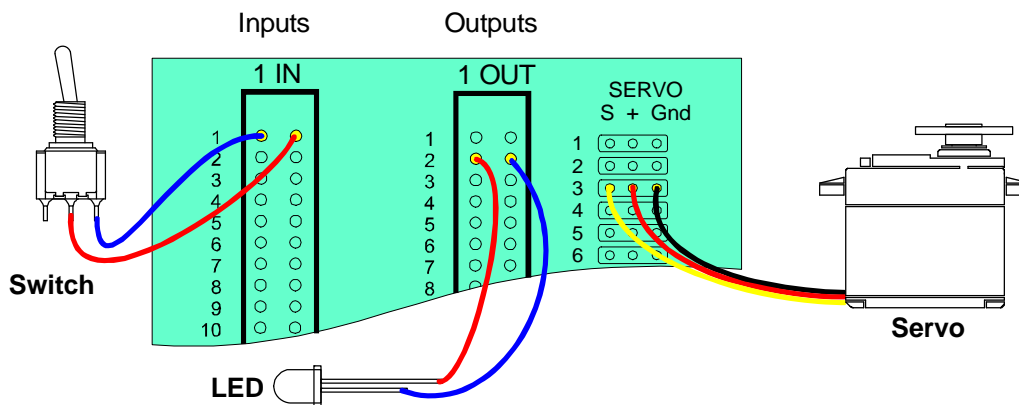

16. Schematics

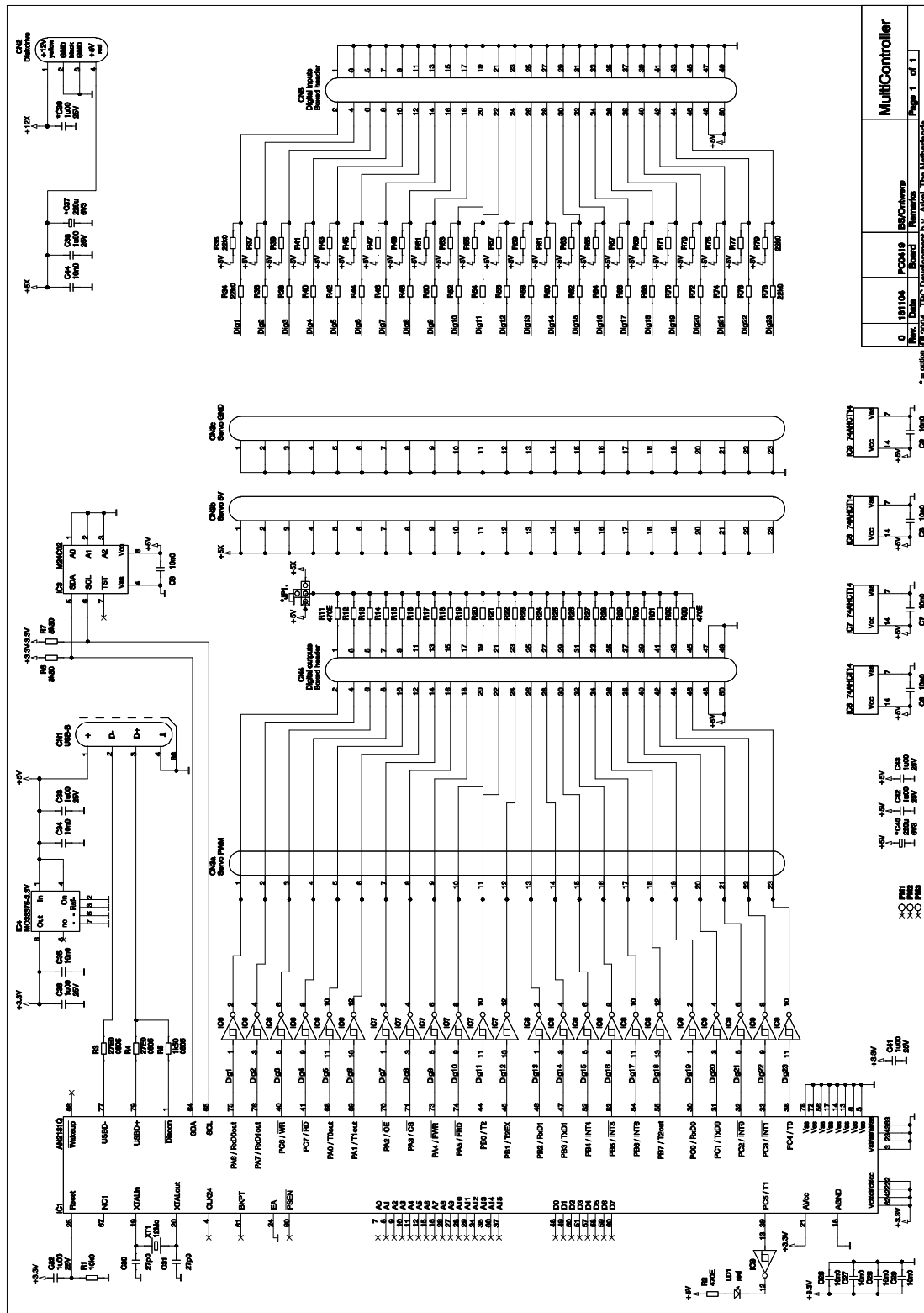

0	191104	PC019	ESControl	MultiController
Rev. 1.00 Board				
© 2004 TRC Development S.A. All rights reserved				

Page 1 of 1

The schematics are supplied only to support you when connecting LED's, switches or servos to the I/O lines. The schematics are copyrighted and confidential.

17. Multi Controller Connector Table

Input Connector

Gnd	1	2	Input 1
Gnd	3	4	Input 2
Gnd	5	6	Input 3
Gnd	7	8	Input 4
Gnd	9	10	Input 5
Gnd	11	12	Input 6
Gnd	13	14	Input 7
Gnd	15	16	Input 8
Gnd	17	18	Input 9
Gnd	19	20	Input 10
Gnd	21	22	Input 11
Gnd	23	24	Input 12
Gnd	25	26	Input 13
Gnd	27	28	Input 14
Gnd	29	30	Input 15
Gnd	31	32	Input 16
Gnd	33	34	Input 17
Gnd	35	36	Input 18
Gnd	37	38	Input 19
Gnd	39	40	Input 20
Gnd	41	42	Input 21
Gnd	43	44	Input 22
Gnd	45	46	Input 23
Gnd	47	48	+5v. (USB)
Gnd	49	50	+5v. (USB)

Output Connector

+5v	1	2	Output 1
+5v	3	4	Output 2
+5v	5	6	Output 3
+5v	7	8	Output 4
+5v	9	10	Output 5
+5v	11	12	Output 6
+5v	13	14	Output 7
+5v	15	16	Output 8
+5v	17	18	Output 9
+5v	19	20	Output 10
+5v	21	22	Output 11
+5v	23	24	Output 12
+5v	25	26	Output 13
+5v	27	28	Output 14
+5v	29	30	Output 15
+5v	31	32	Output 16
+5v	33	34	Output 17
+5v	35	36	Output 18
+5v	37	38	Output 19
+5v	39	40	Output 20
+5v	41	42	Output 21
+5v	43	44	Output 22
+5v	45	46	Output 23
Gnd	47	48	+5v. (USB)
Gnd	49	50	+5v. (USB)

Servo Connector

1	Signal	+5v. Ext	Gnd
2	Signal	+5v. Ext	Gnd
3	Signal	+5v. Ext	Gnd
4	Signal	+5v. Ext	Gnd
5	Signal	+5v. Ext	Gnd
6	Signal	+5v. Ext	Gnd
7	Signal	+5v. Ext	Gnd
8	Signal	+5v. Ext	Gnd
9	Signal	+5v. Ext	Gnd
10	Signal	+5v. Ext	Gnd
11	Signal	+5v. Ext	Gnd
12	Signal	+5v. Ext	Gnd
13	Signal	+5v. Ext	Gnd
14	Signal	+5v. Ext	Gnd
15	Signal	+5v. Ext	Gnd
16	Signal	+5v. Ext	Gnd
17	Signal	+5v. Ext	Gnd
18	Signal	+5v. Ext	Gnd
19	Signal	+5v. Ext	Gnd
20	Signal	+5v. Ext	Gnd
21	Signal	+5v. Ext	Gnd
22	Signal	+5v. Ext	Gnd
23	Signal	+5v. Ext	Gnd

Servo wiring:

Yellow = signal Red = +5V power Black = Ground

Note on Servo outputs:

The servo outputs are driven directly by a 74AHCT14 inverter/driver that can deliver a maximum of 20mA per output.

18. Available expansion boards for the Multi Controller

- Presently no expansion boards are available.

19. Additional important information

Note on Inputs:

All inputs on the Multi Controller board have a pull-up resistor toward the +5v of 22kOhm and a series resistor of 22kOhm.

Note on Outputs:

Depending on the position of the jumper, the Outputs are connected to the +5V from the USB cable or the +5V from a PC power supply via a 470 Ohm resistor, and can drive an LED directly without any additional LED series resistor. A maximum of 20mA can be drawn from each output.

Important notes on connecting to the I/O lines:

Do not draw more current from the outputs than 20mA each. Eventual damages caused by drawing more current than described here are not covered by warranty.

Although the SimKits support group will answer any questions they can, they cannot teach you electronics nor how to read electronic schematics. In these instances, we strongly advise you to seek the support of a friend who has a knowledge of electronics.

Electronics are easily damaged by static electricity, and such damage is not covered by warranty. Static electricity can occur at any time, but is more common under dry or cold conditions (or by shuffling your feet across a carpeted floor). If you have a build-up of static electricity on your person, you can easily damage a controller board by just touching it. It is therefore strongly advised before touching any electronics that you first discharge yourself by touching a water pipe or any other “grounded” material, or by using a static discharging wrist strap (available at most electronics suppliers). When discharging yourself, never touch any electric apparatus or your PC at the same time! TRC Development cannot be held responsible for any personal damages or damages to products due to improper handling.

Support questions can be directed to: support@simkits.com

The Multi Controller and its software is a product of:

TRC Development b.v.

Stationsweg 39

4241 XH ARKEL

THE NETHERLANDS

Phone +31 183 562 522

Fax +31 183 564 268

www.therealcockpit.com

www.simkits.com