



724 Robbins Road
Grand Haven, Michigan 49417
616-842-7110 Phone 800-937-3253
616-842-0859 Fax 800-846-3253
Web: www.dakecorp.com
E-mail : customerservice@dakecorp.com
technicalsupport@dakecorp.com

Dura Press Models **FORCE 10 & FORCE 20** Use and Maintenance Manual Hydraulic Press-Manual Pump



Model No: _____

Serial No: _____

Section I

INTRODUCTION

1. This manual has been created by DAKE to give the Customer all the necessary information for regular use and correct maintenance of the hydraulic presses in the **DURA PRESS** series. It contains the use and maintenance instructions as well as the safety and calibrating instructions requiring your direct action.
2. It is advised to keep this publication in a good condition and somewhere easily accessible to enable rapid reference in case of need or work.
3. Starting checks and maintenance must be carried out assuring the safety of the operators; precautions are highlighted by the → symbol.
4. Periodical and punctual written notes on what has been carried out in the maintenance phase indicates meticulousness, but above all it becomes a clear diary of what has been done and what will have to be done at the next maintenance deadline.
5. For further information, please do not hesitate to call our Dake Technical Service department at 1-800-846-3253, remembering to give the model name and serial number of your press for faster response.
6. It is strictly forbidden to modify or tamper with the machine.
7. Removal, modification or tampering with the guards and safety devices of the press will automatically forfeit warranty and relieve the manufacturer of all liability for any damage to things and/or persons.
8. **THE PRESS IS DESIGNED EXCLUSIVELY TO BE USED BY JUST ONE OPERATOR.**
9. It is advised to read the next section carefully: List of safety checks.

Section II

LIST OF SAFETY CHECKS

ALWAYS ACT WITH
CAUTION
ATTENTION
PRECAUTION

Read the rest of this section very carefully before proceeding to read the following sections.

CAUTION general

When working always pay attention and be alert. Be careful. Be aware of possible hazards.

CAUTION regulations

Observe the law and regulations of the premises regarding you and your machine.

CAUTION clothing

Injury may occur if you do not wear suitable clothing. Loose clothing may get caught up in the machinery. Wear protective clothing suitable for the work. Examples: rigid helmet, safety shoes, safety earmuffs, close-fitting overalls, industrial gloves, etc. Keep cuffs buttoned. Do not wear a tie or scarf, or long hair.

ATTENTION tools

Always check that your tools are in good condition and that the tools are suitable for the work to make (ex. don't use the pliers as hammers etc.)

ATTENTION repairs

Don't make repairs or any other service that you are not familiar with.

ATTENTION tampering

It is severely forbidden to modify or to tamper with press parts that can alter the standard working.

CAUTION hydraulic hoses

Hydraulic hoses may be the cause of accidents. Regularly check such hoses looking for:

- Damaged fittings
- Outer coverings worn by rubber
- Swollen outer coverings
- Bent or crushed hoses
- And anything else that may be a hazard.

CAUTION pressure pipes

The flexible or metal pipes of a system may hold fluids under pressure even with the system switched off. Before dismantling them, check on the diagram whether the section could be under pressure. In any case, loosen the fittings slowly.

CAUTION hydraulic oil

Very fine jets of high-pressure hydraulic oil can penetrate the skin: do not use your fingers to detect any leaks of hydraulic oil, neither put your face close to them, but use a piece of cardboard to check for any leaks on them.

If hydraulic oil penetrates into your skin, get treatment from a doctor immediately.

CAUTION o-rings and gaskets

Gaskets and o-rings fitted incorrectly, damaged or worn may cause leaks and accidents. Do not use thinners, solvents or acids close to o-rings and gaskets.

CAUTION operator

For no reason whatsoever must the operator have their hands in the area of the ram during the pressing operation, on the equipment used.

According to new legislation, the employer will have to check that the operator has understood these notices.

SAFEGUARDING THE POINT OF OPERATION

ANSI B11.2 – Hydraulic Power Presses Safety Requirements for Construction, Care and Use

It is important that Dake press users have a clear understanding of their responsibility involving the care and use of their Dake hydraulic press, including point-of-operation safe guards. Dake strongly recommends that Dake press users obtain a copy of the current American National Standard Institute (ANSI) B11.2 standard, for a more complete understanding of their responsibilities.

ANSI B11.2 states the following, relative to point of operation safeguarding:

“Normally, only the employer (press user) can determine the requirements of the press productions system components, including the dies and methods for feeding. There fore, the employer is ultimately responsible to designate and provide the point-of-operation safeguarding system”.

The standard also discusses additional responsibilities of the employer. Some of the key responsibilities are:

- The employer is responsible for the safety, use and care of the hydraulic power press production system.
- The employer is responsible to consider the sources of hazards for all tasks to be implemented on the hydraulic power press production system.
- The employer is required to eliminate or control identified hazards in the scope of their work activity.
- The employer is responsible for the training of personnel, caring for, inspecting, maintaining and operating hydraulic press production systems to ensure their competence.
- The employer is responsible to provide and ensure that point-of-operation safeguarding is used, checked, maintained and where applicable, adjusted on ever production operation performed on a press production system.

A complete and current copy of the ANSI B11.2 standard can be obtained by contacting the following:

American National Standards Institute
1430 Broadway
New York, NY 10018

AMT – The Association for Manufacturing Technology
7901 Westpark Drive
Mclean, VA 22102

Section III

TABLE OF CONTENTS

SECTION I	INTRODUCTION
SECTION II	LIST OF SAFETY CHECKS
SECTION III	TABLE OF CONTENTS
SECTION 1.0	GENERAL SAFETY INSTRUCTIONS
1.1	General instructions and definitions
1.2	Description
1.3	Use
1.4	Press identification
1.5	Safety labels
1.6	General safety instructions
SECTION 2.0	TECHNICAL DATA SHEET
2.1	Cylinder and spare parts section
2.2	Manual pump and spare parts section
SECTION 3.0	UNPACKING
3.1	Disposing of the packing
SECTION 4.0	HANDLING, TRANSPORTING AND POSITIONING
4.1	Notices for handling and transporting
4.2	Positioning the press
SECTION 5.0	COMMISSIONING AND START-UP
5.1	Filling the press with oil
5.2	Starting the machine
5.3	Discharging the air
5.4	Maximum pressure adjustment
SECTION 6.0	SAFETY INSTRUCTIONS
SECTION 7.0	OPERATION
7.1	Controls
7.2	Mobile table height adjustment
SECTION 8.0	MAINTENANCE
SECTION 9.0	MALFUNCTIONING, CAUSES AND REMEDIES
9.1	Cylinder malfunctioning
SECTION 10.0	PUTTING OUT OF SERVICE
SECTION 11.0	DEMOLITION AND DIVISION OF MATERIALS

Section 1.0

1.1 GENERAL INSTRUCTIONS AND DEFINITIONS

This handbook is an integral part of the product; IT MUST be carefully conserved for future reference.

→ FOR ANY REQUEST FOR CLARIFICATION, ASK YOUR EMPLOYER OR THE DAKE TECHNICAL SERVICE, AVOIDING ANY PERSONAL INITIATIVE THAT COULD CAUSE VERY SERIOUS OR FATAL ACCIDENTS.

→ Before using the machine, read the warranty carefully.

→ DEFINITIONS:

- In this manual “**right-hand side**”, “**left-hand side**”, “**forwards**”, “**backwards**”, “**top**” and “**bottom**” refer to the operator situated in front of the press with the power unit to his right.
- In this manual, the **units of measurement** are expressed in the international system SI (e.g. liquid capacity is expressed in liters).

1.2 DESCRIPTION

The machine described in this manual denominated HYDRAULIC PRESS Model Dura Press has been specifically designed for use in operations where it is necessary to use a force of compression that can be moved into different positions even on the same part:

1. The PRESS BODY, made of high tensile carbon steel and thanks to its monolithic structure, has considerable bending strength.
2. The HAND PUMP, placed on the right of the press allows with facility to reach the work pressure.
3. The HYDRAULIC CYLINDER specially designed for the specific requirements of use of the press. In addition to the special care for the internal surfaces and of the rod, special low-friction gaskets have been used in it to optimize the operations where special precision in the pressing action is required.

1.3 USE

The DURA PRESS/FORCE series press is mainly designed for operations of straightening out sheet metal, profiles, and metal structures, in addition it can be used to insert inserts (e.g. bushes, bearings, bushings, etc.), to remove inserts, calking and all the operations where bending or cutting metal materials are not carried out.

Other uses are not allowed unless the manufacturer expressly authorizes them.

The substance of the above mentioned operation will always be subordinate to the maximum working capacity of the press.

THIS MACHINE IS DESTINED ONLY FOR THE USE IT HAS BEEN DESIGNED FOR, ANY OTHER USE IS TO BE CONSIDERED IMPROPER AND THEREFORE THE MANUFACTURER CANNOT BE HELD LIABLE FOR ANY DAMAGE CAUSED BY ANY IMPROPER USE OR USE NOT EXPRESSLY MENTIONED IN THIS USER'S MANUAL.

1.4 PRESS IDENTIFICATION

The press is fitted with a rating plate fixed in a visible manner on the **rear** as shown in Fig. 01 below. Dake part number and serial number on front name plate shown in Fig. 03

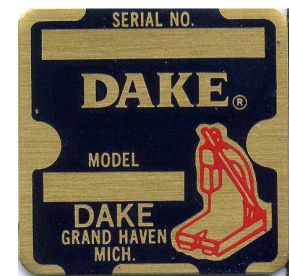
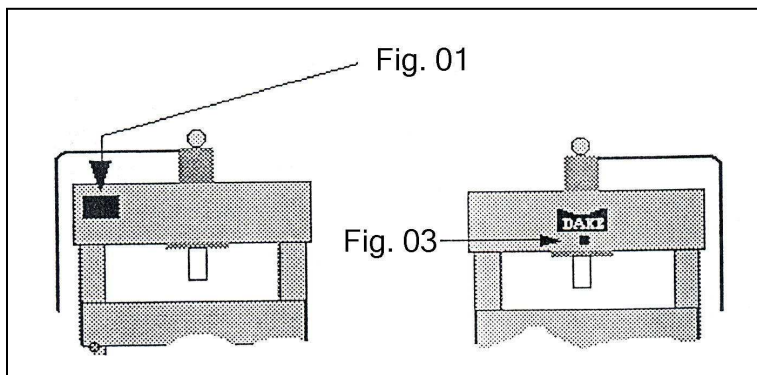

Fig. 03A
Part No. 607

The rating plate (Fig. 02/03A) shows the identification data:

- Press model
- Max. tonnage
- Max. pressure
- Press serial number/ Year of Manufacture
- Dake part number (Tag 03)
- Serial number (Tag 03)

MODEL	PSS
TON MAX	20
PRESSURE MAX	200
SERIAL NO.DAKE	023.98

Fig. 02

FOR EVERY COMMUNICATION, REQUEST FOR SERVICE OR SPARE PARTS, IT IS ALWAYS ESSENTIAL TO QUOTE ALL THE DATA GIVEN ON THE RATING PLATE.

1.5 SAFETY LABELS

The labels on the machine highlight particular risks or provide necessary instructions for particular operations to be carried out in safety.

Here we reproduce the labels affixed to the press and indicate their location. The operator will have to check that these labels are present on the machine and fixed in a stable manner. In the event of any of them missing or having deteriorated it will be necessary to immediately notify the person in charge of safety and to forward a request to the manufacturer.

WARNING LABELS



To the left is the safety Alert symbol. When you see these safety alert symbols on your press, be alert to the potential for personal injury.

Follow recommended precautions and safe operating practices.

Carefully read all safety messages in these instructions and on your press safety signs. Keep safety labels in good condition. Replace missing or damaged safety labels. **This machine is intended to be operated by one person.** This person should be conscious of the press ram movement not only for himself but also for persons in the immediate area of the machine.



Label 300168

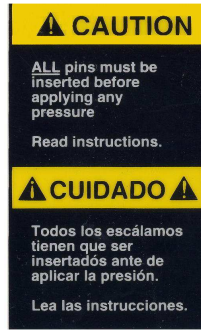

Label 84487

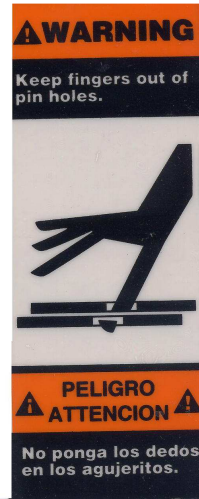

Label 84399

Label Placement View

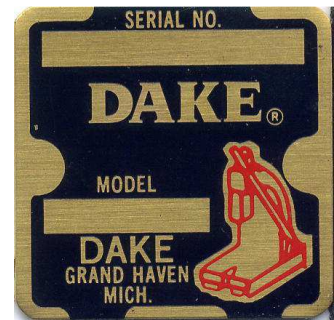
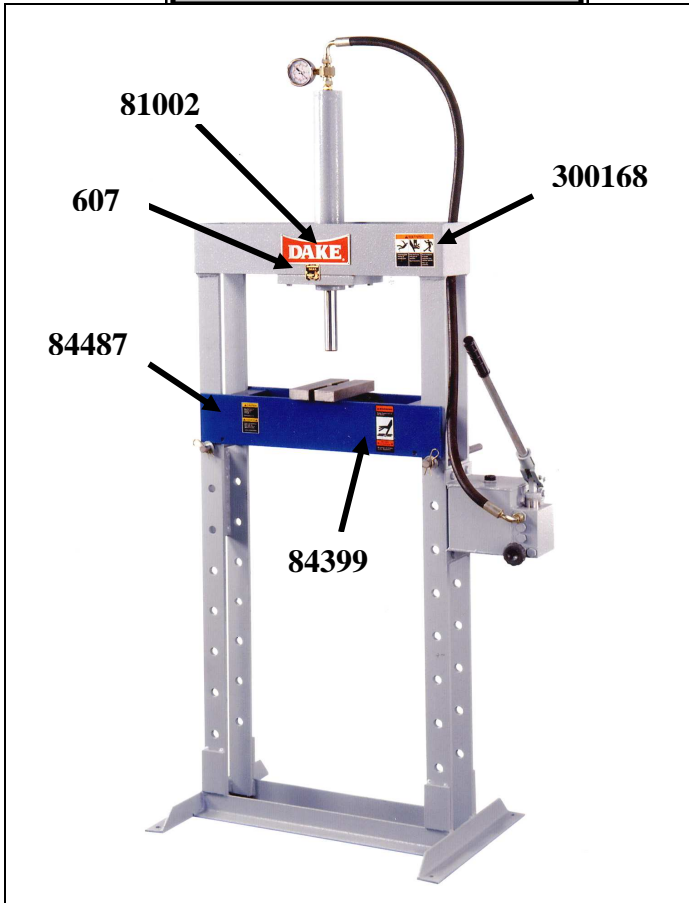

Label 607

1.6 GENERAL SAFETY INSTRUCTIONS

- Use of the press is allowed exclusively for trained and authorized personnel.
- When you leave the machine, even if only for a moment, make sure it is not in the pressing phase, dangerous for you and for others.
- In the event of confusion or uncertainty in the manner of operation to be made, refer to the user's manual or call qualified personnel to resolve your doubts.
- Operate the manual pump only from the working position that is in front of the hydraulic power unit.
- It is forbidden to use equipment or carry out operations that may have even the slightest chance of projecting splinters or parts of equipment.

Section 2.0

2.0 TECHNICAL DATA SHEET

Below we give a table summarizing the technical-dimensional particulars of the DURA series Presses.

Model Dura Press	Ton Max.	Width between Uprights	Width between Table Channels	Max. Ram Travel	Max. Ram to Table	Base (w x d)	Height	Weight lbs
Force 10	10	20"	4"	6"	36"	31 x 19"	71"	350
Force 20	20	20"	4"	6"	36"	31 x 19"	71"	485

Model Dura Press	Bore	Thread Hole size
Force 10	60 mm	12 mm
Force 20	80 mm	12 mm

MAXIMUM OPERATING PRESSURE FOR ALL MODELS 350 bars.

2.1 CYLINDER AND SPARE PARTS SECTION

Model Force 10M & Force 20M Breakdown

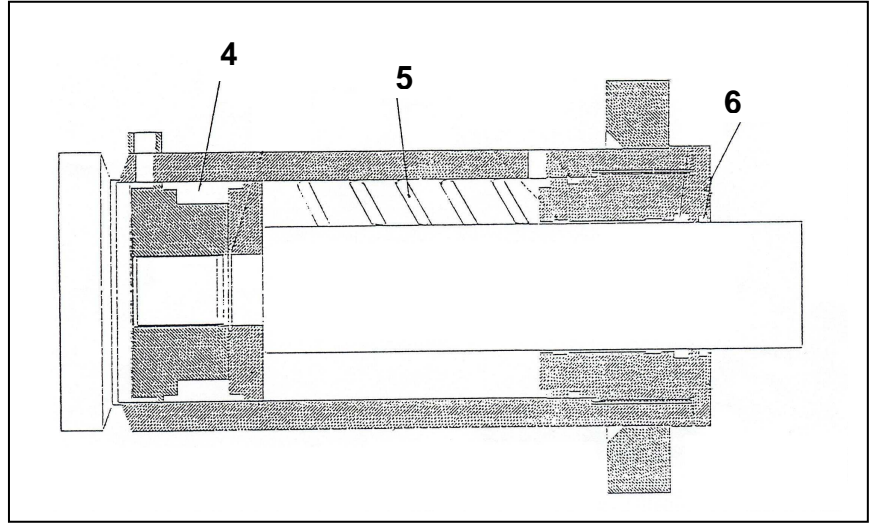
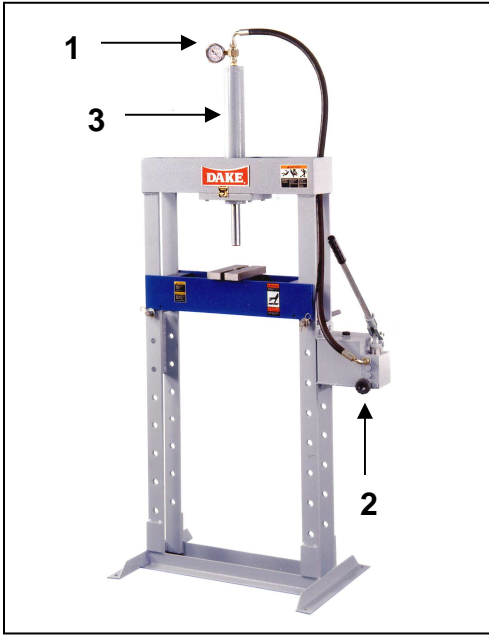

Item No	Description	Part Number	
		Force 10M	Force 20M
1	Gauge Bar	300357	300358
	Gauge in tons	301723	301722
2	Hand Pump - Complete	300366	301485
3	Hydraulic Cylinder Complete	300652	301343
4	Piston Gasket	300796	301558
5	Spring	300797	301560
6	Head Scraper	300798	301561
	Fitting for gauge	301888	301888

Model Force 10M & Force 20M Breakdown Hand Pump Assembly

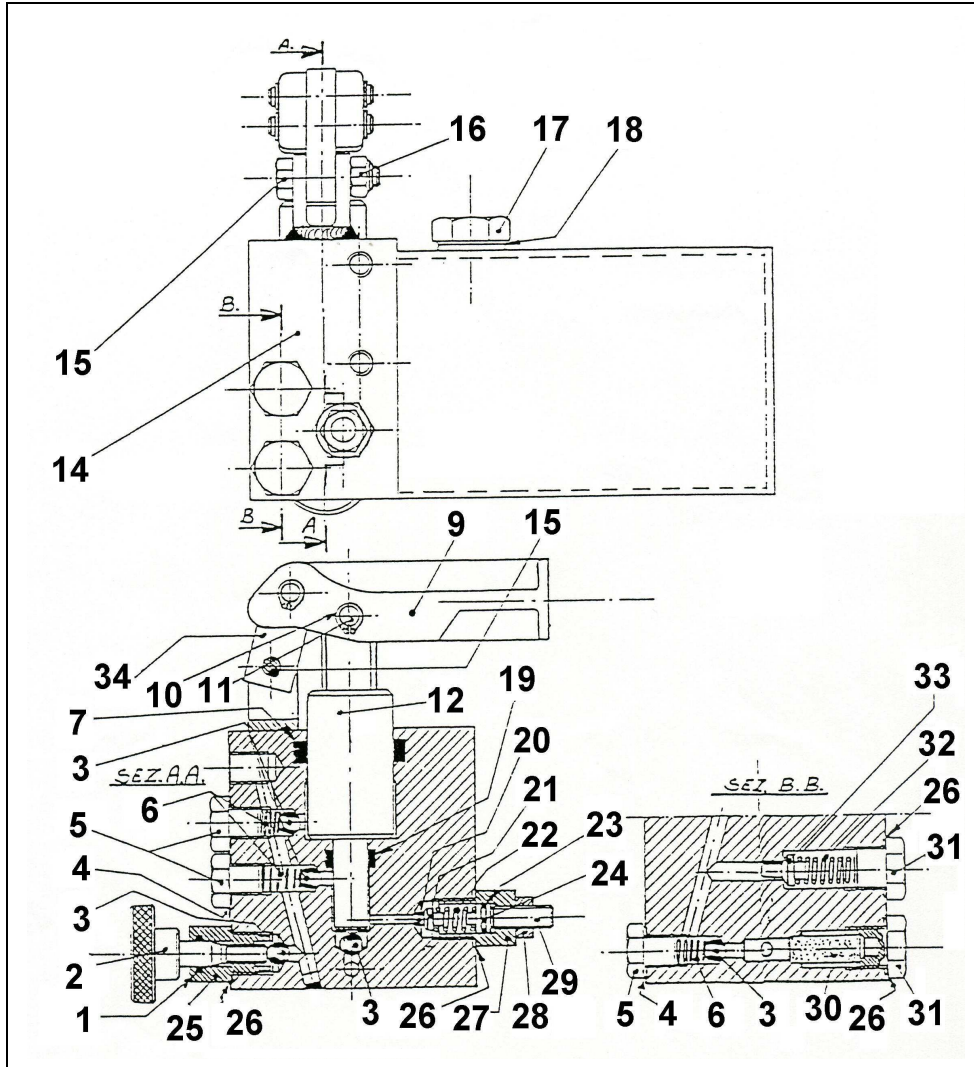

Item No	Description	Part Number	
		Force 10M	Force 20M
12	Piston Pump	302367	302367
2	Handwheel	302368	302368
20:29	Valve	302369	302369
31-32-33	Valve	302370	302370
30	Filter	N/A	N/A
34	Rod assembly	302373	302373
6	Spring	302372	302346
5	Cap	302371	302371
25	Tap Screw	N/A	N/A
Complete Pump		300366	301485
Gasket Repair Kit		301327	301542
Linkage Assembly (Item 9,10,11,15,16,34)		301575	301574
Relief Valve (Item 1,2,3,4,5)		301576	--
Relief Valve 4NV		--	301573
* If n/a is shown must replace entire pump			

3.0 UNPACKING

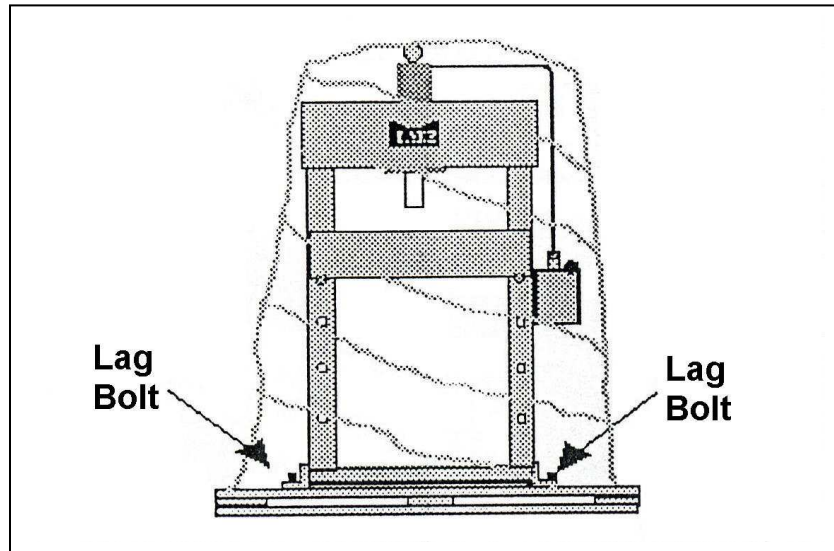

If the machine is supplied wrapped in plastic sheet, any accessories, spare parts and expendables are packed in cardboard boxes and positioned on top of the worktable.

To remove the packing, cut the plastic wrap, taking care not to damage the machine or cardboard box.

Remove any accessories from on top of the worktable, check the contents correspond to the order and to the accompanying documentation.

After removing the plastic, unbolt the lag bolts from the skid.

For handling and transport, please refer to **Section 4.0**.

3.1 DISPOSING OF THE PACKING

The packing will have to be disposed of by the purchaser in compliance with their local regulations.

The elements comprising the packing (e.g. plastic bags, polystyrene, nails, nylon, etc.) **MUST NOT** be left within the reach of children as they are a source of danger for them.

CLAIMS SHALL NOT BE ACCEPTED IN THE EVENT OF THE GOODS NOT BEING IN CONFORMITY WITH THE ORDER OR WITH THE ACCOMPANYING DOCUMENTS IF THEY ARE NOT NOTIFIED WITHIN FIVE DAYS OF THE DATE OF RECEIVING THE GOODS.

Section 4.0

4.0 HANDLING, TRANSPORT AND POSITIONING

For handling the packed machine, as described above (see section 3.0), it is necessary to use special lifting equipment whose maximum lifting capacity must be no lower than the total weight of the press.

THE TOTAL WEIGHT OF THE PRESS PLUS PACKING IS SHOWN ON THE ADHESIVE TABS PLACED ON THE PACKING AND ON THE ACCOMPANYING DOCUMENTS.

For loading and unloading the machine, lifting straps are to be used positioned as shown in Fig. 04.

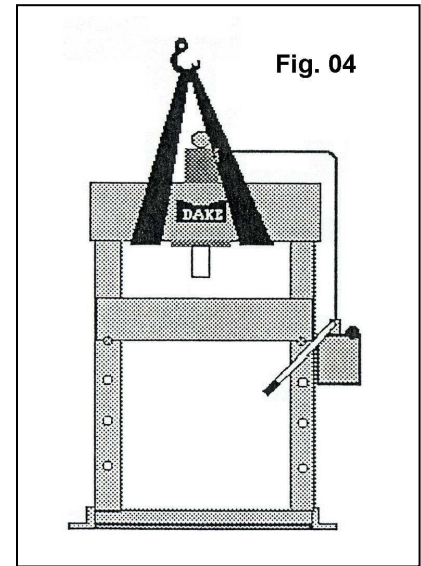

4.1 NOTICES FOR HANDLING AND TRANSPORT

Loading and unloading will have to be done with lifting straps in conformity with and according to the instructions of the above paragraph, **in addition check:**

→ Check that the straps are made in conformity with safety regulations and they have attached the relative plates certifying they are in conformity with the standards.

→ CHECK THAT THE MAXIMUM CAPACITY OF EACH STRAP IS GREATER THAN THE TOTAL WEIGHT OF THE PRESS.

→ Check that the straps are in a good state of repair.

→ It is forbidden for things and/or persons to stand close to the machine, the unloading or loading area, and the means of transport during the loading and unloading phases.

→ Do not make any sudden movements with the lifting equipment while lifting or lowering the load.

→ Pay the utmost attention during all handling operations so that the press and in particular the hydraulic power unit does not get damaged.

→ Observe the in-house provisions concerning lifting and handling.

→ IT IS FORBIDDEN TO APPROACH OR PASS UNDER HANGING LOADS.

THE MANUFACTURER DECLINES ALL LIABILITY FOR ANY DAMAGE CAUSED BY ANY ACTION DURING THE PHASE OF UNLOADING AND LOADING THE PRESS.

4.2 POSITIONING THE PRESS

Simple precautions are necessary for correctly positioning the press. Always consider the safety aspect not only in relation to the work carried out with the press, but also to the dangers originated by the other machines in the workplace. Before positioning, check that

- The floor is suitable for positioning the press that is it has no holes or subsiding portions, and that its capacity is sufficient to sustain the weight of the press plus the weight of the accessory parts and of any piece to be processed if of large dimensions, considering an appropriate coefficient of safety.
- **Do not do the positioning on unstable or non-compact surfaces (e.g. on gravel or grit, beaten earth, sand, etc.).**
- **PAY THE UTMOST ATTENTION TO OVERHEAD ELECTRICITY LINES.**
- **Check beforehand the position of any overhead electricity lines and mark them with special warning cards.**
- Always consider a suitable distance from the sliding paths for the means of transport, elevators, transpallets, etc., sudden and unexpected sources of danger.
- Check that the position identified is always served by adequate lifting systems.
- Pay the utmost attention to handling the lifting systems (e.g. overhead traveling cranes, hoists, transpallets, fork-lift trucks, cranes, jib cranes, etc.)

After identifying the most suitable place for positioning, follow the instructions for handling of **Section 5.0**, mark a square on the floor with YELLOW paint (highly resistant to abrasion) around the perimeter of the press as shown by the diagram in Fig. 06.

The area highlighted in this way will indicate the area of caution for the lifting equipment and the personnel nearby.

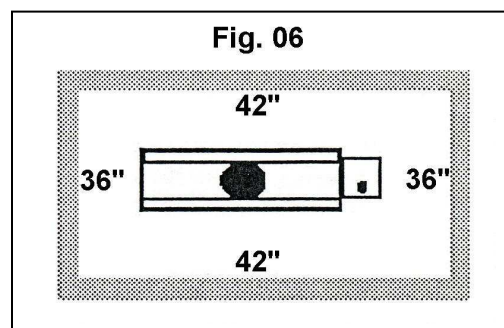

Section 5.0

5.0 COMMISSIONING AND STARTING

This section describes the operations to be followed on commissioning along with some advice for starting the machine for the first time.

5.1 FILLING THE PRESS WITH OIL

To fill the press, use exclusively the oils indicated in the table or ones of equivalent reliability. The choice must be made considering the environmental conditions and the operating features of the press.

Manufacturer	A	B	C
Mobil	DTE 24	DTE 25	DTE 26
DIN 51524	H-LP 32	H-LP 46	H-LP 68
Castrol	Hysoin AWS 32	Hysoin AWS 46	Hysoin AWS 68
ESSO	Nuto H 32	Nuto H 46	Nuto H 68
Shell	Tellus 32	Tellus 46	Tellus 68
Chevron	EP Hydr. Oil 32	EP Hydr. Oil 46	EP Hydr. Oil 68

Choose the type of oil (column A, B, C) on the basis of the average working temperature, for temperate climates the reference column is "B". For operating conditions in colder climates use column "A", for warmer climates select column "C".

5.2 FIRST STARTING

The press was shipped without oil.

After you have filled up the tank you have to stroke the hand pump until the ram is fully extended out of the cylinder, release the wheel under the pump to return the ram. You have to verify the oil level in the tank and if needed refill the tank. You have to repeat the above-mentioned operation sometimes to bleed the air from the system. See **Air Discharge Section 5.3**.

The level of oil in the tank may fall on starting, because of:

- **absorption of volume by the cylinder**
- **absorption of volume by the pumping unit**
- **discharge of air bubbles remaining in the piping**

It is necessary to top off the level of oil bringing it up to the correct height.

5.3 AIR DISCHARGE

After the first start-up, or after maintenance carried out on elements of the system (e.g. cylinders, filters, pipes, changing oil) a considerable quantity of air may be present in the circuit.

Irregular operation, noise, and/or uneven cylinder movement highlight the presence of air.

It is necessary to discharge the air as follows:

- Pump ram down to the maximum stroke.
- Loosen the upper nipple of the press cylinder and wrap it in a cloth to avoid oil splashes.
- Stroke the hand pump to remove the air.
- Verify that all the air has been bled out of the system when only oil is expelled from the fitting.
- Tighten the nipple.

This operation must be continued until oil is completely free of air bubbles or froth.
After discharging the air, it is necessary to top off the oil level in the unit.

5.4 MAXIMUM PRESSURE ADJUSTMENT

The maximum work pressure of the press is adjusted by pressure regulator valve suitably set and sealed with lead.

DAKE DECLINES ALL LIABILITY FOR DAMAGE TO THINGS AND/OR PERSONS CAUSED BY TAMPERING WITH THE PRESSURE CONTROL VALVE FITTED ON THE UNIT.

Section 6.0

6.0 SAFETY INSTRUCTIONS

THE MANUFACTURER DECLINES ALL LIABILITY FOR DAMAGE TO THINGS OR PERSONS CAUSED BY NON-OBSERVANCE OF THE SAFETY INSTRUCTIONS GIVEN IN THIS MANUAL WHICH SUPPLEMENT THE CURRENT LEGAL REGULATIONS IN WORKPLACES.

IT IS EXTREMELY IMPORTANT FOR THE OPERATOR TO UNDERSTAND ALL THE SAFETY INSTRUCTIONS LISTED BELOW IN ORDER TO PREVENT DAMAGE TO THEMSELVES, TO THINGS OR TO OTHERS.

→ A machine not subject to regular maintenance is a danger for the operator and for the persons working nearby. To ensure safe and efficient operation of the machine, check that the maintenance schedule is regularly observed.

→ It is strictly forbidden to tamper with, modify, or elaborate parts of the machine that alter its regular operation.

→ The press is designed exclusively for use by a single operator.

→ **Use of the press is reserved exclusively for authorized and qualified personnel informed about the risks deriving from its use.**

→ Before operating the machine, the operator will check that there is no equipment or persons in the immediate vicinity of the machine whose presence may be dangerous for themselves and for others.

→ **All work requiring the piece to be pressed to be supported by the operator is forbidden.**

→ It is necessary to arrange suitable supporting and positioning equipment for the pieces to be pressed.

→ **It is strictly forbidden to press, cut, draw, and do anything else with pieces whose dimensions or physical nature may explode or product splinters.**

→ In the event of there being the slightest possibility of the pressed piece exploding the user is obliged to arrange a protective barrier of adequate dimensions and substance (e.g. polycarbonate) all around the press to protect the personnel present, and to position an additional partition between the control area and the work area to protect the operator.

Section 7.0

7.0 OPERATION

Before starting any operations, make sure there are no other persons in the immediate vicinity of the machine.

IT IS STRICTLY FORBIDDEN TO PASS UNDER THE WORK TABLE.

7.1 CONTROLS

To make the press work you have to stroke the pump control lever.

The feed speed of the cylinder and the pressure will depend on the driving speed of the pump control lever. The pressure starts to rise when the cylinder shaft is in contact with the piece of press, continuing with the pump action the pressure rises until to have the necessary valve to make the operation.

For the ram to retract, loosen the valve placed under the pump control lever. The cylinder is equipped with a spring for the ram return.

7.2 HEIGHT ADJUSTMENT OF THE MOVABLE BASE

To get very good use of the press it is necessary to place the worktable at a correct height depending on the operation to make and on the tooling to use.

1. To the size of the part to be pressed.
2. To any tooling placed on the movable table.
3. With the help of a second worker to lift the movable table.
4. To take away the pins and to place them in the holes of the correct height.
5. To lower slowly the worktable onto the pins.
6. To verify the positioning of the table and of the pins.

If the work position you wish corresponds with the max. width of the work size it is not necessary to place the pins (that will be placed in a dry place) because we have foreseen and prepared stops suitably welded to the stanchions.

Section 8.0

8.0 MAINTENANCE

AUTHORIZED AND TRAINED PERSONNEL MUST CARRY OUT ROUTINE MAINTENANCE OPERATIONS.

ALL MAINTENANCE OR CLEANING OPERATIONS MUST BE DONE WITH THE MASTER SWITCH OFF. (IF EQUIPPED)

SPECIAL MAINTENANCE OPERATIONS (REPAIRS) MUST BE CARRIED OUT BY THE MANUFACTURER'S PERSONNEL ON THE PREMISES OF THE MANUFACTURER OR BY SUITABLY TRAINED AND SPECIALIZED PERSONNEL UPON AUTHORIZATION BY THE MANUFACTURER.

Routine maintenance operations apply to the mechanical part of this appliance, the only special prescriptions concern checking the oil level, the characteristics of the fluid used (and possible replacement in the case of its deterioration).

It is a good rule to take note of maintenance work to help you remember all the work carried out on the unit.

8.1 OIL LEVEL

Check the level of oil every month through the oil fill cap hole on the top of the oil tank. Visual inspection of the oil level should be approximately ½" below the top of the tank.

Any topping off has to be done with the same type of and clean oil used in the filling phase of the system and with the same procedures as regards cleaning the fluid.

It is advised to note the type of oil used on a card affixed onto the unit or on the last few pages of this manual, containing pre-printed tables to be filled in.

If topping off turns out to be too frequent, check for leaks in the system.

8.2 CHANGING AND DISPOSING OF THE OIL

The oil will have to be changed periodically every 2000 operating hours or at least once a year.

Changing the oil, and therefore disposing of it, will have to be done in conformity with the law as hydraulic oil is considered special waste. Call authorized firms for the disposal of special wastes.

DO NOT DISPERSE SPENT OIL INTO THE ENVIRONMENT

Take care while handling oil, excessive or extended contact can cause irritation. In this case, wash the area involved with plenty of water and soap or special detergent.

8.3 CLEANING

CARRY OUT THE CLEANING OPERATIONS EVERY WEEK.

It is a good rule to carry out periodical cleaning of the press in order to eliminate foreign bodies (e.g. dust, extraneous and dirty substances, etc.).

Eliminate all foreign bodies from the piston rod that could damage both the surface of the rod and the cylinder gaskets.

While cleaning, use detergent substances that are not harmful, do not pollute and are in conformity with the law.

While cleaning, prevent shaking with hands, wear protective gloves and use brushes or oilers to lubricate the guides.

Do not use solvents or aggressive acids.

Section 9.0

9.0 MALFUNCTIONING, CAUSES and REMEDIES

9.1 CYLINDER MALFUNCTIONING

CYLINDERS			
MALFUNCTION	ORIGIN	REMEDY	
The cylinder moves irregularly	<ul style="list-style-type: none"> - Air in the pump - Air in the circuit - Damage cylinder gaskets - Damage or worn pump - Sequence valve jammed - Delivery pipe clogged or choked. 	<ul style="list-style-type: none"> - Bleed the air - Bleed the air - Replace the gaskets - Replace the pump - Recondition seq. valve - Check pipes 	* *
Cylinder will not move	<ul style="list-style-type: none"> - Cylinder gaskets completely damaged - Blocked distributor - Damaged pump 	<ul style="list-style-type: none"> - Replace - Recondition distributor - Recondition or replace 	* *
Cylinder leaks oil	<ul style="list-style-type: none"> - Head gasket damaged or worn 	<ul style="list-style-type: none"> - Replace 	
Cylinder will not press	<ul style="list-style-type: none"> - Lack of pressure from pump - Pressure control valve set low 	<ul style="list-style-type: none"> - Recondition pump - Set valve 	*

*** Call Dake Technical Service 1-800-937-3253**

Section 10.0

10.0 PUTTING OUT OF SERVICE

In the case of putting away for a long period it is necessary to empty the unit of oil and protect it suitably so there is no dust, moisture, or other foreign bodies, exposed to the unit that can damage the parts of the unit.

When putting into operation after a period of storage, meticulously follow ALL the indications of Section 5.0.

Section 11.0

11.0 DEMOLITION AND DIVISION OF MATERIALS

If you are not going to use the appliance any more, it is recommended to make it inoperative by removing the oil contained in the tank and eliminating the oil remaining in the cylinder, pipes, pump body and valves.

When going for demolition the press must be treated as special waste, it must therefore be split up into its homogeneous parts, these parts must be separately disposed of in conformity with the laws in force.



724 Robbins Road
Grand Haven, Michigan 49417
616-842-7110 Phone 800-937-3253
616-842-0859 Fax 800-846-3253
Web: www.dakecorp.com
E-mail : customerservice@dakecorp.com
technicalsupport@dakecorp.com

Gauge Conversion 10 ton
Bore 60 mm = 2.362"

10 Ton	302 bar	4565 PSI
5 Ton	151 bar	2282 PSI
4 Ton	121 bar	1825 PSI
3 Ton	90 bar	1369 PSI
2 Ton	60 bar	913 PSI
1 Ton	30 bar	456 PSI

Gauge Conversion 20 ton
Bore 80 mm = 3.149"

20 Ton	340 bar	5136 PSI
15 Ton	255 bar	3852 PSI
10 Ton	170 bar	2568 PSI
5 Ton	85 bar	1284 PSI
4 Ton	68 bar	1027 PSI
3 Ton	51 bar	770 PSI
2 Ton	34 bar	514 PSI
1 Ton	17 bar	257 PSI