

PNEUMATIC RAM

Double column

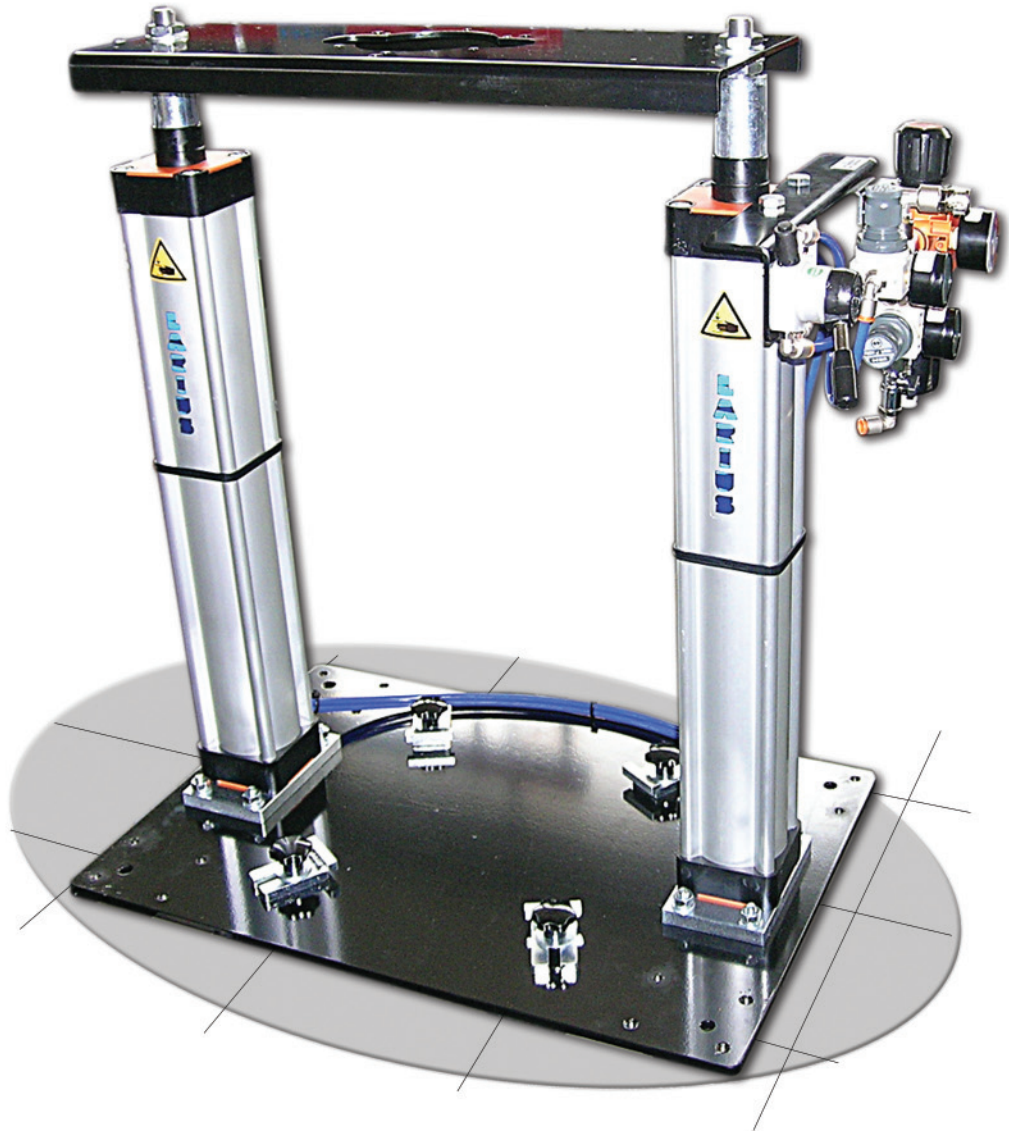

**OPERATING AND
MAINTENANCE INSTRUCTIONS**

LARIUS

PAINTING EQUIPMENT

ENGLISH

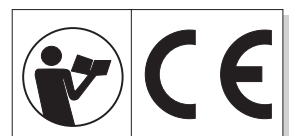

LARIUS

DOUBLE COLUMN PNEUMATIC RAM













WORKING PRINCIPLE	p.1	F WORKING	p.7
WARNINGS	p.2	G REPLACEMENT OF THE DRUM	p.10
A WORKING PRINCIPLE	p.3	H ROUTIN MAINTENANCE.....	p.11
B TECHNICAL DATA.....	p.3	I PROBLEMS AND SOLUTION.....	p.11
C DESCRIPTION OF THE EQUIPMENT.....	p.4	L SPARE PARTS	p.12
D SAFETY RULES.....	p.6	M VERSIONS	p.13
E SETTING-UP.....	p.6		

WE ADVISE THE USE OF THIS EQUIPMENT ONLY BY PROFESSIONAL OPERATORS.
ONLY USE THIS MACHINE FOR USAGE SPECIFICALLY MENTIONED IN THIS MANUAL.

Thank you for choosing a **LARIUS s.r.l.**
As well as the product purchased,
you will receive a range of support services
enabling you to achieve the results desired,
quickly and professionally.

WARNINGS

The table below provides the meaning of the symbols used in this manual in relation to using, earthing, operating, maintaining, and repairing of this equipment.

	<p>Read this operator's manual carefully before using the equipment. An improper use of this machine can cause injuries to people or things. Do not use this machine when under the influence of drugs or alcohol. Do not modify the equipment under any circumstances. Use products and solvents that are compatible with the various parts of the equipment, and read the manufacturer's warnings carefully. See the Technical Details for the equipment given in the Manual. Check the equipment for worn parts once a day. If any worn parts are found, replace them using ONLY original spare parts. Keep children and animals away from work area. Comply with all safety standards.</p>
	<p>It indicates an accident risk or serious damage to equipment if this warning is not followed.</p>
	<p>It indicates a fire or explosion risk if this warning is not followed. Eliminate all ignition sources such as pilot lights, cigarettes, portable electric lamps and plastic drop cloths. Keep work area free of debris. ONLY use this equipment in a well ventilated area. EARTH ALL THE EQUIPMENT LOCATED IN THE WORK AREA. Do not form connections or switch light switches on or off if the air contains inflammable fumes. If electrical shocks or discharges are encountered the operation being carried out using the equipment must be stopped immediately. Keep a fire extinguisher at hand in the immediate vicinity of the work area.</p>
	<p>It indicates wound and finger squashing risk due to movable parts in the equipment. Tenersi lontano dalle parti in movimento. Do not use the equipment without the proper protection. Before any inspection or maintenance of the equipment, carry out the decompression procedure explained in this manual, and prevent any risk of the equipment starting unexpectedly.</p>
	<p>It indicates the danger of carriage unexpected movement on slanting surfaces</p>
	<p>It indicates important recommendations about disposal and recycling process of products in accordance with the environmental regulations.</p>
	<p>Report any danger of electric shock if the warning and presence of live electrical parts has not been indicated. Store in a dry place and do not expose to the rain. Check that the cables are in good condition. Switch off the equipment and discharge any electricity before cleaning or maintaining the equipment.</p>
	<p>Mark any clamps attached to earth cables. Use ONLY 3-wire extension cords and grounded electrical outlets. Before starting work make sure that the electrical system is earthed and that it complies with safety standards.</p>
   	<p>It is obligatory to wear suitable clothing as gloves, goggles and face shield. Wear clothing that complies with the safety standards in force in the country in which the equipment is used. Do not wear bracelets, earrings, rings, chains, or anything else that may hinder the operator's work. Do not wear clothing with wide sleeves, scarves, ties, or any other piece of clothing that could get tangled up in moving parts of the equipment during the work, inspection, or maintenance cycles.</p>

A WORKING PRINCIPLE

This type of pneumatic lifting ram allows to lift transfer and extrusion pumps of **LARIUS GHIBLI** and **VEGA** series. The use of the ram enables to drive the sucking unit of the pump during the product intake phase directly into the 25 litres drums (or similar drums). At the base of the pump sucking unit a shovel plate is mounted to compress the material assuring a constant flow during use. The shovel plate is supplied with a series of gaskets able to protect the product contained in the drum from powder, moisture and

drying process caused by the touch with air. The ram can automatically compensate the shovel plate descent during the use of the product. This system allows a quick replacement of the drum when the product is finished.



B TECHNICAL DATA

PNEUMATIC RAM	
FEED AIR PRESSURE (MAX)	7 bar
FEED AIR INLET	Bayonet
WEIGHT	40 Kg
OVERALL DIMENSION	600X800X900

C DESCRIPTION OF THE EQUIPMENT

English

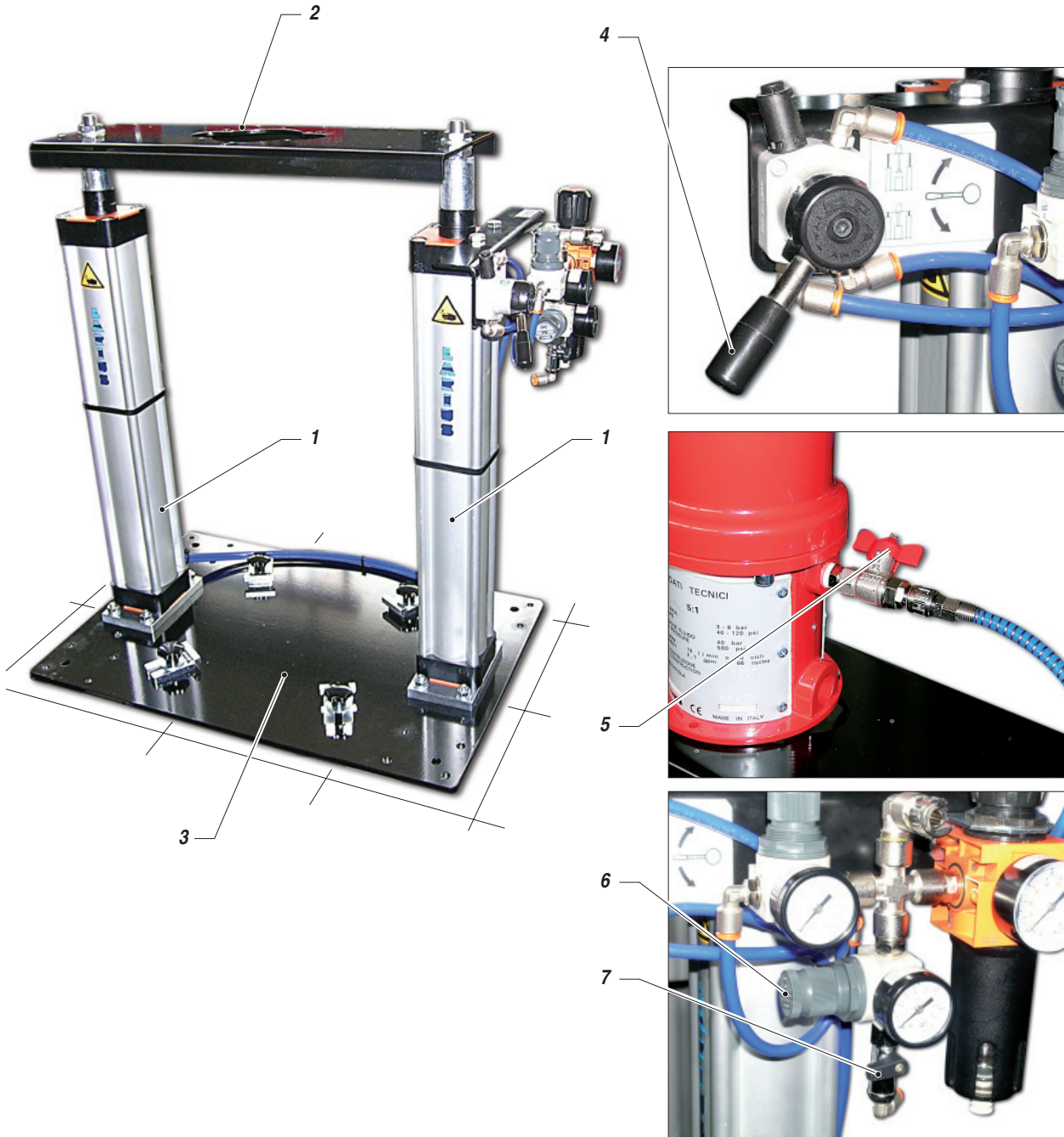

POS.	Description
1	Lifting cylinders
2	Pump face
3	Face for drum product
4	Control lever (up/down)

POS.	Description
5	Pump air valve
6	Shovel plate pressure gauge
7	Shovel plate valve

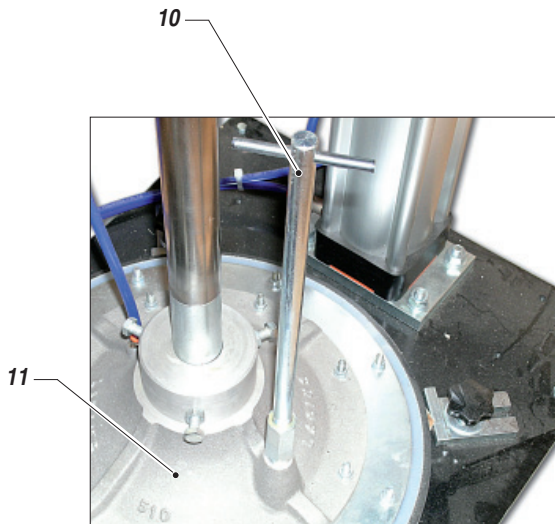
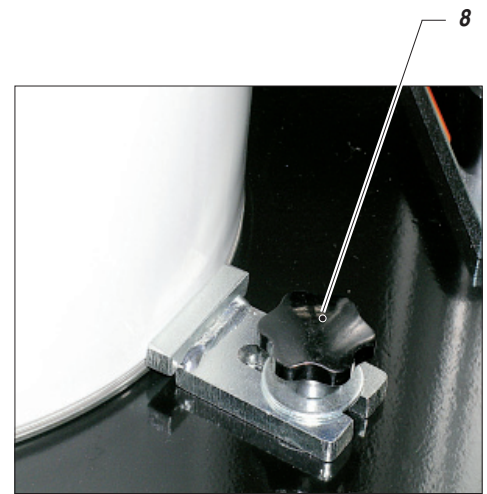
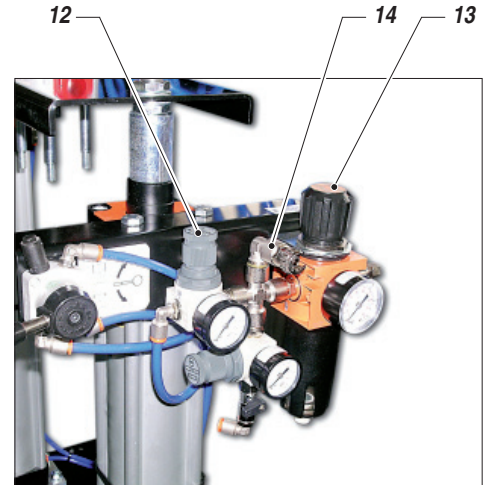
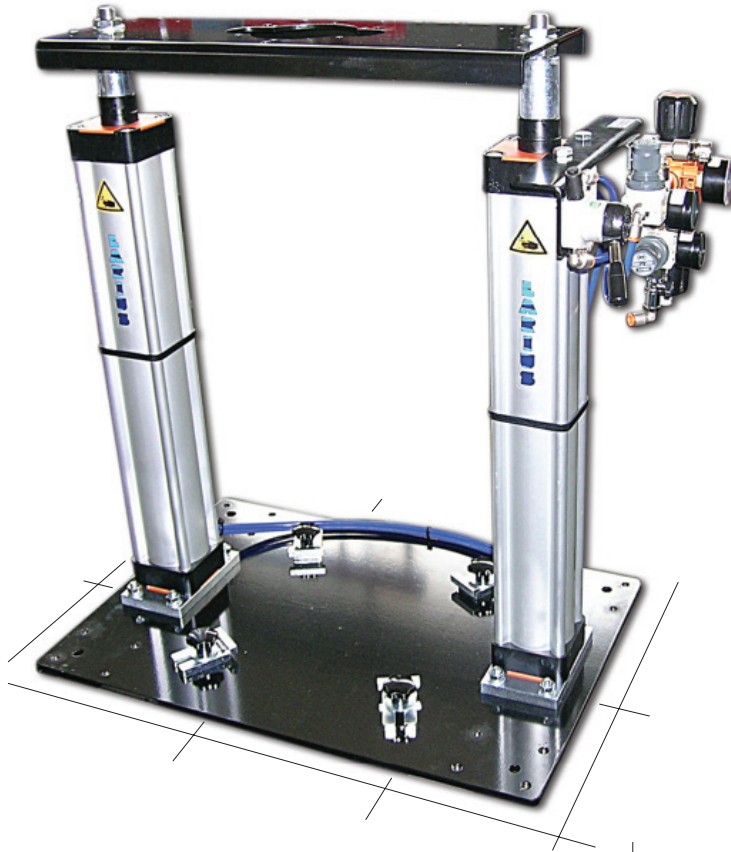

POS.	Description
8	Drum-block
9	Drum product
10	Bleeder valve
11	Shovel plate

POS.	Description
12	Up/down pressure gauge control
13	Pump pressure gauge
14	Main air feeder

D SAFETY RULES



 These instructions refer to the correct use of the pneumatic ram. In addition, read carefully the Instructions contained in the manuals relevant to the different components (pneumatic pump, delivery gun, etc.) which can be used with the ram.

- ALWAYS KEEP CLEAN AND TIDY THE WORK AREA.
- KEEP THOSE WHO ARE NOT RESPONSABLE FOR THE EQUIPMENT OUT OF THE WORK AREA.
- BEFORE USING THE EQUIPMENT, THE OPERATOR MUST BE TRAINED AND INFORMED ABOUT THE POSITION AND WORKING OF ALL THE CONTROLS OF THE EQUIPMENT.
- **NEVER** EXCEED THE MAXIMUM WORKING PRESSURE INDICATED.
- RELEASE THE PRESSURE IN THE CIRCUIT BEFORE PERFORMING ANY CHECK OR PART REPLACEMENT OF THE EQUIPMENT.
- NEVER MODIFY PARTS IN THE EQUIPMENT. CHECK REGULARLY THE COMPONENTS OF THE SYSTEM. REPLACE THE PARTS DAMAGED OR WORN.
- TIGHTEN AND CHECK ALL THE FITTINGS FOR CONNECTION BETWEEN PUMP, FLEXIBLE HOSE AND SPRAY GUN BEFORE USING THE EQUIPMENT.
- DO NOT APPROACH TOO MUCH TO THE RAM DURING ITS ASCENT AND DESCENT OPERATIONS.
- BEFORE ANY MAINTENANCE OPERATIONS DISCONNECT THE ELECTRIC VOLTAGE.

 Never spray over flammable products or solvents in closed places never use the tooling in presence of potentially explosive gas always check the product is compatible with the materials composing the equipment (pump, spray gun, flexible hose and accessories) with which it can come into contact.



 When the unit is in operation do not get too close to the mobile parts, in order to avoid possible injuries at the hands or fingers.

   IF THE PRODUCT TO BE USED IS TOXIC, AVOID INHALATION AND CONTACT BY USING PROTECTION GLOVES, GOGGLES AND PROPER FACE SHIELDS.

E SETTING-UP

The operator will have to arrange an environment suitable to the plant before installing it as indicated here below:

- An area wide enough to allow the drum loading and unloading and routine maintenance operations.
- Ensure there is a sufficient space in height to enable the ram lifting and easy access to the air regulation groups.
- For the pneumatic ram feeding, use a tube with an internal diameter no lower than 10 mm.

 **Install a condensate filter and a shut-off valve type ON-OFF on the air supply line to the ram.**

- Make sure the air governors to the pump and ram are closed. (turn counterclockwise the control knob to close them).
- Make sure the air delivery valve to the shovel plate is closed.
- Make sure the air delivery pipe to the pneumatic pump is connected to the ram and to the pump.
- Make sure the air delivery pipe to the shovel plate is connected to the ram and to the shovel plate.

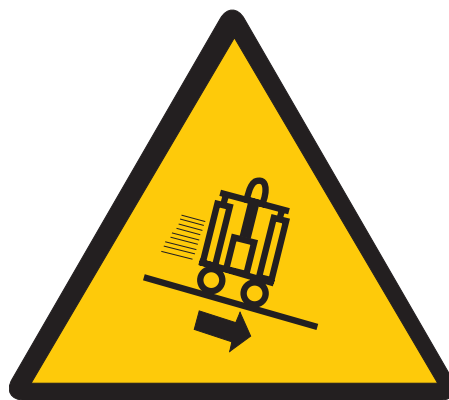

 It indicates the danger of carriage unexpected movement on slanting surfaces

F WORKING



Check all the fittings for the connection of the different components (pump, flexible hose, gun, etc.) before using the equipment avoid approaching too much to the ram during the ascent and descent functions.



- Open the air supply to the ram.
- Turn the lifting control lever (F1) upwards.

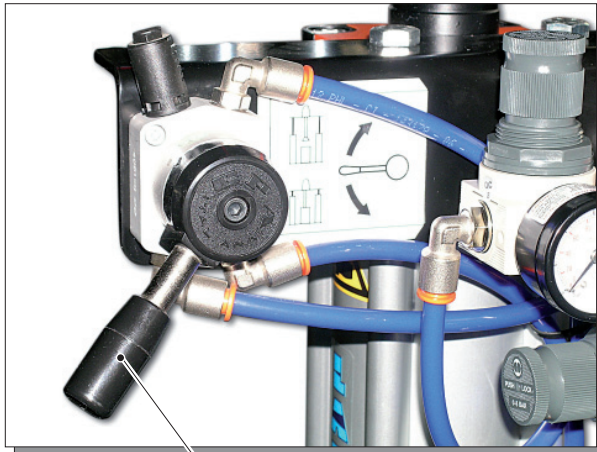

F1

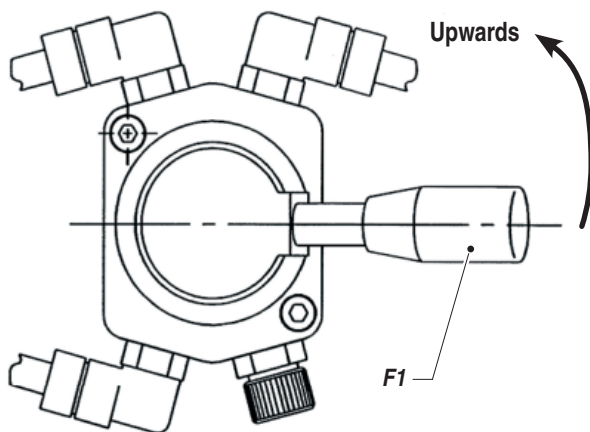

- Acting on the air (F2) governor to the ram, gradually increase the feeding pressure to the pneumatic cylinder (F3) till the ram starts lifting. Let the ram reaches its maximum height.
- Remove the cover from the drum (F4) to be used.

Ram air governor

F2

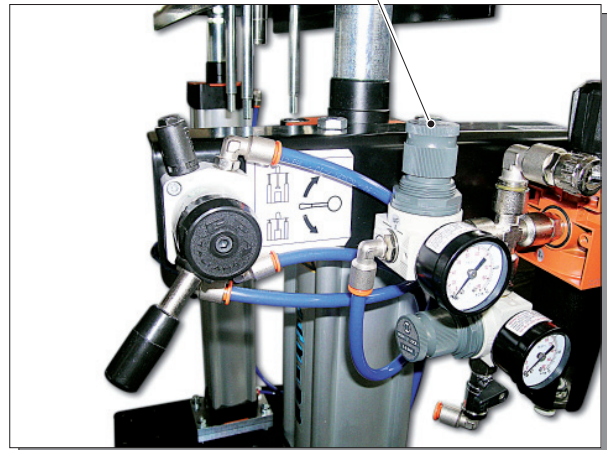

F3

F4



Check if there are any dents on the drum (F4): they could clock the shovel plate (F5) of the ram inside the drum.



F5

- Place the drum (F4) on the ram's plate (F6) and tighten the drum-block.



Drum-block

F6

- Turn the control lever (F1) downwards till the shovel plate (F5) lower near the upper edge of the drum (F4).

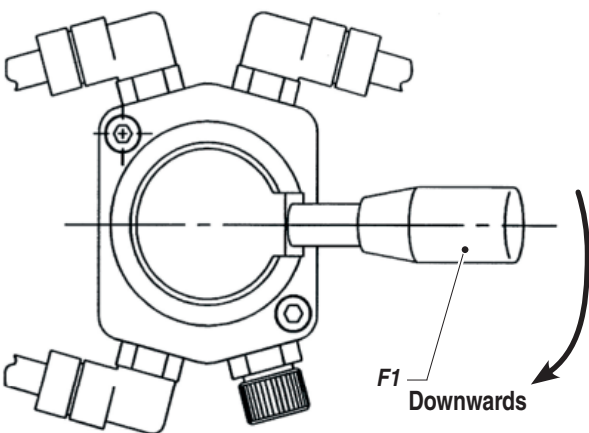

- Stop the descent of the ram by turning the control lever (F1) to the intermediate position.
- Center the drum (F4) correctly so as it is in axis with the shovel plate (F5).

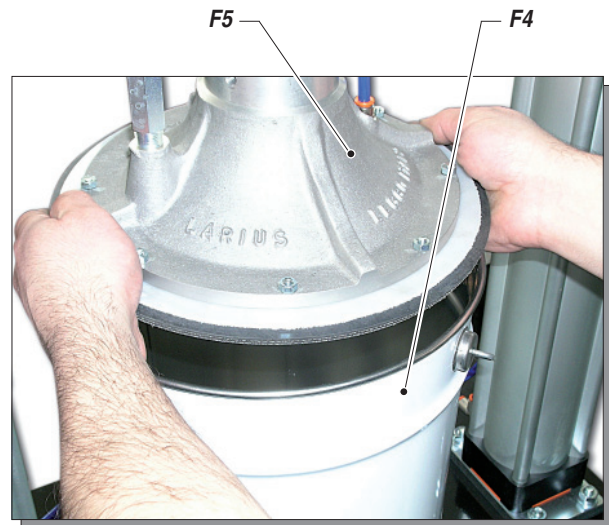
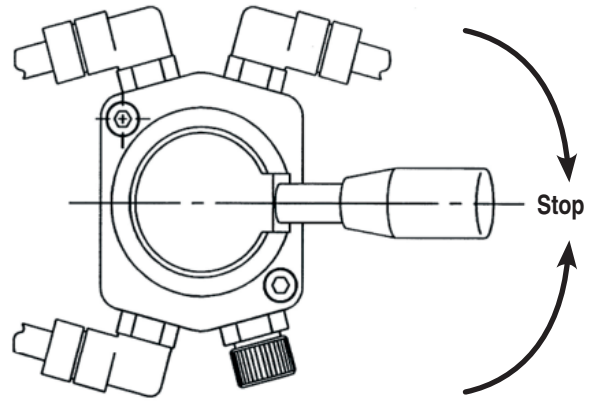

Center the drum

- Tighten the drum-block (F6).
- Open the bleeder valve placed (F7) on the shovel plate (F5).

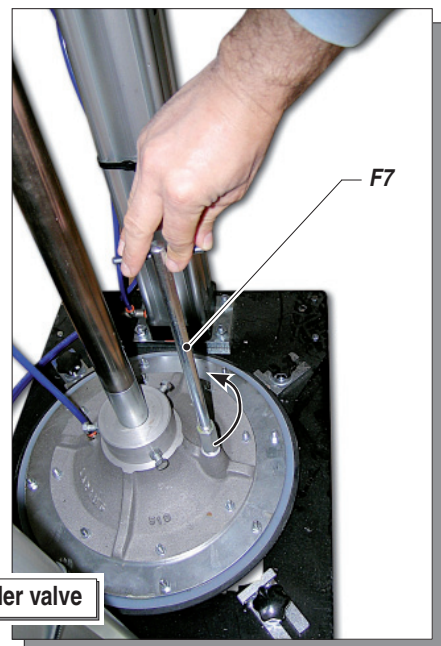

Open the bleeder valve

- Turn the control lever (F1) downwards let the shovel plate (F5) enter into the drum (F4).
- Close the bleeder valve (F7) of the shovel plate (F5).

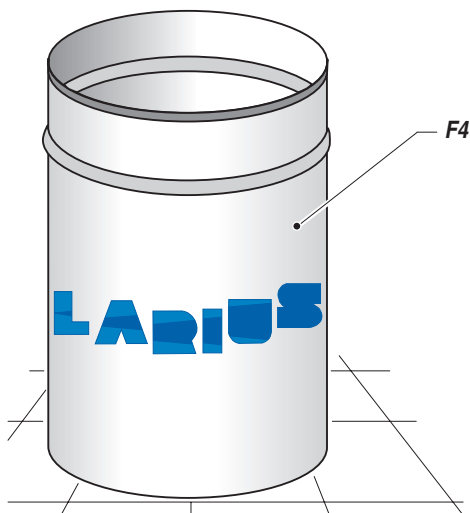
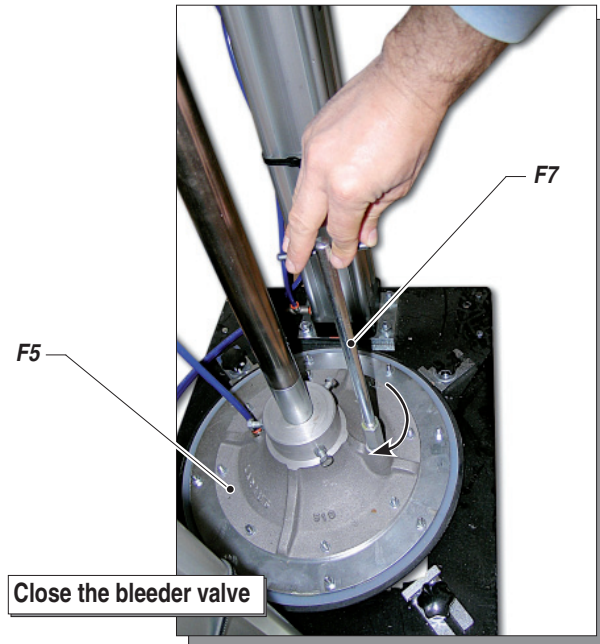
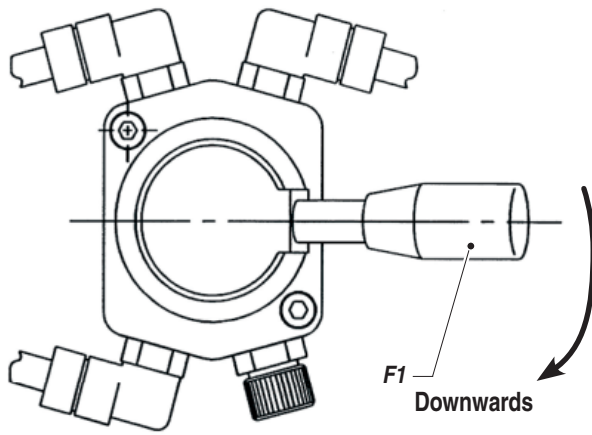

- Open the air (F8) passage valve on the pneumatic pump (F9).
- Allow the compressed air flow into the pump (F9) acting on the air governor placed on the ram. It is advised to adjust the air pressure to the minimum value necessary to a continuous working.

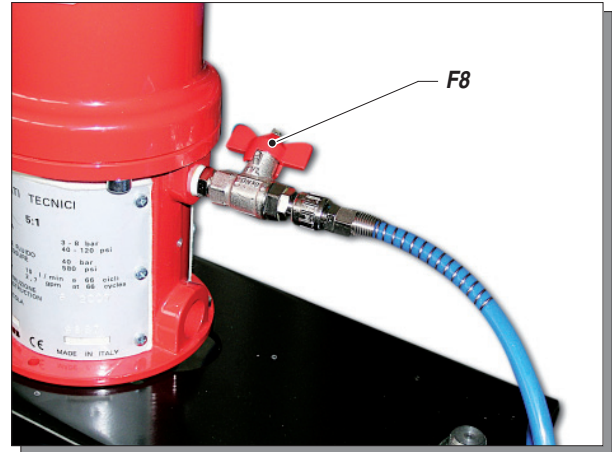

Pump air valve

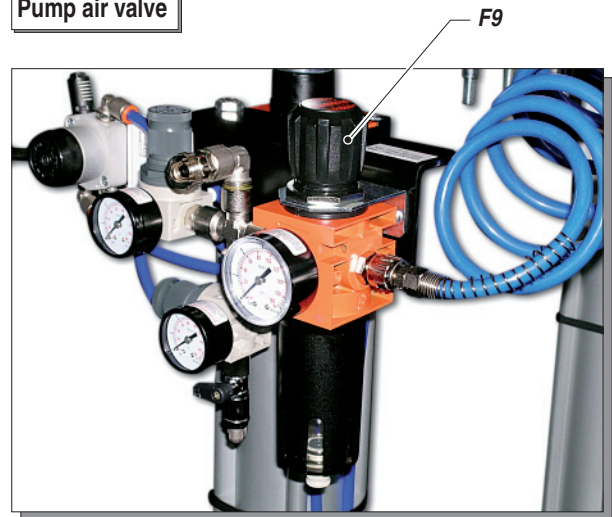

Air pump regulator

- To make the bleed of the pumping, read the pump manual.
- The pump will start working and then will stop when all the chamber of the product is full. The pump will start working any time the trigger of the gun is pushed or the delivery valve is open.
- In case of difficult suction of the pump, slowly open the bleeder valve placed (F7) on the shovel plate (F6) and close it when some product comes out from the bleeder fitting.



Never let the pump idle for a long period: it could damage the pneumatic motor and ruin the seals.

G REPLACEMENT OF THE DRUM

- Close the air supply to the pump (G1).
- Turn the lifting control lever upwards.
- Gradually open the air delivery valve (G2) to the shovel plate in order to facilitate the extraction of the shovel plate (G3) from the drum (G4).
- Let the ram reach its maximum height.
- Remove the empty drum and replace it with a full one.

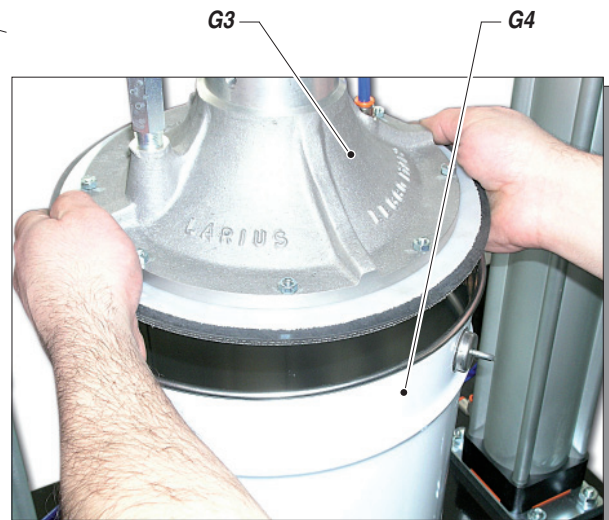
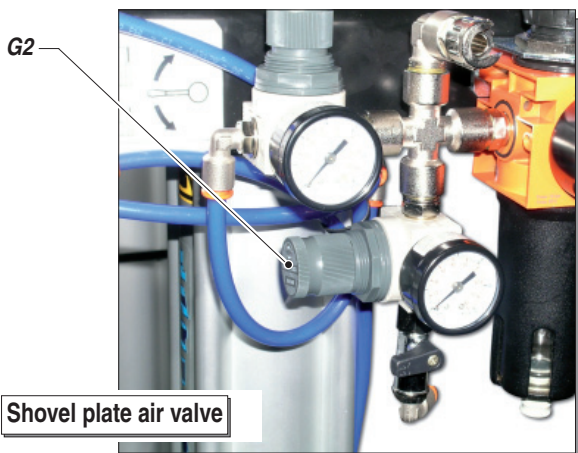
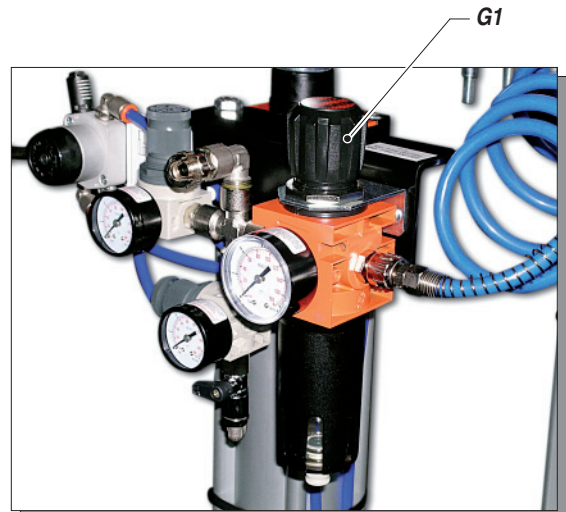

H ROUTINE MAINTENANCE



Always close the air compressed supply and release pressure in the circuit before performing any check or maintenance operation of the pump.

- Periodically check on the air supply to the ram. Make sure that air is always clean and lubricated.
- Periodically check if the gasket of the shovel plate are worn.
- Follow the instructions on the maintenance of the pneumatic pump contained in the user's manual.

I PROBLEMS AND SOLUTION

Problem	Problem possible cause	Solution
<ul style="list-style-type: none"> • The ram does not lift 	<ul style="list-style-type: none"> • The feed air pressure is too low; • The control lever is not in the high position; • The shovel plate is blocked on the drum; 	<ul style="list-style-type: none"> • Increase air pressure; • Turn the lifting control lever upwards; • Gradually open the bleeder delivery valve to the shovel plate so as to facilitate coming out of the drum;
<ul style="list-style-type: none"> • Leakage of material from the edges of the drum 	<ul style="list-style-type: none"> • Shovel plate gasket worn; • The feed air pressure of the pneumatic cylinder is too high. 	<ul style="list-style-type: none"> • Replace the gasket; • Reduce air pressure.



Always close the compressed air supply and release the pressure in the plant before performing any check or replacement of parts of the pump

L SPARE PARTS

WARNING: Always indicate code and quantity for each part required.

English

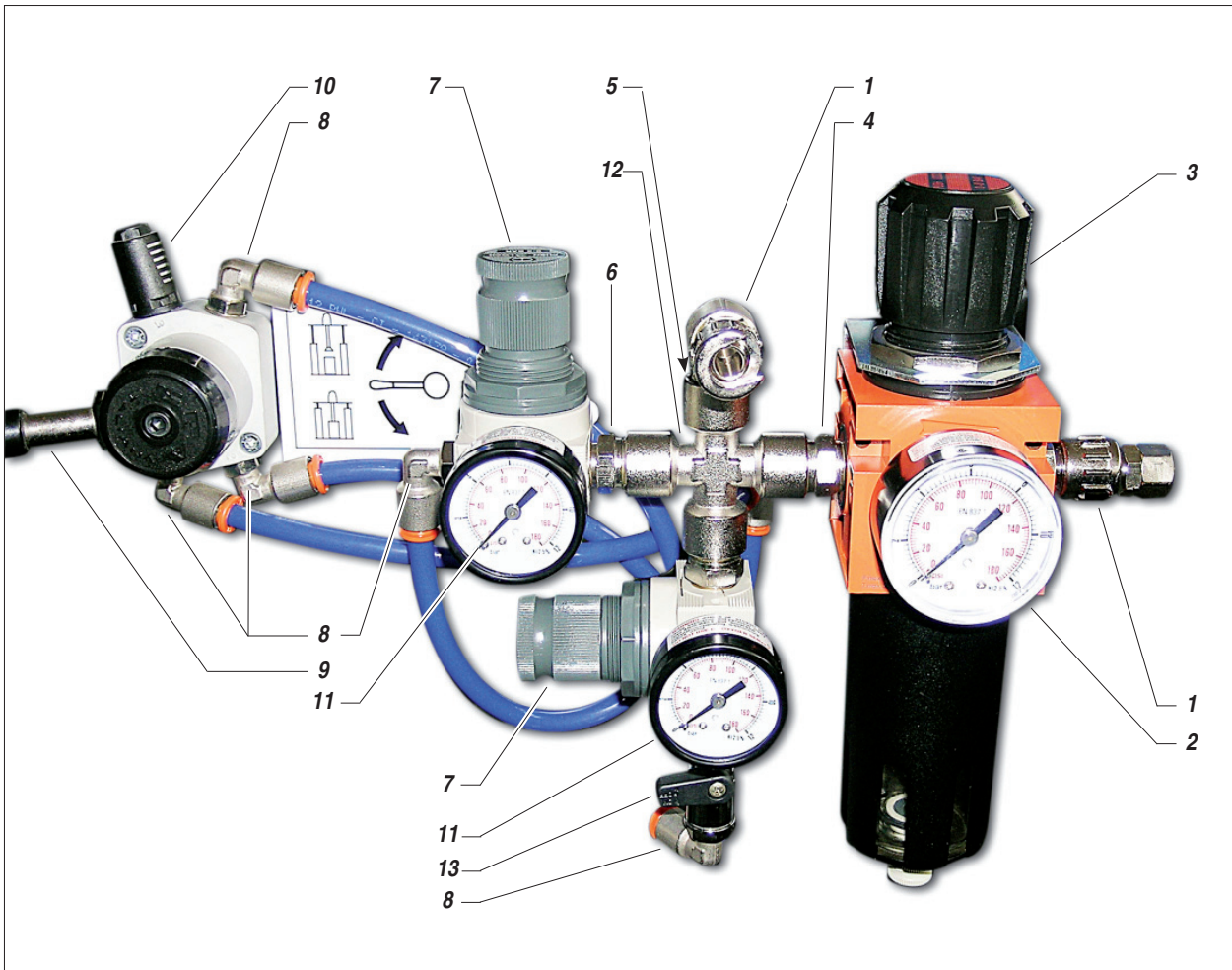

Pos.	Code	Description	Q.ty	Pos.	Code	Description	Q.ty
1	10103	Bayonet connection	2	8	11797	Revolving elbow	4
2	96259	Manometer	1	9	510438	Lever-operated valve	1
3	91107	Governor filter	1	10	510423	Silencer	1
4	91020	Reduction	1	11	8167	Manometer	1
5	91102	Elbow M-F 1/4	1	12	3348	Cross joint	1
6	3560	Nipples M-M 1/4	2	13	3347	Metering valve	1
7	3344	Governor	1				

M VERSIONS

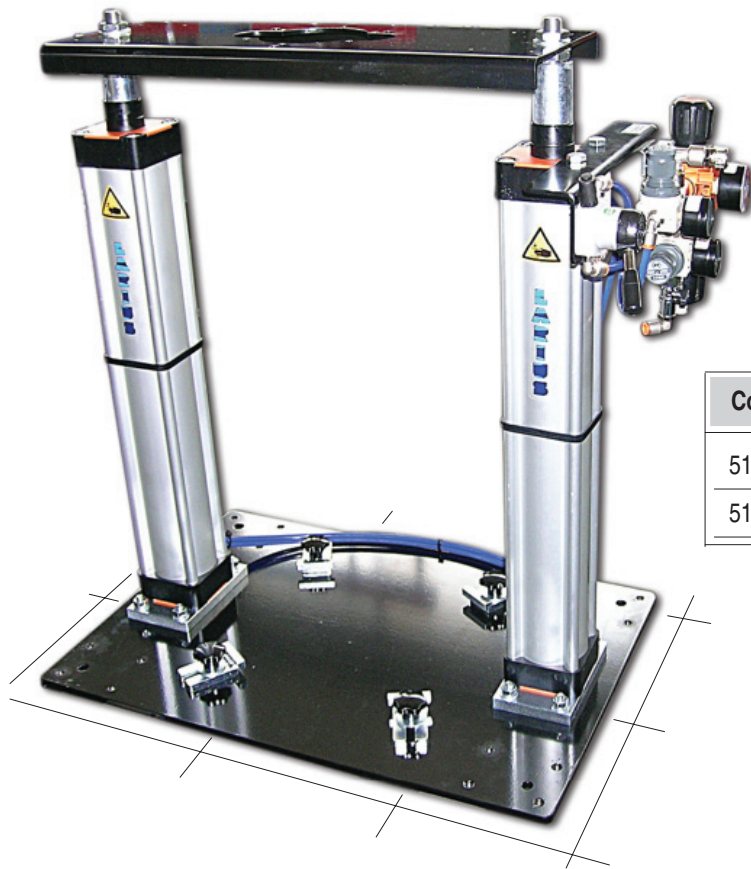

Code	Description
510412	Pneumatic cylinder
510431	Gasket kit pneumatic cylinder

Due to a constant product improvement programme, the factory reserves the right to modify technical details mentioned in this manual without prior notice.

MANUFACTURER:

LARIUS

23801 CALOLZIOCORTE - LECCO - ITALY - Via Stoppani, 21
Tel. (39) 0341/62.11.52 - Fax (39) 0341/62.12.43
E-mail: larius@larius.com - Internet <http://www.larius.com>



DIRECT LINE

CUSTOMERS TECHNICAL SERVICE

Tel. (39) 0341/621256
Fax (39) 0341/621234