

STEVAL-MKI062V2, iNEMO™ (iNertial MOdule) demonstration board based on MEMS devices and STM32F103RE

Introduction

The STEVAL-MKI062V2 is the second generation of the iNEMO™ module family. It combines accelerometers, gyroscopes and magnetometers with pressure and temperature sensors to provide 3-axis sensing of linear, angular and magnetic motion, complemented with temperature and barometer/altitude readings, representing the new ST 10 degrees of freedom (DOF) platform.

The STEVAL-MKI062V2 represents a further step in miniaturization in the iNEMO family. It integrates five STMicroelectronics sensors: a 2-axis roll-and-pitch gyroscope, a 1-axis yaw gyroscope, a 6-axis geomagnetic module, a pressure sensor, and a temperature sensor.

This 10-DOF inertial system represents a complete hardware platform that can be used in many applications, such as gaming, location-based service, human machine interfaces, and robotics.

A complete set of communication interfaces with various power supply options in a small size form factor (4 x 4 cm) make the iNEMO a flexible and open demonstration platform.

Figure 1. iNEMO V2 platform

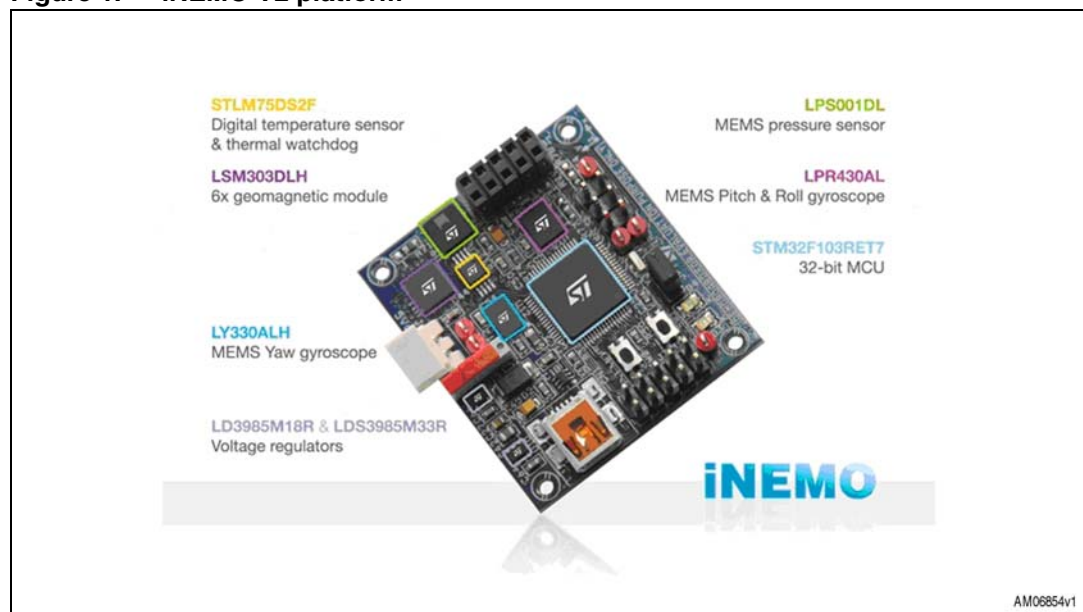

Contents

- 1 Overview 5**
 - 1.1 Features 5
 - 1.2 Demonstration software 5

- 2 Hardware layout and configuration 6**
 - 2.1 Power supply 8
 - 2.2 MCU 9
 - 2.3 Clock source 10
 - 2.4 Reset source 10
 - 2.5 Roll and pitch gyroscope 10
 - 2.6 Yaw axis gyroscope 13
 - 2.7 Accelerometer-magnetometer module 14
 - 2.8 Pressure sensor 15
 - 2.9 Temperature sensor 15
 - 2.10 Extended connector 16
 - 2.11 MicroSD card 16
 - 2.12 COM connector 17
 - 2.13 USB 18
 - 2.14 User LED and button 18

- Appendix A Schematics 19**

- Appendix B Bill of materials 21**

- Revision history 26**

List of tables

Table 1.	Power supply selector	8
Table 2.	LPR430AL configuration scheme	11
Table 3.	LPR430AL-ADC connection	11
Table 4.	LPR430AL filter enable/disable options	12
Table 5.	LPR430AL Sleep mode and power-down mode configuration	12
Table 6.	LY330ALH ADC connection	13
Table 7.	LY330ALH filter enable/disable options	13
Table 8.	Sleep mode and Power-down mode configuration	14
Table 9.	LSM303DLH I ² C addresses	14
Table 10.	COM connector pin-out	17
Table 11.	USB mini-B connector pin-out	18
Table 12.	User LED and button GPIO	18
Table 13.	Bill of materials	21
Table 14.	Document revision history	26

List of figures

Figure 1.	iNEMO V2 platform	1
Figure 2.	Block diagram	6
Figure 3.	TOP layout description	6
Figure 4.	Bottom layout description	7
Figure 5.	Bottom layout description	7
Figure 6.	Power supply stage	9
Figure 7.	LPR430AL schematic	10
Figure 8.	LY330ALH schematic	13
Figure 9.	LSM303DLH schematic	14
Figure 10.	Pressure sensor schematic	15
Figure 11.	Temperature sensor schematic	16
Figure 12.	Extended schematic	16
Figure 13.	MicroSD slot schematic	17
Figure 14.	COM connector J4	17
Figure 15.	USB mini-B connector (CN1) and schematic	18
Figure 16.	STEVAl-MKI062V2 schematic	19
Figure 17.	JTAG SWD adapter board schematic	20

1 Overview

1.1 Features

- Two power supply options: external power connector and USB connector
- STM32F103RET: low power high performance 32-bit microcontroller powered by ARM® Cortex™-M3
- LPR430AL: 2-axis gyro (roll, pitch) selectable full-scale 300-1200 dps (degrees per second), analog output, optional HP (high-pass) and LP (low-pass) filters
- LY330ALH: 1-axis gyro (Yaw) 300 dps full-scale, analog output, optional HP (high pass) and LP (low pass) filters
- LSM303DLH: 6-axis geomagnetic module, $\pm 2g/\pm 4g/\pm 8g$ linear acceleration full-scale, magnetic field configurable full-scale ± 1.3 to ± 8.1 gauss, I²C digital output
- LPS001DL: pressure sensor 300-1100 mbar absolute full-scale, I²C digital output, barometer
- STLM75: temperature sensor, -55 °C to +125 °C range, I²C digital interface
- Extended connector for wireless connectivity
- MicroSD card slot
- COM connector with RTS and CTS on TTL signals
- USB 2.0 full speed connection
- Reset button
- User LED and button

1.2 Demonstration software

To facilitate user development and sensor data analysis, the STEVAL-MKI062V2 demonstration kit includes a graphical user interface (GUI) to display sensor outputs, as well as a firmware library for easy development of customized applications. The latest version of the firmware package and PC GUI can be downloaded from the STEVAL-MKI062V2 web page on ST.com.

2 Hardware layout and configuration

The STEVAL-MKI062V2 demonstration board has been designed to manage all sensor features through the 32-bit STM32F103RE microcontroller. The hardware block diagram, in [Figure 2](#), illustrates the connections between the STM32F103RE peripherals and the sensors.

[Figure 3](#) and [4](#) show the location of these features on the demonstration board.

Figure 2. Block diagram

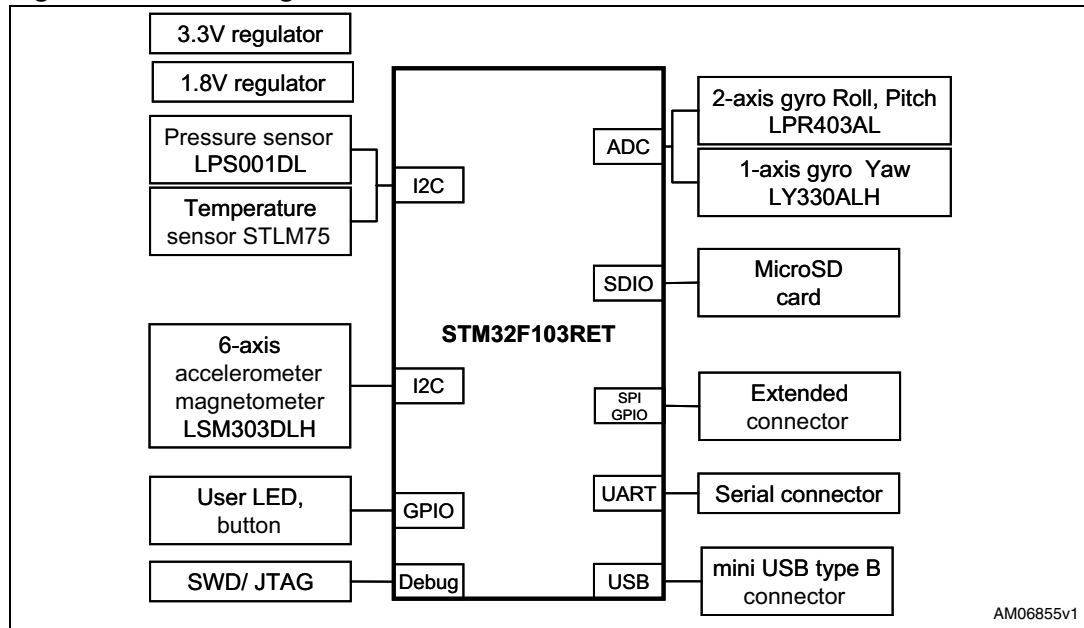

Figure 3. TOP layout description

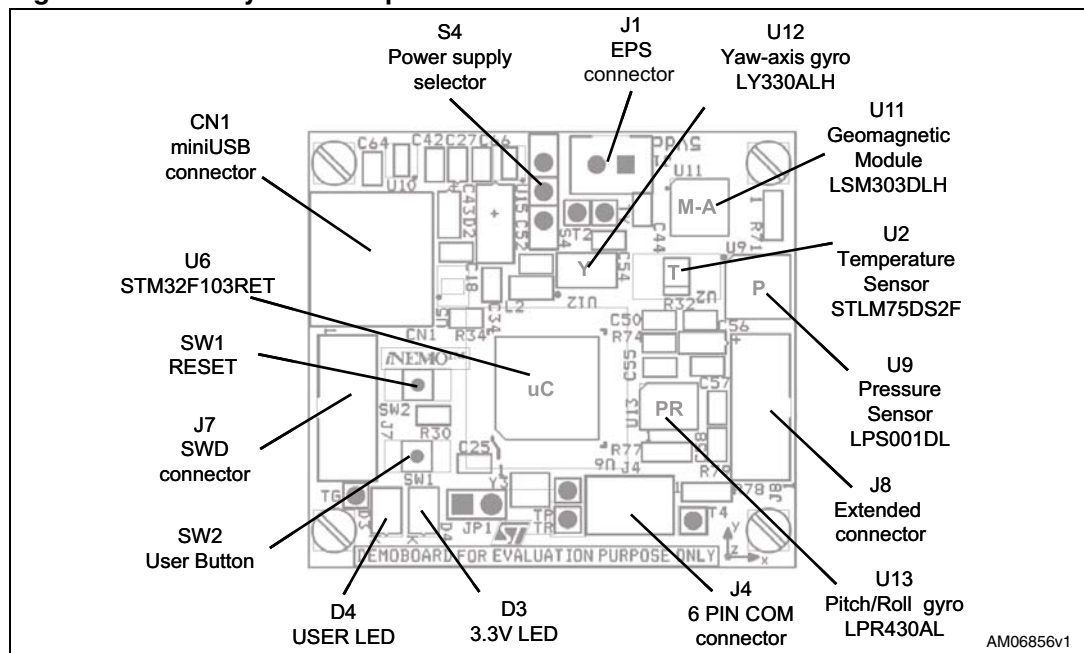
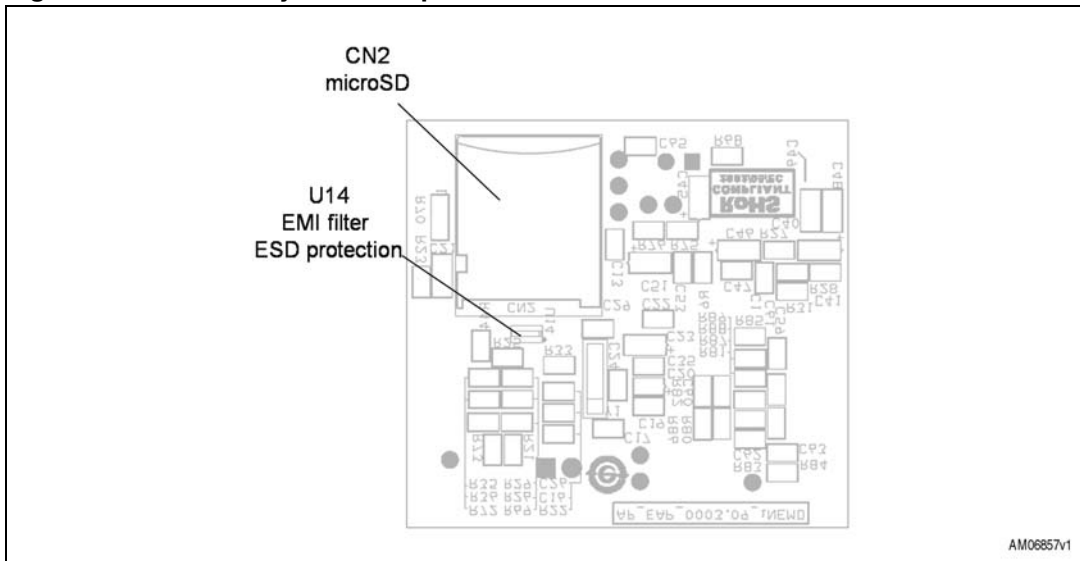

Figure 4. Bottom layout description



The reference system for the iNEMO platform is printed on the top side. *Figure 5* shows the axis orientation of each sensor in respect to the iNEMO local reference systems.

Note: *The positive Z-axis comes outwards from the board.*

Figure 5. Bottom layout description

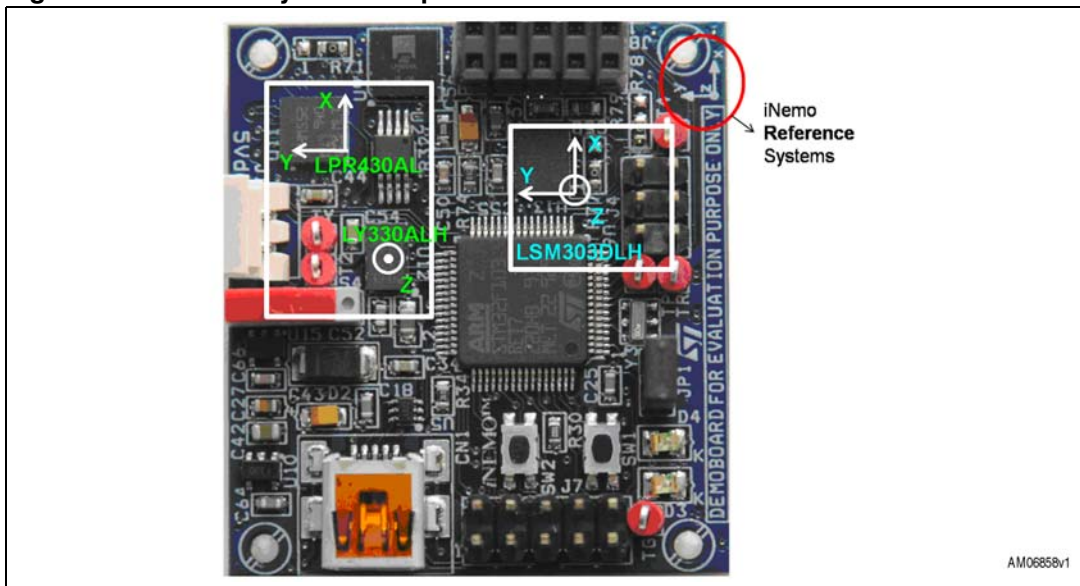

2.1 Power supply

The STEVAL-MKI062V2 hosts two ultra-low drop-low voltage regulators: the LD3985M18R for 1.8 V and the LDS3985M33R for 3.3 V. The 1.8 V is used to supply the digital part of the LSM303DLH, while the rest of the board works at 3.3 V.

The board can be powered by an external power supply voltage up to 6 V DC; the SMTY5 prevents the board from being damaged in the case of an accidental overload and in the case of reverse polarity.

It is possible to configure one of two power supply sources.

- 5 V DC power adapter connected to the J1 connector (5 V on silkscreen for power supply unit)
- 5 V DC power from CN1 type B USB connector.

The power supply option is configured by setting the S4 switch as shown in [Table 1](#). The D4 LED is turned on when the board is powered correctly.

Table 1. Power supply selector

Power source	S4 configuration
USB	
PSU	

The LDS3985xx and LD3985xx families are ultra-low drop-low noise BiCMOS voltage regulators for use with a very low ESR output capacitor. They are provided by an inhibit input voltage pin. When the voltage on this pin is below 0.4 V the voltage regulator is turned off, only when the voltage increases to 1.2 V does the device switch on. The output currents are up to 300 mA for the LDS3985xx family and up to 150 mA for the LD3985xx.

The 3.3 V power supply can be enabled by 1.8 V power stage or through an external power supply by soldering a 0 Ω resistor in the R70 position ([Figure 5](#)).

Figure 6. Power supply stage

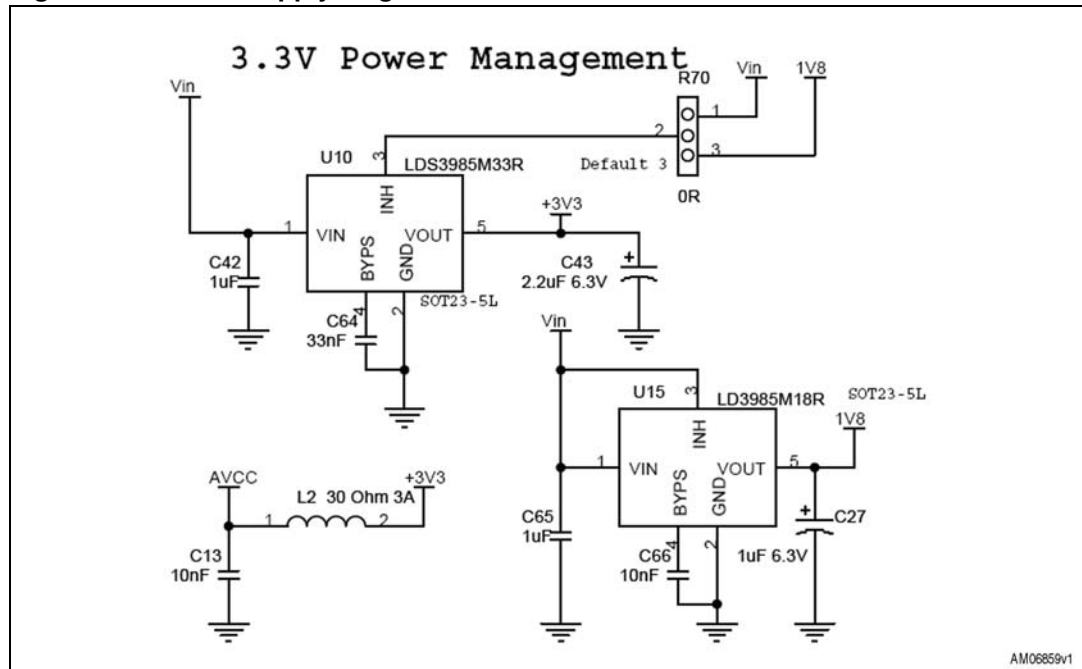

After you click the “Finish” button, you will find that the software is installed in the selected directory or in the default directory. The shortcut for this software is also available in the Start menu. The help file on how to use DLL is also available in the same directory.

2.2 MCU

The STEVAL-MK1062V2 demonstration board hosts an STM32F103RET.

The high density STM32F103xCDE performance line family incorporates the high-performance ARM® Cortex™-M3 32-bit RISC core, operating at up to 72 MHz, high-speed embedded memories (Flash memory up to 512 Kbytes and SRAM up to 64 Kbytes), and an extensive range of enhanced I/Os and peripherals connected to two APB buses.

All devices offer three 12-bit ADCs, four general purpose 16-bit timers plus one PWM timer, as well as standard and advanced communication interfaces: up to two I²Cs, three SPIs, five USARTs, an USB and an SDIO.

The STM32F103xx performance line family operates from a 2.0 to 3.6 V power supply. It is available in both the -40 to +85°C temperature range and the -40 to +105°C extended temperature range. A comprehensive set of power-saving modes allows the designing of low-power applications.

The complete STM32F103xx performance line family includes devices in 5 different package types: from 36 pins to 100 pins. Please refer to the STM32F103xx datasheet and reference manual for details of its characteristics.

2.3 Clock source

Two external clock sources are available on the STEVAL-MKI062V2 demonstration board for STM32F103RET and RTC:

- Y1, 32.768 kHz crystal for embedded RTC
- Y2, 8 MHz. It can be removed when the STM32F103RET's internal RC clock is used. Y2 does not need external capacitances.

2.4 Reset source

The reset signal of the STEVAL-MKI062V2 demonstration board is low-active and the reset sources include:

- SW1 reset button
- Debugging tool from SWD/JTAG connector J7.

The JP1 jumper enables a reset of the STM32F103RET embedded JTAG TAP controller each time a system reset occurs. JP1 connects the TRST signal from the JTAG connection with the system reset signal RESET#. Default setting: not fitted

2.5 Roll and pitch gyroscope

The STEVAL-MKI062V2 is provided with the LPR430AL bi-axial gyroscope; it is a low-power two-axis micro machined gyroscope able to measure angular rate along pitch and roll axes. The LPR430AL has a full-scale of ± 300 or ± 1200 dps and it is capable of detecting rates with a -3 dB bandwidth up to 140 Hz. Please refer to the respective datasheet for details of its characteristics. [Figure 7.](#) shows the application hints.

Figure 7. LPR430AL schematic

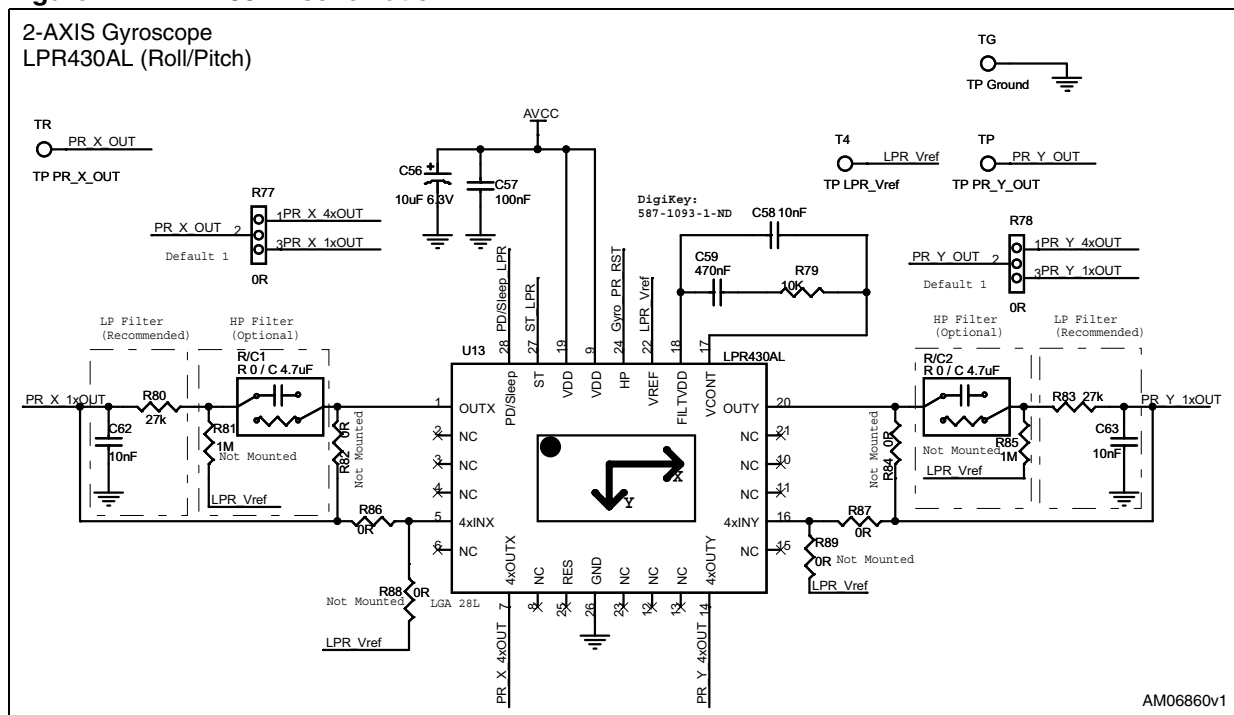

For each axis, the LPR430AL has two separate pins for the two full-scale 300-1200 dps.

With the STEVAL-MKI062V2 the user can select the full-scale, as described in [Table 2](#), according to the filter setting, as detailed in the datasheet.

Table 2. LPR430AL configuration scheme

Full-scale	axis	Enable	External filter	
300 dps	x	R77= 0 Ω in position 1	Disabled	R82 = 0 Ω R86 = 0 Ω R88 = Do not assemble
			Enabled	R82 = Do not assemble R86 = 0 Ω R88 = Do not assemble
	y	R78= 0 Ω in position 1	Disabled	R84 = 0 Ω R87 = 0 Ω R88 = Do not assemble
			Enabled	R84 = Do not assemble R87 = 0 Ω R89= Do not assemble
1200 dps	x	R77= 0 Ω in position 3	Disabled	R82 = 0 Ω R86 = Do not assemble R88 = 0 Ω
			Enabled	R82 = Do not assemble R86 = Do not assemble R88 = 0 Ω
	y	R77= 0 Ω in position 3	Disabled	R84 = 0 Ω R87 = Do not assemble R89= 0 Ω
			Enabled	R84 = Do not assemble R87 = Do not assemble R89= 0 Ω

The net PR_X_OUT, PR_Y_OUT, and LPR_Vref are connected to the ADC pins of the STM32. (See [Table 3](#)).

The analog outputs of the LPR430AL can be analyzed through an oscilloscope, using the test point TP, TR, TG (ground) and T4.

Note: It is recommended to put the respective pin of the STM32F103 into input floating mode.

Table 3. LPR430AL-ADC connection

Gyro output	GPIO	ADC_IN
PR_X_OUT	PC0 (TR)	ADC_IN_10
PR_Y_OUT	PC1 (TP)	ADC_IN_11
LPR_Vref	PC2 (T4)	ADC_IN_12

The STEVAL-MKI062V2 output-rate response of the LPR430AL can be band-limited through the use of an external low-pass filter and high-pass filter (optional, see [Figure 9](#)) in addition to the embedded low-pass filter ($f_t = 140$ Hz).

The cut-off frequency is set by the value of R and C in [Figure 9](#).

Equation 1

$$f_{HP} = \frac{1}{2\pi R_1 C_1} = 0.03\text{Hz}$$

Equation 2

$$f_{LP} = \frac{1}{2\pi R_2 C_2} \approx 590\text{Hz} \Big|_{C_2=10\text{nF}, R_2=27\text{k}\Omega}$$

For each gyro output the filter can be disabled, as described in [Table 4](#).

Table 4. LPR430AL filter enable/disable options

Axis	HPF		LPF	
4xOUTX LPR430AL	Enable	R/C1 = 4.7 uF R81 = 1 MΩ	Enable (default)	C62 = 10 nF R80 = 27 kΩ
	Disable (default)	R/C1 = 0 Ω R81 = Do not assemble	Disable	C62 = Do not assemble R80 = 0 Ω
4xOUTY LPR430AL	Enable	R/C2 = 4.7 uF R85 = 1 MΩ	Enable (default)	C63 = 10 nF R83 = 27 kΩ
	Disable (default)	R/C2 = 0 Ω R85 = Do not assemble	Disable	C63 = Do not assemble R83 = 0 Ω

The LPR430AL enables advanced power-saving features thanks to the availability of several operating modes: normal mode, power-down and sleep mode.

When the device is set in the sleep-mode configuration, the reading chain is completely turned off, resulting in low power consumption. In this condition the device turn-on time is significantly reduced, allowing simple external power cycling.

In accordance with the table below, the user can select the desired operating mode through the configuration of two dedicated LPR430AL pins (ST and SLEEP/PD).

In the STEVAL-MKI062V2, this operating mode is implemented using two STM32 GPIOs (PB1 e PB2) to manage the configurations.

Table 5. LPR430AL Sleep mode and power-down mode configuration

Operation mode	ST pin - PB1	SLEEP/PD pin - PB2
Normal mode	0	0
Power-down	0	1
Self-test	1	0
Sleep mode	1	1

2.6 Yaw axis gyroscope

In order to have a complete 3-axis system of gyroscopes, the STEVAL-MKI062V2 has the LY330ALH on-board and the high performance ± 300 dps analog yaw-rate gyroscope. The application schematic and the electrical connections are given in [Figure 8](#) and [Table 6](#):

Figure 8. LY330ALH schematic

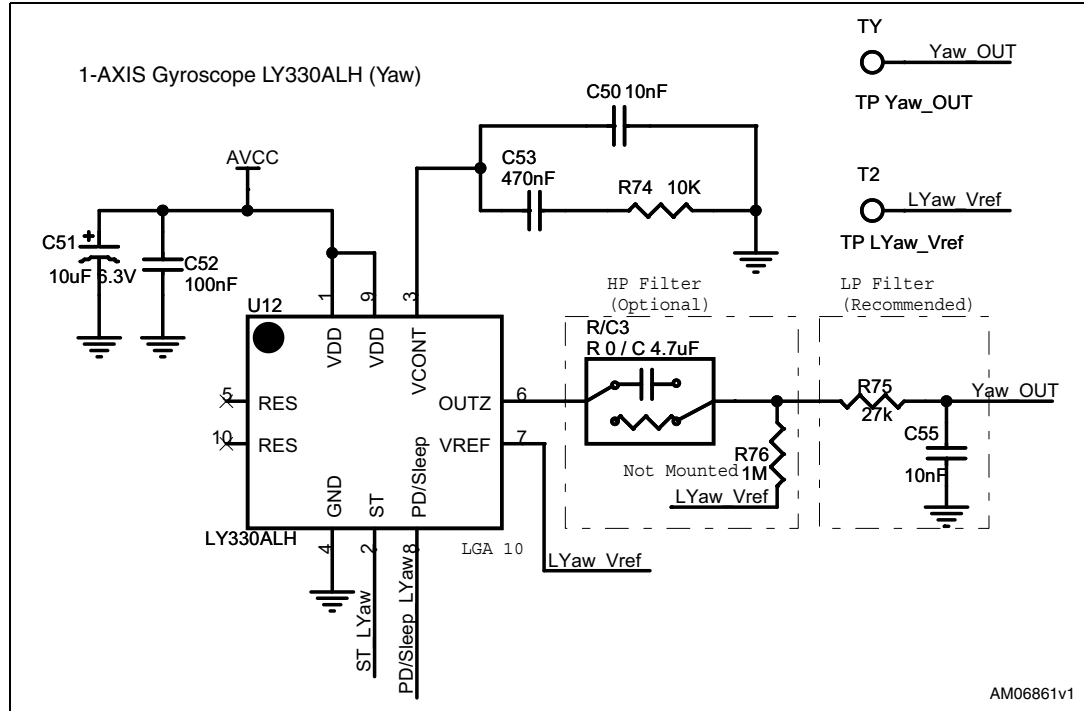

Table 6. LY330ALH ADC connection

Gyro Output	GPIO	ADC_IN	Test point
OUTZ	PC4	ADC_IN_14	TY
Yaw_Vref	PC5	ADC_IN_15	T2
ST_Yaw	PB14	/	/
PD/Sleep Yaw	PB15	/	/

As with the LPR430AL, the output rate response of the LY330ALH can also be band-limited, through the use of the same low-pass filter and high-pass filter (optional, see [Table 7](#)), in addition to the embedded low-pass filter ($f_t = 140$ Hz).

Table 7. LY330ALH filter enable/disable options

Axis	HPF		LPF	
	Enable	R/C3 = 4.7uF R76 = 1 M Ω	Enable (default)	C55 = 10 nF R75 = 27 k Ω
Disable(default)	R/C1 = 0 Ω R76 = Do not assemble	Disable	C55 = Do not assemble R75 = 0 Ω	

The power-saving features of the LY330ALH can be implemented as shown in [Table 8](#).

Table 8. Sleep mode and power-down mode configuration

Operation mode	ST pin	SLEEP/PD pin
Normal mode	0	0
Sleep mode	0	1
Self-test	1	0
Power-down	1	1

2.7 Accelerometer-magnetometer module

The LSM303DLH is a system-in-package featuring a 3D digital linear acceleration sensor and a 3D digital magnetic sensor. The LSM303DLH has a linear acceleration full-scale of ± 2 g / ± 4 g / ± 8 g and a magnetic field full-scale of ± 1.3 / ± 1.9 / ± 2.5 / ± 4.0 / ± 4.7 / ± 5.6 / ± 8.1 gauss, both fully selectable by the user. Magnetic and accelerometer parts can be enabled or put into power-down mode separately. [Figure 9](#) shows the LSM303DLH electrical connection (the configuration in use is the one recommended for I²C fast mode; see datasheet for details). The I²C addresses of the accelerometer and magnetometer parts are given in [Table 9](#).

Figure 9. LSM303DLH schematic

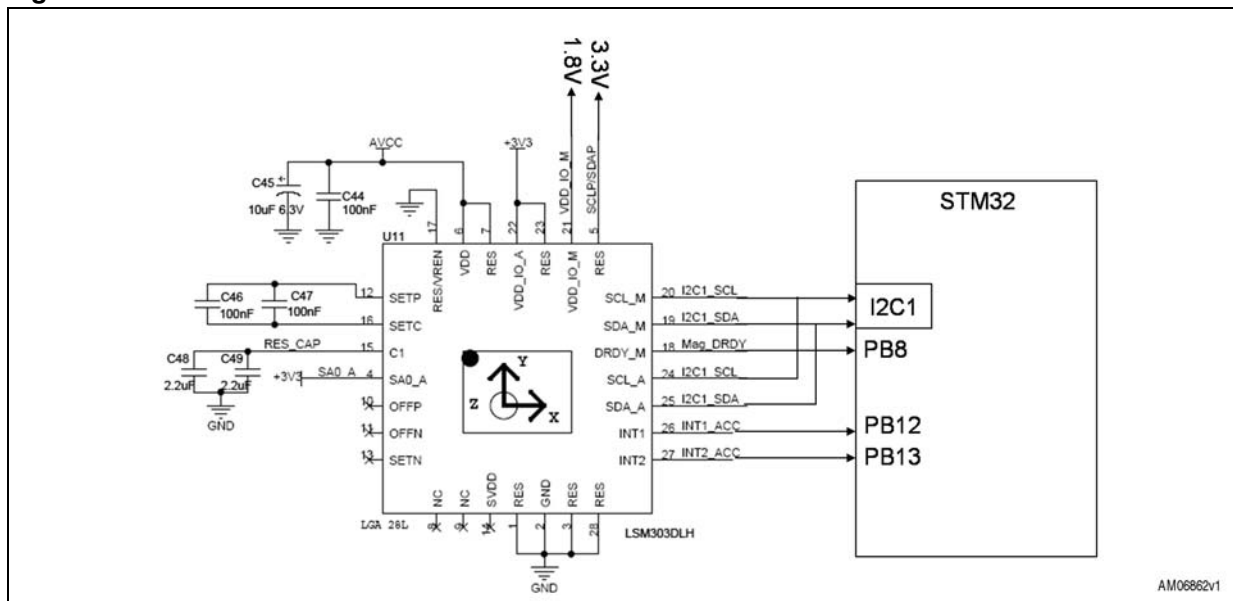

Table 9. LSM303DLH I²C addresses

Part	Read address	Write address
Accelerometer	0x33	0x32
Magnetometer	0x3D	0x3C

2.8 Pressure sensor

The LPS001DL is a high resolution, digital output pressure sensor packaged in an LGA holed package (STMicroelectronics patent pending). The complete device includes a sensing element based on a piezoresistive Wheatstone bridge approach, and an IC interface able to take the information from the sensing element to the external world, as a digital signal.

The STEVAL-MKI062V2 board uses an I²C communication and its slave address is set to 0xBA. The LPS001DL features two fully programmable interrupt sources (INT1 and INT2) which may be configured to trigger different pressure events. In the STEVAL-MKI062V2, only the INT1 interrupt source is connected to the MCU. The device may also be configured, through interrupt pins; a data ready signal (Drdy), which indicates when new measured data is available, therefore simplifying data synchronization in digital systems. The connection between the LPS001DL and the STM32F103 is shown in [Figure 13](#).

Figure 10. Pressure sensor schematic

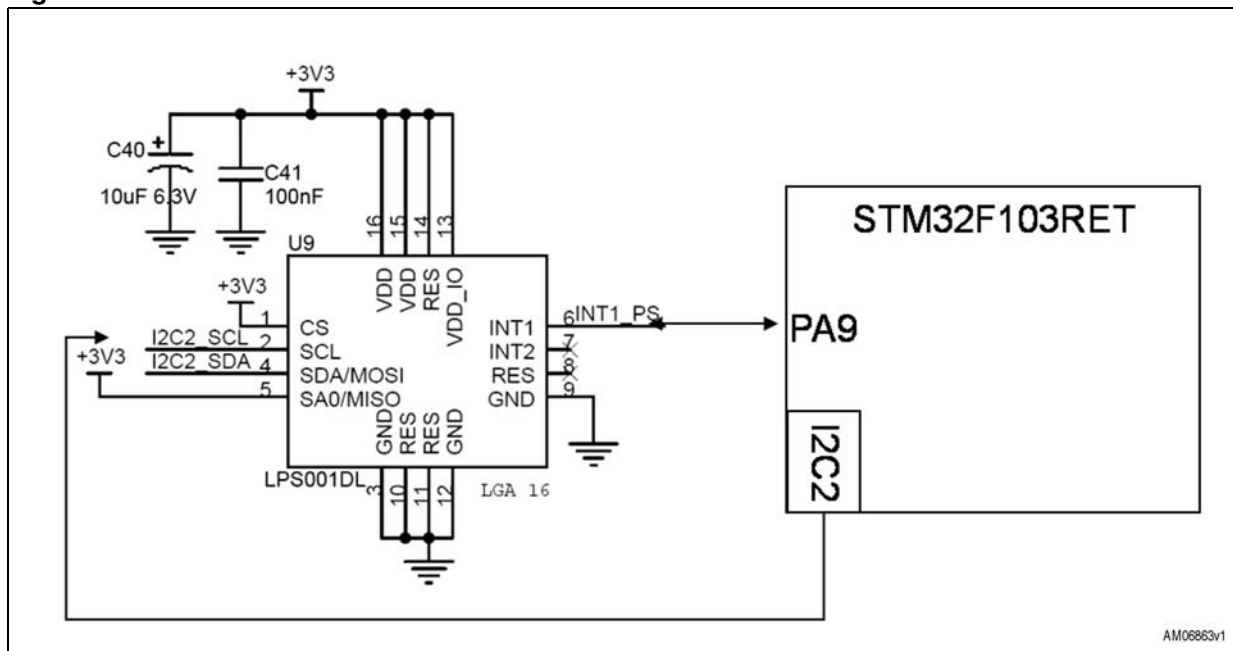

2.9 Temperature sensor

An I²C interface STLM75 temperature sensor (-55°C to +125°C) connected to the I²C of the STM32F103RET is available on the board.

As the STLM75 pins, A2, A1, and A0, are grounded, the slave address of the sensor is settled to 0x90. The STLM75 has a dedicated open drain Over-Limit Signal/Interrupt (OS/INT) output which features a thermal Alarm function. This function provides a user-programmable trip and turn-off temperature, and it can operate in either of the two selectable modes:

- Comparator mode
- Interrupt mode

The application schematic of the STLM75 is shown in [Figure 11](#).

Figure 11. Temperature sensor schematic

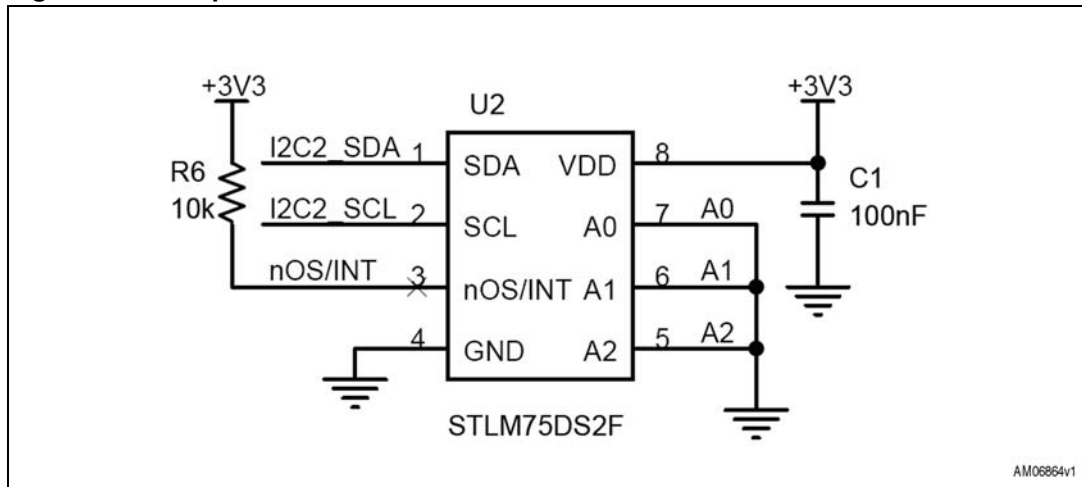

2.10 Extended connector

The interface capability of the STEVAL-MKI062V2 can be extended through the J8 connector. It provides an SPI interface and 4 GPIOs. (The PA8 pin can also be configured as a master clock output, in order to have the MCU clock available on the connector).

Figure 12. Extended schematic

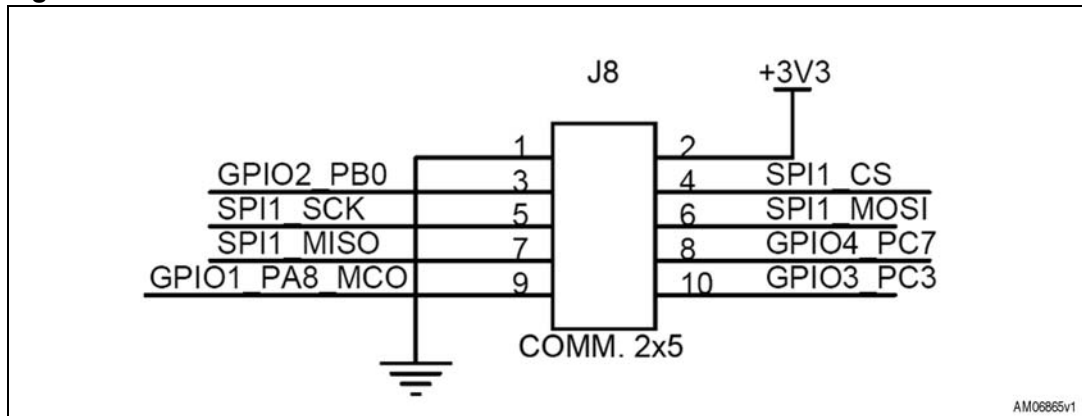

2.11 MicroSD card

The MicroSD slot CN2 ([Figure 15](#)) is available on the bottom side of the STEVAL-MKI062V2; it is connected to the SDIO of the STM32F103RET, as shown in [Figure 13](#).

The EMIF06-MSD02N16 suppresses EMI/RFI noise for interface line filtering. This filter includes ESD protection circuitry, which prevents damage to the protected device when subjected to ESD surges.

Figure 13. MicroSD slot schematic

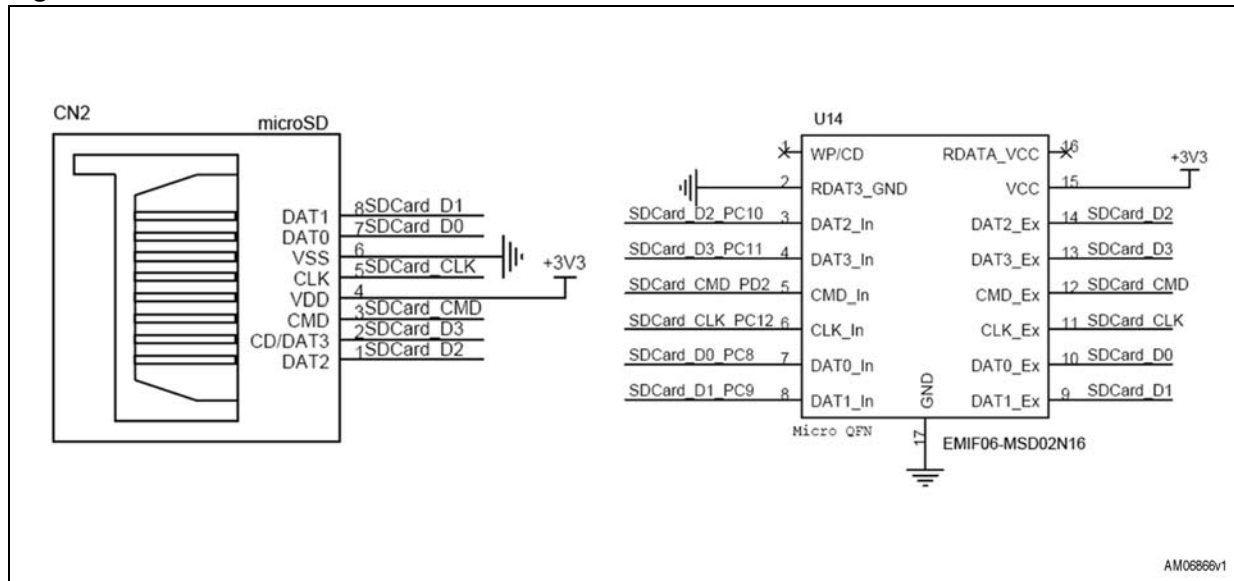

2.12 COM connector

The 6-pin COM J4 connector is connected to the UART2 pins of the STM32F103RET, as shown in [Figure 14](#) and [Table 10](#). It presents the hardware data-flow control through the CTS and RTS signals.

Note: J4 does not offer any transceiver; it is directly connected to the microcontroller pins. As this prevents any overload/over-voltage on these pins.

Moreover, J4 connector also provides a 3.3 V pin which can be used to supply a RS232 transceiver. Sinking too much current from this pin could damage the board.

Figure 14. COM connector J4

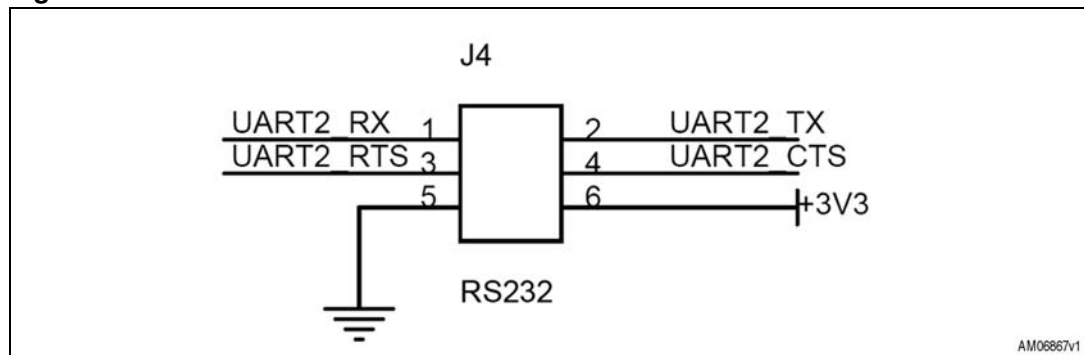

Table 10. COM connector pin-out

Pin number	Description	Pin number	Description
1	UART2_RX (PA3)	4	UART2_CTS(PA0)
2	UART2_TX (PA2)	5	GND
3	UART2_RTS (PA1)	6	3V3

2.13 USB

The STEVAL-MKI062V2 is provided with USB 2.0 compliant full-speed communication via a USB type mini-B receptacles connector (CN1), with dedicated EMI Filter and line termination through the USBUF02W6 (U5). The PA10 pin of the STM32F103 is used for software connection/disconnection of the USB cable. The MCU pins are configured in output push-pull mode: when high, the USB communication is enabled; when low, it is disabled.

Figure 15. USB mini-B connector (CN1) and schematic

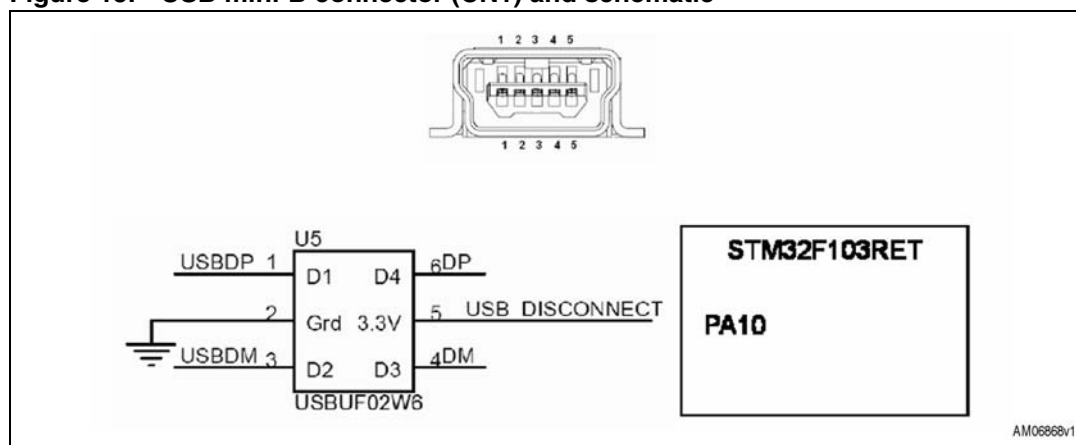

Table 11. USB mini-B connector pin-out

PIN number	Description
1	Vbus (power)
2	DM (PA11)
3	DP (PA12)
4	N.C.
5	Ground

2.14 User LED and button

In the STEVAL-MKI062V2 demonstration board, one D3 LED and one SW2 push button are available for user applications.

Table 12. User LED and button GPIO

Device	MCU GPIO
D3	PB9
SW2	PC13

Appendix A Schematics

Figure 16. STEVAL-MKI062V2 schematic

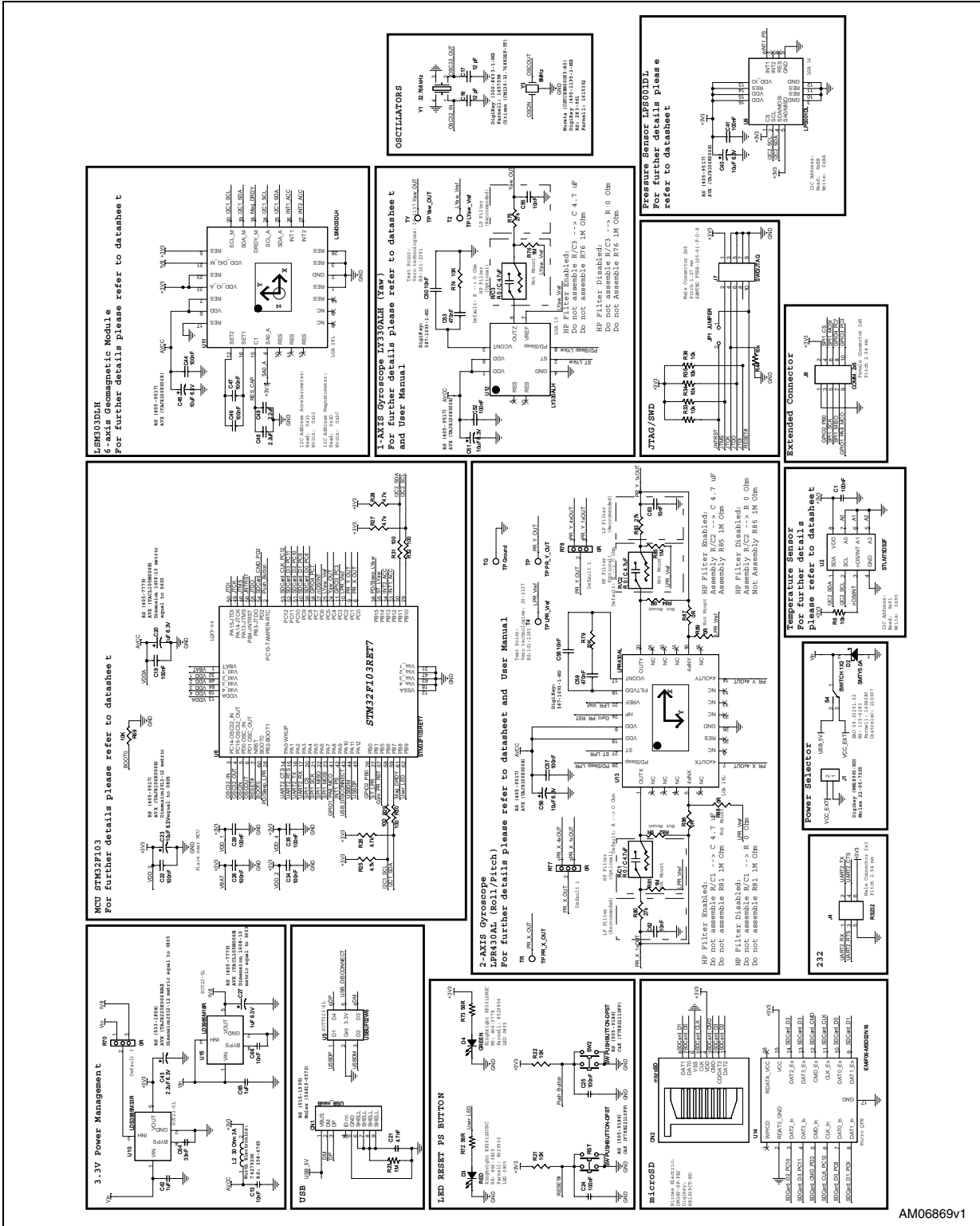

AM06869v1



Figure 17. JTAG SWD adapter board schematic

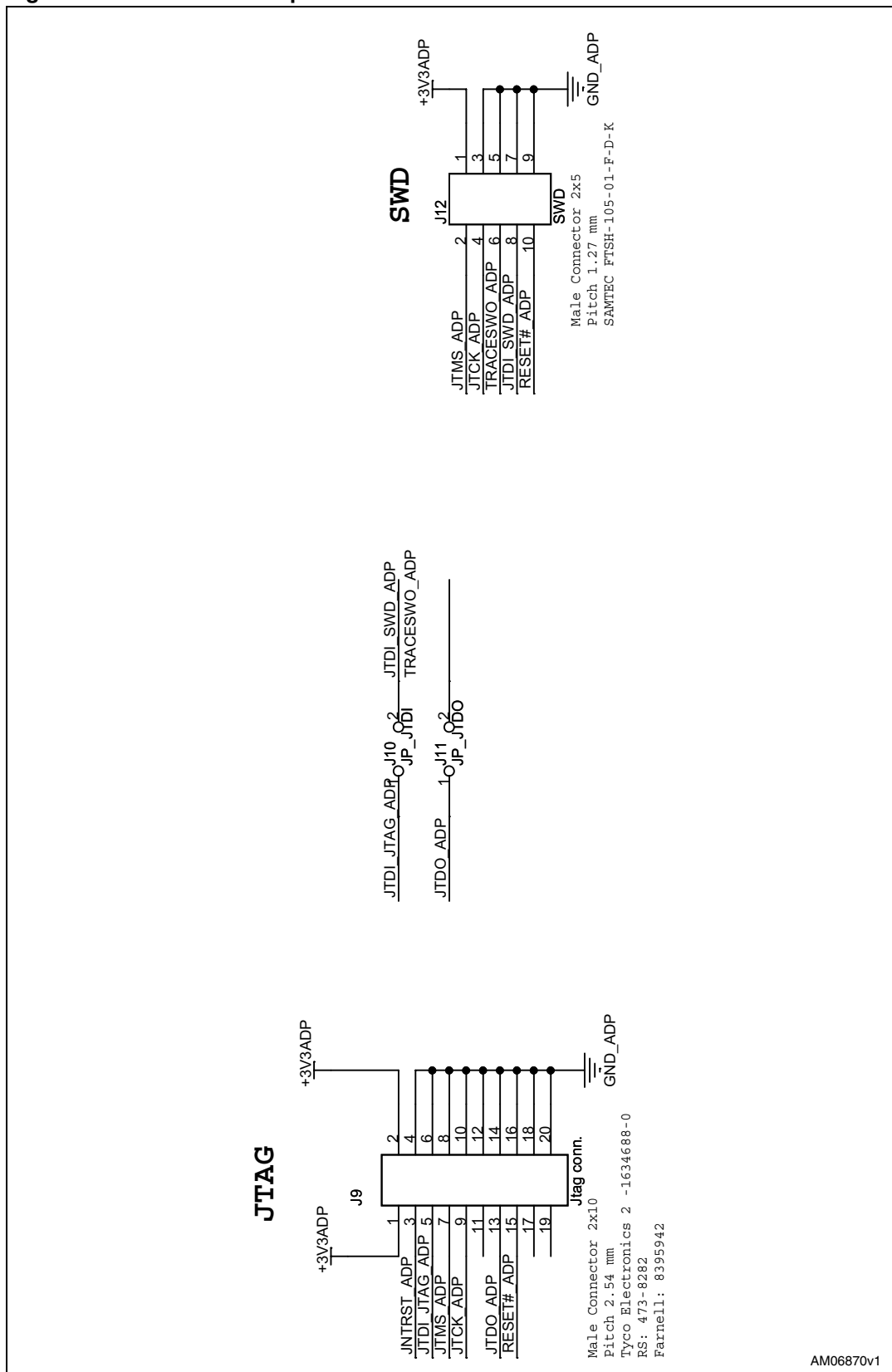



Appendix B Bill of materials

UM0937

Table 13. Bill of materials

Reference	Part / value	Voltage / watt / ampere	Package	Manufacturer	Manufacturer's ordering code / orderable part number	Supplier	Supplier's ordering code
CN1	USB_miniB			Molex	54819-0572	RS	RS: 515-1995
CN2	microSD			Hirose Electric	DM3AT-SF-PEJ	Digi-Key	Digi-key: HR1939CT-ND
C1,C19,C22, C24,C25,C26, C29,C34,C35, C41,C44,C46, C47,C52,C57	100 nF		SMD 0603	Any		Any	
C13,C50,C55, C58,C62,C63, C66	10 nF		SMD 0603	Any		Any	
C16,C17	12 pF		SMD 0603	Any		Any	
C20,C27	1 μ F 6.3 V	6.3 V Tantal	SMD 0603	AVX	TACL105M006R	RS	RS: 405-7779
C21	4.7 nF	100 V	SMD 0805	Any		Any	
C23,C40,C45, C51,C56	10 μ F 6.3 V	6.3 V Tantal	SMD 0805	AVX	TAJR106K006R	RS	RS: 405-9517
C42,C65	1 μ F		SMD 0603	Any		Any	
C43	2.2 μ F 6.3 V 2.2 μ F 10 V (opt)	6.3 V Tantal 10 V Tantal (opt)	SMD 0805	AVX	TAJR225K006R TAJR225K010R (opt)	RS Farnell RS	RS: 533-1804 Farnell: 197002 RS: 405-9545 (opt)
C48,C49	2.2 μ F		SMD 0805	Any		Any	
C53,C59	470 nF		SMD 0603	Any		Any	
C64	33 nF		SMD 0603	Any		Any	

Doc ID 17418 Rev 1

21/27

Bill of materials

Table 13. Bill of materials (continued)

Reference	Part / value	Voltage / watt / ampere	Package	Manufacturer	Manufacturer's ordering code / orderable part number	Supplier	Supplier's ordering code
D2	SMTY5.0A		SMA	STMicroelectronics	SMTY5.0A	ST	SMTY5.0A
D3	Red		SMD 0805	Kingbright	KP2012SURC	RS Farnell	RS: 466-3829 Farnell: 8529930
D4	Green		SMD 0805	Kingbright	KP2012MGC	RS Farnell	RS: 466-3778 Farnell: 8529906
JP1	Jumper		THR (spacing 2.54)	Any		Any	
J1	Battery connector		THR (spacing 2.54)	MOLEX	22-05-7025	Digi-Key	Digi-Key: WM18900-ND
J4	RS232 (Strip line male 6-pin 2x3)	THR (spacing 2.54)	Any		Any		
J7	SWD/JTAG (Male connector 10-pin 2x5)	THR (spacing 1.27)	SAMTEC	FTSH-105-01-F-D-K	Any		
J8	Communication connector (Strip line female 10-pin 2x5)	THR (spacing 2.54)	Any		Any		
L2	SMD ferrite 30 Ω 3 A	SMD 0805	Würth Electronics	74279206	RS	RS: 358-6765	
R/C1, R/C2, R/C3 (SMD resistor or SMD capacitor)	0 Ω 1%	Assemble	SMD 0603	Any		Any	
	4.7 μ F	Do not assemble					
RST,SW2	SW pushbutton DPST	SMD	C&K	Y78B22110FP	RS	RS: 505-9186	



Table 13. Bill of materials (continued)

Reference	Part / value	Voltage / watt / ampere	Package	Manufacturer	Manufacturer's ordering code / orderable part number	Supplier	Supplier's ordering code
R6,R21,R22, R33,R34,R35, R36,R44,R69, R74,R79	10 k Ω 1%		SMD 0603	Any		Any	
R23	1 M Ω 1%		SMD 0603	Any		Any	
R76,R81,R85	1 M Ω 1%	Do not assemble	SMD 0603	Any		Any	
R25,R26,R27, R28	4.7 k Ω 1%		SMD 0603	Any		Any	
R29,R30,R31, R32	100 Ω 1%		SMD 0603	Any		Any	
R86,R87	0 Ω 1%		SMD 0603	Any		Any	
R82, R84, R88, R89,	0 Ω 1%	Do not assemble	SMD 0603	Any		Any	
R77,R78	0 Ω 1%	Default position 1	SMD 0603	Any		Any	
R70	0 Ω 1%	Default position 3	SMD 0603	Any		Any	
R72,R73	56 Ω 1%		SMD 0603	Any		Any	
R75,R80,R83	27 k Ω 1%		SMD 0603	Any		Any	
S4	Switch 1X2		THR (spacing 2.54)	EAO	09.03201.02	RS Farnell Distrelec	RS: 115-6283 Farnell: 1608080 Distrelec: 210007
TG, TP, TR, TY, T2, T4	Test points	Do not assemble	THR	Keystone Electronics	5001 (5000)	Digi-key	5001K-ND (5000K-ND)
U2	STLM75DS2F		MSOP8 (TSSOP8)	STMicroelectronics	STLM75DS2F	STMicroelectronics	STLM75DS2F

**Table 13. Bill of materials (continued)**

Reference	Part / value	Voltage / watt / ampere	Package	Manufacturer	Manufacturer's ordering code / orderable part number	Supplier	Supplier's ordering code
U5	USBUF02W6		SOTT323-6L	STMicroelectronics	USBUF02W6	STMicroelectronics	USBUF02W6
U6	STM32F103RET7		LQFP-64	STMicroelectronics	STM32F103RET7	STMicroelectronics	STM32F103RET7
U9	LPS001DL		LGA-16	STMicroelectronics	LPS001DL	STMicroelectronics	LPS001DL
U10	LDS3985M33R		SOT23-5L	STMicroelectronics	LDS3985M33R	STMicroelectronics	LDS3985M33R
U11	LSM303DLH		LGA 28L	STMicroelectronics	LSM303DLH	STMicroelectronics	LSM303DLH
U12	LY330ALH		LGA 10	STMicroelectronics	LY330ALH	STMicroelectronics	LY330ALH
U13	LPR430AL		LGA 28L	STMicroelectronics	LPR430AL	STMicroelectronics	LPR430AL
U14	EMIF06-MSD02N16	Micro QFN	STMicroelectronics	EMIF06-MSD02N16	STMicroelectronics	EMIF06-MSD02N16	
U15	LD3985M18R		SOT23-5L	STMicroelectronics	LD3985M18R	STMicroelectronics	LD3985M18R
Y1	Crystal oscillator 32.768 kHz		Citizen	CM130-32.768KDZF-UT	Digi-key	Digi-Key: 300-8633-1-ND	
Y3	Crystal oscillator 8 MHz		MuRata	CSTCE8M00G55-R0	RS Digi-Key Farnell	RS: 283-961 Digi-Key: 490-1195-1-ND Farnell: 1615352	
J9	JTAG (male connector 20-pin 2x10)	THR (spacing 2.54)	Tyco Electronics	2-1634688-0	RS Farnell	473-8282 8395942	
J10	Jumper		THR (spacing 2.54)	Any		Any	
J11	Jumper		THR (spacing 2.54)	Any		Any	

Doc ID 17418 Rev 1

24/27

UM0937

Bill of materials

Table 13. Bill of materials (continued)

Reference	Part / value	Voltage / watt / ampere	Package	Manufacturer	Manufacturer's ordering code / orderable part number	Supplier	Supplier's ordering code
J12	SWD/JTAG (male connector 10-pin 2x5)	THR (spacing 1.27)	SAMTEC	FTSH-105-01-F-D- K	Any		
	JTAG/SWD flat cable		SAMTEC	FFSD-05-D-08.00- 01-N	Any		
	Close jumper			RS	W8030T50RC	RS	251-8575

Revision history

Table 14. Document revision history

Date	Revision	Changes
19-May-2010	1	Initial release.

Please Read Carefully:

Information in this document is provided solely in connection with ST products. STMicroelectronics NV and its subsidiaries ("ST") reserve the right to make changes, corrections, modifications or improvements, to this document, and the products and services described herein at any time, without notice.

All ST products are sold pursuant to ST's terms and conditions of sale.

Purchasers are solely responsible for the choice, selection and use of the ST products and services described herein, and ST assumes no liability whatsoever relating to the choice, selection or use of the ST products and services described herein.

No license, express or implied, by estoppel or otherwise, to any intellectual property rights is granted under this document. If any part of this document refers to any third party products or services it shall not be deemed a license grant by ST for the use of such third party products or services, or any intellectual property contained therein or considered as a warranty covering the use in any manner whatsoever of such third party products or services or any intellectual property contained therein.

UNLESS OTHERWISE SET FORTH IN ST'S TERMS AND CONDITIONS OF SALE ST DISCLAIMS ANY EXPRESS OR IMPLIED WARRANTY WITH RESPECT TO THE USE AND/OR SALE OF ST PRODUCTS INCLUDING WITHOUT LIMITATION IMPLIED WARRANTIES OF MERCHANTABILITY, FITNESS FOR A PARTICULAR PURPOSE (AND THEIR EQUIVALENTS UNDER THE LAWS OF ANY JURISDICTION), OR INFRINGEMENT OF ANY PATENT, COPYRIGHT OR OTHER INTELLECTUAL PROPERTY RIGHT.

UNLESS EXPRESSLY APPROVED IN WRITING BY AN AUTHORIZED ST REPRESENTATIVE, ST PRODUCTS ARE NOT RECOMMENDED, AUTHORIZED OR WARRANTED FOR USE IN MILITARY, AIR CRAFT, SPACE, LIFE SAVING, OR LIFE SUSTAINING APPLICATIONS, NOR IN PRODUCTS OR SYSTEMS WHERE FAILURE OR MALFUNCTION MAY RESULT IN PERSONAL INJURY, DEATH, OR SEVERE PROPERTY OR ENVIRONMENTAL DAMAGE. ST PRODUCTS WHICH ARE NOT SPECIFIED AS "AUTOMOTIVE GRADE" MAY ONLY BE USED IN AUTOMOTIVE APPLICATIONS AT USER'S OWN RISK.

Resale of ST products with provisions different from the statements and/or technical features set forth in this document shall immediately void any warranty granted by ST for the ST product or service described herein and shall not create or extend in any manner whatsoever, any liability of ST.

ST and the ST logo are trademarks or registered trademarks of ST in various countries.

Information in this document supersedes and replaces all information previously supplied.

The ST logo is a registered trademark of STMicroelectronics. All other names are the property of their respective owners.

© 2010 STMicroelectronics - All rights reserved

STMicroelectronics group of companies

Australia - Belgium - Brazil - Canada - China - Czech Republic - Finland - France - Germany - Hong Kong - India - Israel - Italy - Japan - Malaysia - Malta - Morocco - Philippines - Singapore - Spain - Sweden - Switzerland - United Kingdom - United States of America

www.st.com

