

Installer

Please

Read

Instructions

Inside

Air Source Heat Pump Installation and Maintenance Manual

Model Numbers:
RC090-120-140 and 160MHXEA



The outdoor unit (boiler)

Deciding on Where to Install the Outdoor Unit

Choose a location where the noise of the Air to Water Heat Pump when running and the discharged air do not disturb any neighbours.

Install the outdoor unit on a flat, stable surface with plenty of drainage, gravel or grass is ideal; make sure the base can support its weight

Position the outdoor unit so that the air flows into an open area, where there are no plants and animals

If you can see the sea from the position of the outdoor unit you need to apply Blygold, Bronze glow or equivalent anti-corrosion coating on the whole unit.

The unit will not benefit from being mounted on the North or south of the building, any aspect is fine, you should avoid very exposed positions to avoid wind blowing into the back or front of the unit.

The unit needs to be securely mounted at least 100mm off the ground on rubber feet. The unit must be bolted down for security using 10mm bolts and Zebedee bolts. If wall brackets are used we recommend 600mm unistrut cantilever arms are used. Caution should be applied when wall mounting because any vibration from the unit can be transmitted into wall creating noise.

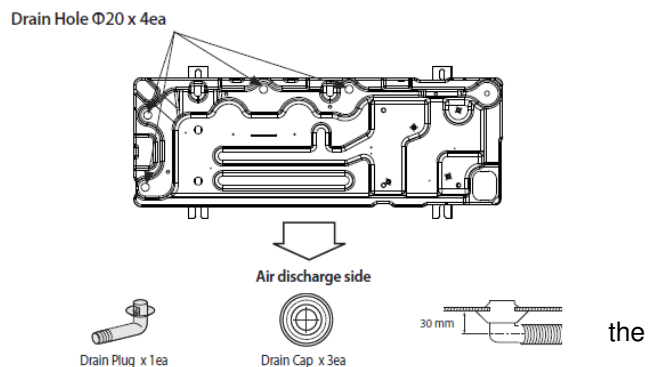

The unit must have adequate drainage away from the unit; it can produce up to 6 L / hour.

There is a drainage kit included which we recommend you don't use, its best to let the unit drain into the ground. If a drip tray is used it must be 25mm longer and wider than the base of the unit to catch all the drips.

Dimensions:

Size 16 - 1420mm (h) 940mm (w) 330mm (d) 103kg

Size 9 - 998mm (h) 940mm (w) 330mm (d) 75kg

The space around the unit is very important, allow: 300mm to the left hand side (facing the front of the unit), 600mm to the right of the unit, 300mm to the rear of the unit and 1500mm to the front of the unit.

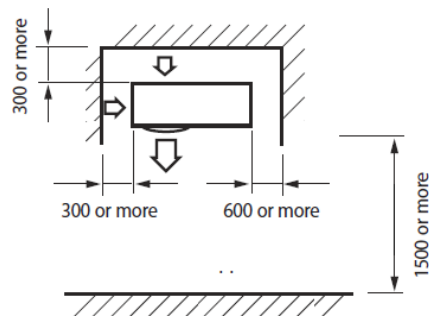

Wooden enclosures are now available for the units, please contact your distributor for details.

The Control Box

When the heat pump is delivered it comes with a control box which also contains the flow switch. Install the control unit indoors as it's not waterproof.

It needs to be sited less than 15m of the hot water cylinder, 10m of the outdoor unit and as near as possible to the pump, flow switch and any zone valves.

The box is 323mm wide, 339mm high, 131mm deep

Pipework Schematic size 9 and 16 units

Standard System With Header Or Buffer And 2 Ports

To keep pump sizes down we recommend 28mm pipework for the main runs

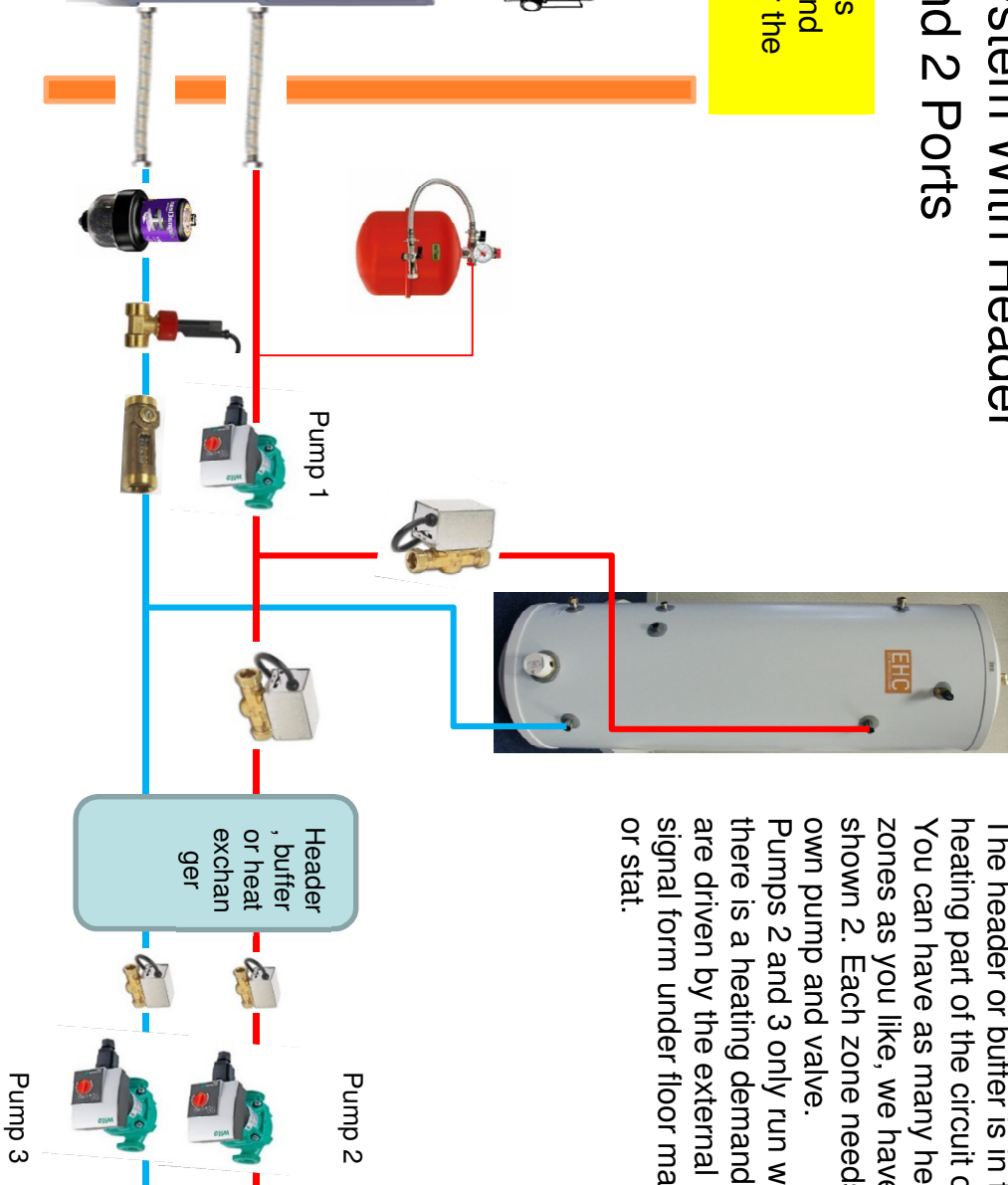
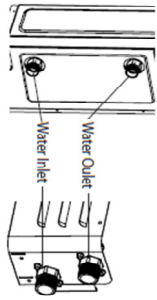

The header or buffer is in the heating part of the circuit only. You can have as many heating zones as you like, we have only shown 2. Each zone needs its own pump and valve. Pumps 2 and 3 only run when there is a heating demand, they are driven by the external run signal from under floor manifold or stat.

The heat pump has 1 inch BSP male connections; these should be connected to flexi hoses. The flexi hoses have to be insulated to conform to MCS.

To maintain flow rate we recommend 28mm pipework is used with this machine. **NEVER use 22mm plastic tube, if you insist on using plastic use 28mm throughout**

You will also need to install:

- High resistance pump,
- Expansion vessel,
- Pressure gauge,
- Pressure relief valve,
- Filling loop,
- Magnetic filter
- Strainer.
- Flow meter
- Flow switch
- 2 x 2 port valves

We recommend the system has a break in it, you can use a header, a buffer or a heat exchanger to do this. This is done to maintain uninterrupted flow.

The domestic hot water cylinder must be manufactured specifically for the heat pump and have a coil with a surface area of 3m² equivalent.

For more details see next page

Other components you need to supply and fit:

An expansion vessel, pressure gauge, pressure relief valve and filling loop

Most heating engineers use a robokit with the appropriate size expansion vessel; this is sized exactly the same way as when using a boiler.



Pump

Your pump needs to supply 20l/min for the 9kW and 30l/min for the 16kW unit. The static resistance through the unit is 10kPa for the 9kW and 15kPa for the 16kW unit. The flow meter has a resistance of around 5kPa

The cylinders (Gledhill) have a static resistance of 5kPa for the heat pump coil and 19kPa for the solar coil.

The total resistance of the components will be approximately 39kPa for the size 9 unit and if the cylinder is piped using both coils and approximately 44kPa for the size 16 unit.



Flow switch and flow meter

The unit requires 17L / min flow at all times, if you don't achieve this E911 error will occur to check this flow switch is installed. The flow switch comes with the control box.



The flow Switch **MUST** be installed in either horizontally or vertically with at least 150mm of straight pipe either side, connection is 1" female BSP. The wire is 2m long and needs to connect into the wiring station. This wire can be extended to suit. We recommend a flow meter is installed into the flow side of the flow switch as per the photo. Adaptors may be required to enable this join. The flow switch is not IP65 rated (weatherproof) and so must not be installed externally.

Diverter valves

If you require domestic hot water and heating, diverter valves are required, you need to supply these.



Water Filter

In all cases a filter with strainer needs to be installed in the return to the heat pump. A magnetic filter **must** also be installed in the return to the unit. The filters ensure that debris/foreign materials do not cause damage to the heat exchanger in the unit voiding warranties.

Glycol

A propylene glycol mixture must be utilized to prevent freezing of the water within the system. It is important that the glycol concentration is adequate to protect the unit in case of power failure in very cold conditions. If the unit freezes up there will be no warranty. Manufacturer dependant, a mix of around 25% should suffice.

Buffer vessels, heat exchangers and low loss headers

You don't have to use a buffer vessel on a Samsung but we do need a minimum flow rate of 17l/min and have a circulating volume of over 20 Litre. To achieve this is much easier if you break the system in two with a header, a buffer or a heat exchanger.

Bypass Valve

If you don't use a header buffer or heat exchanger you must install a bypass valve in the heating circuit as far away from the heat pump as possible. The bypass valve enables flow to be maintained as the trv's shut down at all times to prevent unit flow fault.



The Cylinder:

The cylinder needs to be installed less than 15m from the control box to allow for the temperature sensor cable. Note the size and weight of the cylinder. Full installation instructions are included with the cylinder.

Cylinders can be used IF the coil area is more than 2.5m². Smaller coils are not acceptable and cannot be used. Please do not attempt to utilize a standard central heating, non-heat pump optimized cylinder. Cylinders can be pressurised or open vented.

Wiring diagram for heating and HW heat pump:

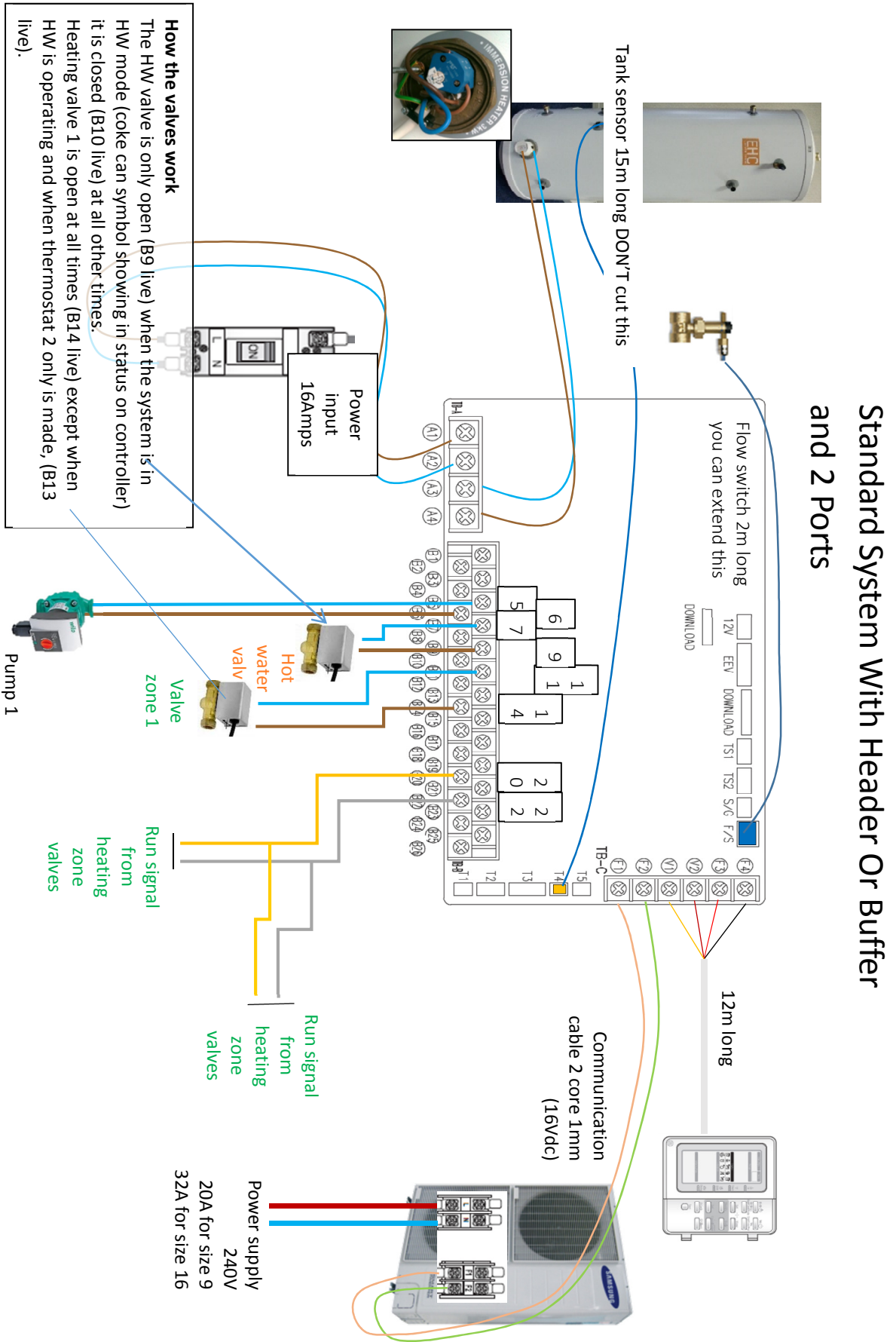

Stats and heating wiring

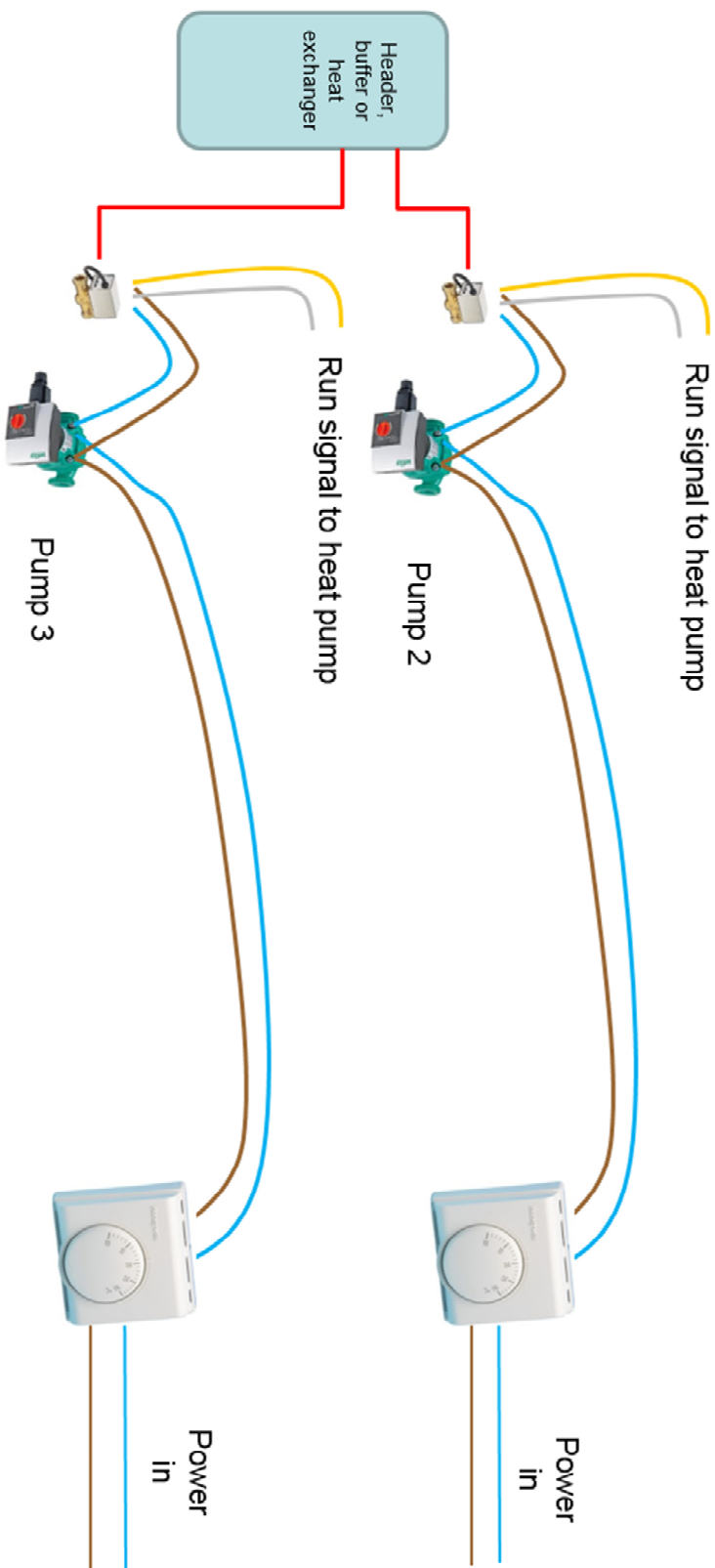

If under floor heating is used the stat is replaced with the boiler run signal in the manifold

Wiring and Power Supply Information:

Power

The EHS system needs 2 power supplies:

One connects into the outdoor unit, 20 Amp for the 9kW and 32 Amp for the size 16

The one for the control box is 16 Amp and wires into the top of the breaker (mcb) in the box

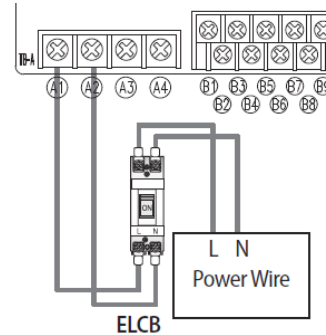

Immersion Heater

The immersion heater is connected into the control box terminals A3 Neutral and A4 Live, The control box controls the operation of the immersion heater. If a fused spur is used it must be labelled as switching it off will cause an error.

Communication cable

must be run from the outdoor unit to the control box. Use 2 core flex 0.5-1mm (its 16V ac)

Sensors

The **blue cylinder sensor** plugs into a socket T4 on the controller PCB and into the control sensor pocket in the cylinder in the top ½ of the cylinder. **Must be above immersion**. The cylinder sensor needs to go 115mm into the cylinder; it must be clipped so it can't pull out.



The **red safety sensor** is to avoid over temperature, If no backup boiler is used the sensor is not needed. It plugs into a red socket T3 on the controller PCB and must be fixed to the flow pipe of the heat pump.

Using two port valves

2 port valve for Hot water, wire brown wire to B9 and Blue to B7, the rest are not used.

2 port valve for heating zone 1 wire B14 live and B11 Neutral

Thermostats/ timers and under floor heating manifolds

We recommend in all cases the heating should be controlled by an external field supplied room stat / setback stat, time clock or a run signal from a boiler enable signal from under floor manifolds.

The heat pump needs a run signal by making a connection from B20 – B22, B20 is permanently live 240V ac.

When the stat is made the unit will run, when the stat opens the unit will stop. **NOTE the pump will run on for 6 minutes after the unit is told to stop.** Hot water production is not affected and will always take priority.

Pump

The circulation pump must be wired Live to B6 and neutral to B5, MAX pump power is 500 Watts. If two pumps are used wire them both to these terminals

Start Up Procedure:

Checklist

Outdoor unit:

- Is there 300mm to the left of the outdoor unit?
- Is there 600mm to the right of the outdoor unit?
- Is there 300mm to the rear of the outdoor unit?
- Is there 1500mm at the front of the outdoor unit?
- Is the unit more than 100mm above the ground?
- Have you allowed for the unit drainage?
- Is there a power supply to the outdoor unit?

Indoor control box

- Have you stuck the yellow sticker (attached) to the front of the unit?
- Is there a separate supply for the indoor control box
- Have you wired in a room thermostat? OR a run signal from u/floor manifold
- Is the Samsung remote controller well out of reach of the end user?

The plumbing:

- Is plastic pipe being used? If so is it all bigger than 22mm?
- Is a flow meter installed directly into the flow switch?
- Is the flow switch horizontal?
- Is there 150mm of straight pipe either side of the flow switch?
- Is the cylinder sensor plugged in 2/3 of the way up the cylinder?
- If the pump is a variable speed type is it set to meet max speed within 10 seconds?
- Is there a filter before the return to the heat pump?
- Have you installed a bypass valve or allowed for bypass?
- Have you got your glycol ready to put in the unit?
- Have you lagged all external pipework?

Start-up Procedure:

Filling and flushing:

When installing any Heat pump **we insist on** a thorough system flush prior to connection in line with the Building Regulations for England and Wales, Part L, 2006.

Using the power flusher fill the system with water and 25% Propylene Glycol to more than 1 bar.

With the power **OFF**, remove the front of the remote controller by sliding it upwards, turn it over and hold the red sensor at the top. **DON'T TOUCH THE PCB**, there are 8 dip switches near the red sensor, using a small screwdriver flick dip switch **1 and 5** to on. Cooling will no longer be available. Put the controller back on the wall.



Setting up the cylinder immersion heater

The immersion heater has its own stat; this **MUST** be set to 70C. This is to avoid the immersion heater cutting out before the legionella function is complete



Powering Up

Makes sure all your room thermostats are off and all underfloor run signals are off first.

Apply power to indoor control box first then the outdoor unit.

At the indoor unit In the middle of the control box PCB you will see two tiny leds one red and one orange/green flashing. If this doesn't happen check there is power on at the outdoor unit. Check the comms cable between the outdoor unit and the control box F1 and F2.

Setting the Clock

Press the grey set button for 5 seconds.

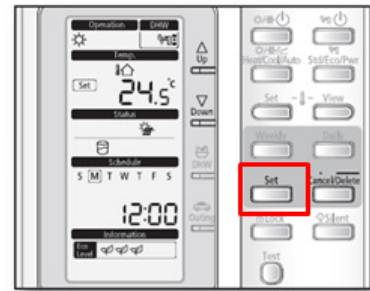

The day will flash, adjust this with the silver up and down buttons, press grey set.



The hours will flash adjust this with the silver up and down buttons, press grey set.



The minutes will flash, adjust this with the silver up and down buttons, press grey set you are back to the normal screen.



Field Settings

Field settings are what define how the unit is configured and how it will work, each system can have very different field settings.

Many field settings will need to be made: NOTE the set button is the grey one not the blue

Field settings are in groups the 20s are for weather compensation and temperature control in heating, the 30s are for the cylinder and the 40s are for backup boilers and hybrid systems. Below are the field setting specific to your system as described in this book.

Enter field settings by pressing **test** for 6 seconds, 10 will show on the screen

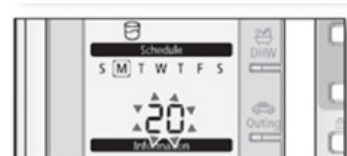

Scroll up to 20 using the silver up button, press **set**, 2011 will show.

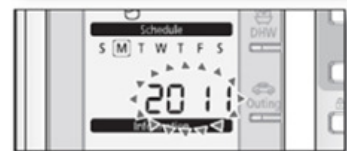

To adjust this setting press **set** again the setting will appear at the top of the screen, adjust it with the silver up down buttons and press **set** again, scroll up to the next field setting using the up and down buttons and repeat.

When you have finished all your 20 settings press **cancel delete** once, 20 will show on the screen, press the silver up button to move to the 30s and repeat the procedure above.

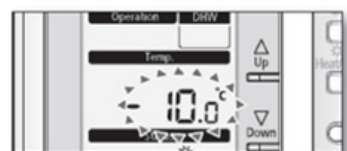

When finished or if you get lost press cancel delete 2 x to return to the normal screen

Note: if you set a field setting and go back to check it, it will not have changed, the field setting do not get written to the PCB until you finish setting and exit.

Field settings to set, see user manual for a full list

2011	-2	low ambient setting for optimisation set to -5 in Scotland
2012	+15	high ambient temp for optimisation
2021	45C	for u floor 50C for rads flow temperature in cold weather
2022	37C	flow temperature in mild weather
2091	1	tells unit to look for a run signal on terminal B22
3011	1	tells unit it has a cylinder connected
3025	Max cylinder heating time, 50mins for 200ltr, 90mins for 300ltr	
3032	Delay time before immersion heater starts, 30mins for 200ltr, 60mins for 300ltr	
3042	W	Wednesday day legionella happens (always use Wednesday) #
3043	3am	time it happens
3044	60C	legionella temp

it is possible to scroll through the days & select every day, then legionella can be run daily rather than weekly.

Cylinder timer

To avoid the cylinder heating being switched off we always add 2 on timers a day, one at 3-00 am and one at 15-00 pm. To insure the cylinder is hot 24 hours a day we don't normally set any off times.

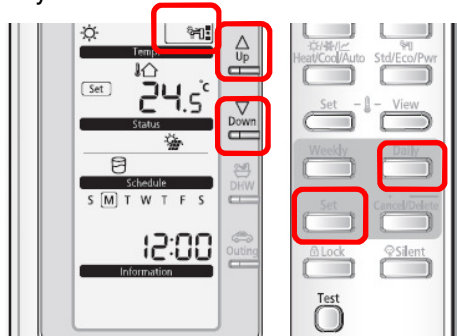

Press **daily** button once, no 1 and on shows, press **grey set**, press up or down until the tap symbol shows at the top of the screen with 2 dots **press grey set**, adjust hours with up or down button to 3 am press **grey set**, minutes flash press set. Now everything flashes press set (grey). No 2 appears do the same again but for 15-00. After everything is set no 3 will show. Press **cancel delete** twice, the normal screen will show. Daily will appear next to the time. The timer is active.

To **delete the timers** press daily 2 x the set schedule will show, press and hold cancel delete for 5 seconds, keep doing this until no1 shows, press cancel delete 2 x and in the normal screen daily will have disappeared.

Electrically testing the unit:

It is possible to test each component one after another using a service function. You can use this to make sure you have wired everything correctly.

To access service mode press **blue set** button **and test** button together for 6 seconds.

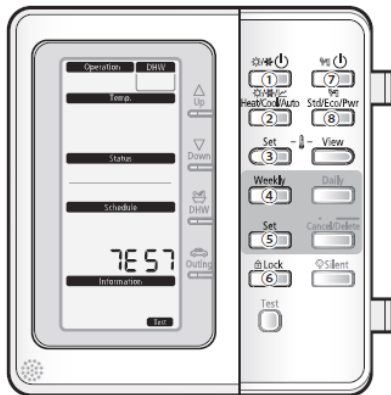

The controller will display TEST. Immediately press the top left button to turn the pump on and leave it running while in test mode to avoid a fault.

Press the **top left** button the unit will run the pump.

Press **weekly** to test the immersion heater in the hot water cylinder.

The hot water valve should be closed, Press the **lock** button to make a coke can appear the HW valve should move to open, press lock again to close it.

The Heating valve will be open, Press the **top right** button to close it. 2-1 will show on the screen, Press top right to open it again.

To test the external run signal or stat is connected adjust temperature on stat up.

Heat1 will replace test on screen.

Using the **blue view** button you can see 5 temperature sensors, inlet and outlet to the heat exchanger, the red sensor (where used), water cylinder and sensor in the remote controller.

To exit service mode press and hold **cancel delete** for 6 seconds

Set Test	(3sec) Enter Self Test Mode	7E57
Cancel/Delete	Function OFF / (3sec) Quit Self Test Mode	-
①	Water Pump	
②	Back up Heater 1 st state	
③	Back up Heater 2 nd state	
④	Booster Heater	
⑤	Back up Boiler	
⑥	DHW Valve	
⑦	Zone #1 Valve	2-1
⑧	Zone #2 Valve	2-2
View	Show five temp. sensor values in order	
-	Not available	
-	Thermostat (Heating) No.1 / No.2	
-	Thermostat (Cooling) No.1 / No.2	

Test 1 To Avoid further problems we recommend you set the units up in test mode before starting the heat pump.

Firstly in test mode run the pump, press **blue set** button **and test** button together for 6 seconds. The controller will display TEST. Immediately press the top left button to turn the pump on and leave it running while in test mode. When the pump is running a little house with a circle around it in the status window of the controller.

The unit wants to see at least 17 l / min flow to activate the flow switch, if there is not enough flow the unit will never operate. You should have a flow meter installed, if you haven't now is the time to buy one.

If you look into the flow meter you can see the flow in litres per minute. In this picture you can see a flow rate indicated, this shows 25l/min NOT 35l/min



If the flow rate is too low you need to fix this before moving on. See problems page 17

Once the flow rate is high enough move onto test 2 below (while still in test mode)

Test 2 if you don't have a header, heat exchanger or buffer

Set up the bypass valve with radiators

In heating mode check the unit is pushing water into the radiators only. Open the bypass valve fully, if you are not sure set it to its lowest setting. Now close every radiator on the system except one. Using the flow meter check the flow rate is above 16/l to avoid faults. Adjust the bypass valve to achieve this. The bypass is set now open the rads again.

To exit service mode press and hold **cancel delete** for 6 seconds

Set up the bypass valve with U floor heating

In heating mode check the unit is pushing water into the under floor heating circuit only. Open the bypass valve fully, if you are not sure set it to its lowest setting. Using the flow meter check the flow rate is above 16/l to avoid faults. Adjust the bypass valve to achieve this. The bypass is set now turn up the wall stats again.

To exit service mode press and hold **cancel delete** for 6 seconds

Starting it up in heating mode:

Turn up your thermostats to send a run signal to the unit, the pump will start immediately, a little house with a circle round it appears in the status window, when the compressor starts after 3 minutes, you will see the symbol for the compressor in the status screen. Its a little milk churn with a c in it.

The pipework will begin to heat up, check the flow temperature by pressing blue view button once, the temp of the flow is shown next to a symbol of a house in a circle. Over time this will warm up, now check all the radiators or U floor loops are hot as well.

If the unit doesn't start see problems page 16 and 17

Starting the System in hot water mode

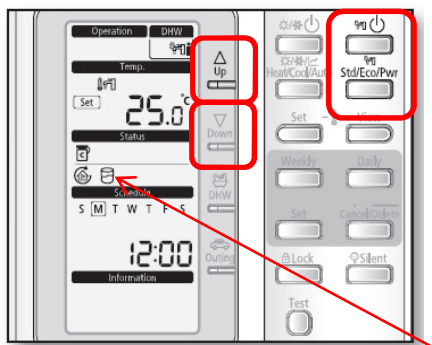

Press Hot water on off button to start the unit, top right button.

Set the desired temperature to 48C press blue set button once until a tap shows now set using the up and down buttons.

The unit will take up to 6 minutes to start in Hot water mode, be patient don't press buttons. When the unit is heating the cylinder this coke can symbol shows on the controller.

Run test in hot water mode

In hot water mode check that the 2 ports are sending water into the hot water cylinder, Using the view button (blue) on the remote controller check the hot water cylinder temperature and note it down, the hot water temperature is displayed when the tap symbol shows.

After 15 minutes of running check the hot water temperature again, it should have risen, again note the temperature. If the temperature has not risen check the blue temperature sensors is installed properly. If the unit is running well it should heat the cylinder to 48C without needing the immersion heater

Performance testing

With the unit running flat out measure the air temperature as it enters the back of the unit and the ambient temperature well away from the unit? They need to be the same for the unit to operate properly. Note these on the commissioning report

Not enough hot water.

The Water storage temperature is lower (48C) than a normal fossil fuel cylinder. It's important to check that any shower or bath mixers do not further reduce the water temperature. Using your thermometer check that the hot water comes out the tap at the same temperature it leaves the cylinder. If it doesn't you might need to make adjustments to taps mixers etc. DON'T raise the cylinder temperature to compensate.

Problems:

If there is a problem with flow no error shows for 10 minutes, it's waiting for the air to come out the system.

E911 and compressor not running, E911 means the water is not moving fast enough to push the paddle switch.

If you look into the flow meter you can see the flow in litres per minute. In this picture you can see a flow rate indicated, this shows 25l/min NOT 35l/min

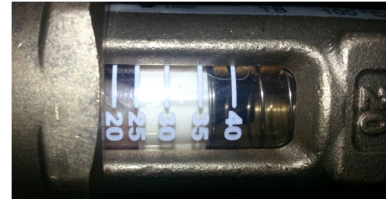

The flow switch trips out at 15l/min, if the flow drops below this E911 shows.

Check:

The flow rate **MUST** be over 17l/min

The flow switch is connected to the PCB of the control box

The flow switch is round the right way, you can turn the head,

All valves are open.

The pump speed is set at highest

There is no air in the system

There is water in the system



If you manually open the hot water 2 way valve check the flow rate again, if you can only reach 16l with the heating and hot water open together it's a sure sign the pump you have installed is too small.

If you think the flow switch is faulty, (it very rarely is) remove the paddle from the water by undoing the red nut, you will need to block up the hole temporarily. Now run the pump again switch your stats down then up again. **After 3 mins of pump operation and holding the flow switch the outdoor unit will start, don't rush the system it takes time**

Rattling flow switch / Cavitation

E911 fault could be caused by a rattling flow switch. This can usually be heard but can also be felt by holding the flow switch. To correct it use a screwdriver or pliers on the top of the Flow meter and turn the ball-o-fix valve from 12 o'clock to 1 o'clock; this deflects the water flow & should further reduce the rattle.

Flow meter in standard positioning:



Flow meter in 1 o'clock positioning:

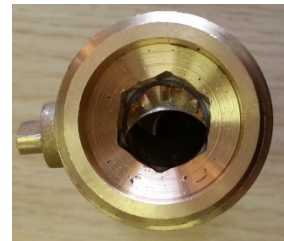
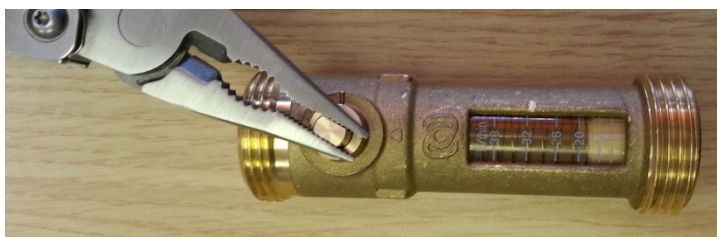

Caution in Cold weather

If the water in the system is below 10C the heat pump WILL NOT START.

Press the blue view button, you can see 4 sensor readings, press it until the pump symbol shows (a circle round a house). This is the water temperature, if it's below 10C the unit will not start but the pump will run.

You must warm up the water to get the unit to run, the easiest way to do this is to run the immersion in Test mode (page 13) to warm up the cylinder first, by manually cranking open the HW valve you can prime the heat pump with the warm water coming back from the cylinder.

If everything is cold less than 5C (the remote controller, the water, the tank etc.) the unit will not operate correctly, it can't understand how the house has got so cold. You will find the on off button for heating won't work and if you try to use HW mode it will switch itself off. You need to allow the unit to warm up first. Make sure the remote controller is in a heated room.

Warranty Registration Card

Warranty MUST be registered within 30 days of delivery to site. You must send proof of delivery with the warranty card.

Warranty will start from the date the unit is delivered.

All registrations made more than 30 days after this period will be rejected.

If commissioning data is not available at this time register the unit and send the data at a later date, the warranty certificate will be returned to you when the whole form is completed.

This warranty covers only the Samsung components of the installation, it is parts with a pre-set labour allowance only. The warranty is between Freedom Heat pumps and the installation company only, this is NOT an end user warranty.

It is the role of the installer to offer a warranty to the end user covering all of the heating system including the heat pump.

The standard warranty is valid for 12 months from date of delivery as entered on this card. If the unit is installed by a Samsung approved installer **and** this card is sent back within 30 days of delivery date the warranty is automatically extended to 36 months.

Approved installers also have access to warranty extensions at the time of registration for warranty; a 4 year extension to the warranty can be purchased from your distributor or directly from Freedom Heat Pumps.

Call 02380274833 for details and pricing

The warranty card can also be used as a maintenance card.

Please return a photo or scan of this form and the delivery note to warranty@freedomhp.co.uk Once received we will confirm receipt and start of the warranty period.

Samsung EHS commissioning and maintenance sheet

You will need a thermometer and a pen to complete this form:

The Unit		
Model Number		From outdoor unit right hand side
Serial Number		From outdoor unit right hand side
Ambient air temp		measure this in the garden
Have you cleaned the filter		
Glycol concentration %		measure this
Have you cleaned the coil		
Have you polished the unit?		
In Heating Mode		
Water flow temp		from remote controller
Water return temp		measure this
Flow rate l/min		from flow meter
Temp of air at the back of the unit		from remote controller
Flow rate l/min when radiators and ufloor manifolds closed		from flow meter
Cylinder		
Hot water cylinder model and serial no		
Cylinder water temp at start up		press view button on rc
And after 30 mins		press view button on rc
Water flow temp		from remote controller
Water return temp		measure this
Flow rate l/min		from flow meter
Immersion heater current		press immersion button on rc
Immersion heater cutout setting		remove cover and adjust to 70C
Commissioning Data not required at maintenance		
Where was the unit purchased		
Date Installed		
Date delivered proof of delivery required		warranty starts from this date
Date Commissioned		
Are you a Samsung approved installer?		
Would you like to be an approved installer?		
Warranty required years	3 / 5 / 7 years	
Installation Address		
You		
Engineers name		
Company		
Address		
Engineers phone number		
Email address		
Signature of engineer		
Date		

I accept the terms of the Samsung warranty and confirm the system has been registered within 30 days of delivery. I also include a copy of the delivery note.

Signed

Name

Maintenance Monobloc Systems

The Samsung heat pump should be maintained at least once a year to comply with warranty and RHI. The warranty card also doubles up as a maintenance sheet.

Maintenance procedure

Stop the unit, clean the strainer or magnetic filter in accordance with manufacturer's recommendations and replace it.

Test the concentration of the Anti-freeze (glycol) in the system using a Glycol tester the level should be 25%. If you don't have a glycol tester a glycol tester / refractometer can be bought from your heat pump supplier or online.

Refill the unit, pressure should be 1 -2 bar,

We need to **test the operation of the unit** against the hot water cylinder. So first we need to draw off 50 liters of water, run a couple of taps for 5 mins to achieve this. The unit should start up automatically in hot water mode, if it doesn't press the top right button on the controller, in 3-4 mins it will start heating the cylinder, a coke can symbol will show in the status section of the remote controller.

The heat pump should be able to achieve 48C cylinder temperature without using the immersion heater.

While running, check the outdoor unit for damage & debris, the coil needs washing, we recommend you use an approved EHS heat pump cleaning chemical, your distributor will stock this. Instructions are given on the bottle. You also need to clean and polish the outside casing we recommend car wax to do this.

Hot water Cylinder:

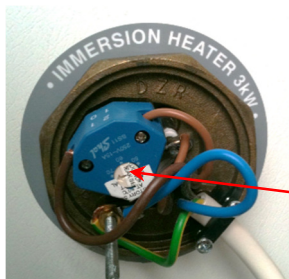

Check electrical connections & sensor are fixed properly and the overheat thermostat is set to 70C.

Overheat Thermostat
Adjustment

Press the silver immersion button on the Samsung remote controller; this will force the immersion heater on. Check immersion heater works properly, Measure the current drawn by the heater; it should be 12-13 Amps.

Measure the temperature of the flow using the remote controller.

Measure the flow rate from the flow meter.

With the unit running flat out measure the temperature of the air as it enters the coil and the temperature of the air in the garden. They should be the same check cold air is not recirculating.

Explaining the Operation of the System to the end user

You have now set the unit up to run from an external signal Using a field supplied room thermostat or signal from an under floor heating system through B20-B22 and/or B20-B24; the controller no longer drives the unit.

When the contact is made the unit will start and the water temperature will be controlled by the heat pump, you will not have any control over it. The water temperature is determined by the outdoor temperature; the colder it is outside the warmer the water. The unit is running in weather comp mode,

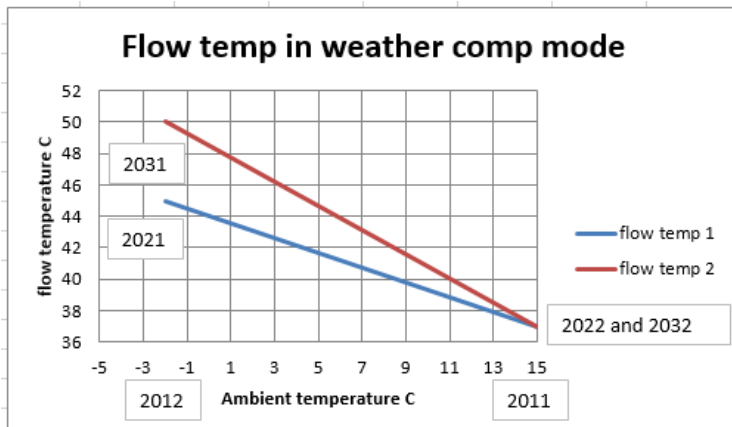

You will see 0.0C on the screen; the unit is using weather compensation function to work out the water temperature. If you need to boost the heating water temp this can be done by pressing the silver up and down buttons. This boosts the radiators by up to +5 C but warning this will cost more money to run.

When an external stat or run signal is used most of the

functions of the Samsung remote are disabled. A waging finger shows at the bottom to show this.

All these buttons are disabled and the functions they control are also disabled

Note: when the heating command is sent to the unit it will not start for 3 minutes. And when the thermostat or signal is removed the pump will run on for up to 6 minutes.

On latest software the end user can override the stat switching the unit off with the top left button. Avoid this as the unit will no longer run. If the sun signal is not on the display the heating is not going to operate.

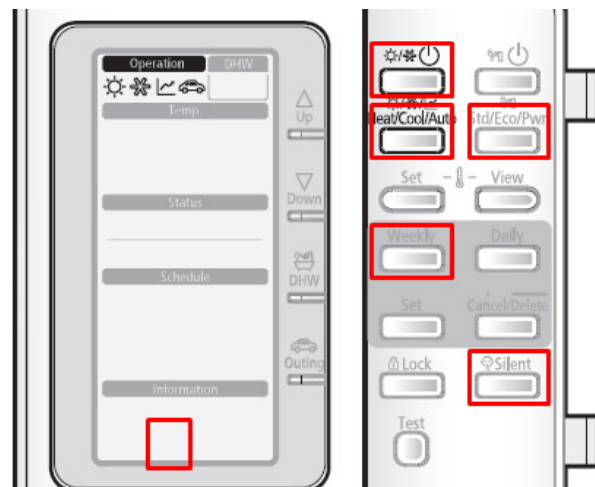

How hot water works

The hot water cylinder has priority over the heating, if the cylinder temperature falls 5 degrees below its set point the unit will automatically switch to heating the cylinder. Once set temperature is achieved the unit will go back to heating the house.

The hot water cylinder loses almost no heat (1/3 a degree an hour) if no hot water is used. The hot water cylinder takes less than an hour to heat up from cold. If you need hot water very fast the DHW button forces the unit to heat the water flat out, the unit will stay in this mode until you press the DHW button again

To protect from legionella the cylinder is heated to 60 degrees C once a week automatically.

Leave this page with the Homeowner

Your Samsung heat pump heats the house and hot water cylinder much like a normal fossil fuel boiler however there are a couple of differences which you should notice.

- 1 The radiator temperatures are lower than normal and will alter as the outdoor temperature changes. The colder it is outside the warmer the rads and vice versa. This function is automatic and is designed to save you money. At their hottest they will reach 50C. If you would like a constant radiator temperature this can be set by an engineer but it will increase your run costs by up to 25%.
- 2 The system is designed to run continuously in cold weather, turning the system on and off will make the house uncomfortable and will increase your run costs. The most efficient way to run this heating system is to leave it running at the set temperature 24 hours a day in winter time. If you turn off the heating and let the house get cold (less than 17C) it will take a very long time to warm back up to a sensible temperature.

Your systems have been set up to be simple to operate.

The Samsung controller looks like this, you should not use this or press the buttons on it, it is for commissioning and making settings to the system only.



You should see 0.0C on the screen this means the unit is under external control from a room thermostat.

If the system goes into fault, the screen will show a number at the bottom starting with E, for example E911 – A00
The engineer will want to know this number when you call him.

Heating

Control of the heating is by your wall mounted thermostat, not the Samsung controller; you need to read the instructions for this thermostat as its field supplied. The boiler will run when told to by the thermostat. DON'T set the room temperature too low, the heat pump takes time to recover the house temperature, as a rule don't set the temperature more than 2 degrees below your normal set temperature when you go out of the house or it will take a long time to recover.

To switch off the heating in summer set the temperature down to 16C to avoid the heating starting up.

To control the temperature in your rooms please use the radiator valves.

Hot water

Your system will keep the hot water cylinder hot at all times automatically, as you use the water the heat pump will constantly top up the cylinder. A cold cylinder should be reheated within an hour. An anti-legionella operation will be completed at a predetermined time every Tuesday morning. The hot water will be hotter on a Tuesday morning than the rest of the week.

Warranty Important

Attached to this document is a warranty page **your installer must** fill it in and return it to activate the warranty. No claim will be processed without this paperwork being returned. Your installer will offer you some warranty packages to cover your installation and their own work.