

# PROFITEST 0100S-II+

Tester DIN VDE 0100

3-348-889-03

14/2.10



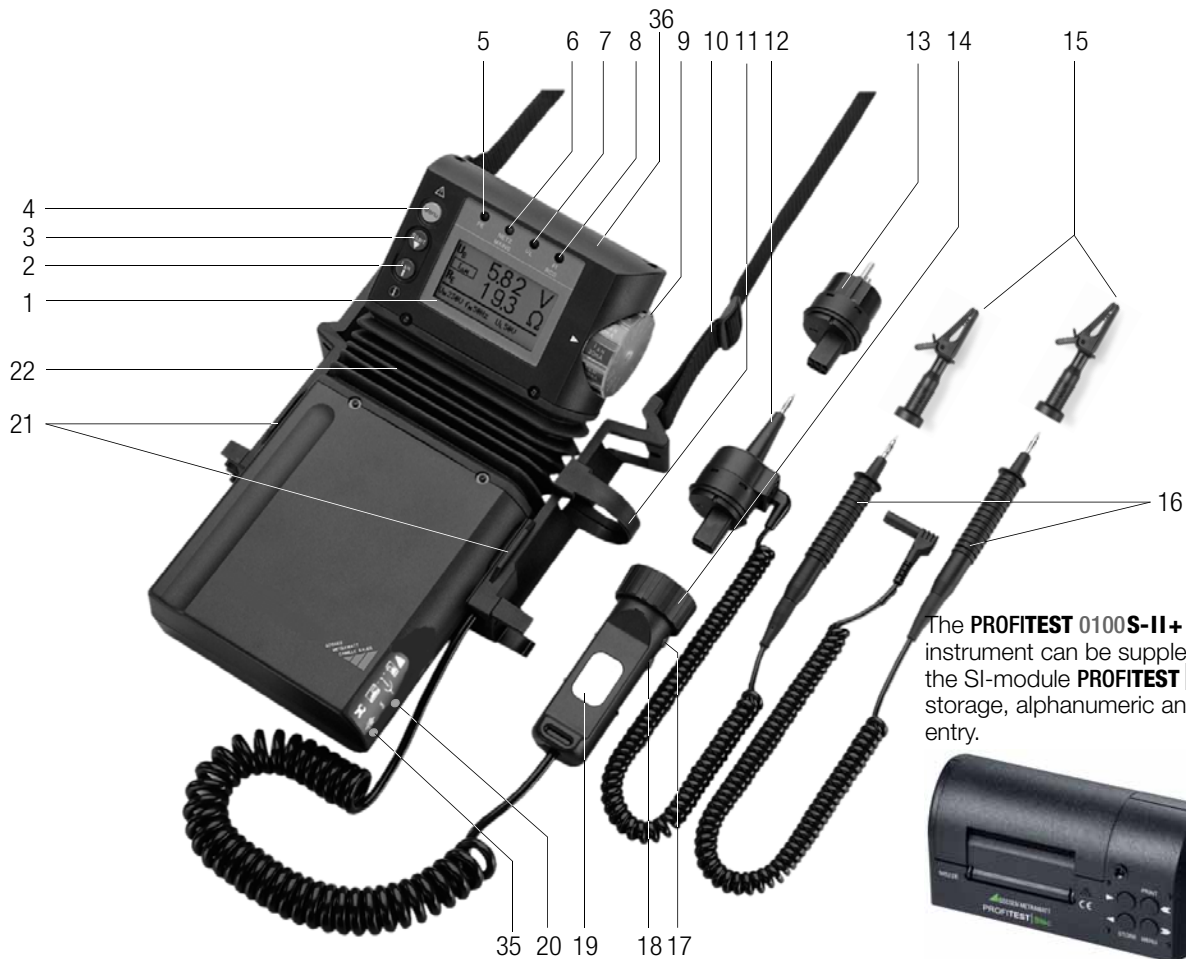

The **PROFITEST 0100S-II+** test instrument can be supplemented by the SI-module **PROFITEST | SI-BC** for storage, alphanumeric and barcode entry.



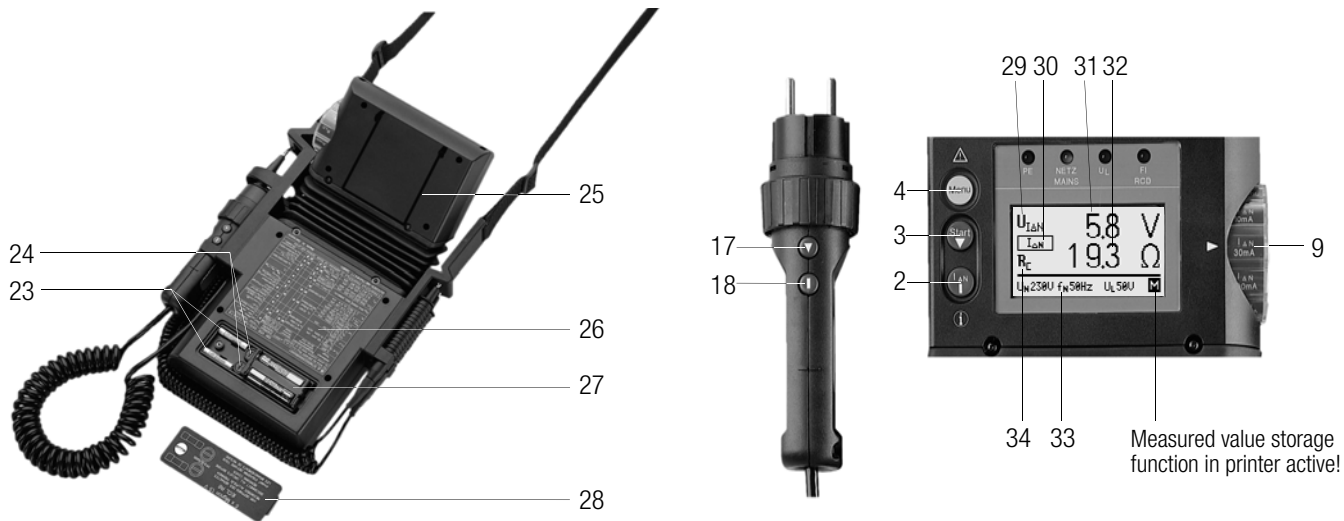

- |                            |                                   |   |  |
|----------------------------|-----------------------------------|---|--|
| 1 LC Display Field         | 12 Measuring Adapter (2-pole)     | 21 Strap Eyelets                          | 31 Three Place Numeric Display: Measurement Value 1 with Unit of Measure |
| 2 $I_{\Delta N}$ / i Key   | 13 Plug Insert (country specific) | 22 Swivel Hinge                           | 32 Three Place Numeric Display: Measurement Value 2 with Unit of Measure |
| 3 Start Key ▼              | 14 Test Plug (with retainer ring) | 23 Replacement Fuses                      | 33 Abbreviation for Selected Sub-Function, Messages and Help             |
| 4 Menu Key                 | 15 Alligator Clip (plug-on)       | 24 Fuses                                  | 34 Measurement Value 2, Abbreviated                                      |
| 5 PE Lamp                  | 16 Test Probes                    | 25 Fold-Out Stand                         | 35 Charging Socket / Current Transformer Connector Jack                  |
| 6 NETZ/MAINS Lamp          | 17 Start Key ▼                    | 26 Serial Plate                           | 36 Infrared Interface  |
| 7 $U_L/R_L$ Lamp           | 18 Key I                          | 27 Battery Holder                         |  |
| 8 FI/RCD Lamp              | 19 Contact Surfaces               | 28 Battery Compartment Lid                |  |
| 9 Function Selector Switch | 20 Probe Connector Socket         | 29 Measurement Value 1, Abbreviated       |  |
| 10 Shoulder Strap          |                                   | 30 Abbreviation for Selected Sub-Function |  |
| 11 Test Plug Holder        |                                   |   |  |

Contents	Page	Contents	Page
<b>1 Applications</b>	<b>6</b>	7.2.2 Testing RCCBs with 5 • I <sub>DN</sub> (10 mA- and 30 mA)	27
<b>2 Safety Features and Precautions</b>	<b>7</b>	7.2.3 Testing of RCCBs which are Suited for Pulsating DC Residual Current	28
<b>3 Initial Start-Up</b>	<b>8</b>	7.3 Testing for Special RCDs	29
3.1 Installing or Replacing Batteries	8	7.3.1 Systems with Selective RCDs	29
3.2 Selecting a Language, Basic Function and Sub-Function Settings	8	7.3.2 PRCDs with Non-Linear Elements	30
3.3 Battery Test	9	7.3.3 SRCDs, PRCDs (SCHUKOMAT, SIDOS or comparable)	32
3.4 Recharging the Batteries	10	7.3.4 Type G RCCBs	33
3.5 Downloading a Software Update, Managing Report Data	10	7.4 Testing with Adjustable Residual Current	34
<b>4 Abbreviated Instructions for Quick Initial Start-Up</b>	<b>14</b>	7.5 Testing RCDs in IT Systems	34
<b>5 General Instructions</b>	<b>16</b>	7.6 Testing Residual Current Circuit Breakers in TN-S Systems	36
5.1 Connecting the Instrument	16	<b>8 Testing of Breaking Requirements for Overcurrent Protective Devices, Measurement of Loop Impedance and Determination of Short-Circuit Current (functions Z<sub>Loop</sub> and I<sub>k</sub>)</b>	<b>37</b>
5.2 Automatic Settings, Monitoring and Shut-Off	16	8.1 Measurement with Positive or Negative Half-Waves	38
5.3 Measurement Value Display and Memory	17	8.2 Evaluation of Measurement Values	39
5.4 Testing Earthing Contact Sockets for Correct Connection	17	8.3 Loop Impedance Measurement	39
5.5 Help Function	18	– Measurement via and without tripping the RCCB	39
<b>6 Measuring Alternating Voltage and Frequency</b>	<b>18</b>	8.4 Testing Meter Start-Up with the Adapter	40
6.1 Voltage between L and N (U <sub>L-N</sub> )	18	<b>9 Measuring Supply Impedance (function Z<sub>j</sub>)</b>	<b>41</b>
6.2 Voltage between L and PE, N and PE, as well as L and N	19	9.1 Testing Meter Start-Up with Earthing Contact Adapter	42
6.3 Voltage between the Probe and PE (U <sub>S-PE</sub> )	20	<b>10 Earthing Resistance Measurement (function R<sub>E</sub>)</b>	<b>43</b>
6.4 Measuring Current with a Clip-On Current Transformer	20	10.1 Measuring with Probe	44
6.5 Z541A Temperature and Humidity Measuring Adapter	22	10.1.1 Automatic Measuring Range Selection	44
<b>7 Testing RCDs</b>	<b>23</b>	10.1.2 Manual Measuring Range Selection	44
7.1 Measuring Contact Voltage (with reference to nominal residual current) with 1/3 Nominal Residual Current and Tripping Test with Nominal Residual Current	23	10.2 Measuring without Probe	45
7.2 Special Testing for Systems and RCCBs	26	10.3 Evaluation of Measurement Values	45
7.2.1 Testing for Systems and RCCBs with Rising Residual Current	26	10.4 Measuring Earth Electrode Potential (function U <sub>E</sub> )	46

Contents	Page	Contents	Page
<b>11</b>		<b>18.1</b>	<b>Table 1</b> ..... 71
<b>Measuring the Impedance of Insulating Floors and Walls (Standing Surface Insulation Impedance <math>Z_{ST}</math>)</b> .....	<b>47</b>	<b>18.2</b>	<b>Table 2</b> ..... 71
<b>12</b>		<b>18.3</b>	<b>Table 3</b> ..... 72
<b>Measuring Insulation Resistance (Function <math>R_{ISO}</math>)</b> .....	<b>48</b>	<b>18.4</b>	<b>Table 4</b> ..... 72
12.1 Measuring Earth Leakage Resistance (function $RE_{(ISO)}$ ) .....	50	<b>18.5</b>	<b>Table 5</b> ..... 72
12.2 Insulation Measurement with Selectable Test Voltage .....	50	<b>18.6</b>	<b>Table 6</b> ..... 73
12.3 Insulation Measurement with Rising Test Voltage .....	51	<b>18.7</b>	<b>List of Abbreviations and their Meanings</b> ..... 74
12.4 Evaluation of Measurement Values .....	51	<b>19</b>	<b>Repair and Replacement Parts Service Calibration Center and Rental Instrument Service</b> ..... <b>75</b>
12.5 Setting the Limit Value .....	51	<b>20</b>	<b>Recalibration Service</b> ..... <b>75</b>
<b>13</b>		<b>21</b>	<b>Product Support</b> ..... <b>75</b>
<b>Measuring Low-Value Resistance of up to 100 <math>\Omega</math> (protective conductor and bonding conductor)</b> .....	<b>52</b>		<b>PC software WinProfi for communication with PROFITEST 0100S-II+</b>
13.1 Measuring Low-Value Resistance (function $R_{LO}$ ) .....	52		The PS3 CD-ROM includes the software WinProfi with the follow- ing content and functions:
13.2 Compensation for Extension Cables of up to 10 $\Omega$ (function $\Delta R_{LO}$ ) .....	54		<ul style="list-style-type: none"> <li>• up-to-date test instrument software for loading software version updates, prerequisite: connection has been established between test instrument and PC</li> <li>• Exchange of measured data between SI module (accessories: <b>PROFITEST   SI-BC</b>, no standard equipment) and PC</li> <li>• Preparation, print-out and filing of test reports at the PC</li> </ul>
13.3 Calculation of Cable Lengths for Common Copper Conductors .....	54		The following interface converter is required for communication between test instrument and PC:
13.4 Setting the Limit Value .....	55		– IrDa-USB Converter (Z501J): IrDa (tester) – USB (PC)
<b>14</b>			The following interface cable is required for communication between SI module and PC:
<b>Phase Sequence Testing</b> .....	<b>55</b>		– Z3241: RS232 (SI module) – RS232 (PC)
<b>15</b>			
<b>Operating and Display Elements</b> .....	<b>57</b>		
16.1 Lamp Functions .....	66		
<b>17</b>			
<b>Maintenance</b> .....	<b>67</b>		
17.1 Self-Test .....	67		
17.2 Battery and Rechargeable Battery Operation, and Charging .....	69		
17.2.1 Initial Charging of NiMH or NiCd Batteries in the Test Instrument .....	69		
17.3 Fuses .....	70		
17.4 Housing .....	70		
17.5 Device Return and Environmentally Compatible Disposal .....	70		
<b>18</b>			
<b>Appendix</b> .....	<b>71</b>		

# 1 Applications

The **PROFITEST 0100S-II+** test instrument allows for quick and effective testing of protective measures in accordance with DIN VDE 0100 part 600:2008, ÖVE-EN 1 (Austria), SEV 3755 (Switzerland), as well as regulations specific to additional countries. The device is equipped with a microprocessor and complies with IEC 61557/EN 61557/VDE 0413 regulations:

Part 1: General requirements

Part 2: Insulation resistance testers

Part 3: Loop resistance testers

Part 4: Instruments for the measurement of resistance at earthing conductors, protective conductors and bonding conductors

Part 5: Earthing resistance testers

Part 6: Instruments for the testing of proper functioning of residual current devices (RCDs) and the effectiveness of protective measures in TT and TN systems

Part 7: Phase sequence testers

Part 10: Combined measuring equipment for testing, measuring or monitoring of protective measures

It is especially suited for:

- Systems set-up
- Initial start-up
- Periodic testing
- Troubleshooting for electrical systems

All measurement values required for approval reports (e.g. ZVEH) can be acquired with the instrument.

The applications range of the **PROFITEST 0100S-II+** can be expanded with the attachable SI module (optional) which includes memory and integrated interface.

All acquired data can be archived, in addition to the measurement and test reports which can be printed out at a PC. This is of spe-

cial significance where product liability is concerned.

The applications range of the **PROFITEST 0100S-II+** covers all alternating and three-phase current systems with nominal voltages of 230 V (240 V if “English/UK-parameter” has been selected in setup) / 400 V (300 V / 500 V) and nominal frequencies of 16<sup>2/3</sup> / 50 / 60 / 200 / 400 Hz.

The following measurements and tests can be performed with the **PROFITEST 0100S-II+**:

- Voltage / frequency / phase sequence
- Loop impedance / line impedance
- RCD protection
- Earthing resistance / earth electrode potential
- Standing surface insulation resistance / insulation resistance
- Earth leakage resistance
- Low-value resistance (potential equalization)
- Leakage currents with clip-on current transformer
- Meter start-up
- Cable length

## Meaning of Symbols on the Instrument



Warning concerning a point of danger  
(Attention, observe documentation!)



Safety class II device



9 V DC charging socket  
for NA 0100S battery charger



This device may not be disposed of with the trash. Further information regarding the WEEE mark can be accessed on the Internet at [www.gossenmetra-watt.com](http://www.gossenmetra-watt.com) by entering the search term 'WEEE'.



EC label of conformity



KEMA KEUR approval mark



IMQ approval mark

## 2 Safety Features and Precautions

This instrument fulfills the requirements of the applicable European and national EC guidelines. We confirm this with the CE marking. The relevant declaration of conformity can be obtained from GMC-I Messtechnik GmbH.

The **PROFITEST 0100S-II+** electronic measuring and test instrument is manufactured and tested in accordance with safety regulations IEC 61010-1/EN 61010-1/VDE 0411-1.

When used for its intended purpose, safety of the operator, as well as that of the instrument, is assured.

**Read the operating instructions thoroughly and carefully before placing your instrument into service, and follow all instructions contained therein. Make sure that the operating instructions are available to all users of the instrument.**

**Tests may only be performed under the supervision of a qualified electrician. The user must be instructed by a qualified electrician concerning performance and evaluation of the test.**



### Note

Manufacturers and importers of electrical medical devices must provide documentation for the performance of maintenance by trained personnel.

Grip and hold the test plug and test probes securely when they have been inserted, for example, into a socket. Danger of injury exists if tugging at the coil cord occurs, which may cause the test plug or test probes to snap back.

### The measuring and test instrument may not be placed into service:

- if the battery compartment lid has been removed
- if external damage is apparent
- if connector cable or measuring adapters are damaged
- if the instrument no longer functions flawlessly
- after a long period of storage under unfavorable conditions (e.g. moisture, dust, extreme temperatures).

### Exclusion of Liability

When **testing systems with RCCBs**, the latter may switch off. This may occur even though the test does not normally provide for it. Leakage currents may be present which, in combination with the test current of the test instrument, exceed the shutdown threshold value of the RCCB. PCs which are operated in proximity to such RCCB systems may switch off as a consequence. This may result in inadvertent loss of data. Before conducting the test, precautions should therefore be taken to ensure that all data and programs are adequately saved and the computer should be switched off, if necessary. The manufacturer of the test instrument assumes no liability for any direct or indirect damage to equipment, computers, peripheral equipment or data bases when performing the tests.

### Data Backup

Measurement data and electrical circuit assignments can be safely stored in the RAM of a SI module which is attached to the test instrument (accessory **PROFITEST | SI-BC**, no standard equipment) as long as the associated battery supplies the required voltage. We advise you to regularly transmit your stored data to a PC in order to prevent potential loss of data in the test instrument. We assume no responsibility for any data loss. For data processing and management we recommend the following PC software programs:

- PS3 (documentation, management, report generation and monitoring of deadlines)
- PC.doc-WORD™/EXCEL™ (report and list generation)
- PC.doc-ACCESS™ (test data management)

## 3 Initial Start-Up

### 3.1 Installing or Replacing Batteries



#### Attention!

Before opening the battery compartment, disconnect the instrument from the measuring circuit (mains) at all poles!

Six commercially available 1.5 V mignon cells in accordance with IEC LR 6 are required for operation of the **PROFITEST 0100S-II+**.

Only alkaline manganese cells may be used which comply with IEC LR 6. The use of zinc-carbon batteries is to be avoided due their short service life.



#### Note

Rechargeable NiCd or NiMH cells may also be used. See also chapter 17.2 on page 69 concerning charging and the battery charger.

Always replace batteries in complete sets.

Dispose of batteries in an environmentally sound fashion.

- ⇨ Loosen the slotted screw at the Battery Compartment Lid (28) and remove the lid.
- ⇨ Pull the Battery Holder (27) out with the strap and insert six 1.5 V mignon cells with plus and minus poles in accordance with the symbols on the holder.
- ⇨ Insert the Battery Holder (27) with batteries into the battery compartment (strap must be positioned beneath the holder). The holder can only be inserted in its proper position.
- ⇨ Replace the lid and retighten the screw.



#### Attention!

The instrument may only be placed into service if the battery compartment lid is securely fastened!

### 3.2 Selecting a Language, Basic Function and Sub-Function Settings



Any of the available languages can be selected by pressing the Menu Key (4).

If the "English/UK-parameter" has been selected, the following differences apply to the other menu items:

- Nominal voltage of 240 V instead of 230 V
- RCD trip test includes 2 sec. at 50% (nominal fault) current before RCD is tripped
- No autom. change Phase to Neutral for socket outlets wired incorrectly

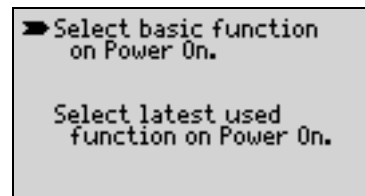
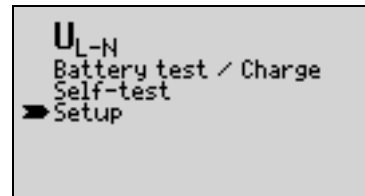



By pressing the Menu Key (4), you can determine whether the basic instrument functions are made available when the instrument is switched on, or if the last selected sub-function is made available for immediate measurement.



**Note**

The basic functions are selected automatically if the Function Selector Switch (9) has been activated. If the device is in self-test mode, self-testing must first be completed!

**Display Illumination**

Display illumination can be deactivated by pressing the Menu Key (4) in order to extend the service life of the batteries.

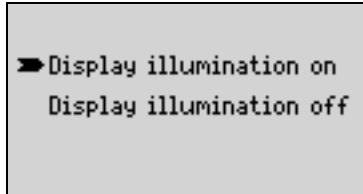

**On-Time**

The period of time after which the test instrument is automatically shut off can be selected here with the Menu Key (4).

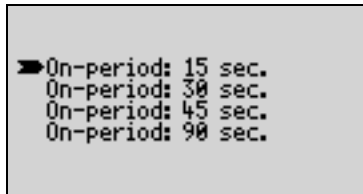

The selected on-time has as substantial influence on battery service life.

**3.3 Battery Test**

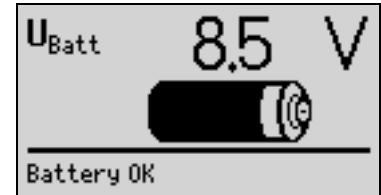
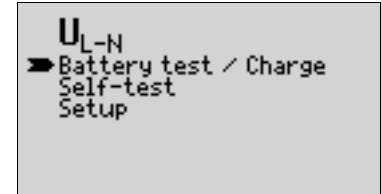
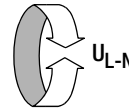

**Note**

Batteries or rechargeable batteries are tested under load conditions. When the Start Key ▼ (3 or 17) is activated, the NETZ/MAINS,  $U_L/R_L$  and FI/RCD lamps light up briefly for this reason.

If battery voltage has fallen below the allowable lower limit, the symbol to the right appears:

The instrument does not function if the batteries have been depleted excessively, and no display appears.

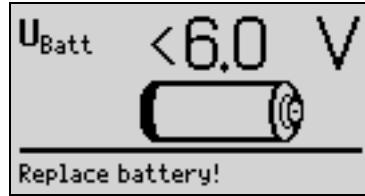

### 3.4 Recharging the Batteries



#### Attention!

Use only the NA 0100S battery charger with reliable electrical isolation and a nominal secondary value of 9 V DC for the recharging of batteries. Before connecting the charger to the charging socket make certain that:

- **Rechargeable batteries have been installed (not standard batteries)**
- The instrument has been disconnected from the measuring circuit at all poles

Connect the NA 0100S battery charger to the charging socket at the side of the housing bottom with the 3.5 mm jack plug. Set the voltage selector switch at the NA 0100S to 9 V.

Charging is started with the same procedure as used for the battery test. The instrument detects the presence of the charger and initiates the charging process.

Depleted batteries (display < 6 V) require approximately 4 hours for complete charging. The test instrument cannot be switched on if the batteries are severely depleted. In such a case, leave the instrument switched on with battery charger connected for about 30 minutes, and then proceed as described above.

### 3.5 Downloading a Software Update, Managing Report Data

If you require an updated test instrument software, it can be downloaded with the help of WinProfi PC software. The data file with the desired software version is transmitted to the test instrument via the serial interface. The previously installed language is overwritten.



#### Note

This software includes all of the functions required for communications between the **PROFITEST 0100S-II+** and the PC. A description of the program is included in the online user's manual which can be accessed from WinProfi.

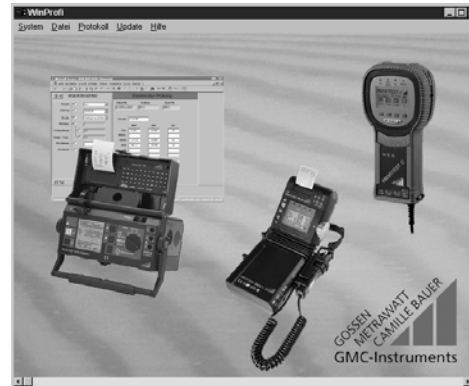

WinProfi Software

## A Install WinProfi to the PC and Start the Program

- ⇒ First install the software to your PC. Insert the CD into the CD drive, for example drive E. Execute the file **E:\GMCDEMO**
  - ⇒ Click the globe icon.
  - ⇒ Follow the instructions which appear at the monitor.
- The program is added to your START menu after installation.

- ⇒ Establish a connection between your PC and the **PROFITEST 0100S-II+** test instrument by using the IrDa-USB converter.
- ⇒ Start WinProfi.
- ⇒ Switch on the test instrument by pressing the Menu Key.
- ⇒ Set the on-time period of the **PROFITEST 0100S-II+** to 90 s to give you enough time for adjusting the settings in WinProfi before the test instrument switches off again automatically, see chapter 3.2.

## Display or print out online user's manual

The online manual contains information concerning the software which is not included in these operating instructions.

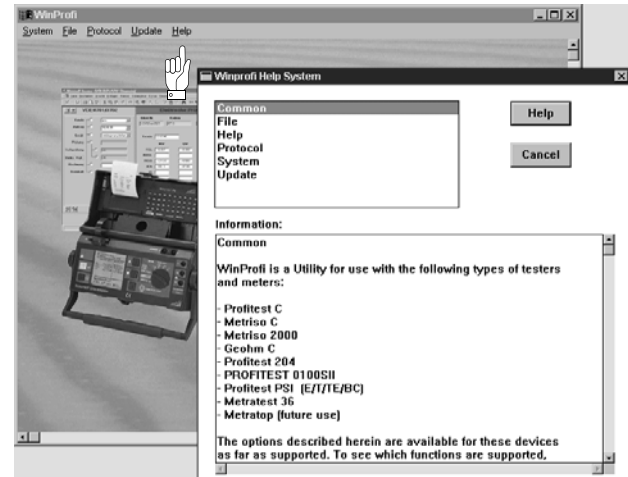

## B Prerequisites for Software Update or Data Exchange

- ⇒ Find the interface to which the **PROFITEST 0100S-II+** is connected.

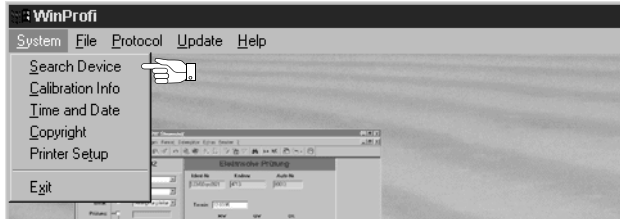

### Note

Always start this function first, **before performing an update or changing report templates**. After starting this function, WinProfi loads the report files specifically necessary for the connected instrument. Due to the fact that WinProfi has been created for use with several types of test instruments, incorrect test reports may otherwise be loaded, or erroneous options may be made available.

- ⇒ Query information regarding current software version.

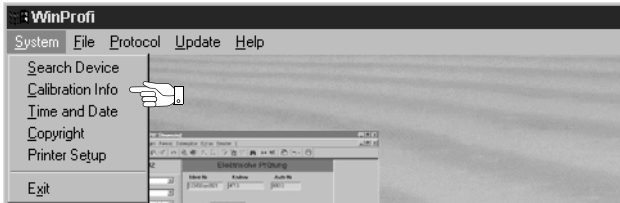

## C Transmission of a Software Update to the Test Instrument

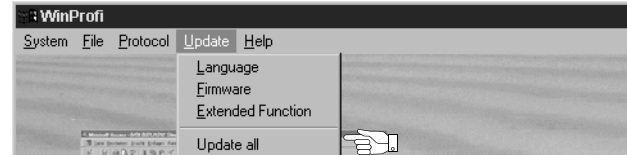

- ⇒ **PC:** Select the **Update All** function from the **Update** menu. Follow the instructions which appear at the monitor.

Depending upon the utilized PC, transmission takes from 1 to 2 minutes.

*The NETZ/MAINS LED of the **PROFITEST 0100S-II+** test instrument lights up green and indicates that the instrument is ready to receive data. If the PC and the test instrument are correctly synchronized, the same LED lights up yellow. During programming sequences, the  $U_L/R_L$  and FI/RCD LEDs light up red and the NETZ/MAINS LED lights up yellow in alternating order. Upon completion of data transmission, the NETZ/MAINS LED briefly lights up green, afterwards all LEDs go out.*

*The message „Transmission done“ appears on the computer screen.*



### Attention!

The instrument may not, under any circumstances, be switched off during transmission, nor may the connection between the instrument and the PC be interrupted!

## D Managing Report Data

The following functions can only be performed with a SI module since the measuring and test data can only be saved in this module.

- Connect the SI module with your PC via the Z3241 cable (the SI module does not have to be connected with the test instrument).

- Send or receive a data file

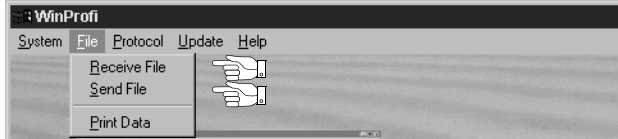

- Print data

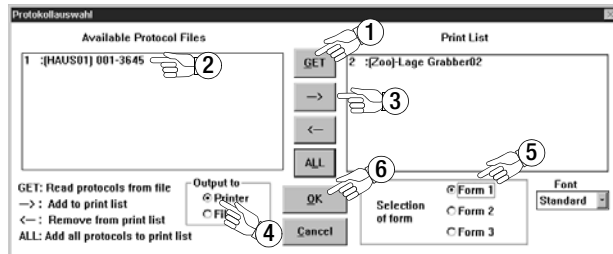
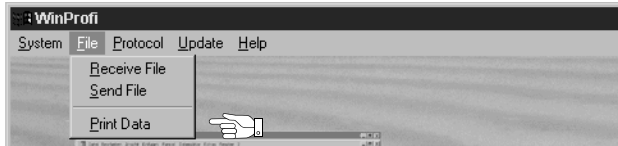

- Edit or transmit report templates

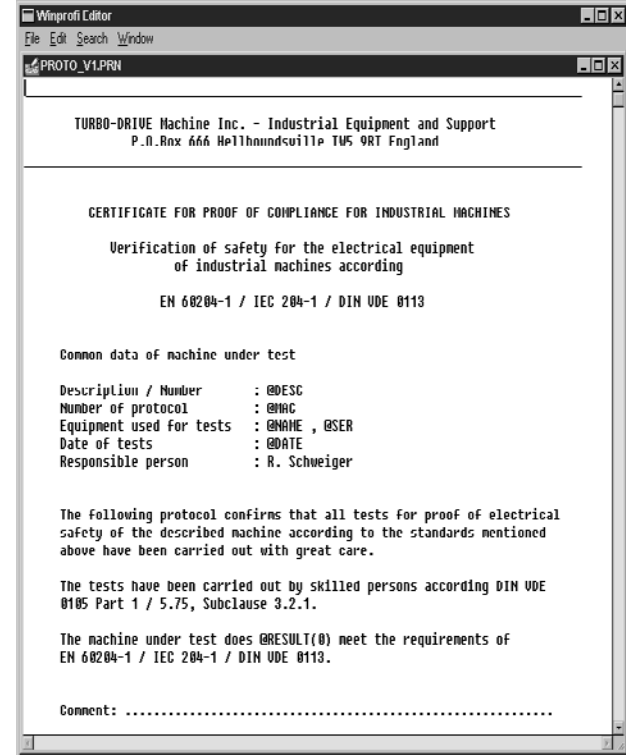
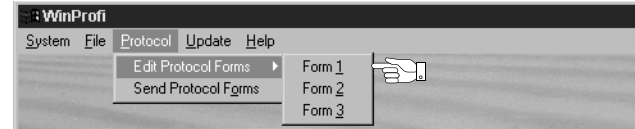

## 4 Abbreviated Instructions for Quick Initial Start-Up

The performance of measurements and testing with the **PROFITEST 0100S-II+** is quick and easy.

The integrated on-line help and the abbreviated instructions are sufficient for most measurements. Nevertheless, you should read and observe the instructions which follow these abbreviated instructions as well.

### Terminology

**Basic Function** The basic functions are selected with the Function Selector Switch (9). The basic function is the first entry in the menu window and is automatically selected when the function selector switch is activated.

**Sub-Function** Functions which are subordinate to the basic function in the menu window. Sub-functions are selected with the yellow Menu Key (4), and are subsequently highlighted with the arrow.

Measurements can be performed as follows for all measuring functions:

### 1 Select the basic function with the Function Selector Switch (9)

⇒ Turn the Function Selector Switch (9) to the desired basic function.

### 2 Connect the test instrument

⇒ Connect the Test Plug (14) with attached Plug Insert (13) to the mains outlet, or connect the instrument directly in a 2-pole manner with the plug-on Measuring Adapter (2-pole) (12).

After a basic function or a sub-function has been selected as described below, the corresponding circuit diagram can be queried at the LC Display Field (1) by pressing the  $I_{\Delta N}$  / i key (2 or 18).

### 3 Selecting a basic function or a sub-function with the Menu Key (4)

When the Menu Key (4) is first activated, the instrument is switched on. The basic function and its corresponding sub-functions are displayed in the menu:

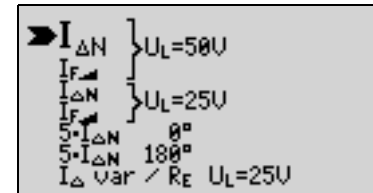
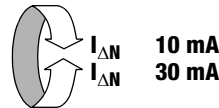
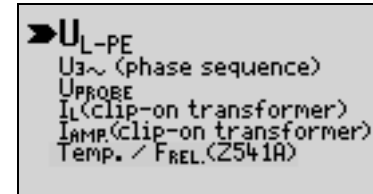
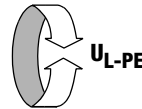
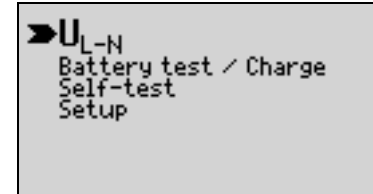
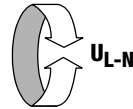

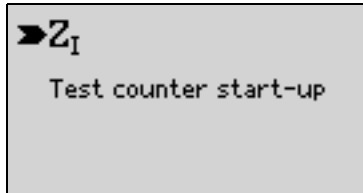
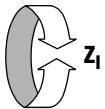
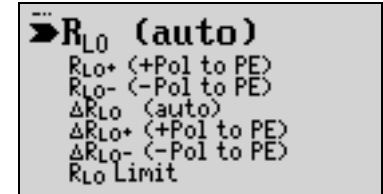
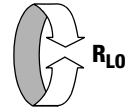
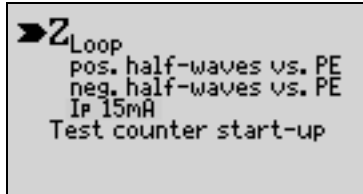
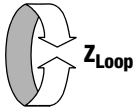
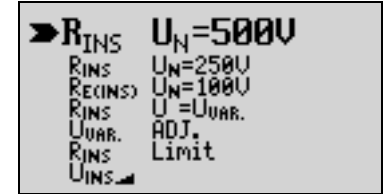
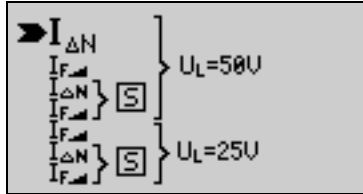
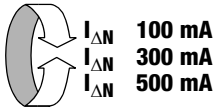

⇒ Repeatedly press the Menu Key (4) until the arrow points to the desired function.

On-line help can be queried for any selected function with the  $I_{\Delta N}$  / i keys (2 or 18).

The selection of a function is not necessary if basic functions and sub-functions have been pre-configured as described.

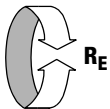

**4** Start measurement with the Start Key ▼ (3 or 17) and read measurement results

⇒ Press the  $I_{\Delta N}$  key (2 or 18) during the on-time period (before the instrument has shut itself off automatically) in order to perform the tripping test for RCCBs.

## 5 General Instructions

### 5.1 Connecting the Instrument

For systems with earthing contact sockets, connect the instrument with the Test Plug (14), on which the Plug Insert (13) is attached, to the mains. Voltage between phase conductor L and the PE protective conductor may not exceed 253 V!

Poling at the socket need not be taken into consideration. The instrument detects the positions of phase conductor L and neutral conductor N, and automatically reverses poles if necessary. This does not apply to the following measurements:

- Voltage measurement in selector switch position  $U_{L-PE}$
- Insulation resistance measurement
- Low-value resistance measurement
- Phase sequence testing
- Selection of “English/UK-parameter” in setup. In this case no automatic pole reversal occurs.

The positions of phase conductor L and neutral conductor N are identified at the Plug Insert (13).

If measurement is to be performed at three-phase outlets, at distribution cabinets or at permanent connections, the Measuring Adapter (2-pole) (12) must be fastened to the Test Plug (14) (see also table 16.1). Connection is established with the test probes: one at PE or N and the other at L.

The 2-pole measuring adapter must be expanded to 3 poles with the included measurement cable for the performance of phase sequence testing. Measurements with the Measuring Adapter (2-pole) (12) are not possible with the Function Selector Switch (9) in the  $U_{L-N}$  or  $Z_1$  positions. These measurements can be performed in selector switch positions  $U_{L-PE}$  and  $Z_{Loop}$ .

Contact voltage (during RCCB testing) and earthing resistance can be, and earth-electrode potential, standing surface insulation resistance, probe voltage and RCCB performance in IT systems

must be measured with a probe. The probe is connected to the Probe Connector Socket (20) with a 4 mm contact protected plug.

### 5.2 Automatic Settings, Monitoring and Shut-Off

The **PROFITEST 0100S-II+** automatically sets all operating conditions which it is able to determine itself. It tests line voltage and frequency. If these lie within their valid nominal ranges, they appear at the LC Display Field (1). If they are not within nominal ranges, prevailing voltage (U) and frequency (f) are displayed instead of  $U_N$  and  $f_N$ .

**Line voltage fluctuations** have no effect on measurement results.

**Contact voltage** which is induced by test current is monitored for each measuring sequence. If contact voltage exceeds the limit value of > 25 V or > 50 V, measurement is immediately interrupted. The  $U_L$  (7) lamp lights up red.

If **battery voltage** falls below the allowable limit value the instrument cannot be switched on, or it is immediately switched off.

The measurement is interrupted automatically, or the measuring sequence is blocked (except for voltage measuring ranges and phase sequence testing) in the event of:

- non-allowable line voltages (< 60 V, > 253 V / > 330 V / > 440 V or > 550 V) for measurements which require line voltage
- interference voltage during insulation resistance or low resistance measurements
- overheating at the instrument.

As a rule, excessive temperatures only occur after approximately 500 measurement sequences at intervals of 5 s, when the Function Selector Switch (9) is set to the  $Z_{Loop}$  or  $Z_1$  position.

If an attempt is made to start a measuring sequence, an appropriate message appears at the LC Display Field (1).



The instrument only switches itself off automatically after completion of an automatic measuring sequence, and after the predetermined on-time has expired (see chapter 3.2). On-time is reset to its original value as defined in the setup menu, as soon as any key or the Function Selector Switch (9) is activated.

The instrument remains on for approximately 75 s in addition to the preset on-time for measurements with rising residual current in systems with selective RCDs.

The instrument always shuts itself off automatically!

### 5.3 Measurement Value Display and Memory

The following appear at the LC Display Field (1):

- Measurement values with abbreviations and units of measure
- Selected function
- Nominal voltage
- Nominal frequency
- Error messages

Measurement values for automatic measuring sequences are stored and displayed as digital values until the next measurement sequence is started, or until automatic shut-off occurs.

If the measuring range upper limit is exceeded, the upper limit value is displayed and is preceded by the ">" symbol (greater than), which indicates measurement value overrun.

### 5.4 Testing Earthing Contact Sockets for Correct Connection

The testing of earthing contact sockets for correct connection prior to protective measures testing is simplified by means of the instrument's error detection system. The instrument indicates improper connection as follows:

- **Non-allowable line voltage (< 60 V or > 253 V):**  
The NETZ/MAINS Lamp (6) blinks red and the measuring sequence is blocked.

- **Protective conductor not connected or potential to earth  $\geq 100$  V at  $f > 45$  Hz:** The PE Lamp (5) lights up red when contact is made with the Contact Surfaces (19).

*The measurement is not blocked when the lamp is lit. It does not light up, i.e. is not functional, when the instrument is switched on and the Function Selector Switch (9) is in the  $U_{L-N}$  or the  $Z_I$  position (see Lamp Functions on page 66).*



#### Note

If the instrument is off and the selector switch is in the  $U_{L-N}$  or the  $Z_I$  position, the red PE lamp may light up if contact is made with the Contact Surfaces (19), and if the terminal designated N at the plug insert is connected to the phase conductor at the socket.

- **Neutral conductor N not connected:**

The NETZ/MAINS Lamp (6) blinks green (see Lamp Functions on page 66).

- **One of the two protective contacts is not connected:**

Testing for this condition is performed automatically for the  $F_I$ ,  $Z_I$ ,  $Z_{Loop}$  and  $R_E$  functions. Poor contact resistance at one of the contacts leads to one of the following displays depending upon poling of the plug:

- A value of only approximately half the anticipated line voltage is displayed.
- A "STOP-sign" with the following warning appears: "Earthing resistance to high or defective fuse".



#### Attention!

Reversal of N and PE in a system without RCCBs cannot be detected and is not indicated by the instrument. If an RCCB is present in the system, it is tripped during  $Z_I$  measurement if N and PE have been reversed.

## 5.5 Help Function

The appropriate circuit diagrams and on-line help can be queried at the LC Display Field (1) for each of the basic functions and sub-functions, **after these have been selected in the corresponding menu.**

 Press the  $I_{\Delta N}$  / i key (2 or 17) once to display the circuit diagram. Press the same key again to alternate between the circuit diagram and on-line help.



 Press the Menu Key (4) to exit the help function.



## 6 Measuring Alternating Voltage and Frequency

### 6.1 Voltage between L and N ( $U_{L-N}$ )

Set-Up

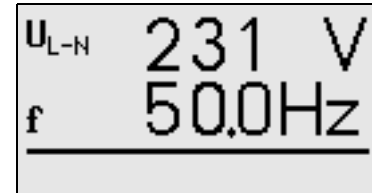
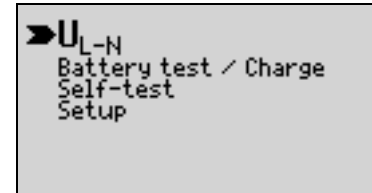
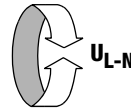
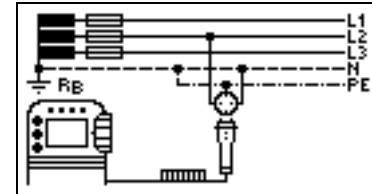

#### Note

Measurements cannot be made with the Measuring Adapter (2-pole) (12) in the  $U_{L-N}$  function!

## 6.2 Voltage between L and PE, N and PE, as well as L and N Set-Up

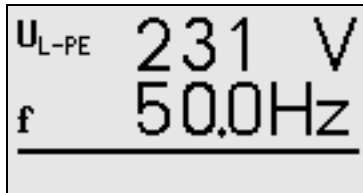
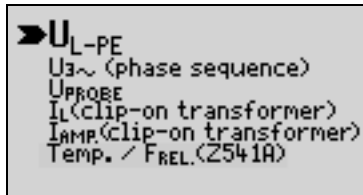
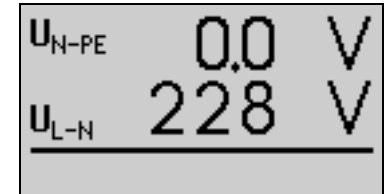
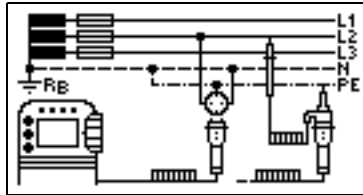
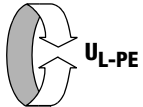

The display is switched to the other two voltages measured at the socket by pressing the  $I_{\Delta N} / i$  key. The previous display can only be recalled by pressing the START key.

### 6.3 Voltage between the Probe and PE ( $U_{S-PE}$ )

Set-Up

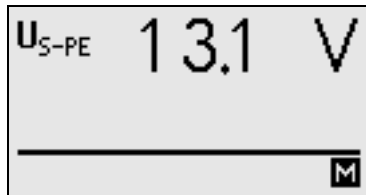
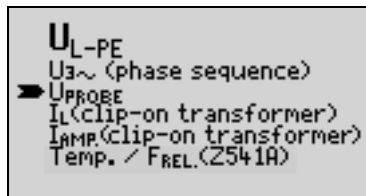
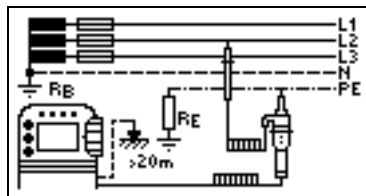
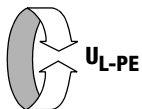

### 6.4 Measuring Current with a Clip-On Current Transformer

Bias, leakage and circulating current to 1 A, as well as leakage current to 150 A can be measured with the help of the 0100S Clip, special clip-on current transformer, which is connected at the charging socket.



**Attention!**

**High-Voltage Danger!**

Use only the above mentioned clip-on current transformer. Other current clips may not be terminated with an output load at the secondary side. Dangerously high voltage may endanger the user and the device in such cases.

The maximum allowable operating voltage is equal to the nominal voltage of the current transformer. Take additional display error into consideration when reading the measurement value.



**Attention!**

Do not, under any circumstances, connect any accessories to the charging socket which have not been recommended and approved by GMC-I Messtechnik GmbH! The instrument and the user may otherwise be endangered and may suffer damage or injury.

All other instrument test functions are blocked if the clip-on current transformer or the battery charger is connected. If you nevertheless attempt to activate another function, the following message appears: "remove adapter". No testing is performed. After the clip-on current transformer or the battery charger has been removed, this message disappears automatically for functions involving long-term measurements (e.g. voltage measurement). For other functions it disappears as soon as a new measurement is started, or when a new function is selected.

If no clip-on current transformer has been connected for the  $I_L$  or  $I_{AMP}$  function, the following message appears: "use current clip".

### Set-Up

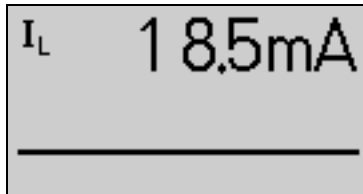
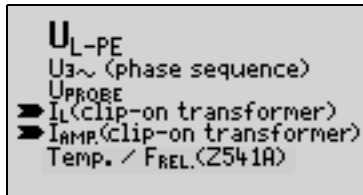
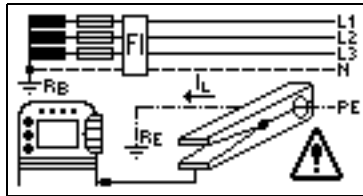

The switch position at the respective clip-on current transformer must be matched to the ranges of the selected measuring parameter,  $I_L$  or  $I_{AMP}$ !

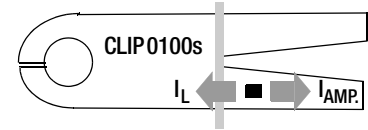

Measuring Range	Tester	CLIP0100S	Z3512A *
$I_L$	5 mA ... 1.0 A	1 mA... 15 A	d: 1 mA ... 1 A
$I_{AMP}$	10 ... 150 A	1 A ... 150 A	a: 1 ... 1000 A

\* Connection via CLIP-ON adapter cable (Z501G); ranges b and c not possible in this case.

## 6.5 Z541A Temperature and Humidity Measuring Adapter

The test instrument's range of applications for floor measurements is significantly expanded with this optionally available adapter. In order to activate the **Temp/H.Rel.** function, select the last menu item with the rotary switch in the  $U_{L-PE}$  position.

If the adapter is plugged in, room temperature and relative humidity are displayed. "Z541A – OK" appears in the status line. In order to exit the temperature and humidity measuring function, press and hold the Menu key (approx. 1 s) at the test instrument, or turn the function selector switch to another position.

No online help is available for this function. Temperature is always displayed in degrees Celsius. After using the Z541A, neither SI modules nor IrDa adapters may not be used with the **PROFITEST 0100S-II+** during remaining on-time. Wait until the test instrument shuts itself down, and then switch it back on again.

### Error Message at the Test Instrument

Error message "Z541A – ??????" may be caused by the following:

- Exposure of the infrared interface to sunlight
- Depleted batteries in the Z541A adapter
- Incorrectly seated or defective adapter

In order to avoid inadvertent start-up (due to infrared light), the Z541A adapter should not be exposed to intensive sunlight (battery service life!).

### Connection

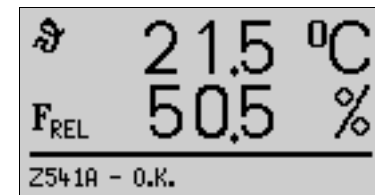
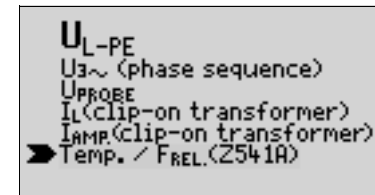
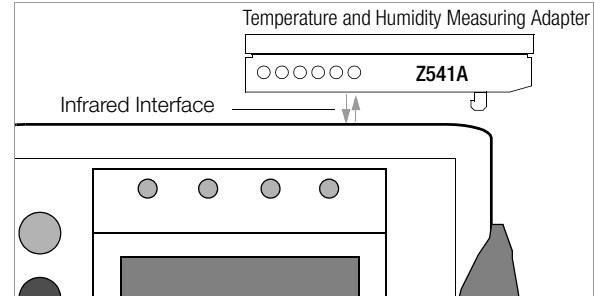

## 7 Testing RCDs

The testing of residual current devices (RCDs) includes:

- Visual inspection
- Testing
- Measurement

The **PROFITEST 0100S-II+** is used for testing and measurement. Measurements can be performed with or without a probe. However, a probe is always required for measurements in IT systems.

Measurements with probe require that the probe and reference earth are of like potential. This means that the probe must be positioned outside of the resistance area of the earth electrode ( $R_E$ ) at the RCD.

The distance between the earth electrode and the probe should be at least 20 m.

The probe is connected with a 4 mm contact protected plug.

In most cases this measurement is performed without probe.



### Attention!

The probe is part of the measuring circuit and may carry a current of up to 3.5 mA in accordance with VDE 0413.

Testing for the absence of voltage at the probe can be performed with the  $U_{\text{PROBE}}$  function. See also chapter 6.3 on page 20.

## 7.1 Measuring Contact Voltage (with reference to nominal residual current) with $\frac{1}{3}$ Nominal Residual Current and Tripping Test with Nominal Residual Current

### Set-Up

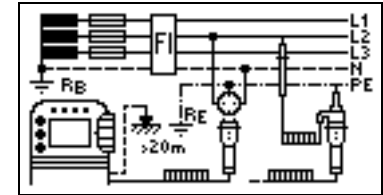

### Measuring Method

The following must be substantiated per DIN VDE 0100 part 610: 2004:

- Contact voltage occurring at nominal residual current may not exceed the maximum allowable value for the system.
- Tripping of the RCCB must occur within 400 ms (1000 ms for selective RCDs) at nominal residual current.

#### 1) Measurement of Contact Voltage

The instrument uses a measuring current of only  $\frac{1}{3}$  nominal residual current for the determination of contact voltage  $U_{\text{I,AN}}$  which occurs at nominal residual current. This prevents tripping of the RCCB.

This measuring method is especially advantageous, because contact voltage can be measured quickly and easily at any electrical outlet without tripping the RCCB.

The usual, complex measuring method involving testing for the proper functioning of the RCD at a given point, and subsequent substantiation that all other systems components requiring protection are reliably connected at low resistance values to the selected measuring point via the PE conductor, is made unnecessary.

Contact voltage  $U_{\Delta N}$  and calculated earthing resistance  $R_E$  appear at the LC Display Field (1).



#### Note

Displayed earthing resistance  $R_E$  is measured with relatively little current and may thus be inaccurate where small values are involved. Use the  $R_E$  selector switch position for accurate determination of earthing resistance.

After contact voltage has been measured, testing can be performed to determine whether or not the RCCB is tripped within 400 ms, or 1000 ms, at nominal residual current.

If the RCCB is tripped at nominal residual current, time to trip and earthing resistance are displayed.

If the RCCB is not tripped at nominal residual current, FI/RCD Lamp (8) lights up red.

The tripping test need only be performed at one measuring point for each RCCB.



#### Attention!

The measurement of contact voltage with 30% nominal residual current does not normally trip an RCCB. However, the trip limit may be exceeded as a result of leakage current in the measuring circuit, e.g. due to interconnected consumers with EMC circuit, e.g. frequency converters, PCs.

In order to prevent the loss of data in data processing systems, perform a data backup before starting the measurement and switch off all consumers.

If the “English/UK parameter” has been selected in setup, a 2 second test at 50% nominal residual current is performed before the RCD is tripped. If the RCD trips within this test period, the FI/RCD Lamp (8) also lights up red, and no trip delay is displayed.



#### Note

Interference voltages at protective conductor PE, at the earth electrode or at the probe (if properly connected) have no influence on measurement results. Interference voltages can be measured with the Measuring Adapter (2-pole) (12) by means of voltage measurement. If bias currents should occur, these can be measured with the help of a clip-on current transformer as described in chapter 6.4 on page 20. The RCCB may be tripped during the testing of contact voltage if extremely large bias currents are present within the system, or if a test current was selected which is too great for the RCCB. In such cases, the following message appears: “check test set-up”.

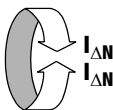

$I_{\Delta N}$  10 mA  
 $I_{\Delta N}$  30 mA

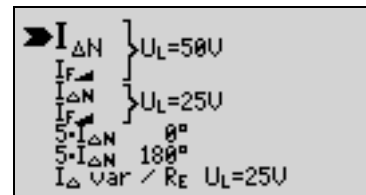



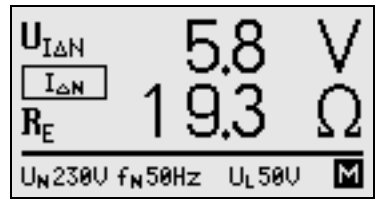
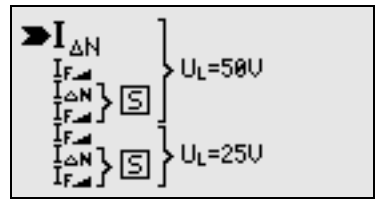
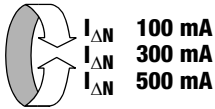

If contact voltage  $U_{I_{\Delta N}}$ , which has been measured with 1/3 nominal residual current  $I_{\Delta N}$  and expounded to  $I_{\Delta N}$ , is  $> 50\text{ V}$  ( $> 25\text{ V}$ ), the  $U_L/R_L$  (7) lamp lights up red.

If contact voltage  $U_{I_{\Delta N}}$  exceeds  $50\text{ V}$  ( $25\text{ V}$ ) during the measuring sequence, safety shut-down occurs. See also Note „Safety Shut-down“ on page 25.

Contact voltages of up to  $70\text{ V}$  are displayed. If contact voltage is greater than  $70\text{ V}$ ,  $U_{I_{\Delta N}} > 70\text{ V}$  is displayed.



**Note**

The measured earthing resistance value  $R_E$  is acquired with very little current. More accurate results can be obtained with the selector switch in the  $R_E$  position. Perform measurement upstream from the RCCB in order to prevent it from tripping in the case of the high measuring currents used in this context.

**Limit Values for Allowable, Continuous Contact Voltage**

The limit for allowable, continuous contact voltage is equal to  $U_L = 50\text{ V}$  for alternating voltages (international agreement). Lower values have been established for special applications (e.g. agricultural facilities  $U_L = 25\text{ V}$ ).



**Note**

**Safety Shut-down:** Up to  $70\text{ V}$ , a safety shut-down is tripped within  $3\text{ s}$  in accordance with IEC 61010.

**2) Tripping Test after the Measurement of Contact Voltage**

⇨ Press the  $I_{\Delta N}$  key (2 or 18) before on-time has expired (approximately 30 s).

If the RCCB is tripped at nominal residual current, the NETZ/ MAINS Lamp (6) blinks red (line voltage disconnected), and time to trip  $t_A$  and earthing resistance  $R_E$  appear at the LC Display Field (1).

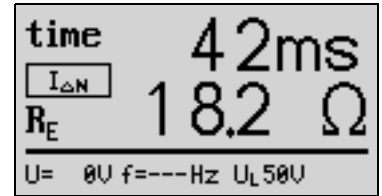

If the  $I_{\Delta N}$  key (2 or 18) is pressed again, the previous display appears at LC Display Field (1) for about 3 s.

If the RCCB is not tripped at nominal residual current, the FI/RCD Lamp (8) lights up red.



### Attention!

If contact voltage is too high, or if the RCCB is not tripped, the system must be repaired (e.g. earthing resistance is too high, defective RCCB etc.)!

For proper RCD testing at three-phase connections, the tripping test must be conducted for each of the three phase conductors (L1, L2 and L3).



### Note

Voltage peaks may occur within the measuring circuit if inductive consumers are shut down during an RCCB trip test. If this is the case, the test instrument may display the following message: "Check test setup". If this message appears, switch all consumers off before performing the trip test. In extreme cases one of the fuses in the test instrument may blow.

## 7.2 Special Testing for Systems and RCCBs

### 7.2.1 Testing for Systems and RCCBs with Rising Residual Current

#### Measuring Method

The instrument generates a continuously rising residual current of (0.3 ... 1.3) •  $I_{\Delta N}$  within the system for the testing of RCDs. The instrument stores the contact voltage and tripping current values which were measured at the moment tripping of the RCCB occurred, and displays them.

One of two contact voltage limit values,  $U_L = 25\text{ V}$  or  $U_L = 50\text{ V}$ , can be selected for measurement with rising residual current.

#### Set-Up

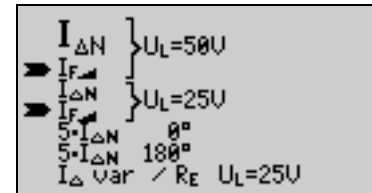
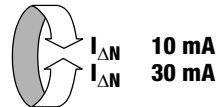
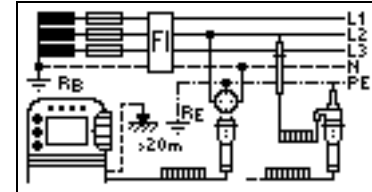

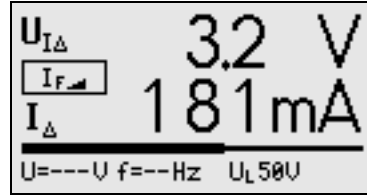
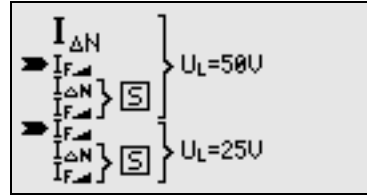
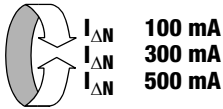

**Measuring Sequence**

After the measuring sequence has been started, the test current generated by the instrument is continuously increased starting at 0.3 times nominal residual current, until the RCCB is tripped. This rise can be observed at the horizontal bar display.

If contact voltage reaches the selected limit value ( $U_L = 50\text{ V}$  or  $25\text{ V}$ ) before the RCCB is tripped, safety shut-down occurs. The  $U_L/R_L$  (7) Lamp lights up red.

If the RCCB is not tripped before the rising current reaches nominal residual current  $I_{\Delta N}$ , the FI/RCD Lamp (8) lights up red.



**Attention!**

If bias current is present within the system during measurement, it is superimposed onto the residual current which is generated by the instrument and influences measured values for contact voltage and tripping current. See also note on page 24.

According to DIN VDE 0100, Part 610, rising residual current must, however, be used for measurements in the evaluation of RCCBs, and contact voltage at nominal residual current  $I_{\Delta N}$  must be calculated from the measured values. The faster, more simple measuring method should thus be taken advantage of (see chapter 7.1).

**7.2.2 Testing RCCBs with  $5 \cdot I_{\Delta N}$  (10 mA- and 30 mA)**

The measurement of time to trip is performed here with 5 times nominal residual current.



**Note**

Measurement performed with 5 times nominal fault current are required for testing RCCBs in the manufacturing process. They are used for personal safety as well.

Measurement can be started with the positive half-wave at “0°” or with the negative half-wave at “180°”.

Both measurements must nevertheless be performed. The longer of the two tripping times is decisive regarding the condition of the tested RCCB. Both values must be less than 40 ms.

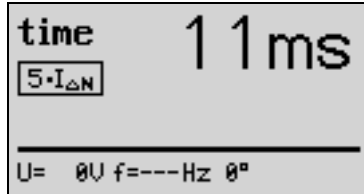
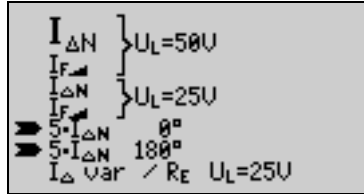
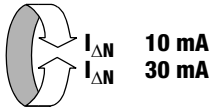

### 7.2.3 Testing of RCCBs which are Suited for Pulsating DC Residual Current

In this case, RCCBs can be tested with either positive or negative half-waves. The standard calls for tripping at 1.4 times nominal current.

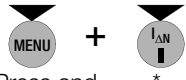

Press and hold the key!

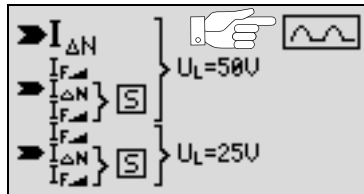

Press and hold the key!

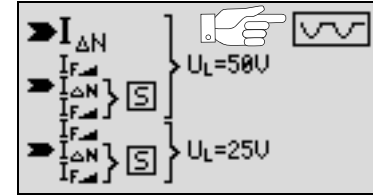

#### Note

According to DIN EN 50178 (VDE 160), RCCBs of type B (AC-DC sensitive) are sufficient for devices > 4 kVA, which are capable of generating smooth DC fault currents (e.g. frequency converters). Tests with pulsating DC fault currents are not suitable for these RCCBs. For this purpose we recommend the PROFITEST®DC-II adapter.



#### Note

Measurement is performed with positive and negative half-waves for testing RCCBs during manufacturing. If a circuit is charged with pulsating direct current, the function of the RCCB can be executed with this test in order to assure that the RCCB is not saturated by the pulsating direct current so that it no longer trips.

\* Press the key repeatedly until the symbol for positive or negative pulsating DC current appears.

## 7.3 Testing for Special RCDs

### 7.3.1 Systems with Selective RCDs

Selective RCDs are used in systems which include two series connected RCCBs which are not tripped simultaneously in the event of a fault. These selective RCDs demonstrate delayed response characteristics and are identified with the symbol **S**.

#### Measuring Method

The same measuring method is used as for standard RCCBs (see points 7.1 on page 23 and 7.2.1 on page 26).

If selective RCDs are used, earthing resistance may not exceed half of this value for standard RCCBs.

For this reason, the instrument displays twice the measured value for contact voltage.

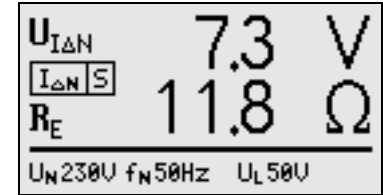
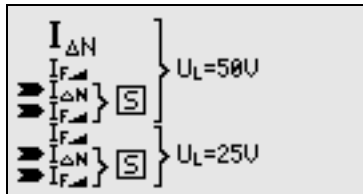
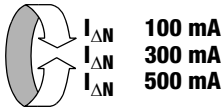

#### Tripping Test

- ⇒ Press the  $I_{\Delta N}$  key (2 or 18). The RCCB is tripped. The hour glass appears at the LC Display Field (1), which is followed by the display of time to trip  $t_A$  and earthing resistance  $R_E$ .



#### Note

Selective RCDs demonstrate delayed response characteristics. Tripping performance is briefly influenced (up to 30 s) due to pre-loading during measurement of contact voltage. In order to eliminate pre-loading caused by the measurement of contact voltage, a waiting period must be observed prior to the tripping test. After the measuring sequence has been started (tripping test), the hour glass appears in the LC Display Field (1). Times of up to 1000 ms are allowable.

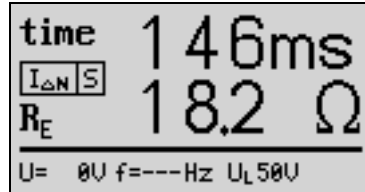
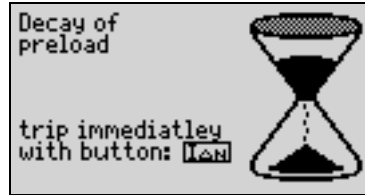

If the  $I_{\Delta N}$  key (2 or 18) is activated again, the LC Display Field (1) returns to the  $U_{I\Delta N}$  display.

### 7.3.2 PRCDs with Non-Linear Elements

#### Terminology (from DIN VDE 0661)

Portable protective devices are circuit breakers which can be connected between power consuming devices and permanently installed electrical outlets by means of standardized plug-and-socket devices.

A reusable, portable protective device is a protective device which is designed such that it can be connected to movable cables.

Please be aware that a non-linear element is usually integrated into PRCDs, which leads to immediate exceeding of the greatest allowable contact voltage during  $U_{I\Delta}$  measurements ( $U_{I\Delta}$  greater than 50 V).

PRCDs which do not include a non-linear element must be tested in accordance with chapter 7.3.3 on page 32.

#### Objective (from DIN VDE 0661)

Portable residual current devices (PRCDs) serve to protect persons and property. They allow for the attainment of increased levels of protection as provided by protective measures utilized in electrical systems for the prevention of electrical shock as defined in DIN VDE 0100 Part 410. They are to be designed such that they can be installed by means of a plug attached directly to the protective device, or by means of a plug with a short cable.

#### Measuring Method

The following can be measured, depending upon the measuring method:

- Time to trip  $t_A$ : tripping test with nominal residual current  $I_{\Delta N}$
- Tripping current  $I_{\Delta}$ : testing with rising residual current  $I_{F\Delta}$

Set-Up

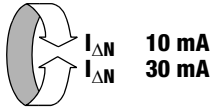
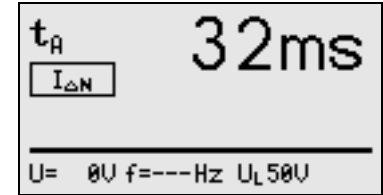
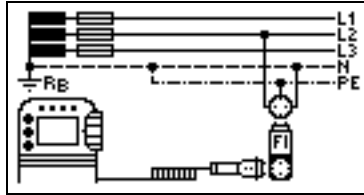

Display: menu page 2

$I_{\Delta N}$  }  $U_L=50V$  } SRCD/PRCD  
 $I_{F_{\Delta}}$  } with PE-  
 $I_{\Delta N}$  } control  
 $I_{F_{\Delta}}$  }  $U_L=25V$   
 $I_{\Delta N}$  } PRCD with non lin.  
 $I_{F_{\Delta}}$  } element in PE

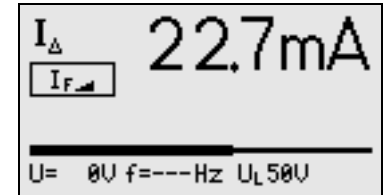

### 7.3.3 SRCDs, PRCDs (SCHUKOMAT, SIDOS or comparable)

RCCBs from the SCHUKOMAT, SIDOS series or others, which are of identical electrical design, must be tested in this selector switch position.

Monitoring of the PE conductor is performed for RCDs of this type. The PE conductor is monitored by the summation current transformer. If residual current flows from L to PE, tripping current is cut in half, i.e. the RCCB must be tripped at 50% nominal residual current  $I_{\Delta N}$ .

Whether or not PRCDs and selective RCDs are of like design can be tested by means of contact voltage  $U_{I\Delta N}$  measurement. If a contact voltage  $U_{I\Delta N}$  of greater than 70 V is measured at the PRCD of an otherwise error-free system, the PRCD more than likely contains a non-linear element.

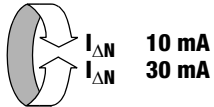

Depiction: menu page 2

```

    → I_{\Delta N} } U_L=50U } SRCD/PRCD
      I_{F\Delta} }          } with PE-
      I_{\Delta N} } U_L=25U } control
      I_{F\Delta} }          }
      I_{\Delta N} } PRCD with non lin.
      I_{F\Delta} } element in PE
  
```

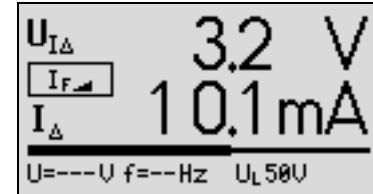
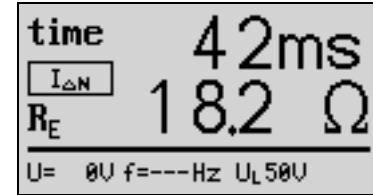
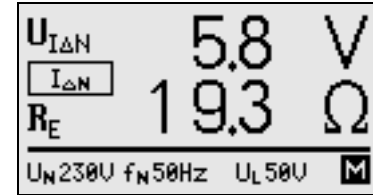



### 7.3.4 Type G RCCBs

In addition to standard RCCBs and selective RCDs, the special characteristics of the type G RCCB can also be tested with the **PROFITEST 0100 S-II+** test instrument.

- ⇒ Set the test instrument function selector switch to  $I_{\Delta N} = 30 \text{ mA}$  or  $10 \text{ mA}$ , and select the  $I_{\Delta N}$  menu item with the cursor.

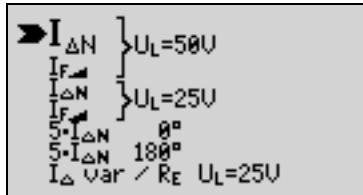
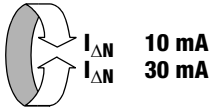

Contact voltage and time to trip can be tested in the same way as for standard RCCBs.



#### Note

It must be observed that time to trip for type G RCCBs may be as long as 1000 ms when measurement is made at nominal residual current. In such cases disregard the red FI/RCD Lamp.

- ⇒ Then select  $5 \times I_{\Delta N}$  in the menu and repeat the tripping test with the positive half-wave at  $0^\circ$  and the negative half-wave at  $180^\circ$ . The longer of the two tripping times is decisive regarding the condition of the tested RCCB.

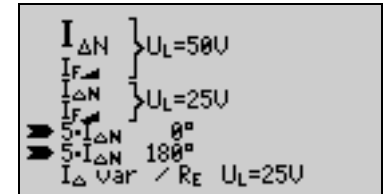

In both cases tripping time must be between 10 ms (minimum delay time for type G RCCBs!) and 40 ms.

Type G RCCBs with other nominal residual current values must be tested with the function selector switch in the corresponding position under menu item  $I_{\Delta N}$ . The red FI/RCD Lamp is disregarded in this case as well.



#### Note

Menu item S for selective RCDs is not suitable for type G RCCBs.

## 7.4 Testing with Adjustable Residual Current

The same tests as described in chapter 7.1 can be performed under menu item  $I_{\Delta VAR}/R_E$  except that all tests and measurements are performed with a test current which can be adjusted within a range of 3 mA to 550 mA. This function (e. g. contact voltage at the tripping contact) is suitable for the examination of RCD characteristics and contact voltage directly at the RCCB tripping contact, as well as for the determination of earthing resistance in systems with RCDs when no PROFITEST<sup>®</sup>DC-II is available for bridging the RCDs. This menu item can only be used for 10 mA and 30 mA RCCBs.

Proceed as follows in order to select the desired residual current:

- ⇒ Select menu item  $I_{\Delta VAR}/R_E$ .
- ⇒ Press the  $I_{\Delta N} / i$  key. A field for the entry of residual current appears.

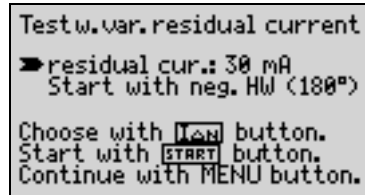

Each time the  $I_{\Delta N} / i$  is activated current is increased by 1 mA. By pressing and holding the  $I_{\Delta N} / i$  key, the value is increased continuously. The speed at which the value rises is increased after a few seconds. If the Menu Key is pressed and held at the same time, the value is reduced at the same speed. After the desired value has been set, testing can be started with the Start Key as described in chapter 7.1. Testing is started with the positive half-wave. If the test is to be started with the negative half-wave, the menu item "Start with negative half-wave (180 °)" must be selected prior to

testing.

If the Menu Key is pressed again, the main menu appears at the display. If no entries are made within approximately 10 s, the menu is exited.

The determination of contact voltage, as well as the tripping test, are performed with the pre-selected residual current.

If a residual current value is selected which is very close to the tripping current of the RCCB, the calculated contact voltage corresponds to the contact voltage which occurs at the moment the RCCB is tripped.

## 7.5 Testing RCDs in IT Systems

All of the tests described in chapters 7.1 through 7.5 can also be performed in IT systems with the PROFITEST 0100S-II+. The only prerequisite is that the system is capable of applying the necessary test and tripping currents to earth.

### Set-Up

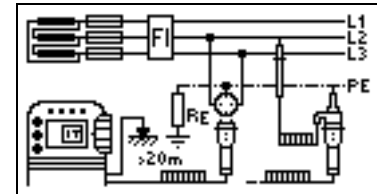

- ⇒ Connect the test instrument to the phase conductor which demonstrates the greatest earth potential.



### Attention!

Testing of RCCBs in IT systems cannot be performed without a probe; a probe is absolutely necessary! The probe and reference earth must be of like potential.

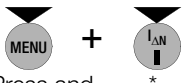
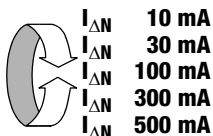

Press and hold the key!

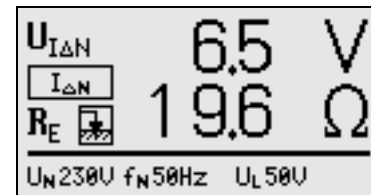
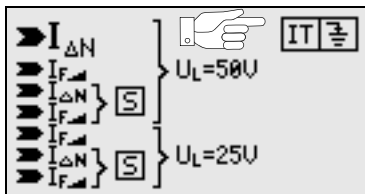

### Note

The MAINS Lamp (6) has no function for the testing of RCDs in IT systems (in the IT mode).

### Exit IT mode manually:

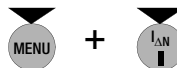

Press and hold the Menu Key and repeatedly press the I<sub>ΔN</sub>/I key until the IT symbol group and half-wave disappear.

### The IT mode is exited automatically if:

- an attempt is made to perform the measurement without a probe or if probe resistance is greater than 50 kΩ
- a prohibited bias occurs between the probe and earth
- the function selector switch (9) is turned
- the instrument shuts itself off automatically

\* Press the key repeatedly until the IT symbol group appears.

## 7.6 Testing Residual Current Circuit Breakers in TN-S Systems

### Connections

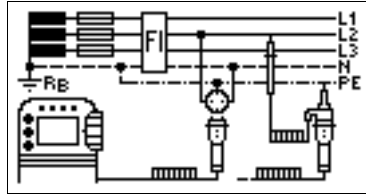

RCCBs can only be used in TN-S systems. An RCCB would not work in a TN-C system because PE is directly connected to the neutral conductor in the outlet (it does not bypass the RCCB). This means that residual current would be returned via the RCCB and would not generate any differential current, which is required in order to trip the RCCB.

In determining contact voltage and earth resistance, it must be kept in mind that loop impedance  $Z_{Loop}$  is determined rather than earth resistance  $R_E$ .

Due to minimal measuring current with a value of, for example, 10 mA for a 30 mA RCCB, resolution is only  $3 \Omega$  for  $R_E (=Z_{Loop})$ . Since loop resistance is generally less (e.g.  $1 \Omega$ ),  $0 \Omega$  is displayed in most cases.



#### Note

Observe national regulations, e.g. the necessity of conducting measurements without regard for RCCBs in Austria, see also chapter 8.3.

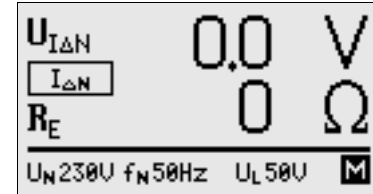

As a rule, the display for contact voltage is also 0.0 V, because the nominal residual current of 30 mA together with minimal loop resistance result in a very small voltage value:

$$U_{I\Delta N} = R_E \cdot I_{\Delta N} = 1\Omega \cdot 30\text{mA} = 30\text{mV} = 0,03\text{V}$$

Measuring resolution is 100 mV, and the display value is thus rounded down to 0.0 V.

## 8 Testing of Breaking Requirements for Overcurrent Protective Devices, Measurement of Loop Impedance and Determination of Short-Circuit Current (functions $Z_{Loop}$ and $I_K$ )

Testing of overcurrent protective devices includes visual inspection and measurement. The **PROFITEST 0100S-II+** is used for the performance of measurements.

### Measuring Method

Loop impedance  $Z_{Loop}$  is measured and short-circuit current  $I_K$  is ascertained in order to determine if the breaking requirements for protective devices have been fulfilled.

Loop impedance is the resistance within the current loop (utility company plant – phase conductor – protective conductor) when a short-circuit to an exposed conductive part occurs (conductive connection between phase conductor and protective conductor). Short-circuit current magnitude is determined by the loop impedance value. Short-circuit current  $I_K$  may not fall below a predetermined value set forth by DIN VDE 0100, so that reliable breaking of the protective device (fuse, automatic circuit breaker) is assured.

Thus the measured loop impedance value must be less than the maximum allowable value.

Tables containing allowable display values for loop impedance and minimum short-circuit current display values for ampere ratings for various fuses and circuit breakers can be found in chapter 18 starting on page 71. Maximum device error in accordance with VDE 0413 has been taken into consideration in these tables. See also chapter 8.2.

In order to measure loop impedance  $Z_{Loop}$ , the instrument uses a test current of 0.83 A to 4 A dependent upon line voltage and line frequency. The test has a duration of max. 600 ms.

If dangerous contact voltage occurs during measurement (> 50 V), safety shut-down occurs.

The test instrument calculates short-circuit current  $I_K$  based on measured loop impedance  $Z_{Loop}$  and line voltage. Short-circuit current calculation is made with reference to nominal line voltage for line voltages which lie within the nominal ranges for 120 V, 230 V (240 V for „English/UK-parameter“) and 400 V systems. If line voltage does not lie within these nominal ranges, the instrument calculates short-circuit current  $I_K$  based upon prevailing line voltage and measured loop resistance  $Z_{Loop}$ .

Loop resistance can be measured with either the positive or the negative half wave with the **PROFITEST 0100S-II+**. This measuring method, in combination with the PROFITEST®DC-II adapter, allows for the measurement of loop impedance in systems which are equipped with RCCBs.

A four conductor measuring cable is used between the instrument and the Test Plug (14). Cable and measuring adapter (12) resistance is automatically compensated for during measurement and does not effect measurement results.

## Set-Up

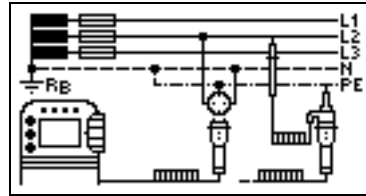
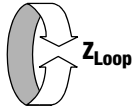

```

➔ ZLoop
pos. half-waves vs. PE
neg. half-waves vs. PE
Ip 15mA
Test counter start-up
    
```

```

ZLoop 2.21 Ω
┌───┴───┐
Ip 104 A
└───┬───┘
UN 230V fN 50Hz
    
```

Measurement of loop impedance to earth must be performed at all three phase conductors (L1, L2, and L3) for the testing of over-current protective devices at three phase outlets.

## 8.1 Measurement with Positive or Negative Half-Waves

Measurement by means of half-waves in combination with the PROFITEST®DC-II adapter allows for the measurement of loop impedance in systems which are equipped with RCCBs.

### Set-Up

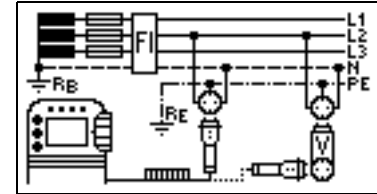
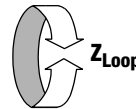

```

ZLoop
➔ pos. half-waves vs. PE
➔ neg. half-waves vs. PE
Ip 15mA
Test counter start-up
    
```

Whether positive or negative half-waves are used for the measurement depends upon the poling of DC biasing at the ballast. If the RCCB is tripped, testing is then performed with the other half-wave.

```

ZLoop 2.46 Ω
┌───┴───┐
IK 93 A
└───┬───┘
UN 230V fN 50Hz
    
```

## 8.2 Evaluation of Measurement Values

The maximum allowable loop impedance  $Z_{Loop}$  which may be displayed after allowance has been made for maximum operating measurement error (under normal measuring conditions) can be determined with the help of Table 1 on page 71. Intermediate values can be interpolated.

The maximum allowable nominal current for the protective device (fuse or circuit breaker) for a line voltage of 230/240 V after allowance has been made for maximum measuring error can be determined with the help of Table 6 on page 73 based upon measured short-circuit current (corresponds to DIN VDE 0100 Part 610).



After measurement has been performed, allowable fuse types can be displayed by pressing the  $I_{\Delta N}$  / i key.

Char.	$I_A$	$t_A$ [s]	$I_N$ [A]
gG(gL)	$I_K$	<5.0	20
gG(gL)	$I_K$	<0.4	10
B/E(L)	$5 \cdot I_N$	<0.4 0.5	16
C(G/U)	$10 \cdot I_N$	<0.4 0.5	8
D	$20 \cdot I_N$	<0.4 0.5	4
K	$12 \cdot I_N$	<0.4 0.5	6



$I_A$  breaking current,  $I_K$  short-circuit current,  $I_N$  nominal current  
 $t_A$  time to trip < 0.4: current standard 2004 issue | 0.5: previous standard 1994 issue

The table shows maximum allowable nominal current dependent upon fuse type and breaking requirements.

## 8.3 Loop Impedance Measurement – Measurement via and without tripping the RCCB

Loop impedance L-PE can be determined with a nominal residual current of at least 30 mA with this function, even downstream from RCCBs. Measurement is performed for 2 seconds with a nominal residual current of 15 mA, and results are displayed with a typical accuracy of  $\pm 1 \Omega$ . The display range runs from 0.1  $\Omega$  to

99.9  $\Omega$ . Calculated short-circuit current is also displayed. Recommended fuse types do not appear at the display. If RCCBs are utilized, fuse values are determined based upon internal system resistance.

This measurement can be performed for system RCD protection where RCCBs up to 500 mA are utilized as protective devices, although, for example, loop resistance must be determined for purposes of documentation.

The measurement is sufficiently accurate for testing earth-fault loop impedances of less than 100  $\Omega$  (at 500 mA).



### Attention!

Earth-fault loop impedances of less than 1  $\Omega$  must be reliably substantiated for testing trip conditions with protective multiple earthing. Loop impedance measurement must be performed with the help of the PROFITEST®DC-II for testing purposes (see chapter 8.1).

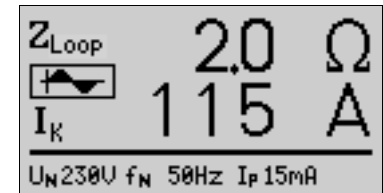
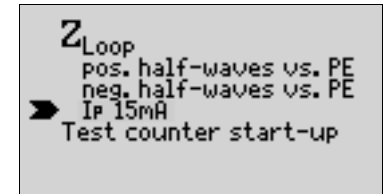
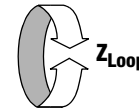

## 8.4 Testing Meter Start-Up with the Adapter

Start-up of energy consumption meters which are connected between L and L or L and N can be tested with this function.

### Set-Up

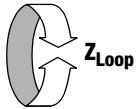
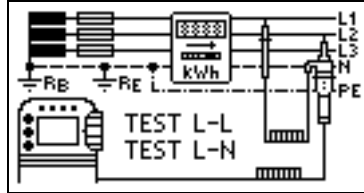

```

ZLoop
pos. half-waves vs. PE
neg. half-waves vs. PE
Ip 15mA
➔ Test counter start-up
    
```



### Attention!

Use only the 2-pole adapter and contact L1 (L2, L3) and N at the meter output.

Meters are tested with the help of an internal load resistor. After pressing the Start Key t (3), the meter can be tested for proper start-up within a period of 5 s. All phases must be tested against N, one after the other.



```

PTEST  ---  W
          RUN
-----
UN230V fN 50Hz
    
```

After testing has been completed, testing power is displayed. The instrument is now ready for further testing ("READY").



```

PTEST  56.8  W
          READY
-----
UN230V fN 50Hz
    
```



## 9 Measuring Supply Impedance (function $Z_I$ )

### Measuring Method

Supply impedance  $Z_I$  is measured by means of the same method used for loop impedance  $Z_{Loop}$  (see chapter 8, page 37). However, the current loop is completed via neutral conductor N rather than protective conductor PE as is the case with loop impedance measurement.



### Note

Measurement of supply impedance is only possible with the  $Z_{Loop}$  function if the Measuring Adapter (2-pole) (12) is attached!

### Set-Up

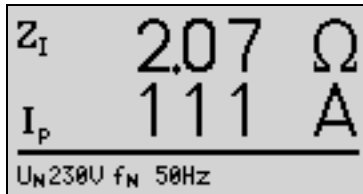
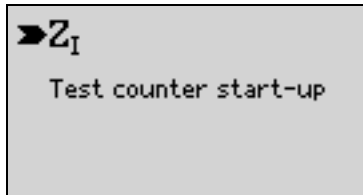
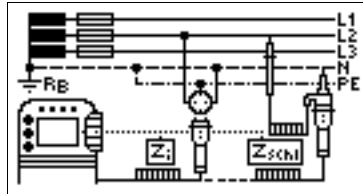
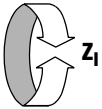

## 9.1 Testing Meter Start-Up with Earthing Contact Adapter

Start-up of energy consumption meters which are connected between L and N can be tested with this function.

### Set-Up

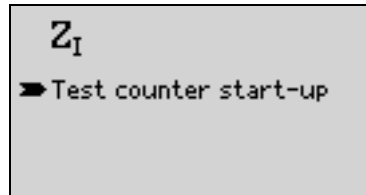
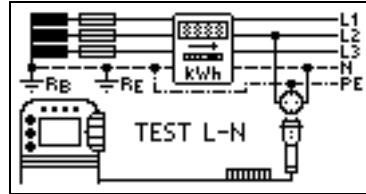
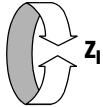

Meters are tested with the help of an internal load resistor. After pressing the Start Key t (3), the meter can be tested for proper start-up within a period of 5 s. All phases must be tested against N, one after the other.



After testing has been completed, testing power is displayed. The instrument is now ready for further testing ("READY").



## 10 Earthing Resistance Measurement (function $R_E$ )

Earthing resistance is the sum of earth electrode resistance ( $R_A$ ) and earth conductor resistance. Earthing resistance is measured by applying an alternating current via the earth conductor, the earth electrode and earth electrode resistance. This current, as well as voltage between the earth electrode and a probe, are measured.

The probe is connected to the Probe Connector Socket (20) with a 4 mm contact protected plug.

Direct measurement of earthing resistance  $R_E$  is only possible within a measuring circuit which includes a probe. However, this means that the probe and reference earth must be of like potential, i.e. that they are positioned outside of the earth electrode resistance area. The distance between the earth electrode and the probe should be at least 20 m.

In many cases, especially in extremely built-up areas, it is difficult, or even impossible, to set a measuring probe. In such cases, earthing resistance can be measured without a probe. In this case, however, the resistance values for the operational earth electrode  $R_B$  and phase conductor L are also included in the measurement results (see chapter 10.2 "Measuring without Probe" on page 45).

### Measuring Method

The instrument measures earthing resistance  $R_E$  by means of the ammeter-voltmeter test (earth electrode loop resistance). The test current which is applied to earthing resistance is controlled by the instrument and demonstrates the following values in the various measuring ranges:

0 to 10  $k\Omega$  - 4 mA, 0 to 1  $k\Omega$  - 40 mA, 0 to 100  $\Omega$  - 0.4 A and 0 to 10  $\Omega$  > 0.8 A to approx. 4 A (independent of voltage).

A voltage drop is generated which is proportional to earthing resistance.

Measuring range selection, and thus the selection of test current as well, are carried out automatically in the basic function. These selections can be made manually in the sub-functions.



### Note

Measurement cable and measuring adapter (12) resistance are compensated for automatically during measurement and have no effect on measurement results.

Interference voltages at protective conductor PE, at the earth electrode or at the probe (if properly connected) do not influence measurement results. They can be measured by means of voltage measurement (with the Measuring Adapter (2-pole) (12)).

If dangerous contact voltages occur during measurement (> 50 V), the measurement is interrupted and safety shut-down occurs.

Probe resistance does not effect measurement results and may be as high as 50  $k\Omega$ . If probe resistance is too high, measurement is automatically performed without the probe (see chapter 10.2 "Measuring without Probe" on page 45).

---



### Attention!

The probe is part of the measuring circuit and may carry a current of up to 3.5 mA in accordance with VDE 0413.

---

## 10.1 Measuring with Probe

### Set-Up

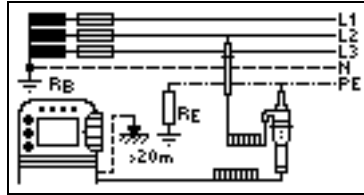

### 10.1.1 Automatic Measuring Range Selection

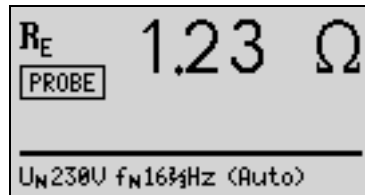

### 10.1.2 Manual Measuring Range Selection

Manual measuring range selection is provided for the measurement of earthing resistance in systems with RCCBs. Test current  $I_P$  at the instrument must be taken into consideration in order to avoid undesired tripping of the RCCB.

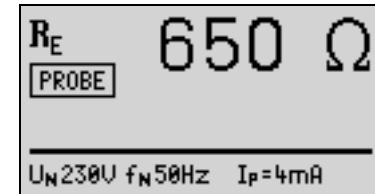
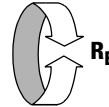

#### Note

When the measuring range is selected manually, accuracy values are only valid starting at 5% of the upper limit range value (except for the 10 Ω range; separate display for small values).

## 10.2 Measuring without Probe

In the event that it is impossible to set a probe, earthing resistance can be estimated by means of an “earth loop resistance measurement” without probe.

The measurement is performed exactly as described in chapter 10.1 “Measuring with Probe” starting on page 44. However, no probe is connected to the Probe Connector Socket (20).

The resistance value  $R_{ELOOP}$  obtained with this measuring method also includes operational earth electrode resistance and resistance at phase conductor L. These values must be deducted from the measured value in order to determine earthing resistance.

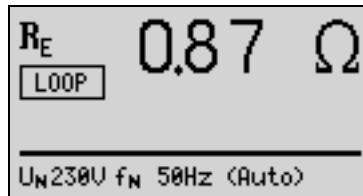

If conductors of equal cross section are assumed (phase conductor L and neutral conductor N), phase conductor resistance is half as great as supply impedance  $Z_1$  (phase conductor + neutral conductor).

Supply impedance can be measured as described in chapter 9 starting on page 41.

In accordance with DIN VDE 0100, the operational earth electrode  $R_B$  must lie within a range of “0 Ω to 2 Ω”.

Earthing resistance is determined with the following equation:

$$R_E = R_{ELOOP} - \frac{1}{2} \cdot R_L - R_B$$

The value for operational earth conductor resistance  $R_B$  should be ignored in the calculation of earthing resistance, because it is generally unknown.

The calculated earthing resistance thus includes operational earth conductor resistance as a safety factor.

## 10.3 Evaluation of Measurement Values

The maximum allowable displayed resistance values which assure that the required earthing resistance is not exceeded, and for which maximum device operating error has already been taken into consideration (at nominal conditions of use), can be determined with the help of Table 2 on page 71. Intermediate values can be interpolated.

## 10.4 Measuring Earth Electrode Potential (function U<sub>E</sub>)

This measurement is only possible with a probe. Earth electrode potential U<sub>E</sub> is the voltage which occurs at the earth electrode between the earth electrode terminal and reference earth if a short-circuit occurs between the phase conductor and the earth electrode. The measurement of earth electrode potential is required by Swiss standard SEV 3569.

### Measuring Method

In order to determine earth electrode potential the instrument first measures earth electrode loop resistance R<sub>ELOOP</sub>, and immediately thereafter earthing resistance R<sub>E</sub>. The instrument stores both values and then calculates earth electrode potential with the following equation:

$$U_E = \frac{U_N \cdot R_E}{R_{ELoop}}$$

The calculated value is displayed at the LC Display Field (1).

### Set-Up

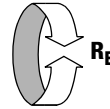
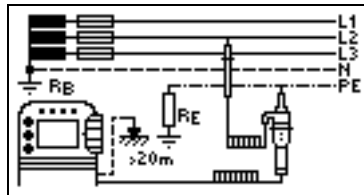

Probe defective

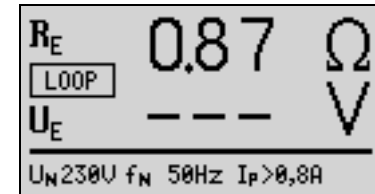
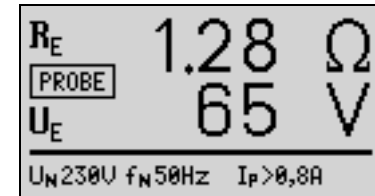

# 11 Measuring the Impedance of Insulating Floors and Walls (Standing Surface Insulation Impedance $Z_{ST}$ )

## Measuring Method

The instrument measures the impedance between a weighted metal plate and earth. The alternating voltage available at the measuring site is used as an alternating voltage source.

## Set-Up

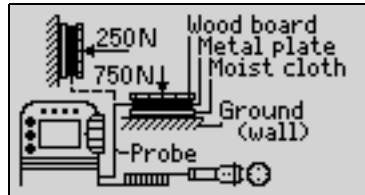

**Note:** Use the measuring set-up described in chapter 12.1 (triangular probe) or the one outlined below:

- ⇨ Cover the floor or the wall at unfavorable locations, e.g. at joints or abutments, with a damp cloth measuring approx. 270 mm x 270 mm.
- ⇨ Place a metal plate measuring approx. 250 mm x 250 mm x 2 mm on top of the damp cloth followed by a wooden board for purposes of insulation and a weight of 750 N/75 kg (one person), or for walls 250 N/25 kg (i.e. lean against the wall with one hand).
- ⇨ Establish a conductive connection between the metal plate and the Probe Connector Socket (20) at the instrument.
- ⇨ Connect the instrument to a mains outlet with the test plug.



### Attention!

Do not touch the metal plate or the damp cloth. Line voltage is present at these objects! A current of a great as 3.5 mA may be present!

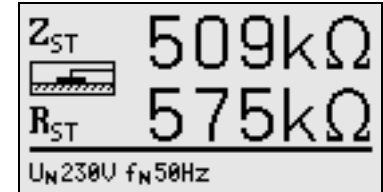
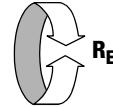

Resistance values must be measured at several points in order to provide for adequate evaluation. Measured resistance may not exceed 50 kΩ at any given point. If the measured resistance is greater than 1 MΩ,  $Z_{ST} > 999 \text{ k}\Omega$  appears at the LC Display Field (1).

**Note:** In addition to the standing surface insulation impedance  $Z_{ST}$  the resistive portion  $R_{ST}$  is also indicated.

## 12 Measuring Insulation Resistance (Function $R_{ISO}$ )

### Set-Up

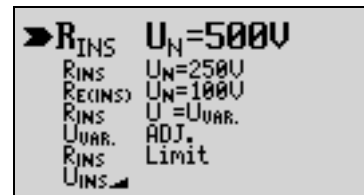
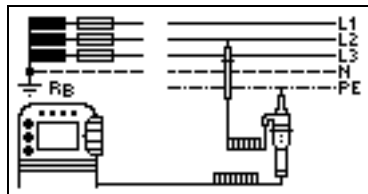

#### Note

If you use the test plug together with a plug insert, insulation resistance is only measured between the phase conductor terminal designated "L" and the protective conductor terminal PE!



#### Note

##### Checking the Measurement Cables

Before performing insulation measurement, the test probes on the measurement cables should be short-circuited in order to assure that the instrument displays a value very close to  $0 \Omega$ . In this way, incorrect connection can be avoided and broken measurement cables can be detected.



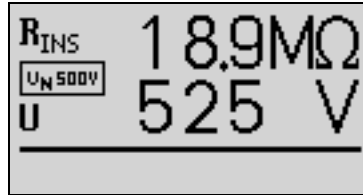

If measured insulation resistance is less than the selected limit value (see chapter 12.5), the  $U_L/R_L$  Lamp (7) lights up.



#### Note

Insulation resistance can only be measured at voltage-free objects.

If an interference voltage of  $\geq 10$  V is present within the system, insulation resistance is not measured. The NETZ/MAINS Lamp (6) lights up and a display appears at the LC Display Field (1), e.g.:

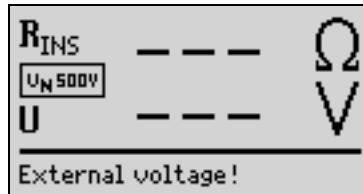

All conductors (L1, L2, L3 and N) must be tested against PE!



#### Attention!

Do not touch the instrument's terminal contacts during insulation resistance measurements!

If nothing has been connected to the terminal contacts, or if a resistive load component has been connected for measurement, your body would be exposed to a current of approx. 1 mA at a voltage of 500 V.

The resulting electrical shock is not life endangering. However, the noticeable shock may lead to injury (e.g. resulting from a startled reaction etc.).



#### Attention!

If measurement is performed at a capacitive object such as a long cable, it becomes charged with up to approx. 500 V!

**Touching such objects is life endangering!**

When an insulation resistance measurement has been performed on a capacitive object it is automatically discharged by the instrument after the Start Key ▼ (3 or 17) has been released. Contact between the object and the instrument may not be interrupted. The voltage decline can be observed directly at the LC Display Field (1).

**Do not disconnect the object until voltage has fallen below 25 V!**



#### Note

The instrument's batteries are exposed to excessive stress during insulation resistance measurement. Only hold the Start Key ▼ (3 or 17) depressed until the display has stabilized.

## 12.1 Measuring Earth Leakage Resistance (function $RE_{(ISO)}$ )

This measurement is performed in order to determine electrostatic discharge capacity for floor coverings in accordance with EN 1081.

### Set-Up

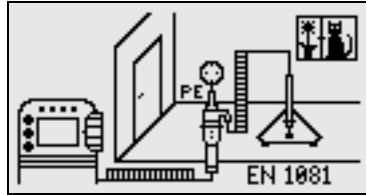

- ⇒ Rub the floor covering at the point at which measurement is to be performed with a dry cloth.
- ⇒ Place the floor probe 1081 onto the point of measurement and load it with a minimum weight of 300 N (30 kg).
- ⇒ Establish a conductive connection between the measuring electrode and the Test Probe (16) and connect the Measuring Adapter (2-pole) (12) to an earth contact, e.g. the earthing contact at a mains outlet or a central heating radiator.

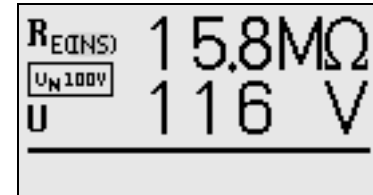
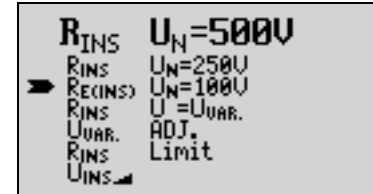

The limit value for earth leakage resistance from the relevant regulations applies.

## 12.2 Insulation Measurement with Selectable Test Voltage

A test voltage which deviates from, and is usually less than nominal voltage, can be selected under  $U_{VAR}$ . for measurements at sensitive components, as well as for systems with voltage limiting components. Selection can be made from 22 values ranging from 20 to 500 V. Select the test voltage with the  $I_{\Delta N}$  / i key.

The instrument can now be returned to the menu display by pressing the MENU key, or testing can be started for the  $R_{ISO}$  function ( $U=U_{VAR}$ ) by activating the START key.

### 12.3 Insulation Measurement with Rising Test Voltage

The “ $U_{ISO}$ ” function is used to detect weak points in the insulation, as well as to determine response voltage for voltage limiting components.

As long as the START key is held depressed, test voltage rises continuously. Insulation measurement is started:

- As soon as the upper voltage limit of 500 V has been reached or
  - As soon as the START key has been released (when the desired voltage appears at the display)
- or
- As soon as a measurable test current has been detected (e.g. after sparkover occurs at breakdown voltage).

Test voltage, any response and breakdown voltage which may be present and insulation resistance are displayed.

### 12.4 Evaluation of Measurement Values

Instrument measuring error must be taken into consideration in order to assure that the limit values set forth in DIN VDE regulations are not fallen short of. The required minimum display values for insulation resistance can be determined with the help of Table 3 on page 72. These values take maximum device error into consideration (under nominal conditions of use). Intermediate values can be interpolated.

### 12.5 Setting the Limit Value

The insulation resistance limit value can be set with the “ $R_{ISO}$  Limit” function. If measurement values occur which are below this limit value, the red  $U_L/R_L$  LED lights up. A selection of limit values ranging from 100 k $\Omega$  to 10 M $\Omega$  is available. Select the limit value with the  $I_{AN}$  / i key.

The instrument can be returned to the menu display by pressing the MENU key, or testing can be started with the basic function by activating the START key.



## 13 Measuring Low-Value Resistance of up to 100 $\Omega$ (protective conductor and bonding conductor)

### 13.1 Measuring Low-Value Resistance (function $R_{LO}$ )

According to the regulations, the measurement of low-value resistance at protective conductors, earth conductors or bonding conductors must be performed with (automatic) pole reversal of the test voltage, or with current flow in one (+ pole to PE) and the other direction (- pole an PE).



#### Attention!

Low-value resistance can only be measured at voltage-free objects.

#### Set-Up

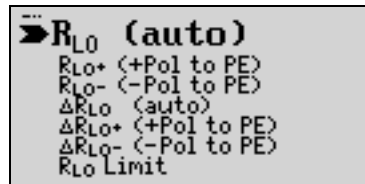
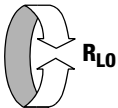
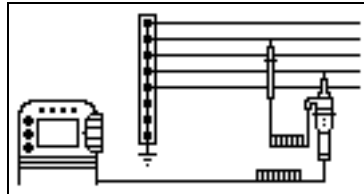

#### Attention!

The test probes should always be in contact with the DUT before the Start Key ▼ (3 or 17) is activated. If the object is charged with voltage, the measurement is blocked if the test probes are first placed into contact with the DUT, and the instrument fuse is blown if the Start Key ▼ is activated first.

After the measuring sequence has been started, the instrument performs measurement with automatic pole reversal, first with current flow in one direction, and then in the other. The largest measured resistance value is always displayed.

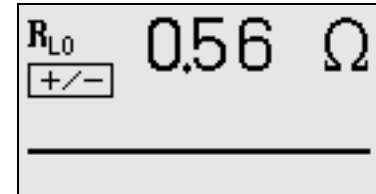

Differing results for measurements in both directions indicate voltage at the DUT (e.g. thermovoltages or unit voltages). In the case of major deviations between the two measured values, both values are displayed:

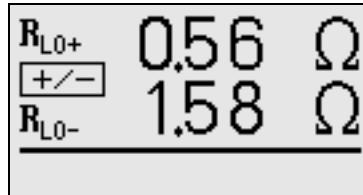

Measurement results can be distorted by parallel connected impedances at operating current circuits and by circulating current, especially in systems which make use of “overcurrent protection devices” (earlier neutralization) without an isolated protective conductor. Resistances which change during measurement (e.g. inductance), or a defective contact, can also cause distorted measurements (double display).

In order to assure unambiguous measurement results, causes of error must be located and eliminated.

#### Display for interference voltage, for example:

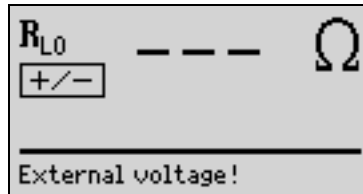

In order to find the cause of the measuring error, measure resistance in both current flow directions.

The instrument’s batteries are exposed to excessive stress during insulation resistance measurement. For measurement with current flow in one direction, only press and hold the Start Key ▼ (3 or 17) as long as is necessary for the measurement.



#### Note

#### Measuring Low-Value Resistance

Measurement cable and Measuring Adapter (2-pole) (12) resistance is compensated for automatically thanks to the four conductor method and do not effect measurement results. However, if an extension cable is used its resistance must be measured and deducted from the measurement results in accordance with chapter 13.2.

Resistances which do not demonstrate a stable value until after a “settling in period” should not be measured with automatic pole reversal. Measurement with automatic pole reversal may lead to varying and/or inflated measurement values, and thus to an ambiguous reading. Examples of resistances whose values may change during measurement include:

- Incandescent lamp resistance, whose values change due to warming caused by test current
- Resistances with a great conductive component
- Contact resistance

### 13.2 Compensation for Extension Cables of up to 10 $\Omega$ (function $\Delta R_{LO}$ )

If extension cables are used, their resistance can be deducted automatically from the measurement results. Proceed as follows:

- ⇒ Short-circuit the end of the measurement extension cable with the second test probe at the instrument.
- ⇒ Select one of the items under  $\Delta R_{LO}$  in the menu.
- ⇒ Initiate measurement with the Start Key.
- ⇒ After measurement has been completed, press the  $I_{\Delta N} / i$  key. The following message appears in the status line at the display:  $\Delta R_{LO}$  Offset xxx  $\Omega$ , where xxx is equal to a value between 0.00 and 9.99  $\Omega$ . This value will now be deducted from the actual measurement value for all subsequent  $\Delta R_{LO}$  measurements. Once the offset has been stored to memory, it remains even after the instrument has been switched off.



#### Note

Only use this function when taking measurements with an extension cable. Whenever different extension cables are used, the above described procedure must be repeated.

### 13.3 Calculation of Cable Lengths for Common Copper Conductors



If the  $I_{\Delta N} / i$  key is activated after performance of resistance measurement in accordance with chapter 13.1, the cable lengths corresponding to common conductor cross sections are displayed.

$\emptyset[\text{mm}^2]$	l[m]	$\emptyset[\text{mm}^2]$	l[m]
0.14	0.48	2.5	8
0.25	0.87	4.0	13
0.50	1.74	6.0	20
0.75	2.61	10.0	34
1.00	3.48	16.0	55
1.50	5.22	25.0	87

If results vary for the two different current flow directions, cable length is not displayed. In this case, capacitive or inductive components are apparently present which would distort the calculation.

This table only applies to cables made with commercially available copper conductors and cannot be used for other materials (e.g. aluminum)!

### 13.4 Setting the Limit Value

The resistance limit value can be set with the “R<sub>LO</sub> Limit” function. If measurement values which exceed this limit occur, the red U<sub>L</sub>/R<sub>L</sub> LED lights up. Limit values can be selected within a range of 0.10 Ω to 10 Ω. Select the desired limit value with the I<sub>AN</sub> / i key. The display returns to the menu when the MENU key is activated.

The instrument can be returned to the menu display by pressing the MENU key, or testing can be started with the basic function by activating the START key.

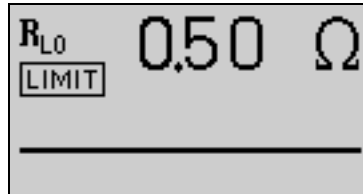

### 14 Phase Sequence Testing

#### Set-Up

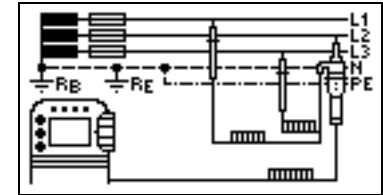

The Measuring Adapter (2-pole) (12) is required for connection of the instrument, and is expanded to a 3-pole measuring adapter with the included measurement cable.

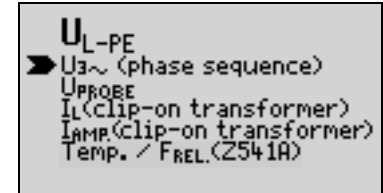
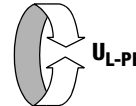

#### Note

- The following appear at the LC Display Field (1):
- Highest occurring voltage within the measuring circuit
  - All three phases displayed in order of their sequence represented by the numbers 1, 2, 3 (the numbers are separated by two periods)
  - A circle with an arrow, which indicates direction of rotation



Clockwise rotation

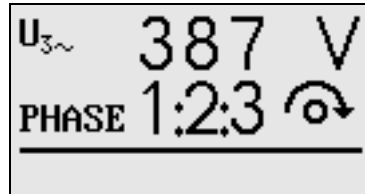

Counter-clockwise rotation

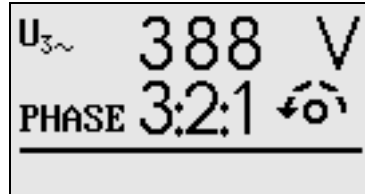

PE or N to phase

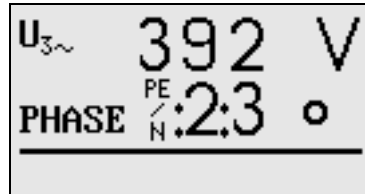

Phase missing

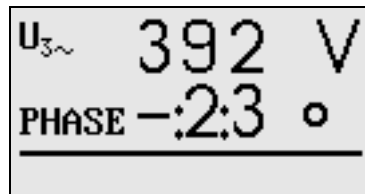



## 15 Operating and Display Elements

### (1) LC Display Field

The following are displayed at the LCD:

- One or two measurement values as three place numeric display with unit of measure and abbreviated measuring quantity
- Nominal values for voltage and frequency
- Circuit diagrams
- On-line help
- Messages and instructions

### (2) $I_{\Delta N}$ / i Key

The following sequences can be started with this key:

- Starts the tripping test after measurement of contact voltage for RCCB testing ( $I_{\Delta N}$ ).
- Displays the appropriate circuit diagram and on-line help after a function has been selected in the menu.
- Selects special RCCB tests (testing with positive or negative half-wave in IT systems).
- Displays information for  $Z_{Loop}$ ,  $Z_I$  and  $R_{LO}$  measurements.

This key has the same function as the I key (18).

### (3) Start Key ▼

This key starts the measuring sequence for the function which has been selected in the menu. If the instrument is off, it is switched on by pressing this key, and the measurement for the basic function or the pre-selected function is started.

In the functions  $R_{ISO}$  (insulation resistance),  $R_{LO+}$ ,  $R_{LO-}$  (bonding conductor resistance) and  $Z_{ST}$  (standing surface insulation impedance) measurement is performed until the key is released.

This key has the same function as the ▼ key (17).

### (4) Menu Key

The basic functions menu for the function selected with the Function Selector Switch (9) is called up with the yellow menu key, and the instrument is switched on at the same time, if it was off. Each additional activation of the key advances the arrow for the selection of one of the various functions.

### (5) PE Lamp

The PE lamp lights up red if a potential difference of greater than 100 V occurs between the Contact Surfaces (19) and the safety contact or terminal N at the Plug Insert (13), depending on the position of the Function Selector Switch (9) (see chapter 16.1 “Lamp Functions“ on page 66).



#### Note

The PE lamp might also light up if a potential transfer occurs during measurement. A potential transfer might occur if, for example, the Measuring Adapter (2-pole) (12) has been attached and you contact phase conductor L with the Test Probe (16) in one hand and touch a Contact Surface (19) at the Test Plug (14) with the other hand while standing on an insulated floor. In this case your body functions as a (capacitive) voltage divider.

### (6) NETZ/MAINS Lamp

This lamp is only functional when the instrument is switched on. It has no function in the voltage ranges  $U_{L-N}$  and  $U_{L-PE}$ .

It lights up green, red or orange, or blinks green or red depending upon how the instrument has been connected and the selected function (see chapter 16.1 “Lamp Functions“ on page 66).

This lamp also lights up if line voltage is present during measurement of  $R_{ISO}$  and  $R_{LO}$ .

### (7) $U_L/R_L$ Lamp

This lamp lights up red if contact voltage is greater than 25 V or 50 V during RCD testing, as well as after safety shut-down occurs. It also lights up if  $R_{ISO}$  or  $R_{LO}$  limit values have been exceeded or fallen short of.

### (8) FI/RCD Lamp

This lamp lights up red if the RCCB is not tripped within 400 ms (1000 ms for selective RCDs) during the tripping test with nominal residual current.

It also lights up if the RCCB is not tripped before nominal residual current has been reached during measurement with rising residual current.

If the “English/UK-parameter” has been selected, it also indicates RCD tripping at 50%  $I_{\Delta N}$ .

### (9) Function Selector Switch

The following basic functions can be selected with this rotary switch:

$U_{L-N} / U_{L-PE} / I_{\Delta N}$  (10 mA/30 mA/100 mA/300 mA/500 mA)  
 $Z_{Loop} / Z_1 / R_E / R_{ISO} / R_{LO}$

The various basic functions are selected by turning the function selector switch while the instrument is switched on.

### (10) Shoulder Strap

The included shoulder strap can be attached at the right and left hand sides of the instrument. You can hang the instrument from your shoulder and keep both hands free for measurement.

### (11) Test Plug Holder

The Test Plug (14) can be stored in the holder at the instrument along with the attached Plug Insert (13).

### (12) Measuring Adapter



#### Attention!

The Measuring Adapter (2-pole) (12) may only be used together with the Test Plug (14) included with the **PROFITEST 0100S-II+**. Use for other purposes is prohibited!

The plug-on Measuring Adapter (2-pole) (12) is used together with the two test probes (16) for measurements in systems without earthing contact outlets, e.g. at permanent installations, distribution cabinets and all three-phase outlets, as well as for insulation resistance and low-value resistance measurements.

The 2-pole measuring adapter can be expanded to three poles for phase sequence testing with the included measurement cable (test probe).

### (13) Plug Insert (country specific)



#### Attention!

The Plug Insert (13) may only be used with the Test Plug (14) included with the **PROFITEST 0100S-II+**. Use for other purposes is prohibited!

After the plug insert has been attached, the instrument can be directly connected to earthing contact outlets. You need not concern yourself with poling at the plug. The instrument detects the positions of phase conductor L and neutral conductor N and automatically reverses poles if necessary.



#### Note

No automatic polarity reversal occurs if the “English/UK-parameter” has been selected in setup.

The instrument automatically determines whether or not both protective contacts in the earthing contact outlet are connected to one another, as well as to the system protective conductor, for all types of protective conductor measurements when the plug insert is attached to the Test Plug (14).

#### **(14) Test Plug**

The various country specific plug inserts (e.g. protective contact plug insert for Germany or SEV plug insert for Switzerland) or the Measuring Adapter (2-pole) (12) are attached to the test plug and secured with a threaded connector.

#### **(15) Alligator Clip (plug-on)**

#### **(16) Test Probes**

The test probes comprise the second (permanently attached) and third (plug-on) poles of the Measuring Adapter (12). A coil cable connects them to the plug-on portion of the measuring adapter.

#### **(17) ▼ Key**

This key has the same function as the Start Key ▼ (3).

#### **(18) Taste I**

This key has the same function as the  $I_{\Delta N}$  / i key (2).

#### **(19) Contact Surfaces**

The contact surfaces are located at both sides of the Test Plug (14). When the contact plug is grasped in the hand, contact is automatically made with these surfaces. The contact surfaces are electrically isolated from the terminals and from the measuring circuit. The instrument can be used as a phasing tester for protection class II devices!

If a potential difference of greater than 100 V occurs between the protective conductor terminal PE and the contact surface, the PE Lamp (5) lights up (see chapter 16.1 "Lamp Functions" on page 66).

#### **(20) Probe Connector Socket**

The probe connector socket is required for the measurement of probe voltage  $U_{S-PE}$ , earth electrode voltage  $U_E$ , earthing resistance  $R_E$  and standing surface insulation resistance.

It can be used for the measurement of contact voltage during RCD testing. The probe is connected with a 4 mm contact protected plug.

The instrument determines whether or not the probe has been properly set and displays results at the LC Display Field (1).

#### **(21) Strap Eyelets**

Strap eyelets are located at the left and right hand sides of the instrument. A strap or a belt can be passed through these eyelets for strapping the instrument to the operator's body.

#### **(22) Swivel Hinge**

The display and control field can be swiveled forward or backward with the detented swivel hinge. The instrument can thus be set to the optimum reading angle.

### (23) Replacement Fuses

Two replacement fuses are located beneath the Battery Compartment Lid (28).

### (24) Fuses

The two type M 3.15/500G fuses (safety fuse FF 3.15/500G) protect the instrument against overload. Phase conductor L and neutral conductor N are fused individually. If a fuse is defective, and if an attempt is made to perform a measurement which uses the circuit protected by this fuse, a corresponding message appears at the LC Display Field (1).



#### Attention!

**Severe damage to the instrument may occur if incorrect fuses are used.**

Only original fuses from GMC-I Messtechnik GmbH assure required protection by means of suitable blowing characteristics (order no. 3-578-189-01).

---



#### Note

Voltage ranges  $U_{L-N}$  and  $U_{L-PE}$  remain functional even if fuses have blown.

---

### (25) Fold-Out Stand

The fold-out stand provides the adjustable control and display field with a more secure stance.

The fold-out stand should be used especially when the instrument is operated flat on a test bench with the optional SI module **PROFI-TEST | SI-BC** attached to the top.

### (26) Serial Plate

The serial plate includes information concerning the functions, as well as the instrument's characteristic values.

### (27) Battery Holder

The battery holder is designed for use with six 1.5 V mignon cells in accordance with IEC LR 6 for power supply to the instrument. Make certain that the batteries are poled in accordance with the symbols when inserting new batteries.

The holder can only be inserted into the battery compartment in its proper position.

### (28) Battery Compartment Lid



#### Attention!

When the lid is removed, the instrument must be disconnected from the measuring circuit at all poles!

---

The battery compartment lid covers the Battery Holder (27) with the batteries, the Fuses (24) and the Replacement Fuses (23).

**(29) Measurement Value 1, Abbreviated**

**(30) Abbreviation for Selected Sub-Function**

**(31) Three Place Numeric Display: Measurement Value 1**

with unit of measure

**(32) Three Place Numeric Display: Measurement Value 2**

with unit of measure

**(33) Abbreviation**

for selected sub-function, messages and help

**(34) Measurement Value 2, Abbreviated**

**(35) Charging Socket / Current Transformer Connector Jack**

This socket may **only** be used for connection of the battery charger for recharging batteries in the instrument or the Z501G clip-on current transformer.

**(36) Infrared Interface (SIR, IrDa)**

Data are transmitted to the SI module (accessory) via this interface for storage and the generation of reports. An IrDa adapter (accessory) can also be connected in order to update instrument software with the help of a PC.

# 16 Characteristic Values

Function	Measuring Quantity	Display Range	Resolution	Input Impedance/ Test Current	Measuring Range	Nominal Values	Operating Error	Inherent Error	Connections							
									Plug Insert <sup>2)</sup>	2-Pole Adapter	3-Pole Adapter	Probe	Clip	Z541 A		
U <sub>L-PE</sub>	U <sub>L-PE</sub>	0 ... 99.9 V 100 ... 500 V	0.1 V 1 V	Terminal L-N-PE 500 kΩ	108 ... 253 V		±(2% rdg. + 1 d)	±(1% rdg.+ 5 d) ±(1% rdg.+ 1 d)	●	●						
		0 ... 99.9 V 100 ... 500 V	0.1 V 1 V		108 ... 500 V <sup>6)</sup>			±(1% rdg.+ 5 d) ±(1% rdg.+ 1 d)								
	f	15.0 ... 99.9 Hz 100 ... 1000 Hz	0.1 Hz 1 Hz	Terminal L-PE 500 kΩ	15.4 ... 420 Hz		±(0.2% rdg. + 1 d)	±(0.1% rdg. + 1 d)								
	U <sub>3-</sub>	0 ... 99.9 V 100 ... 500(850 <sup>1)</sup> ) V	0.1 V 1 V		108 ... 500 V <sup>6)</sup>		±(3% rdg. + 1 d)	±(2% rdg.+ 1 d)								
	U <sub>Probe</sub>	0 ... 99.9 V 100 ... 253 V	0.1 V 1 V	Probe-PE 1MΩ	0 ... 253 V		±(3% rdg. + 5 d)	±(2% rdg.+ 4d)							●	
	I <sub>L</sub>	0 ... 1 A	0.1 mA		5 mA ... 1.0 A		±(5% rdg. + 5 d)	±(3% rdg.+ 3 d)								●
	I <sub>AMP.</sub>	0 ... 99.9 A 100 ... 199 A	0.1 A 1 A		10 A ... 150 A		±(10% rdg.+5d)	±(5% rdg.+3d)								●
T <sup>4)</sup> F <sub>rel</sub> <sup>4)</sup>	-10,0 ... +50,0 °C			0 ... +40 °C 20 ... 80%			±2 °C ±5%			●						
U <sub>L-N</sub>	U <sub>L-N</sub>	0 ... 99.9 V 100 ... 300 V	0.1 V 1 V	330 kΩ	108 ... 253 V		±(2% rdg. + 1 d)	±(1% rdg.+ 5 d) ±(1% rdg.+ 1 d)	●							
	f	15.0 ... 99.9 Hz 100 ... 1000 Hz	0.1 Hz 1 Hz		15.4 ... 420 Hz		±(0.2% rdg. + 1 d)	±(0.1% rdg. + 1 d)								
I <sub>ΔN</sub>	U <sub>ΔN</sub>	0 ... 70.0 V	0.1 V	0.3 · I <sub>ΔN</sub>	5 ... 70 V		+10% rdg. + 1 d	+1% rdg. -1 d ... +9% rdg. + 1 d	●	●						
	R <sub>E</sub> / I <sub>ΔN</sub> = 10 mA	10 Ω ... 6.51 kΩ	10 Ω		value calculated from U <sub>ΔN</sub> /I <sub>ΔN</sub>	U <sub>N</sub> = 120/230 V f <sub>N</sub> = 50/60 Hz U <sub>L</sub> = 25/50 V										
	R <sub>E</sub> / I <sub>ΔN</sub> = 30 mA	3 Ω ... 999 Ω 1 kΩ ... 2.17 kΩ	3 Ω 10 Ω													
	R <sub>E</sub> / I <sub>ΔN</sub> = 100mA	1 Ω ... 651 Ω	1 Ω													
	R <sub>E</sub> / I <sub>ΔN</sub> = 300mA	0.3 Ω ... 99.9 Ω 100 Ω ... 217 Ω	0.3 Ω 1 Ω													
	R <sub>E</sub> / I <sub>ΔN</sub> = 500mA	0.2 Ω ... 9.99 Ω 100 Ω ... 130 Ω	0.2 Ω 1 Ω													
	I <sub>Δ</sub> / I <sub>ΔN</sub> = 10 mA	3.0 ... 13.0 mA	0.1 mA	3.0 ... 13.0 mA	3.0 ... 13.0 mA	I <sub>ΔN</sub> = 10/30/ 100/300/500 mA										
	I <sub>Δ</sub> / I <sub>ΔN</sub> = 30 mA	9.0 ... 39.0 mA		9.0 ... 39.0 mA	9.0 ... 39.0 mA											
	I <sub>Δ</sub> / I <sub>ΔN</sub> = 100 mA	30 ... 130 mA	1 mA	30 ... 130 mA	30 ... 130 mA											
	I <sub>Δ</sub> / I <sub>ΔN</sub> = 300mA	90 ... 390 mA	1 mA	90 ... 390 mA	90 ... 390 mA											
	I <sub>Δ</sub> / I <sub>ΔN</sub> = 500mA	150 ... 650 mA	1 mA	150 ... 650 mA	150 ... 650 mA											
	U <sub>Δ</sub> / U <sub>L</sub> = 25 V	0 ... 25.0 V	0.1 V	same as I <sub>Δ</sub>	0 ... 25.0 V	U <sub>N</sub> <sup>2)5)</sup> = 400 V										
	U <sub>Δ</sub> / U <sub>L</sub> = 50 V	0 ... 50.0 V			0 ... 50.0 V										+10% rdg. + 1 d	+2.5% rdg. -1d +9% rdg. + 1 d
t <sub>A</sub> / I <sub>ΔN</sub>	0 ... 1000 ms	1 ms	1.05 · I <sub>ΔN</sub>	0 ... 1000 ms		±4 ms	±3 ms	option ally								
t <sub>A</sub> / 5 · I <sub>ΔN</sub>	0 ... 40 ms	1 ms	5 · I <sub>ΔN</sub>	0 ... 40 ms	I <sub>ΔN</sub> = 10/30 mA											

Function	Measuring Quantity	Display Range	Resolution	Input Impedance/ Test Current	Measuring Range	Nominal Values	Measuring uncertainty	Instinsic uncertainty	Connections					
									Plug, Insert <sup>2)</sup>	2-Pole Adapter	3-Pole Adapter	Probe	Clip	Z541 A
Z <sub>Loop</sub>	Z <sub>Loop</sub> (full waves)	0.01 ... 9.99 Ω	10 mΩ	0.83 ... 4.0 A	0.15 ... 0.49 Ω	U <sub>N</sub> = 120/230 V	±(10% rdg. + 2d)	±3 d	●	●	●			
	Z <sub>i</sub>				0.50 ... 0.99 Ω		±(10% rdg. + 3d)	±(4% rdg. + 3d)						
	Z <sub>i</sub> (+/- half-waves)	1.0 ... 9.99 Ω	±(5% rdg. + 3d)	±(3% rdg. + 3d)										
	I <sub>k</sub>	0 A ... 999 A 1,00 kA ... 9,99 kA 10,0 kA ... 50,0 kA <sup>3)</sup>	1 A 10 A 100 A	—	120 (108 ... 132) V 230 (196 ... 253) V 400 (340 ... 440) V	f <sub>N</sub> = 50/60 Hz	value calculated from Z <sub>Loop</sub>							
R <sub>E</sub>	R <sub>E</sub> (R <sub>E,Loop</sub> without probe)	0 ... 10 Ω	10 mΩ	0.83 ... 3.4 A	0.15 Ω ... 0.49 Ω	U <sub>N</sub> = 120/230 V U <sub>N</sub> = 400 V <sup>2)</sup> f <sub>N</sub> = 50/60 Hz	±(10% rdg. + 2d)	±3 d	●	●	●			
		0 ... 10 Ω	10 mΩ	0.83 ... 3.4 A	0.50 Ω ... 0.99 Ω		±(10% rdg. + 3d)	±(4% rdg. + 3d)						
		0 ... 10 Ω	10 mΩ	0.83 ... 3.4 A	1.0 Ω ... 9.99 Ω		±(5% rdg. + 3d)	±(3% rdg. + 3d)						
	0 ... 100 Ω	10 mΩ	400 mA	10 Ω ... 99.9 Ω	±(10% rdg. + 3d)		±(3% rdg. + 3d)							
	U <sub>E</sub>	0 ... 253 V	1 V	—	calculated value									
	Z <sub>ST</sub>	0 ... 1 MΩ	1 kΩ	2.3 mA at 230 V	10 kΩ ... 199 kΩ	U <sub>0</sub> = U <sub>L-N</sub>	±(10% rdg. + 2d)	±(5% rdg. + 3d)						
	R <sub>ST</sub>				200 kΩ ... 999 kΩ		±(20% rdg. + 2d)	±(10% rdg. + 3d)						
R <sub>ISO</sub>	R <sub>ISO</sub> , R <sub>E,ISO</sub>	0.01 ... 9.99 MΩ	10 kΩ	I <sub>k</sub> = 1.5 mA	50 kΩ ... 100 MΩ	U <sub>N</sub> = 100 V I <sub>N</sub> = 1 mA	±(5% rdg. + 1d)	±(3% rdg. + 1d)	●	●				
		10.0 ... 99.9 MΩ	100 kΩ											
		100 ... 200 MΩ	1 MΩ											
		U	25 ... 600 V-	1 V	500 kΩ	25 ... 600 V		±(3% rdg. + 1d)	±(1.5% rdg. + 1d)					
R <sub>LO</sub>	R <sub>LO</sub>	0.01 Ω ... 9.99 Ω	10 mΩ	I <sub>m</sub> ≥ 200 mA	0.1 Ω ... 6 Ω	U <sub>0</sub> = 4.5 V	±(4% rdg. + 2d)	±(2% rdg. + 2 d)		●				

1) Only for systems with overvoltage category II, contamination factor 2, max. 5 minutes

2) U > 253 V with 2-pole adapter only

3) 100 U<sub>N</sub> x 1/Ω

4) with external adapter Z541A as accessory

5) I<sub>ΔN</sub> = 500 mA, max. U<sub>N</sub> = 250 V

6) L-P: 300 V, L-L: 500 V

### Reference Conditions

Line Voltage	230 V $\pm$ 0.1 %
Line Frequency	50 Hz $\pm$ 0.1 %
Meas. Quantity Frequency	45 Hz ... 65 Hz
Meas. Quantity Waveform	sine (deviation between effective and rectified value $\leq$ 0.1%)
Line Impedance Angle	$\cos \varphi = 1$
Probe Resistance	$\leq 10 \Omega$
Supply Voltage	battery: 8 V $\pm$ 0.5 V

Ambient Temperature	+ 23 °C $\pm$ 2 K
Relative Humidity	40 % ... 60 %
Contact Finger	for testing potential diff. at earth
Standing Surface Insulation	resistive only

### Nominal Ranges of Use

Voltage $U_N$	120 V	(108 ... 132 V)
	230 V	(196 ... 253 V)
	400 V	(340 ... 440 V)
Frequency $f_N$	16 $\frac{2}{3}$ Hz	(15.4 ... 18 Hz)
	50 Hz	(49.5 ... 50.5 Hz)
	60 Hz	(59.4 ... 60.6 Hz)
	200 Hz	(190 ... 210 Hz)
	400 Hz	(380 ... 420 Hz)
Overall Voltage Range $U_Y$	65 ... 550 V	
Overall Frequency Range	15.4 ... 420 Hz	
Waveform	sine	
Temperature Range	0 °C ... + 40 °C	
Battery Voltage	6 ... 10 V	
Line Impedance Angle	corresponds to $\cos \varphi = 1 \dots 0.95$	
Probe Resistance	< 50 k $\Omega$	

### Ambient Conditions

Storage Temperature	-20 °C ... +60 °C (without batteries)
Operating Temperature	-10 °C ... +50 °C
Relative Humidity	max. 75%, no condensation
Elevation	max. 2000 m

### Power Supply

Batteries	6 ea. 1.5 V mignon cell (alkaline manganese per IEC-LR6 (or ANSI-AA or JIS-AM3)
Rechargeable Batteries	NiCd or NiMH
battery charger (not included)	NA 0100S (9 V DC) jack plug, 3.5 mm dia.
Charging Time	approx. 8 hours

### Number of Measurements (with one set of batteries), without illumination

$R_{ISO}$	1 measurement – 25 s pause: 1500 measurements
$R_{LO}$	automatic pole reversal (1 measuring cycle) – 25 s pause: 1500 measurements

Due to the minimum capacity of rechargeable batteries as compared to standard batteries, a fewer number of measurements indicated above can be performed with rechargeable batteries. By means of the 0100S rechargeable battery set (order no. Z501B)  $\frac{2}{3}$  of the number of measurements indicated above can be performed.



## Electricity Safety

Safety Class	II per IEC 61010-1/EN 61010-1/ VDE 0411-1
Nominal Voltage	230/400 V (300/500 V)
Test Voltage	3.7 kV 50 Hz
Measuring Category	300 V CAT III
Contamination Degree	2
Fusing	
Terminals L and N	1 cartridge fuse-link ea. M 3.15/500G 6.3 mm x 32 mm (safety fuse FF 3.15/500G)

## Electromagnetic Compatibility (EMC)

Interference emission	EN 61326-1: 2006 class A
Interference immunity	EN 61326-1: 2006

## Overload Capacity

$R_{ISO}$	600 V continuous
$U_{L-PE}, U_{L-N}$	600 V continuous
$F_i, R_E, R_F$	440 V continuous
$Z_{Loop}, Z_i$	550 V (limits the number of measurements and pause duration. If overload occurs, the instrument is switched off by means of a thermostatic switch)
$R_{LO}$	Electronic protection prevents switching on if interference voltage is present
Fine Wire Fuse Protection	3.15 A 10 s, fuses blow at > 5 A

## Data Interface

Type	infrared interface (SIR/IrDa) bidirectional, half-duplex transmission
Format	9600 baud, 1 start bit, 1 stop bit, 8 data bits, no parity, no handshake
Range	max. 30 cm recommended distance: < 10 cm

## Mechanical Design

Dimensions	240 mm x 340 mm x 62 mm (without measurement cables)
Weight	approx. 2.5 kg with batteries
Protection	housing: IP 40, test probe: IP 40 per DIN VDE 0470 Part 1/EN 60529

Extract from table on the meaning of IP codes

IP XY (1 <sup>st</sup> digit X)	Protection against foreign object entry	IP XY (2 <sup>nd</sup> digit Y)	Protection against the penetration of water
0	not protected	0	not protected
1	≥ 50.0 mm Ø	1	vertically falling drops
2	≥ 12.5 mm Ø	2	vertically falling drops with enclosure tilted 15°
3	≥ 2.5 mm Ø	3	spraying water
4	≥ 1.0 mm Ø	4	splashing water

## 16.1 Lamp Functions

Lamp	Status	Test Plug	Meas. Adapter	Function Selector Switch Position (9)	Function
PE	lights up red	X	X	all	<b>Instrument off</b> and potential difference $\geq 100$ V between contact finger and one of terminals L, N, PE or L1, L2, L3 with single-pole connection or PE (earthing contact) with multi-pole connection, frequency $f > 45$ Hz
PE	lights up red	X	X	$I_{\Delta N} / R_E / R_{LO} / Z_{Loop} / R_{ISO}$	<b>Instrument on</b> and potential difference $\geq 100$ V between contact finger and PE (earthing contact), frequency $f > 45$ Hz
NETZ/ MAINS <sup>1)</sup>	lights up green	X		$I_{\Delta N} / R_E / R_I / Z_{Loop}$	Line voltage of 65 V to 253 V, measurement can be performed
NETZ/ MAINS <sup>1)</sup>	blinks green		X	$I_{\Delta N} / R_E / R_I / Z_{Loop}$	Line voltage of 65 V to 440 V, N conductor not connected, measurement can be performed ( $I_{\Delta N}$ 500 mA, 330 V)
NETZ/ MAINS	blinks green		X	$Z_{Loop}$	Line voltage of 65 V to 550 V, measurement can be performed
NETZ/ MAINS <sup>1)</sup>	lights up orange	X		$I_{\Delta N} / R_E / Z_I / Z_{Loop}$	Line voltage of 65 V to 253 V to PE, 2 different phases active (no N conductor at mains), measurement can be performed
NETZ/ MAINS <sup>1)</sup>	blinks red	X		$I_{\Delta N} / R_E / Z_I / Z_{Loop}$	Line voltage of $< 65$ V or $> 253$ V, measurement blocked
NETZ/ MAINS	blinks red		X	$Z_{Loop}$	Line voltage of $< 65$ V or $> 550$ V, measurement blocked
NETZ/ MAINS	lights up red		X	$R_{ISO} / R_{LO}$	Interference voltage detected, measurement blocked
$U_L/R_L$	lights up red	X	X	$I_{\Delta N}$ $R_{ISO} / R_{LO}$	– Contact voltage $U_{I\Delta N}$ or $U_{I\Delta}$ $> 25$ V respectively $> 50$ V – Safety shut-down has occurred – Limit value exceeded or fallen short of for $R_{ISO} / R_{LO}$ function
FI/RCD	lights up red	X	X	$I_{\Delta N}$	The RCCB was not tripped, or was tripped too late during the tripping test; the RCD tripped at 50 % with „English/UK-parameter“

<sup>1)</sup> The NETZ/MAINS Lamp (6) has no function during testing for residual current devices (RCDs) in IT systems.

# 17 Maintenance

## 17.1 Self-Test

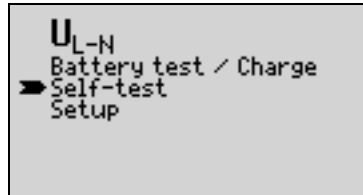
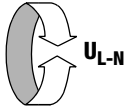

### Note

The following information is displayed at the test window:

- Software version with date of issue
- Instrument type
- Date of last calibration / last balancing
- Status display for internal testing ("OK!" must appear at the ROM and CAL-CHECK SUM display. If OK is not displayed, the measuring and test instrument may no longer be used for the performance of measurements. Please contact your nearest customer service center.

In order to run all of the tests, press the Start Button ▼ (3 or 17) after each test window appears at the display.

The self-test can be interrupted after any given test window has appeared by pressing the Menu Key (4).

Six different test windows appear at first with horizontal and vertical lines, e.g.:

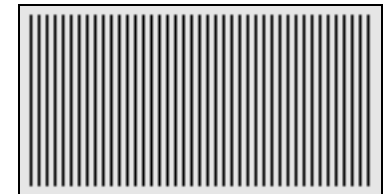

Subsequently, the following test windows are displayed:

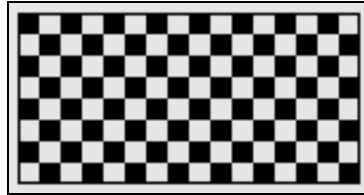

**Note**

Each of the four indicated lamps blinks three times.  
The PE lamp cannot be tested automatically!

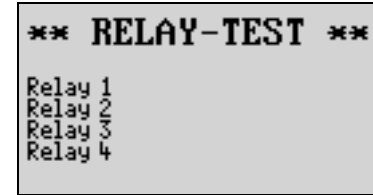

**Note**

Each of the indicated relays is actuated twice.

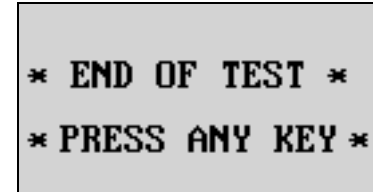

The measuring and testing instrument is restarted  
by pressing any key.

## 17.2 Battery and Rechargeable Battery Operation, and Charging

Check to make sure that no leakage has occurred at batteries or rechargeable batteries at short, regular intervals, or after the instrument has been in storage for a lengthy period of time. If leakage has occurred, the electrolyte must be carefully and completely removed with a damp cloth and new batteries must be installed before the instrument is placed back into operation.

If the battery test indicates that battery voltage has fallen below the minimum allowable value (see chapter 3.3 “Battery Test” on page 9), install a new set of batteries or charge the rechargeable batteries (see chapter 3.1 “Installing or Replacing Batteries” on page 8).

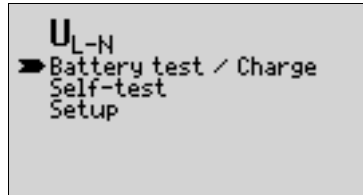
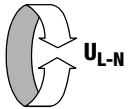

### Attention!

Use only the NA 0100S battery charger with reliable electrical isolation and a nominal secondary value of 9 V DC for the recharging of batteries. Before connecting the charger to the charging socket make certain that:

- Rechargeable batteries have been installed (not standard batteries)

- The instrument has been disconnected from the measuring circuit at all poles
- The voltage selector at the charger is set to 9 V

### 17.2.1 Initial Charging of NiMH or NiCd Batteries in the Test Instrument

#### Problem

The rechargeable battery pack cannot be charged:

- The first time the battery pack is charged
- When a battery pack is charged which includes batteries which have been charged to greatly varying levels.

This can be recognized by the fact that after approximately 30 minutes of charging with the test instrument switched off, a dead battery is indicated when the instrument is switched back on, and it switches itself immediately back off.

#### Remedy

- Disconnect the battery charger from the mains outlet and from the test instrument.
- Turn the voltage selector switch at the battery charger from the “9 V” position to the “12 V” position.
- Connect the battery charger to the test instrument, and then to the 230 V mains outlet.
- Charge the battery pack for 10 to 15 minutes with the test instrument switched off.
- Disconnect the battery charger from the mains outlet and turn the voltage selector switch from the “12 V” position back to the “9 V” position.
- Reconnect the battery charger to the 230 V mains outlet.
- Continue recharging the battery pack.

## 17.3 Fuses

If a fuse has blown due to overload, a corresponding message error appears at the LC Display Field (1). The instrument's voltage measuring ranges are nevertheless still functional.



### Note

Blown fuses cannot be detected when the instrument is set to certain functions. In such cases, the following message appears at the display: "Check test setup". There are many possible causes, amongst others a blown fuse.

## Replacing Fuses



### Attention!

Disconnect the instrument from the measuring circuit at all poles before opening Battery Compartment Lid (28)!

- ⇨ Loosen the slotted screw at the Battery Compartment Lid (28) at the back of the instrument and remove the lid. Fuses (24) and Replacement Fuses (23) are now accessible.
- ⇨ Open the fuse closure with the help of an appropriate tool (e.g. a screwdriver) by pressing and turning counter-clockwise.



### Attention!

**Severe damage to the instrument may occur if incorrect fuses are used.**

Only original fuses from GMC-I Messtechnik GmbH assure required protection by means of suitable blowing characteristics (order no. 3-578-189-01).

Short-circuiting of fuse terminals of the repair of fuses is prohibited!

The instrument may be damaged if fuses with incorrect ampere ratings, breaking capacities or blowing characteristics are used!

- ⇨ Remove the defective fuse and insert a Replacement Fuses (23).
- ⇨ Insert the fuse closure after the fuse has been replaced and secure by turning clockwise.
- ⇨ Replace the Battery Compartment Lid (28) and retighten the screw.

## 17.4 Housing

No special maintenance is required for the housing. Keep outside surfaces clean. Use a slightly dampened cloth for cleaning. Avoid the use of cleansers, abrasives or solvents.

## 17.5 Device Return and Environmentally Compatible Disposal

The instrument is a category 9 product (monitoring and control instrument) in accordance with ElektroG (*German Electrical and Electronic Device Law*). This device is not subject to the RoHS directive.

We identify our electrical and electronic devices (as of August 2005) in accordance with WEEE 2002/96/EG and ElektroG with the symbol shown to the right per DIN EN 50419 .



These devices may not be disposed with the trash. Please contact our service department regarding the return of old devices.

## 18 Appendix

Tables for the determination of maximum or minimum display values under consideration of maximum instrument operating error:

### 18.1 Table 1

$Z_{\text{Loop}} \text{ (full wave)} / Z_1 \text{ } (\Omega)$		$Z_{\text{Loop}} \text{ (+/- half-wave)} (\Omega)$	
Limit Value	Max. Display Value	Limit Value	Max. Display Value
0.10	0.07	0.10	0.05
0.15	0.11	0.15	0.10
0.20	0.16	0.20	0.14
0.25	0.20	0.25	0.18
0.30	0.25	0.30	0.22
0.35	0.30	0.35	0.27
0.40	0.34	0.40	0.31
0.45	0.39	0.45	0.35
0.50	0.43	0.50	0.39
0.60	0.51	0.60	0.48
0.70	0.60	0.70	0.56
0.80	0.70	0.80	0.65
0.90	0.79	0.90	0.73
1.00	0.88	1.00	0.82
1.50	1.40	1.50	1.33
2.00	1.87	2.00	1.79
2.50	2.35	2.50	2.24
3.00	2.82	3.00	2.70
3.50	3.30	3.50	3.15
4.00	3.78	4.00	3.60
4.50	4.25	4.50	4.06
5.00	4.73	5.00	4.51
6.00	5.68	6.00	5.42
7.00	6.63	7.00	6.33
8.00	7.59	8.00	7.24
9.00	8.54	9.00	8.15
9.99	9.48	9.99	9.05

### 18.2 Table 2

		$R_E / R_{E\text{Loop}} (\Omega)$			
Limit Value	Max. Display Value	Limit Value	Max. Display Value	Limit Value	Max. Display Value
0.10	0.07	10.0	9.49	1.00 k	906
0.15	0.11	15.0	13.6	1.50 k	1.36 k
0.20	0.16	20.0	18.1	2.00 k	1.81 k
0.25	0.20	25.0	22.7	2.50 k	2.27 k
0.30	0.25	30.0	27.2	3.00 k	2.72 k
0.35	0.30	35.0	31.7	3.50 k	3.17 k
0.40	0.34	40.0	36.3	4.00 k	3.63 k
0.45	0.39	45.0	40.8	4.50 k	4.08 k
0.50	0.43	50.0	45.4	5.00 k	4.54 k
0.60	0.51	60.0	54.5	6.00 k	5.45 k
0.70	0.60	70.0	63.6	7.00 k	6.36 k
0.80	0.70	80.0	72.7	8.00 k	7.27 k
0.90	0.79	90.0	81.7	9.00 k	8.17 k
1.00	0.88	100	90.8	9.99 k	9.08 k
1.50	1.40	150	133		
2.00	1.87	200	179		
2.50	2.35	250	224		
3.00	2.82	300	270		
3.50	3.30	350	315		
4.00	3.78	400	360		
4.50	4.25	450	406		
5.00	4.73	500	451		
6.00	5.68	600	542		
7.00	6.63	700	633		
8.00	7.59	800	724		
9.00	8.54	900	815		

18.3 Table 3

Limit Value	$R_{ISO} \text{ M}\Omega$	
	Min. Display Value	Min. Display Value
0.10	0.12	10.0
0.15	0.17	15.0
0.20	0.23	20.0
0.25	0.28	25.0
0.30	0.33	30.0
0.35	0.38	35.0
0.40	0.44	40.0
0.45	0.49	45.0
0.50	0.54	50.0
0.55	0.59	60.0
0.60	0.65	70.0
0.70	0.75	80.0
0.80	0.86	90.0
0.90	0.96	100
1.00	1.07	150
1.50	1.59	200
2.00	2.12	250
2.50	2.65	300
3.00	3.17	
3.50	3.70	
4.00	4.23	
4.50	4.75	
5.00	5.28	
6.00	6.33	
7.00	7.38	
8.00	8.44	
9.00	9.49	

18.4 Table 4

Limit Value	$R_{LO} \Omega$	
	Max. Display Value	Max. Display Value
0.10	0.07	10.0
0.15	0.12	15.0
0.20	0.17	20.0
0.25	0.22	25.0
0.30	0.26	30.0
0.35	0.31	35.0
0.40	0.36	40.0
0.45	0.41	45.0
0.50	0.46	50.0
0.60	0.55	60.0
0.70	0.65	70.0
0.80	0.75	80.0
0.90	0.84	90.0
1.00	0.94	99.9
1.50	1.42	
2.00	1.90	
2.50	2.38	
3.00	2.86	
3.50	3.34	
4.00	3.82	
4.50	4.30	
5.00	4.78	
6.00	5.75	
7.00	6.71	
8.00	7.67	
9.00	8.63	

18.5 Table 5

Limit Value	$Z_{ST} \text{ k}\Omega$	
	Min. Display Value	Min. Display Value
10	14	
15	19	
20	25	
25	30	
30	36	
35	42	
40	47	
45	53	
50	58	
56	65	
60	69	
70	80	
80	92	
90	103	
100	114	
150	169	
200	253	
250	315	
300	378	
350	440	
400	503	
450	565	
500	628	
600	753	
700	878	
800	>999	



18.6 Table 6

**Short-Circuit Current Minimum Display Values**

for the determination of nominal current for various fuses and breakers for systems with nominal voltage of  $U_N=230/240\text{ V}$

Nominal Current $I_N$ [A]	Low Resistance Fuses in accordance with the DIN VDE 0636 series of standards				with Circuit Breaker and Line Switch							
	Characteristic gL, gG, gM		Characteristic gL		Characteristic B/E (formerly L)		Characteristic C (formerly G, U)		Characteristic D		Characteristic K	
	Breaking Current $I_A$ 5 s		Breaking Current $I_A$ 0.4 s		Breaking Current $I_A$ $5 \times I_N (< 0.2\text{ s}/0.4\text{ s})$		Breaking Current $I_A$ $10 \times I_N (< 0.2\text{ s}/0.4\text{ s})$		Breaking Current $I_A$ $20 \times I_N (< 0.2\text{ s}/0.4\text{ s})$		Breaking Current $I_A$ $12 \times I_N (< 0.1\text{ s})$	
	Limit Value [A]	Min. Display [A]	Limit Value [A]	Min. Display [A]	Limit Value [A]	Min. Display [A]	Limit Value [A]	Min. Display [A]	Limit Value [A]	Min. Display [A]	Limit Value [A]	Min. Display [A]
2	9.2	10	16	17	10	11	20	21	40	42	24	25
3	14.1	15	24	25	15	16	30	32	60	64	36	38
4	19	20	32	34	20	21	40	42	80	85	48	51
6	27	28	47	50	30	32	60	64	120	128	72	76
8	37	39	65	69	40	42	80	85	160	172	96	102
10	47	50	82	87	50	53	100	106	200	216	120	128
13	56	59	98	104	65	69	130	139	260	297	156	167
16	65	69	107	114	80	85	160	172	320	369	192	207
20	85	90	145	155	100	106	200	216	400	467	240	273
25	110	117	180	194	125	134	250	285	500	578	300	345
32	150	161	265	303	160	172	320	369	640	750	384	447
35	173	186	295	339	175	188	350	405	700	825	420	492
40	190	205	310	357	200	216	400	467	800	953	480	553
50	260	297	460	529	250	285	500	578	1000	1.22 k	600	700
63	320	369	550	639	315	363	630	737	1260	1.58 k	756	896
80	440	517									960	1.16 k
100	580	675									1200	1.49 k
125	750	889									1440	1.84 k
160	930	1.12 k									1920	2.59 k

**Example**

Display value 90.4 A → next smallest value for circuit breaker characteristic B from table: 85 A → protective device nominal current ( $I_N$ ) max. 16 A

## 18.7 List of Abbreviations and their Meanings

### RCCBs (Residual Current Device/RCD)

$I_{\Delta}$	Tripping current
$I_{\Delta N}$	Nominal residual current
$I_{F\blacktriangleleft}$	Rising test current (residual current)
PRCD	Portable residual current device
$R_E$	Calculated earthing or earth electrode loop resistance
<b>S</b>	Selective residual current device
SRDC	Socket residual current device (permanently installed)
$t_A$	Time to trip / breaking time
$U_{I\Delta}$	Contact voltage at moment of tripping
$U_{I\Delta N}$	Contact voltage in relationship to nominal residual current $I_{\Delta N}$
$U_L$	Contact voltage limit value

### Overcurrent Protective Devices

$I_K$	Calculated short-circuit current (at nominal voltage)
$Z_l$	Line impedance
$Z_{Loop}$	Loop impedance

### Earthing

$R_B$	Operational earth resistance
$R_E$	Measured earthing resistance
$R_{ELoop}$	Earth electrode loop resistance

### Low-Value Resistance at Protective, Earthing and Bonding Conductors

$R_{LO+}$	Bonding conductor resistance (+ pole to PE)
$R_{LO-}$	Bonding conductor resistance (- pole to PE)

### Insulation

$R_{E(ISO)}$	Earth leakage resistance (DIN 51953)
$R_{ISO}$	Insulation resistance
$R_{ST}$	Standing surface insulation resistance
$Z_{ST}$	Standing surface insulation impedance

### Current

$I_A$	Breaking current
$I_L$	Leakage current (measured with clip-on current transformer)
$I_M$	Measuring current
$I_N$	Nominal current
$I_P$	Test current

### Voltage

$f$	Line voltage frequency
$f_N$	Nominal voltage rated frequency
$U_{Batt}$	Operating voltage
$U_E$	Earth electrode voltage
$U_{L-L}$	Voltage between two phase conductors
$U_{L-N}$	Voltage between L and N
$U_{L-PE}$	Voltage between L and PE
$U$	Voltage
$U_N$	Nominal line voltage
$U_{3\sim}$	Highest measured voltage during determination of phase sequence
$U_{Probe}/U_{S-PE}$	Voltage between probe and PE (probe voltage)
$U_Y$	Conductor voltage to earth

### Z541A Temperature and Humidity Measuring Adapter

$F_{Rel}$	Relative humidity
Temp./9	Temperature

## 19 Repair and Replacement Parts Service Calibration Center \* and Rental Instrument Service

If required please contact:

GMC-I Service GmbH  
**Service-Center**  
Thomas-Mann-Strasse 20  
90471 Nürnberg • Germany  
Phone +49 911 817718-0  
Fax +49 911 817718-253  
E-mail [service@gossenmetrawatt.com](mailto:service@gossenmetrawatt.com)

This address is only valid in Germany.

Please contact our representatives or subsidiaries for service in other countries.

### \* **DKD** Calibration Laboratory for Electrical Quantities DKD–K–19701 accredited per DIN EN ISO/IEC 17025:2005

Accredited measured quantities: direct voltage, direct current values, DC resistance, alternating voltage, alternating current values, AC active power, AC apparent power, DC power, capacitance, frequency and temperature

#### Competent Partner

GMC-I Messtechnik GmbH is certified in accordance with DIN EN ISO 9001:2000.

Our DKD calibration laboratory is accredited by the Deutscher Kalibrierdienst (*German Calibration Service*) in accordance with DIN EN ISO/IEC 17025:2005 under registration number DKD–K–19701.

We offer a complete range of expertise in the field of metrology: from **test reports** and **proprietary calibration certificates** right on up to **DKD calibration certificates**.

Our spectrum of offerings is rounded out with free **test equipment management**.

An on-site **DKD calibration station** is an integral part of our service department. If errors are discovered during calibration, our specialized personnel are capable of completing repairs using original replacement parts. As a full service calibration laboratory, we can calibrate instruments from other manufacturers as well.

## 20 Recalibration Service

In our Service-Center we **calibrate** and **recalibrate** (e.g. after one year as part of your test equipment monitoring system, prior to use for ...) all instruments of GMC-I Messtechnik GmbH and other manufacturers and offer you free test equipment management. Address see under chapter 19.

## 21 Product Support

If required please contact:

GMC-I Messtechnik GmbH  
**Product Support Hotline**  
Phone +49 911 8602-0  
Fax +49 911 8602-709  
E-mail [support@gossenmetrawatt.com](mailto:support@gossenmetrawatt.com)

---

Edited in Germany • Subject to change without notice • A pdf version is available on the internet

 **GOSSEN METRAWATT**  
GMC-I Messtechnik GmbH  
Südwestpark 15  
90449 Nürnberg • Germany

Phone +49 911 8602-111  
Fax +49 911 8602-777  
E-Mail [info@gossenmetrawatt.com](mailto:info@gossenmetrawatt.com)  
[www.gossenmetrawatt.com](http://www.gossenmetrawatt.com)