

# HOBO<sup>®</sup> Weather Station User's Guide



### Contact Information

For support, please contact the company that you bought the product from: Onset Computer Corporation or an Onset Authorized Dealer.

Onset Computer Corporation  
470 MacArthur Blvd.  
Bourne, MA 02532

Mailing Address:  
P.O. Box 3450  
Pocasset, MA 02559-3450  
Phone: 1-800-LOGGERS (1-800-564-4377) or 508-759-9500  
Fax: 508-759-9100

Hours of Operation: 8AM and 5PM Eastern Time  
E-mail: [loggerhelp@onsetcomp.com](mailto:loggerhelp@onsetcomp.com)  
Main Onset Web site: [www.onsetcomp.com](http://www.onsetcomp.com)  
FTP site: [ftp.onsetcomp.com](ftp://ftp.onsetcomp.com)

If you purchased the products through an Onset Authorized Dealer, you can also refer to [www.hobohelp.com](http://www.hobohelp.com) for support information.

### Safety Information – Read first



**WARNING:** Severe shock hazard. Before installing weather station tripod or mounting poles, ensure that there are no electrical power lines overhead. Do not install the system during any atmospheric electrical activity. Do not assemble or transport tripods, mounting poles, or other structures unless there is sufficient clearance from potential electrical sources or other obstructions.



**WARNING:** Do not climb on or around the weather station tripod. The weather station and any of its associated hardware, towers, poles, etc. are not designed to support the weight of a person. Injury may result.



**WARNING:** If using stakes to stabilize the tower, ensure that there are no underground wires or pipes under the weather station.



**WARNING:** Fire, Explosion, and Severe Burn Hazard. The logger may contain a lithium battery. The battery may explode if the logger is exposed to extreme heat or conditions that could damage or destroy the battery case. Do not attempt to recharge or heat the logger or battery above +185°F (+85°C). Do not dispose of the logger or battery in fire. Do not expose the contents of the battery to water. Dispose of the battery according to local regulations for lithium batteries.



**WARNING:** Do not use weather station as part of a critical control system. This system is not intended to be a fail-safe mechanism for anticipating life-threatening conditions, such as flash floods.

© 2009 Onset Computer Corporation, all rights reserved.  
Printed in USA.

Onset and HOBO are registered trademarks of the Onset Computer Corporation. Other products and brand names may be trademarks or registered trademarks of their respective owners.

---

# Table of Contents

<b>Section 1:</b>	<b>Introduction.....</b>	<b>5</b>
	How to Use this Manual .....	5
	Specifications .....	6
	Logger components .....	7
	Status Lights .....	8
<b>Section 2:</b>	<b>Setup and Test.....</b>	<b>9</b>
	Items Required.....	9
	Steps .....	10
	Communicating with the Logger.....	11
	Launching the Logger .....	11
	Reading out Data .....	12
	Batteries .....	13
	Estimating Battery Life .....	14
	Additional guidelines:.....	14
	Using a 9-Volt Battery .....	15
	Using a 9-Volt Battery Eliminator .....	15
	Adding and Removing Sensors.....	16
<b>Section 3:</b>	<b>Field Setup .....</b>	<b>17</b>
	Guidelines for Typical Field Setup .....	18
	Site Selection .....	18
	Mounting .....	19
	Installing Sensors.....	19
	Field Preparation Checklist .....	20
	Tasks for Setting up the Tri-pod.....	23
	Task 1: Assemble Tripod .....	24
	Task 2: Install Grounding Kit.....	31
	Task 3: Temporarily Install Upper Mast (Optional) .....	32
	Task 4: Mount Cross Arm (Optional) .....	33
	Task 5: Mount Upper Mast to Lower Mast.....	34
	Task 6: Mount Logger to Upper Mast .....	35
	Task 7: Install Guy Wire Kit (Optional).....	36
	Task 8: Position and Level Sensors .....	38
	Task 9: Final Setup .....	38

---

<b>Section 4:</b>	<b>Maintenance .....</b>	<b>41</b>
	General Maintenance .....	41
	Performing a visual inspection .....	41
	Batteries .....	42
	Checking Battery Status .....	42
	Changing Batteries .....	42
	Cleaning the Weather Station .....	43
	Verifying Sensor Accuracy .....	43
<b>Section 5:</b>	<b>Reference .....</b>	<b>45</b>
	Memory .....	45
	Time Accuracy.....	47
	Resetting the Clock .....	48
<b>Section 6:</b>	<b>Troubleshooting .....</b>	<b>49</b>

# Section 1: Introduction

The HOBO® Weather Station is a data logger designed for multi-channel climate monitoring. The Weather Station represents the next generation of data logging because it uses a network of smart sensors for taking measurements. Key features of the smart sensors include:

- **Automatic detection.** No extensive programming, wiring, or calibrating is required to set up sensors.
- **Easy expansion.** Because the logger is not pre-configured, up to 15 sensor parameters of any type or combination can be added simply by plugging them in before logging begins.
- **Digital network.** The connections between the smart sensors and the logger are digital, ensuring accurate, reliable data collection and storage.



## How to Use this Manual

This manual walks you through the steps of setting up, operating, and maintaining the HOBO Weather Station. Use this manual to learn how to:

- Setup the logger and perform an initial test
- Deploy the Weather Station in the field
- Troubleshoot problems
- Maintain the Weather Station

It is important that you setup and test your logger using the steps in Section 2 before continuing with deploying the Weather Station on site.

For your convenience, this manual includes three section dividers to organize sensor manuals and hardware packing lists. It is recommended that you add all sensor manuals and hardware packing lists to this binder.

## Specifications

<b>HOBO Weather Station</b>	
<b>Operating Range</b>	-20° to 50°C (-4° to 122°F) with alkaline batteries, -40° to 70°C (-40° to 158°F) with lithium batteries
<b>Sensor Inputs</b>	10, expandable to 15 with optional adapters
<b>Data Channels</b>	Maximum of 15 (some sensors use more than one data channel; see sensor manual for details)
<b>Communication</b>	3.5 mm serial port or weatherproof external connector
<b>Dimensions</b>	23 cm H x 10 cm D x 18 cm W (9 x 4 x 7 inches)
<b>Weight</b>	0.9 kg (2 lbs)
<b>Memory</b>	512K nonvolatile flash data storage
<b>Memory Modes</b>	Stop when full, wrap around when full
<b>Operational Indicators</b>	Seven status lights provide logging and sensor network status
<b>Logging Interval</b>	1 second to 18 hours, user-specified interval
<b>Battery Life</b>	1 year typical use (up to 10 sensors with 10 minutes or longer logging interval)
<b>Battery Type</b>	Four standard AA alkaline batteries included (for operating conditions - 20° to 50°C [-4° to 122°F]); optional AA lithium batteries available for operating conditions of -40° to 70°C (-40° to 158°F)
<b>Time Accuracy</b>	0 to 2 seconds for the first data point and $\pm 5$ seconds per week at 25°C (77°F)
<b>Data Type</b>	Supports measurement averaging based on availability of supporting data from sensor
<b>Logger Start Modes</b>	Immediate, push-button, or delayed start options
<b>Data Communication</b>	Current reading while logging, offload while logging, or offload when stopped
<b>Environmental Rating</b>	Weatherproof
<b>Mounting</b>	Mast (3.8 cm [1.5 inches] maximum diameter) or wall mount
<b>Enclosure Access</b>	Hinged door secured by four screws
<b>Sensor Network Cable Length</b>	100 m (328 ft) maximum
<b>Part Number</b>	H21-001

## Logger components

The following diagram explains the key parts of the Weather Station.

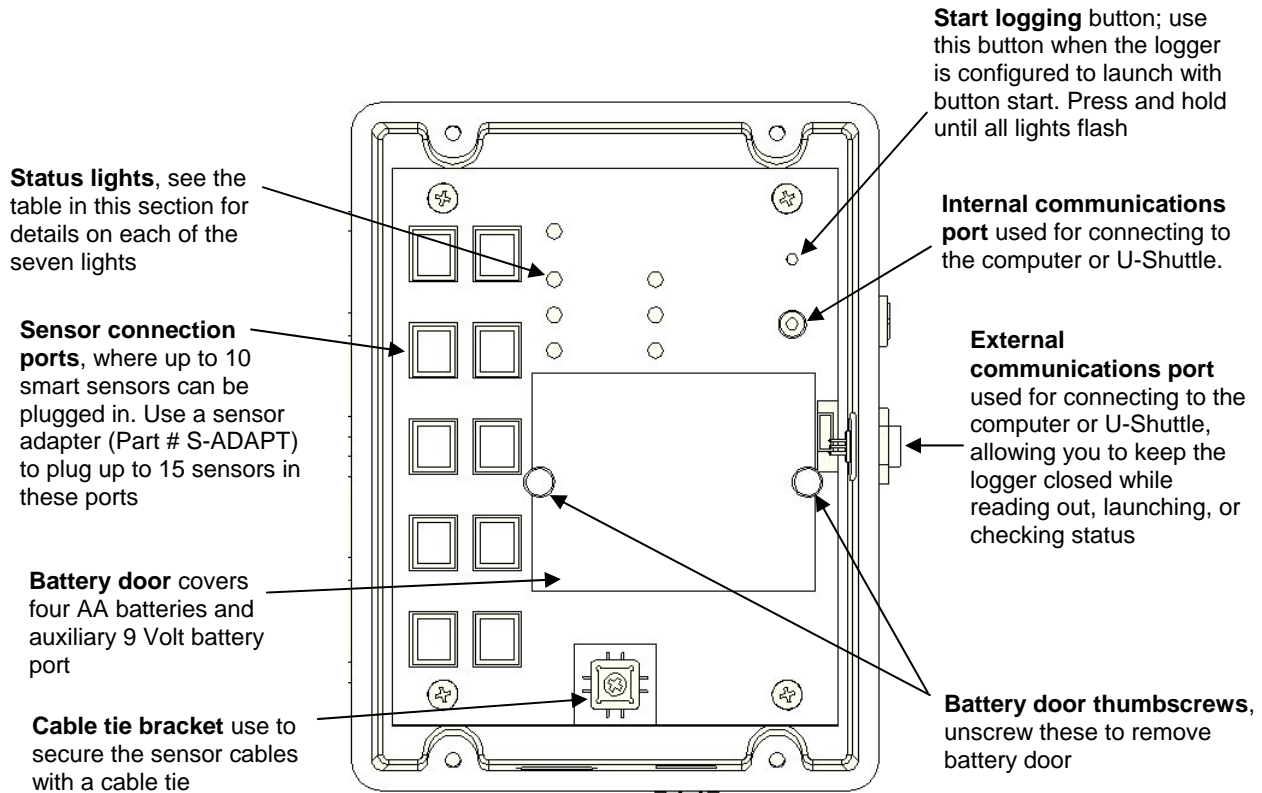

Figure 1: All logger components

## Status Lights

There are seven lights on the Weather Station that indicate logger activity and status. The following table explains the function of these lights.

This light:	Blinks when:	Notes
Sensor Activity	There is activity on the sensor network.	Network activity is defined as communication from the logger to the sensor or vice versa.
Delay Start	The logger has been configured to launch with a delayed start; will continue blinking until the defined start date/time.	The logger will not record measurements while this light is blinking. Sensors can be added at this time.
Button Start	The logger has been configured to start with a button start; will continue blinking until you press and hold the button on the logger for a couple of seconds.	The logger will not record measurements while this light is blinking. Sensors can be added at this time.
OK	Every two seconds while the logger is recording data from sensors.	Sensors <i>cannot</i> be added at this time.
Bat Low	The battery power is less than 25% capacity.	The logger will continue to run. However, you should read out the logger and then replace the batteries soon.
Mem Low	Less than 25% of memory is available for saving data.	The logger will continue to run until all memory is used. This light will only blink if the launch parameter "Wrap Around When Full" is not selected (see the <i>Launching</i> section on page 11 for details on the Wrap Around When Full setting).
Error	There is or has been a sensor communication failure.	<p>If this light is blinking in conjunction with the OK light, there was a communication failure. The system has recovered, but you may have an intermittent problem.</p> <p>If this is the only blinking light, then at least one sensor is currently not communicating. Immediate investigation is recommended.</p> <p>In general, it is recommended that you read out any data when this light is blinking, investigate the problem, and re-launch the logger.</p>



## Section 2: Setup and Test

Onset recommends that you setup and test the logger before deploying the Weather Station in the field.

### **Items Required**

To setup the logger, you will need the following materials:

- Flat head screwdriver
- Four AA alkaline batteries (included with the logger) or four AA lithium batteries
- One or more smart sensors
- PC interface cable (Onset part number CABLE-PC-3.5)
- Computer with logger software installed

## Steps

Complete the following steps to setup your Weather Station.

1. Use a flat head screwdriver to loosen the four screws on the front cover of the logger. Open the logger door.
2. Unscrew the two thumbscrews on the battery door cover and remove the battery door. Insert four AA alkaline or lithium batteries, observing polarity. Once the batteries are installed correctly, the status lights will blink for a second. See Batteries on page 13 for more details.

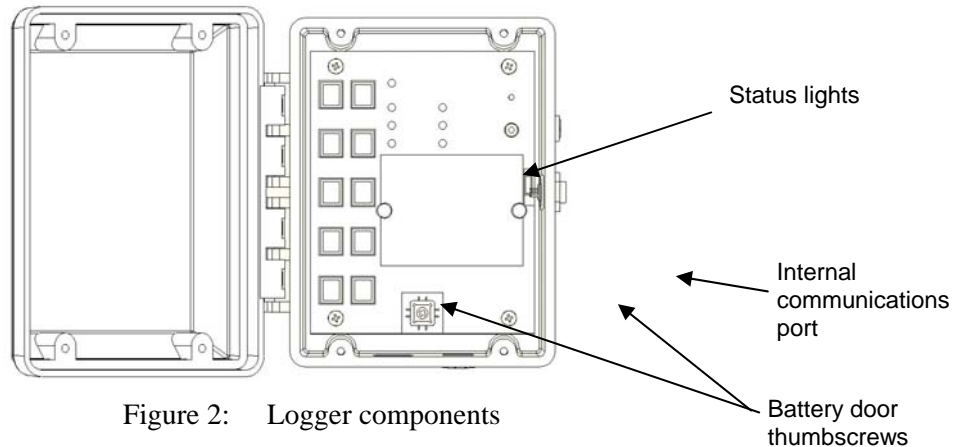

Figure 2: Logger components

3. Replace the battery door cover and thumbscrews.
4. Insert one or more sensors into the sensor ports. Refer to [www.onsetcomp.com](http://www.onsetcomp.com) for a current list of available sensors. Onset recommends that you test all sensors you plan to deploy with the logger.  
Refer to the manuals provided with the sensors for sensor specifications, mounting information, and recommended maintenance.  
See Adding and Removing Sensors on page 16 for details.
5. Plug the PC interface cable into the internal communications port on the logger. See Communicating with the Logger on page 11 for details.
6. Using the logger software, click the Launch icon. If the logger is not found, make sure the correct COM port is selected. Refer to the *HOBOWare User's Manual* for details on changing the COM port. See Launching the Logger on page 11 for details.
7. Make sure all the sensors connected to the logger are visible in the **Launch** screen.
8. Choose a **Logging Interval** of a few seconds so that your test will yield enough data to analyze. Select the **Start Logging Now** option, and click the **Start** button to launch the logger. The "logging ok" light on the logger should blink every two seconds during logging.
9. After a couple of minutes, click the Readout icon in the logger software to offload data from the logger. You can choose to either stop the logger before reading it out, or let it continue logging while reading out. See Reading out Data on page 12 for details.
10. Check the data and make sure it appears normal for all sensors.

Congratulations! You have now launched and offloaded the Weather Station. Proceed to Section 3: Field Setup on page 17 for details on deploying the logger.

## Communicating with the Logger

The logger has both an internal and external communication port for connection with a computer or U-Shuttle. See the Shuttle manual for information on using the logger with a U-Shuttle.

The internal port is located inside the logger enclosure (labeled “comm. port”).

The external port is located outside the logger enclosure (see Figure 2) and requires the weatherproof external communications cable (Part # CABLE-HWS2). Use this port to quickly connect to the logger without having to open the logger door.

## Launching the Logger

There are several parameters you can enter when launching the Weather Station with the logger software. To launch the logger, connect to it as described in *Communicating with the logger* on page 11 and then enter the following launch parameters. **Note:** If you are launching the logger with a U-Shuttle it will be launched with the parameters you last entered in the logger software on the computer.

Launch parameter	Description
Description	Enter a description of the launch.
Battery type	Make sure the appropriate battery type is selected, otherwise the battery gauge will not be accurate when checking the logger status.
Logging interval	Set how often the logger will record data (for example every 30 minutes, hour, etc). The minimum logging interval is 1 second and the maximum is 18 hours. <b>Keep in mind that the faster the logging interval, the more quickly the batteries will be depleted.</b> See the <i>Estimating Battery Life</i> section on page 14 for more details.
Sampling interval	<p>For use with sensors that support software-selectable measurement averaging. The sampling interval sets how often sensors will take measurements between logging intervals. Check the sensor's data sheet or manual to determine if your sensor supports measurement averaging. When a sampling interval is used during launch, all the sampled measurements for the sensor are averaged together and the average is then recorded as one data point at each logging interval. The individual data points that comprise the average are not saved; only the final, averaged data point is saved.</p> <p>Set the sampling interval to one of the predefined settings from 1 second to 4 minutes. The sampling interval must be less than or equal to the logging interval. <b>Sampling rates shorter than 1 minute will reduce the logger's battery life.</b></p> <p><b>Important:</b> If you do not have any sensors that support measurement averaging, set the sampling interval to “Off” as there will be no benefit and it will reduce battery consumption.</p>
When to start logging	<p>Choose one of the following start modes for the logger:</p> <ul style="list-style-type: none"> <li>• <b>Start logging now.</b> The logger will start recording measurements as soon as you are finished configuring the launch.</li> <li>• <b>Delayed start.</b> The launch is postponed until the exact date and time you specify. You can add sensors to the logger any time before the specified start time.</li> <li>• <b>Button start.</b> The launch will not start until you press a button on</li> </ul>

Launch parameter	Description
	<p>the logger. This allows you to configure the launch settings in advance, but start the actual launch when you want without choosing a specific date and time. You can add sensors any time before pressing the button on the logger.</p> <ul style="list-style-type: none"><li>• <b>Save settings for a later launch.</b> Select this option when you want to save the current launch settings for a future launch, but not start the launch now (for example, prior to heading into the field). This is useful if you plan on launching the logger with a shuttle, which doesn't allow you to change launch settings.</li></ul>
Wrap around when full	When this box is checked, new data will overwrite the oldest data in the logger sequentially one sample at a time when the memory is full. The logger will continue logging indefinitely until either the logger is read out and stopped or the battery fails. If this box is not checked, the logger will stop logging when the memory is full and preserve acquired data. For more information on memory, see the <i>Logger memory</i> section on page 45.
Edit sensor locations	Give each sensor a name of up to 30 characters to help identify individual sensors.
Deployment notes	Add up to 2000 characters of notes about the launch.

## Reading out Data

You can read out data (offload) the logger with logger software. Connect to the logger as described in *Communicating with the logger* on page 11 and then read it out. If the logger is logging, you can choose to either stop the logger before reading out or let it continue logging while reading out.

Readout speed depends on the method used to connect to the logger and the device being used. Typically, a readout via PC interface cable with the computer will take about six minutes for full memory (512K of data).

## Batteries

The Weather Station requires four 1.5 V AA batteries. The logger is shipped with four alkaline batteries, but it is also compatible with lithium batteries. For most applications, alkaline batteries are the preferred solution because:

- They are relatively inexpensive
- The battery gauge in the logger software will provide an accurate battery status
- They have slightly more usable capacity than 1.5 Volt lithium batteries in temperate environments

In cold applications (below 0°C [32°F]) and hot applications (above 40°C [104°F]), lithium batteries will generally outperform alkaline batteries. Alkaline batteries will still work in temperatures ranging from 40° to 50°C (104° to 122°F) and from -20° to 0°C (-4° to 32°F), however, they may not be the best choice. At temperatures lower than -20°C (-4° F) and higher than 50°C (122°F), alkaline batteries are unsuitable; use lithium instead. If the temperature is variable across the extremes, use lithium batteries. Use the following figure to help you choose the battery type based on the expected temperature range in your deployment.

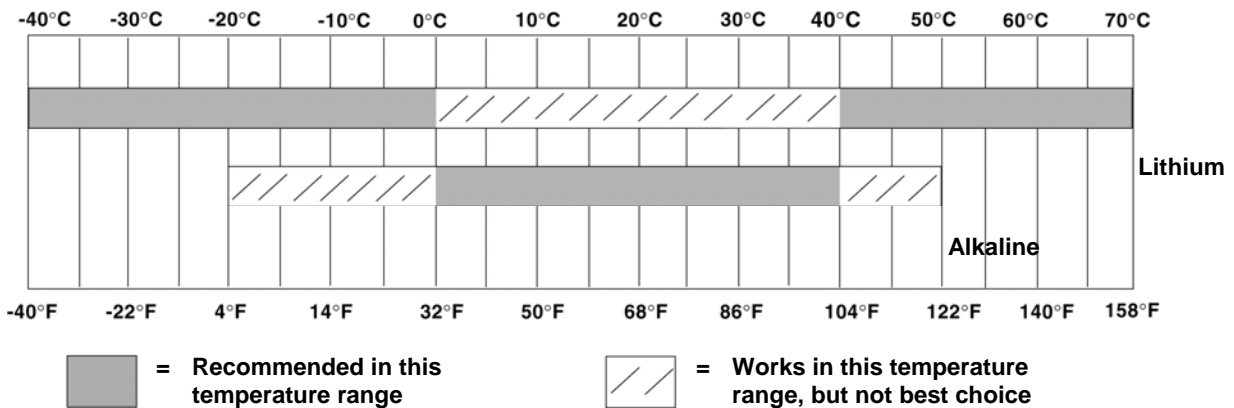

Figure 3: Recommended battery type based on temperature

### Note:

- The logger is not designed to run with rechargeable or Carbon Zinc “Heavy Duty” batteries.
- The use of types other than 1.5 Volt alkaline or lithium batteries may result in poor battery performance and erroneous battery state indication.



**WARNING: Fire, Explosion, and Severe Burn Hazard.** Do not mix battery types, either by chemistry or age; batteries may rupture or explode. When replacing the batteries, read and follow their disposal instructions; dispose of lithium batteries according to local regulations. Do not dispose of batteries in fire. Never attempt to recharge a lithium or alkaline battery. Do not heat the batteries above 185°F (85°C). Do not mutilate or rupture the battery housing. Lithium batteries may explode if the logger is exposed to extreme heat or conditions that could damage or destroy the battery case. Do not expose the contents of the battery to water.

## Estimating Battery Life

Battery life will vary with:

- Logging and sampling intervals (most important factor)
- The number of sensors connected
- Battery type
- Operating environment

Use the following table to help you estimate how long the batteries will last (the run time) based on the logging interval selected and the number of sensors connected. **Note:** The run times in this table assume that the recommended battery type for the temperature range is being used.

Logging Interval	Sampling Interval	1 to 5 sensors	5 to 10 sensors	10 to 15 sensors
1 second	Off	30 to 50 days	20 to 40 days	15 to 30 days
1 minute	Off	12 months	9 to 12 months	7 to 10 months
10 minutes	1 minute	12 months	12 months	9 to 12 months
15+ minutes	1 minute	12 months	12 months	9 to 12 months

### Additional guidelines:

- Turn off the sampling interval unless you have sensors that support measurement averaging. At the time of publication, only the 12-bit Temperature, Soil Moisture, Barometric Pressure, Photosynthetically Active Radiation, and Solar Radiation smart sensors and the 4-20 mA and 0-5 Volt input adapters supported measurement averaging. Check the sensor manual to see if your sensor supports measurement averaging.
- Make sure the “Use Before” date on the battery housing is at least two years from the current date.
- Alkaline batteries will lose up to 10% of capacity a year sitting on a hot shelf and can lose up to 50% or more if “cooked” repeatedly (for example, stored on a car dashboard). Keeping batteries in the refrigerator can reduce self-discharge to 1 to 2% per year, however, be sure to avoid condensation forming on the batteries.
- Use new batteries if you expect the deployment to require a substantial portion of battery life based on the table above.
- Batteries are relatively inexpensive; don’t take a chance with suspect batteries.

## Using a 9-Volt Battery

The Weather Station has an additional 9-volt battery connector adjacent to the four AA battery compartment. Insert a 9-volt battery to temporarily maintain the power to the logger, which allows you to replace aging AA batteries with fresh ones without interrupting logging.

### Steps

1. Unscrew the two thumbscrews on the battery door cover and remove the battery door.
2. Plug a 9 Volt battery into the battery connector to the right of the four AA batteries (observe polarity). Press firmly to make sure the connection is solid.
3. Remove the old AA batteries.
4. Insert the new AA batteries.
5. Remove the 9 Volt battery.
6. Replace the battery door cover and thumbscrews.
7. Verify that the logger is operating normally by checking that the “Logging OK” status light is still blinking every two seconds.

While it is possible to run the logger with only a 9 Volt battery, it is not recommended for extended deployment for the following reasons:

- A 9 Volt battery will only last about one to two months (typical use).
- The logger and its software do not provide an accurate battery level indication for a 9 Volt battery.
- The logger battery door cannot be used with a 9 Volt battery in place, it is possible that the batteries will shake loose.
- The 9 Volt battery cannot be used as a “backup” battery. The opposite actually occurs; the 9 Volt battery will be used first, and then the AA batteries will be used.

**Note:** When changing batteries on the fly, the 9 Volt battery must have at least 7.5 volts remaining. If the 9 Volt battery has less than 7.5 volts, the battery gauge will not reset when new AA batteries are installed. Use a fresh 9 Volt battery if you find that the battery gauge does not reset.

## Using a 9-Volt Battery Eliminator

In some applications where AC power is available, it may be convenient to use a 9 Volt batter eliminator to power the logger. 9 Volt DC supplies are commonly available from electronics supply stores (Radio Shack catalog number 273-1552B). Minimum DC current should be 9 mA. If four AA batteries are also used with the 9V battery eliminator, they will serve as back-up batteries. **Note:** The batteries will NOT be charged and rechargeable batteries should not be used with the logger.

## Adding and Removing Sensors

Smart sensors plug into the logger and collect data about various weather parameters. Before you bring the logger and sensors to the field, it is important that you gather and test all the sensors. Specifically, you should:

- Plug in all the sensors you plan to use,
- Make sure they are communicating, and
- Make sure the readings are valid.

To add a sensor, simply plug it into a sensor port on the logger. Follow these guidelines when adding sensors:

- **Never add or remove sensors while the logger is recording data.** Sensors should only be added while the logger is stopped, when configuring the launch parameters with logger software, or after configuration but before the start of logging in Delayed Start or Button Start modes (for more information on these modes, see the *Launching* section on page 11).
- **Any sensors added while the logger is recording data will be ignored.** Logging will continue normally for other sensors. If a sensor is removed while logging, the Sensor Error status light will blink when the next logging interval is reached. The data for that sensor will then display as missing or erroneous in readouts.
- **You cannot replace one sensor with a new sensor of the same type while logging.** If you would like to replace a sensor with another sensor of the same type (for example, swap a temperature sensor with a new temperature sensor), it is necessary to read out the current data from the logger and re-launch with the new sensor.
- **A maximum of 15 data channels can be used with one logger.** Most sensors use one data channel, which means the sensor is measuring one property only (for example a temperature sensor uses one data channel that records information for temperature). However, there are some sensors that measure more than one property, such as the combination temperature/RH sensor, which uses two data channels.
- **To expand the number of sensors plugged in and data channels used, use 1-to-2 sensor adapters** (Part # S-ADAPT), which allow you to plug two sensors into one port. Note that the 1-to-2 adapter is similar to a standard telephone splitter, but it has 6 conductors. Most telephone splitters have only 4 conductors. A 4-conductor splitter may work, but it is not recommended because the shield in the cable will not be properly grounded.
- **The logger can work with a maximum of 100 meters (328 feet) of smart sensor network cable,** which is the digital communications portion of the sensor cables. If you are using multiple sensors, be sure to check the length of each smart sensor network cable reported in the Sensor Manuals. Add them together and make sure they *do not exceed 100 meters (328 feet)*.



## Section 3: Field Setup

After you've configured the logger and gathered the necessary materials for the field, you are ready to assemble the tripod with the logger and sensors. This document includes:

- ✓ Guidelines for typical field setup
- ✓ Field preparation checklist
- ✓ Tasks for setting up the Tri-pod

## Guidelines for Typical Field Setup

### Site Selection

Use the following guidelines to help you choose an appropriate site for setting up the Station and protecting against field hazards.

- When possible, select a location away from trees and buildings, particularly if you will be using the rain gauge or wind speed sensors. Place the rain bucket at a distance away from obstructions that is equal to at least three times the height of the nearest tree, building, or other obstruction, and the wind speed sensor at a distance away from obstructions that is equal to at least five times the height of the obstruction.



**WARNING: Severe shock hazard.** Do not set up the HOBO Station near power lines. Contact between the HOBO Station and power lines may result in a fatal shock, electrocution, or death.

- Avoid placing the logger in extremely hot locations (such as on a dashboard or the roof of a greenhouse) and chronically wet locations (such as in a well or any place that is wet most or all of the time). Also avoid rising water and flood zones.
- Conduit is recommended when placing a sensor in or near the ground to protect against animals, lawn mowers, tractors, exposure to chemicals, etc.
- Beware of rodents, birds, cattle, and other animals that can bite, peck, or trample the HOBO Station.
- Avoid placing the sensors near falling rocks, dead trees, or other objects that could fall on the HOBO Station.
- A Grounding Kit (Part # M-GKA) is required if using the wind speed or wind speed and direction sensor with the logger. A Grounding Kit is recommended if the logger will be placed in an exposed location on a tripod or tower to reduce the chance of damage from atmospheric electrical activity.
- If possible, avoid sites immediately adjacent to radio/television/microwave towers and equipment. In rare situations, strong electromagnetic interference may result in sensor network errors.
- Take note of the mounting considerations in the sensor manuals for additional guidelines relative to the particular sensors you are using.
- For areas with winds greater than 50 mph, or if the rain gauge is attached to the top of the mast, use the Guy Wire Kit (Part # M-GWA) and 1/2 inch Stake Kit (Part # M-SKA) to reduce wind-induced vibration.
- **2 meter Tripod Tower Assembly (Part # M-TPB):** You must set up the tower on level ground; there should be no ground slope. The legs on the 2 meter tower are non-adjustable. If the site you are using is not level, then you will need to either level it or use shims to level the tripod. Be prepared to dig if necessary. Suggested Mounting: Use 1/4 inch Stake Kit (Part #M-SKB).
- **3 meter Tripod Tower Assembly (Part # M-TPA):** The maximum ground slope is 13 degrees. The legs on the 3 meter tower allow for limited adjustment on uneven ground. Be prepared to dig if necessary if the slope is significant. Suggested Mounting: Use 1/2 inch Stake Kit (Part # M-SKA).
- Onset recommends that two people set up most tripod systems. Some assemblies are heavy and are easier to handle with two people.
- Be sure to stabilize, level, and secure the tripod on firm ground. It may be necessary to adapt the installation to the existing site conditions as necessary (for example, if mounting the tripod on ice or rock, you may need to use a masonry clamp to secure it).
- If operating in a wet environment, place several desiccant packs in the logger and plug the vent hole in the bottom of the logger enclosure to minimize moisture.

## Mounting

It is possible to mount the logger and sensors on either a 1.5 meter or 3 meter mast (Part # M-MPB and M-MPA respectively). The shorter mast is especially useful for smaller system configurations where you are trying to minimize the size and visibility of the system.

There are many ways to install the mast depending on the site. Common mounting methods include pounding the post into the ground, setting it into concrete, and bolting it to existing structures.

- If you will be mounting PAR, wind speed, or rain gauge sensors, be sure that you install the mast vertically (using Mast Level, Part # M-MLA).
- Use the Guy Wire Kit (Onset Part # M-GWA) to stabilize a tall mast. Use 1/2 inch stakes (Part # M-SKA) to secure the guy wires.
- Mount the logger vertically and high enough that ground splash will not enter the vent on the underside of the enclosure.
- If using U-bolts, make sure they are for 1-5/8 inch pipe because that is the hole spacing on the logger mounting bracket.
- If mounting the logger to a post or wall, note that it is 2.06 inches between the center of the holes in the mounting brackets. It is recommended that you use 5/16 inch diameter bolts to mount the logger.

## Installing Sensors

- If running cables along the ground, we recommend running them through conduit to protect them from animals (some animals like to chew on the cables), lawn mowers, and being tripped on.
- For information on protecting the sensors properly, refer to the sensor manuals.
- Leave enough slack in the cables so that they can be routed into the logger.
- If you are deploying multiples of the same sensor type, be sure to note the serial number on the cable associated with each measurement location so you can interpret the data later.

## Field Preparation Checklist

Use the following checklist to make sure you have all the necessary materials for setting up a HOBO Station.

✓	Task																																												
	Check that you received all the parts for the HOBO Station system as ordered.																																												
	Configure the logger. Install batteries and set up the logger for launch.																																												
	If you opened any parts: Double-check the packing lists to make sure no pieces are missing.																																												
	Attach the mounting feet to the logger. See the logger's manual.																																												
	If you are using the Solar Radiation Shield: Set up the Temperature and Temperature/RH sensors. There are several small pieces required to connect these sensors to the shield that could easily get lost in the field. It is strongly recommended you install these sensors in the solar radiation shield before going to the field. See the sensor manual for details.																																												
	If you are using the barometric pressure sensor, attach it to the logger now. See the sensor manual for details.																																												
	Repack the logger and sensors for transit. It is strongly recommended that you use the original packaging when possible because it is custom-designed to protect the weather station and its components.																																												
	<p>Gather the tools required for setup. Use the following checklists to make sure you have the necessary tools to set up the logger in the field. "Optional" Items depend on your site needs.</p> <table border="1" style="width: 100%; border-collapse: collapse;"> <thead> <tr> <th colspan="2" style="text-align: left;"><b>Logger</b></th> <th colspan="2" style="text-align: left;"><b>Rain Gauge Sensor</b></th> </tr> <tr> <th style="text-align: left;">Item</th> <th style="text-align: center;">✓</th> <th style="text-align: left;">Item</th> <th style="text-align: center;">✓</th> </tr> </thead> <tbody> <tr> <td>1/2 inch wrench</td> <td></td> <td>Mast level (Part # M-MLA) (optional; for mounting on separate mast)</td> <td></td> </tr> <tr> <td>Flathead screwdriver</td> <td></td> <td>Sledgehammer or post driver (optional; for mounting on separate mast)</td> <td></td> </tr> <tr> <td>Desiccant (optional)</td> <td></td> <td>Eye protection—safety glasses (if using sledgehammer/post driver)</td> <td></td> </tr> <tr> <td></td> <td></td> <td>Slotted screwdriver</td> <td></td> </tr> <tr> <td></td> <td></td> <td>Conduit (optional)</td> <td></td> </tr> </tbody> </table> <table border="1" style="width: 100%; border-collapse: collapse;"> <thead> <tr> <th colspan="2" style="text-align: left;"><b>Light Sensor</b></th> <th colspan="2" style="text-align: left;"><b>Wind Speed/Direction Sensor</b></th> </tr> <tr> <th style="text-align: left;">Item</th> <th style="text-align: center;">✓</th> <th style="text-align: left;">Item</th> <th style="text-align: center;">✓</th> </tr> </thead> <tbody> <tr> <td>Ladder (if deploying sensor above eye level)</td> <td></td> <td>7/16 inch wrench</td> <td></td> </tr> <tr> <td>Light sensor level (Part #M-LLA)</td> <td></td> <td>Crescent wrench (or second 7/16 inch wrench)</td> <td></td> </tr> </tbody> </table>	<b>Logger</b>		<b>Rain Gauge Sensor</b>		Item	✓	Item	✓	1/2 inch wrench		Mast level (Part # M-MLA) (optional; for mounting on separate mast)		Flathead screwdriver		Sledgehammer or post driver (optional; for mounting on separate mast)		Desiccant (optional)		Eye protection—safety glasses (if using sledgehammer/post driver)				Slotted screwdriver				Conduit (optional)		<b>Light Sensor</b>		<b>Wind Speed/Direction Sensor</b>		Item	✓	Item	✓	Ladder (if deploying sensor above eye level)		7/16 inch wrench		Light sensor level (Part #M-LLA)		Crescent wrench (or second 7/16 inch wrench)	
<b>Logger</b>		<b>Rain Gauge Sensor</b>																																											
Item	✓	Item	✓																																										
1/2 inch wrench		Mast level (Part # M-MLA) (optional; for mounting on separate mast)																																											
Flathead screwdriver		Sledgehammer or post driver (optional; for mounting on separate mast)																																											
Desiccant (optional)		Eye protection—safety glasses (if using sledgehammer/post driver)																																											
		Slotted screwdriver																																											
		Conduit (optional)																																											
<b>Light Sensor</b>		<b>Wind Speed/Direction Sensor</b>																																											
Item	✓	Item	✓																																										
Ladder (if deploying sensor above eye level)		7/16 inch wrench																																											
Light sensor level (Part #M-LLA)		Crescent wrench (or second 7/16 inch wrench)																																											

✓	Task																																																															
	Phillips head screwdriver #1			1.06 inch/2.00 inch hose clamps (if mast mounting without cross arm)																																																												
	Compass			Phillips-head screwdriver																																																												
	<p>Gather the tools required for setup (continued)</p> <div style="display: flex; justify-content: space-between;"> <div style="width: 48%;"> <p><b>Soil Moisture Sensor</b></p> <table border="1"> <thead> <tr> <th>Item</th> <th style="text-align: center;">✓</th> </tr> </thead> <tbody> <tr> <td>Trenching shovel, spade, or flat bar</td> <td></td> </tr> <tr> <td>Water (optional)</td> <td></td> </tr> </tbody> </table> <p><b>Barometric Pressure Sensor</b></p> <table border="1"> <thead> <tr> <th>Item</th> <th style="text-align: center;">✓</th> </tr> </thead> <tbody> <tr> <td>Hook and loop tape</td> <td></td> </tr> </tbody> </table> <p><b>0-5 Volt Input Adapter</b></p> <table border="1"> <thead> <tr> <th>Item</th> <th style="text-align: center;">✓</th> </tr> </thead> <tbody> <tr> <td>Hook and loop tape</td> <td></td> </tr> </tbody> </table> <p><b>3 m or 2 m Tripod with Mast (M-TPA or M-TPB)</b></p> <table border="1"> <thead> <tr> <th>Item</th> <th style="text-align: center;">✓</th> </tr> </thead> <tbody> <tr> <td>1/2 inch wrench</td> <td></td> </tr> <tr> <td>Mast level (Part # M-MLA)</td> <td></td> </tr> <tr> <td>Medium size wire cutters</td> <td></td> </tr> <tr> <td>Crescent wrench</td> <td></td> </tr> <tr> <td>Redimix cement (optional)</td> <td></td> </tr> <tr> <td>Shovel (optional)</td> <td></td> </tr> <tr> <td>All purpose grease</td> <td></td> </tr> <tr> <td>Tape measure</td> <td></td> </tr> <tr> <td>Tie wraps</td> <td></td> </tr> </tbody> </table> </div> <div style="width: 48%;"> <p><b>Temperature/RH or Temp Sensor</b></p> <table border="1"> <thead> <tr> <th>Item</th> <th style="text-align: center;">✓</th> </tr> </thead> <tbody> <tr> <td>Phillips head screwdriver #1 (if sensors are not already installed)</td> <td></td> </tr> <tr> <td>Conduit (optional)</td> <td></td> </tr> </tbody> </table> <p><b>Pulse Input Adapter</b></p> <table border="1"> <thead> <tr> <th>Item</th> <th style="text-align: center;">✓</th> </tr> </thead> <tbody> <tr> <td>Two wire nuts</td> <td></td> </tr> </tbody> </table> <p><b>4-20 mA Input Adapter</b></p> <table border="1"> <thead> <tr> <th>Item</th> <th style="text-align: center;">✓</th> </tr> </thead> <tbody> <tr> <td>Hook and loop tape</td> <td></td> </tr> </tbody> </table> <p><b>Cross Arm (M-CAA) or (M-CAB)</b></p> <table border="1"> <thead> <tr> <th>Item</th> <th style="text-align: center;">✓</th> </tr> </thead> <tbody> <tr> <td>1/2 inch wrench</td> <td></td> </tr> <tr> <td>Crescent wrench</td> <td></td> </tr> </tbody> </table> <p><b>Stake Kit (M-SKA) or (M-SKB)</b></p> <table border="1"> <thead> <tr> <th>Item</th> <th style="text-align: center;">✓</th> </tr> </thead> <tbody> <tr> <td>Sledgehammer</td> <td></td> </tr> <tr> <td>Eye protection—safety glasses</td> <td></td> </tr> </tbody> </table> </div> </div>				Item	✓	Trenching shovel, spade, or flat bar		Water (optional)		Item	✓	Hook and loop tape		Item	✓	Hook and loop tape		Item	✓	1/2 inch wrench		Mast level (Part # M-MLA)		Medium size wire cutters		Crescent wrench		Redimix cement (optional)		Shovel (optional)		All purpose grease		Tape measure		Tie wraps		Item	✓	Phillips head screwdriver #1 (if sensors are not already installed)		Conduit (optional)		Item	✓	Two wire nuts		Item	✓	Hook and loop tape		Item	✓	1/2 inch wrench		Crescent wrench		Item	✓	Sledgehammer		Eye protection—safety glasses	
Item	✓																																																															
Trenching shovel, spade, or flat bar																																																																
Water (optional)																																																																
Item	✓																																																															
Hook and loop tape																																																																
Item	✓																																																															
Hook and loop tape																																																																
Item	✓																																																															
1/2 inch wrench																																																																
Mast level (Part # M-MLA)																																																																
Medium size wire cutters																																																																
Crescent wrench																																																																
Redimix cement (optional)																																																																
Shovel (optional)																																																																
All purpose grease																																																																
Tape measure																																																																
Tie wraps																																																																
Item	✓																																																															
Phillips head screwdriver #1 (if sensors are not already installed)																																																																
Conduit (optional)																																																																
Item	✓																																																															
Two wire nuts																																																																
Item	✓																																																															
Hook and loop tape																																																																
Item	✓																																																															
1/2 inch wrench																																																																
Crescent wrench																																																																
Item	✓																																																															
Sledgehammer																																																																
Eye protection—safety glasses																																																																

✓	Task																																		
	<div style="display: flex; justify-content: space-between;"> <div style="width: 48%;"> <p><b>3 m Mast (M-MPA)</b></p> <table border="1"> <thead> <tr> <th style="text-align: left;">Item</th> <th style="text-align: center;">✓</th> </tr> </thead> <tbody> <tr><td>1/2 inch wrench</td><td></td></tr> <tr><td>Sledgehammer or post driver</td><td></td></tr> <tr><td>Eye protection—safety glasses (if using sledgehammer/post driver)</td><td></td></tr> <tr><td>Mast level (Part # M-MLA)</td><td></td></tr> <tr><td>Redimix cement (optional)</td><td></td></tr> <tr><td>Shovel (optional)</td><td></td></tr> <tr><td>All purpose grease</td><td></td></tr> <tr><td>Tape measure</td><td></td></tr> </tbody> </table> </div> <div style="width: 48%;"> <p><b>1.5 m Mast (M-MPB)</b></p> <table border="1"> <thead> <tr> <th style="text-align: left;">Item</th> <th style="text-align: center;">✓</th> </tr> </thead> <tbody> <tr><td>Sledgehammer or post driver</td><td></td></tr> <tr><td>Eye protection—safety glasses</td><td></td></tr> <tr><td>Mast level (Part # M-MLA)</td><td></td></tr> <tr><td>Redimix cement (optional)</td><td></td></tr> <tr><td>Shovel (optional)</td><td></td></tr> <tr><td>All purpose grease</td><td></td></tr> <tr><td>Tape measure</td><td></td></tr> </tbody> </table> </div> </div>	Item	✓	1/2 inch wrench		Sledgehammer or post driver		Eye protection—safety glasses (if using sledgehammer/post driver)		Mast level (Part # M-MLA)		Redimix cement (optional)		Shovel (optional)		All purpose grease		Tape measure		Item	✓	Sledgehammer or post driver		Eye protection—safety glasses		Mast level (Part # M-MLA)		Redimix cement (optional)		Shovel (optional)		All purpose grease		Tape measure	
Item	✓																																		
1/2 inch wrench																																			
Sledgehammer or post driver																																			
Eye protection—safety glasses (if using sledgehammer/post driver)																																			
Mast level (Part # M-MLA)																																			
Redimix cement (optional)																																			
Shovel (optional)																																			
All purpose grease																																			
Tape measure																																			
Item	✓																																		
Sledgehammer or post driver																																			
Eye protection—safety glasses																																			
Mast level (Part # M-MLA)																																			
Redimix cement (optional)																																			
Shovel (optional)																																			
All purpose grease																																			
Tape measure																																			
	<div style="display: flex; justify-content: space-between;"> <div style="width: 48%;"> <p><b>Grounding Kit (M-GKA)</b></p> <table border="1"> <thead> <tr> <th style="text-align: left;">Item</th> <th style="text-align: center;">✓</th> </tr> </thead> <tbody> <tr><td>1/2 inch wrench</td><td></td></tr> <tr><td>Sledgehammer</td><td></td></tr> <tr><td>Eye protection—safety glasses</td><td></td></tr> <tr><td>Medium size wire cutters</td><td></td></tr> </tbody> </table> <p><b>Solar Radiation Shield (M-RSA)</b></p> <table border="1"> <thead> <tr> <th style="text-align: left;">Item</th> <th style="text-align: center;">✓</th> </tr> </thead> <tbody> <tr><td>1/2 inch wrench</td><td></td></tr> <tr><td>Phillips head screwdriver #1 (if sensors aren't already installed)</td><td></td></tr> </tbody> </table> </div> <div style="width: 48%;"> <p><b>Guy Wire Kit (M-GWA)</b></p> <table border="1"> <thead> <tr> <th style="text-align: left;">Item</th> <th style="text-align: center;">✓</th> </tr> </thead> <tbody> <tr><td>Phillips head screw driver #2</td><td></td></tr> <tr><td>1/2 inch wrench</td><td></td></tr> <tr><td>Medium size wire cutters</td><td></td></tr> <tr><td>Crescent wrench</td><td></td></tr> </tbody> </table> <p><b>Light Sensor Bracket (M-LBB)</b></p> <table border="1"> <thead> <tr> <th style="text-align: left;">Item</th> <th style="text-align: center;">✓</th> </tr> </thead> <tbody> <tr><td>1/2 inch wrench</td><td></td></tr> </tbody> </table> </div> </div>	Item	✓	1/2 inch wrench		Sledgehammer		Eye protection—safety glasses		Medium size wire cutters		Item	✓	1/2 inch wrench		Phillips head screwdriver #1 (if sensors aren't already installed)		Item	✓	Phillips head screw driver #2		1/2 inch wrench		Medium size wire cutters		Crescent wrench		Item	✓	1/2 inch wrench					
Item	✓																																		
1/2 inch wrench																																			
Sledgehammer																																			
Eye protection—safety glasses																																			
Medium size wire cutters																																			
Item	✓																																		
1/2 inch wrench																																			
Phillips head screwdriver #1 (if sensors aren't already installed)																																			
Item	✓																																		
Phillips head screw driver #2																																			
1/2 inch wrench																																			
Medium size wire cutters																																			
Crescent wrench																																			
Item	✓																																		
1/2 inch wrench																																			

## Tasks for Setting up the Tri-pod

- Task 1: Assemble Tripod, page 24
- Task 2: Install Grounding Kit, page 31
- Task 3: Temporarily Install Upper Mast (Optional), page 32
- Task 4: Mount Cross Arm (Optional), page 33
- Task 5: Mount Upper Mast to Lower Mast, page 34
- Task 6: Mount Logger to Upper Mast, page 35
- Task 7: Install Guy Wire Kit (Optional), page 36
- Task 8: Position and Level Sensors, page 38
- Task 9: Final Setup, page 38

### Task 1: Assemble Tripod

There are two types of tripods available: the 2 meter (Part # M-TPB) and 3 meter (Part # M-TPA). The 2 meter instructions begin on this page. The 3 meter instructions begin on page 27.

#### 2 meter tripod/lower mast assembly instructions:

This is an example of a typical 2 meter tripod assembly with a Rain Gauge sensor mounted on separate 1.5 meter mast (the Rain Gauge should be further from the tripod in the field than shown in this example).

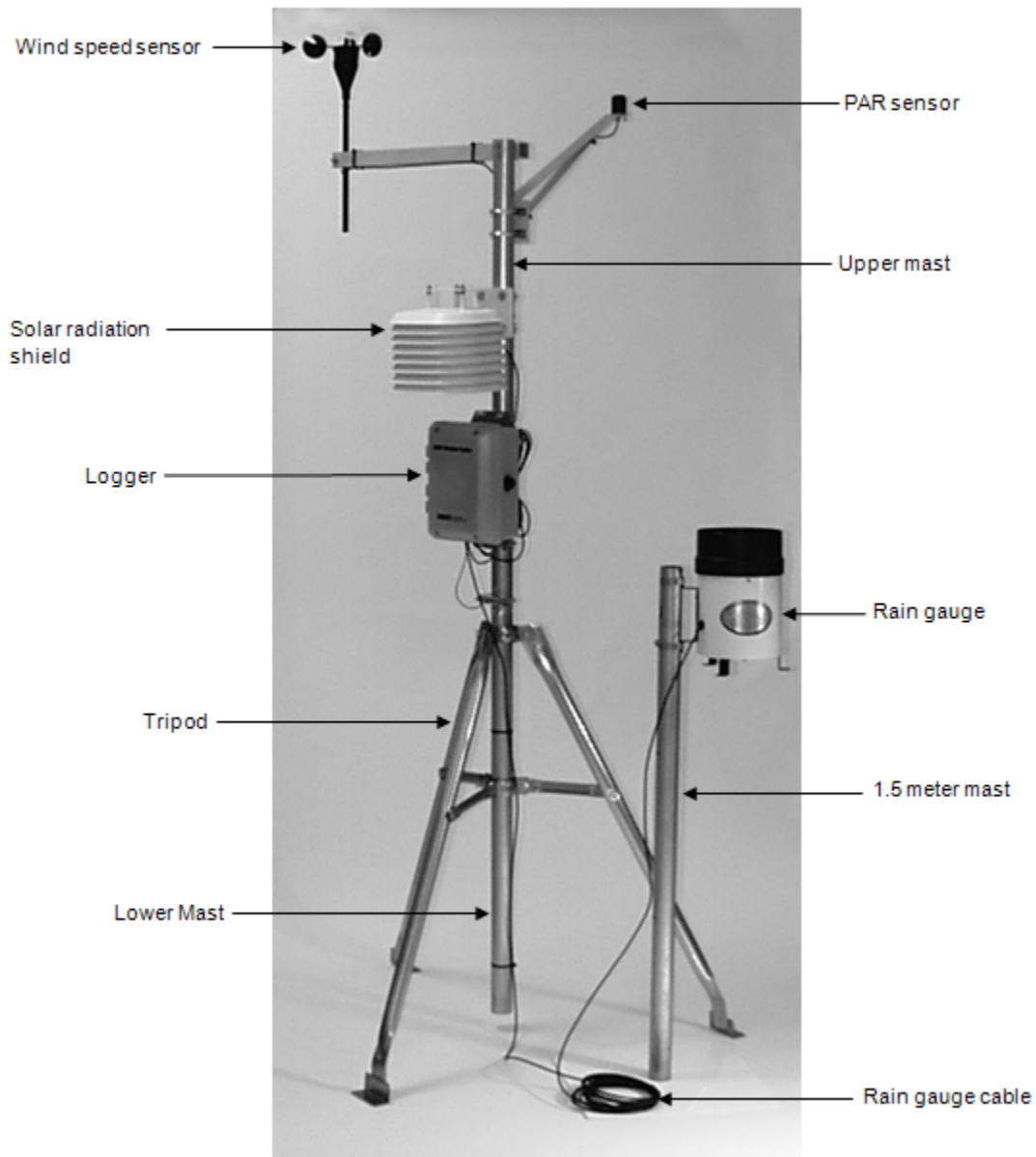

Figure 4: 2 Meter Tri-pod



1. Open the 2 meter tripod and place it in an upright position.
2. Using a 1/2 inch wrench, build six nut and bolt assemblies (5/16-18) like the one shown below.

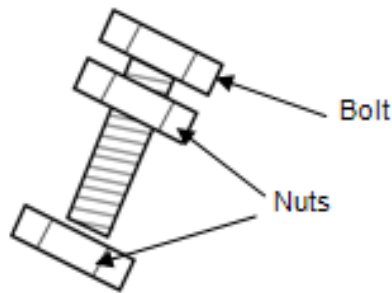

Figure 5: Nut and bolt assembly

3. Take one of the nut and bolt assemblies and insert it through a tri-clamp hole with the bolt head facing outward.
4. Loosely install a nut on the bolt to the inside of the tri-clamp.

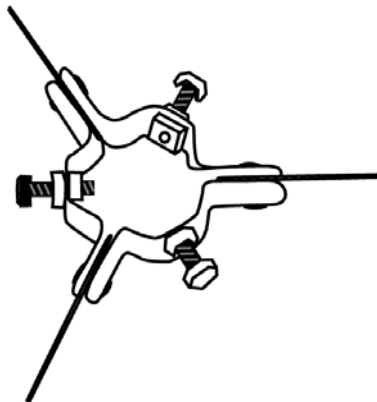

Figure 6: Tri-clamp and bolts

5. Install the remaining five nut and bolt assemblies in the same manner for both upper and lower tri-clamps. Make sure the bolt assemblies on the upper and lower mast tri-clamps leave enough room for the lower mast section to slip through.
6. Slide the lower mast from the top into the tri-clamps with the creased end of the mast facing up. The creases on the lower mast should face north and south.

7. Tighten the tri-clamp bolts by hand so that the mast is temporarily locked into position. **Note:** The lower mast can rest on the ground at this time. You will adjust the height of the lower mast later.

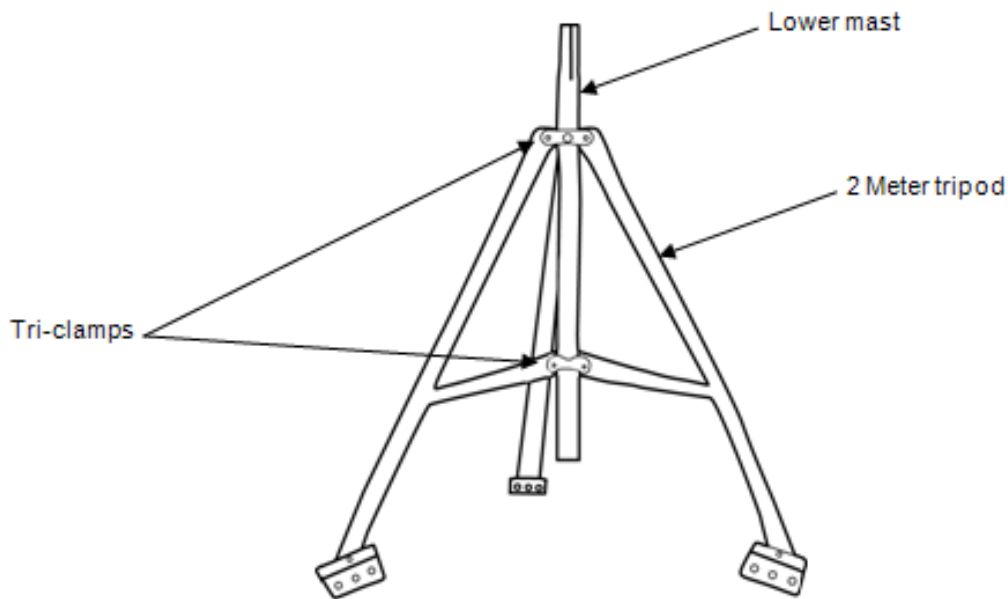

Figure 7: 2 meter tripod - lower mast

8. Because the tripod for the 2 meter configuration has non-adjustable legs, you must verify that the mounting surface area is level. If it is not, use shims or remove soil as needed. You can attach the Post Level (Part # M-MLA) to the mast to verify that it is vertical as you level the surface. You can also use the tri-clamp bolts to fine tune the vertical adjustment later after you adjust the height of the mast.
9. Secure the tripod. Use either the 1/4-inch diameter stake kit (Part # M-SKB) or bolt the tripod to cement pads with 1/4-inch anchors. Install a stake or bolt through one of the holes on each of three tripod feet.
10. If site conditions (high winds, etc.) warrant further stabilization of the tripod, use the Guy Wire Kit (Part # M-GWA). See Task 7: Install Guy Wire Kit on page 36.

**3 meter tripod/lower mast assembly instructions:**

This is an example of a typical 3 meter tripod assembly with a mast-mounted Rain Gauge sensor.

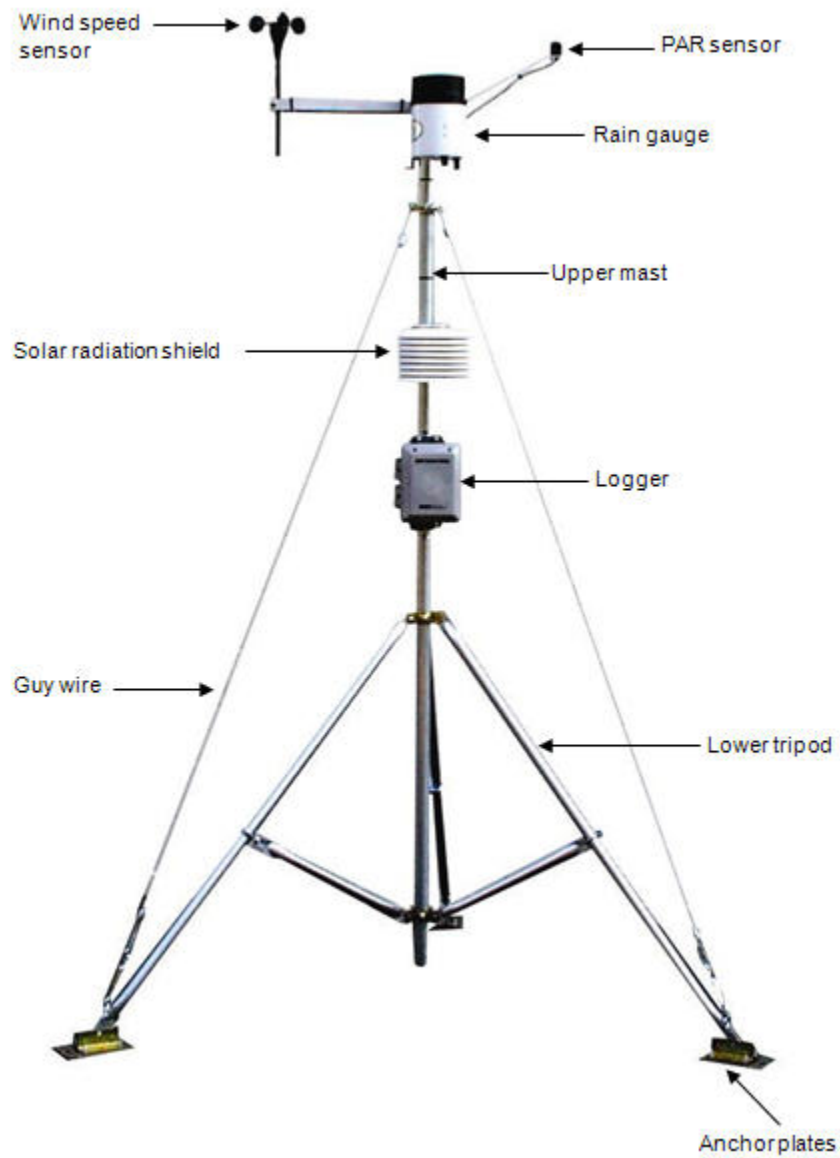

Figure 8: 3 meter tri-pod

1. Using 5/16 inch nuts, attach the three anchor plates to the three tripod foot brackets, with the large holes to the outside. Tighten the nuts securely.
2. Attach the three leg U-bolts with saddle clamps, one each onto the outer legs about 20 cm (8 inches) up from the anchor plates.

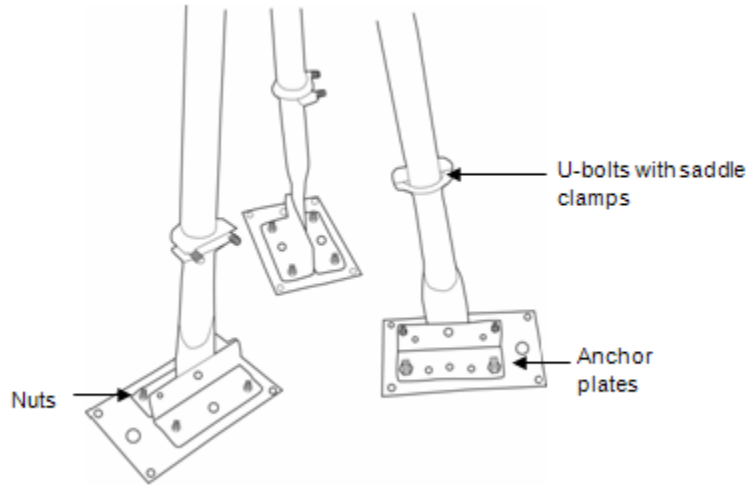

Figure 9: 3 meter lower tripod

3. Open the tripod and place it in an upright position.
4. Unfold the leg brace assembly and place the assembly flat on the ground.

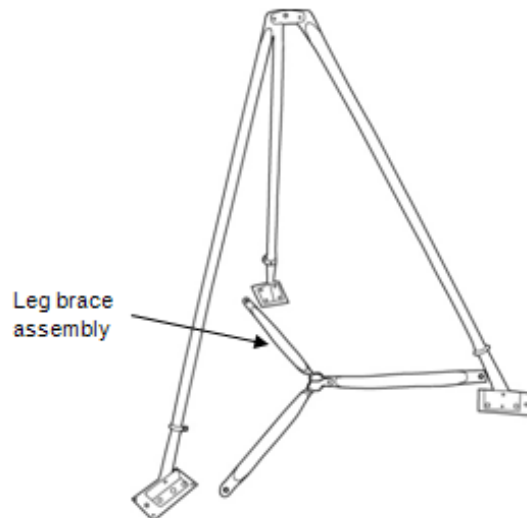

Figure 10: 3 meter tripod leg brace

- Attach each of the three inner legs to each of the leg U-bolt assemblies (5/16-18 inch) using the inner stud of the U-bolt. To attach each inner leg, remove the nut from the inner stud, slide the leg over the stud, and then tighten the nut finger.

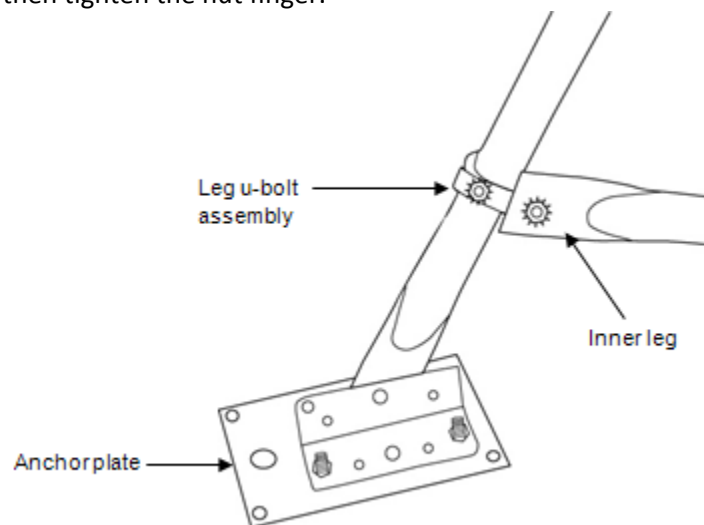

Figure 11: Three meter tripod inner leg

- Loosen the three lock nuts on the bolts on the upper and lower mast tri-clamp assemblies. Back the three bolts out of the upper and lower mast tri-clamp assemblies so that the lower mast section can be slipped down through the upper mast tri-clamps and into the lower mast tri-clamp with the creased end of mast facing up. When the lower mast section is installed, hand-tighten the upper and lower mast tri-clamps.

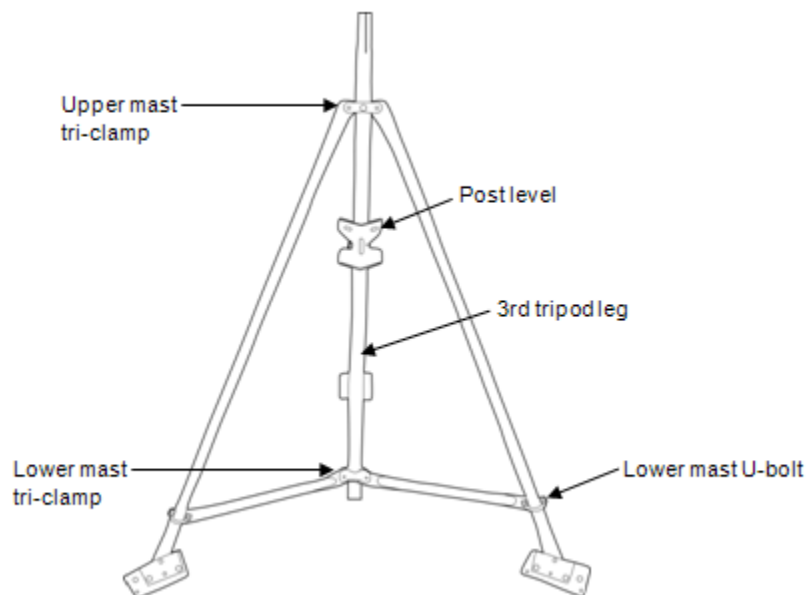

Figure 12: Three meter tripod lower mast

- Install a Post Level (Part # M-MLA) on the lower mast as shown in the previous figure.

8. When the tripod is oriented on the site, secure one of the three tripod legs to its mounting location and tighten the U-bolts on this leg.
9. Adjust the second leg to level in one direction and secure this leg.
10. Use the third leg to adjust the mast close to level.
11. When the mast is close to being level, secure the third leg.
12. Fine tune the mast level by sliding the U-bolts slightly up or down. Tighten all three leg tri-clamps using a 1/2 inch wrench. Again, verify that the mast is level.
13. After checking level and orientation, tighten all upper and lower mast U-bolts and lock nuts.
14. Orient the lower mast creases so they face north and south.
15. Tighten the tri-clamp bolts so that the mast is locked into position. Note the lower mast should be about 8 inches (20 cm) above the ground at this time (assuming that if you are using the wind sensor, you want it to end up at 3 meters or almost 10 feet).

## Task 2: Install Grounding Kit

This section explains how to install the grounding rod from the Grounding Kit (Part # M-GKA) and attach it to the lower mast of either the 2 meter and 3 meter tripods.

1. Attach the ground wire to the lower mast of the tripod using the U-bolt assembly delivered with the grounding kit.
2. Slide the ground rod clamp over the ground rod prior to driving it into the ground. This allows you to work with the clamp before the top of the rod is damaged from impact.
3. Using a sledgehammer, drive the ground rod into the ground as close as possible to the lower mast of the tripod.
4. Attach the ground wire to the ground rod. Cut off excess cable length and discard or recycle.
5. Tighten the clamp bolt.

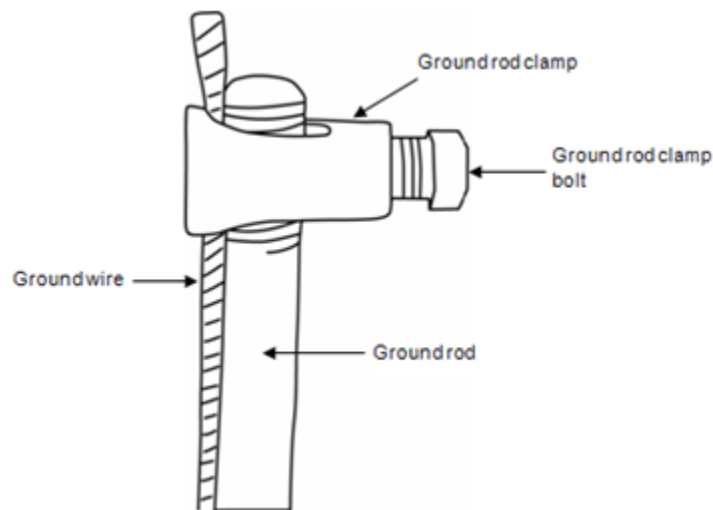

Figure 13: Ground wire attachment

### Task 3: Temporarily Install Upper Mast (Optional)

This section explains how to temporarily attach the upper mast to the tripod base. This allows you to easily work on the upper mast while it is resting on the base of the tripod.

**Note:** If you prefer to permanently install the upper mast at this point because you will be able to reach the fully assembled tower, go to Task 5 and then return to Task 4. Otherwise, follow these temporary steps and then permanently attach the upper mast later.

1. If you will be using the Guy Wire Kit (Part # M-GWA), install the guy wire upper mast clamp about two-thirds up the upper mast. Tighten the clamp by hand to temporarily hold it in place. You will need to adjust it later.
2. Stand the upper mast upright and tie a cable tie to one leg brace and one leg of the tripod using the cable ties supplied. Remove the cable ties after the cross arm and sensors are installed.

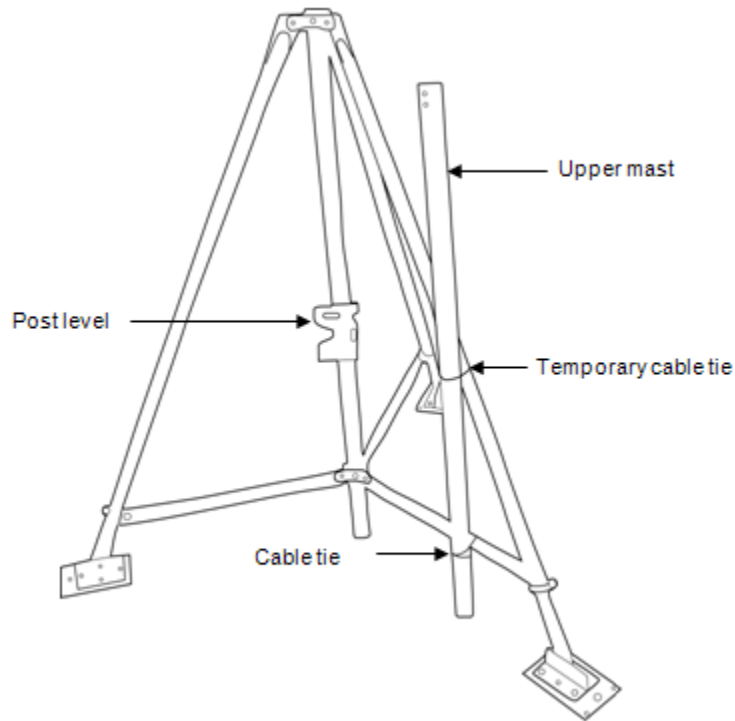

Figure 14: Upper mast (temporary)



### Task 4: Mount Cross Arm (Optional)

Onset recommends that you use the cross arm to mount the Wind Speed or Wind Speed/Direction sensor because it keeps this sensor away from other sensors that could cause wind turbulence or wind shadows. It is also the best way to ensure the sensor is vertical.

#### Steps

1. Attach the cross arm to the upper mast using the two 1/4-20 x 2-3/4 inch hex head bolts. Mount the cross arm on the side opposite the dimple (at the bottom of the upper mast) with the word "TOP" on the upper surface of the cross arm.
2. Pass the two bolts with flat washers on them through the two holes on the cross arm and through the two holes at the top of the upper mast. Install a nylock nut on each bolt. Do not securely tighten the bolts yet.
3. Install the mast plug into the upper mast top with the slot facing down and going over the two bolts. **Note:** After the mast plug is installed, it should be flush with the top of the mast.
4. Tighten the two nuts equally.

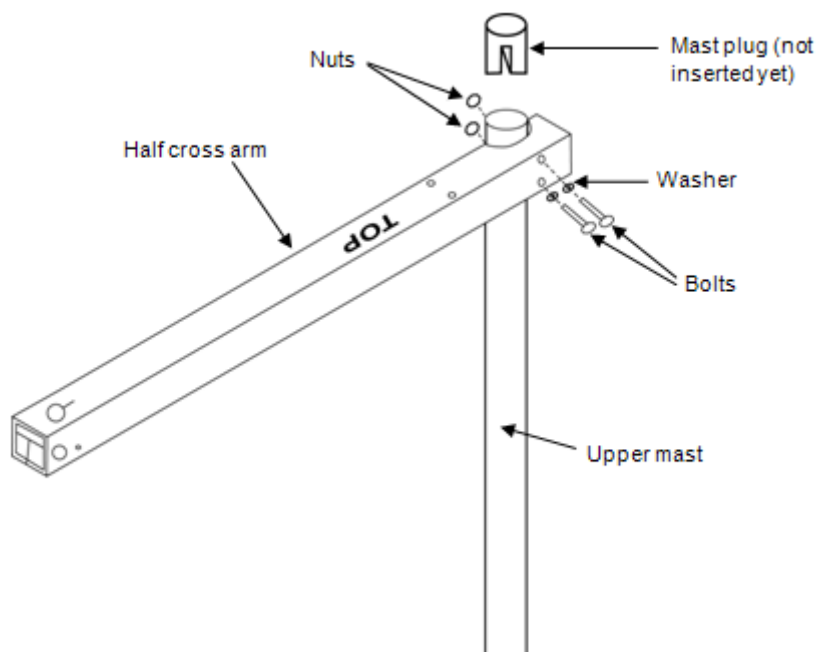

Figure 15: Half cross arm (setup is same for full cross arm)

For directions on mounting the Wind Speed sensor to the cross arm, see the sensor manual.

### Task 5: Mount Upper Mast to Lower Mast

**NOTE:** Onset recommends that two people work together to attach the upper mast to the lower mast.

1. Lightly grease the creased (upper) end of the lower mast.
2. While holding the upper mast securely, cut the cable ties that were temporarily holding the upper mast to the lower mast.
3. Slide the upper mast onto the lower mast with the dimple going into the crease and oriented north if you are in the northern hemisphere, and south if you are in the southern hemisphere.
4. When the upper and lower masts are aligned, install the 1-5/8 inch U-bolt assembly onto the upper mast, placing it just above the dimple (about 2.5 cm or 1 inch from the upper mast bottom). Tighten the clamp.

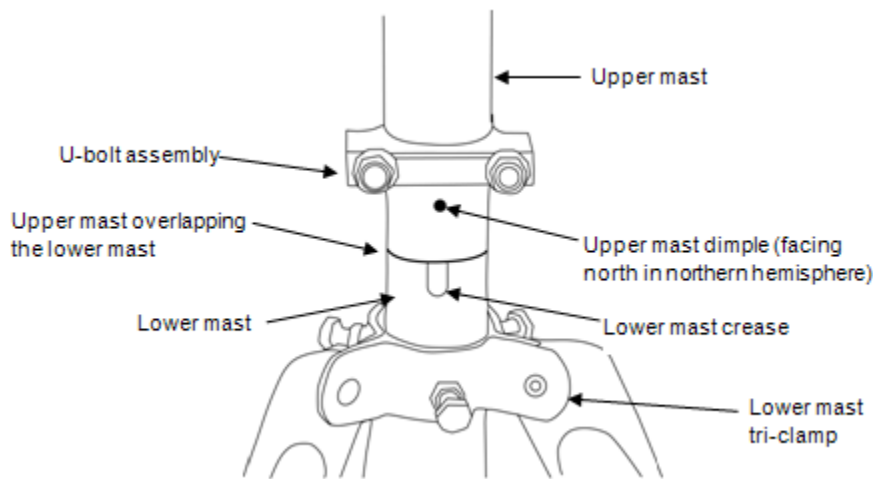

Figure 16: Upper and lower mast assembly

If you are using a Wind Speed sensor and have not attached the cross arm, go to Task 4: Mount Cross Arm (Optional) on page 33.

## Task 6: Mount Logger to Upper Mast

1. Using the two 1-5/8 inch U-bolt assemblies provided, mount the logger enclosure on the lower end of the upper mast in line with the upper mast dimple. The lower housing U-bolt can be placed directly above the U-bolt holding the mast pieces together.

**Note:** When assembling the U-bolts, place the U-bolts around the upper mast, and install the saddle clamp. Place the logger enclosure against the saddle clamps and screw on the top U-bolt nuts only.

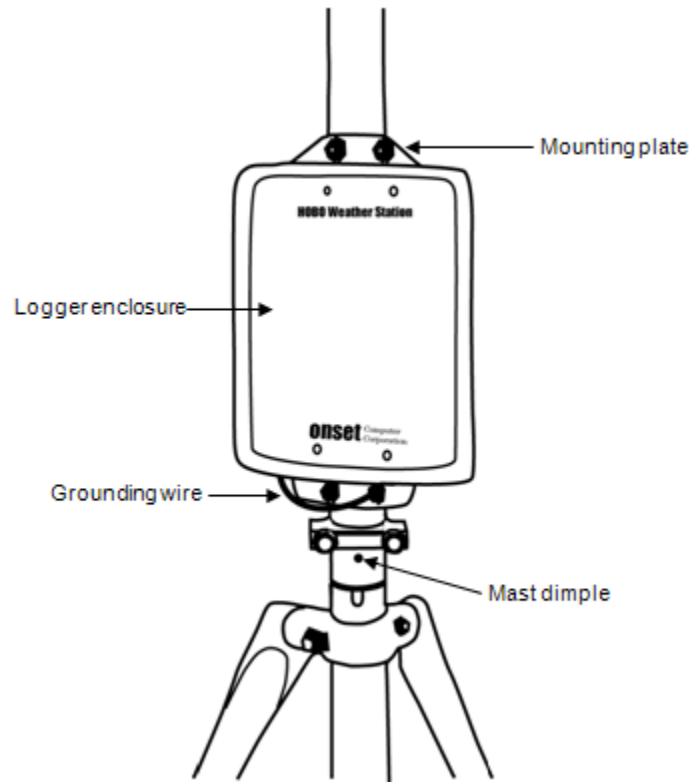

Figure 17: Logger Housing on Mast

2. If you are using the Guy Wire kit, position the logger enclosure so that it will not be in the way of guy wires.
3. Attach the logger's ground wire to the lower housing U-bolt. Screw on the lower U-bolt nuts and then tighten all the U-bolt nuts.

## Task 7: Install Guy Wire Kit (Optional)

**NOTE:** If you are using the 2 meter tripod, you will need to attach the guy wires to three 1/2 inch stakes (Part # M-SKA), which should be spaced evenly around the tripod at a distance of 3 to 4 m (10 to 13 ft) from the mast.

1. If you haven't already done so, attach the upper mast tri-clamp to the upper mast. Orient the eyebolts on the upper clamp so they align with each tripod foot or a 1/2 inch stake.
2. Attach one end of the guy cable to one eyebolt on the upper mast tri-clamp. Open the wire clamp by loosening the screw on it. Place the clamp over the wire and tighten. Leave 2.5 cm (1 inch) of wire protruding from the clamp.

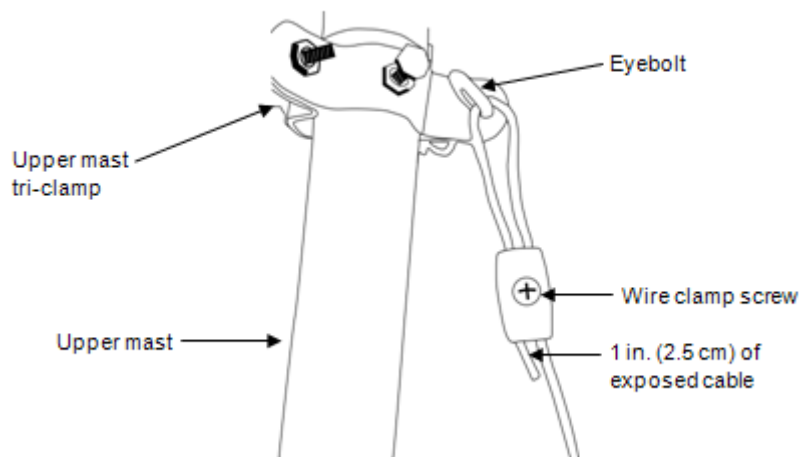

Figure 18: Guy wire attachment

3. Hook one "S" hook and one turnbuckle onto the corresponding stake or leg.

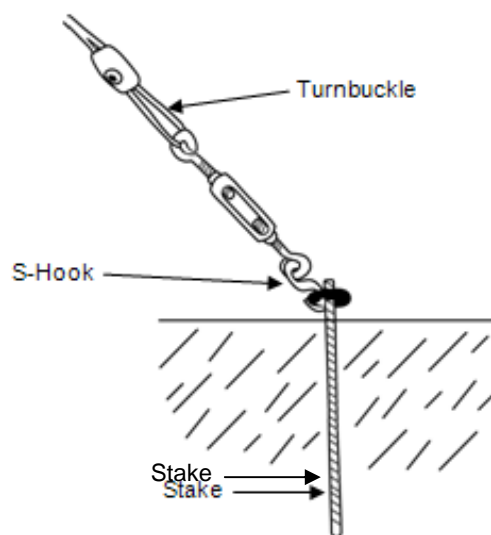

Figure 19: Guying to 1/2 inch Stakes

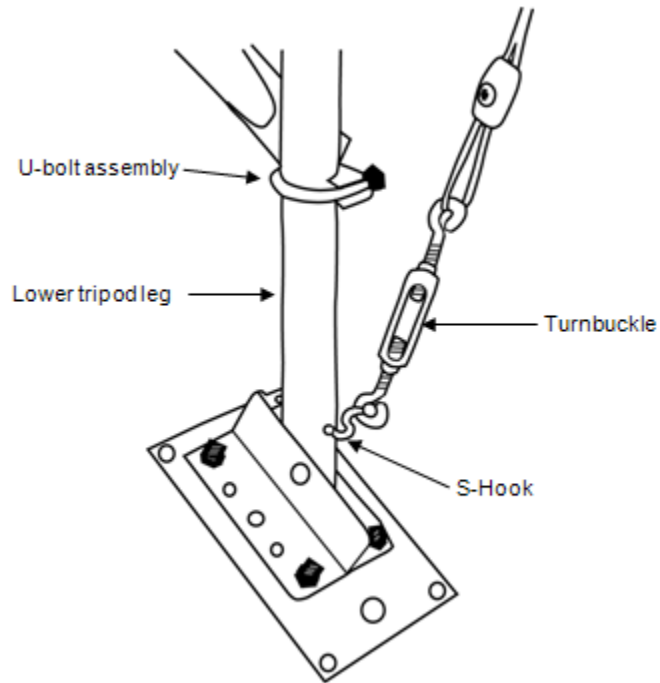

Figure 20: Guying to 3 Meter tripod feet

4. Cut the guy cable so that it can be put through the loose end of the turnbuckle and the wire clamp. Make sure the turnbuckle is extended as shown in the figures before feeding the cable through.
5. Install the hooks, turnbuckles, and cables onto the other two stakes or tripod legs.
6. Tighten the three guy wires evenly by turning the turnbuckles.
7. Attach a Post Level (Part # M-MLA) on the upper mast to maintain the mast at vertical.
8. The guy wires should be taut when the installation is complete.

### Task 8: Position and Level Sensors

Once the upper mast is locked in place and secured, position the sensors at the correct heights and check that the Rainfall sensor and PAR sensors are level. See the sensor manuals for more details.

### Task 9: Final Setup

1. Open the logger enclosure.
2. Pass all the sensor cable ends through the opening on the bottom of the logger enclosure.
3. Plug all the sensors with tabs facing up into the logger board located within the logger enclosure. It does not matter which connector you plug each sensor into. You can use a maximum of 15 channels and 100 meters (328 ft) of smart sensor cable.

**Note:** If you are installing more than ten sensors, you will need to install an adaptor (Part # S-ADAPT) for each additional sensor. The adaptors fit into any of the connectors on the logger board except the upper left connector and the connector second from the bottom on the right.

4. If you have a HOBO U-Shuttle or laptop on site, check current sensor readings to ensure the sensors are all working. For the HOBO Weather Station, note that you cannot check current readings if the logger is waiting for a Button Start or a Delayed Start.
5. Neatly wrap all the sensor cables together and secure to the mast or tripod legs using cable ties.
6. Gather the excess cable and attach the cable ties to the upper mast behind the logger. Leave about a 2 inch (5 cm) drip loop of cable below the logger.

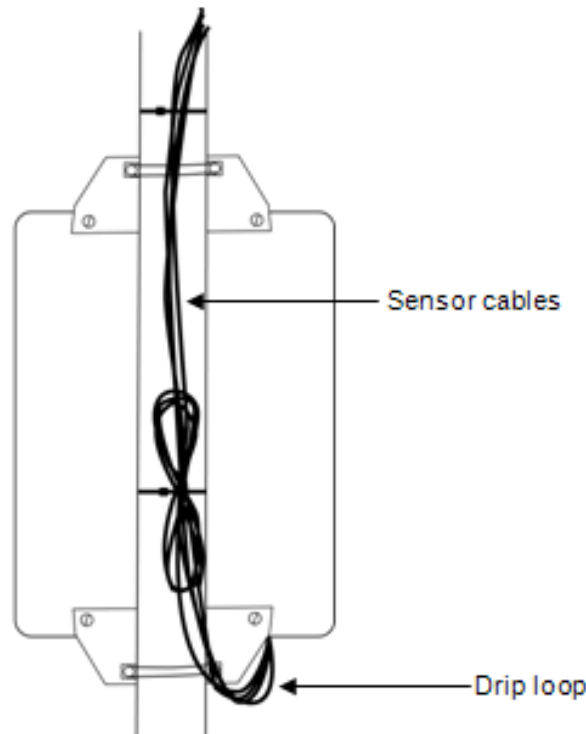

Figure 21: Sensor Cables on Mast

7. Seal logger enclosure (HOBO Weather Station Only).

**This step is especially important if the system is located in a wet environment.**

Once you verify that the cables are secured in the inside of the logger box, take all the cables and push them over to one side of the logger enclosure opening. Using the duct seal, make a ball that is bigger than the logger enclosure opening, stuff the duct seal into the hole from the outside, filling the void between the cables and the housing. This minimizes the possibility of dust, insects, and driving rain getting into the logger housing. Flare out the duct seal on the inside to lock it place.

All cables should be neatly secured to the mast when complete.

**NOTE:** If you are using a HOBO Weather Station in a wet environment, place several dry desiccant packs inside the logger enclosure (remove desiccant pack from its foil pouch before installing)

8. Recheck that all the U-bolts, nuts, and clamps are secure for the entire system.
9. If you are using a Weather Station, launch the logger now. The U-30 is automatically launched when powered-up.
10. Verify that the logger is operating properly. Refer to the logger user manual for LED indications.
11. Close the logger door. For the HOBO Weather Station, tighten the four cover screws.

Congratulations! The HOBO Station setup is complete.





# Section 4: Maintenance

## General Maintenance

Regular maintenance on the Weather Station is essential because it extends the life of the components and helps to ensure the accuracy of recorded measurements. When the logger is deployed in the field, potential damage can come from numerous sources, such as rodents, birds, vandals, and heavy storms. Periodic check-ups in the field allow you to:

- Check that the station is still set up and functioning as you intended
- Check for damage
- Minimize the impact of any damage found

This is particularly important if the logger is being deployed for a long period of time, such as several months or a year. Regular checkups will help ensure that you are continuing to gather data as expected.

## Performing a visual inspection

Periodically perform a visual inspection of the Micro Station tower and logger enclosure. Check that:

- Cables and wires are not damaged, cracked, cut, split, or broken
- All the screws and bolts are tightly secured
- The mast is still level (if in use)
- The ground attachments are fastened to the tripod and logger (if in use)
- There is no excess rust; replace rusty parts as necessary

## Batteries

### Checking Battery Status

There are two ways to check the battery status of the logger:

- Check the Bat Low light on the logger. This light blinks when the battery has 25% or less capacity remaining.
- Check the status with the logger software. For alkaline batteries, the status is displayed in the percentage of capacity remaining. Lithium battery voltage is either listed as “good,” which represents anywhere from 25 to 100% of capacity remaining, or “empty,” which represents 0 to 25% of capacity remaining. Lithium batteries have a relatively flat discharge curve, which means the voltage does not vary much with use until they fail. Because of the uncertainty in capacity, it is recommended that you start new launches with fresh lithium batteries that you know are at 100% rather than relying on old ones.

### Changing Batteries

It is always recommended that you read out the logger before replacing batteries. If you replace the batteries while the logger is logging, it will stop recording data. The data will not be overwritten, however, until the next launch.

Follow these steps to change the batteries.

1. If the logger is currently logging, you will need to stop logging and readout the data. If you do not want to stop the logger, see the next section for instructions on how to use a 9-volt battery to temporarily continue power while changing the batteries.
2. Unscrew the two thumbscrews on the battery door cover and remove the battery door.
3. Remove the old AA batteries.
4. Insert the new AA batteries.
5. Replace the battery door cover and thumbscrews.
6. Launch the logger using the computer or U-Shuttle.
7. Double-check the battery gauge in the logger software to make sure the batteries you installed are full capacity.
8. Replace the battery door cover and thumbscrews.

## Cleaning the Weather Station

The logger enclosure does not require regular cleaning. However, it is recommended that in dusty locations you regularly clean these items:

- **Solar radiation shield.** Wash with soap and water. Dirt/cobwebs obstruct air flow. Discoloration can cause increased solar absorption, which can result in increased errors. Do not get the temperature/RH sensor wet; see the temperature/RH sensor manual for instructions on cleaning it.
- **Light sensor.** Make sure the drain hole is not plugged. If you need to clean the sensor head, see the sensor manual for details and cautions on proper cleaning.
- **Rain gauge.** Make sure there are no leaves or debris in the collector. Make sure the funnel is not plugged; use a cotton swab if necessary to clean.
- **Anemometer on wind speed sensor.** Make sure the cups do not have any dirt/dust/cobwebs. Spray bearing with a light oil.
- **Anemometer on wind speed and direction sensor.** Apply a couple drops of 3-in-1 oil or other motor oil to the bearings on the vein and anemometer.
- **Logger enclosure.** Remove dust with compressed air. Do not get water inside the enclosure.
- **Tower.** Hose with fresh water if necessary.

## Verifying Sensor Accuracy

For most sensors, Onset recommends that you test sensor measurement accuracies once a year. Onset Computer can verify the accuracy of all sensors and recalibrate applicable sensors. For more details on verifying sensor accuracy, refer to the user manual included with the sensors.



## Section 5: Reference

### Memory

The logger uses non-volatile memory, which means it retains data indefinitely once power runs out. Specifically, the logger uses a high-capacity Flash memory to store data, which can retain the data even when the batteries are removed. This type of memory is very durable.

If the logger dies in the field from dead batteries, replace them and read out the logger immediately. Do not relaunch the logger until the data has been recovered. If your logger is damaged, contact Onset Computer because there is a chance the data can be recovered.

The logger contains 512K bytes of memory. Up to 10K of this memory is used to store the launch configuration and user notes, leaving at least 502K bytes for data storage. The logger software automatically estimates how long the logger will record data until the memory is full (the run time) based on the logging interval and the number and type of sensors connected. In general, adding sensors decreases running time while increasing the logging interval increases running time. In most applications, battery life limits the duration of the data logging before memory capacity.

The following figure shows the expected run time for several logging intervals based on the total number of bits in place, which is determined by adding together the bits per sample for each sensor measurement parameter in your system. For example, a logger with the following sensors is using 70 total bits.

4 Temperature	X	8	=	32
1 Wind Speed	X	16	=	16
1 PAR	X	10	=	10
1 Rain Gauge	X	12	=	12
<hr/>				
Total number of bits				70

At a logging interval of 5 minutes, the memory run time for a Weather Station using 70 bits would be approximately 200 days (based on Figure 5). See the sensor's manual for the number of bits each type of sensor uses.

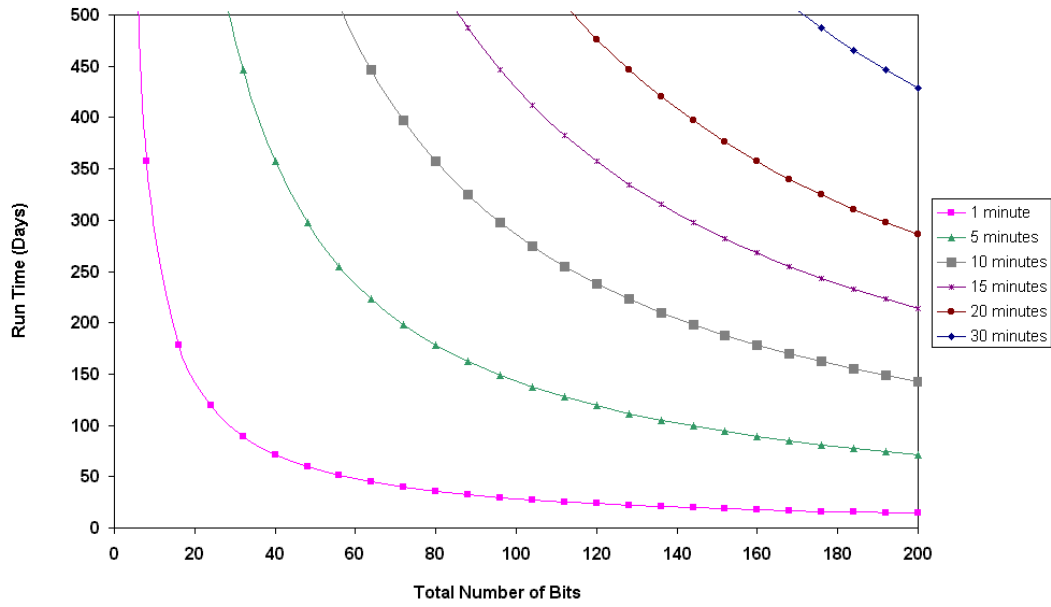

Figure 1: Memory run time

## Time Accuracy

When you launch a logger, its clock is set by the host computer's time and time zone offset from UTC. (UTC, or Coordinated Universal Time, is similar to Greenwich Mean Time.) The time zone offset makes it possible to determine objective, non-local time. This prevents conflicts and confusion when you relaunch a logger with a shuttle that may have been launched in a different time zone, or before a Spring or Fall time change.

Once the logger is logging, it will keep fairly accurate time. However, the following may cause errors with time reporting:

- **Host clock error.** The most likely source of error is an incorrect time, or time zone setting, on the computer that launched the logger. Make sure the clock on your computer is set to the correct date and time before launching the logger. One accurate resource is <http://www.nist.time.gov>.
- **Launch time loss.** The logger may lose up to two seconds when it is launched. This is a one-time error that occurs as part of the start-up sequence and cannot be avoided.
- **Clock drift.** The long-term time accuracy is a function of temperature. The worst-case error is  $\pm 8$  parts per million (PPM) a week at  $25^{\circ}\text{C}$ , which is about 5 seconds per week. The error increases as the temperature deviates from  $25^{\circ}\text{C}$  (see the figure below). If the temperature were a constant  $-20^{\circ}\text{C}$ , the logger time error could be as much as 35 ppm (21 seconds per week).

The following graph shows the worst-case time error.

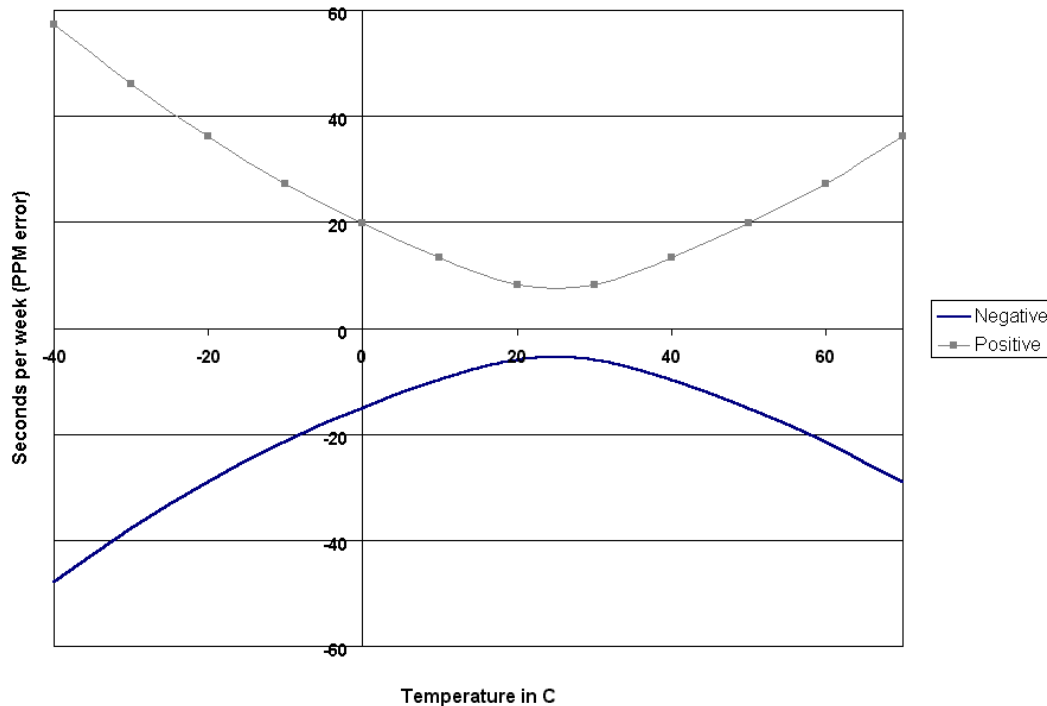

Figure 2: Worst-case time error

## **Resetting the Clock**

Reading out the logger and relaunching it will reset the logger's clock. This is useful when your logger has been running for a while and its clock needs to be reset. Make sure the computer clock is set accurately before relaunching.

1. Exit HOBOWare Pro and correct the computer's clock.
2. Restart HOBOWare Pro.
3. Read out the logger, if you have not done so already.
4. Relaunch the logger.



## Section 6: Troubleshooting

This section lists common problems you may encounter with the Weather Station and possible resolutions.

Problem	Resolution
Individual sensors are not found or are missing in the logger software launch screen	<ul style="list-style-type: none"> <li>• If a sensor is removed and then immediately re-inserted, it may not be auto-detected and therefore will not appear in the launch screen. Click the “Reset” or “Add Sensor” button in the launch screen.</li> <li>• Check for a loose connection between the sensor and the logger.</li> <li>• Make sure you haven’t exceeded the maximum of 15 sensors connected to the logger. Note that some sensors are dual sensors and count as two, such as the temperature/RH sensor and the wind speed sensor. If you have more than 15 sensors, remove one or more until you have 15 or less.</li> <li>• Make sure you haven’t exceeded 100 meters (328 ft) of network cable.</li> </ul>
All sensors are missing in the logger software launch screen	<ul style="list-style-type: none"> <li>• Remove all but one sensor, then check if the sensor appears in the launch screen. Continue to remove and re-insert the sensors one at a time until you find the bad sensor. If you find a bad sensor or if none of the sensors communicate, contact your Onset dealer or Onset Computer Corporation.</li> </ul>
The error status light is blinking	<ul style="list-style-type: none"> <li>• If the error light is blinking in conjunction with the OK light, there was a communication failure. The system has recovered, but you may have an intermittent problem. Try checking the sensors one at a time to make sure they are all communicating. If you find a bad sensor or if no sensor communicates, contact your Onset dealer or Onset Computer Corporation.</li> <li>• If the error light is the only light blinking, then at least one sensor is currently not communicating. Immediate investigation is recommended. Look for a loose connection, which could cause bad electrical contact with a sensor. If found, remove the offending sensor and check its wires and connector for damage and/or signs of moisture.</li> <li>• In general, it is recommended that you read out any data when this light is blinking, investigate the problem, and re-launch the logger.</li> </ul>
The battery low light is blinking after the batteries were replaced	<ul style="list-style-type: none"> <li>• Check the polarity; make sure the batteries are installed properly. It is possible one cell is reversed.</li> <li>• Make sure you are using the correct battery type. The logger uses four 1.5 volt AA alkaline or lithium batteries. The type must be specified in the launch screen for the correct battery status.</li> <li>• Make sure you aren’t using a combination of alkaline and lithium batteries. Never mix battery types.</li> <li>• Check the battery expiration date; make sure it is at least two years from the current date. Batteries can lose significant capacity if</li> </ul>

Problem	Resolution
	<p>stored at elevated temperatures.</p> <ul style="list-style-type: none"> <li>• Check the voltage with a voltmeter. Alkaline batteries should be at least 1.5 volt per cell when new; lithium batteries should be 1.6 volt per cell.</li> </ul>
Batteries die prematurely	<ul style="list-style-type: none"> <li>• Check for excessive moisture in the logger enclosure. Severe and/or repeated condensation in the logger enclosure can lead to short circuits and battery failure. It may be necessary to add additional sealing and/or desiccant to the logger enclosure to prevent condensation.</li> <li>• Check to make sure that both the logging and sampling intervals are set for at least 1 minute or greater. Sampling/Logging intervals faster than 1 minute will rapidly deplete the battery. See the section on <i>Estimating battery life</i> on page 14 for more details.</li> <li>• Check for damaged wiring and/or sensors. Damaged cables or connectors can result in complete or partial short circuits that will rapidly drain batteries.</li> </ul>
No status lights are flashing	<ul style="list-style-type: none"> <li>• The lights are very faint. In direct sunlight, shield the sun and check again.</li> <li>• Make sure the batteries are not dead. Batteries should have at least 1 volt per cell.</li> <li>• The memory may be full. Read out (offload) data from the logger and re-launch.</li> <li>• The logger may not have been launched. Check the status with the logger software.</li> </ul>
OK status light is not flashing	<p>Make sure the logger is launched. If you configured the logger to launch with a delayed start, check the date and time you selected and make sure the Delay Start light is flashing. If you configured the logger to launch with a button start, press and hold the button on the logger for a second until all the lights flash.</p>
Data file contains errors	<p>If you are missing data for a particular sensor, check that the sensor was properly installed. Remove and re-insert the sensor, and check that it can take current readings. If you find that it is not communicating, it may be a bad sensor. Contact your Onset dealer or Onset Computer Corporation.</p>
Data file can't be opened	<p>The data file may have become corrupted. In rare circumstances, the data file may have errors. Offload the logger again and try opening the file again. If that does not work, contact your Onset dealer or Onset Computer Corporation.</p>
Logger is not found	<ul style="list-style-type: none"> <li>• Check and replace the batteries.</li> <li>• Check communications cable connections.</li> </ul>



Onset Computer Corporation  
470 MacArthur Blvd.  
Bourne, MA 02532