



FoodSaver®

THE #1 VACUUM SEALING SYSTEM



**User Manual
& Recipe Book**
for V4800 series appliances

www.foodsaver.com 1-877-777-8042

Important Safeguards

For your own safety, always follow these basic precautions when using a FoodSaver® appliance:

1. Read the User Manual carefully for operating instructions.
Read all instructions in this manual before use.
2. Do not use appliance on wet or hot surfaces, or near a heat source.
3. Caution: To protect against electric shock, do not immerse any part of appliance, power cord or plug in water or other liquid. Unplug from outlet when not in use and before cleaning.
4. To disconnect, unplug power cord from electrical outlet.
Do not disconnect by pulling on cord.
5. Do not operate appliance with a damaged power cord or plug.
Do not operate appliance if it malfunctions or is in any way damaged.
For details, contact Consumer Services at number listed below.
6. Use appliance only for its intended use.
7. Closely supervise children when using any electrical appliance.
Do not allow appliance to be used as a toy.
8. Do not place on or near a hot gas or electric burner, or heated oven.
Extreme caution must be used when moving products containing hot liquids.
9. Wait 20 seconds between seals to allow appliance to cool.
10. Caution: Place cord where the cord cannot be pulled, cause user to be entangled with the cord, or cause the product to be overturned.

**For Household Use Only
SAVE THESE INSTRUCTIONS**

Table of Contents

Important Safeguards	2
Welcome to FoodSaver® Vacuum Sealing System	4
Features of Your FoodSaver® Appliance	4
How to Make a Bag from a FoodSaver® Vacuum Sealing Roll	8
How to Vacuum Seal with FoodSaver® Vacuum Sealing Bags	9
Removing Air from a Bag	10
Using FoodSaver® Vacuum Sealing Accessories	10
Using PulseVac™ Control Feature.....	11
Emptying Drip Tray	11
Marinating with your FoodSaver® Appliance	12
Care and Cleaning	13
Guidelines for Vacuum Packaging.....	14
Storage Guide - Meat, Cheese, Vegetables, Fruits.....	16
Storage Guide - Baked Goods, Coffee, Snacks and Liquids	17
Trouble-Shooting.....	18
Recipes for your FoodSaver® Appliance	19
Warranty.....	23

Important Tips

- Vacuum packaging is NOT a substitute for the heat process of canning. Perishables still need to be refrigerated or frozen.
- For best results, use only with FoodSaver® Bags, Containers and Accessories.
- During the vacuum packaging process, small amounts of liquids, crumbs or food particles can be inadvertently pulled into the Vacuum Channel. Empty the Drip Tray after each use.
- Avoid overfilling, always leave at least 4 inches (10.16 centimeters) of bag material between bag contents and top of bag. This allows room for the bag material to cinch tightly against the food and prevents the bag from pulling out of the vacuum channel during the sealing process. Then leave at least one additional inch of bag material for each time you plan to reuse bag.
- Do not create your own side seams for a FoodSaver® Bag. These bags are manufactured with a special side seam, which is sealed all the way to the outer edge.
- To prevent wrinkles in the seal when vacuum packaging bulky items, gently stretch bag flat while inserting bag into vacuum channel and continue to hold bag until vacuum pump starts.
- When you are vacuum packaging items with sharp edges (dry spaghetti, silverware, etc.), protect bag from punctures by wrapping item in soft cushioning material, such as a paper towel. You may want to use a canister or Mason jar instead of a bag.
- When using accessories, remember to leave one inch of space at top of canister or container.
- Pre-freeze fruits and blanch vegetables before vacuum packaging for best results. See “Guidelines for Vacuum Packaging” section.
- 120v Appliances Only: The FoodSaver® appliance has a polarized plug (one blade is wider than the other). To reduce risk of electrical shock, this plug is intended to fit in a polarized outlet only one way. If plug does not fit fully in the outlet, reverse plug. If it still does not fit, contact a qualified electrician. Do not modify plug in any way.
- Caution: A short power cord is provided to reduce risks from entanglement or tripping over a longer cord. An extension cord may be used when marked electrical rating is no less than electrical rating of this appliance. All cords should not drape over counter or tabletop where cords can be tripped over or pulled on unintentionally, especially by children.

Welcome to FoodSaver® Vacuum Sealing System

Congratulations...

You are about to enjoy the freshness benefits of FoodSaver®, The #1 Selling Brand of Vacuum Sealing Systems. For years, the FoodSaver® Vacuum Sealing System has helped millions of households keep food fresh longer in the refrigerator, freezer and pantry. The FoodSaver® system is designed to remove air and extend freshness up to five times longer than conventional storage methods. Keep your FoodSaver® appliance on your countertop, and you'll soon discover its convenience and versatility.

Free Gift with Registration!

Register now and you'll receive a free gift. It's our "thanks" to you for being a FoodSaver® brand customer.

Register online at www.foodsaver.com/register. You'll have access to special sale items for online registrants only!

Questions?

Contact customer service at
877-777-8042
or visit www.foodsaver.com.

Do not return this product to place of purchase.

Features of Your FoodSaver® Appliance

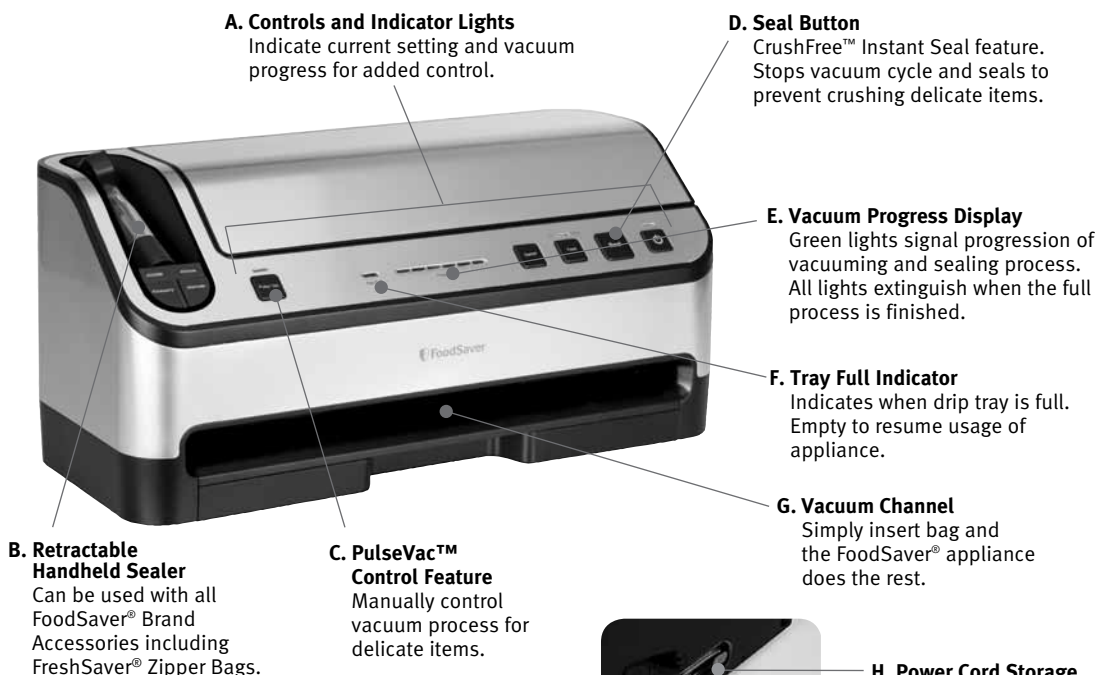



- I. Appliance Door**
Opens to access Built-in Roll Holder and Cutter.
- J. Built-in Roll Holder**
For storage of FoodSaver® Vacuum Sealing Rolls.
- K. Roll Cutter Bar**
Simplifies making custom-sized bags.
- L. Bag Cutter**
- M. Auto Bag Sensing**
Simply insert open end of bag into the vacuum channel and the machine will sense and grasp the bag, vacuum, seal and shut-off automatically.



- N. Extra-wide Sealing Strip with Non-stick Coating**
Provides extra secure, air-tight seal that's two times wider.
- O. Lower Gasket (non-removable)**
- P. Removable Drip Tray**
Catches overflow liquids and contains Food Sensors to detect liquid.

Control Panel of Your FoodSaver® Appliance

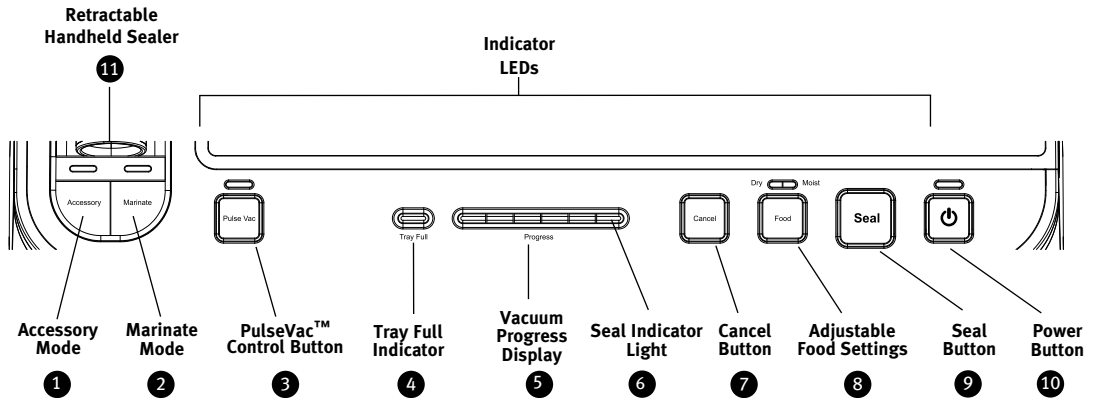

1 ACCESSORY MODE BUTTON

Press to achieve best vacuum for canisters and accessories.
Push Accessory Mode Button **1** to begin vacuum process.
Motor will run until Vacuum Sealing Process is complete.

2 MARINATE MODE BUTTON

A ten minute predetermined sequence of vacuum pulse to rest ratio allowing foods to get optimum flavor infusion in the least amount of time.
(See “Marinating with your FoodSaver® Appliance” section on page 12.)

3 PULSEVAC™ CONTROL BUTTON

Use to manually control the vacuum process and avoid crushing delicate items.
See “Using PulseVac™ Control Feature” section on page 11 for further information.

4 TRAY FULL INDICATOR LIGHT

During the vacuum sealing process, small amounts of liquids, crumbs or food particles can be inadvertently pulled into the Drip Tray (P). When excess liquid fills the Drip Tray, the unit will turn off and the Tray Full Indicator **4** will activate. To resume normal operation, remove the Drip Tray, empty liquid, wash in warm soapy water or place in top rack of dishwasher. Dry completely and place Drip Tray back into appliance. (See “Care and Cleaning” on page 13.)

5 VACUUM PROGRESS DISPLAY

Displays vacuum levels as the bag or canister is evacuated.

6 SEAL INDICATOR LIGHT

Constant Red light indicates sealing process is engaged.
(Flashing light indicates error. See “Trouble-Shooting” Section on page 18 for more information.)

7 CANCEL BUTTON

Immediately halts the current function and opens the Vacuum Channel.

8 ADJUSTABLE FOOD SETTINGS BUTTON

For optimal vacuuming and sealing of moist or juicy foods, press the Adjustable Food Settings Button **8** until the Moist Indicator Light is illuminated. Choose the dry food setting for foods without liquid. The Moist Food Indicator light will flash when Food Sealing Sensors automatically detect any moisture or liquid in the drip tray (**P**).

NOTE: Appliance will default to Dry setting upon pressing the Power Button or when power has been interrupted, unless liquid is detected in the Drip Tray. (See “Care and Cleaning” section of this User Manual on page 13.)

9 SEAL BUTTON

This button has four uses:

1. CrushFree™ Instant Seal feature-
Press to immediately stop the vacuum process and begin sealing the bag. This prevents crushing delicate items such as bread, cookies and pastries.
2. Press to create a seal when making bags from a FoodSaver® Roll.
3. Press to create a seal on mylar type bags (such as a potato chip bag) to keep food sealed air-tight.
4. Press during PulseVac™ mode to seal bag.

10 POWER BUTTON

Press the power button to begin. The Power Indicator and Food Indicator lights will become illuminated. After Vacuum Sealing, press Power Button to turn appliance Off.

Note: After 12 minutes of non-use, the appliance will turn Off automatically.

11 RETRACTABLE HANDHELD SEALER



1. Accessory Button
2. Marinate Button

How to Make a Bag from a FoodSaver® Vacuum Sealing Roll

HOW TO

1. Open appliance door (I) and place roll into Roll Holder (Fig. 1). For best results, insert roll with material flap down.
2. Lift up Roll Cutter Bar (K) and place bag material beneath the cutter bar (Fig. 2).
3. Pull out enough bag material to hold item being vacuum sealed, plus 4 inches (10.16 centimeters). Lower the Roll Cutter Bar and slide Bag Cutter (L) across the Cutter Bar (Fig. 3).
4. Press Seal Button (D). Red Seal Indicator Light (6) will illuminate (Fig. 4).
5. Using two hands, slowly insert open end of bag, curl down, into Vacuum Channel (G) until clamp motor starts.
6. When red Seal Indicator Light (6) turns off, sealing is complete. You may remove bag from the Vacuum Channel (G).
7. You now have one sealed end (Fig. 5).
8. Now you are ready to vacuum seal with your new bag (see next page).

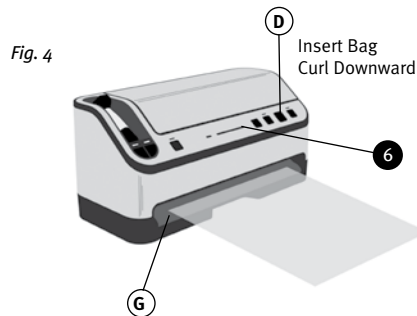
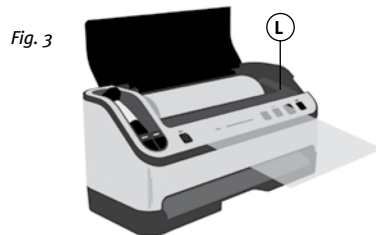
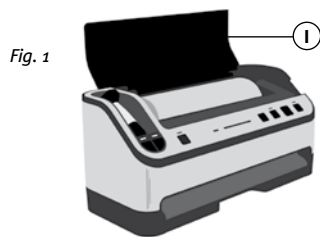

How to Vacuum Seal with FoodSaver® Vacuum Sealing Bags

1. Begin with a FoodSaver® Vacuum Sealing System Bag (or create a bag as described in the “How to Make a Bag from a Roll” section on page 8).
 2. Place item(s) in bag, allowing at least 4 inches (10.16cm) of space between bag contents and top of bag (Fig. 1). The extra space is required to allow the bag to seal tightly around contents.
 3. OPTIONAL: If you wish to customize the vacuum sealing process you may select Food Setting **8** (Fig. 2). Default setting is Dry Food. See page 7 for more information.
 4. Your new FoodSaver® System Automatically Vacuums and Seals. **To Vacuum: DO NOT PRESS THE SEAL BUTTON.** Using two hands, slowly insert open end of bag, curl down, into Vacuum Channel (**G**) (Fig. 3/4).
 5. Continue to hold bag until vacuum pump starts. You may now release bag. The Vacuum Progress lights **5** will illuminate.
- NOTE:** To prevent crushing delicate items, you may press Seal Button (**D**) at any time to begin automatic sealing process.
6. When red Seal Indicator Light **6** turns off, remove bag (Fig. 5). Refrigerate or freeze if needed.

NOTE: Wait at least 20 seconds between seals to allow appliance to properly cool.

NOTE: Appliance should be used in vertical orientation and not laid on its back.

NOTE: Appliance will time out after a couple of minutes if vacuum cannot be reached.

Go to www.foodsaver.com for additional hints, tips, instructional videos and information about how to purchase FoodSaver® parts and accessories.

Fig. 1

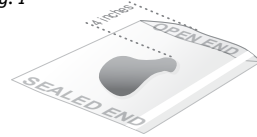

Fig. 2

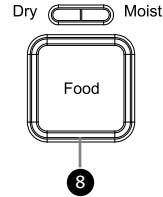

Fig. 3



Fig. 4



Insert Bag
Curl Downward

**AUTOMATICALLY
SEALS!**
Do Not Press Button!

Fig. 5



Removing Air from a Bag

Avoid wrinkles when inserting the bag into the Vacuum Channel (G).

Wrinkles in seal may cause leakage and allow air to return into bag. To eliminate any wrinkles while inserting bag, gently slide bag curl down into the Vacuum Channel (G), and hold bag with two hands gently stretching bag flat until vacuum pump begins. If you find wrinkles after sealing bag, simply cut bag open and vacuum seal again.

If motor runs for more than 30 seconds without stopping, consider the following:

If you are vacuum sealing with a bag, make sure one end of the bag is properly sealed. (See “How to Make a Bag From a Roll” on page 8.)

If vacuum sealing with an accessory, check Handheld Sealer connections to ensure a tight fit.

Using FoodSaver® Vacuum Sealing Accessories

FreshSaver® Zipper Bags

1. Place food into Zipper Bag. Make sure not to put any food under valve. Press zipper closed with finger while bag is lying down on a flat surface.
2. Pull Retractable Handheld Sealer from appliance. Place end over the gray valve on bag.
3. Push accessory button to begin vacuum process. Motor will run until vacuum process is complete.

Containers

1. Prepare container according to FoodSaver® Accessory Guidelines, which are included with accessory purchases.
2. Pull Retractable Handheld Sealer from appliance. Place end over gray valve on container.
3. Push accessory button to begin vacuum process. Motor will run until vacuum process is complete.

Fig. 1

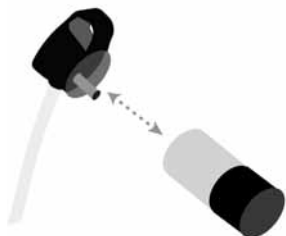

Canisters

1. Prepare canister according to FoodSaver® Accessory Guidelines, which are included with accessory purchases.
2. Pull Retractable Handheld Sealer from appliance and remove clear bottom portion of handheld from top handle. Insert the end into the port on accessory. Twist tab while inserting to ensure a tight fit.
3. Push Accessory Button to begin vacuum process. Motor will run until vacuum process is complete. (To Marinate, follow instructions found in Marinating with your FoodSaver® Appliance section of this Guide on page 12.)
4. When motor turns off, gently twist and remove Handheld Sealer from accessory.
NOTE: if you are using a canister with large white knob, rotate knob clockwise to the “Closed” position, then gently twist and remove Handheld Sealer from accessory.
5. To test vacuum, simply tug on accessory lid. It should not move.
6. To retract Handheld Sealer, while holding unit, gently pull on hose end to allow hose to retract into appliance. Do not release freely as it may damage the Handheld Sealer.

IMPORTANT: When pulling hose Do Not extend beyond red line marked on hose.

Using PulseVac™ Control Feature

Use the PulseVac™ Control feature to manually control the vacuum process and avoid crushing delicate items.

1. Place item(s) in bag, allowing at least 4 inches (10.16 centimeters) of space between bag contents and top of bag.
2. Press the PulseVac™ button **3**. PulseVac™ LED will be lit to indicate PulseVac™ mode.
3. Insert open end of bag into Vacuum Channel **(G)**. The clamp will close to secure the bag. The PulseVac™ LED will now flash.
4. Push and hold the PulseVac™ Button **3**. The vacuum pump will run when the PulseVac™ Button is held down. Release the PulseVac™ Button to stop the vacuum process. This will allow you to adjust the contents of the bag for better control of the vacuum sealing process. Repeat pushing the PulseVac™ Button until desired amount of air has been removed.

NOTE: If the vacuum pump stops engaging after several pushes of the PulseVac™ Button, it means the maximum vacuum has been reached. Do not continue to push the PulseVac™ Button.

5. Press Seal Button **9** to seal the bag and end the PulseVac™ mode.

NOTE: The bag will be sealed automatically if you reach max vacuum.

6. When the red Seal Indicator Light **6** turns off, remove bag. Refrigerate or freeze if needed.

Emptying Drip Tray

This FoodSaver® model comes with a convenient, pull-out drawer to access the Drip Tray **(P)**.

1. Simply slide it out, then pull up on side handles of Drip Tray to remove.
2. Drip Tray can be emptied and washed with warm, soapy water or in the dishwasher on the top rack.



Marinating with your FoodSaver® Appliance

Your FoodSaver® Vacuum Sealing System has a special Quick Marinate Cycle which will last about ten minutes. The FoodSaver® Quick Marinating Canister (not included) is the perfect FoodSaver® accessory for marinating foods.

During the Marinate Cycle, the vacuum pump will “hold” the vacuum for several minutes then release the vacuum, allowing the food to “rest” for 30 seconds. This process then repeats. This “pulsing” action of “vacuuming and resting” will allow for quicker more flavorful marinating.

IMPORTANT NOTE: During the Quick Marinate Cycle, make sure knob on lid of the Quick Marinating Canister is set to OPEN. **Do not set knob to Vacuum during the Marinate Cycle.**

1. Prepare enough of your favorite marinade to fully cover food inside a marinating canister.

Always leave at least one inch (2.54 centimeters) of space between contents and top of rim.

2. Make sure rubber gasket underneath lid as well as rim of marinating canister is free from food materials.
3. Pull out the Retractable Handheld Sealer from your FoodSaver® appliance. Remove clear bottom portion of handheld from top handle (Fig. 1).
4. Insert the end into the port on the canister. Make sure knob on accessory lid is set to OPEN (Fig. 2).
5. Make sure lid is firmly attached to marinator base.
6. Press Marinate button **2** on the control panel (Fig. 3).
7. Your FoodSaver® Vacuum Sealing System will now begin the Quick Marinate Cycle. The Marinate Indicator Light will flash to indicate the marinating process has begun.
8. During the initial vacuum cycle the Marinate Mode Indicator will illuminate. While Marinating, the Vacuum Progress Display will blink during the Vacuum Hold or Rest Cycle.
9. To preserve food safely, after completing the marinating cycle, the appliance will signal with short beeps to indicate your Quick Marinate Cycle is completed. Press any button to silence the signal. You may now cook or refrigerate your marinated food.
10. To use the Quick Marinating Canister for extended vacuum storage (beyond the short Marinate Cycle): Rotate knob to Vacuum/Canister position, connect the Accessory hose (as above) and select the Accessory Mode **1** from the control panel. When motor turns off, rotate knob clockwise to the “Closed” position, then gently twist and remove Retractable Handheld Sealer from accessory.

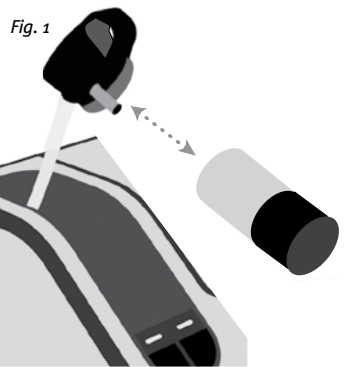

Fig. 2

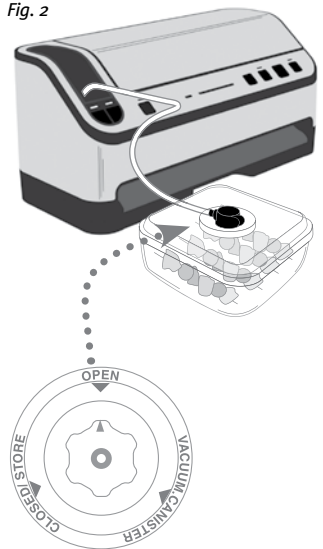
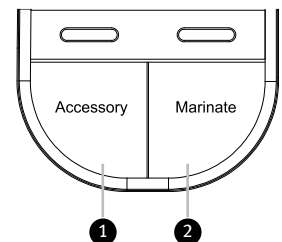

Fig. 3



Care and Cleaning

To Clean Appliance:

Press Power Button **10** and remove Power Cord from electrical outlet. Do not immerse in liquid.

Slide out Drip Tray Drawer (**P**). Remove Drip Tray for cleaning by pulling up on the two side tabs. Check Lower Gasket (**O**) around Drip Tray (**P**) to make sure it is free from food materials.

Do not attempt to remove gaskets.

Antibacterial Drip Tray:

Empty Drip Tray after each use. Wash in warm soapy water or place in top rack of dishwasher. The Adjustable Food Sensors in the Drip Tray (**P**) will not function correctly if liquid is allowed to remain in Drip Tray.

This appliance has a Tray Full indicator **4**. When excess liquid fills the Drip Tray, the unit will turn off and the Tray Full Indicator light will activate. To resume normal operation, Slide out Drip Tray Drawer. Remove Drip Tray for cleaning by pulling up on the two side tabs. When replacing drip tray, set the right end of the drip tray into place, then firmly snap both sides down. Appliance can be used without Drip Tray, however the Adjustable Food Sensor setting **8** will not function without the Drip Tray.

Retractable Handheld Sealer Reservoir:

Empty Reservoir after each use. Wash in warm soapy water. Air dry before replacing.

IMPORTANT:

To remove Reservoir from Retractable Handheld Sealer: While holding top portion by hose pull clear Reservoir down and off.

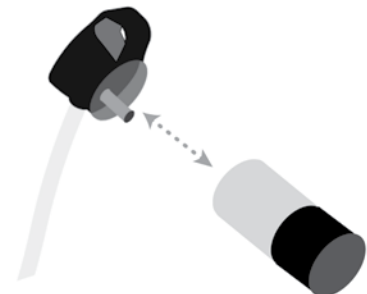
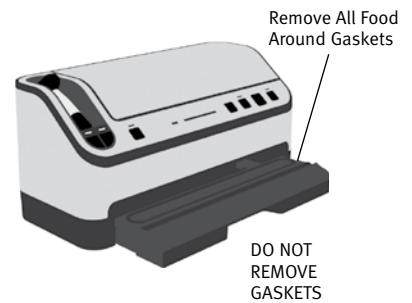
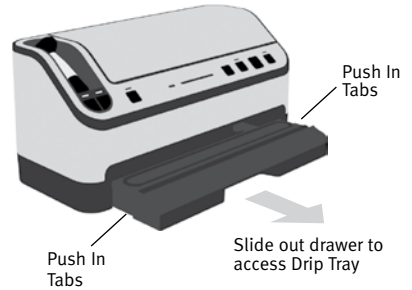

Guidelines for Vacuum Packaging

Vacuum Packaging and Food Safety

The vacuum packaging process extends the life of foods by removing most of the air from the sealed container, thereby reducing oxidation, which affects nutritional value, flavor and overall quality. Removing air can also inhibit growth of microorganisms, which can cause problems under certain conditions:

Mold – Easily identified by its fuzzy characteristic. Mold cannot grow in a low oxygen environment, therefore vacuum packaging can slow the growth of mold.

Yeast – Results in fermentation, which can be identified by smell and taste. Yeast needs water, sugar and a moderate temperature to grow. It can also survive with or without air. Slowing the growth of yeast requires refrigeration, while freezing stops it completely.

Bacteria – Results in an unpleasant odor, discoloration and/or soft or slimy texture. Under the right conditions, anaerobic bacteria such as *Clostridium botulinum* (the organism that causes Botulism) can grow without air and sometimes cannot be detected by smell or taste. Although it is extremely rare, it can be very dangerous.

To preserve foods safely, it is critical that you maintain low temperatures. You can significantly reduce the growth of microorganisms at temperatures of 40°F (4°C) or below. Freezing at 0°F (-17°C) does not kill microorganisms, but stops them from growing. For long-term storage, always freeze perishable foods that have been vacuum packaged, and keep refrigerated after thawing.

It is important to note that vacuum packaging is NOT a substitute for canning and it cannot reverse the deterioration of foods. It can only slow down the changes in quality. It is difficult to predict how long foods will retain their top-quality flavor, appearance or texture because it depends on age and condition of the food on the day it was vacuumed packaged.

IMPORTANT: Vacuum packaging is NOT a substitute for refrigeration or freezing. Any perishable foods that require refrigeration must still be refrigerated or frozen after vacuum packaging.

Food Preparation and Reheating Tips

Thawing and Reheating Vacuum Packaged Foods

Always thaw foods in either refrigerator or microwave — do not thaw perishable foods at room temperature.

To reheat foods in a microwave in a FoodSaver® Bag, always cut corner of the bag before placing it on a microwave-safe dish. However, to avoid hot spots, do not reheat bone-in meat or greasy foods in microwave within a FoodSaver® Bag. You can also reheat foods in FoodSaver® Bags by placing them in water at a low simmer below 170°F (75°C).

Preparation Guidelines for Meat and Fish:

For best results, pre-freeze meat and fish for 1-2 hours before vacuum packaging in a FoodSaver® Bag. This helps retain the juice and shape, and guarantees a better seal.

If it's not possible to pre-freeze, place a folded paper towel between meat or fish and top of bag, but below seal area. Leave paper towel in bag to absorb excess moisture and juices during vacuum packaging process.

Note: Beef may appear darker after vacuum packaging due to the removal of oxygen. This is not an indication of spoilage.

Preparation Guidelines for Hard Cheeses:

To keep cheese fresh, vacuum package it after each use. Make your FoodSaver® Bag extra long, allowing one inch of bag material for each time you plan to open and reseal in addition to the 4-inch room you normally leave between contents and seal. Simply cut sealed edge and remove cheese. When you're ready to repack the cheese, just drop it in bag and reseal.

IMPORTANT: Due to the risk of anaerobic bacteria, Soft cheeses should never be vacuum packaged.

Preparation Guidelines for Vegetables:

Vegetables need to be blanched before vacuum packaging. This process stops the enzyme action that could lead to loss of flavor, color and texture.

To blanch vegetables, place them in boiling water or in the microwave until they are cooked, but still crisp. Blanching times range from 1 to 2 minutes for leafy greens and peas; 3 to 4 minutes for snap peas, sliced zucchini or broccoli; 5 minutes for carrots; and 7 to 11 minutes for corn on the cob. After blanching, immerse vegetables in cold water to stop the cooking process. Finally, dry vegetables on a towel before vacuum packaging.

Note: All vegetables (including broccoli, brussels sprouts, cabbage, cauliflower, kale, turnips) naturally emit gases during storage. Therefore, after blanching, they must be stored in freezer only. When freezing vegetables, it is best to pre-freeze them for 1-2 hours or until solidly frozen.

To freeze vegetables in individual servings, first place on a baking sheet and spread them out so they are not touching. This prevents them from freezing together in a block. Once they are frozen, remove from baking sheet and vacuum package vegetables in a FoodSaver® Bag. After they have been vacuum packaged, return them to the freezer.

IMPORTANT: Due to the risk of anaerobic bacteria, Fresh mushrooms, onions, & garlic should never be vacuum packaged.

Preparation Guidelines for Leafy Vegetables:

For best results, use a canister to store leafy vegetables. First wash the vegetables, and then dry with a towel or salad spinner. After they are dried, put them in a canister and vacuum package.

Store in refrigerator.

Preparation Guidelines for Fruits:

When freezing soft fruits or berries, it is best to pre-freeze them for 1-2 hours or until solidly frozen. To freeze fruit in individual servings, first place on a baking sheet and spread them out so they are not touching. This prevents them from freezing together in a block. Once they are frozen, remove from baking sheet and vacuum package fruit in a FoodSaver® Bag. After they have been vacuum packaged, return them to the freezer.

You can vacuum package portions for baking, or in your favorite combinations for easy fruit salad all year round. If storing in the refrigerator, we recommend using a FoodSaver® Canister.

Preparation Guidelines for Baked Goods:

To vacuum package soft or airy baked goods, we recommend using a FoodSaver® Canister so they will hold their shape. If using a bag, pre-freeze for 1-2 hours or until solidly frozen. To save time, make cookie dough, pie shells, whole pies, or mix dry ingredients in advance and vacuum package for later use.

Preparation Guidelines for Coffee and Powdery Foods:

To prevent food particles from being drawn into vacuum pump, place a coffee filter or paper towel at top of bag or canister before vacuum packaging. You can also place the food in its original bag inside a FoodSaver® Bag, or use a FoodSaver® Universal Lid with the original container to vacuum package.

Preparation Guidelines for Liquids:

Before you vacuum package liquids such as soup stock, pre-freeze in a casserole dish, loaf pan or ice cube tray until solid. Remove frozen liquid from pan and vacuum package in a FoodSaver® Bag. You can stack these “frozen bricks” in your freezer. When you’re ready to use, just cut corner of bag and place

in a dish in microwave or drop into water at a low simmer, below 170°F (75°C).

To vacuum package non-carbonated bottled liquids, you can use a FoodSaver® Bottle Stopper with the original container. Remember to leave at least one inch of room between contents and bottom of Bottle Stopper. You can re-seal bottles after each use.

Preparation Guidelines for Make-ahead Meals, Leftovers and Sandwiches:

Efficiently store your make-ahead meals, leftovers and sandwiches in the stackable, lightweight FoodSaver® containers. They are microwaveable and top rack dishwasher safe. The lightweight containers will be ready to head off to the office or school when you are!

Preparation Guidelines for Snack Foods:

Your snack foods will maintain their freshness longer when you vacuum package them. For best results, use a FoodSaver® Canister for crushable items like crackers.

Vacuum Packaging Non-Food Items

The FoodSaver® vacuum packaging system also protects non-food items from oxidation, corrosion and moisture. Simply follow the directions to vacuum package items using FoodSaver® Bags, Canisters (not included) and Accessories.

To vacuum package silver, wrap fork tines in soft cushioning material, such as a paper towel, to avoid puncturing bag. Your FoodSaver® Bags are ideal for outdoor excursions. For camping and hiking, keep your matches, maps and food dry and compact. To have fresh water for drinking, simply fill a FoodSaver® Bag with ice, seal it and when needed, let the ice pack melt. If you’re going sailing or boating, vacuum package your food, film and a dry change of clothes. Just remember to bring scissors or a knife to open the bag.

To keep emergency kits safe and dry, vacuum package flares, batteries, flashlights, matches, candles and other necessities. Your emergency items will stay dry and organized in your home, car or boat

Storage Guide

Meat, Cheese, Vegetables, Fruits

Foods	Where to Store	Recommended FoodSaver® Bag/Accessory	Storage Life with FoodSaver® System	Normal Storage Life
Meat				
Beef, Pork, Lamb	Freezer	FoodSaver® Bag	2-3 years	6 months
Ground Meat	Freezer	FoodSaver® Bag	1 year	4 months
Poultry	Freezer	FoodSaver® Bag	2-3 years	6 months
Fish	Freezer	FoodSaver® Bag	2 years	6 months
Hard Cheeses (Do not vacuum package soft cheese)				
Cheddar, Swiss	Refrigerator	FoodSaver® Bag, Canister	4-8 months	1-2 weeks
Parmesan	Refrigerator	FoodSaver® Bag, Canister	4-8 months	1-2 weeks
Vegetables (Do not vacuum package fresh mushrooms, onions & garlic)				
Asparagus	Freezer	FoodSaver® Bag	2-3 years	8 months
Broccoli, Cauliflower	Freezer	FoodSaver® Bag	2-3 years	8 months
Cabbage, Brussels Sprouts	Freezer	FoodSaver® Bag	2-3 years	8 months
Corn (cob or kernel)	Freezer	FoodSaver® Bag	2-3 years	8 months
Green Beans	Freezer	FoodSaver® Bag	2-3 years	8 months
Lettuce, Spinach	Refrigerator	FoodSaver® Canister	2 weeks	3-6 days
Snow Peas, Snap Peas	Freezer	FoodSaver® Bag	2-3 years	8 months
Fruits				
Apricots, Plums	Freezer	FoodSaver® Bag	1-3 years	6-12 months
Peaches, Nectarines	Freezer	FoodSaver® Bag	1-3 years	6-12 months
Softer Berries				
Raspberries, Blackberries	Refrigerator	FoodSaver® Canister	1 week	1-3 days
Strawberries	Refrigerator	FoodSaver® Canister	1 week	1-3 days
Harder Berries				
Blueberries	Refrigerator	FoodSaver® Canister	2 weeks	3-6 days
Cranberries	Refrigerator	FoodSaver® Canister	2 weeks	3-6 days
Huckleberries	Refrigerator	FoodSaver® Canister	2 weeks	3-6 days

Storage Guide

Baked Goods, Coffee, Snacks and Liquids

Foods	Where to Store	Recommended FoodSaver® Bag/Accessory	Storage Life with FoodSaver® System	Normal Storage Life
Baked Goods				
Bagels, Bread, Pastries	Freezer	FoodSaver® Bag	1-3 years	6-12 months
Nuts				
Almonds, Peanuts	Pantry	FoodSaver® Bag, Canister	2 years	6 months
Sunflower Seeds	Pantry	FoodSaver® Bag, Canister	2 years	6 months
Coffee				
Coffee Beans	Freezer	FoodSaver® Bag	2-3 years	6 months
Coffee Beans	Pantry	FoodSaver® Bag, Canister	1 year	3 months
Ground Coffee	Freezer	FoodSaver® Bag	2 years	6 months
Ground Coffee	Pantry	FoodSaver® Bag, Canister	5-6 months	1 month
Prepared Liquids				
Sauces, Soups, Stews	Freezer	FoodSaver® Bag	1-2 years	3-6 months
Bottled Liquids				
Oils	Pantry	FoodSaver® Bottle Stopper	1-1 ½ years	5-6 months
Dry Foods				
Beans, Grains	Pantry	FoodSaver® Bag, Canister	1-2 years	6 months
Pasta, Rice	Pantry	FoodSaver® Bag, Canister	1-2 years	6 months
Powdery Foods				
Dry Milk	Pantry	FoodSaver® Bag, Canister	1-2 years	6 months
Dried Coconut	Pantry	FoodSaver® Bag, Canister	1-2 years	6 months
Flour	Pantry	FoodSaver® Bag, Canister	1-2 years	6 months
Sugar, Brown Sugar	Pantry	FoodSaver® Bag, Canister	1-2 years	6 months
Snack Foods				
Chips	Pantry	FoodSaver® Canister	3-6 weeks	1-2 weeks
Cookies, Crackers	Pantry	FoodSaver® Canister	3-6 weeks	1-2 weeks

Trouble-Shooting

Problem	Solution
Red Seal LED Flashing	<ul style="list-style-type: none"> • Bag not inserted properly. Remove bag, wait for red light to stop flashing and re-insert bag. • Wait 20 seconds between seals. • Unit overheated. Wait several minutes for unit to cool down.
Vacuum Pump is running, but bag is not evacuating	<ul style="list-style-type: none"> • If making a bag from a roll, make sure one end of bag is sealed. (See “How to Make a Bag from a FoodSaver® Vacuum Sealing Roll” on page 8.) • Slide out drip tray drawer and make sure there are no foreign objects, dirt or debris on the bottom gasket. (See “Care and Cleaning” on page 13.)
Bag is not sealing properly	<ul style="list-style-type: none"> • Too much liquid in bag; freeze before vacuuming. • To prevent wrinkles in the seal, gently stretch bag flat while inserting bag into vacuum channel and continue to hold bag until vacuum pump starts. • Unit overheated. Wait several minutes for unit to cool down.
No lights on the control panel	<ul style="list-style-type: none"> • Make sure unit is plugged in. • Make sure wall outlet is functional. • Press on/off button.
Nothing happens when bag is inserted	<ul style="list-style-type: none"> • Make sure unit has power (see above tip). • Tray Full; empty drip tray. Clean Drip Tray and place back into appliance. (See “Care and Cleaning” page 13.) • Too much food in bag. Avoid overfilling. Allow 4 inches (10.16cm) of space between contents and top of bag. • Bag not inserted correctly. Insert bag CURL DOWN. Gently stretch bag flat while inserting. Hold bag until Vacuum Pump starts.
Tray Full LED Flashing	<ul style="list-style-type: none"> • Drip Tray has liquid or Drip Tray may be dirty. Empty liquid, clean Drip Tray and place back into appliance. (See “Care and Cleaning” on page 13.)
Handheld Sealer not sealing	<ul style="list-style-type: none"> • Ensure zipper is firmly closed. Slide fingers across entire zipper. • Air valve is not on flat surface. Reposition bag so the air valve lies flat on counter with no food under air valve.
Vacuum Nozzle and Air Valve are not making secure contact	<ul style="list-style-type: none"> • Ensure Vacuum Nozzle is centered over the gray circle and placed flat on air valve. Apply moderate pressure
Air was removed from the bag but now air has re-entered.	<ul style="list-style-type: none"> • Examine zipper and valve of bag. Food debris in zipper or valve may cause leakage and allow air to enter. • Sometimes moisture or food material along seal edges of the zipper or beneath the valve prevents bag from sealing properly. Wipe the inside of bag around zipper and beneath valve and attempt to reseal. • If you are vacuum packaging sharp food items, bag may have been punctured. Use a new bag if there is a hole. Cover sharp food items with a soft cushioning material, such as a paper towel, and reseal.
The FoodSaver® Container will not vacuum	<ul style="list-style-type: none"> • Make sure rubber gasket on inside of lid is free from food materials. • Examine rim of container for cracks or scratches. Any gaps can prevent containers from vacuuming properly.
If you need further assistance:	<ul style="list-style-type: none"> • Call Consumer Services at 1-877-777-8042. • For additional tips and answers to frequently asked questions, go to www.foodsaver.com/Support.aspx

Recipes for your FoodSaver® Appliance

For additional delicious recipes using the FoodSaver® system to prepare foods in advance, check our website, www.foodsaver.com.

ORANGE-ALMOND POUND CAKE

Ingredients:

3 cups all-purpose flour, sifted	1/2 teaspoon almond extract
1 cup (2 sticks) butter, softened	1 cup milk
1/2 teaspoon baking powder	1 teaspoon vanilla
2 cups sugar	1 tablespoon orange juice
1/2 teaspoon baking soda	Starfruit slices, strawberry slices and orange peel curls (optional)
2 eggs	
1/2 teaspoon salt	

Cooking Directions:

Preheat oven to 350°F. Grease and flour two 9x5-inch loaf pans.

Whisk flour, baking powder, baking soda and salt in medium bowl.

Combine milk and orange juice in small bowl.

Beat butter and sugar in large bowl with electric mixer at medium speed until light and fluffy. Add eggs, one at a time, beating well after each addition. Beat in almond extract and vanilla. Add flour mixture alternately with milk mixture, beating well after each addition. Pour into prepared pans.

Bake 35 minutes or until toothpick inserted into centers comes out clean. Cool in pans 10 minutes. Remove to wire racks; cool completely. Garnish with starfruit, strawberries and orange peel.

TORTILLA SOUP

Makes 4 servings

Ingredients:

2 teaspoons vegetable oil	Tortilla chips, broken into pieces
1 cup shredded cooked chicken	2 cans (about 14 ounces each) chicken broth
1/2 cup chopped onion	1 small avocado, diced
2 teaspoons lime juice	1 can (about 14 ounces) diced tomatoes
1 clove garlic, minced	2 tablespoons fresh cilantro

Cooking Directions:

Heat oil in large saucepan over medium heat. Add onion and garlic; cook and stir until onion is tender. Add broth and tomatoes; bring to a boil. Reduce heat to low; cover and simmer 15 minutes.

Add chicken and lime juice; simmer 5 minutes. Top soup with tortilla chips, avocado and cilantro.

GARLIC PORK WITH ROASTED RED POTATOES

Ingredients:

Nonstick cooking spray	1/2 teaspoon salt
6 new potatoes, scrubbed and quartered	1 pound pork tenderloin
1/2 teaspoon paprika	1/2 teaspoon black pepper
1 teaspoon dried oregano	1 tablespoon olive oil
1/2 teaspoon garlic powder	

Cooking Directions:

Preheat oven to 425°F. Coat 13x9-inch baking pan with cooking spray.

Combine paprika and garlic powder in small bowl; sprinkle evenly over pork.

Coat large skillet with cooking spray; heat over medium-high heat.

Brown pork 3 minutes per side. Transfer to baking pan.

Add oil, potatoes and oregano to skillet; toss to coat. Arrange potatoes around pork.

Sprinkle with salt and pepper. Bake 22 minutes or until barely pink in center.

Transfer pork to carving board; tent with foil and let stand 5 minutes.

Stir potatoes; tent with foil and let stand 5 minutes.

Slice pork and serve with potatoes.

GRILLED CHINESE SALMON

Makes 4 servings

Ingredients:

3 tablespoons soy sauce
4 salmon fillet pieces or steaks (about 1 pound)
2 tablespoons dry sherry
2 tablespoons finely chopped fresh cilantro
2 cloves garlic, minced

Cooking Directions:

Combine soy sauce, sherry and garlic in FoodSaver® Quick Marinator. Add salmon; turn to coat.

Place lid on container. Turn knob to Open/Marinate and attach Accessory Hose. Press Marinate Button.

When the 12-minute cycle is complete, remove hose and open lid.

Oil grid or broiler pan rack. Prepare grill for direct cooking over medium heat or preheat broiler.

Drain salmon, reserving marinade. Grill or broil, skin side down, 10 minutes or until salmon begins to flake when tested with fork. Baste with reserved marinade after 5 minutes; discard any remaining marinade.

Sprinkle with cilantro.

FLANK STEAK WITH ITALIAN SALSA

Makes 6 servings

Ingredients:

2 tablespoons olive oil	1/3 cup chopped pitted kalamata olives
3/4 teaspoon black pepper, divided	1 tablespoon garlic, minced
2 teaspoons balsamic vinegar	2 tablespoons chopped fresh basil
1 cup diced plum tomatoes	3/4 teaspoon salt, divided
1 flank steak (1 1/2 pounds)	

Cooking Directions:

Whisk oil and vinegar in medium glass bowl. Place steak in FoodSaver® Quick Marinator; spread with garlic. Sprinkle 1/2 teaspoon salt and 1/2 teaspoon pepper over steak. Spoon 2 tablespoons vinegar mixture over steak. Place lid on container. Turn knob to Open/Marinate and attach Accessory Hose. Press Marinate Button. When the 12-minute cycle is complete, remove hose and open lid.

Meanwhile, add tomatoes, olives, basil, remaining 1/4 teaspoon salt and 1/4 teaspoon pepper to bowl; mix well. Set aside.

Prepare grill for direct cooking over medium-high heat. Remove steak from marinade; discard marinade. Grill steak 5 minutes per side for medium-rare doneness.

Transfer steak to carving board. Tent with foil; let stand 5 minutes. Cut steak diagonally across grain into thin slices. Serve with tomato salsa mixture.

CHOCOLATE PINWHEELS

Makes 3 1/2 dozen cookies

Ingredients:

2 cups (4 sticks) unsalted butter, softened	1/4 cup packed light brown sugar
4 cups all-purpose flour	1 tablespoon unsweetened cocoa
1 cup powdered sugar	1/2 teaspoon salt
1/2 cup semisweet chocolate chips, melted	

Cooking Directions:

Beat butter, powdered sugar, brown sugar and salt in large bowl with electric mixer at medium speed 2 minutes or until light and fluffy. Gradually add flour, beating well after each addition. Reserve one half of dough. Add melted chocolate and cocoa to remaining dough; beat until well blended.

Divide the chocolate and plain doughs each into 4 pieces; shape each piece into ball. Roll one ball plain dough into 12x6-inch rectangle on floured surface; transfer to sheet of parchment paper or plastic wrap. Roll one ball chocolate dough into 12x6-inch rectangle on floured surface; place on top of plain dough rectangle. Tightly roll up jelly-roll style, starting at the wide end, to form a 12-inch log. If dough crumbles or breaks, press back together and continue to roll. Wrap in plastic wrap; refrigerate 1 hour. Repeat with remaining dough.

Preheat oven to 300°F. Cut each log into 20 slices; place on ungreased cookie sheets. Bake 13 minutes or until set. Cool on cookie sheets 5 minutes. Remove to wire racks; cool completely.

SPINACH FETA TRIANGLES

Makes 5 dozen appetizers

Ingredients:

1/4 cup olive oil	3 packages (10 ounces each) frozen chopped spinach, thawed and well drained
1/2 cup minced fresh parsley	1 package (16 ounces) frozen phyllo dough, thawed
1/2 cup chopped onion	16 ounces feta cheese, drained and crumbled
2 tablespoons chopped fresh oregano	1 cup cup (2 sticks) butter, melted
2 eggs	
Salt and black pepper	

Cooking Directions:

Heat oil in small skillet over medium-high heat. Add onion; cook and stir until golden brown. Let stand 10 minutes.

Beat eggs in large bowl. Stir in onion, spinach, cheese, parsley and oregano. Season with salt and pepper.

Unroll phyllo onto large sheet of waxed paper. Cut crosswise into thirds. Cover with plastic wrap and damp, clean kitchen towel.*

Brush one piece of phyllo with melted butter. Fold in half lengthwise. Brush with butter again. Place rounded teaspoonful of filling at end of phyllo; fold over one corner to make triangle. Continue folding end over end, as you would a flag, keeping edges straight. Brush with butter. Repeat with remaining ingredients.

Preheat oven to 375°F. Place triangles in single layer, seam side down, on ungreased baking sheet. Bake 20 minutes or until lightly browned. Serve warm.

5 Year Limited Warranty

Sunbeam Products, Inc. doing business as Jarden Consumer Solutions, or if in Canada, Sunbeam Corporation (Canada) Limited doing business as Jarden Consumer Solutions (collectively “JCS”) warrants that from the date of purchase, this product will be free from defects in material and workmanship provided this product is used with FoodSaver® bags and/or rolls. This Limited Five-Year Warranty shall be effective from the date of the original purchase date and shall expire five (5) years after the original purchase date (“Limited Warranty Period”). JCS, at its option, will repair or replace this product or any component of the product found to be defective during the Limited Warranty Period, provided the defect is not caused by the use of any non-FoodSaver® branded bags and/or rolls. A replacement will be made with a new or remanufactured product or component. If the product is no longer available a replacement may be made with a similar product of equal or greater value. This is your exclusive Limited Warranty. Do NOT attempt to repair or adjust any electrical or mechanical functions on this product. Doing so will void this Limited Warranty. This Limited Warranty is valid for the original retail purchaser from the date of initial retail purchase and is not transferable. Keep the original sales receipt. Proof of purchase is required to obtain warranty performance. JCS dealers, service centers, or retail stores selling JCS products do not have the right to alter, modify or any way change the terms and conditions of this Limited Warranty. This Limited Warranty does not cover normal wear of parts or damage resulting from any of the following: negligent use or misuse of the product, use on improper voltage or current, use contrary to the operating instructions, disassembly, repair or alteration by anyone other than JCS or an authorized JCS service center, or use of this product with non-FoodSaver® branded bags and/or rolls. Further, this Limited Warranty does not cover: Acts of God, such as fire, flood, hurricanes and tornadoes.

What are the limits on JCS' Liability?

Damage to a product caused by use of non-FoodSaver® branded bags and/or rolls, accident, misuse, or abuse is not covered by this Limited Warranty. Improper care and cleaning will void this Limited Warranty. JCS shall not be liable for any incidental or consequential damages caused by the breach of any express, implied or statutory warranty or condition. Except to the extent prohibited by applicable law, any implied warranty or condition of merchantability or fitness for a particular purpose is limited in duration to the duration of the above warranty. JCS disclaims all other warranties, conditions or representations, express, implied, statutory or otherwise. JCS shall not be liable for any damages of any kind resulting from the purchase, use or misuse of, or inability to use the product including incidental, special, consequential or similar damages or loss of profits, or for any breach of contract, fundamental or otherwise, or for any claim brought against purchaser by any other party. Some provinces, states or jurisdictions do not allow the exclusion or limitation of incidental or consequential damages or limitations on how long an implied warranty lasts, so the above limitations or exclusion may not apply to you. This warranty gives you specific legal rights, and you may also have other rights that vary from province to province, state to state or jurisdiction to jurisdiction.

How to Obtain Warranty Service

In the U.S.A.

If you have any question regarding this warranty or would like to obtain warranty service, please call 1-877-777-8042 and a convenient service center address will be provided to you.

In Canada

If you have any question regarding this warranty or would like to obtain warranty service, please call 1-877-804-5383 and a convenient service center address will be provided to you.

In the U.S.A., this warranty is offered by Sunbeam Products, Inc. doing business as Jarden Consumer Solutions located in Boca Raton, Florida 33431. In Canada, this warranty is offered by Sunbeam Corporation (Canada) Limited doing business as Jarden Consumer Solutions, located at 20 B Hereford Street, Brampton, Ontario L6Y 0M1. If you have any other problem or claim in connection with this product, please write our Consumer Service Department.

PLEASE DO NOT RETURN THIS PRODUCT TO ANY OF THESE ADDRESSES OR TO THE PLACE OF PURCHASE.



Registering your appliance is quick and easy at www.prodregister.com/foodsaver. If you register on our website, you will have the opportunity to receive special bag and accessory introductory offers. Refer to the registration card inside the box.

For important safety information and helpful tips, please visit us at www.foodsaver.com to get tips on vacuum sealing and order FoodSaver® brand accessories, bags and rolls, or call 1-877-777-8042 (U.S.).

©2013 Sunbeam Products, Inc. doing business as Jarden Consumer Solutions. All rights reserved.
Distributed by Sunbeam Products, Inc. doing business as Jarden Consumer Solutions, Boca Raton, Florida 33431.