

Hazardous Area Telephone

Model EP600

Installation and Operation

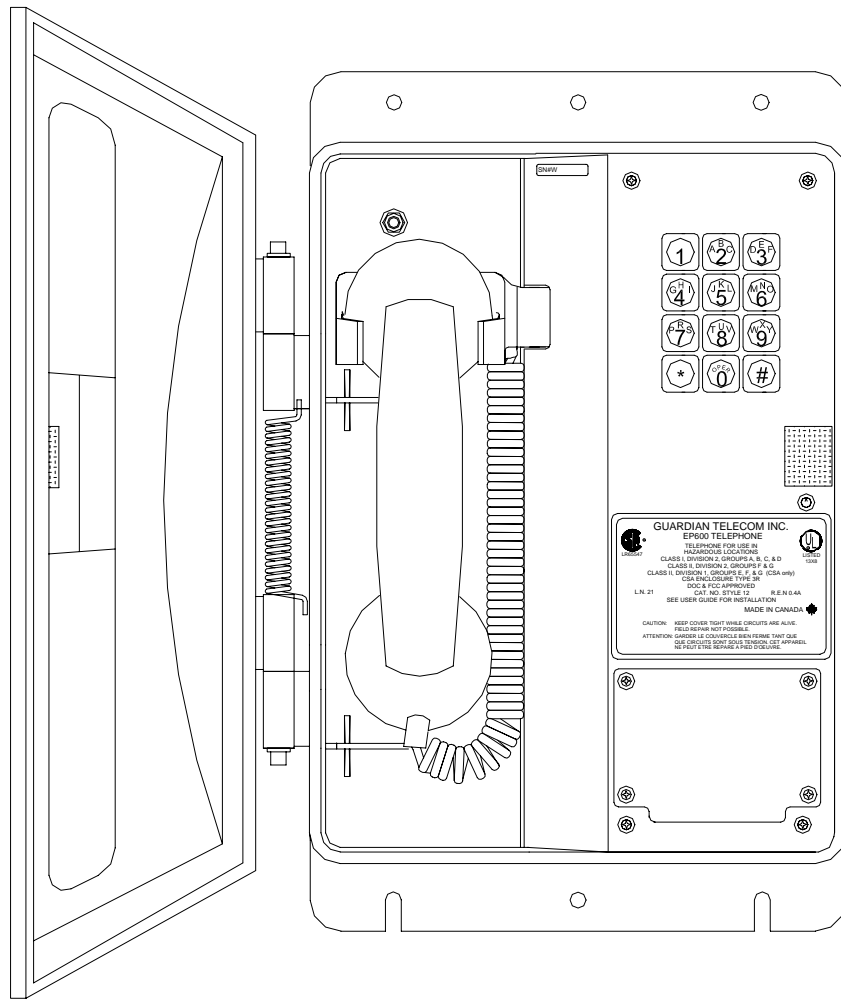

GUARDIAN TELECOM INC.
EP600 TELEPHONE
TELEPHONE FOR USE IN
HAZARDOUS LOCATIONS
CLASS I, DIVISION 2, GROUPS A, B, C, & D
CLASS II, DIVISION 1, GROUPS E, F, & G (CSA only)
CLASS II, DIVISION 1, GROUPS E, F, & G (CSA only)
CISR EXPLORERS TYPE 04
DOC 4 FCC APPROVED
CASE NO. 8752-12 R.E.N. 0-04
SEE USER GUIDE FOR INSTALLATION
MADE IN CANADA

CAUTION: KEEP COVER TIGHT WHILE CIRCUITS ARE ALIVE.
FIELD REPAIR NOT POSSIBLE.
ATTENTION: GARDER LE COUVERCLE BIEN FERMÉ TANT QU'IL
Y A DES CIRCUITS EN TENSION. NE PAS
REPARER SUR LE CHAMP S'IL Y A DES
CIRCUITS EN TENSION.

Table of Contents

| | |
|------------------------------------|----|
| Package Contents | 2 |
| Overview | 3 |
| Features | 3 |
| Installing the EP600 | 5 |
| Maintenance..... | 5 |
| Operation | 6 |
| Setting Tone/Pulse Operation | 6 |
| Engineering Specifications | 7 |
| Warranty..... | 9 |
| Disclaimer | 9 |
| Warning..... | 9 |
| Service Telephone Number..... | 9 |
| Feedback | 9 |
| Guardian Product Return | 10 |

Table of Figures

| | |
|--|---|
| Figure 1 - Overall Dimensions..... | 4 |
| Figure 2 - Installation..... | 4 |
| Figure 3 - Setting Tone/Pulse Operation..... | 6 |

Package Contents

- (1) EP600 Telephone
- (1) Installation & Operation Manual

Overview

Hazardous Area Telephone

The EP600 Telephone is designed to provide safe, reliable communication in Class 1, Division 2, hazardous locations. The unit is housed in a rugged, weather and corrosion resistant enclosure that ensures operation in severe conditions.

Features

Enclosure

- weather tight, rugged Valox & steel
- spring loaded hinged door
- stainless steel mounting bracket

Keypad

- standard 3 x 4 matrix

Magnetic Reed Hook Switch

- no moving parts

Surge Arrestor

- prevents damage to the electronic circuitry in the event of a high voltage spike on the telephone line

Wall Mount

- easily mounted on any sturdy vertical structure

Noise Reducing Microphone

- allows a high level of intelligibility in locations with high background noise

Tone (DTMF) Operation

- factory set to tone (DTMF) dialing
- can be ordered set for pulse dialing or configured in the field

Heavy Duty Handset Cord

- withstands severe use

Hearing-Aid Compatible

- compatible with inductively coupled hearing-aid devices

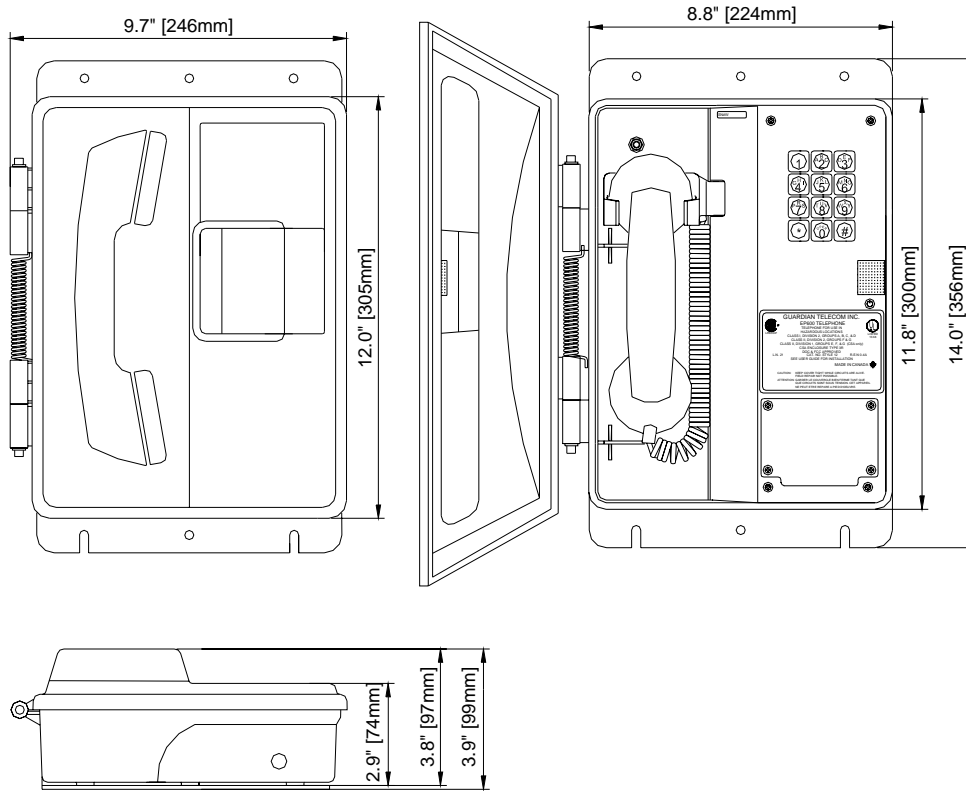

Figure 1 - Overall Dimensions

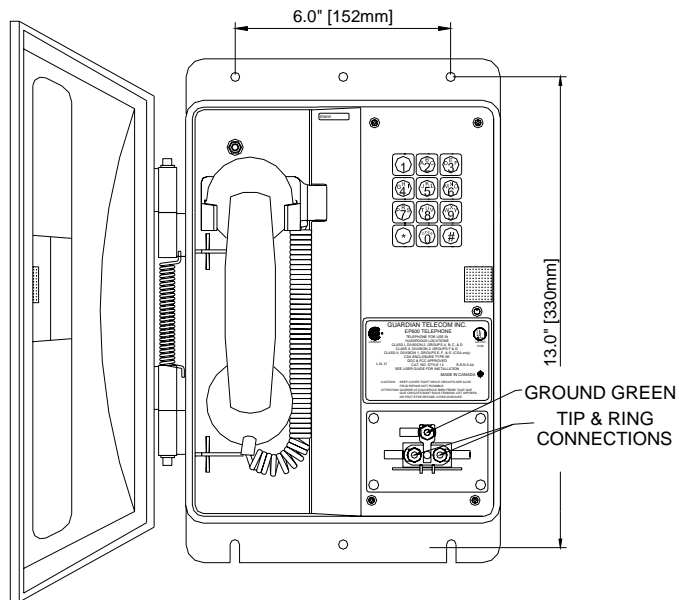

Figure 2 - Installation

Installing the EP600

- **Declassify the hazardous location before proceeding with any installation or electrical wiring.**
- The EP600 is set to tone dialing when shipped. If pulse dialing is required see the section on Setting Tone/Pulse Operation.
- Follow all appropriate electrical codes and use only approved electrical fittings for the installation.
- Choose a wall location that is free of obstructions and permits space for ½” NPT conduit runs.
- Ensure mounting can support 5 lbs (2.3 kgs) and any foreseeable additional load.
- Ensure that none of the electrical connection circuits are live.
- Use the template provided or the stainless steel mounting bracket to locate and drill holes for mounting screws.
- Secure the unit to the wall.
- Open the door and remove the four #8 Philips drive screws on the access plate.
- Connect an approved earth ground to the center post of the surge arrestor.
- Connect the wires from the PABX or CO to the tip and ring connections on the surge arrestor. (The unit is not polarity sensitive.)
- Ensure all connections are tight, then replace the access plate and secure with the four #8 Philips drive screws.
- Apply power to the system.
- Test the unit by calling from another unit on the exchange.

Caution: *Installation or electrical wiring in a hazardous location could result in serious injury to personnel or damage to property.*

See: *Setting Tone/Pulse Operation*

See: *EP600 Drawing, Figure 1 - Overall Dimensions.*

See: *EP600 Drawing, Figure 1 - Overall Dimensions.*

Tip: *Use #8 or M4 screws to secure the unit to the wall.*

See: *Figure 2 - Installation*

Maintenance

- **Declassify the hazardous location before proceeding with any maintenance or repairs.**
- To maintain hazardous area compliance the only field adjustment permitted is to change the tone/pulse setting. All other repairs or alterations must be carried out by Guardian Telecom or an Authorized Service Depot.

See: *Warranty and Guardian Product Return*

Operation

- Once your Model EP600 Telephone has been properly installed and energized, operation is identical to most other single line telephones.

Setting Tone/Pulse Operation

- Ensure that none of the electrical connection circuits are live.
- Loosen the five captive screws in the faceplate and swing the faceplate to the left. If the set is installed on a vertical surface the faceplate will stay open like a book in this position. Take care not to disturb the internal wiring.
- Set the Tone/Pulse jumper for the desired operation. For pulse, set jumper between the center pin and the "P", for tone set it between the center pin and "T".
- Replace the faceplate.
- Check the set visually for loose screws and trapped wires. Check that the handset hangs freely in the cradle and that the handset cord is not trapped by the door.
- Check that the faceplate is snug to its gasket, paying particular attention to the area around the cradle. Check that the door closes flush to the housing.
- Apply power to the system.
- Test the unit by calling to and from another unit on the exchange.

See: Figure 3 - Setting Tone/Pulse Operation

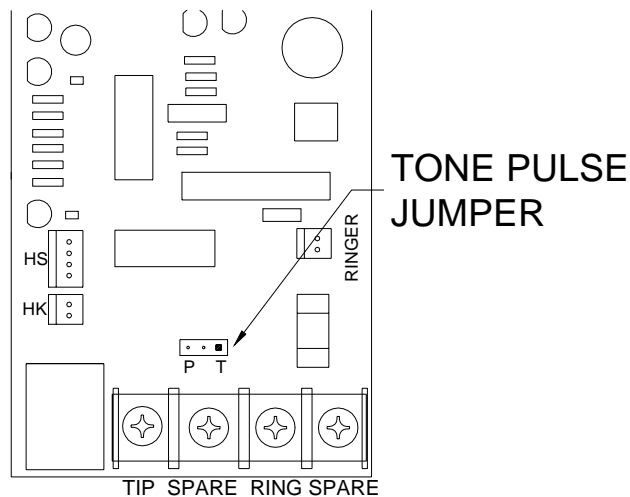

Figure 3 - Setting Tone/Pulse Operation

| Engineering Specifications | |
|--|---|
| <i>Electrical Performance</i> | |
| AUDIBLE RANGE FREQUENCY RESPONSE | 300 - 3400 Hz |
| DIALING METHOD | DTMF TONE or 40/60 PULSE AT 10 PPS |
| TRANSMIT OBJECTIVE LOUDNESS RATING (TOLR) | -40 +/- 3 dB |
| RECEIVE OBJECTIVE LOUDNESS RATING (ROLR) | 47 +/- 3 dB |
| SIDE TONE OBJECTIVE LOUDNESS RATING (SOLR) | 10 +/- 4 dB |
| RINGER OUTPUT | 75 dB Maximum |
| FCC RINGER EQUIVALENCE NUMBER (REN) | 0.7 B (mechanical bell) |
| SET IMPEDANCE | 600 OHMS NOMINAL |
| MAXIMUM LOOP | 15 Kft (4.6 Km) |
| <i>Electrical Requirements</i> | |
| RINGER SENSITIVITY | 40 - 100 V, 16 - 25 Hz |
| LINE VOLTAGE | 24 - 56 VDC |
| LOOP CURRENT | 20 - 120 MA |
| CONNECTION METHOD | SURGE ARRESTOR |
| <i>Environmental</i> | |
| WEATHER AND CORROSION RESISTANT | ENCLOSURE 3R |
| TEMPERATURE | -40° TO +60° C (-40° TO +140° F) |
| HUMIDITY | 0 TO 95% RH |
| DUST RESISTANT | CLASS II HAZARDOUS LOCATIONS |
| <i>Mechanical</i> | |
| HOOK SWITCH (CRADLE SWITCH) LIFE | >1 000 000 OPERATIONS |
| BODY CONSTRUCTION | GE VALOX 357 ^R ENGINEERING POLYMER |
| FACEPLATE | STAINLESS STEEL |
| DIMENSIONS (H x W x D) | 14 x 9.7 x 3.9 INCHES (356 x 246 x 99 MM) |
| NET WEIGHT | 5 LBS (2.3 KG) |
| HANDSET MATERIAL | HIGH IMPACT ABS |
| MICROPHONE | NOISE REDUCING ELECTRET |
| OPTIONAL MICROPHONE | NOISE CANCELING DYNAMIC |
| RECEIVER | HEARING AID COMPATIBLE |
| STANDARD MOUNTING | VERTICAL WALL |
| CONNECTION FITTINGS | 1/2" NPT CONDUIT HUB |
| HARDWARE MATERIAL | STAINLESS STEEL |

| Compliance | |
|--------------------------------------|--|
| CANADIAN STANDARDS ASSOCIATION (CSA) | REFERENCE NUMBER: LR65547-23 |
| STYLE 12 | CLASS I, DIVISION 2, GROUPS A, B, C AND D CLASS I, ZONE 2, GROUP IIC CLASS II, DIVISION 1 & 2, GROUPS E, F AND G |
| STYLE 21 | CLASS II, DIVISION 1, GROUPS E, F AND G |
| STYLE 22 | CLASS II, DIVISION 2, GROUP G |
| UNDERWRITERS LABORATORIES (UL) | LISTED 13X8 & E117495 |
| STYLE 12 | CLASS I, DIVISION 2, GROUPS A, B, C AND D CLASS II, DIVISION 2, GROUPS F AND G |
| STYLE 22 | CLASS II, DIVISION 2, GROUPS F & G |
| CONFORMITÉ EUROPÉENNE (CE) | |
| STYLE 12 | EMC DIRECTIVE 89/336/EEC LOW-VOLTAGE DIRECTIVE 73/23/EEC ATEX DIRECTIVE 94/9/EC |
| ENCLOSURE | CSA 3R |

GUARDIAN TELECOM INC.

LR65547

EP600 TELEPHONE

TELEPHONE FOR USE IN
HAZARDOUS LOCATIONS

LISTED 13X8

CLASS I, DIVISION 2
GROUPS A, B, C, & D
CLASS 1 ZONE 2 GROUP IIC
CLASS II, DIVISION 1 & 2
GROUPS E, F, & G

CLASS I, DIVISION 2
GROUPS A, B, C, & D
CLASS 1 ZONE 2 GROUP IIC
CLASS II, DIVISION 2
GROUPS F & G

CSA ENCLOSURE TYPE 3R
DOC & FCC APPROVED
CAT. NO. STYLE 12

R.E.N 0.4A L.N. 21

SEE USER GUIDE FOR INSTALLATION

MADE IN  CANADA

CAUTION: KEEP COVER TIGHT WHILE CIRCUITS ARE LIVE.
FIELD REPAIR NOT POSSIBLE.

ATTENTION: GARDER LE COUVERCLE BIEN FERME TANT QUE
LES CIRCUITS SONT SOUS TENSION. CET APPAREIL
NE PEUT ETRE REPARÉ A PIED D'OEUVRE.

Figure 4 - I.D. and Compliance, (Style 12 only)

Warranty

Guardian Telecom warrants your product to be free of defects in material and workmanship for a period of one year. Guardian Telecom will repair or replace any defective unit that is under warranty

This warranty is null and void if any non-authorized modifications have been made to this product, or if it has been subjected to misuse, neglect, or accident. This warranty covers bench repairs only; such repairs must be made at Guardian Telecom or an authorized service depot. Guardian Telecom is not responsible for costs incurred for on-site service calls, freight, or brokerage.

A return authorization must be obtained prior to warranty claims or repairs.

Disclaimer

The products covered by this manual are designed for use in Industrial Environments and/or Hazardous Locations. Due to the range of possible applications for these instruments the manufacturer will not be responsible for damages or losses of any kind suffered as a result of the use of this product, including consequential damages.

Warning

For the purposes of installing the product and replacing fuses this device may be opened and reassembled by qualified personnel, following the instructions in the product manual. In the cases of explosion proof and hazardous area devices it is imperative that mating surfaces be clean and undamaged prior to reassembly and that fasteners be made up to the specified torque.

High voltages may be present in this device when connected to telephone wiring

Service Telephone Number

1-800-363-8010

Guardian Telecom provides a customer service telephone number which is toll-free within North America. If you need assistance when installing or operating this product, please call the toll-free telephone number between regular business hours (8:00AM-5:00PM), Mountain Standard Time. If you are calling outside of regular business hours, please leave a detailed message, and a member of Guardian Telecom's Service Department will return your call as soon as possible. If your product requires service, Guardian personnel will supply you with an RMA (return materials authorization) number over the telephone or through our web site product return page. This number must be included with your return address and the name of the person to contact.

**Guardian Telecom Inc.
7552 - 10th Street N.E.
Calgary, Alberta, Canada T2E 8W1
Toll-free 1-800-363-8010
Ph. (403) 258-3100
Fax. (403) 253-4967
www.guardiantelecom.com**

Feedback

Guardian Telecom continually strives to make reliable, durable, and easy to use products. If you, as an installer or user of our equipment, have any suggestions for improvements to this or any of our products or documents, including this manual, we would appreciate hearing from you.

| Guardian Product Return |
|---|
| <p>Guardian products have been quality tested and are in full working order when shipped from the factory, given the rugged nature of these products, shipping is not expected to damage a unit. In the unlikely event of a malfunction, Guardian follows the three step procedure below.</p> |
| <p><i>Step I - On-Site Correction</i></p> |
| <ul style="list-style-type: none"> • The most common source of difficulties with a new product is improper installation in one of two ways: incorrect wiring connections or connection to an incorrect power source. |
| <ul style="list-style-type: none"> • Product wiring needs to be properly connected to the on-site wiring. Correct wiring instructions are shown in the user manual included with the product. |
| <ul style="list-style-type: none"> • Connecting a telephone to a standard power source, rather than tip & ring, will blow the telephone's internal, user-replaceable fuse. In the event of fuse burn-out, disconnect the telephone from the power source, replace the fuse, and reconnect following the wiring diagrams provided with the product. |
| <p><i>Step II - Return Materials Authorization (RMA)</i></p> |
| <ul style="list-style-type: none"> • When a product has been installed following user manual instructions, and the unit fails to operate, the user must contact Guardian Telecom to obtain authorization to return the product. This can be done by completing a RMA form online at www.guardiantelecom.com, or by calling the service telephone number given in this manual. |
| <ul style="list-style-type: none"> • After providing information on the product, the owner and the nature of the problem, Guardian will issue a RMA number, to be shown on documentation returned with the product. |
| <ul style="list-style-type: none"> • In addition to the RMA number, shipping documents should include name, address and telephone number of the owner along with contact information for the person responsible for the repair and/or the user who identified the malfunction. |
| <ul style="list-style-type: none"> • (Where a product is being returned for repair from outside of Canada, customs documentation must show the product's serial number, date of export [date of purchase], and a notation that the equipment is: "Canadian goods returning.") |
| <p><i>Step III - Factory Authorized Service</i></p> |
| <ul style="list-style-type: none"> • Once received, each product is carefully inspected and tested. If the product is under warranty, repairs are completed and the product returned to the owner, generally within five working days of receipt by the factory. |
| <ul style="list-style-type: none"> • A product that has been subjected to misuse, neglect or accident or is beyond the warranty period will be evaluated. The service department will provide the owner's representative with a repair cost estimate. Once approved, repairs are completed and the product returned, generally within five working days. |

Notes:

| |
|------------------|
| Model No. |
| Part No. |
| Serial No. |
| Date of Purchase |
| |
| |
| |
| |
| |
| |
| |
| |
| |
| |
| |
| |
| |
| |
| |
| |
| |
| |
| |
| |
| |
| |
| |
| |



**Guardian Telecom Inc.
7552 - 10th Street N.E.
Calgary, Alberta, Canada T2E 8W1
Toll-free 1-800-363-8010
Ph. (403) 258-3100
Fax. (403) 253-4967
www.guardiantelecom.com
E-mail: sales@guardiantelecom.com**

Industrial Communications Worldwide