

Models DRE & DVE - 52/80/120

COMMERCIAL ELECTRIC WATER HEATERS

Dura-Power

• INSTALLATION • OPERATION • MAINTENANCE • LIMITED WARRANTY



⚠ CAUTION

TEXT PRINTED OR UNDERLINED IN RED
CONTAINS INFORMATION RELATIVE TO YOUR
SAFETY. PLEASE READ THOROUGHLY BEFORE
ATTEMPTING ANY CONVERSION.

A.O. Smith
Water Heaters

A DIVISION OF A.O. SMITH CORPORATION
MCBEE, SOUTH CAROLINA
www.hotwater.com

PLACE THESE INSTRUCTIONS ADJACENT TO HEATER AND
NOTIFY OWNER TO KEEP FOR FUTURE REFERENCE.

Rough-in-Dimensions

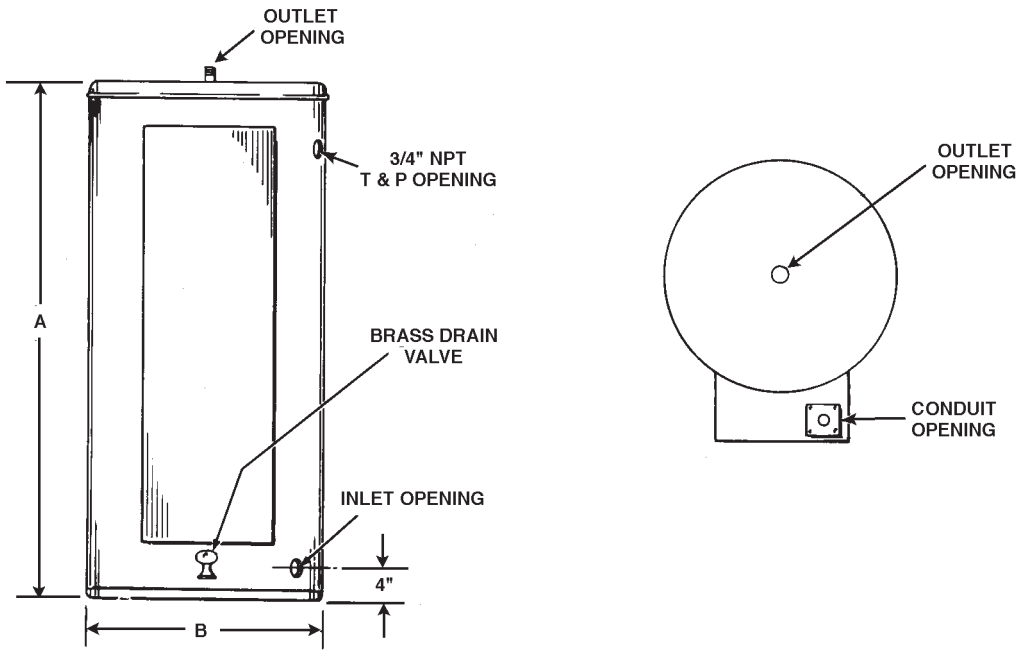

Model Number	Tank Capacity in Gallons	A	B	Inlet/Outlet
DRE/DVE-52	50	55 1/4	21 3/4	1 1/4
DRE/DVE-80	80	59 1/2	25 1/4	1 1/4
DRE/DVE-120	119	62 1/4	29 1/2	1 1/4

Get to know your water heater

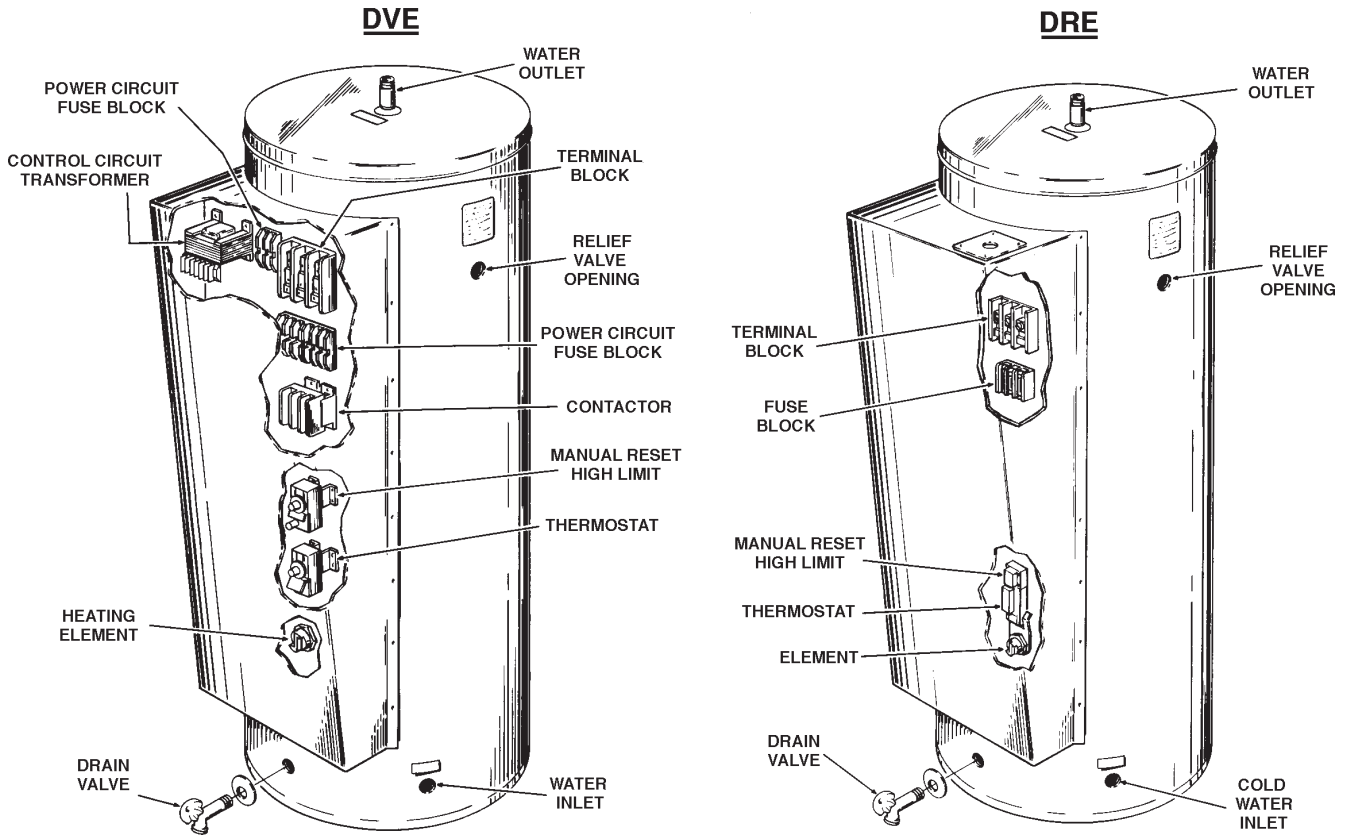

Contents

	Page		Page
ROUGH-IN-DIMENSIONS	2	Amperage Table/Overcurrent Protection	16
GET TO KNOW YOUR WATER HEATER	2	Heater Circuits - DVE Models	16
RECOVERY CAPACITY	3	Control Circuit	16-17
APPROVALS	3	Power Circuit	18-21
MODEL AND RATING PLATE	4	OPERATION	
FOREWORD	4	General	22
GENERAL SAFETY INFORMATION	4	Filling	22
INSTALLATION	5	Startup	22
Required Ability	5	High Temperature Limiting Device	22
General	5	Draining	22
Location	5	Circulating Pump	22
Waterline Connections	5	MAINTENANCE	
Relief Devices	5-6	General	23
Temperature Limiting Control(s)	6	Flushing	23
Temperature Regulation	6	Sediment Removal	23
PIPING DIAGRAMS	7-14	Lime Scale Removal	23-24
ELECTRICAL		Checklist	24
General	14	Replacement Parts	24
Branch Circuit	15	LEAKAGE CHECKPOINTS	25
		LIMITED WARRANTY	26

Recovery Rating

RECOVERY RATE IN GALLONS PER HOUR*
Temperature Rise °F

Models	Standard KW Input	BTU/ Hour	30°	40°	50°	60°	70°	80°	90°	100°	110°	120°	130°	140°
DRE/DVE	6	20,478	82	62	49	41	35	31	27	25	22	21	19	18
DRE/DVE	9	30,717	123	92	74	62	53	46	41	37	34	31	28	26
DRE/DVE	12	40,956	164	123	98	82	70	61	55	49	45	41	38	35
DRE/DVE	13.5	46,075	184	138	111	92	79	69	62	55	50	46	43	40
DRE/DVE	15	51,195	205	154	123	102	88	77	68	61	56	51	47	44
DRE/DVE	18	61,434	246	184	148	123	105	92	82	74	67	61	57	53
DRE/DVE	24	81,912	328	246	197	164	140	123	109	98	89	82	76	70
DRE/DVE	27	92,151	369	276	221	184	158	138	123	111	101	92	85	79
DRE/DVE	30	102,390	410	307	246	205	176	154	137	123	112	102	95	88
DRE/DVE	36	122,868	492	369	295	246	211	184	164	148	134	123	113	105
DRE/DVE	40.5	138,226	554	418	333	277	237	208	185	166	151	138	128	119
DRE/DVE	45	153,585	615	461	369	307	263	230	205	184	168	154	142	132
DRE/DVE	54	184,302	738	553	443	369	316	277	246	221	201	184	170	158

*Figured at 1 KW (3413 Btu) = 4.1 gallons at 100°F temperature rise.
To determine recovery rate per minute, divide recovery rate per hour by 60.

Approvals

All models bear the National Sanitation Foundation seal of approval.



All models are listed by Underwriters Laboratories Inc.



Model and Rating

COMMERCIAL STORAGE TANK WATER HEATER						
MODEL NUMBER	SERIAL NUMBER	ITEM ID / PART NUMBER				
DRE 120 917	J04M008327	9290443004				
VOLTS - AC	PHASE	NO. OF ELEMENTS	WATTS EACH	WATTS TOTAL	CAPACITY U.S. GAL.	MAX. WORKING PRESSURE
480	3	9	6000	54000	119	150
CITY OF NEW YORK DEPT. OF BUILDINGS MEA 173-83-E						
A. O. SMITH WATER PRODUCTS CO. MCBEE, SOUTH CAROLINA, U.S.A.						

Foreword

Detailed installation diagrams are in this manual. These diagrams will serve to provide the installer with a reference for the materials and method of piping suggested. IT IS NECESSARY THAT ALL WATER PIPING AND THE ELECTRICAL WIRING BE INSTALLED AND CONNECTED AS SHOWN IN THE DIAGRAMS.

Particular attention should be given to the installation of thermometers at the locations indicated in the diagrams as these are necessary for checking the operation of the heater.

In addition to these instructions, the equipment shall be installed in accordance with those installation regulations in force in the local area where the installation is to be made. Authorities having

jurisdiction shall be consulted before installations are made.

BE SURE TO TURN OFF POWER WHEN WORKING ON OR NEAR THE ELECTRICAL SYSTEM OF THE HEATER. NEVER TOUCH ELECTRICAL COMPONENTS WITH WET HANDS OR WHEN STANDING IN WATER. WHEN REPLACING FUSES ALWAYS USE THE CORRECT SIZE FOR THE CIRCUIT. SEE PAGE 16 THROUGH 21.

The principal components of the heater are identified on page 2. The model and rating plate on page 4 interprets certain markings into useful information. Both of these references should be used to identify the heater, its components and optional equipment.

General Safety Information

PRECAUTIONS

DO NOT USE THIS APPLIANCE IF ANY PART HAS BEEN UNDER WATER. Immediately call a qualified service technician to inspect the appliance and to replace any part of the control system and any gas control which has been under water.

IF THE UNIT IS EXPOSED TO THE FOLLOWING, DO NOT OPERATE HEATER UNTIL ALL CORRECTIVE STEPS HAVE BEEN MADE BY A QUALIFIED SERVICEMAN.

1. EXTERNAL FIRE.
2. DAMAGE.
3. FIRING WITHOUT WATER.

GROUNDING INSTRUCTIONS

This water heater must be grounded in accordance with the National Electric Code and/or local codes. These must be followed in all cases.

This water heater must be connected to a grounded metal, permanent wiring system; or an equipment grounding conductor must be run with the circuit conductors and connected to the equipment grounding terminal or lead on the water heater.

HYDROGEN GAS (FLAMMABLE)



HYDROGEN GAS CAN BE PRODUCED IN A HOT WATER SYSTEM SERVED BY THIS HEATER THAT HAS NOT BEEN USED FOR A LONG PERIOD OF TIME (GENERALLY TWO WEEKS OR MORE). HYDROGEN GAS IS EXTREMELY FLAMMABLE. To reduce the risk of injury under these conditions, it is recommended

that the hot water faucet be opened for several minutes at the kitchen sink before using any electrical appliance connected to the hot water system. If hydrogen is present there will probably be an unusual sound such as air escaping through the pipe as the water begins to flow. **THERE SHOULD BE NO SMOKING OR OPEN FLAME NEAR THE FAUCET AT THE TIME IT IS OPEN.**

INSULATION BLANKETS

Insulation blankets available to the general public for external use on water heaters are not approved for use on your A.O. Smith water heater. The purpose of an insulation blanket is to reduce the standby heat loss encountered with storage tank water heaters. Your A.O. Smith water heater meets or exceeds the ASHRAE/IES 90.1b 1992 standards with respect to insulation and standby loss requirements, making an insulation blanket unnecessary.



Should you choose to apply an insulation blanket to this heater, you should follow these instructions (See "Getting to know your water heater" on page 2 for identification of components mentioned below). Failure to follow these instructions can result in fire, asphyxiation, serious personal injury or death.

- **Do not** cover the temperature & pressure relief valve.
- **Do not** cover the instruction manual. Keep it on the side of the water heater or nearby for future reference.
- **Do** obtain new labels from A.O. Smith for placement on the blanket directly over the existing labels.



FAILURE TO FOLLOW THESE INSTRUCTIONS CAN RESULT IN SERIOUS PERSONAL INJURY OR DEATH.

Installation

REQUIRED ABILITY

INSTALLATION OR SERVICE OF THIS WATER HEATER REQUIRES ABILITY EQUIVALENT TO THAT OF A LICENSED TRADESMAN IN THE FIELD INVOLVED. PLUMBING AND ELECTRICAL WORK ARE INVOLVED.

GENERAL

The installation must conform to these instructions and the local code authority having jurisdiction. Grounding and electrical wiring connected to the water heater must also conform to the current version of the National Electrical Code NFPA-70 or for Canadian requirements the current version of the Canadian Electric Code, CAN/CSA-C22.2 No. M91. These codes may be obtained from the following institutes; The NFPA-70 is available from the National Fire Protection Association, 1 Batterymarch Park, Quincy, MA 02269. The CAN/CSA C22.2 No. M91 is available from the Canadian Standards Association, 178 Rexdale Blvd., Toronto Ontario, Canada M9W 1R3.

If your location requires the installation of the water heater to comply with National Sanitation Foundation requirements, the heater must be sealed to the floor so as to prevent seepage underneath the heater. The following are recommended sealants that may be used on all types of flooring except concrete GE Silicone Seal RTV-120, 103, 108, and 109.

LOCATION

For proper installation, the heater should be installed on a level surface.

LOCATE THE WATER HEATER NEAR A FLOOR DRAIN. THE HEATER SHOULD BE LOCATED IN AN AREA WHERE LEAKAGE FROM THE HEATER OR CONNECTIONS WILL NOT RESULT IN DAMAGE TO THE ADJACENT AREA OR TO LOWER FLOORS OF THE STRUCTURE.

WHEN SUCH LOCATIONS CANNOT BE AVOIDED, A SUITABLE DRAIN PAN SHOULD BE INSTALLED UNDER THE HEATER. Such pans should be fabricated with sides at least 2" deep, with length and width at least 2" greater than the diameter of the heater and must be piped to an adequate drain. Drain pans suitable for these heaters are available from your distributor or Product Service Division, A.O. Smith Water Heater Parts Fulfillment, 125 Southeast Parkway, Franklin, TN 37068.

Water heater life depends upon water quality, water pressure and the environment in which the water heater is installed. Water heaters are sometimes installed in locations where leakage may result in property damage, even with the use of a drain pan piped to a drain. However, unanticipated damage can be reduced or prevented by a leak detector or water shut-off device used in conjunction with a piped drain pan. These devices are available from some plumbing supply wholesalers and retailers, and detect and react to leakage in various ways:

- Sensors mounted in the drain pan that trigger an alarm or turn off the incoming water to the water heater when leakage is detected.
- Sensors mounted in the drain pan that turn off the water supply to the entire home when water is detected in the drain pan.
- Water supply shut-off devices that activate based on the water pressure differential between the cold water and hot water pipes connected to the water heater.
- Devices that will turn off the gas supply to a gas water heater while at the same time shutting off its water supply.

Locate the heater close to the point of major hot water usage and the power supply.

- Try to make hot water piping and branch circuit wiring as short as possible.
- Insulate hot and cold water piping where heat loss and condensation may be a problem.

THE HEATER SHOULD NOT BE LOCATED IN AN AREA WHERE IT WILL BE SUBJECT TO FREEZING.

Suggested clearances from adjacent surfaces are 18 inches in front for access to the controls and elements and 12 inches from top. The heater may be installed on or against combustible surfaces.

WATER LINE CONNECTIONS

This manual provides detailed installation diagrams (see back section of this manual) for typical methods of application for the water heaters. The water heater may be installed by itself, or with a separate storage tank, on both single and two-temperature systems. When used with a separate storage tank, the circulation may be either by gravity or by means of a circulating pump. When a circulating pump is used it is important to note that the flow rate should be slow so that there will be a minimum of turbulence inside the heater.



CAUTION

A closed system will exist if a check valve, pressure reducing valve, or a water meter is installed in the cold water line between the water heater and street main (or well).

Excessive pressure may develop causing premature tank failure or intermittent relief valve operation. *This type of failure is not covered by the limited warranty.* An expansion tank may be required in the inlet supply line between the appliance and the meter or valve to compensate for the thermal expansion of water.

If a water heater is installed in a closed water system, contact the water supplier or local plumbing inspector on how to control this situation.

RELIEF DEVICES



CAUTION

TO REDUCE THE RISK OF EXCESSIVE PRESSURES AND TEMPERATURE IN THIS WATER HEATER, INSTALL TEMPERATURE AND PRESSURE PROTECTIVE EQUIPMENT REQUIRED BY LOCAL CODES but not less than a combination temperature and pressure relief valve certified by a nationally recognized testing laboratory that maintains periodic inspection of production of listed equipment or materials, as meeting the requirements for Relief Valves for Hot Water Supply Systems, ANSI Z21.22 /CSA 4.4 (current version).

This valve must be marked with a maximum set pressure not to exceed the marked maximum working pressure of the water heater. **INSTALL THE VALVE INTO AN OPENING PROVIDED AND MARKED FOR THIS PURPOSE IN THE WATER HEATER, AND ORIENT IT OR PROVIDE TUBING SO THAT ANY DISCHARGE FROM THE VALVE WILL EXIST ONLY WITHIN 6 INCHES ABOVE, OR AT ANY DISTANCE BELOW THE STRUCTURAL FLOOR AND CANNOT CONTACT ANY LIVE ELECTRICAL PART. THIS DISCHARGE OPENING MUST NOT BE BLOCKED OR REDUCED IN SIZE UNDER ANY CIRCUMSTANCES.**

The pressure setting of the relief valve should not exceed the pressure capacity of any component in the system. The temperature setting of the relief valve should not exceed 210°F.

An unplugged 3/4" relief valve opening is provided for installing temperature and pressure relief valve.

TEMPERATURE LIMITING CONTROL(S)

Both the DVE and DRE model water heaters incorporate high temperature cutoffs. In the event of high temperature cutoff operation, the reason for the operation of the high temperature cutoff operation must be determined and corrected. Once the situation has been corrected the high temperature cutoff(s) may be reset in the following manner:

DVE Models

The DVE models have a single immersion-type high temperature cutoff control in the control circuit, see DVE CONTROL CIRCUIT DIAGRAMS. This high temperature cutoff is factory set to open at 190°F (88°C). To manually reset the control you must:

1. Disconnect the power to the heater.
2. Allow the tank to cool to approximately 120°F.
3. Remove the front control cover.
4. Press the manual reset button. The control will not reset until it has cooled approximately 50°F (28°C).

DRE Models

The DRE models have multiple surface mounted combination high temperature cutoff and thermostat controls. There is one of these combination high temperature cutoff and thermostat controls for each element in a DRE model, see DRE CIRCUIT DIAGRAMS. Each of the high temperature controls is of the manual reset type. To manually reset the controls:

1. Disconnect the power to the heater.
2. Allow the tank to cool approximately 160°F.
3. Remove the front control cover.
4. Press the manual reset button on each of the effected controls. The control will not reset until it has cooled approximately 30°F (17°C).

Once the control(s) has been reset the control cover should be replaced prior to operating the heater.

TEMPERATURE REGULATION

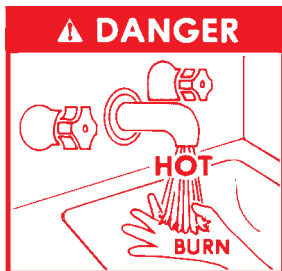

THIS WATER HEATER IS EQUIPPED WITH AN ADJUSTABLE THERMOSTAT TO CONTROL WATER TEMPERATURE. HOT WATER TEMPERATURES REQUIRED FOR AUTOMATIC DISHWASHER AND LAUNDRY USE CAN CAUSE SCALD BURNS RESULTING IN SERIOUS PERSONAL INJURY AND/OR DEATH. THE TEMPERATURE AT WHICH INJURY OCCURS VARIES WITH THE PERSONS AGE AND TIME OF EXPOSURE. THE SLOWER RESPONSE TIME OF CHILDREN, AGED, OR DISABLED PERSONS INCREASES THE HAZARDS TO THEM. NEVER ALLOW

SMALL CHILDREN TO USE A HOT WATER TAP, OR TO DRAW THEIR OWN BATH WATER. NEVER LEAVE A CHILD OR DISABLED PERSON UNATTENDED IN A BATH TUB OR SHOWER.

THE WATER HEATER SHOULD BE LOCATED IN AN AREA WHERE THE GENERAL PUBLIC DOES NOT HAVE ACCESS TO SET TEMPERATURES.

SETTING THE WATER HEATER TEMPERATURES AT 120°F WILL REDUCE THE RISK OF SCALDS. Some states require settings at specific lower temperatures.

The water temperature is controlled in the DVE models with a single thermostat located on the right front of the heater, just inside the control cabinet. This control is set at 140°F at the factory and has a fixed 5°F differential. The DRE models have multiple thermostats depending on the configuration purchased. These thermostats are also set at 140°F and have a 5-15°F differential. A.O. Smith recommends setting the dial at the lowest setting which produces an acceptable hot water supply. This will always give the most energy efficient operation.

Figure 1 shows the approximate time-to-burn relationship for normal adult skin.

Valves for reducing point-of-use temperature by mixing cold and hot water are available. Also available are inexpensive devices that attach to faucets to limit hot water temperatures. Contact a licensed plumber or the local plumbing authority.

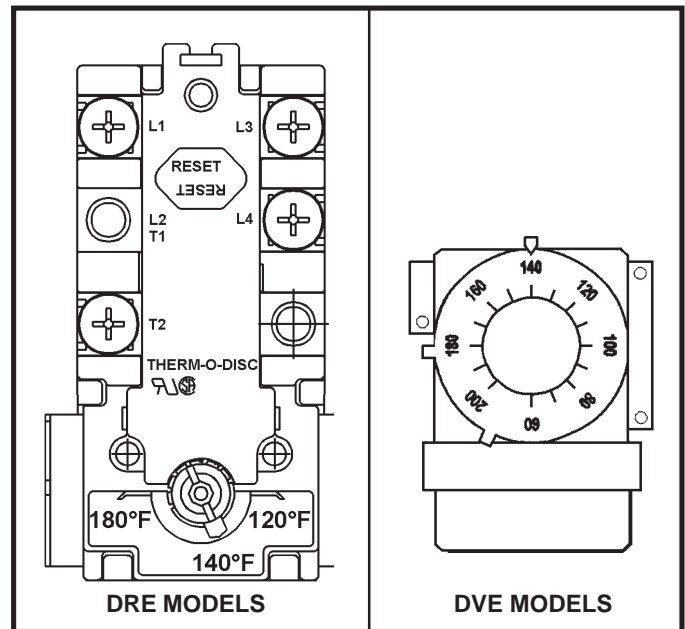

Temperature Setting	Time to produce 2nd & 3rd Degree burns on adult skin
180°F	Nearly instantaneous
170°F	Nearly instantaneous
160°F	About 1/2 second
150°F	About 1-1/2 seconds
140°F	Less than 5 seconds
130°F	About 30 seconds
120°F	More than 5 minutes

FIGURE 1

Piping Diagrams

ONE TEMPERATURE WITH CIRCULATING LOOP

MIXING VALVE APPLICATION FOR TWO TEMPERATURE WATER

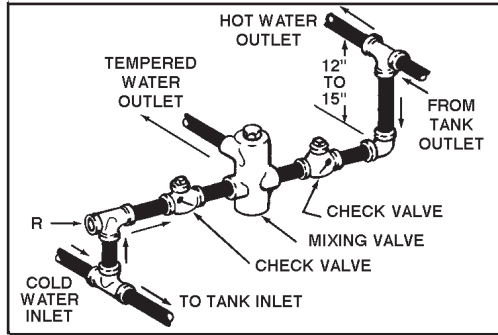

CIRCULATING RETURN LINE CONNECTIONS
TEMPERED WATER LOOP, IF USED, CONNECT TO POINT R.

BOOSTER WITH CIRCULATING LOOP

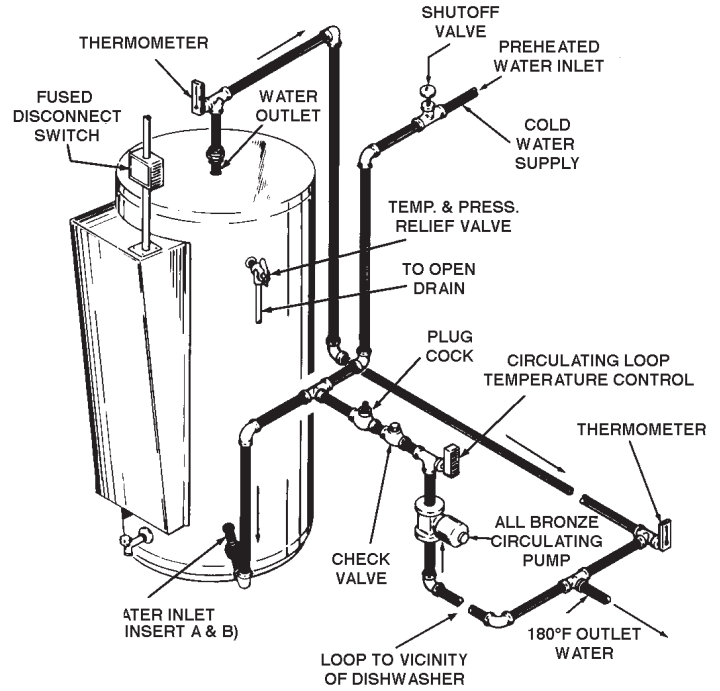

ONE TEMPERATURE

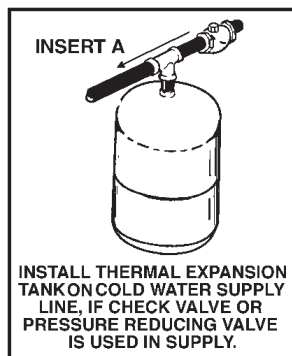
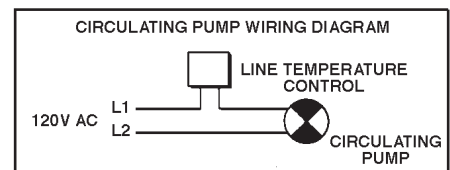
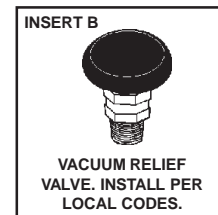
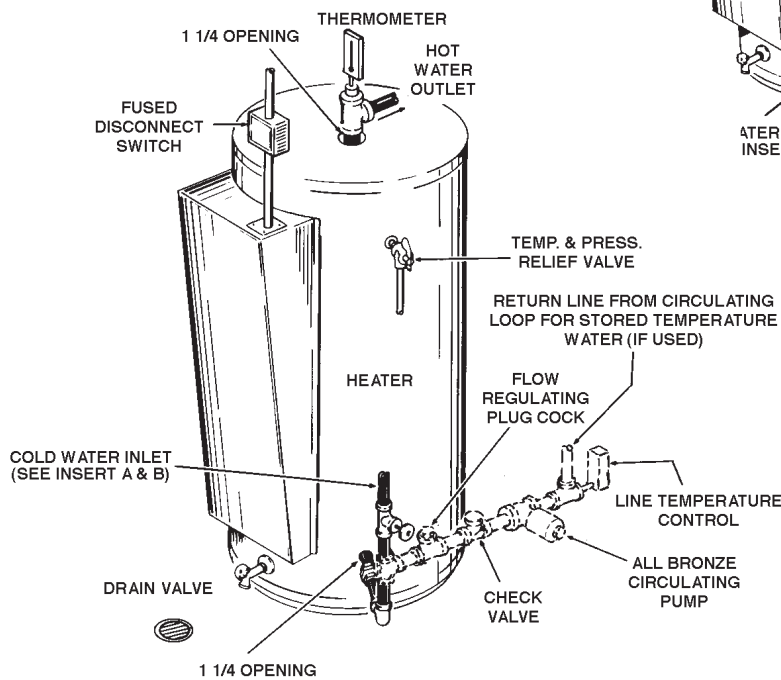

⚠ DANGER

TEMPERATURE SETTING SHOULD NOT EXCEED SAFE TEMPERATURE AT FIXTURES. SEE WATER TEMPERATURE CONTROL WARNING ON PAGE 6. IF HIGHER PREHEAT TEMPERATURES ARE NECESSARY TO OBTAIN ADEQUATE BOOSTER OUTPUT, ADD AN ANTI-SCALD VALVE FOR HOT WATER SUPPLIED TO FIXTURES.

CAUTION: IF BUILDING COLD WATER SUPPLY HAS A BACK-FLOW PREVENTER, CHECK VALVE OR WATER METER WITH CHECK VALVE. PROVISIONS FOR THERMAL EXPANSION OF WATER IN THE HOT WATER SYSTEM MUST BE PROVIDED.

*PIPE TO OPEN DRAIN
INSTALL IN ACCORDANCE WITH ALL LOCAL CODES.

TWO HEATERS WITH OR WITHOUT MIXING VALVE WITH OR WITHOUT BUILDING RECIRCULATION

MIXING VALVE APPLICATION FOR TWO TEMPERATURE WATER

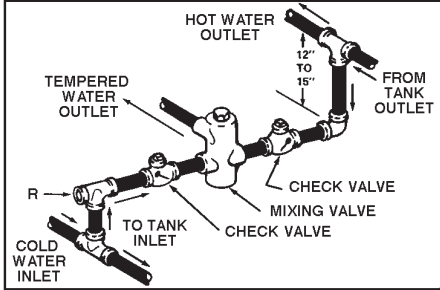

CIRCULATING RETURN LINE CONNECTIONS
TEMPERED WATER LOOP, IF USED, CONNECT TO POINT R.

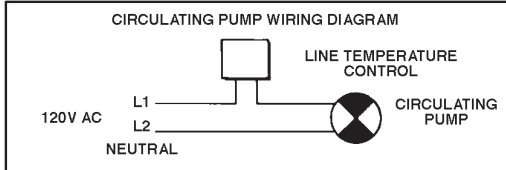

CAUTION: IF BUILDING COLD WATER SUPPLY HAS A BACK-FLOW PREVENTER, CHECK VALVE OR WATER METER WITH CHECK VALVE, PROVISIONS FOR THERMAL EXPANSION OF WATER IN THE HOT WATER SYSTEM MUST BE PROVIDED.

*PIPE TO OPEN DRAIN

INSTALL IN ACCORDANCE WITH ALL LOCAL CODES.

RETURN FROM CIRCULATING LOOP FOR STORED TEMPERATURE WATER (IF USED)

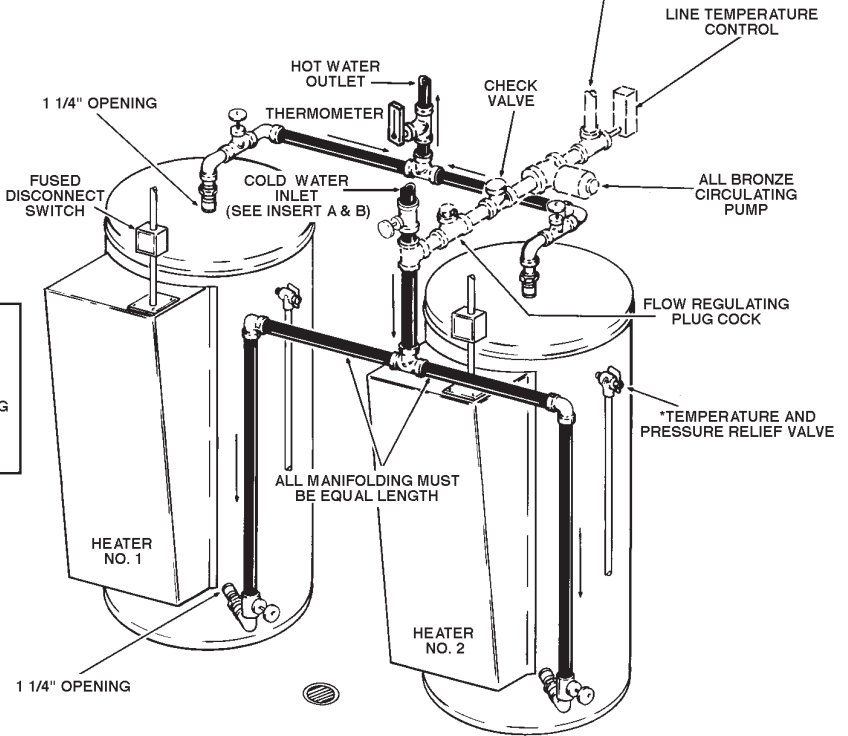

MUST BE IDENTICAL HEATERS

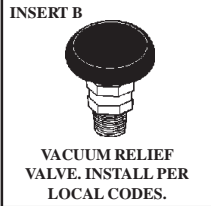

⚠ DANGER

TEMPERATURE SETTING SHOULD NOT EXCEED SAFE TEMPERATURE AT FIXTURES. SEE WATER TEMPERATURE CONTROL WARNING ON PAGE 6. IF HIGHER PREHEAT TEMPERATURES ARE NECESSARY TO OBTAIN ADEQUATE BOOSTER OUTPUT, ADD AN ANTI-SCALD VALVE FOR HOT WATER SUPPLIED TO FIXTURES.

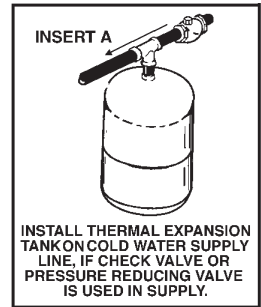

THREE HEATERS WITH OR WITHOUT MIXING VALVE WITH OR WITHOUT BUILDING RECIRCULATION

MIXING VALVE APPLICATION FOR TWO TEMPERATURE WATER

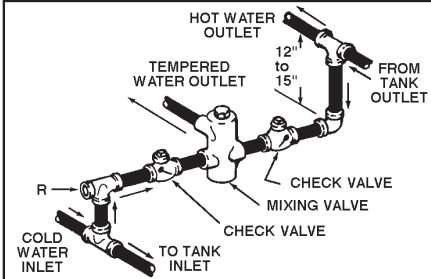

CIRCULATING RETURN LINE CONNECTION
TEMPERED WATER LOOP, IF USED, CONNECT TO POINT R.

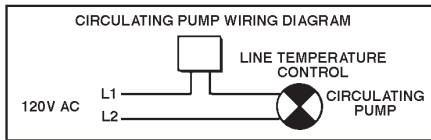

CAUTION: IF BUILDING COLD WATER SUPPLY HAS A BACK-FLOW PREVENTER, CHECK VALVE OR WATER METER WITH CHECK VALVE, PROVISIONS FOR THERMAL EXPANSION OF WATER IN THE HOT WATER SYSTEM MUST BE PROVIDED.

*PIPE TO OPEN DRAIN

INSTALL IN ACCORDANCE WITH ALL LOCAL CODES

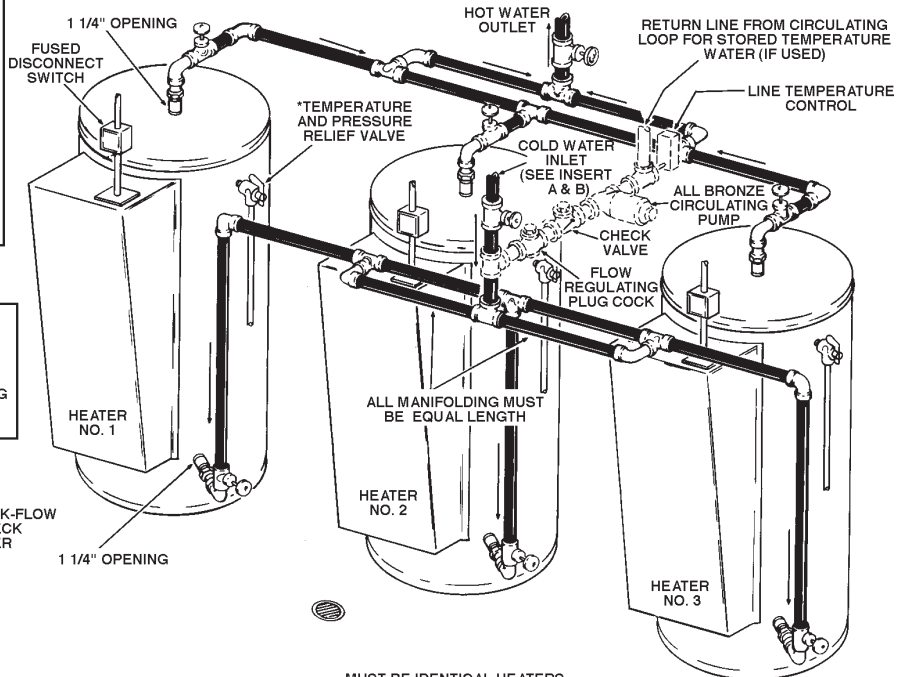

MUST BE IDENTICAL HEATERS

FOUR HEATERS WITH OR WITHOUT MIXING VALVE WITH OR WITHOUT BUILDING RECIRCULATION

MUST BE IDENTICAL HEATERS

CAUTION: IF BUILDING COLD WATER SUPPLY HAS A BACK-FLOW PREVENTER, CHECK VALVE OR WATER METER WITH CHECK VALVE, PROVISIONS FOR THERMAL EXPANSION OF WATER IN THE HOT WATER SYSTEM MUST BE PROVIDED.

*PIPE TO OPEN DRAIN
INSTALL IN ACCORDANCE WITH ALL LOCAL CODES.

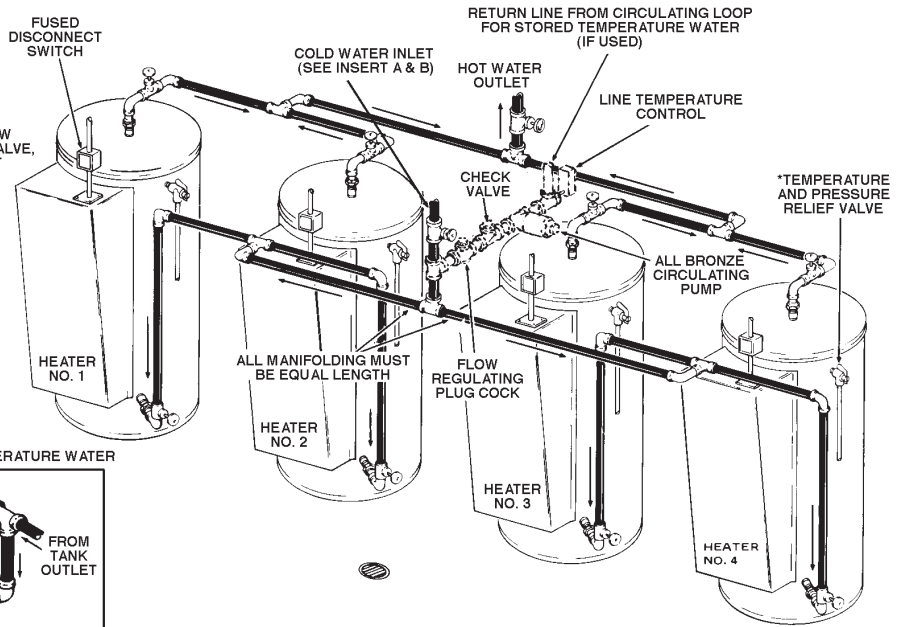

MIXING VALVE APPLICATION FOR TWO TEMPERATURE WATER

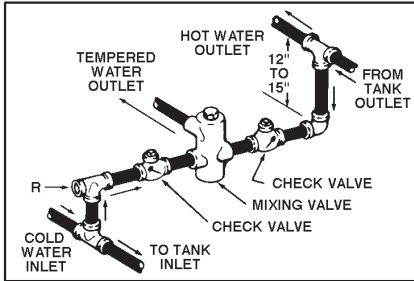

CIRCULATING RETURN LINE CONNECTIONS
TEMPERED WATER LOOP, IF USED, CONNECT TO POINT R.

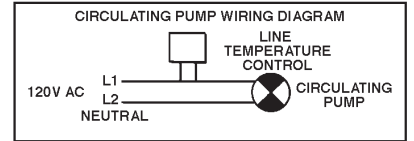
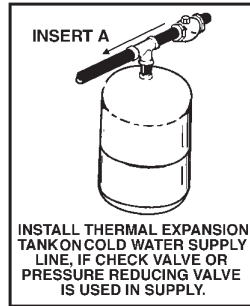

⚠ DANGER

TEMPERATURE SETTING SHOULD NOT EXCEED SAFE TEMPERATURE AT FIXTURES. SEE WATER TEMPERATURE CONTROL WARNING ON PAGE 6. IF HIGHER PREHEAT TEMPERATURES ARE NECESSARY TO OBTAIN ADEQUATE BOOSTER OUTPUT, ADD AN ANTI-SCALD VALVE FOR HOT WATER SUPPLIED TO FIXTURES.

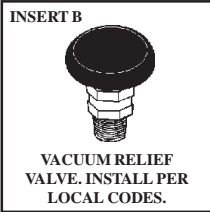

TWO TEMPERATURE WITH 180° CIRCULATING LOOP AND STORAGE TANK

CAUTION: IF BUILDING COLD WATER SUPPLY HAS A BACK-FLOW PREVENTER, CHECK VALVE OR WATER METER WITH CHECK VALVE, PROVISIONS FOR THERMAL EXPANSION OF WATER IN THE HOT WATER SYSTEM MUST BE PROVIDED.

*PIPE TO OPEN DRAIN
INSTALL IN ACCORDANCE WITH ALL LOCAL CODES.

NOTES:

1. TANK TEMPERATURE CONTROL SET AT DESIRED TEMPERATURE (MAXIMUM 150°F)
2. HEATER THERMOSTAT SET AT 180°F
3. SYSTEM PUMP AND FLO-PAC FITTING SIZED TO MAXIMUM OF ONE 54KW HEATER.
4. 3/4" SYSTEM PIPING BETWEEN HEATER AND TANK.

WIRING DIAGRAM
FIXTURE CIRCULATING LOOP (IF USED)

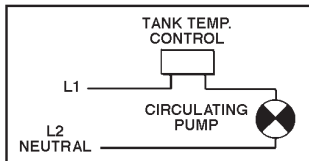

CIRCULATING PUMP WIRING DIAGRAM

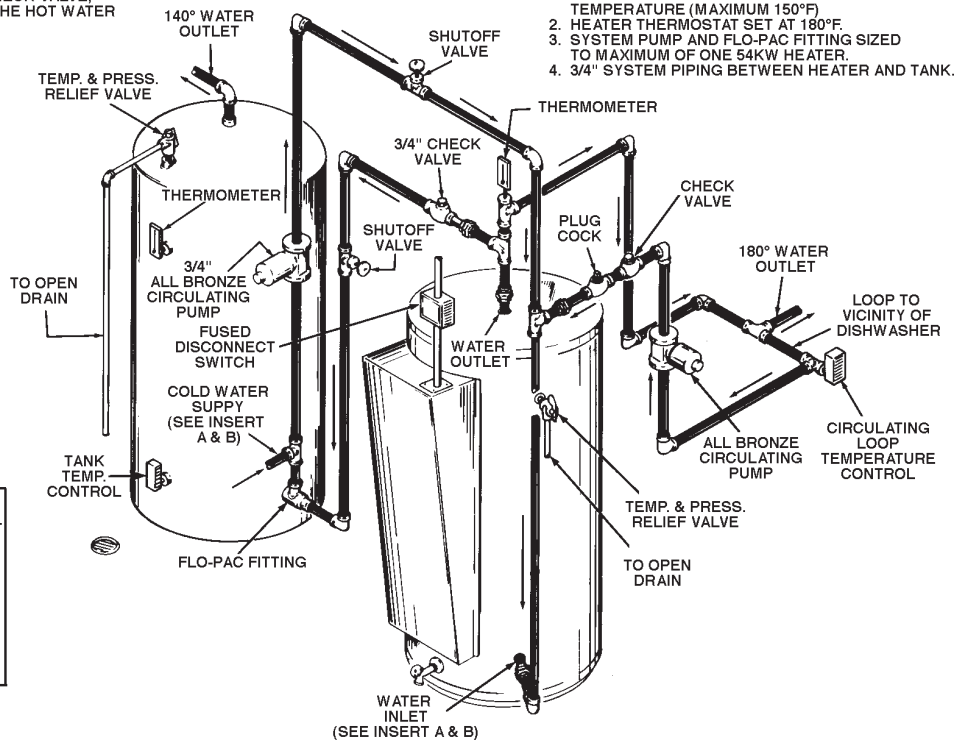
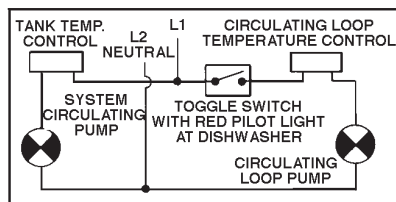

ONE TEMPERATURE ONE HEATER VERTICAL STORAGE TANK FORCED CIRCULATION WITHOUT BUILDING RECIRCULATION

- NOTES:
1. TANK TEMPERATURE CONTROL SET AT DESIRED TEMPERATURE (MAXIMUM 150°F).
 2. HEATER THERMOSTAT SET AT 180°F.
 3. 3/4" PUMP AND RETURN PIPING FROM TANK TO HEATER ARE ADEQUATE FOR ONE OR TWO HEATERS UP TO 54KW.
 4. RETURN LINE FROM CIRCULATING LOOP (IF USED) SHOULD CONNECT TO COLD WATER SUPPLY PIPE.

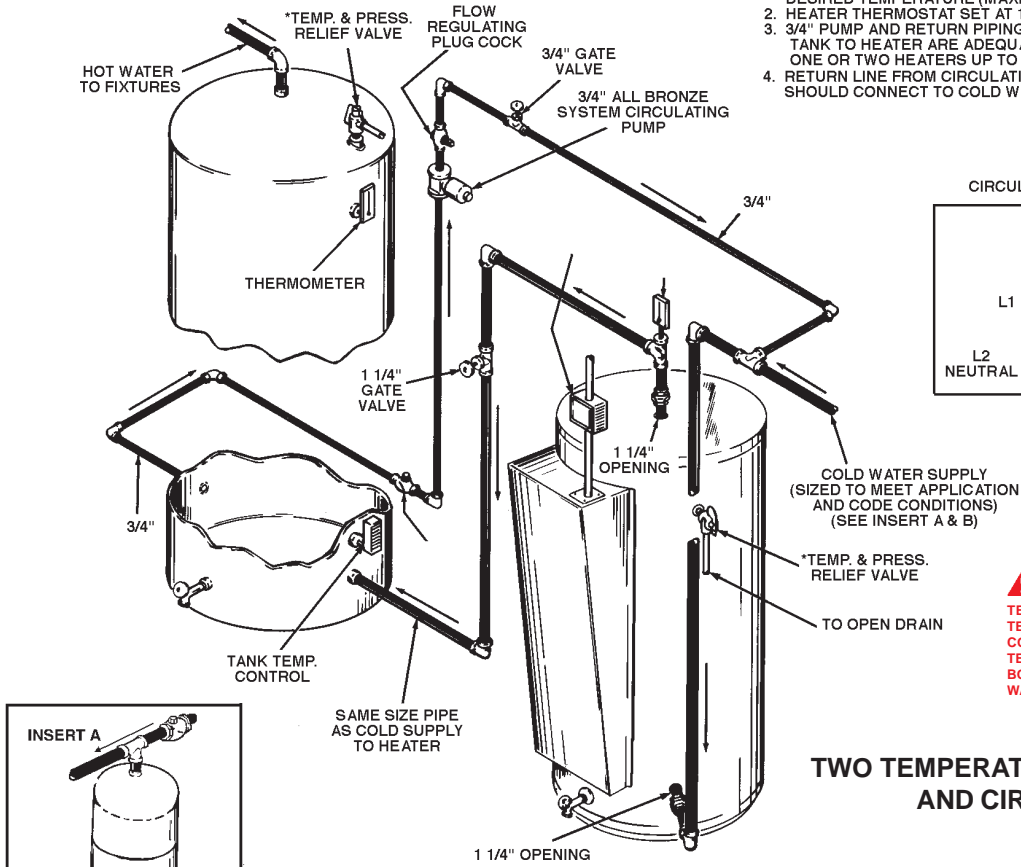
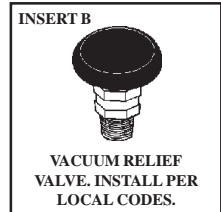

CIRCULATING PUMP WIRING DIAGRAM

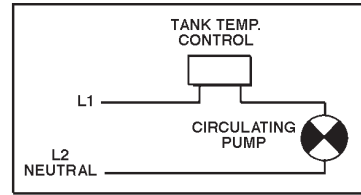

⚠ DANGER
TEMPERATURE SETTING SHOULD NOT EXCEED SAFE TEMPERATURE AT FIXTURES. SEE WATER TEMPERATURE CONTROL WARNING ON PAGE 6. IF HIGHER PREHEAT TEMPERATURES ARE NECESSARY TO OBTAIN ADEQUATE BOOSTER OUTPUT, ADD AN ANTI-SCALD VALVE FOR HOT WATER SUPPLIED TO FIXTURES.

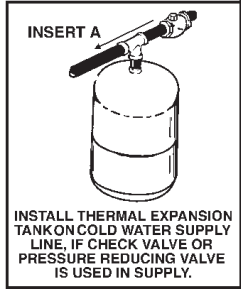

CAUTION: IF BUILDING COLD WATER SUPPLY HAS A BACK-FLOW PREVENTER, CHECK VALVE OR WATER METER WITH CHECK VALVE, PROVISIONS FOR THERMAL EXPANSION OF WATER IN THE HOT WATER SYSTEM MUST BE PROVIDED.

*PIPE TO OPEN DRAIN
INSTALL IN ACCORDANCE WITH ALL LOCAL CODES

TWO TEMPERATURE WITH MIXING VALVE AND CIRCULATING LOOP

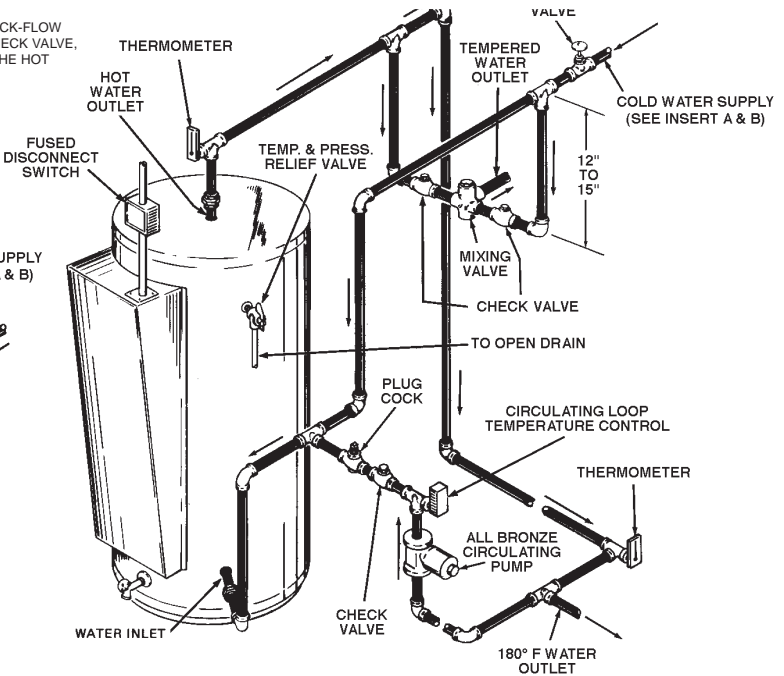

CIRCULATING PUMP WIRING DIAGRAM

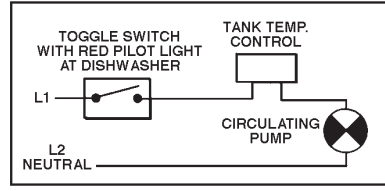

TWO TEMPERATURE WITH MIXING VALVE

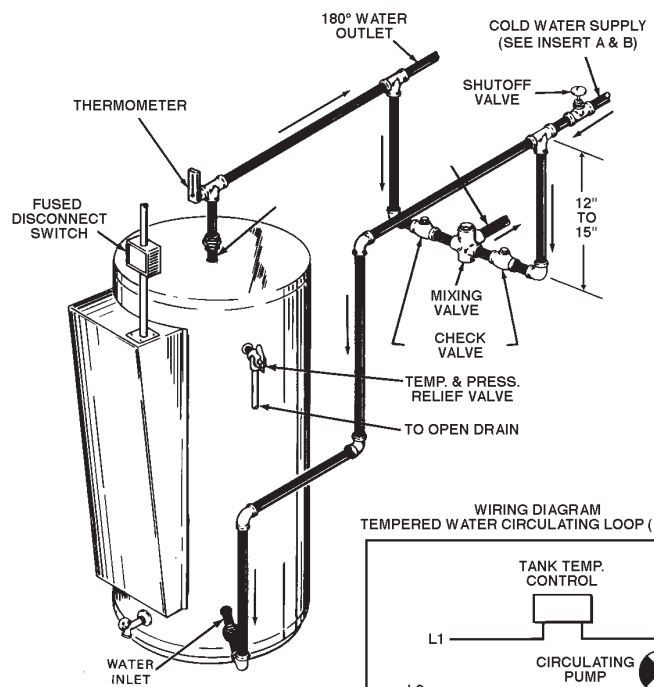

WIRING DIAGRAM
TEMPERED WATER CIRCULATING LOOP (IF USED)

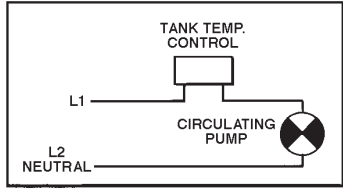

TWO HEATER WITH VERTICAL STORAGE TANK WITH OR WITHOUT BUILDING RECIRCULATION

CIRCULATING PUMP WIRING DIAGRAM

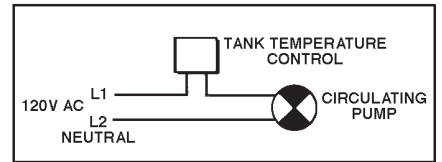

RETURN LINE FROM FIXTURE CIRCULATING LOOP (IF USED) SHOULD CONNECT TO ANY OPENING NEAR BOTTOM OF TANK.

*PIPE RELIEF VALVE TO OPEN DRAIN

† TANK TEMPERATURE CONTROL SET AT DESIRED TEMPERATURE (MAX. 170°). HEATER THERMOSTAT SET AT LEAST 5° HIGHER.

INSTALL IN ACCORDANCE WITH ALL LOCAL CODES.

CAUTION: IF BUILDING COLD WATER SUPPLY HAS A BACK-FLOW PREVENTER, CHECK VALVE OR WATER METER WITH CHECK VALVE, PROVISIONS FOR THERMAL EXPANSION OF WATER IN THE HOT WATER TANK SYSTEM MUST BE PROVIDED.

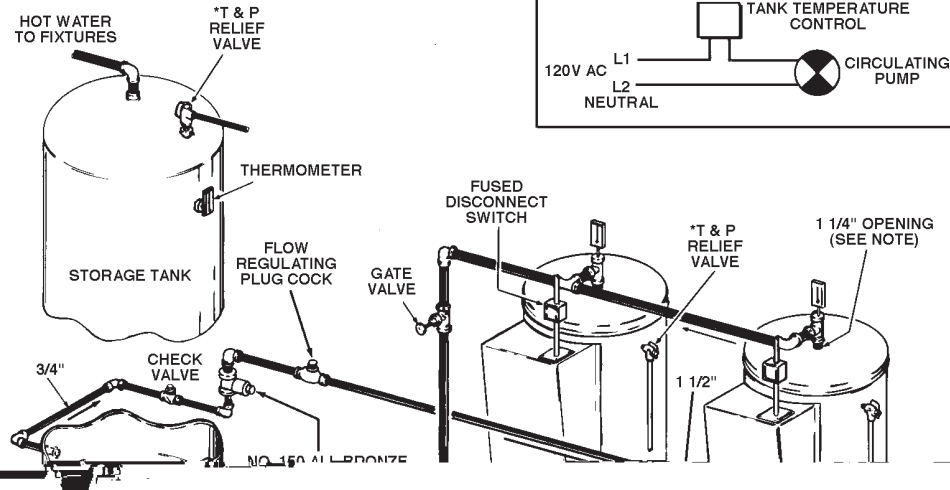

TEMPERATURE SETTING SHOULD NOT EXCEED SAFE TEMPERATURE AT FIXTURES. SEE WATER TEMPERATURE CONTROL WARNING ON PAGE 6. IF HIGHER PREHEAT TEMPERATURES ARE NECESSARY TO OBTAIN ADEQUATE BOOSTER OUTPUT, ADD AN ANTI-SCALD VALVE FOR HOT WATER SUPPLIED TO FIXTURES.

INSERT B

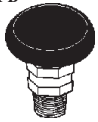

VACUUM RELIEF VALVE. INSTALL PER LOCAL CODES.

CIRCULATING PUMP WIRING DIAGRAM

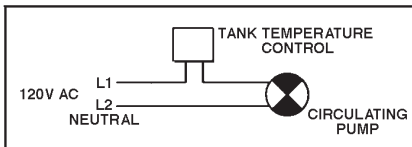

TWO HEATERS WITH HORIZONTAL STORAGE TANK WITH OR WITHOUT BUILDING RECIRCULATION

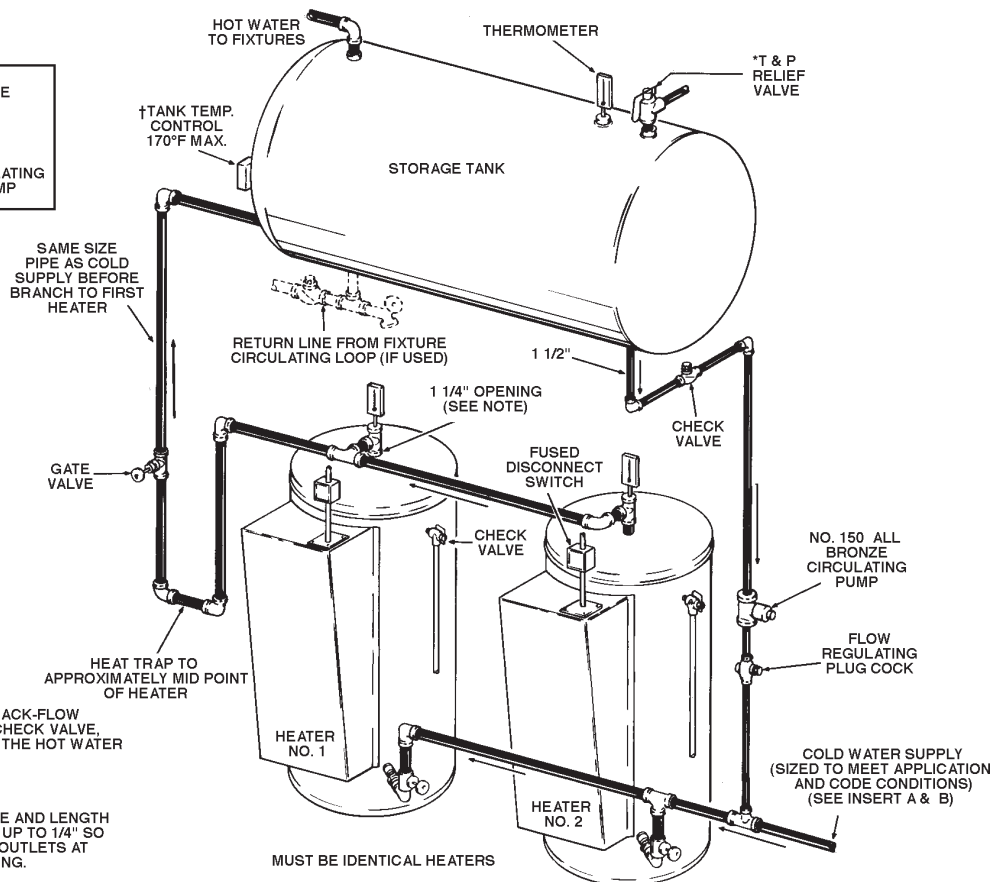
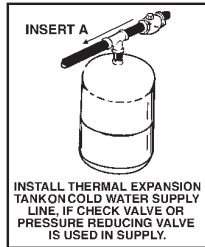

*PIPE RELIEF VALVE TO OPEN DRAIN

† TANK TEMPERATURE CONTROL SET AT DESIRED TEMPERATURE (MAX. 170°F). HEATER THERMOSTAT SET AT LEAST 5° HIGHER.

INSTALL IN ACCORDANCE WITH ALL LOCAL CODES.

CAUTION: IF BUILDING COLD WATER SUPPLY HAS A BACK-FLOW PREVENTER, CHECK VALVE OR WATER METER WITH CHECK VALVE, PROVISIONS FOR THERMAL EXPANSION OF WATER IN THE HOT WATER SYSTEM MUST BE PROVIDED.

NOTE:

BRANCH PIPING TO ALL HEATERS MUST BE SAME SIZE AND LENGTH FOR EQUAL FLOW. THESE BRANCHES MAY BE SIZED UP TO 1/4" SO THAT CROSS SECTIONAL AREAS OF ALL INLETS AND OUTLETS AT LEAST EQUAL AREA OF THEIR RESPECTIVE MAIN PIPING.

REVERSE RETURN PIPING SHOWN

THREE HEATERS WITH VERTICAL STORAGE TANK WITH OR WITHOUT BUILDING RECIRCULATION

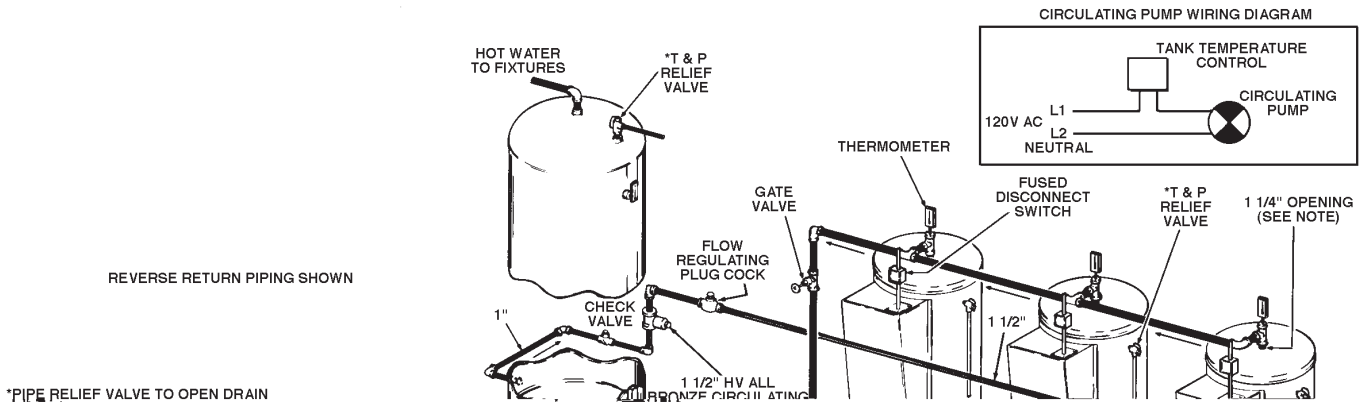

REVERSE RETURN PIPING SHOWN

*PIPE RELIEF VALVE TO OPEN DRAIN

CIRCULATING PUMP WIRING DIAGRAM

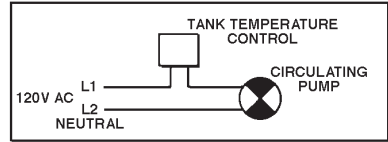

DANGER

TEMPERATURE SETTING SHOULD NOT EXCEED SAFE TEMPERATURE AT FIXTURES. SEE WATER TEMPERATURE CONTROL WARNING ON PAGE 6. IF HIGHER PREHEAT TEMPERATURES ARE NECESSARY TO OBTAIN ADEQUATE BOOSTER OUTPUT, ADD AN ANTI-SCALD VALVE FOR HOT WATER SUPPLIED TO FIXTURES.

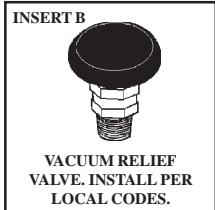
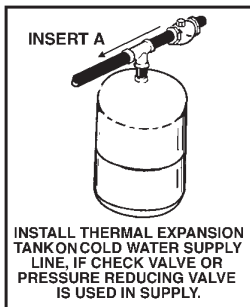

THREE HEATERS WITH HORIZONTAL STORAGE TANK WITH OR WITHOUT BUILDING RECIRCULATION

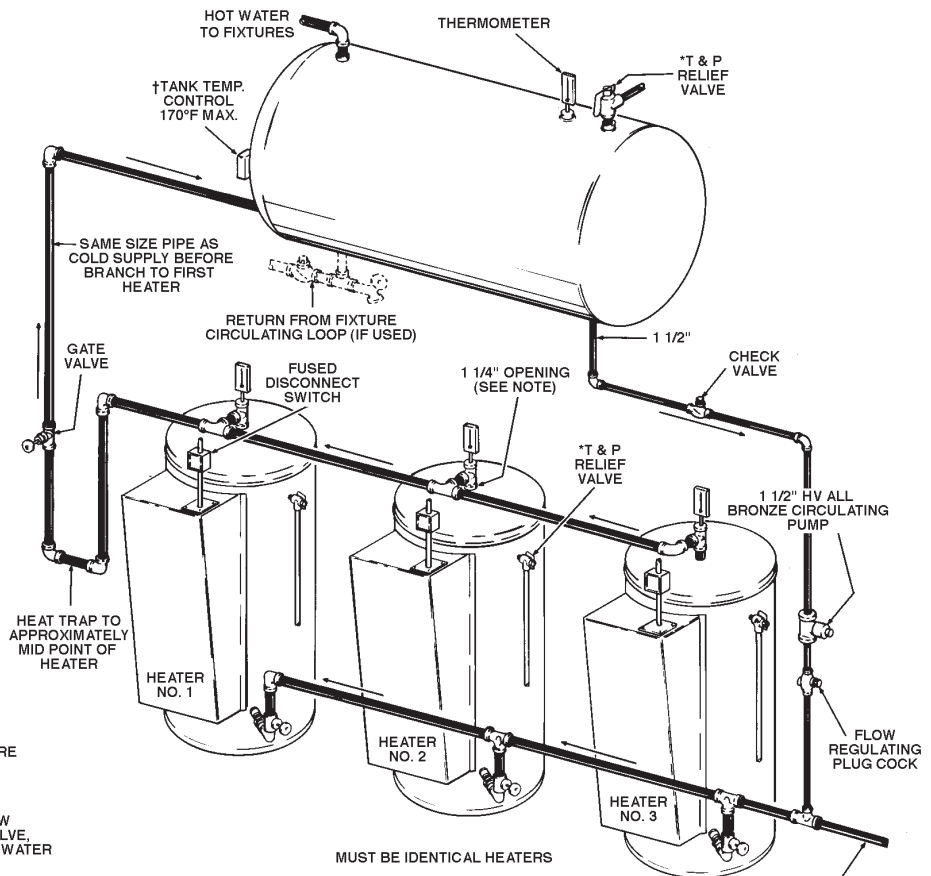

CIRCULATING PUMP WIRING DIAGRAM

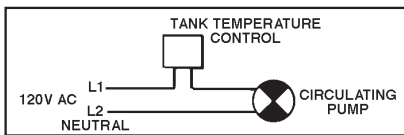

REVERSE RETURN PIPING SHOWN

*PIPE RELIEF VALVE TO OPEN DRAIN

†TANK TEMPERATURE CONTROL SET AT DESIRED TEMPERATURE (MAX. 170°F). HEATER THERMOSTAT SET AT LEAST 5° HIGHER

CAUTION: IF BUILDING COLD WATER SUPPLY HAS A BACK-FLOW PREVENTER, CHECK VALVE OR WATER METER WITH CHECK VALVE, PROVISIONS FOR THERMAL EXPANSION OF WATER IN THE HOT WATER SYSTEM MUST BE PROVIDED.

NOTE:

BRANCH PIPING TO ALL HEATERS MUST BE SAME SIZE AND LENGTH FOR EQUAL FLOW. THESE BRANCHES MAY BE SIZED UP TO 1 1/4" SO THAT CROSS SECTIONAL AREAS OF ALL INLETS AND OUTLETS AT LEAST EQUAL AREA OF THEIR RESPECTIVE MAIN PIPING.

COLD WATER SUPPLY (SIZED TO MEET APPLICATION AND CODE CONDITIONS) (SEE INSERT A & B)

FOUR HEATER WITH VERTICAL STORAGE TANK WITH OR WITHOUT BUILDING RECIRCULATION

INSTALL IN ACCORDANCE WITH ALL LOCAL CODES.

CAUTION: IF BUILDING COLD WATER SUPPLY HAS A BACK-FLOW PREVENTER, CHECK VALVE OR WATER METER WITH CHECK VALVE, PROVISIONS FOR THERMAL EXPANSION OF WATER IN THE HOT WATER SYSTEM MUST BE PROVIDED.

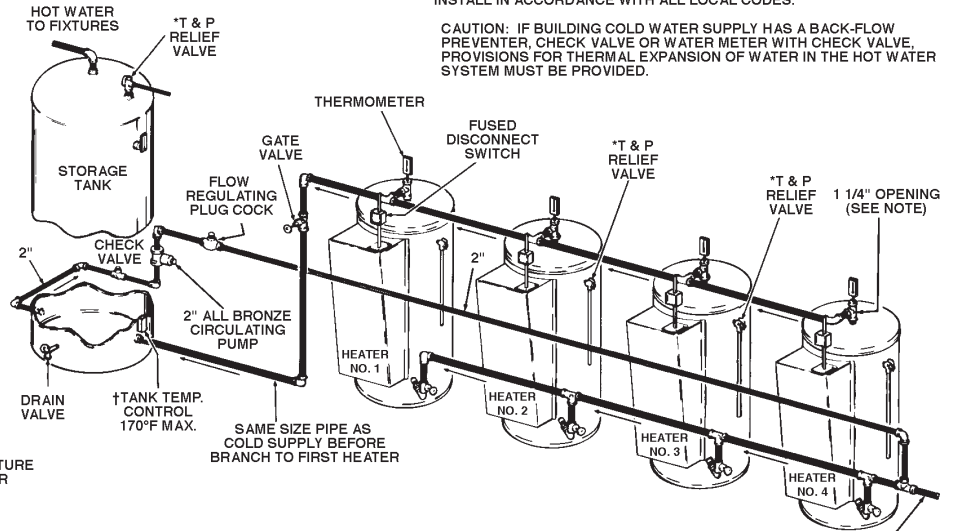

*PIPE RELIEF VALVE TO OPEN DRAIN

†TANK TEMPERATURE CONTROL SET AT DESIRED TEMPERATURE (MAX. 170°F). HEATER THERMOSTAT SET AT LEAST 5° HIGHER

CIRCULATING PUMP WIRING DIAGRAM

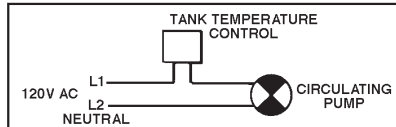

NOTE:

BRANCH PIPING TO ALL HEATERS MUST BE SAME SIZE AND LENGTH FOR EQUAL FLOW. THESE BRANCHES MAY BE SIZED UP TO 1 1/4" SO THAT CROSS SECTIONAL AREAS OF ALL INLETS AND OUTLETS AT LEAST EQUAL AREA OF THEIR RESPECTIVE MAIN PIPING.

REVERSE RETURN PIPING SHOWN



TEMPERATURE SETTING SHOULD NOT EXCEED SAFE TEMPERATURE AT FIXTURES. SEE WATER TEMPERATURE CONTROL WARNING ON PAGE 6. IF HIGHER PREHEAT TEMPERATURES ARE NECESSARY TO OBTAIN ADEQUATE BOOSTER OUTPUT, ADD AN ANTI-SCALD VALVE FOR HOT WATER SUPPLIED TO FIXTURES.

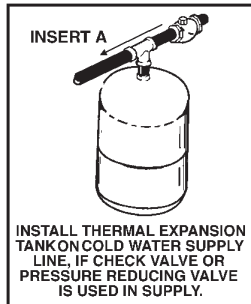

FOUR HEATER WITH HORIZONTAL STORAGE TANK WITH OR WITHOUT BUILDING RECIRCULATION

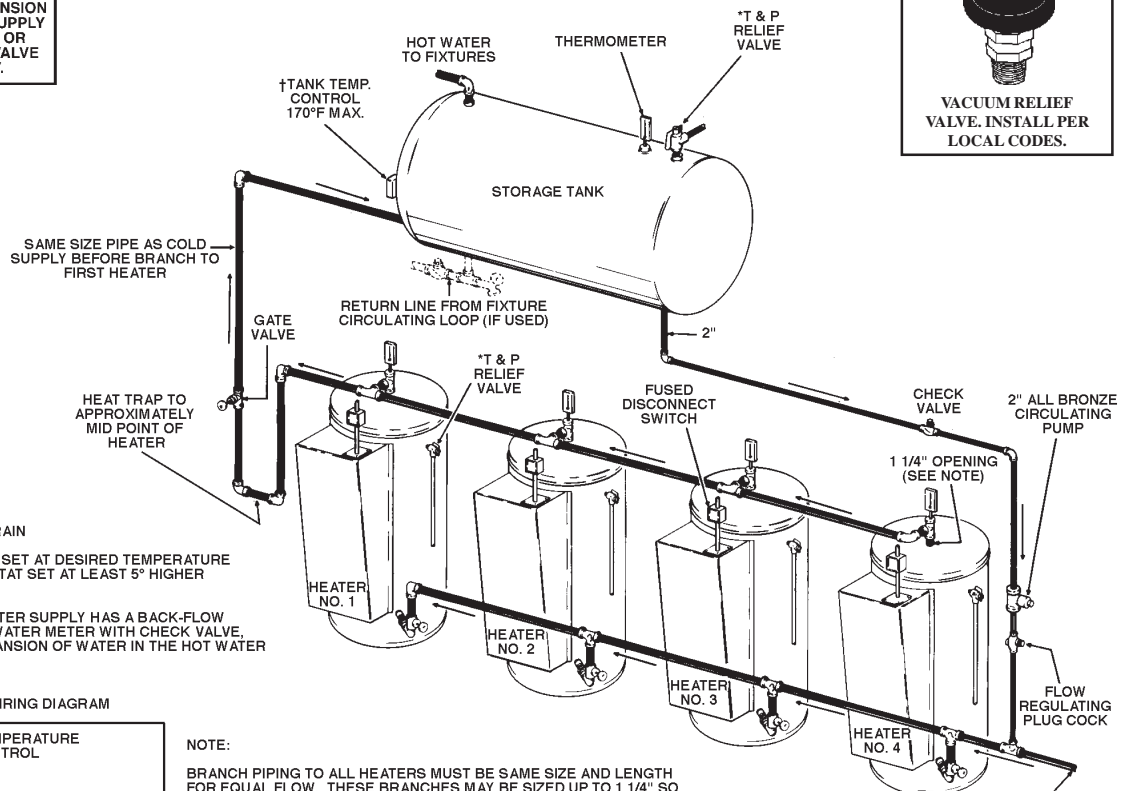
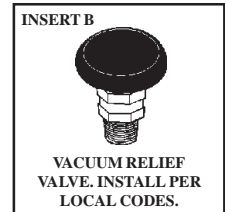

*PIPE RELIEF VALVE TO OPEN DRAIN

†TANK TEMPERATURE CONTROL SET AT DESIRED TEMPERATURE (MAX. 170°F). HEATER THERMOSTAT SET AT LEAST 5° HIGHER

CAUTION: IF BUILDING COLD WATER SUPPLY HAS A BACK-FLOW PREVENTER, CHECK VALVE OR WATER METER WITH CHECK VALVE, PROVISIONS FOR THERMAL EXPANSION OF WATER IN THE HOT WATER SYSTEM MUST BE PROVIDED.

CIRCULATING PUMP WIRING DIAGRAM

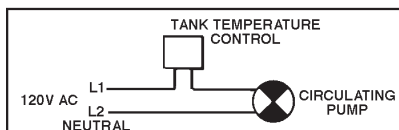

NOTE:

BRANCH PIPING TO ALL HEATERS MUST BE SAME SIZE AND LENGTH FOR EQUAL FLOW. THESE BRANCHES MAY BE SIZED UP TO 1 1/4" SO THAT CROSS SECTIONAL AREAS OF ALL INLETS AND OUTLETS AT LEAST EQUAL AREA OF THEIR RESPECTIVE MAIN PIPING.

REVERSE RETURN PIPING SHOWN

COLD WATER SUPPLY (SIZED TO MEET APPLICATION AND CONDITIONS) (SEE INSERT A & B)

MANIFOLD KITS

ALL DIMENSIONS IN INCHES.

TWO HEATERS

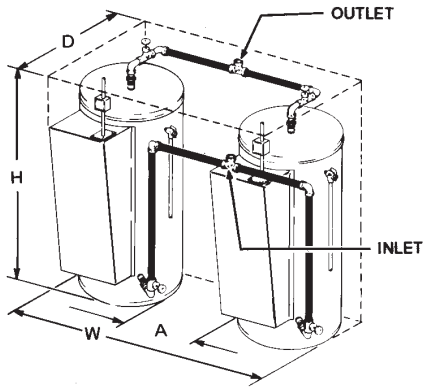

Model	Part Number	H	W	D	A
DRE/DVE-52	9003429	66 1/4	56 3/4	27 1/4	13 1/4
DRE/DVE-80	9003429	70 1/2	60 1/4	31 1/4	9 3/4
DRE/DVE-120	9003429	73 1/4	64 1/2	35 3/4	5 1/2

Inlet and outlet size — 1 1/2

THREE HEATERS

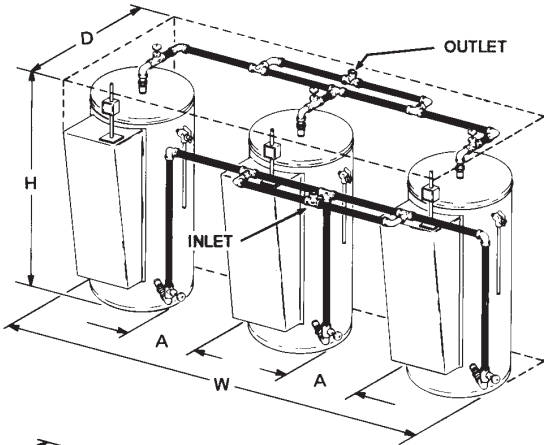

Model	Part Number	H	W	D	A
DRE/DVE-52	9003430	66 1/4	91 3/4	27 1/4	13 1/4
DRE/DVE-80	9003430	70 1/2	95 1/4	31 1/4	9 3/4
DRE/DVE-120	9003430	73 1/4	99 1/2	35 3/4	5 1/2

Inlet and outlet size — 2 1/2

FOUR HEATERS

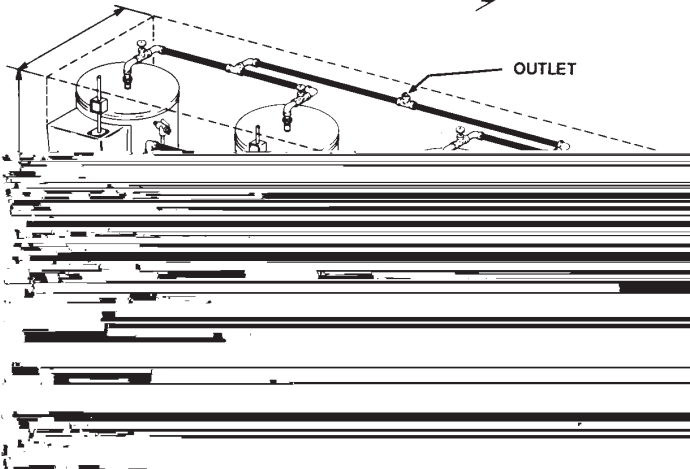

Model	Part Number	H	W	D	A
DRE/DVE-52	9003431	66 1/4	126 3/4	27 1/4	13 1/4
DRE/DVE-80	9003431	70 1/2	130 1/4	31 1/4	9 3/4
DRE/DVE-120	9003431	73 1/4	134 1/2	35 3/4	5 1/2

Inlet and outlet size — 2 1/2

Electrical

GENERAL

The installation must conform to these instructions, the local code authority having jurisdiction, and the requirements of the power company. In the absence of codes requirements follow the current version of NFPA-70. The National Electrical Code which may be ordered from National Fire Protection Association, 1 Batterymarch Park, Quincy, MA 02269.

WARNING

AN ELECTRICAL GROUND IS REQUIRED TO REDUCE RISK OF ELECTRIC SHOCK OR POSSIBLE ELECTROCUTION. The water heater should be connected to a separate grounded branch circuit with overcurrent protection and disconnect switch. The water heater should be grounded in accordance with national and local codes.

Check the heater model and rating plate information against the characteristics of the branch circuit electrical supply. **DO NOT CONNECT THE HEATER TO AN IMPROPER SOURCE OF ELECTRICITY.** Contact the heater supplier for conversion information if necessary.

Voltage applied to the heater should not vary more than +5% to -10% of the model and rating plate marking for satisfactory operation.

DO NOT ENERGIZE THE BRANCH CIRCUIT FOR ANY REASON BEFORE THE HEATER TANK IS FILLED WITH WATER. DOING SO WILL CAUSE THE HEATING ELEMENTS TO BURN OUT.

The branch circuit is connected to the heater wiring through an opening provided on the heater.

BRANCH CIRCUIT

The branch circuit wire and fuse size should be established through reference to the current version of the National Electrical Code or any other locally approved source in conjunction with the heater amperage rating. Branch circuit wires should have a temperature rating no less than 75°C. For convenience, portions of the wire size tables from the code are reproduced here. It is suggested the electrician size the branch circuit at 125% of the heater ampere rating and further increase wire size as necessary to compensate for voltage drop in long runs. Branch circuit voltage drop should not exceed 3% at the heater.

TABLE 310-16. Allowable Ampacities of Insulated Conductors
 Not more than three conductors in raceway, cable, or earth (directly buried), based on ambient temperature of 30°C (86°F)

Size	Temperature Rating of Conductor, See Table 310-13								Size
	60°C (140°F)	75°C (167°F)	85°C (185°F)	90°C (194°F)	60°C (140°F)	75°C (167°F)	85°C (185°F)	90°C (194°F)	
AWG MCM	TYPES RUW, T TW, UF	TYPES FEPW, RH, RHW, RUH, THW THWN, XHHW, USE, ZW	TYPES V, MI,	TYPES TA, TBS, SA, AVB, SIS, +FEP, +FEPB, +RHH, +THHN, +XHHW*	TYPES RUW, T TW, UF	TYPES RH, RHW, RUH, THW, THWN, XHHW, USE	TYPES V, MI,	TYPES TA, TBS, SA, AVB, SIS, +RHH, +THHN, +XHHW*	AWG MCM
COPPER					ALUMINUM OR COPPER-CLAD ALUMINUM				
18	21
16	22	22
14	15	15	25	25
12	20	20	30	30	15	15	25	25	12
10	30	30	40	40	25	25	30	30	10
8	40	45	50	50	30	40	40	40	8
6	55	65	70	70	40	50	55	55	6
4	70	85	90	90	55	65	70	70	4
3	80	100	105	105	65	75	80	80	3
2		115	120	120	75	90	95	95	2
1		130	140	140		100	110	110	1
0		150	155	155		120	125	125	0
00		175	185	185		135	145	145	00
000		200	210	210		1155	165	165	000
0000		230	235	285		180	185	185	0000
250		255	270	270		205	215	215	250
300		285	300	300		230	240	240	300
350		310	325	325		250	260	260	350
400		335	360	360		270	290	290	400
500		380	405	405		310	330	330	500
CORRECTION FACTORS									
Ambient Temp. °C	For ambient temperatures over 30°C, multiply the ampacities shown above by the appropriate correction factor to determine the maximum allowable load current.								Ambient Temp. °F
31-40	.82	.88	.90	.91	.82	.88	.90	.91	86-104
41-50	.58	.75	.80	.82	.58	.75	.80	.82	105-122
51-6058	.67	.7158	.67	.71	123-141
61-7035	.52	.5835	.52	.58	142-158
71-8030	.4130	.41	159-176

+The load current rating and the overcurrent protection for these conductors shall not exceed 15 amperes for 14 AWG, 20 amperes for 12 AWG, and 30 amperes for 10 AWG copper; or 15 amperes for 12 AWG and 25 amperes for 10 AWG aluminum and copper-clad aluminum.

*For dry locations only. See 75°C column for wet locations.

KW Input	Number of Elements	Element Wattage	Full Load Current in Amperes							No. of Thermostats	No. of Fuses
			Single Phase			Three Phase					
			208V	240V	277V	480V	208V	240V	480V		
6	3	2000	28.8	25.0	21.7	12.5	16.7	14.4	7.2	3	6
9		3000	43.3	37.5	32.5	18.8	25.0	21.7	10.8		
12		4000	57.7	50.0	43.3	25.0	33.3	28.9	14.4		
13.5		4500	64.9	56.3	48.7	28.1	37.5	32.5	16.2		
15		5000	72.1	62.5	54.2	31.3	41.6	36.1	18.0		
18	6	6000	---	75.0	65.0	37.5	---	43.3	21.7	6	12
18		3000	86.5	---	---	---	50.0	---	---		
24		4000	115.4	100.0	86.6	50.0	66.6	57.7	18.9		
27		4500	129.8	112.5	97.5	56.3	74.9	65.0	32.5		
30		5000	144.2	125.0	108.3	62.5	83.3	72.2	36.1		
36	9	6000	---	150.0	130.0	75.0	---	86.6	43.3	9	18*
36		4000	173.1	---	---	---	99.9	---	---		
40.5		4500	194.7	168.8	146.2	84.4	112.4	108.3	54.1		
45		5000	216.3	187.5	162.5	93.8	124.9	108.3	54.1		
54		6000	---	225.0	194.9	112.5	149.9	129.9	65.0		

AMPERAGE TABLE/OVERCURRENT PROTECTION

The table above provides the total connected heating element load in amperes for branch circuit conductor and overcurrent protection sizing. Single-phase heaters are two wire circuits. Three-phase heaters are three wire circuits. In addition to the foregoing, a grounded conductor is required.

The rating of the overcurrent protection must be computed on the basis of 125% of the total connected load amperage. Where the standard ratings and settings do not correspond with this computation, the next higher standard rating or setting should be selected.

HEATER CIRCUITS - DVE MODELS

The water heater's electrical components are pictured and identified on page 2. The model and rating plate illustration on page 4 identifies heater circuit ratings. The DVE model has two electrical circuits.

- The control circuit, where the thermostat directly operates the contactor coils.
- The power circuit, which is operated by the control circuit carries the electrical load of the heating elements.

The following describes the heater circuits and includes wiring diagrams. All heater circuits are designed for 50/60 cycle alternating current.

CONTROL CIRCUIT - DVE MODELS

The heater is equipped with one of the following 120V control circuits, resulting in:

- Simultaneous element operation where all of the heating elements are operated by one thermostat. This is the standard circuit and may be used with up to nine elements.
- Sequenced element operation where each row of three elements are operated by its own thermostat. This is an optional circuit and may be used with six or nine elements.

The control circuit is operated on single-phase 120V current obtained from the control transformer or as shown in the wiring diagram.

Beginning at the fuse block, control circuit wiring is 14 Awg, AWM (Appliance wiring material) type, rated 600 volts, 105°C.

Standard equipment includes control circuit fusing using two, 3 amp, class G fuses with 600 volt rating. Do not substitute fuses of a different rating.

TRANSFORMER CONNECTION TABLES

NOTE: THIS TABLE TO BE USED FOR 8 TAP AND 5 TAP TRANSFORMERS

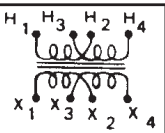
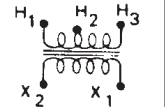
	VOLTS	LINE ON	LOAD ON	CONNECT
	480	H ₁ & H ₄	X ₁ & X ₄	H ₂ & H ₃
	480/277			X ₁ & X ₃ X ₂ & X ₄
	208	H ₁ & H ₂	X ₁ & X ₂	—
	240	H ₁ & H ₃	X ₁ & X ₂	—

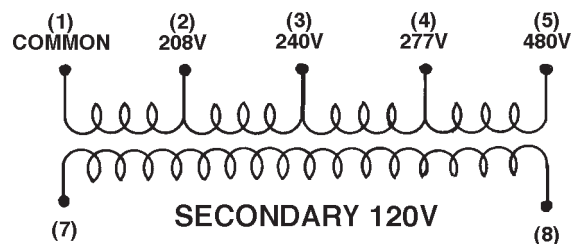

VOLTS	LINE ON	LOAD ON
208	COMMON & 208	SECONDARY 120V
240	COMMON & 240	
277	COMMON & 277	
480	COMMON & 480	

DVE CONTROL CIRCUIT DIAGRAMS

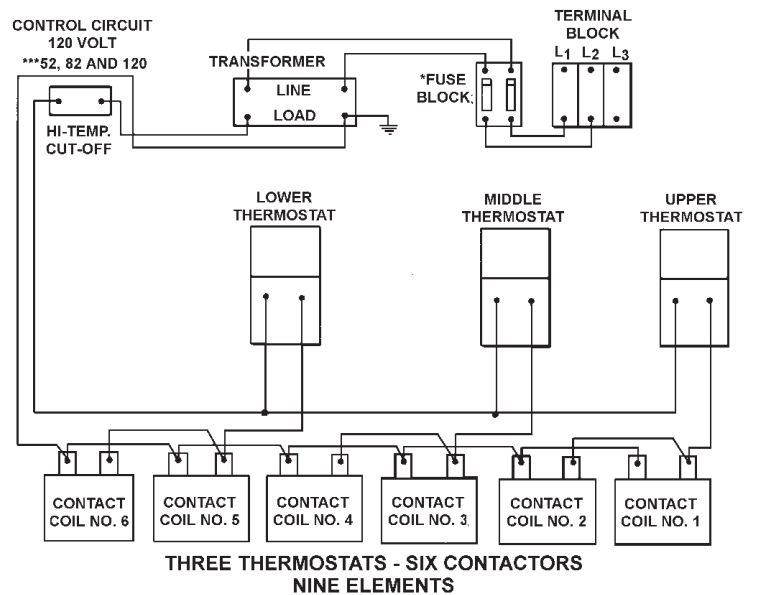
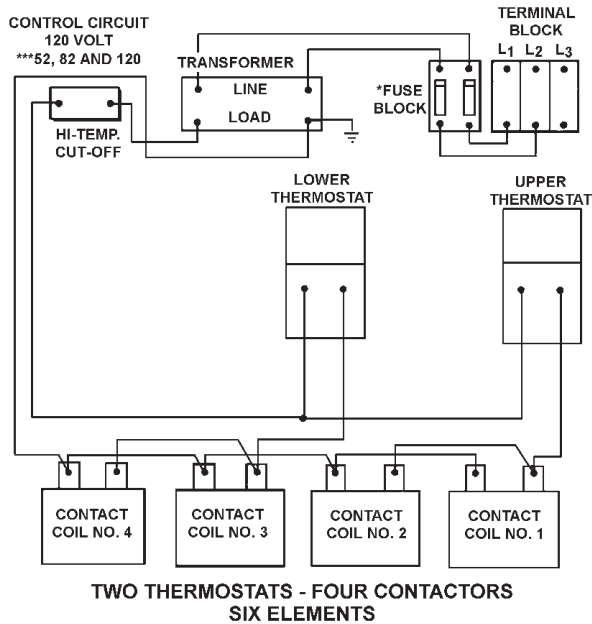
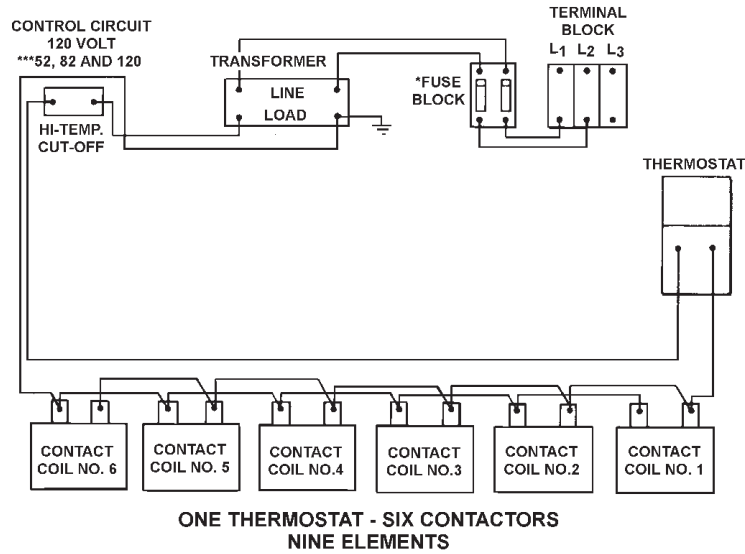
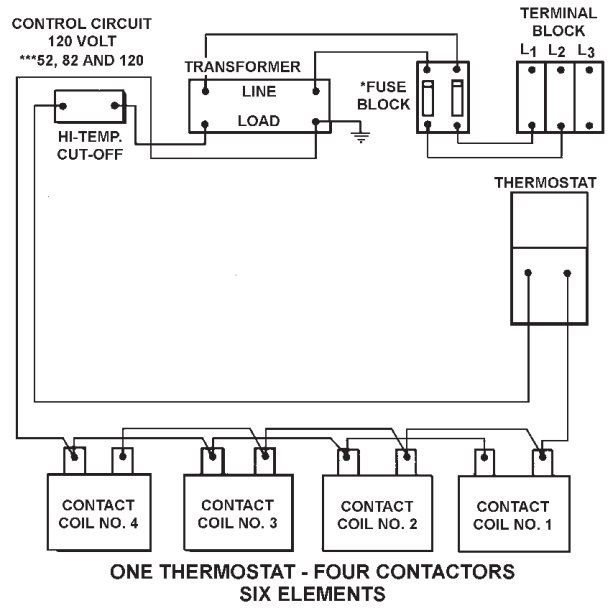
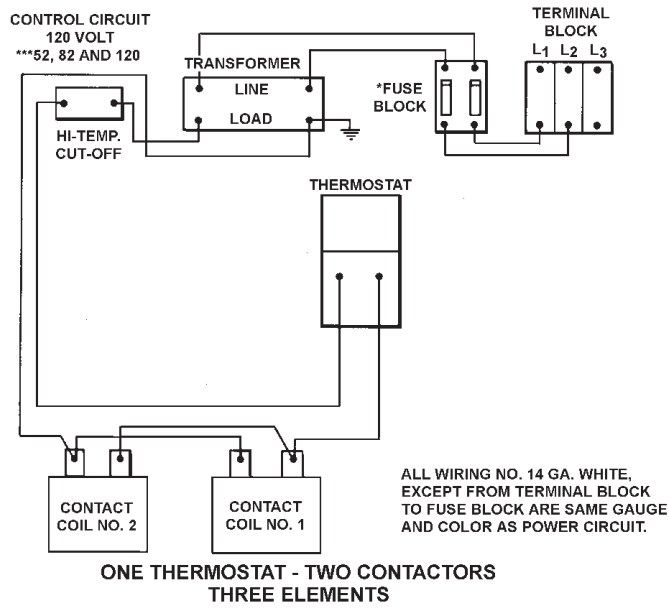

* USE ONLY 3 AMP, CLASS G FUSES AS CONTROL CIRCUIT ON IMMERSION THERMOSTAT MODELS

DVE POWER CIRCUIT DIAGRAMS

POWER CIRCUIT

The power circuit wiring is 12 Awg. AWM or TEW type, rated 600 volts, 105°C.

Power circuit fusing consists of three 30 amp class G fuses for each contactor. See wiring diagrams. Do not substitute fuses of a different rating.

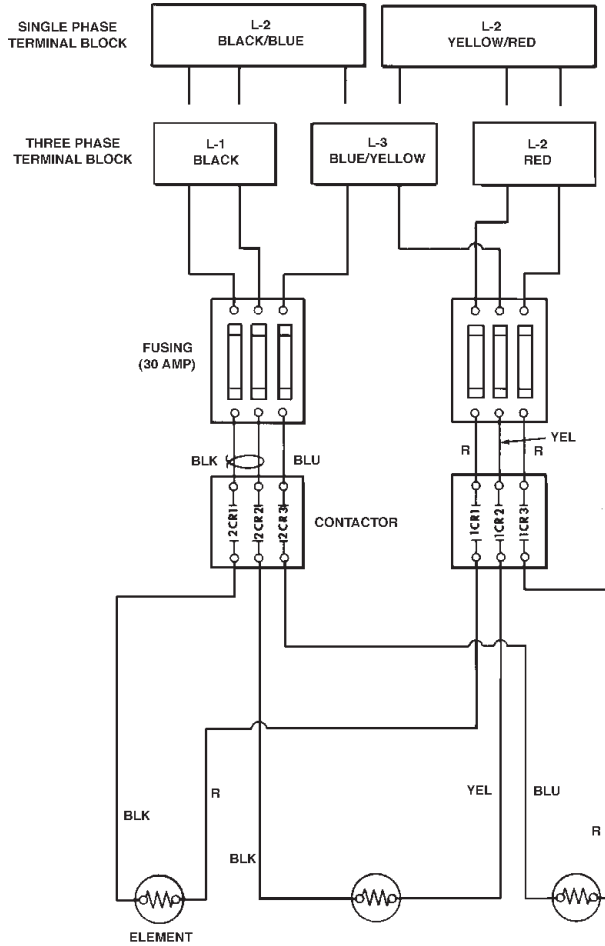

THREE ELEMENTS - SINGLE AND THREE PHASE

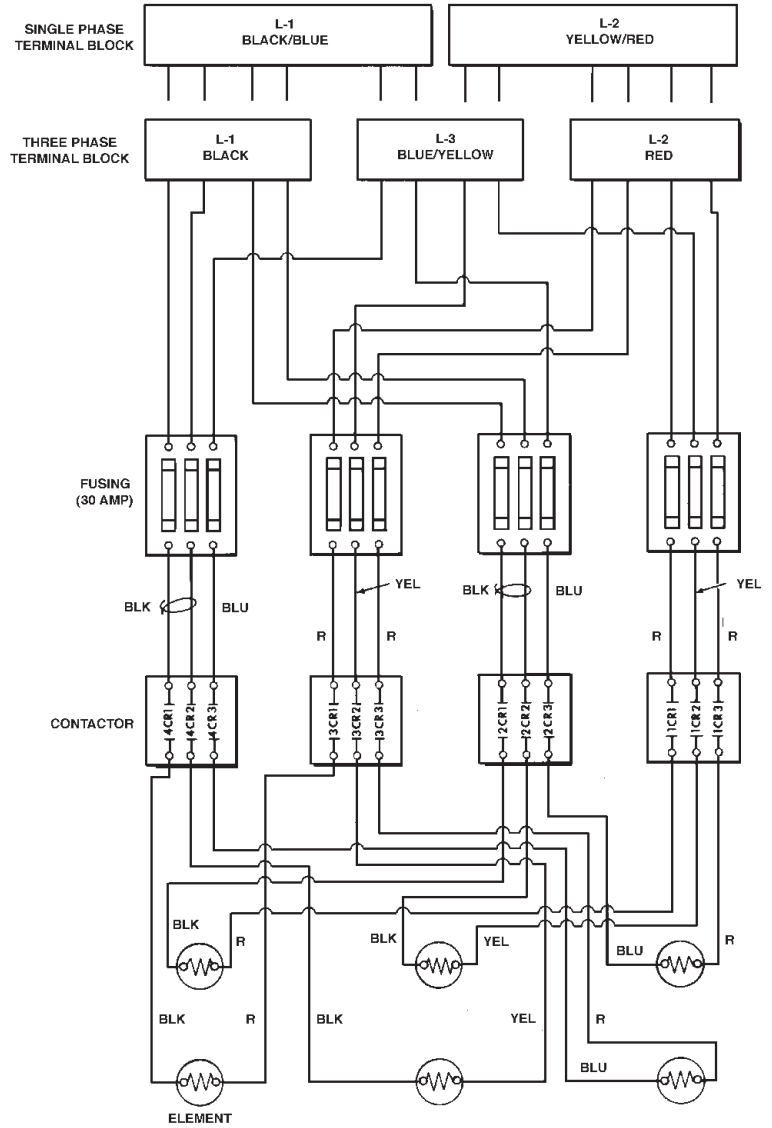

SIX ELEMENTS - SINGLE AND THREE PHASE

DVE POWER CIRCUIT DIAGRAMS (Continued)

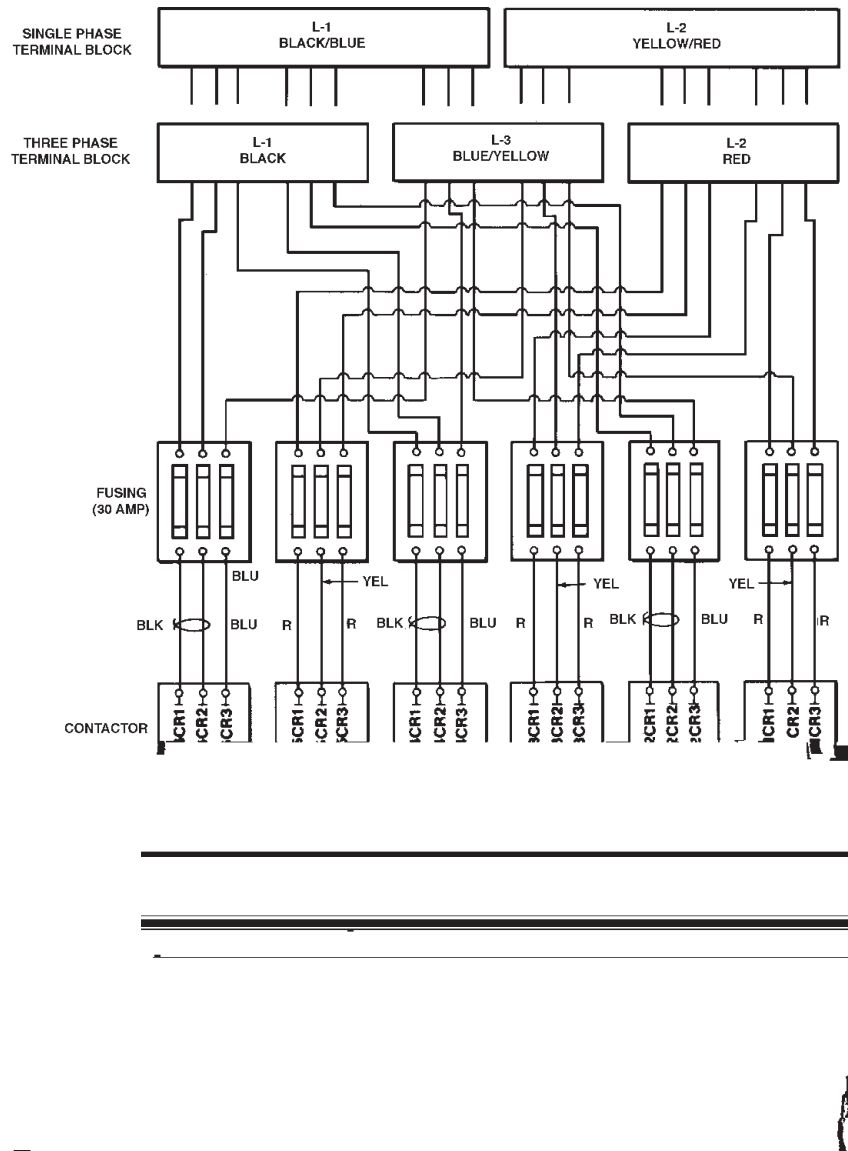

NINE ELEMENTS - SINGLE AND THREE PHASE

CONVERSION TO SINGLE PHASE

When the heater is shipped for connection to a three-phase electrical service, it may be connected to a single-phase electrical service of the same voltage by:

1. Disconnect blue wires and yellow wires from terminal L3.
2. Reconnect all blue wires to terminal L1 (with black wires).
3. Reconnect all yellow wires to terminal L2 (with red wires).
4. Connect incoming power to terminals L1 and L2.

CONVERSION TO THREE PHASE

When heater is shipped for connection to a single-phase electrical service, it may be connected to a three-phase electrical service of the same voltage by:

1. Disconnect blue wires from terminal L1.
2. Disconnect yellow wires from terminal L2.
3. Reconnect all blue wires and yellow wires to terminal L3.
4. Connect incoming power to terminals L1, L2, and L3.

DRE POWER CIRCUIT DIAGRAMS

HEATER CIRCUITS—DRE MODELS

The water heater's electrical components are pictured and identified on page 2.

The following describes the heater circuits and includes wiring diagrams. All heater circuits are designed for 60/50 hertz alternating current.

The DRE circuit wiring is 12 AWG, AWM, or TEW type, rated 600 volts, 105°C.

FUSING

Fusing consists of two 30 amp class G fuses for each element. See wiring diagrams. Do not substitute fuses of a different rating.

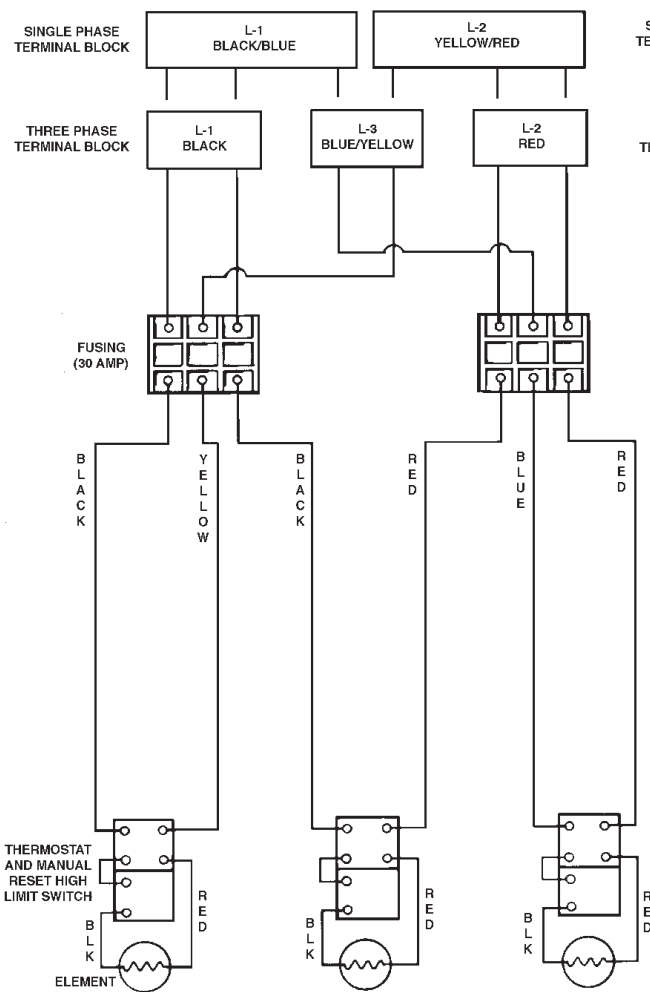

THREE ELEMENTS - SINGLE AND THREE PHASE

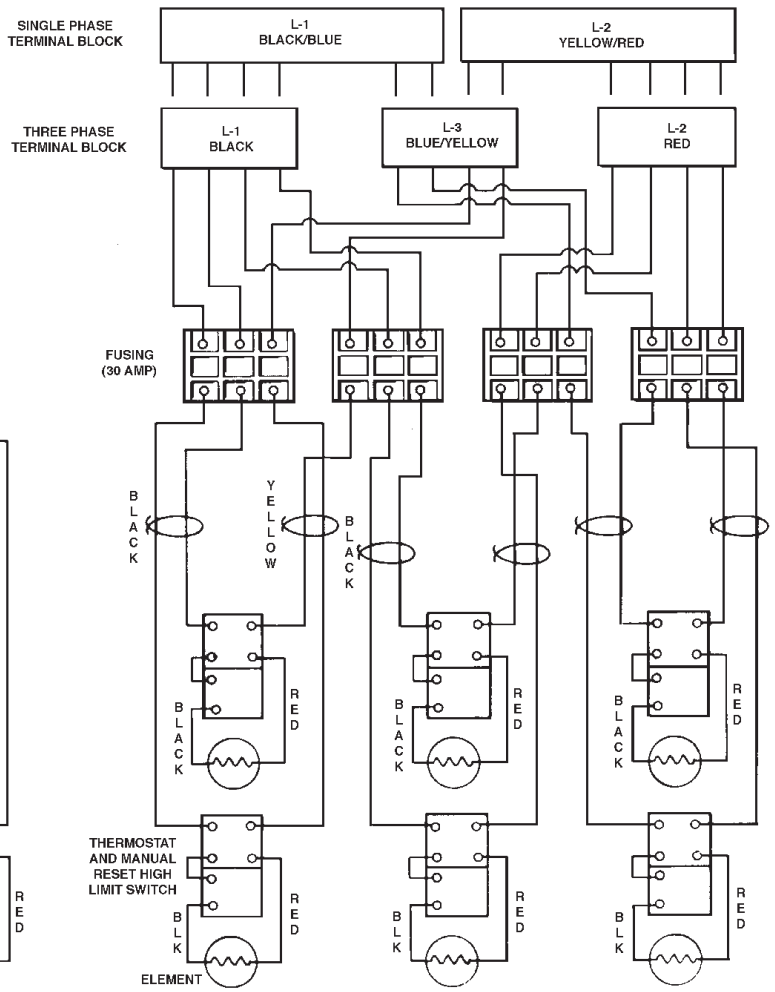

SIX ELEMENTS - SINGLE AND THREE PHASE

DRE POWER CIRCUIT DIAGRAMS

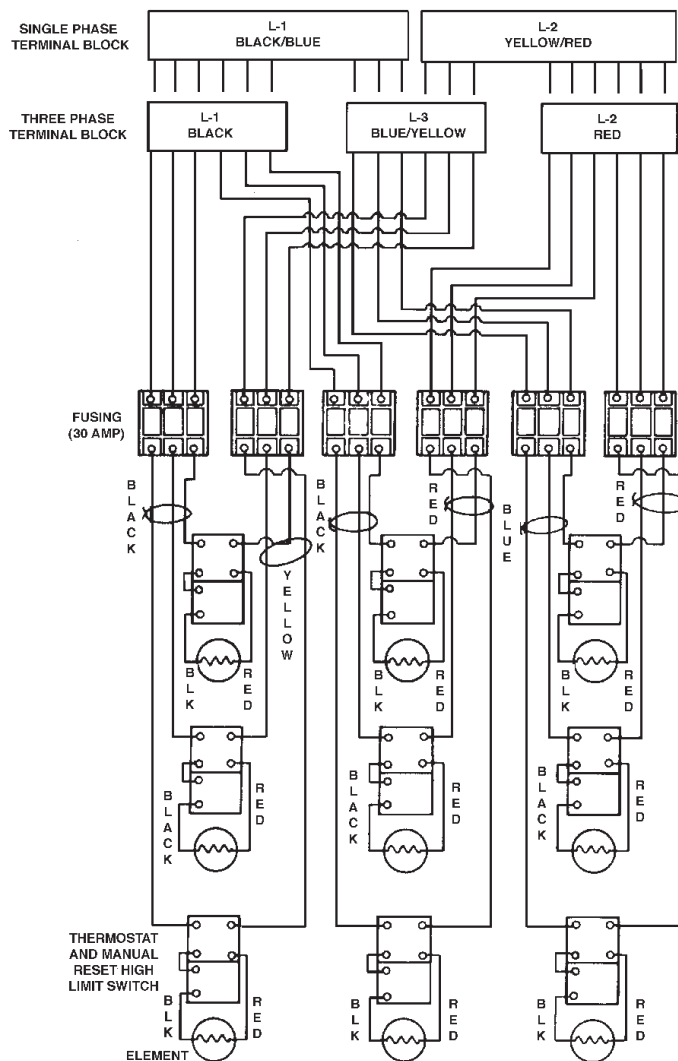

NINE ELEMENTS - SINGLE AND THREE PHASE

CONVERSION TO SINGLE PHASE

When the heater is shipped for connection to a three-phase electrical service, it may be connected to a single-phase electrical service of the same voltage by:

1. Disconnect blue wires and yellow wires from terminal L3.
2. Reconnect all blue wires to terminal L1 (with black wires).
3. Reconnect all yellow wires to terminal L2 (with red wires).
4. Connect incoming power to terminals L1 and L2.

CONVERSION TO THREE PHASE

When heater is shipped for connection to a single-phase electrical service, it may be connected to a three-phase electrical service of the same voltage by:

1. Disconnect blue wires from terminal L1.
2. Disconnect yellow wires from terminal L2.
3. Reconnect all blue wires and yellow wires to terminal L3.
4. Connect incoming power to terminals L1, L2, and L3.

Operation

GENERAL

Never turn on power to the water heater without being certain the water heater is filled with water, and a temperature and pressure relief valve is installed in the relief valve opening.

DO NOT TEST ELECTRICAL SYSTEM BEFORE HEATER IS FILLED WITH WATER. FOLLOW FILLING AND START-UP INSTRUCTIONS IN OPERATION SECTION.

FILLING

1. Turn off the electrical disconnect switch.
2. Close the water heater drain valve by turning hand wheel to right (clockwise).
3. Open a nearby hot water faucet to permit the air in the system to escape.
4. Fully open the cold water inlet pipe valve allowing the heater and piping to be filled.
5. Close the hot water faucet as water starts to flow. The heater is now ready for STARTUP and TEMPERATURE REGULATION.

STARTUP

The following checks should be made by the installer when the heater is placed into operation for the first time.

1. Turn off the electrical disconnect switch.
 2. Open the front panel, check all water and electrical connections for tightness. Also check connections on top and side of heater.
- Repair water leaks and tighten electrical connections as necessary.
3. Depress red button on manual reset high limit switches.
 4. Turn on the electrical disconnect switch.
 5. Observe the operation of the electrical components during the first heating cycle. Use care as the electrical circuits are energized.

- Thermostat operation may be checked by (a) manually operating thermostat(s) and (b) allowing the heater to come up to temperature and shut off automatically.
6. Close the front panel.

HIGH TEMPERATURE LIMITING DEVICE

The heater control circuit contains a high temperature cutoff switch. This device automatically shuts off the heating elements if excessive water temperatures, near the steam point, are reached. The high temperature cutoff contacts open at 190°F and must be manually reset (after a 30°F drop in water temperature).

DRAINING

The water heater must be drained if it is to be shut down and exposed to freezing temperatures. Maintenance and service procedures may also require draining the heater.

1. Turn off the electrical disconnect switch.
 2. Close the supply water inlet valve to heater.
 3. Attach hose to outlet opening of drain valve and direct end to drain.
 4. Open a nearby hot water faucet and the heater drain valve.
 5. If the heater is being drained for an extended shutdown, it is suggested the drain valve be left open during this period. The hose may be removed.
- Follow FILLING instructions when restoring hot water service.

CIRCULATING PUMP

Where the water heating system includes a field installed circulating pump, it must be lubricated before being operated. The tube of lubricant supplied with the pump includes directions for use.

The circulating pump should be of all bronze construction.

Maintenance

GENERAL

Periodically the drain valve should be opened and the water allowed to run until it flows clean. This will help to prevent sediment buildup in the tank bottom.

Periodically check the temperature and pressure relief valve to ensure that it is in operating condition. Lift the lever at the top of the valve several times until the valve seats properly and operates freely.



THE WATER PASSING OUT OF THE VALVE DURING THIS CHECKING OPERATION MAY BE EXTREMELY HOT.

Water heater maintenance includes periodic tank flushing and cleaning, and removal of lime scale from the heating element.

The heater tank is equipped with an anode rod to aid in corrosion control.

Anode inspection must be performed periodically based on experience (or at least annually) to check the rod diameter and determine if replacement is necessary. The anode is initially about 13/16" to 7/8" diameter with an approximate 1/8" diameter wire in the center of the rod. The anode should be replaced when the 1/8" diameter wire is visible as it has been expended in the control of corrosion. Your dealer should be contacted for anode inspection.

MAINTENANCE SCHEDULE			
Component	Operation	Interval	Required
Tank	Flushing	Periodically	
Elements	Lime Scale Removal	As needed	UN•Lime [®] delimer & element gaskets, Part
Anode	Inspect	As needed	

Tank flushing should be performed in accordance with the above schedule. Tank sediment removal and element lime scale removal must be performed as needed as determined by periodic inspection. Following are the instructions for performing recommended maintenance.

FLUSHING

The water heater drain valve should be opened periodically to help prevent sediment buildup on the tank bottom.

1. Turn off the electrical disconnect switch.
2. Attach hose to outlet opening of drain valve and direct end to drain.
 - Open the drain valve by turning the hand wheel to the left (counterclockwise). Allow water to flow until it runs clean.
 - If water does not flow from opened drain valve, follow instructions for sediment removal.
3. When finished flushing:
 - Close heater drain valve and remove hose.
 - Turn on electricity.

SEDIMENT REMOVAL

Water borne impurities consist of fine particles of soil and sand which settle out and form a layer of sediment on the bottom of the tank. In time, if not removed, the level of sediment might reach the heating elements and cause their failure.

For convenience, sediment removal and element lime scale removal should be performed at the same time as follows.

LIME SCALE REMOVAL

Lime scale accumulations on the heating elements is a normal condition, common to all immersion type elements. Factors which affect the amounts of this formation are:

1. Amount of hot water used. As the volume of water heated increases, more scale results.
2. Water temperature. As the temperature of the water is increased, more scale is deposited on the elements.
3. Characteristics of water supply.

Regardless of water treatment, the elements should be examined regularly.

Lime scale accumulations may cause noises to occur during operation.

It is recommended that a heating element be removed periodically for examination. If it is scaled, all of the elements should be removed and cleaned. If the tank bottom has an accumulation of sediment it should be cleaned.

Lime scale should be removed by dissolving the accumulation in UN•LIME[®] delimer. UN•LIME is a non-muriatic delimer, available from Product Service Division, A.O. Smith Water Heater Parts Fulfillment, 125 Southeast Parkway, Franklin, TN 37068. Do not use muriatic or hydrochloric acid base deliming solutions to remove lime scale from the elements.

Replacement gaskets, part no. 9000308, should be available at this time.

1. Turn off electrical disconnect switch.
2. Drain the heater following DRAINING instructions.
3. Open front panel.
4. Disconnect the element wiring. Try not to disturb the wiring unnecessarily and reconnection will be easier.
5. Unscrew each element.
6. Remove the elements and gaskets from the openings.
 - Use a twisting, pulling action to remove elements scaled beyond the size of the tank openings.
 - Brush loose scale from elements.
7. Lime scale removal:
 - Place limed ends of heating elements into UN•LIME delimer and allow scale to dissolve. Do not permit delimer or water to contact heating element electrical terminals.

Other scale removal:

- Silicates, sulfates, and aluminates must be removed by scraping or other mechanical means. Lime scale dissolvents will not remove these types of scale which are occasionally encountered.
8. Flush cleaned ends of elements with water when deliming or cleaning is completed.
 9. Remove sediment and scale from the tank bottom through the access provided by the element openings or drain valve opening.
 - The cold water inlet valve and drain valve may be opened to aid the cleanout process.
 10. Clean remaining gasket material from tank and element flanges. Do not reuse original element gaskets.
 11. Put new gaskets on each element and install into tank openings.
 - Uniformly tighten element bolts. Torque to approximately 32 ft./lbs.

12. Attach element wires to connection points from which they were removed.
13. Follow FILLING instructions to restore hot water service.
 - Check for water leaks around elements and proper operation when heater is filled.
 - Close the front panel.
2. Some of the electrical components of the water heater make sounds which are normal.
 - Contactors will "click" or snap as the heater starts and stops.
 - Transformers and contacts often hum.

Water leakage is suspected

Refer to Leakage Checkpoint of following page.

1. Check to see if the heater drain valve is tightly closed.
2. If the outlet of the relief valve is leaking it may represent:
 - Excessive water temperature.
 - Faulty relief valve.
 - Excessive water pressure.
3. Excessive water pressure is the most common cause of relief valve leakage. It is often caused by a "closed system." A check valve in the inlet system will not permit the expanded hot water volume to equalize pressure with the main. A relief valve must release this water or the water heater or plumbing system will be damaged.

When such a condition is encountered, local codes or inspection agency should be consulted to determine which system is acceptable in your area. These may consist of:

- Installation of a second relief valve set lower than the primary safety relief valve.
 - An expansion tank of suitable pressure and provision to avoid water logging.
 - Removal of the check valve.
4. Examine the area around the element for gasket leakage.
 - Tighten the elements or, if necessary, follow the WATER AND LIME SCALE REMOVAL procedure to replace the gaskets.

IF YOU CANNOT IDENTIFY OR CORRECT THE SOURCE OF MALFUNCTION

1. Place the water heater electrical switch in the OFF position.
2. Close the supply water inlet valve to the heater.
3. Contact your dealer.

REPLACEMENT PARTS

Replacement parts may be ordered through dealers, authorized servicers, or distributors. Refer to Yellow Pages for where to call or contact the Product Service Division, A.O. Smith Water Heater Parts Fulfillment, 125 Southeast Parkway, Franklin, TN 37068, 1-800-433-2545. When ordering parts, specify complete model no., serial no., (see rating plate), quantity and name of part desired. Standard hardware items should be purchased locally.

CHECKLIST

Before calling for service, check the following points to see if the cause of trouble can be identified and corrected.

Reviewing this checklist may eliminate the need of a service call and quickly restore hot water service. The illustration on page 2 identifies the location of all of the heater components.

BE SURE TO TURN OFF THE ELECTRICITY WHEN CHECKING EQUIPMENT.

Not enough or no hot water

1. Be certain the electrical disconnect switch serving the water heater is in the ON position.
2. Check the fuses.
 - The electrical disconnect switch usually contains fuses.
 - The heater has fusing.
3. If the water was excessively hot, and is now cold, the high limit switch may have operated.
 - To reset, open the front panel and push the reset button.
 - Repeated operation of the high temperature cutoff should be investigated by your dealer.
4. The capacity of the heater may have been exceeded by a large demand for hot water.
 - Large demands require a recovery period to restore water temperature.
5. Cooler incoming water temperature will lengthen the time required to heat water to the desired temperature.
6. Look for hot water leakage.
7. Sediment or pipe scale may be affecting water heater operation. Refer to page 23 for details.

Water is too hot

1. Sediment or lime scale accumulations on the elements causes sizzling and hissing noises when the heater is operating.
 - The sounds are normal, however, the tank bottom and elements should be cleaned. Refer to page 23 for details.

Leakage Checkpoints

INSTRUCTIONS: USE THIS ILLUSTRATION AS A GUIDE WHEN CHECKING FOR SOURCES OF WATER LEAKAGE. YOU OR YOUR DEALER MAY BE ABLE TO CORRECT WHAT APPEARS TO BE A PROBLEM.

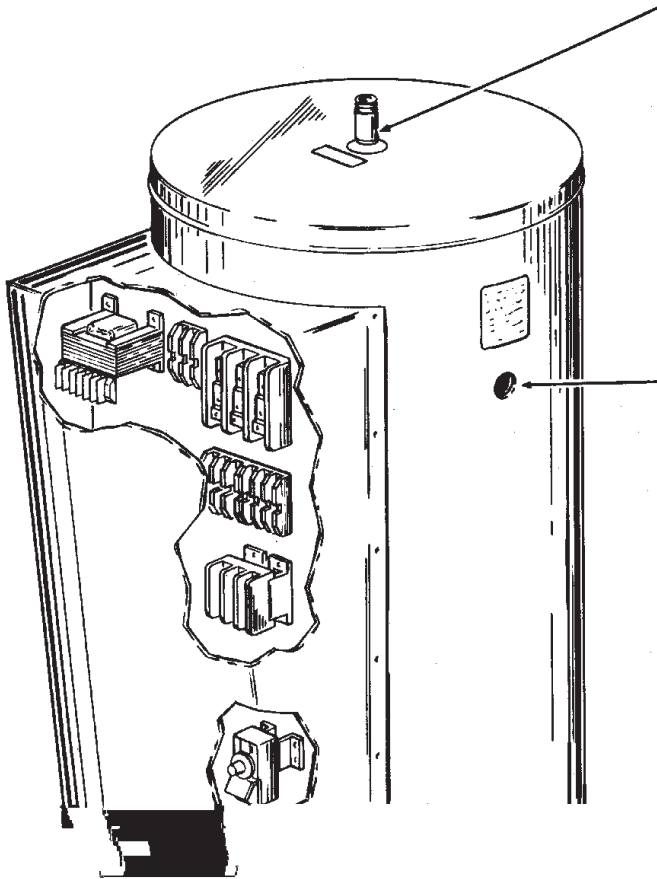

Where possible, remove or lift top cover to examine threads of fittings installed into tank for evidence of leakage. Correct fitting leaks as necessary.

Relief valve operation and leakage may be due to water expansion during heating cycle or foreign material on seat of valve. If the valve is not piped to an open drain, the released water could be mistaken for a leaking heater. To check where threaded portion enters tank, insert Q-tip or similar absorbent material between jacket opening and valve to swab spud area. Remove valve* if leak is indicated and repair with pipe joint compound.

Water on the side of the tank may be condensation due to the panel or insulation not being in place.

Water leaks at the elements may be due to:

1. Defective elements which leak at terminals or through flange. Replace element*.



Element/gasket leak:

Tighten element with element wrench. If leak persists, remove element* and discard gasket. Clean gasket seating areas and re-install element with new gasket.

Condensation and dripping may appear on pipes when inlet water temperature is low. Pipe fitting may be leaking.

Drain valve leakage could be from the valve itself. Either correct the problem or replace the valve*. To check for leakage where threaded portion enters tank, insert Q-tip or similar absorbent material between jacket opening and valve to swab spud area. Remove valve* if leak is indicated and repair with pipe joint compound.

All water which appears at the heater bottom or on the surrounding floor may be caused by condensation, loose connections or relief valve operation and leakage. Do not replace the heater until a full inspection of all potential leak points is made and corrective steps taken to stop the leak. Leakage from other appliances, water lines, or ground seepage should also be suspected until proved otherwise.

* Contact your dealer as it is necessary to shut off electricity and drain tank to perform procedure.

Limited Warranty

A. O. Smith Corporation, the warrantor, extends the following LIMITED WARRANTY to the owner of this water heater:

1. THE TANK

If the glass-lined tank in this water heater shall prove upon examination by the warrantor to have leaked due to natural corrosion from potable water therein, during the first THREE years after initial installation, the warrantor will supply a complete new A. O. Smith water heater of equivalent size and current model. Some government agencies are requiring energy efficient standards for water heaters. In the event regulations prohibit sale of a model of equivalent size and construction, A. O. Smith will provide a model which complies with the regulations of your area, in which case the consumer will be charged the difference in price between the like replacement and the energy efficient model required. The warranty on the replacement water heater will be limited to the unexpired term of the original warranty.

2. ALL OTHER PARTS

If within ONE year after initial installation of this water heater, any part or portion shall prove upon examination by the warrantor to be defective in material or workmanship, the warrantor will repair or replace such part or portion at its option.

3. CONDITIONS and EXCEPTIONS

This warranty shall apply only when the water heater is installed in accordance with local plumbing and building codes, ordinances and regulations, the printed instructions provided with it and good industry practices. In addition, a temperature and pressure relief valve, certified by A.G.A. and approved by the American Society of Mechanical Engineers, must have been installed.

a. This warranty shall apply only when the heater is used:

- (1) at temperatures not exceeding the maximum setting of its thermostat;
- (2) at water pressure not exceeding the working pressure shown on the water heater;
- (3) when filled with potable water, free to circulate at all times;
- (4) in a noncorrosive and non-contaminated atmosphere;
- (5) in the United States, its territories or possessions, and Canada.
- (6) used with factory approved anode(s) installed;
- (7) in its original installation location;
- (8) sized in accordance with proper sizing techniques for commercial water heaters;
- (9) bearing a rating plate which has not been altered, defaced or removed except as required by the warrantor;
- (10) not used in a closed system without a properly sized and installed thermal expansion tank;
- (11) fired at the proper voltage and wattage;
- (12) maintained in accordance with the instructions printed in the manual included with the heater.

b. Any accident to the water heater, any misuse, abuse (including freezing) or alteration of it, any operation of it in a modified form, or any attempt to repair tank leaks will void this warranty.

4. SERVICE and REPAIR EXPENSE

Under this limited warranty the warrantor will provide only a replacement water heater or part thereof. The owner is responsible for all other costs. Such costs may include but are not limited to:

- a. Labor charges for service, removal, repair, or reinstallation of the water heater or any component part;
- b. Shipping, delivery, handling, and administrative charges for forwarding the new heater or replacement part from the nearest distributor and returning the claimed defective heater or part to such distributor;
- c. All cost necessary or incidental for any materials and/or permits required for installation of the replacement heater or part.

5. LIMITATIONS ON IMPLIED WARRANTIES

Implied warranties, including any warranty of merchantability imposed on the sale of this heater under state law are limited to one (1) year duration for the heater or any of its parts. Some states do not allow limitations on how long an implied warranty lasts, so the above limitation may not apply to you.

6. CLAIM PROCEDURE

Any claim under this warranty should be initiated with the dealer who sold the heater, or with any other dealer handling the warrantor's products. If this is not practicable, the owner should contact:

U.S. Customers
A. O. Smith Water Products Company
500 Tennessee Waltz Parkway
Ashland City, TN 37015
Telephone: 1-800-323-2636

Canadian Customers
A. O. Smith Enterprises, Ltd.
P. O. Box 310 - 768 Erie Street
Stratford, Ontario N5A 6T3
Telephone: 1-800-265-8520

- a. The warrantor will only honor replacement with identical or similar water heater or parts thereof which are manufactured or distributed by the warrantor.
- b. Dealer replacements are made subject to in-warranty validation by warrantor.

7. DISCLAIMERS

NO OTHER EXPRESS WARRANTY HAS BEEN OR WILL BE MADE IN BEHALF OF THE WARRANTOR WITH RESPECT TO THE MERCHANTABILITY OF THE HEATER OR THE INSTALLATION, OPERATION, REPAIR, OR REPLACEMENT OF THE HEATER. THE WARRANTOR SHALL NOT BE RESPONSIBLE FOR WATER DAMAGE, LOSS OF USE OF THE UNIT, INCONVENIENCE, LOSS OR DAMAGE TO PERSONAL PROPERTY, OR OTHER CONSEQUENTIAL DAMAGE. THE WARRANTOR SHALL NOT BE LIABLE BY VIRTUE OF THIS WARRANTY OR OTHERWISE FOR DAMAGE TO ANY PERSONS OR PROPERTY, WHETHER DIRECT OR INDIRECT, AND WHETHER ARISING IN CONTRACT OR IN TORT.

- a. Some states do not allow the exclusion or limitation of the incidental or consequential damage, so the above limitation or exclusion may not apply to you.
- b. This warranty gives you specific legal rights, and you may also have other rights which vary from state to state.

Fill in the following for your own reference. Keep it. Registration is not a condition of warranty. The model and serial number are found on the heater's rating plate.

Model No. _____ Serial No. _____ Date Installed _____

Dealer's Name _____

Dealer's Address _____ Phone No. _____

City and State _____ Zip _____

A.O. Smith
Water Heaters

McBee, South Carolina 29101
Phone: 1-800-527-1953 Fax: 800-433-2515
www.hotwater.com e-mail: parts@hotwater.com