

MODELS DEN AND DEL

COMMERCIAL ELECTRIC WATER HEATERS

- Installation
- Operation
- Electrical
- Maintenance
- Wiring Diagrams
- Leakage Checkpoints
- Replacement Parts
- Limited Warranty



A.O. Smith **Water Heaters**

A DIVISION OF A. O. SMITH CORPORATION
McBee, South Carolina, USA
www.hotwater.com



**TEXT PRINTED OR OUTLINED IN RED CONTAINS INFORMATION RELATIVE TO YOUR SAFETY.
PLEASE READ THOROUGHLY BEFORE INSTALLING AND USING THIS APPLIANCE.**

PLACE THESE INSTRUCTIONS ADJACENT TO HEATER AND NOTIFY OWNER TO KEEP FOR FUTURE REFERENCE.

ROUGH-IN DIMENSIONS

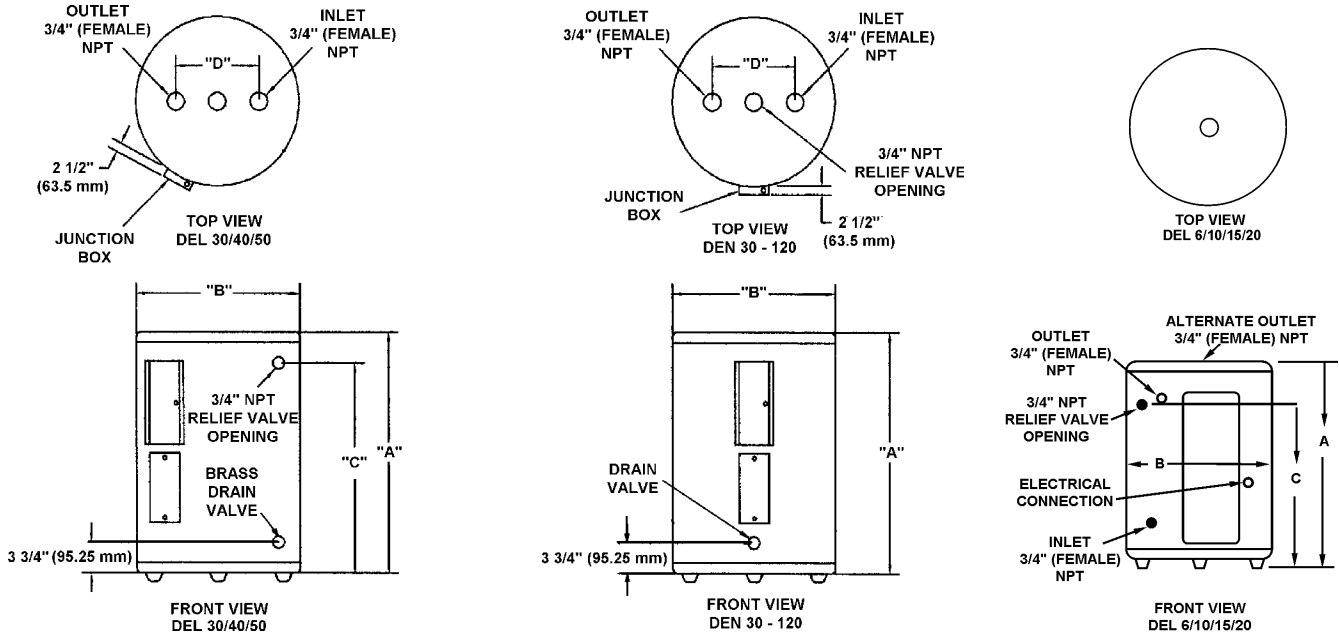

ROUGH-IN DIMENSIONS

Models Dimensions	No. of Elements	Tank Capacity		A		B		C		D		Approx. Shipping Weight.	
		US Gals.	Litres	inches	mm	inches	mm	inches	mm	inches	mm	Lbs.	Kg.
DEL-6	1	6	23	15 1/2	394	14 1/4	362	11	279	-	-	35	15.9
DEL-10	1	10	38	18 1/4	464	18	457	12 1/2	318	-	-	54	24.5
DEL-15	1	15	57	26	660	18	457	20 1/2	521	-	-	58	26.3
DEL-20	1	20	76	22 1/4	565	21 3/4	552	15 3/8	391	-	-	73	33.1
DEL-30	2	30	114	30 7/8	784	21 3/4	552	24 1/8	613	8	203	100	45.4
DEL-40	2	40	151	32 1/4	819	24	610	25 9/16	649	8	203	125	56.7
DEL-50	2	50	189	32 1/4	819	26 1/2	673	25 1/8	638	8	203	166	75.3
DEN-30	2	30	114	34 1/2	876	20 1/2	521	-	-	8	203	98	44.5
DEN-40	2	40	151	45 1/8	1146	20 1/2	521	-	-	8	203	113	51.3
DEN-52	2	50	189	54 7/8	1394	20 1/2	521	-	-	8	203	131	59.4
DEN-66	2	66	250	60 3/4	1543	21 3/4	552	-	-	8	203	176	79.8
DEN-80	2	80	303	59 3/8	1508	24	610	-	-	8	203	211	95.7
DEN-120	2	119	450	62 7/16	1586	29 3/8	746	-	-	8	203	326	147.9

RECOVERY CAPACITIES

Element Wattage (Upper/Lower)	INPUT KW	U.S. Gallons/Hr and Litres/Hr at TEMPERATURE RISE INDICATED												
		F° C°	36F° 20C°	40F° 22.2C°	54F° 30C°	60F° 33.3C°	72F° 40C°	80F° 44.4C°	90F° 50C°	100F° 55.5C°	108F° 60C°	120F° 66.6C°	126F° 70C°	
NON-SIMULTANEOUS OPERATION														
/1500	1.5	GPH	17	15	11	10	8	8	7	6	6	5	5	
		LPH	64	58	43	38	32	29	26	23	21	19	18	
/2000	2.0	GPH	23	20	15	14	11	10	9	8	8	7	6	
		LPH	85	77	57	51	43	38	34	31	28	26	24	
/2500	2.5	GPH	28	25	19	17	14	13	11	10	9	8	8	
		LPH	107	96	71	64	53	48	43	38	36	32	30	
3000/3000	3.0	GPH	34	30	23	20	17	15	14	12	11	10	10	
		LPH	128	115	85	77	64	58	51	46	43	38	37	
4000/4000	4.0	GPH	45	41	30	27	23	20	18	16	15	14	13	
		LPH	170	153	114	102	85	77	68	61	57	51	49	
4500/4500	4.5	GPH	51	46	34	30	25	23	20	18	17	15	14	
		LPH	192	173	128	115	96	86	77	69	64	58	55	
5000/5000	5.0	GPH	56	51	38	34	28	25	23	20	19	17	16	
		LPH	213	192	142	128	107	96	85	77	71	64	61	
6000/6000	6.0	GPH	68	61	45	41	34	30	27	24	23	20	19	
		LPH	256	230	170	153	128	115	102	92	85	77	73	
SIMULTANEOUS OPERATION														
3000/3000	6	GPH	68	61	45	41	34	30	27	24	23	20	19	
		LPH	256	230	170	153	128	115	102	92	85	77	73	
4000/4000	8	GPH	90	81	60	54	45	41	36	32	30	27	26	
		LPH	341	307	227	205	170	153	136	123	114	102	97	
4500/4500	9	GPH	101	91	68	61	51	46	41	36	34	30	29	
		LPH	384	345	256	230	192	173	153	138	128	115	110	
5000/5000	10	GPH	113	101	75	68	56	51	45	41	38	34	32	
		LPH	426	384	284	256	213	192	170	153	142	128	122	
6000/6000	12	GPH	135	122	90	81	68	61	54	49	45	41	39	
		LPH	511	460	341	307	256	230	205	184	170	153	146	

Recovery capacities at 100° F rise equal: for non-simultaneous element operation = 4.1 gal. x KW of one element; for simultaneous element operation = 4.1 gal. x 2/3 KW of both elements. For other rises multiply element KW as previously explained by 410 and divide by temperature rise. Full load current for single phase = total watts ÷ voltage.

FOREWORD

Thank you for buying this energy efficient water heater from State. We appreciate your confidence in our products. Detailed installation diagrams are in this manual. These diagrams will serve to provide the installer with a reference for the materials and method of piping suggested. IT IS NECESSARY THAT ALL WATER PIPING AND THE ELECTRICAL WIRING BE INSTALLED AND CONNECTED AS SHOWN IN THE DIAGRAMS.

In addition to these instructions, the water heater must be installed in accordance with local codes and the authority having jurisdiction.

GENERAL SAFETY INSTRUCTIONS

BE SURE TO TURN OFF POWER WHEN WORKING ON OR NEAR THE ELECTRICAL SYSTEM OF THE HEATER. NEVER TOUCH ELECTRICAL COMPONENTS WITH WET HANDS OR WHEN STANDING IN WATER. WHEN REPLACING FUSES ALWAYS USE THE CORRECT SIZE FOR THE CIRCUIT.

The principal components of the heater are identified on page 6. The model and rating plate on page 5 interprets certain markings into useful information. Both of these references should be used to identify the heater, its components and optional equipment.

WARNING

FOR CALIFORNIA INSTALLATION THIS WATER HEATER MUST BE BRACED, ANCHORED, OR STRAPPED TO AVOID FALLING OR MOVING DURING AN EARTHQUAKE. SEE INSTRUCTIONS FOR CORRECT INSTALLATION AND PROCEDURES. INSTRUCTIONS MAY BE OBTAINED FROM YOUR LOCAL DEALER, WHOLESALER, PUBLIC UTILITIES OR CALIFORNIA'S OFFICE OF STATE ARCHITECT, 400 P STREET, SACRAMENTO, CALIFORNIA 95814.

INSULATION BLANKETS

Insulation blankets available to the general public for external use on electric water heaters are not approved for use on your State water heater. The purpose of an insulation blanket is to reduce the standby heat loss encountered with storage tank water heaters. Your State water heater meets or exceeds the National Appliance Energy Act standards with respect to insulation and standby loss requirements, making an insulation blanket unnecessary.

WARNING

Should you choose to apply an insulation blanket to this heater, you should follow these instructions (See page 5 for identification of components mentioned below). Failure to follow these instructions can result in fire, serious personal injury or death.

- Do not cover the temperature & pressure relief valve.
- Do not cover the instruction manual. Keep it on the side of the water heater or nearby for future reference.
- Do obtain new labels from State Water Heaters for placement on the blanket directly over the existing labels.

EXTENDED NON-USE PERIODS

CAUTION

HYDROGEN GAS CAN BE PRODUCED IN A HOT WATER SYSTEM SERVED BY THIS HEATER THAT HAS NOT BEEN USED FOR A LONG PERIOD OF TIME (GENERALLY TWO WEEKS OR MORE). HYDROGEN GAS IS EXTREMELY FLAMMABLE. To

reduce the risk of injury under these conditions, it is recommended that the hot water faucet be opened for several minutes at a nearby kitchen sink before using any electrical appliance connected to the hot water system. If hydrogen is present, there will probably be an unusual sound such as air escaping through the pipe as the water begins to flow. **THERE SHOULD BE NO SMOKING OR OPEN FLAME NEAR THE FAUCET AT THE TIME IT IS OPENED.**

CAUTION

AN ELECTRICAL GROUND IS REQUIRED TO REDUCE RISK OF ELECTRIC SHOCK OR POSSIBLE ELECTROCUTION. THE GROUND SCREW AT THE JUNCTION BOX IS FOR BONDING THE HEATER TO A GROUNDED SERVICE ENTRANCE CONDUCTOR, A GROUNDED SERVICE ENTRANCE RACEWAY, OR AN EARTH GROUNDING ELECTRODE CONDUCTOR.

WARNING

FAILURE TO FOLLOW THESE INSTRUCTIONS CAN RESULT IN SERIOUS PERSONAL INJURY OR DEATH.

REQUIRED ABILITY

INSTALLATION OR SERVICE OF THIS WATER HEATER REQUIRES ABILITY EQUIVALENT TO THAT OF A LICENSED TRADESMAN IN THE FIELD INVOLVED. PLUMBING AND ELECTRICAL WORK ARE REQUIRED.

GENERAL

The installation must conform to these instructions, the local code authority having jurisdiction, and the requirements of the power company. In the absence of code requirements follow the current edition of NFPA-70, The National Electrical Code which may be ordered from: National Fire Protection Association, 1 Batterymarch Park, Quincy, MA 02269.

LOCATION

The water heater should be located as close as possible to/ or centralized to the water piping system. The water heater should be located in an area not subject to freezing temperatures.

The heater should be located in an area where leakage of the tank or connections will not result in damage to the area adjacent to the heater or to lower floors of the structure.

When such locations cannot be avoided, a suitable drain pan should be installed under the heater.

Such pans should be at least two inches deep, have a minimum length and width of at least two inches greater than the diameter of the heater and should be piped to an adequate drain.

Drain pans suitable for these heaters are available from your distributor or A.O. Smith Water Heater Parts Fulfillment, 125 Southeast Parkway, Franklin, TN 37068.

Water heater life depends upon water quality, water pressure and the environment in which the water heater is installed. Water heaters are sometimes installed in locations where leakage may result in property damage, even with the use of a drain pan piped to a drain. However, unanticipated damage can be reduced or prevented by a leak detector or water shut-off device used in conjunction with a piped drain pan. These devices are available from some plumbing supply wholesalers and retailers, and detect and react to leakage in various ways:

- Sensors mounted in the drain pan that trigger an alarm or turn off the incoming water to the water heater when leakage is detected.

- Sensors mounted in the drain pan that turn off the water supply to the entire home when water is detected in the drain pan.
- Water supply shut-off devices that activate based on the water pressure differential between the cold water and hot water pipes connected to the water heater.
- Devices that will turn off the gas supply to a gas water heater while at the same time shutting off its water supply.

CLEARANCES

A minimum clearance of 4" must be allowed for access to replaceable parts such as thermostats, drain valve and relief valve.

Adequate clearance for servicing this appliance should be considered before installation, such as changing the anodes, etc.

FLOOD WARNING

IF THE HEATER BECOMES IMMERSSED IN WATER UP TO OR ABOVE THE LEVEL OF THE BOTTOM OF THE ELEMENT DOORS, THE HEATER SHOULD BE EXAMINED BY A COMPETENT SERVICE PERSON BEFORE IT IS PLACED IN OPERATION.

CHEMICAL VAPOR CORROSION

Water heater corrosion and component failure can be caused by the heating and breakdown of airborne chemical vapors. Spray can propellants, cleaning solvents, refrigerator and air conditioning refrigerants, swimming pool chemicals, calcium and sodium chloride, waxes, and process chemicals are typical compounds which are potentially corrosive. These materials are corrosive at very low concentration levels with little or no odor to reveal their presence. Products of this sort should not be stored near the heater.

ELECTRICAL (GENERAL)

Check the heater model and rating plate information against the characteristics of the branch circuit electrical supply. **DO NOT CONNECT THE HEATER TO AN IMPROPER SOURCE OF ELECTRICITY.** Contact the heater supplier for conversion information if necessary.

Voltage applied to the heater should not vary more than +5% to -10% of the model and rating plate marking for satisfactory operation.

DO NOT ENERGIZE THE BRANCH CIRCUIT FOR ANY REASON BEFORE THE HEATER TANK IS FILLED WITH WATER. DOING SO WILL CAUSE THE HEATING ELEMENTS TO BURN OUT.

The factory wiring is attached to a terminal block within the external junction box unit. The branch circuit is connected to the terminal block within this junction box. The water heater should be connected to a separate, grounded, branch circuit with overcurrent protection and disconnect switch. The water heater should be grounded in accordance with national and local codes.

BRANCH CIRCUIT

The branch circuit wire size should be established through reference to the current edition of NFPA-70, the National Electrical Code or other locally approved source in conjunction with the heater amperage rating. For convenience, portions of the wire size tables from the Code are reproduced here. The branch circuit should be sized at 125 percent of the heater rating and further increase wire size as necessary to compensate for voltage drop in long runs.

CALCULATING AMPERAGE/OVERCURRENT PROTECTION

The heaters come from the factory in two configurations:

1. Two wire C-2 circuit for single element heater equipped with a high limit control, single phase power input.
2. Four wire A-8 circuit for dual element heater equipped with two high limit controls, single phase or three phase power input.

The heater with dual elements is factory wired for connection to a three wire, three-phase delta branch circuit, non-simultaneous operation. In addition a ground conductor is required.

Element connection is for non-simultaneous operation. This means only one element at a time operates. The wiring diagram, on page 5, shows the heater may be field converted to simultaneous element operation by moving the red wire on "J" terminal to L1. It is then possible for both elements to operate at once as determined by the thermostats. Regardless of element connection the heater operates in an "unbalanced" fashion.

The heater may be field converted to single-phase operation by moving the wire on L3 of the terminal block to L2. L3 is not used, see page 5.

The heater, now in single-phase non-simultaneous operation, may be field-converted to single phase simultaneous operation by moving the red wire on terminal "J" to L1, see page 5.

This is an example of calculating heater amperage for both types of element operation. From this, the branch circuit conductor and overcurrent protection sizing can be established.

The example is of a three-phase 240 volt unit with two, 6 kw elements. The notations are for units field converted to single-phase. Check the heater model and rating plate for actual specifications and substitute those values in the following.

Non-simultaneous: (as factory wired)	Simultaneous: (Field conversion)
3000 ÷ 240 = 12.5 amps*	3000 ÷ 240 = 12.5 amps* 12.5 x 1.73 = 21.6 amps
*NOTE: as a single-phase non-simultaneous unit.	*NOTE: as a single-phase simultaneous unit the total is: 12.5 x 2 = 25 amps

The rating of the overcurrent protection should be computed on the basis of 125 percent of the total connected load amperage. Where the standard ratings and settings do not correspond with this computation, the next higher standard rating or setting should be selected.

Portion of Table 310-16 (NFPA-70) follows:

Allowable Ampacities of Insulated Copper Conductors. Not more than three conductors in Raceway or Cable or Direct Burial (Based on Ambient Temperature of 30° C, 86° F).

These ampacities relate only to conductors described in Table 310-13 in Code.

For ambient temperatures over 30° C (86° F), see Correction Factors, Note 13 in Code.

For ambient temperatures over 30° C (86° F), see Correction Factors, Note 13 in Code.

Size	Temperature Rating of Conductor See Table 310-13 in Code	
	60° C (140° F)	75° C (167° F)
AMG MCM	TYPES: RUW (14-2), T, TW, UF	TYPES: RH, RHW, RUH, (14-2), THW THWN, XHHW, USE
18	---	---
16	---	---
14	15	15
12	20	20
10	30	30
8	40	45
6	55	65
4	70	85
3	80	100

Not more than three conductors in Raceway or Cable or Direct Burial (Based on Ambient Temperature of 30° C, 86° F. These ampacities relate only to conductors described in Table 310-13 in Code.

For ambient temperatures over 30° C (86° F), see Correction Factors, Note 13 in Code.

Size	Temperature Rating of Conductor See Table 310-13 in Code	
	60° C (140° F)	75° C (167° F)
AMG MCM	TYPES: RUW (12-2), T, TW, UF	TYPES: RH, RHW, RUH, (12-2), THW THWN, XHHW, USE
12	15	15
10	25	25
8	30	40
6	40	50
4	55	65
3	65	75
2	75	90
1	85	100

Portion of Table 310-18 follows:

Allowable Ampacities of Insulated Aluminum and Copper -Clad Aluminum Conductors.

WIRING DIAGRAMS

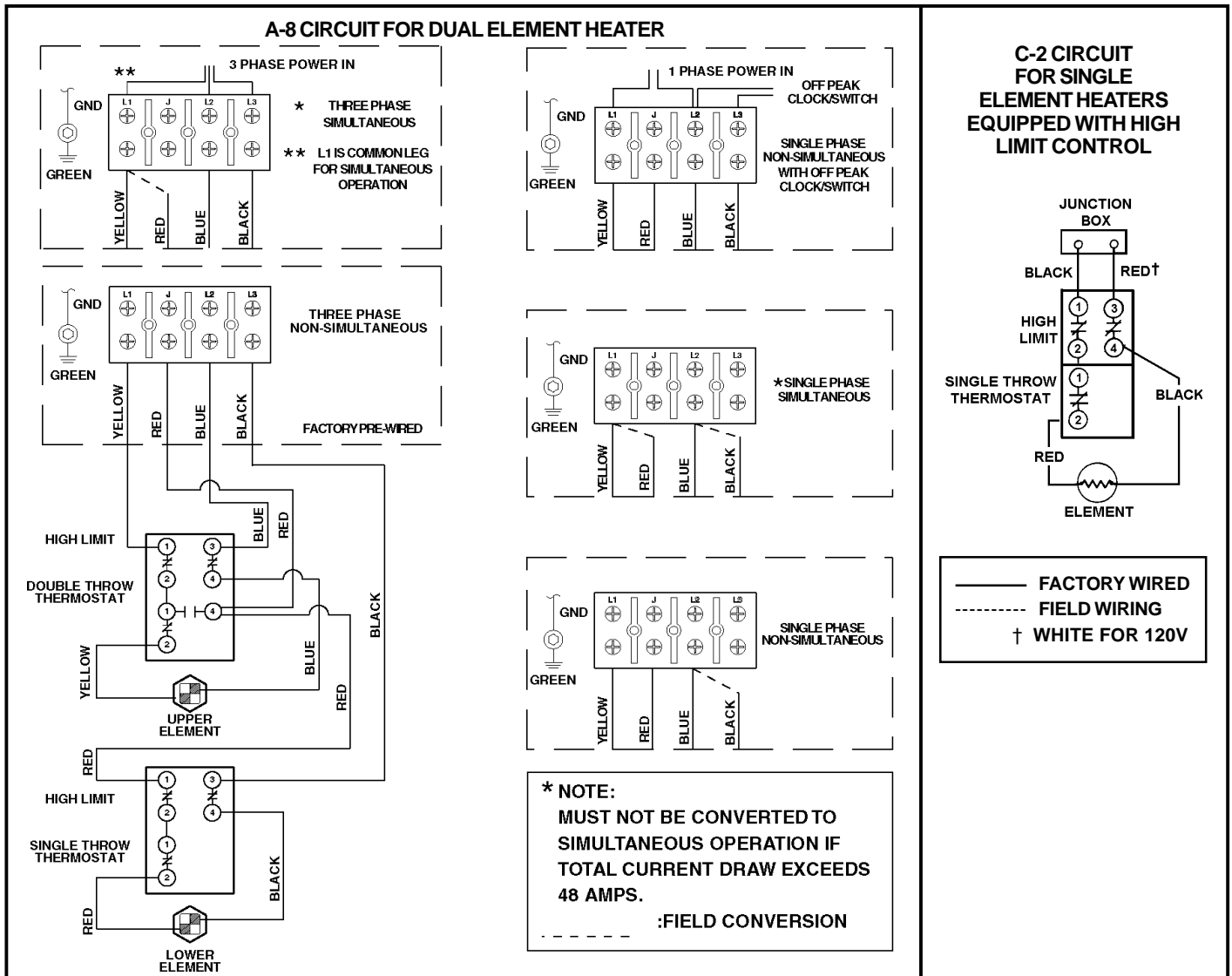

TYPICAL PIPING CONNECTIONS

This page shows typical water heater installations by model designations.

DUAL ELEMENTS HEATER

SINGLE ELEMENT HEATER



INSTALL SUITABLE DRAIN PANS UNDER HEATERS TO PREVENT DAMAGE DUE TO LEAKAGE. REFER TO WATER HEATER LOCATION ON PAGE 2.

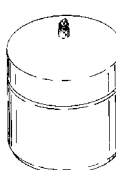

INSTALL THERMAL EXPANSION TANK IF CHECK VALVE OR PRESSURE REDUCING VALVE IS USED IN SUPPLY LINE.



INSTALL VACUUM RELIEF IN COLD WATER INLET LINE AS REQUIRED BY LOCAL CODES.

† OVER CURRENT PROTECTION MUST BE SUPPLIED IN WATER HEATER CIRCUIT. CONSULT LOCAL CODE OR NEC-1984 FOR PROPER INSTALLATION.

* INSTALL IN ACCORDANCE WITH ALL LOCAL CODES.

TEMPERATURE AND PRESSURE RELIEF VALVE



TO REDUCE THE RISK OF EXCESSIVE PRESSURES AND TEMPERATURES IN THIS WATER HEATER, INSTALL TEMPERATURE AND PRESSURE PROTECTIVE EQUIPMENT REQUIRED BY LOCAL CODES BUT NOT LESS THAN A COMBINATION TEMPERATURE AND PRESSURE RELIEF VALVE CERTIFIED BY A NATIONALLY RECOGNIZED TESTING LABORATORY THAT MAINTAINS PERIODIC INSPECTION OF PRODUCTION OF LISTED EQUIPMENT OR MATERIALS, AS MEETING THE REQUIREMENTS FOR RELIEF VALVE DEVICES FOR HOT WATER SUPPLY SYSTEMS. (ANSI Z21.22.)

This valve must be marked with a maximum set pressure not to exceed the marked maximum working pressure of the water heater. Install the valve into an opening provided and marked for this purpose in the water heater, and orient it or provide tubing so

that any discharge from the valve will exit only within 6 inches above, or at any distance below, the structural floor and cannot contact any live electrical part. THE DISCHARGE OPENING MUST NOT BE BLOCKED OR REDUCED IN SIZE UNDER ANY CIRCUMSTANCES.

DUAL ELEMENT RATING PLATE

SINGLE ELEMENT RATING PLATE

COMMERCIAL STORAGE TANK WATER HEATER						HOUSEHOLD STORAGE TANK WATER HEATER					
UL LISTED 932N						UL LISTED 932N					
MODEL NUMBER		SERIAL NUMBER		ITEM ID / PART NUMBER		MODEL NUMBER		SERIAL NUMBER		ITEM ID / PART NUMBER	
WATTS UPPER	WATTS LOWER	WATTS UPPER	WATTS LOWER	CAPACITY US GALS	MAX. WORKING PRESSURE	WATTS UPPER	WATTS LOWER	TOTAL WATTS CONNECTED	CAPACITY US GALS	MAX. WORKING PRESSURE	
VOLTS - AC PHASE		CIRCUIT				VOLTS - AC PHASE		CIRCUIT			
TOTAL WATTS CONNECTED		INTERLOCK SIMULTANEOUS		CITY OF NEW YORK DEPT. OF BUILDING REG.		TOTAL WATTS CONNECTED		CIRCUIT		CITY OF NEW YORK DEPT. OF BUILDING REG.	

OPERATION

⚠ CAUTION

DO NOT OPERATE THE HEATER WITHOUT INSTALLING AN APPROVED TEMPERATURE AND PRESSURE RELIEF VALVE IN THE OPENING PROVIDED IN THE TANK. GROUND THE HEATER TO GUARD AGAINST ELECTRIC SHOCK FROM THE HEATER OR WATER SYSTEM. NEVER OPERATE THE HEATER WITHOUT FILLING WITH WATER PER THE FILLING INSTRUCTIONS. FAILURE TO DO SO WILL DAMAGE INTERNAL PARTS.

FILLING

1. Close the water heater drain valve by turning hand-wheel to right (clockwise).
2. Open a nearby hot water faucet to permit the air in the system to escape.
3. Fully open the cold water inlet valve allowing the heater and piping to be filled.
4. Close the hot water faucet as water starts to flow.
5. Turn on the electrical switch to the water heater.

⚠ WARNING

DO NOT ATTEMPT TO OPERATE HEATER WITH COLD WATER INLET VALVE CLOSED.

TEMPERATURE REGULATION

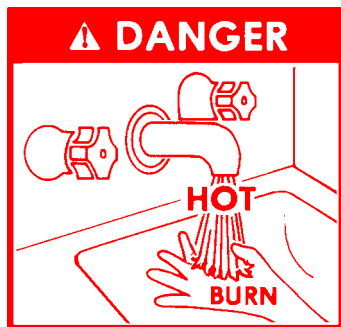

⚠ DANGER

THE WATER HEATER IS EQUIPPED WITH AN ADJUSTABLE THERMOSTAT TO CONTROL WATER TEMPERATURE. HOT WATER AT TEMPERATURES DESIRED FOR AUTOMATIC DISHWASHER AND LAUNDRY USE CAN CAUSE SCALDS RESULTING IN SERIOUS PERSONAL INJURY AND/OR DEATH. THE TEMPERATURE AT WHICH INJURY OCCURS VARIES WITH THE PERSON'S AGE AND TIME OF EXPOSURE. THE SLOWER RESPONSE TIME OF CHILDREN, AGED OR DISABLED PERSONS INCREASES THE HAZARD TO THEM. NEVER ALLOW SMALL CHILDREN TO USE A HOT WATER TAP, OR TO DRAW THEIR OWN BATH WATER. NEVER LEAVE A CHILD OR DISABLED PERSON UNATTENDED IN A BATHTUB OR SHOWER.

It is recommended that lower water temperatures be used to avoid the risk of scalding. It is further recommended, in all cases, that the water temperature thermostats (See Figure 3) be set for the lowest temperature which satisfies your hot water needs. This will also provide the most energy efficient operation of the water heater.

Figure 3 shows the approximate time-to-burn relationship for normal adult skin. The thermostats on your water heater have a linear relationship between degrees of angular rotation and the corresponding change in temperature. Thus rotating the temperature adjustment indicator 30 angular degrees will result in a 10 degree Fahrenheit change in water temperature.

Temperature Setting	Time to Produce 2nd & 3rd Degree Burns on Adult Skin
180° F (82° C)	Nearly instantaneous
160° F (71° C)	About 1/2 second
150° F (66° C)	About 1-1/2 seconds
140° F (60° C)	Less than 5 seconds
130° F (54° C)	About 30 seconds
125° F (52° C)	About 2 minutes
120° F (49° C)	More than 5 minutes

FIGURE 3

TEMPERATURE ADJUSTMENT

The water temperature is controlled by surface mounted thermostats with hi-limit. There is one mounted firmly against the tank directly above each element. The thermostats of A-8 circuit are adjustable from approximately 120°F (49°C) (lowest setting) to 180°F (82°C) (highest setting). The thermostat of C-2 circuit is adjustable from approximately 110°F (43°C) to 170°F (77°C) with a factory set point 120°F (49°C). The over temperature device (hi-limit) attached to each thermostat has a manual reset.

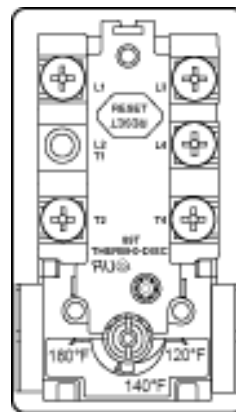

ADJUSTABLE UPPER THERMOSTAT BEHIND JUNCTION BOX DOOR

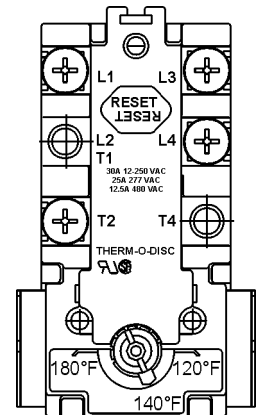

ADJUSTABLE LOWER (SINGLE) THERMOSTAT

FIGURE 4

NOTE: It is not necessary to adjust the upper thermostat for a dual element unit. However, if it is adjusted above the factory set point 140°F (60°C) it is recommended that it not be set higher than the lower thermostat setting.

To change the temperature setting:

⚠ DANGER

1. Turn off the heater electrical supply. Do not attempt to adjust thermostat with power on.
2. Open the junction box door (for upper thermostat of dual element water heater only) and/or remove the (lower) thermostat access panel. Do not remove the plastic personnel protectors covering the thermostats. The thermostat is factory pre-set at 140°F (60°C) for dual element units or at 120°F (49°C) for single element units.

- Using a flat tip screwdriver, rotate the adjusting knob to the desired temperature setting.
- Replace the covers and access panels, and turn on heater electrical supply.

Valves for reducing point-of-use temperature by mixing cold and hot water are available (See Figure 5). Also available are inexpensive devices that attach to faucets to limit hot water temperatures. Contact a licensed plumber or the local plumbing authority.

A non-adjustable high temperature limit control operates before steam temperatures are reached. The high limit is in the same area as the upper thermostat and must be reset manually when it operates. **BECAUSE THE HIGH LIMIT OPERATES ONLY WHEN ABNORMALLY HIGH WATER TEMPERATURES ARE PRESENT, IT IS IMPORTANT THAT A QUALIFIED SERVICE AGENT BE CONTACTED TO DETERMINE THE REASON FOR OPERATION BEFORE RESETTING.**

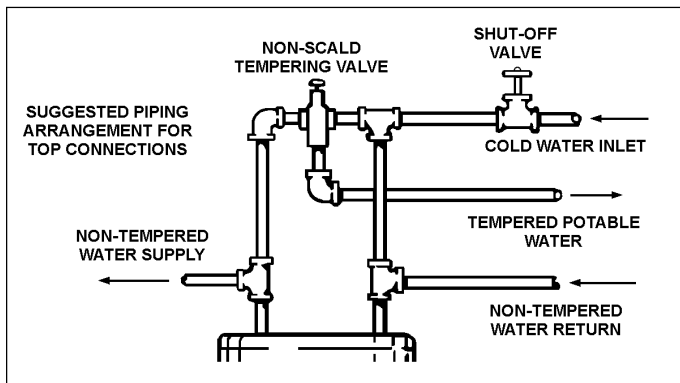

FIGURE 5
DRAINING

If the heater is to be shut down and exposed to freezing temperatures, it must be drained. Water, if left in the tank and allowed to freeze, will expand and damage the heater.

- Turn off the electrical switch and cold water inlet valve.
 - If desired, a hose may be connected to the drain valve to carry the water away.
- Open a nearby hot water faucet and the heater drain valve.
 - Be careful to grasp the drain valve handle in such a way that the hand will not be exposed to hot water.
- The drain valve must be left open during the shutdown period.
 - To restart heater, refer to the foregoing FILLING instructions.

MAINTENANCE

Electric water heater maintenance consists of cleaning the tank and removing lime (or scale) from the heating elements in hard water areas. Tank flushing should be performed monthly. Tank sediment removal and element lime scale removal must be performed when needed as determined by periodic inspections. Your dealer should be contacted for element cleaning. In some instances a hissing sound may be heard as the scale builds up. This noise is normal.

Once a month the temperature and pressure relief valve should be checked to ensure that it is in operating condition. Lift the lever on the valve several times until the valve seats properly and operates freely.



CAUTION
THE WATER PASSING OUT OF THE VALVE DURING THIS CHECKING OPERATION MAY BE EXTREMELY HOT.

It is recommended that the drain valve on this unit be opened once a month and 1 to 2 gallons of water be allowed to drain out. This will help to prevent sediment buildup in the tank bottom.

ANODE INSPECTION AND REPLACEMENT

This water heater is equipped with a sacrificial anode rod. Anodes protect the glass-lined tank from corrosion by sacrificing themselves through electrolysis. When the anode material is consumed, there is no more protection and corrosion of the tank accelerates.

Inspection of the anode every 6 to 12 months allows you to identify a spent anode and replace it. Replace the anode when its diameter is 3/8" (1 cm) of an inch, or annually whichever is first. Aggressive, very hot and softened water causes rapid consumption of the anode requiring frequent inspections. Anodes are available from your distributor or A.O. Smith.

TROUBLESHOOTING

CHECKLIST

Before contacting your dealer, check the water heater to see if the apparent malfunction is caused by some external fault. Consulting this checklist may eliminate the need for a repair call and restore hot water service.

NOT ENOUGH OR NO HOT WATER

- Be certain that the water heater electrical switch is turned to the ON position.
 - In some areas an additional special meter, controlled by a timer, is used to govern the periods electricity is available. If the heater operates on a timed electrical circuit, recovery will be limited to certain hours.
- Check for loose or blown fuses in the water heater circuit.
- If the water has been excessively hot and is now cold, the high temperature limit control may have operated. To restore service, contact your dealer or utility company. Refer to TEMPERATURE REGULATION section.
- The storage capacity of the heater may have been exceeded by large demands of hot water.
- If the heater was installed when incoming water temperatures were warm, colder incoming temperatures will create the effect of less hot water.

6. Look for leaking or open hot water faucets.

WATER IS TOO HOT

1. Refer to TEMPERATURE REGULATION section.

WATER HEATER MAKES SOUNDS

1. See MAINTENANCE

WATER LEAKAGE IS SUSPECTED

1. Check to see if the heater drain valve is tightly closed.
2. The apparent leakage may be condensation which forms on cool surfaces of the heater and piping.
3. If the outlet of the relief valve is leaking it may represent:
 - Excessive water pressure.
 - Excessive water temperature.
 - Faulty relief valve.

Excessive water pressure is the most common cause of relief valve leakage. It is often caused by a "closed system". A check

valve in the inlet system will not permit the expanded hot water volume to equalize pressure with the main. A relief valve must release this water or the water heater or plumbing system will be damaged.

When such a condition is encountered, local codes or inspection agency should be consulted to determine which system is acceptable in your area. These may consist of:

- Installation of a second relief valve with lower setting than the primary safety relief valve.
- An expansion tank of suitable pressure and provision to avoid water logging.
- Removal of the check valve.

IF YOU CANNOT IDENTIFY OR CORRECT THE SOURCE OF THE MALFUNCTION

1. Place the water heater electrical switch in the OFF position.
2. Close the cold water inlet valve to the heater.
3. Contact your dealer.

NOTES

LEAKAGE CHECKPOINTS

Instructions: Use this illustration as a guide when checking for sources of water leakage. You or your dealer may be able to correct what appears to be a problem. **NOTE: Cover and Insulation shown removed to reveal tank top**

Where possible remove or lift top cover to examine threads of fittings installed into tank for evidence of leakage. Correct fitting leaks as necessary.

Water leaks at the elements may be due to:

1. Defective element which leaks at terminals or thru flange. Replace element*.
2. Loose element/gasket leak:
 - (a) Screw-in type: tighten with 1-1/2" socket wrench or Part Number 23985 wrench. If leak continues, remove element*, discard gasket and clean thread areas. Apply nonhardening Permatex Number 2 to thread areas, install new gasket and screw element into fitting until it seats. Tighten 1/2 to 3/4 turn with wrench.
 - (b) Flange type: tighten screw with wrench. If leak continues remove element* and discard gasket. Clean gasket seating areas and re-install element with new gasket. NOTE: Part Number 40000-1 scale cleaning replacement screws available where threads have become rusted or damaged, preventing tightening.

All water which appears at the heater bottom or on the surrounding floor may be caused by condensation, loose connections or relief valve operation and leakage. Do not replace the heater until full inspection of all potential leak points is made and corrective steps taken to stop the leak. Leakage from other appliances, water lines or ground seepage should also be suspected until proven otherwise.

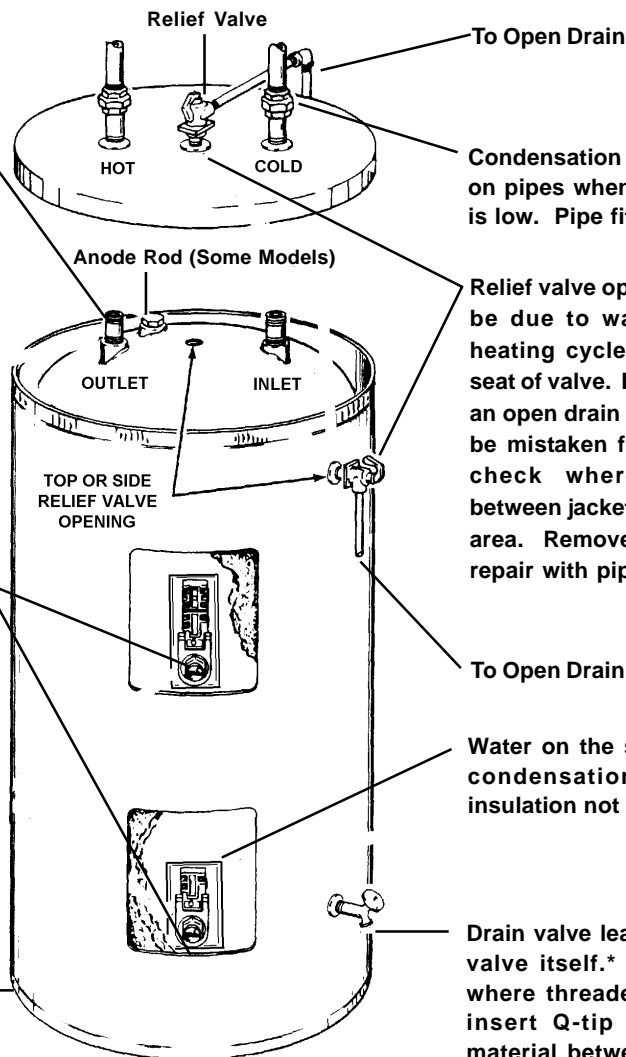

Condensation and dripping may appear on pipes when cold water temperature is low. Pipe fitting may be leaking.

Relief valve operation and leakage may be due to water expansion during heating cycle or foreign material on seat of valve. If the valve is not piped to an open drain the released water could be mistaken for a leaking heater. To check where threaded material between jacket opening and swab spud area. Remove valve* if indicated and repair with pipe joint compound.

To Open Drain

Water on the side of the tank may be condensation due to the panel or insulation not being in place.

Drain valve leakage could be from the valve itself.* To check for leakage where threaded portion enters tank, insert Q-tip or similar absorbent material between jacket opening and valve to swab spud area. Remove valve* if leak is indicated and repair with pipe joint compound.

*Contact your dealer as it is necessary to shut off electricity and drain tank to perform procedure.

MODELS DEN AND DEL ELECTRIC WATER HEATER LIMITED WARRANTY

A. O. Smith Corporation, the warrantor, extends the following LIMITED WARRANTY to the owner of this water heater:

1. THE TANK

If the glass-lined tank in this water heater shall prove upon examination by the warrantor to have leaked due to natural corrosion from potable water therein, during the first THREE years after initial installation, the warrantor will supply a complete new A. O. Smith water heater of equivalent size and current model. Some government agencies are requiring energy efficient standards for water heaters. In the event regulations prohibit sale of a model of equivalent size and construction, A. O. Smith will provide a model which complies with the regulations of your area, in which case the consumer will be charged the difference in price between the like replacement and the energy efficient model required. The warranty on the replacement water heater will be limited to the unexpired term of the original warranty.

2. ALL OTHER PARTS

If within ONE year after initial installation of this water heater, any part or portion shall prove upon examination by the warrantor to be defective in material or workmanship, the warrantor will repair or replace such part or portion at its option.

3. CONDITIONS and EXCEPTIONS

This warranty shall apply only when the water heater is installed in accordance with local plumbing and building codes, ordinances and regulations, the printed instructions provided with it and good industry practices. In addition, a temperature and pressure relief valve, certified by A. G. A. and approved by the American Society of Mechanical Engineers, must have been installed.

a. This warranty shall apply only when the heater is:

- (1) used at temperatures not exceeding the maximum calibrated setting of its thermostat;
- (2) used at water pressure not exceeding the working pressure shown on the heater;
- (3) filled with potable water, free to circulate at all times and with the tank free of damaging water sediment or scale deposits;
- (4) used in a non-corrosive and non-contaminated atmosphere;
- (5) used with factory approved anode(s) installed;
- (6) in its original installation location;
- (7) in the United States, its territories or possessions, and Canada;
- (8) sized in accordance with proper sizing techniques for commercial water heaters;
- (9) bearing a rating plate which has not been altered, defaced or removed, except as required by the warrantor;
- (10) used in an open system or in a closed system with properly sized and installed thermal expansion tank;
- (11) fired at the proper voltage and wattage as stated on the rating plate;
- (12) maintained in accordance with the instructions printed in the manual included with the heater.

b. Any accident to the water heater, any misuse, abuse (including freezing) or alteration of it, any operation of it in a modified form, or any attempt to repair tank leaks will void this warranty.

4. SERVICE and REPAIR EXPENSE

Under this limited warranty the warrantor will provide only a replacement water heater or part thereof. The owner is responsible for all other costs. Such costs may include but are not limited to:

- a. Labor charges for service, removal, repair, or reinstallation of the water heater or any component part;
- b. Shipping, delivery, handling, and administrative charges for forwarding the new heater or replacement part from the nearest distributor and returning the claimed defective heater or part to such distributor;
- c. All cost necessary or incidental for any materials and/or permits required for installation of the replacement heater or part.

5. LIMITATIONS ON IMPLIED WARRANTIES

Implied warranties, including any warranty of merchantability imposed on the sale of this heater under state law are limited to one (1) year duration for the heater or any of its parts. Some states do not allow limitations on how long an implied warranty lasts, so the above limitation may not apply to you.

6. CLAIM PROCEDURE

Any claim under this warranty should be initiated with the dealer who sold the heater, or with any other dealer handling the warrantor's products. If this is not practicable, the owner should contact:

U.S. Customers
A. O. Smith Water Products Company
500 Tennessee Waltz Parkway
Ashland City, TN 37015
Telephone: 1-800-323-2636

Canadian Customers
A. O. Smith Enterprises, Ltd.
P. O. Box 310- 768 Erie Street
Stratford, Ontario N5A 6T3
Telephone: 1-800-265-8520

- a. The warrantor will only honor replacement with identical or similar water heater or parts thereof which are manufacture or distributed by the warrantor.
- b. Dealer replacements are made subject to in-warranty validation by warrantor.

7. DISCLAIMERS

NO OTHER EXPRESS WARRANTY HAS BEEN OR WILL BE MADE IN BEHALF OF THE WARRANTOR WITH RESPECT TO THE MERCHANTABILITY OF THE HEATER OR THE INSTALLATION, OPERATION, REPAIR, OR REPLACEMENT OF THE HEATER. THE WARRANTOR SHALL NOT BE RESPONSIBLE FOR WATER DAMAGE, LOSS OF USE OF THE UNIT, INCONVENIENCE, LOSS OR DAMAGE TO PERSONAL PROPERTY, OR OTHER CONSEQUENTIAL DAMAGE. THE WARRANTOR SHALL NOT BE LIABLE BY VIRTUE OF THIS WARRANTY OR OTHERWISE FOR DAMAGE TO ANY PERSONS OR PROPERTY, WHETHER DIRECT OR INDIRECT, AND WHETHER ARISING IN CONTRACT OR IN TORT.

- a. Some states do not allow the exclusion or limitation of the incidental or consequential damage, so the above limitation or exclusion may not apply to you.
- b. This warranty gives you specific legal rights, and you may also have other rights which vary from state to state.

Fill in the following for your own reference. Keep it. Registration is not a condition of warranty. The model and serial number are found on the heater's rating plate.

Model No. _____ Serial No. _____ Date Installed _____

Dealer's Name _____

Dealer's Address _____ Phone No. _____

City and State _____ Zip _____

REPAIR PARTS LIST

Now that you have purchased this water heater, should a need ever exist for repair parts or service, simply contact the company it was purchased from or direct from the manufacturer listed on the rating plate on the water heater.

Selling prices will be furnished on request or parts will be shipped at prevailing prices and you will be billed accordingly.

The model number of your Water Heater will be found on the rating plated located above the lower access panel.

Be sure to provide all pertinent facts when you call or visit.

WHEN ORDERING REPAIR PARTS, ALWAYS GIVE THE FOLLOWING INFORMATION:

- MODEL NUMBER
- VOLTAGE AND ELEMENT WATTAGE
- SERIAL NUMBER
- PART DESCRIPTION

Del 6, 10, 15, 20 Series 102 (refer to repair parts table on page 13).

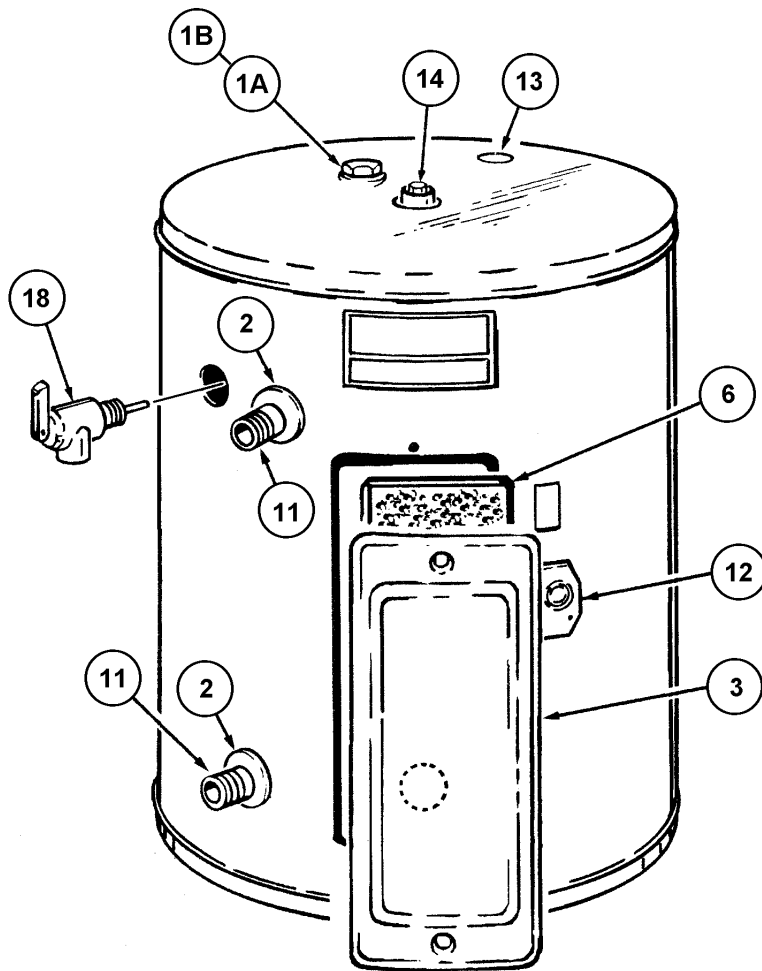
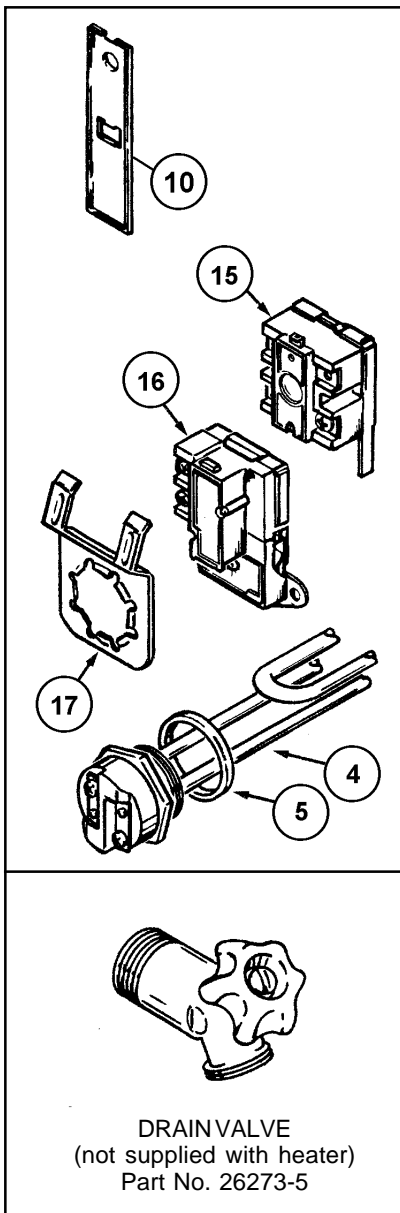

Item	Description	DEL-6	DEL-10	DEL-15	DEL-20
		Series 102	Series 102	Series 102	Series 102
1A	Anode, Alum...	9003942	9003942	9003943	9003944
1B	Anode, Mag. (SMR P72 and S19)	9002110	9002110	9004302	9003721
2	Collar, Pipe	9004610	9004610	9004610	9004610
3	Cover, Front	9003900	9003900	9003900	9003900
4	ELEMENT, HEATING	SEE ELEMENT CHART ON PAGE 14			
5	Gasket, Element	<u>9000308</u>	<u>9000308</u>	<u>9000308</u>	<u>9000308</u>
6	Opening Insulation	43307	43307	43307	43307
7	*Instruction Manual	195201-002	195201-002	195201-002	195201-002
LABEL					
8	*Scald Warning	181138	181138	181138	181138
9	*Temperature Warning	182734	182734	182734	182734
10	Personnel Protector	9003899	9003899	9003899	9003899
11	Pipe Nipple	194130	194130-3	194130-3	194130-3
12	Plate, Knockout	43293-1	43293-1	43293-1	43293-1
PLUG					
13	Cap	42306-1	42306-1	42306-1	42306-1
14	Pipe	9001437	9001437	9001437	9001437
15/16	Thermostat with High Limit Switch	<u>9003945</u>	<u>9003945</u>	<u>9003945</u>	<u>9003945</u>
17	Bracket, Thermostat	9003898	9003898	9003898	9003898
18	Valve, Relief	<u>9003484</u>	<u>9003741</u>	<u>9003741</u>	<u>9003741</u>

*Not Illustrated.

Standard Hardware Items May Be Purchased Locally. Underlined Parts Are Recommended For Emergency Replacement.

DEN 30, 40, 52, 66, 80 & 120, Series 110
 (Refer to Repair Parts Table on Pages 14 & 15)

DEL 30, 40 & 50, Series 110
 (Refer to Repair Parts Table on Pages 14 & 15)

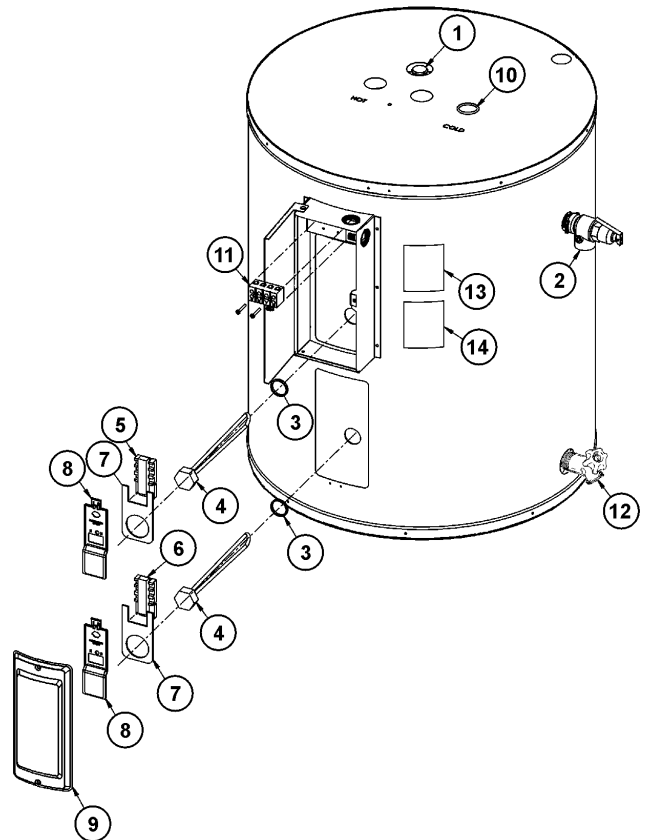
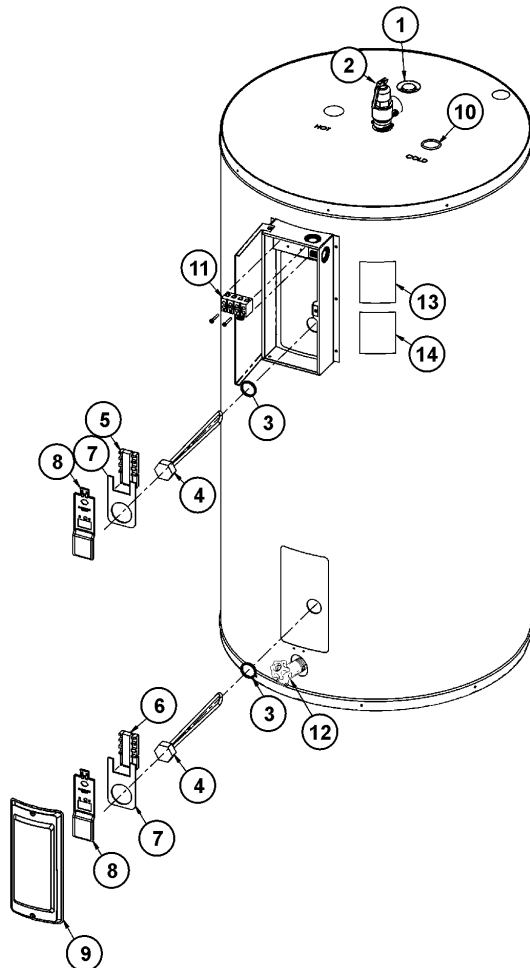

Item	Description	DEL-30 Series 110	DEL-40 Series 110	DEL-50 Series 110	DEN-30 Series 110
1A	Anode, Alum.	9003888	9003889	9003889	9003944
1B	Anode, Mag.(SMR P72)	9003721	9003922	9001834	9003721
2	T&P Relief Valve	9003741	9003741	9003741	9000071
3	Gasket, Element	90000308	90000308	90000308	90000308
4	ELEMENT, each	(SEE ELEMENT & WATTAGE CHART BELOW)			
5	Upper Thermostat w/Hi Limit	<u>9003896</u>	<u>9003896</u>	<u>9003896</u>	<u>9003896</u>
6	Lower Thermostat w/Hi Limit	<u>9003897</u>	<u>9003897</u>	<u>9003897</u>	<u>9003897</u>
7	Thermostat Bracket, each	9003898	9003898	9003898	9003898
8	Terminal Cover, each	9003899	9003899	9003899	9003899
9	Lower Access Panel	9003900	9003900	9003900	9003900
10	Dip Tube	9003902	9003902	9003902	9003902
11	Power Terminal	9005719	9005719	9005719	9005719
12	Drain Valve	9003906	9003906	9003906	9003906
13	Wiring Diagram Label	195203	195203	195203	195203
14	Scald Warning Label	181138	181138	181138	181138
15*	Junction Box Assembly	195171	195171	195171	195171
16*	Manual	195201-002	195201-002	195201-002	195201-002

*Not Illustrated.

Standard Hardware Items May Be Purchased Locally.

Underlined Parts Are Recommended For Emergency Replacement.

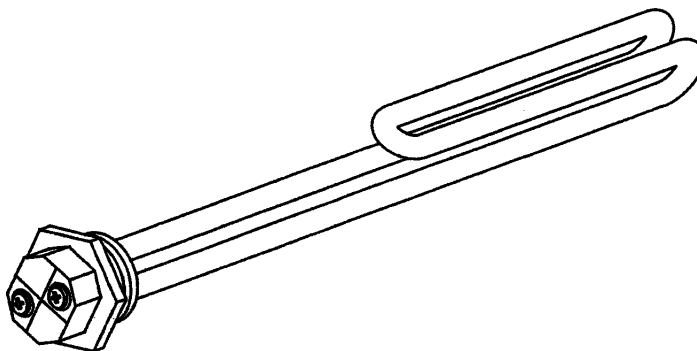

COPPER SHEATH ELEMENT AND WATTAGE CHART

K.W.	ELEMENT WATTAGE	120V	208V	240V	277V	480V
		PART NO.	PART NO.	PART NO.	PART NO.	PART NO.
1.0	1000W	---	9002863	90001431	---	---
1.5	1500W	9002963	9000145	9002864	9001225	---
2.0	2000W	9003947	9002858	9000145	9004709	---
2.5	2500W	9002859	9004712	9002860	9002890	9002861
3.0	3000W	9002862	9002868	9003959	9003958	9003961
3.5	3500W	---	9003950	9004712	---	---
MAX 3.5KW INPUT FOR 6 GALLON UNITS, ELEMENTS BELOW DOTTED LINE CANNOT BE USED ON 6 GALLON UNITS						
4.0	4000W	---	9002867	9002868	9001229	9002869
4.5	4500W	---	9003952	9003950	9003960	9001225
5.0	5000W	---	9001224	9003957	9001231	9001236
5.5	5500W	---	9002871	9002867	---	9002872
6.0	6000W	---	9003953	9003952	9002874	9002875

DEN-40 Series 110	DEN-52 Series 110	DEN-66 Series 110	DEN-80 Series 110	DEN-120 Series 110
... 9003889	9003889	9000029	9003892	9003893
... 9003483	9003487	9003465	9003650	9000734
... 9000071	9000071	9000071	9000071	9000071
... 9000308	9000308	9000308	9000308	9000308
..... (SEE ELEMENT & WATTAGE CHART ON PAGE 14)				
... 9003896	9003896	9003896	9003896	9003896
... 9003897	9003897	9003897	9003897	9003897
... 9003898	9003898	9003898	9003898	9003898
... 9003899	9003899	9003899	9003899	9003899
... 9003900	9003900	9003900	9003900	9003900
... 9003903	9003904	9003905	9003905	9005709
... 9005719	9005719	9005719	9005719	9005719
... 9003906	9003906	9003906	9003906	9003906
.... 195203	195203	195203	195203	195203
.... 181138	181138	181138	181138	181138
.... 195171	195171	195171	195171	195171
.. 195201-002	195201-002	195201-002	195201-002	195201-002

*Not Illustrated.
Standard Hardware Items May Be Purchased Locally.
Underlined Parts Are Recommended For Emergency Replacement.

INCOLOY SHEATH ELEMENT AND WATTAGE CHART (FOR SMR P72)

K.W.	ELEMENT	120V	208V	277V	480V
	WATTAGE	PART NO.	PART NO.	PART NO.	PART NO.
1.5	1500W	9004279	9004283	---	---
2.0	2000W	9004280	9004284	9004290	9004298
2.5	2500W	9004281	9004285	9004295	9004299
----- Incoloy Elements Below dotted line cannot be used on 6 gallon units because of element length -----					
3.0	3000W	9004282	9004751	9004296	9004300
3.5	3500W	---	9003210	---	---
4.0	4000W	---	9004294	9004543	---
4.5	4500W	---	9004287	9004297	9004301
5.0	5000W	---	---	---	---
5.5	5500W	---	9004288	---	---
6.0	6000W	---	9004289	---	---

A.O. Smith
Water Heaters

McBee, South Carolina 29101
Phone: 1-800-527-1953 Fax: 800-433-2515
www.hotwater.com e-mail: parts@hotwater.com