

Hi-Riser Showering

INSTRUCTIONS FOR USE

Codes 3063 & 3067



CONTENTS	PAGE
1.0 INTRODUCTION	1
2.0 ILLUSTRATION OF YOUR HI-RISER SHOWERING CHANGING TABLE	2
3.0 TECHICAL DATA	3
4.0 FOR YOUR SAFETY	4
5.0 SURVEYING AND INSTALLATION	5
6.0 HOW TO USE YOUR HI-RISER SHOWERING CHANGING TABLE	9
7.0 CARE & MAINTENANCE	11
8.0 GUARANTEE & SERVICE	15
9.0 CONTINUOUS IMPROVEMENT	16
10.0 WARRANTY & AFTERSALE	17

1.0 INTRODUCTION

Thank you for choosing the Smirthwaite Hi-Riser Showering changing table.

The Hi-Riser Showering is an easy to use two-in-one wall and floor mounted showering and changing table. The robust and yet slim-line design makes it suitable for children and adults of up to 150kg. Its versatility enables it to be an ideal solution for bathrooms as well as swimming pools and hydrotherapy environments.



IMPORTANT!

These instructions should be read by all therapists and carers using the equipment and should be retained for future reference. The product should always be used under adult supervision.

Any incorrect use of the product and failure to follow the instructions may put the user at risk or impede the function. If you have any queries using this product or wish for further copies, please do not hesitate to contact Customer Service department on T: +44 (0)1626 835552

This product has been designed and manufactured specifically and solely for use by clients with special needs.



2.0 ILLUSTRATION OF YOUR HI-RISER SHOWERING CHANGING TABLE

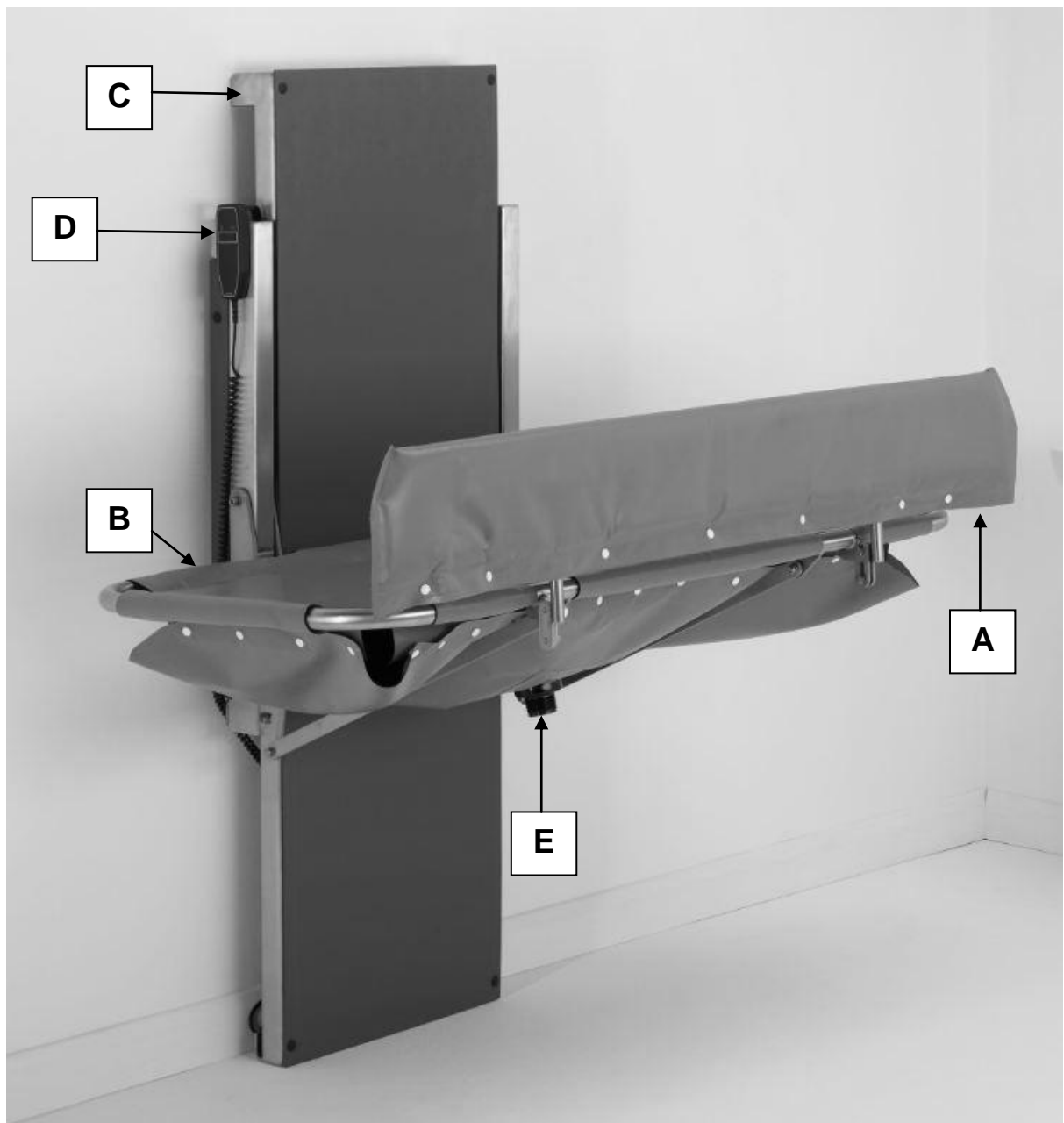

- A. Safety side
- B. Bed
- C. Wall frame
- D. Handset
- E. Drainage outlet



3.0 TECHNICAL DATA

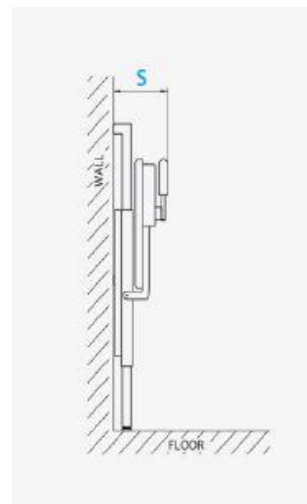
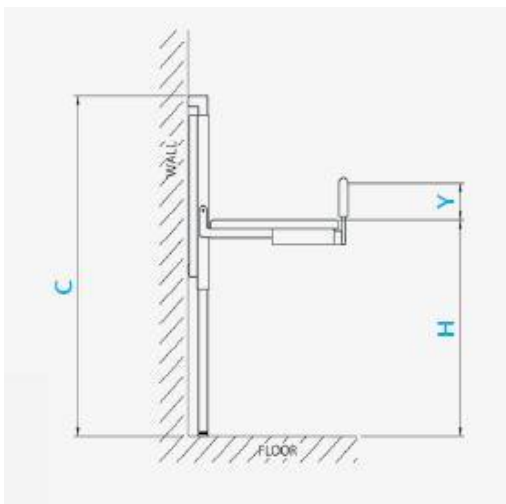
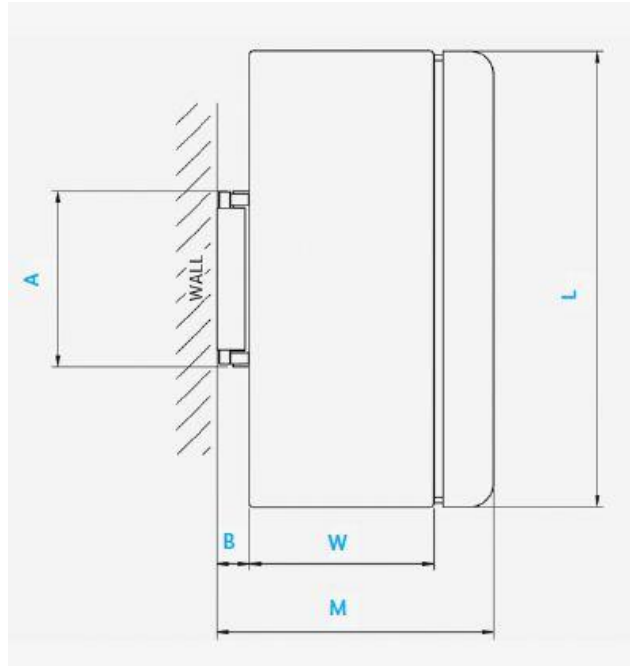

Code	3063	3067
Size	1	2
User Weight (kg)	150	150
Height Range (mm)	390-960	390-960
Table Dimensions		
L Length (mm)	1400	1800
W Width (mm)	650	650
M Width (mm)	1110	1110
Safety Side		
Y Height (mm)	165	165
Wall Frame		
A Width (mm)	700	700
B Depth (mm)	110	110
C Height (mm)	1150	1150
Misc		
S Width (mm)	300	300
Shipping Weight (kg)	80	85



4.0 FOR YOUR SAFETY



STOP!

Please read these instructions CAREFULLY and THOROUGHLY

- This product is suitable for installation and use in a wet room. Please follow installation instructions as described in Section 5 carefully and thoroughly.
- The user should **NOT** be left unattended whilst on the changing table. Always ensure a responsible therapist or carer is in attendance.
- The Hi-Riser Showering changing table height should **NEVER** be adjusted without a carer in attendance.
- Always ensure the safety side is in the 'up' position once a patient is on the table.
- When storing the product vertically (up position), check to ensure that the locking plunger pin is fully engaged.
- When not in use for periods of time, isolate the electrical supply.
- Always keep this product away from naked flames, cigarettes and sources of heat including open fireplaces, radiators and heaters.
- Regular maintenance checks and cleaning are essential for the safe use of this equipment (see care and maintenance section).
- **DO NOT** fit parts or accessories of other manufacturers to this product unless authorised to do so in writing by G&S Smirthwaite Ltd. Failure to follow these instructions will not only invalidate the guarantee but could make the product dangerous to use. G&S Smirthwaite Ltd will not accept liability for any injury or damage incurred through such malpractices. Any repairs required must be carried out by G&S Smirthwaite Ltd authorised personnel.
- If any part is loose, damaged or functioning incorrectly, **DO NOT** use until rectified.
- The Hi-Riser Showering changing table is CE marked. This certifies that it meets all relevant European safety requirements.
- If you believe the product or any fitted accessory to be faulty at any time, **DO NOT USE** – contact Smirthwaite by telephone on +44 (0)1626 835552



5.0 SURVEYING AND INSTALLATION

5.1 SURVEYING PROCEDURES

- Changing benches/tables are normally installed in small rooms with limited space. In such circumstances it is vitally important to take accurate measurements of the whole room in question, and make a plan to scale if possible.
- **Ensure that the intended wall for installation is strong enough to support the weight of the changing bench plus the patient.**
- If the wall is of brick or concrete construction, it will be strong enough to support the equipment without the need of the backing board.
- If the wall is of hollow or soft insulation block construction, then we would always recommend the backing board is used.
- It is possible to install the bench using wall and floor fixings; care must be taken to survey the junction between wall and floor. If this junction has a large radius fillet, it may be necessary to space the frame off the wall – any such adjustment will impact on the overall installation footprint so must be taken into account when assessing clearances.
- It is possible using the two leveling bolts to provide stability to the frame at the mating surface with the floor in instances where the customer does not wish to make installation holes in the flooring surface itself.
- Check for the position of dado rails, window sills, electrical power points, switches, etc which may affect the installation.
- Check there is sufficient room around other facilities, e.g. wash basins, toilets, etc.
- Remember to take into account the safety rail dimensions – check that the bench would be capable of adjustment over the height range without fouling.
- Check that doors would be clear and that access is still possible
- Inspect the wall to see if padding/spacing is required to correct wall imperfections
- The Hi-Riser Showering requires a 220-240V AC 50Hz or 110V AC 60Hz power supply. Electrical components are rated to IP66, which permits use in wet environments.



STOP!

If in any doubt, ALWAYS seek PROFESSIONAL ADVICE

5.2 INSTALLATION TOOLS REQUIRED

- Electric hand drill, with appropriate drill bits for wood and masonry
- Set of spanners
- Tape measure
- Spirit level
- Hammer
- Screw driver
- Personal Protection Equipment (PPE); gloves, safety glasses



5.3 INSTALLATION PROCEDURE

- Carefully unpack the Hi-Riser and lay all parts on to the floor
- Check all components are present and check for damage that may have occurred in transit (see illustration below):

Wall Frame

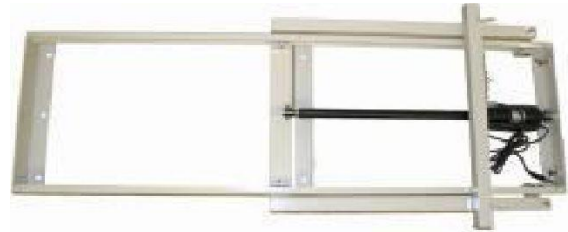

Bench frame with mattress and safety side



Wall Frame Cover



Handset



Transformer and plug



Fixing screw pack





STOP!

It is strongly recommended that two people carry out the installation due to the weight of the product

- Store the wall frame cover and backing board (if ordered) safely until required
- Offer up the wall frame into the desired position to mark and drill the holes for the fixings; adjust the two leveling bolts as required.
- Where a backing board is to be used, it should be drilled to take fixing screws (minimum 8) – check the screws do not interfere with the wall frame when mounted.
- Fit the fixing bolts and loosely fit the frame to the wall or backing board, being careful not to trap the electrical cable
- Before tightening fixings, check frame is vertical in all directions, and if necessary fit packing to achieve
- The bench frame can now be fixed to the wall frame; the two hinge bolts that are loosely fitted to the wall frame should be removed, and a small amount of Loctite applied to the first 5mm.
- Offer up the bench and insert the two bolts previously prepared but do not over-tighten. The bolts must not protrude more than approx 1mm.
- The bench should now be raised into the vertical position and locked in position
- Fit the support link arms using the screws, nuts and washers that have been loosely fitted. Do not over tighten; make sure the links can rotate freely.
- The two side trims may now be fitted using the plastic push fit retainers supplied
- Connect the electrical supply and test the bench by raising and lowering to each of the limits of travel to ensure there are no obstructions
- The 24V transformer can now be fixed to the wall in a suitable position, or on a bracket/shelf

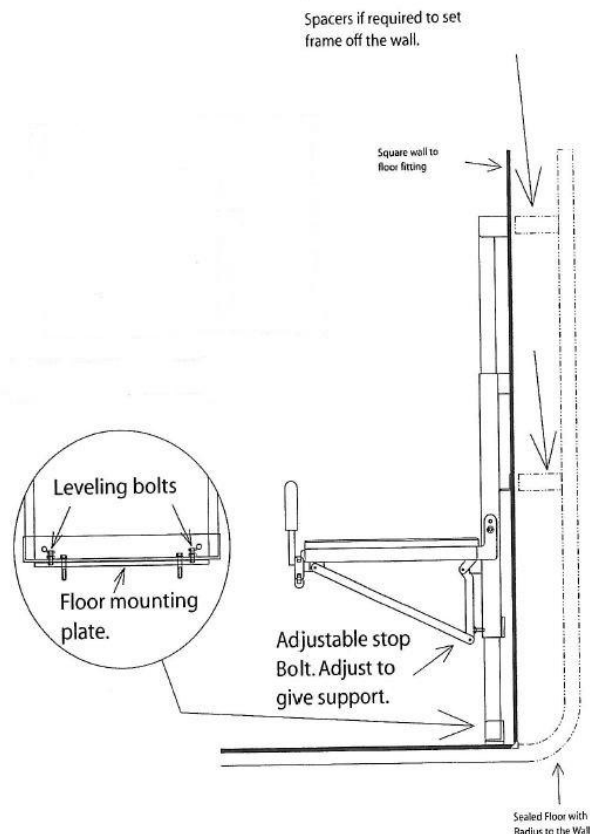

- Raise and lower the bench with a load to ensure it is working satisfactorily – do not repeat in rapid succession as this will put stress on the motor system and can cause damage through overheating.
- The main front cover can now be refitted and fixed into place by sliding it down behind the bench so that the Velcro holds the top firmly. Use the studs supplied to fix into place.
- Attach the drainage hose to the underside of the bed using the washer provided as a seal. The hose can be allowed to drain directly on to the floor in wet rooms, or can be placed in a suitable waste plumbing system – this waste plumbing system should be provided by a competent plumber.
- Place a copy of the user instructions on the wall near to the changing bench, where it can easily be read – ensure anyone that will be using the bench is trained and familiar with correct usage.

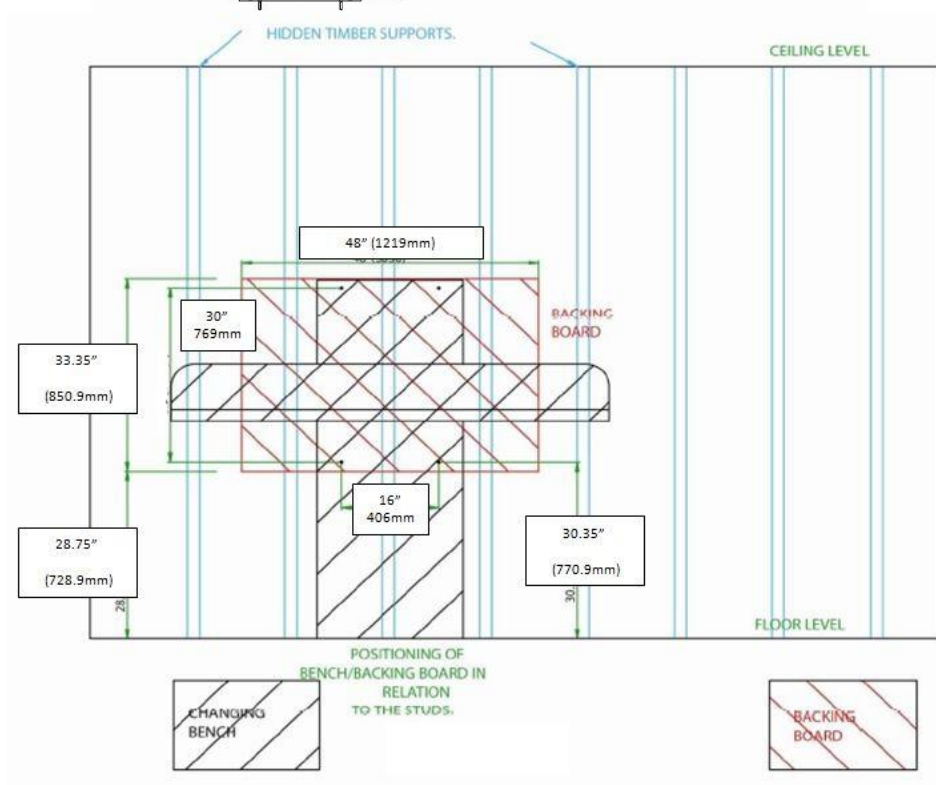
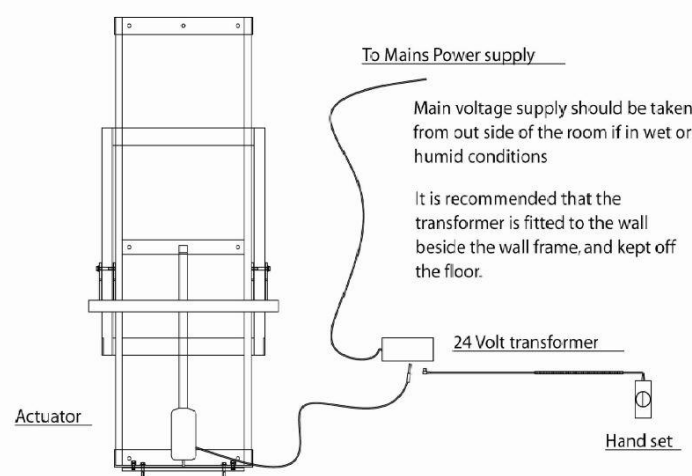

6.0 HOW TO USE YOUR HI-RISER SHOWERING CHANGING TABLE



IMPORTANT!

For non-hoist transfers always ensure the safety side is in the fully stowed position (down). When the user has been transferred onto the Hi-Riser Showering table, please ensure safety side is in the fully upright position.

- Ensure that the electrical supply to the changing table is ON

- The bed can be lowered from its stowed position by using one hand to gently press the mattress against the frame, and at the same time using your second hand to release the plunger locking pin which is situated by the right hand hinge (shown circled opposite).

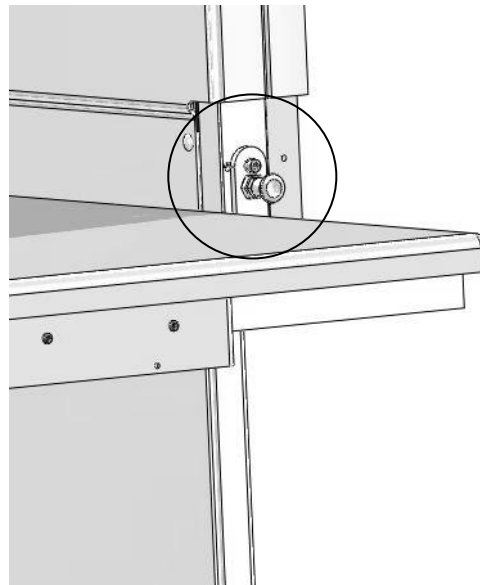

- When unlocked, use both hands to lower the bed into the horizontal position.

- Before transferring a patient, adjust the height of the bed by using the hand controller 'Up' and 'Down' buttons/arrows, as shown opposite.

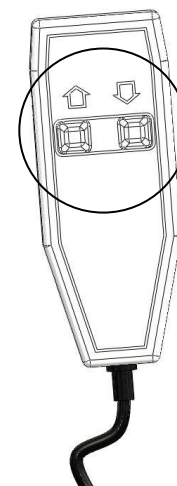

- With the patient safely transferred onto the bed, rotate the safety rail into the vertical position and allow it to drop into its retaining slot – check it is in place by gently pulling outwards (towards your body).

- The bench can now be raised to the optimum position, which will depend on the carer

- To dismount the patient, the process is the reverse of the steps described above



- Once the patient has been dismantled, ensure the bed mattress is wiped as per the cleaning instructions in Section Y.
- The bench can be stowed away by lifting it up with both hands, and when vertical press firmly to slightly compress the mattress – listen for a ‘click’ which indicates that the plunger locking pin has engaged into the locked position. Confirm this by gently pulling the bed toward you.

N.B. If using a hoist system for patient transfer, the patient can be lowered onto the bed when already set at the desired height, with the safety rail set to the vertical position.



7.0 CARE AND MAINTENANCE



IMPORTANT!

Cleaning is recommended on a regular basis

- To clean the bench use a damp soft cloth with mild soap
- Rinse with clean cloth and water
- DO NOT use solvents, abrasives, synthetic detergents and wax polishes
- ALWAYS wipe dry after use
- ALWAYS keep this product away from naked flames, cigarettes and sources of heat including open fireplaces, radiators and heaters
- For further information please refer to MHRA or Local Authority cleaning guidelines

7.1 MAINTENANCE CHECKS



IMPORTANT!

Regular maintenance checks are required

DAILY CHECKS

- Check the bench for signs of damage or wear and tear
- Keep the product clean
- Check the safety rail can be stowed and locked into the vertical position
- Check that the bed rises and lowers when activated by the handset
- Check that the bed can be securely stored in the vertical position, and that the plunger locking pin engages.

7.2 SERVICE INTERVAL

The Hi-Riser Showering changing table should be serviced every 1 year. Servicing must only be undertaken by a Smirthwaite service engineer, or by a Smirthwaite trained representative.



7.3 NOMINAL SERVICE LIFE

Your product has a nominal service life of 7 years, during which full post-sales support will be available with regard to spares and servicing.

Product service life has been determined based upon the design complexity of product, and the anticipated exposure to normal use.

Good practice dictates all Smirthwaite products have been designed and manufactured to high levels of safety and quality, and will meet requirements of normal use when maintained in line with our servicing recommendations.

	<p>STOP!</p> <p>If the product has been out of use for an extended period of time (6 months or more) it should always be serviced prior to being reissued.</p> <p>If the product has been subjected to ‘heavy’ or ‘constant’ use, the service should be reduced to half the recommended period.</p> <p>Constant and/or heavy use is considered to be:</p> <ul style="list-style-type: none">• Daily use above 7 hours duration• Weekly use above 5 days duration• Monthly use above 10 months per year• Use by a client who is at 90% to 100% of the maximum weight limit of the product. The maximum weight limit must NEVER be exceeded• Use by a client who is extremely active, either voluntarily or involuntarily
---	--

7.4 EXTENDING NOMINAL SERVICE LIFE

At Smirthwaite we are proud to produce products that have a reputation for quality and durability.

We believe our products have the potential to provide benefits to our clients beyond the nominal service life documented above.

We will continue to provide full support beyond the nominal service life provided the following conditions are met:

1. A full service schedule has been maintained.
2. A full service and inspection is undertaken at the end of the nominal service life period
3. The product is subsequently serviced annually (or biannually if under ‘heavy/constant’ use conditions)
4. Smirthwaite reserve the right to limit support where parts/components are no longer available



7.5 DOCUMENTATION/RECORDS

- It is the responsibility of the current equipment owner to ensure the 'Instructions for Use' manual and any further manuals for accessories fitted to the equipment are handed over to the new owner at the time of exchange/sale
- It is the responsibility of the current equipment owner to ensure the service and inspection record form is kept up to date

7.6 PRODUCT CONFIGURATION

- Smirthwaite will document and maintain a record of the original product configuration at the time of first sale
- Smirthwaite will not be held responsible for any subsequent changes to this configuration unless authorized to do so in writing by G&S Smirthwaite Ltd
- It is the equipment owner's responsibility to maintain their own records of changes to the equipment configuration and to be able to provide such records to subsequent owners to maintain traceability
- We recommend an inspection/service by a Smirthwaite Service Engineer (or Smirthwaite trained engineer) whenever a significant change is made to product configuration to ensure the product is safe to use. **If in any doubt, ALWAYS seek ADVICE**



IMPORTANT REMINDER!

DO NOT fit parts or accessories of other manufacturers to this product unless authorized to do so in writing by G&S Smirthwaite Ltd.

Any servicing or repairs required must be carried out by G&S Smirthwaite Ltd (or a Smirthwaite trained engineer).

If you believe this product to be faulty – DO NOT USE – Contact G&S Smirthwaite Ltd on T: +44 (0) 1626 835552

If in any doubt, ALWAYS seek ADVICE.



7.7 EUROPEAN DIRECTIVE 2002/96/EC - WASTE ELECTRICAL AND ELECTRONIC EQUIPMENT (WEEE)

The Waste Electrical and Electronic Equipment Directive (WEEE Directive) came into force in January 2007. The Directive aims to both reduce the amount of electrical and electronic equipment being produced and to encourage everyone to reuse, recycle and recover it.

As the responsible manufacturer, Smirthwaite operate a 'take back' scheme wherein we accept electrical and electronic components returned to our factory at the end of their product service life.

Please note, we are obligated only to accept the return of electronic/electrical components for responsible recycling, not complete products or assemblies.

Please contact G&S Smirthwaite Ltd on T: +44 (0) 1626 835552 should you require any further information.

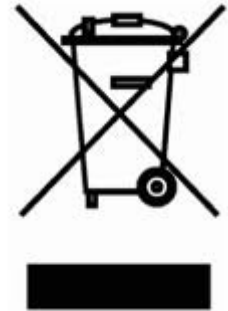

8.0 GUARANTEE & SERVICE

The product is issued with a full parts and labour guarantee for 2 years from the date of delivery. This guarantee does not apply to accidental damage caused through inappropriate use of the product. This guarantee is issued at the discretion of G & S Smirthwaite Ltd on RTB (Return to Base) basis. If you have any questions or doubts relating to the safety or use of the product please contact us for advice or assistance on:

T: +44 (0)1626 835552

E: enquiries@smirthwaite.co.uk



9.0 CONTINUOUS IMPROVEMENT

G & S Smirthwaite Ltd are committed to continuous improvement to their product range. Should you have any suggestions or comments please send them to our product design department at: enquiries@smirthwaite.co.uk

G&S Smirthwaite Ltd reserve the right to change the specification or material without prior notice.

For catalogues, help and further information on our products please contact us at:

G&S Smirthwaite Ltd
17 Wentworth Road
Heathfield
Devon
TQ12 6TL

T: +44 (0)1626 835552

F: +44 (0)1626 835428

E: enquiries@smirthwaite.co.uk

W: www.smirthwaite.co.uk



10.0 WARRANTY & AFTERSALE

10.1 Product Information

Model:	
Size:	
Date of Manufacture:	
Serial Number:	
Final Inspection	

10.2 Service & inspection record form:

Date	Procedure	Service Personnel



Notes





G & S Smirthwaite, 17 Wentworth Road, Heathfield, Newton Abbot, Devon.TQ12 6TL
T: +44 (0) 1626 835552 F: +44 (0) 1626 835428 E: enquiries@smirthwaite.co.uk
www.smirthwaite.co.uk

